

**THE DETERMINANTS AND VALUE
RELEVANCE OF RISK DISCLOSURE
IN THE INDONESIAN BANKING SECTOR**

DWI NITA ARYANI

A thesis submitted to the University of Gloucestershire
in accordance with the requirements of the degree of Doctor of Philosophy
in the Business School

February 2016

*I dedicate my thesis to
my beloved late husband, Achmad Harioseno,
and my lovely children Anindita, Anggito and Bagas*

I declare that the work in this thesis was carried out in accordance with the regulations of the University of Gloucestershire and is original except where indicated by specific reference in the text. No part of the thesis has been submitted as part of any other academic award. The thesis has not been presented to any other education institution in the United Kingdom or overseas.

Any views expressed in the thesis are those of the author and in no way represent those of the University.

Signed

Date: February 2016

ABSTRACT

The aim of the current study is to analyse the association between the determinants and the value relevance of risk disclosure in the Indonesian banking sector. The purpose will be derived into four research objective: to measure the extent of risk disclosure in the Indonesian banking sector; to compare the risk disclosure practice between listed and unlisted banks, and between Islamic and non-Islamic banks; to study the determinants of risk disclosure and what factors affect a bank's decision to disclose risk information; and to analyse the value relevance information on risk disclosure of listed banks, unlisted banks, Islamic banks, and non-Islamic banks.

Agency theory, signalling theory, stakeholder theory, and communication theory were used for underpinning theory. The annual reports of 120 banks which released between 2008 and 2012 were employed for testing in this research. Risk disclosure was measured by the number of Indonesian risk keywords divided by the number of Indonesian sentences in annual reports. Firm value for listed banks was measured by Tobin's Q. The Black Scholes Merton model was employed for measuring firm value of unlisted banks.

The number of risk keywords, number of sentences, and risk disclosure in the Indonesian banks showed an upward trend. The delta of size, liquidity, profitability, leverage, and earnings reinvestment did not have association with the delta of risk disclosure in all banks, LB IB, NIB. The delta of firm value in all banks, LB, ULB, and NIB has an association with aggregate the delta of firm characteristics and the delta of risk disclosure. Risk disclosure in annual reports was not value relevant for stakeholders.

This method will construct a new measurement of risk disclosure; and firm value for unlisted banks. The regulators, banks' managers and bank supervisory should pay more attention to increasing the usefulness of disclosure, the completeness of the risk information, and how to deliver signals and information more understandably and readably for stakeholders. This research adds to the limited literature relating to earnings reinvestment, new measurement of risk disclosure, and firm value for unlisted banks. The results enrich agency, signalling, stakeholder, communication and dividend theories.

Keywords: risk disclosure, value relevance, firm value, Black Scholes Merton Model

ACKNOWLEDGMENT

First of all, I am extremely thankful to Almighty Allah for giving me the strength and ability to complete my study.

I would like to thank with genuine gratitude and high appreciation to my best supervisors, Professor Bob Ryan and Professor Khaled Hussainey, who have given patient guidance and always gave brilliant ideas and advice; and constructive comments for improving my thesis.

The highest honours and thanks to my examiners, Dr. Tracy Jones and Dr. Alaa Mansoer Zalata, for their useful comments, suggestions, which considerably improved my thesis

I also sincerely thank the Head of Malangkecwara School of Economics, and its staff and colleagues who gave me permission to take this opportunity. I would not be here without their support and recommendation.

Special thanks to the Directorate General of Higher Education, Ministry of National Education, Republic of Indonesia for the financial support. It would not have been possible to finish my PhD in the UK without the scholarship.

I gratefully thank to the participants in SWAG Conference 2013 at the University of Gloucestershire; Post Graduate Research Conference at University of

Gloucestershire on 22nd -23rd of June 2015; and BAFA Conference at Bath University on September 4th, 2015 for their comments and suggestions.

Even though you could not be beside me forever, I am grateful to thank from the bottom of my heart my beloved late husband, Achmad Harioseno, for his sacrifice, enormous love, encouragement; my lovely daughter, Anindita Hapsari, who always cheered me up although I never accompanied her when she needed me; my beloved sons, Anggito Haryo Pradipta and Bagas Haryo Rukmono, who made me smile and feel happy during my busy time.

I would like to give my deep thanks to my mother (Sudewi), my late father (Sarodja), my sisters (Evi Artsini and Ambar Lukitaningsih) and brothers (Haryo Yudono and Heru Widyatmoko), who always gave affection, support, and their prayers; also to my sisters in law, Ani Andarmilah and Endang Susetyowati, who helped me in everything when I was away.

Special thanks to the academics and staff in the University of Gloucestershire, and my best friends: Amina, Aasim, Bruhant, Dorojatun Prihandono, Dandy Supriadi, Maryam, Nazahah, (late friend) Priyo Darmawan, Rosenia, Yan Huo, and Vivian for sharing, discussing, helping me from the beginning and finishing my study. I am thankful to the “Al Hijrah” family, mas Yopi, and mbak Anik, who kindly help, love and support; also thank to Imelda who gave me a room to stay in during my study.

TABLE OF CONTENTS

ABSTRACT.....	V
CHAPTER 1 INTRODUCTION.....	1
1.1 BACKGROUND.....	1
1.2 RESEARCH MOTIVATION.....	5
1.3 RESEARCH AIM:.....	8
1.4 RESEARCH OBJECTIVES.....	8
1.5 RESEARCH QUESTIONS AND RESEARCH HYPOTHESES.....	10
1.6 CONTRIBUTION TO KNOWLEDGE.....	14
1.7 EMPIRICAL RESULTS.....	15
1.8 OVERVIEW OF THE THESIS.....	17
CHAPTER 2 BANKING IN INDONESIA.....	24
2.1 INTRODUCTION.....	24
2.2 REGULATIONS RELATED TO DISCLOSURE.....	24
2.2.1 <i>The Bank of Indonesia's Regulations</i>	25
2.2.2 <i>The Indonesia Stock Exchange Regulations</i>	28
2.2.3 <i>Basel</i>	29
2.2.4 <i>International Financial Reporting Standard (IFRS)</i>	31
CHAPTER 3 THEORETICAL FRAMEWORKS.....	33
3.1 INTRODUCTION.....	33
3.2 STAKEHOLDER THEORY.....	34
3.2.1 <i>Definition of Stakeholder</i>	34
3.2.2 <i>The importance of stakeholder theory in this research</i>	35
3.2.3 <i>The importance of stakeholders for a company</i>	36
3.2.4 <i>Summary</i>	38
3.3 AGENCY THEORY.....	38
3.3.1 <i>The importance of agency theory related to the research</i>	39
3.3.2 <i>What is the Agency Theory?</i>	41
3.3.3 <i>The agency problem</i>	43
3.3.4 <i>Agency problem in banking</i>	44
3.3.5 <i>Agency cost</i>	47
3.3.6 <i>How to minimise agency problems</i>	49
3.3.7 <i>The relationship between agency theory and firm's performance</i>	50
3.3.8 <i>Summary</i>	51
3.4 COMMUNICATION THEORY.....	53
3.4.1 <i>The importance of communication theory related to the research</i>	53
3.4.2 <i>Communication process</i>	54
3.4.3 <i>Summary</i>	55

3.5	SIGNALLING THEORY	56
3.5.1	<i>The importance of signalling theory related to the research</i>	57
3.5.2	<i>How did it start</i>	58
3.5.3	<i>Relationship between Agency Theory and Information Asymmetry</i>	60
3.5.4	<i>The Importance of signalling theory for firms and investors</i>	62
3.5.5	<i>Signalling in different types of firms</i>	64
3.5.6	<i>Problem with signalling</i>	66
3.5.7	<i>Conclusion</i>	69
CHAPTER 4	LITERATURE REVIEW AND HYPOTHESES DEVELOPMENT	72
4.1	INTRODUCTION	72
4.2	RISK DISCLOSURE	72
4.2.1	<i>What is disclosure?</i>	72
4.2.2	<i>What is Risk?</i>	73
4.2.3	<i>What is Risk Disclosure?</i>	74
4.2.4	<i>Types of disclosure</i>	75
4.2.5	<i>The quality of disclosure</i>	77
4.2.6	<i>The consequences of risk disclosure</i>	78
4.3	THE DETERMINANTS OF RISK DISCLOSURE AND HYPOTHESES DEVELOPMENT.....	83
4.4	VALUE RELEVANCE	96
4.5	THE DIFFERENCES BETWEEN LISTED AND UNLISTED BANKS	102
4.5.1	<i>The benefit of listed companies</i>	104
4.5.2	<i>The hindrances of listed and unlisted companies</i>	105
4.6	THE DIFFERENCES BETWEEN ISLAMIC AND NON-ISLAMIC BANKS.....	107
4.6.1	<i>Shariah rules in transactions</i>	107
4.6.2	<i>Contracts in Islamic banks</i>	110
4.6.3	<i>The Basic Law of Sharia Capital Market</i>	114
4.6.4	<i>The comparison between Islamic and non-Islamic banks</i>	116
CHAPTER 5	RESEARCH METHODOLOGY	124
5.1	INTRODUCTION	124
5.2	RESEARCH METHODOLOGY.....	124
5.3	RESEARCH METHODS	129
5.4	THE POPULATION AND DATA PERIODS COVERED.....	131
5.5	DEPENDENT AND INDEPENDENT VARIABLES.....	132
5.5.1	<i>Dependent variables</i>	132
5.5.2	<i>Independent variables</i>	156
5.6	VALIDITY AND RELIABILITY TEST	164
5.7	SUMMARY.....	167
CHAPTER 6	EMPIRICAL RESULTS AND ANALYSIS	170
6.1	INTRODUCTION	170
6.2	THE RESEARCH POPULATION.....	170

6.3	CLASSIC ASSUMPTION TESTS	172
6.4	THE RESULTS OF RQ1: HOW CAN THE EXTENT OF RISK DISCLOSURE IN THE INDONESIAN BANKING SECTOR BE EFFECTIVELY QUANTIFIED?	173
6.5	THE RESULTS OF RQ 2: ARE THERE DIFFERENCES BETWEEN THE EXTENT OF RISK DISCLOSURE PRACTICE BETWEEN LISTED BANKS AND UNLISTED BANKS, AND BETWEEN ISLAMIC BANKS AND NON-ISLAMIC BANKS?	186
6.5.1	<i>The Differences between Listed and Unlisted Banks</i>	186
6.5.2	<i>The differences between Islamic banks and non-Islamic banks</i>	194
6.6	THE RESULTS OF RQ 3: WHAT FACTORS AFFECT A BANK'S DECISION TO DISCLOSE RISK?200	
6.6.1	<i>RQ 3.1: The factors affecting banks' decisions to disclose risk in all banks</i>	201
6.6.2	<i>RQ 3.2: The factors affecting banks' decisions to disclose risks in listed banks</i> ..	210
6.6.3	<i>RQ 3.3: The factors affecting banks' decisions to disclose risks - unlisted banks</i>	217
6.6.4	<i>RQ 3.4 The factors affecting a bank's decision to disclose risk in Islamic banks</i>	223
6.6.5	<i>RQ 3.5 The factors affecting banks' decision to disclose risk in non-Islamic banks</i>	228
6.7	THE RESULTS OF RQ4 - THE VALUE RELEVANCE OF RISK DISCLOSURE	234
6.7.1	<i>RQ 4.1: The value relevance of risk disclosure in all banks</i>	235
6.7.2	<i>RQ 4.2 The value relevance of risk disclosure in listed banks</i>	245
6.7.3	<i>RQ 4.3 The value relevance of risk disclosure in unlisted banks</i>	253
6.7.4	<i>RQ 4.4 The value relevance of risk disclosure in Islamic banks</i>	261
6.7.5	<i>RQ.4.5 The value relevance of risk disclosure in non-Islamic banks</i>	267
6.8	SUMMARY.....	278
CHAPTER 7 CONCLUSION		279
7.1	CONCLUSION.....	279
7.2	THEORETICAL IMPLICATIONS	289
7.3	PRACTICAL IMPLICATIONS	291
7.4	LIMITATIONS.....	293
7.5	SUGGESTIONS FOR FUTURE RESEARCH.....	295
REFERENCES		297
APPENDIX A - PREVIOUS RESEARCH		311
APPENDIX B - VALIDITY AND RELIABILITY RISK KEYWORDS		316
APPENDIX C - THE BANKS AND THE DATA OF EACH VARIABLE		319
APPENDIX D - FREE OF HETEROCEDASTICITY		330
APPENDIX E - THE BANKS WERE EXCLUDED		336
APPENDIX F - NORMALITY TEST FOR ISLAMIC BANKS VARIABLES		342
APPENDIX G – RESULTS OF LAGGED		343
APPENDIX H – THE RESULTS OF VALUE RELEVANT		344
APPENDIX I – THE RESULTS OF SPSS		349

LIST OF TABLES

Table 4.1 Research Hypotheses and Predicted Signs.....	101
Table 4.2 The advantages and weaknesses of listed companies.....	106
Table 4.3 The differences between listed and unlisted companies	107
Table 4.4 Summary of the differences between Islamic banks and non-Islamic banks	120
Table 4.5 Summary of Listed banks, Unlisted banks, Islamic banks and Non-Islamic banks	121
Table 5.1 The valuation variable.....	144
Table 5.2 Volatility estimator	146
Table 5.3 The Merton structural debt model	147
Table 5.4 Black Scholes option pricing model for estimating value of equity	152
Table 5.5 Daily share price.....	154
Table 5.6 Relatives	154
Table 5.7 The correlation.....	155
Table 6.1 Total banks in Indonesia over the period 2008 to 2012.....	171
Table 6.2 Summary of tolerance and VIF for the correlation with risk disclosure	173
Table 6.3 Summary of tolerance and VIF for the correlation with firm value	173
Table 6.4 The average number of Indonesian risk keywords in all annual reports	174
Table 6.5 The lowest and the highest number of risk keywords	175
Table 6.6 The average number of Indonesian sentences in any annual reports	178
Table 6.7 The lowest and the highest number of Indonesian sentences in all annual reports	179
Table 6.8 The average of risk disclosure in any annual reports	181
Table 6.9 The lowest and the highest number of risk disclosure in each year	185
Table 6.10 Listed and Unlisted Banks Group Statistics.....	187
Table 6.11: Listed and Unlisted Banks - Independent Test.....	194
Table 6.12 Islamic and Non-Islamic banks - Group Statistics	197
Table 6.13 Islamic and Non-Islamic banks - Independent Test Samples.....	199
Table 6.14 Pearson's correlation between firm characteristics and risk disclosure and firm value in all banks	203
Table 6.15 Summary of the Result of OLS Regression Risk Disclosure in all banks.....	204
Table 6.16 The Pearson's Correlation of listed banks	212
Table 6.17 Summary of Regression Risk Disclosure in Listed Banks	213
Table 6.18 The Pearson Correlation of unlisted banks	219
Table 6.19 Summary of the Result of Regression Risk Disclosure in unlisted banks	220
Table 6.20 The Pearson's correlation of firm characteristics, risk disclosure and firm value in Islamic banks	226
Table 6.21 Summary of the Result of OLS Regression Risk Disclosure in Islamic banks	227
Table 6.22 The Pearson's correlation between the delta of firm characteristics, the delta of risk disclosure and the delta of firm value in non-Islamic banks	232
Table 6.23 Summary of the Result of OLS Regression Risk Disclosure in non-Islamic banks	233
Table 6.24 The Pearson correlation between firm characteristics, risk disclosure and firm value.....	240
Table 6.25. Summary of the Result of OLS Regression Firm Value in All Banks	240
Table 6.26 The Summary of Value Relevance.....	241
Table 6.27 The Pearson's Correlation of listed banks	251
Table 6.28 Summary of the Result of Multiple Regression for Firm Value in Listed banks	251

Table 6.29 The Pearson correlation between the delta of firm characteristics, the delta of risk disclosure and the delta of firm value in unlisted banks.....	258
Table 6.30 Summary of the Result of Regression Firm Value in Unlisted Banks	259
Table 6.31 The Pearson’s correlation between firm characteristics, risk disclosure and firm value of Islamic banks.....	262
Table 6.32 Summary of the Result of OLS Regression Firm Value in Islamic banks	263
Table 6.33 The Pearson correlation between the delta of firm characteristics, the delta of risk disclosure and the delta of firm value non-Islamic banks.....	270
Table 6.34 Summary of Regression between the delta of risk disclosure, the delta of firm characteristics and the delta of firm value	270
Table 6.35 The resume of hypotheses.....	277

LIST OF FIGURES

Figure 3-1 The stakeholder of the corporation.....	37
Figure 3-2 Schematic diagram of a general communication system	54
Figure 3-3 The process of signals and noises	71
Figure 4-1 Dividend growth for two earnings reinvestment policies.....	92
Figure 4-2 Islamic banks’ sources of funds and allocation of funds.....	113
Figure 4-3 The business of banking.....	123
Figure 5-1 The relationship between share price and fair value.....	143
Figure 5-2 The relationship between value of firm and value of assets	144
Figure 6-1 The average number of total risk keywords.....	176
Figure 6.2 The average number of Indonesian sentences in any annual reports	178
Figure 6.3 The number of risk disclosure in all annual reports in each year	182

CHAPTER 1

INTRODUCTION

1.1 Background

A number of major failures of risk assessment contributed to the financial crises in 1997 and 2008, and the Financial Stability Forum (2008) suggested that these crises happened since banks miscalculated their risks. In addition, the financial crisis was also caused by a lack of transparency in the financial reports (Acharya, Richardson, Philippon, & Roubini, 2009, p. 73). Based on previous financial crisis experiences, a growing demand for better reporting of business risks has emerged in recent decades. This has influenced a range of businesses, banks in particular, to improve their risk reporting (ICAEW, 2011, p. iii). Furthermore, Ryan, Scapen, and Theobald (2002) asserted that research in the corporate disclosure area has developed and has become essential, and within this it is accepted that disclosure comprises mandatory and voluntary disclosure.

Stakeholders, investors notably, as users of annual reports need company risk information in order to measure and minimise the risks before they make financial decisions. Nevertheless, due to incomplete, scrappy and mutual exclusiveness of information in financial reports, users cannot easily interpret risk disclosure (Papa & Peters, 2011). The accounting literature also demonstrates that there is a significant risk information gap between firms and their stakeholders. Linsley and Shrives (2006) examined risk disclosure in the U.K. and stated that firms reported that quantitative risk information and risk narratives were lacking in coherence. These arguments indicated a gap in risk information; consequently, stakeholders are not able to accurately assess a firm's risk profile. Therefore, in order to help stakeholders to easily read firm performance

and to make good decisions, and to make financial reports more valuable for users, companies have to report more detailed information and understand what users need.

In the emerging capital markets and banking sectors, investors need transparency and accountability from a firm's annual report. The disclosure within the annual report has value relevance if companies give signals and report their performance more transparently and usefully for investors; hence, investors can use the annual report for consideration when they make financial decisions.

This research is focused in the banking sector because first, banks play a crucial role in the business and economics of the country. Second, banking is an industry which is highly confronted by risk. Third, it is an industry based on trust; therefore, banking is a highly regulated industry. Along with that, stakeholders such as depositors, investors and business partners will lose trust if a bank gives a bad impression. Finally, it should be the main concern of banks to maintain the loyalty of customers and shareholders; hence transparency and disclosure are important ingredients of banking sector stability. Therefore, the disclosure of banks needs to be studied independently from other industries (Linsley & Shrives, 2006).

Since banks deal with risks, they have an obligation to measure and manage the risks associated with their business activities and risk exposure, and provide financial reports for their stakeholders. Banks are required to submit financial statements and supplementary management reports to the public and also banks must adhere to some regulations in the delivery of information such as financial statements, referring to IFRS (International Financial Reporting Standards), Basel II (pillar 3), and other regulations

such as reports for the Capital Market Agency, or supervisory banks such a national central banks.

Agency theory asserted that the manager (agent) has access to internal information more than stakeholders (principals). The manager has an obligation to send a company's performance signals to the stakeholders, albeit that occasionally the information is misaligned with its actual condition. This condition induces asymmetric information. The existence of information asymmetry leads to the possibility of conflict between the principals and the agents. Companies that are transparent in reporting their performance are able to minimise agency conflict. Signalling theory also mentions that disclosing their condition and sending good signals to shareholders helps a firm increase its value.

Previous researches have exhibited either the factors affecting a firm's decision to disclose their performance or the association between firm characteristics and disclosure, nevertheless the results were unclear and inconclusive. The directions might be negative or positive, and the relationship could be significant or insignificant.

Elzahar and Hussainey (2012) and Linsley and Shrives (2006) demonstrated a positive relationship between risk disclosure and firm size. Conversely, Aljifri and Hussainey (2007) found a negative association between the level of disclosure and firm size.

Elshandidy, Fraser, and Hussainey (2011) revealed that firms with a high liquidity ratio transmit signals to the market participants. Marshall and Weetman (2007) found a significant relationship between disclosure and liquidity in UK firms. Nevertheless, Elzahar and Hussainey (2012) mentioned that there is an insignificant association between liquidity and risk disclosure.

Elzahar and Hussainey (2012) explained an insignificant relationship between profitability and the level of disclosure in an interim report, meanwhile, Barako, Hancock, and Izan (2007) found a negative association between profitability and level of disclosure. On the other hand, Ibrahim (2011) asserted that profitability and disclosure have a positive relationship.

A significant association between the leverage and the depth of information disclosure level was found by (Naser, Al-Khatib, & Karbhari, 2002). Conversely, Elzahar and Hussainey (2012) found leverage to be an insignificant determinant of narrative risk disclosure in interim reports.

An examination of the association between risk disclosure and earnings reinvestment is rarely done. Bank (2004) mentioned that earnings reinvestment is earnings that will not be paid as dividends to the shareholders, but will be reinvested in the main business to support a company's growth opportunities. Moreover, with bank capital formation through retention is necessary to support new lending. Baker and Powell (2012), who surveyed the Indonesia Stock Exchange companies, mentioned that management pays more attention to dividend policy because it can affect firm value and shareholder wealth. The company which has a reinvestment policy should disclose more in order to make sure the investors, by reinvesting the earnings, will give them higher earnings in the future. Beside mandatory disclosure, companies should report their performance voluntarily which is carried out by the company without regulatory stipulation. Voluntary disclosure of the annual reports is value-relevant for users and impacts firm value (Uyar & Kiliç, 2012). This is also supported by Al-Akra and Ali (2012) who highlight that voluntary disclosure has a positive association with firm value; however, it also seems

that firm value can be affected by many factors, and various studies have exhibited different results. Al-Akra and Ali (2012) found that liquidity and firm value do not have a relationship. Furthermore, Hassan, Romilly, Giorgioni, and Power (2009) reported that asset size and profitability are significant with mandatory disclosure but have a negative association with firm value, and that voluntary disclosure has a positive, but insignificant relationship with firm value. Meanwhile, leverage has an insignificant correlation with firm value.

This study seeks to fill the gaps in the literature of these contradictory results, by examining the factors affecting a bank's decision to disclose risk in its annual report, and distinguishes between listed, unlisted, Islamic, and non-Islamic banks in Indonesia.

1.2 Research Motivation

The motivation for choosing the banking sector as the population of this study has been explained above. This study is focused on examining banks in Indonesia for several reasons. First of all, Indonesia has a large total of banks, i.e 120 banks. Second, Indonesia is a developing country, and has an emerging capital market that has good potential economic growth, but deals with political and economic risk. The emerging capital market could be described as having a high share price volatility and promises to give high returns, but also represents high risks. Since banking itself is a high risk sector, more detailed company information is needed by investors in order to consider, measure and minimise risks before making financial decisions. Therefore, it is necessary to examine the extent of risk disclosure and the factors affecting Indonesian listed banks' decision to disclose risk.

Third, a survey by Pricewaterhouse Coopers (2000) showed that Indonesia scored very low in the area of perception standards of disclosure and transparency in the material information, being the lowest among Asian markets. It is interesting to examine whether the extent of risk disclosure after their survey in 2000 shows an upward or downward trend. Fourth, according to Kurniawan and Indriantoro (2000), in 1997 Indonesia experienced a banking crisis and also felt the impact of the global crisis in 2008. The factors that influenced and exacerbated the economic catastrophe in Indonesia were the weaknesses of risk management practices and corporate governance. This suggests that Indonesia still lacks transparency and disclosure.

Based on those experiences, investors should become more prudent in investing their funds. However, if investors were easily able to predict risks through reading firms' annual reports, risk disclosure would be perceived as valuable information to give to stakeholders. Along with that, studying the value relevance of risk disclosure in the Indonesian banks' annual reports will be crucial area to examine.

In addition, this research has uniqueness, this research will explain the extent of transparency in the banking sector in order to show how the trend of risk disclosure changed in Indonesia in the period 2008 to 2012. Moreover, this is the first study to measure the extent of risk disclosure by counting Indonesian risk keyword in annual reports.

The seventh reason is that the development of the Islamic banking system in Indonesia is still in emerging growth, which began in 1990 and has been carried out within the framework of the dual-banking system, i.e. Islamic banks and Non-Islamic banks with

Islamic banking windows (Sharia Business Unit of Conventional Bank). Islamic banks have particular characteristics, for example, they do not charge or pay interest, but instead employ profit and loss sharing, and have to comply with Sharia law. The Islamic banking system operates to provide an alternative banking system of mutual benefit to the community and banks, as well as accentuate aspect of fairness in trade, ethical investment, and avoiding speculative activities in financial transactions. For those reasons, it is important for banks based on Shariah law to obey all of the laws, regulations and guidelines. It is also important to ensure transparency in disclosing information properly. Regulations, legal principles and guidelines are different between Islamic banks and non-Islamic banks and there are also many differences in risk. In addition, Hussain and Al-Ajmi (2012) concluded that Islamic banks in Bahrain had a higher level on risk, liquidity, operational, residual and settlement risk than non-Islamic banks. There has been no previous study in Indonesia that has investigated the differences between risk disclosure in Islamic and non-Islamic banks, and the factors affecting Islamic banks' decision to disclose risk.

Brounen, Hans Op 't, and Raitio (2007) examined non-listed companies in the European market, and their result showed that the unlisted firms had many drawbacks such as an absence of transparency, limited size and tradability and complicated structures. The description of information that is conveyed in the annual report by listed and unlisted firms suggests that there may be differences between listed and unlisted Indonesian banks and between Islamic banks and non-Islamic banks; moreover, it will be pertinent to investigate the extent of voluntary disclosure in these groups. This research is interesting

because it will explore the differences between the extent of risk disclosure in listed and unlisted banks.

Previous studies have claimed a relationship between a firm's characteristics and the inconsistency of its voluntary and mandatory disclosure, which provides an opportunity now to examine the determinants of risk disclosure in annual reports and what the value relevance of risk disclosure is. There is no existing study that examines the value relevance of risk disclosure and the determinants of banks' risk disclosure in Indonesia, particularly among unlisted banks and Islamic banks. Moreover, in this study, the extent of risk disclosure is measured by Indonesian risk keywords as a proportion of total sentences in annual reports, with the purpose of adding to the literature related to disclosure in unlisted banks and Islamic banks.

Very little previous research has focused on unlisted firm value. Sachs, Ruhli, and Kern (2009); Wang, Ali, and Al-Akra (2013) mentioned that most studies in the field of firm value related to disclosure have tended to focus on listed companies rather than unlisted companies. Interestingly, this study provided additional evidence in examining firm value for unlisted banks by using a new method, namely the Black Scholes Merton model.

1.3 Research Aim:

The aim of the current study is to analyse the association between the determinants and the value relevance of risk disclosure in the Indonesian banking sector.

1.4 Research Objectives

Based on the research aim, the main purpose of this study is divided into four research objectives (RO) as follow:

a. To measure the extent of risk disclosure in the Indonesian banking sector.

By knowing the extent of risk disclosure in the Indonesian banking sector, this research will be able to demonstrate whether annual reports delivered by banks in Indonesia have described risk disclosure transparently.

b. To compare the risk disclosure practice between listed and unlisted banks, and between Islamic and non-Islamic banks.

Banks are mandated to provide their performance through annual reports to the central bank (the Bank of Indonesia). Since the listed banks trade in the stock exchange market, they have to adhere to capital market regulations to provide annual reports in order to reveal their performance. Listed companies have more stakeholders than unlisted banks, and the transparency of annual reports can be used to attract investors in order to obtain external funds. It suggests that listed banks are more likely to be transparent than unlisted banks.

Islamic banks in Indonesia just established in 1990, and deal with risks that are different from non-Islamic banks; furthermore, they must obey Islamic law thereby Islamic banks suppose more disclosure in reporting their performance than non-Islamic banks.

c. To study the determinants of risk disclosure and what factors affect a bank's decision to disclose risk information.

Previous research has shown that some factors have an association with risk disclosure, but the results have been different and sometimes contradictory. Related to risk, banks should disclose more and be transparent in their financial reports, because users really

need the firm performance information. Therefore, it is salient to know what factors affect banks' decision to convey risk disclosure.

d. To analyse the value relevance information on risk disclosure of listed banks, unlisted banks, Islamic banks, and non-Islamic banks.

The information in the annual reports is value relevant if it useful for investors and it can increase firm value. This research will explore whether the risk disclosure in the annual reports submitted by listed, unlisted, Islamic and non-Islamic banks is value relevant for users, and whether it provides benefits for stakeholders that are reflected in increased firm value.

1.5 Research Questions and Research Hypotheses

Following the research aim and objectives, this research has four specific research questions to be answered.

To achieve the first Research Objective (RO), namely to measure the extent of risk disclosure in the Indonesian banking sector, the following first research question is formulated as:

RQ1: How can the extent of risk disclosure in the Indonesian banking sector be effectively quantified?

In order to answer the above Research Question, the extent of risk disclosure is measured by counting the number of Indonesian risk keywords employed in the report and dividing that by the number of Indonesian sentences in the annual report, a task aided by software called QSR Nudist 6.

To achieve the second RO, namely to compare the risk disclosure practice between listed banks and unlisted banks, Islamic banks and non-Islamic Banks, the following second RQ is formulated as:

RQ 2: Are there differences between the extent of risk disclosure practice between listed banks and unlisted banks, and between Islamic banks and non-Islamic banks?

In order to answer the above RQ, Levene's test was conducted to examine the differences of the extent of risk disclosure between listed and unlisted banks, and between Islamic and non-Islamic banks, using SPSS software.

To achieve the third RO, namely to study determinants of risk disclosure and what factors affect a bank's decision to disclose risk information, the RQ is formulated as:

RQ 3: What factors affect a bank's decision to disclose risk?

In order to answer the RQ above, the determinants of risk disclosure, namely: firm size, liquidity, profitability, leverage, and earnings reinvestment will be extracted from the banks' annual reports and the correlation will be tested by Partial and Multiple Least Square and aided by SPSS.

The association between the delta of firm characteristics (firm size, liquidity, profitability, leverage, and earnings reinvestment) and the delta of risk disclosure as empirical Model 1 is formulated based on agency and signalling theories, and the results of previous studies. The following hypotheses represent the concerns of these theories, as follow:

First hypothesis (H1): There is a positive association between the delta of risk disclosure and the delta of firm size.

Second hypothesis (H2): There is a positive association between the delta of risk disclosure and the delta of liquidity.

Third hypothesis (H3): There is a positive association between the delta of risk disclosure and the delta of profitability.

Fourth hypothesis (H4): There is a positive association between the delta of risk disclosure and the delta of leverage.

Fifth hypothesis (H5): There is a positive association between the delta of risk disclosure and the delta of earnings reinvestment.

Sixth hypothesis (H6): There is an association between the delta of risk disclosure and the delta of firm characteristics.

To achieve the fourth RO, namely to analyse the value relevance of information on risk disclosure of listed banks, unlisted banks, Islamic banks, and non-Islamic banks, the RQ is formulated as:

RQ 4: What is the value relevance of risk disclosure in listed banks, unlisted banks, Islamic banks and non-Islamic banks?

In order to answer the above RQ, the value relevance is measured by the coefficient of correlation between risk disclosure and firm value.

Value relevance is the ability of a firm to send signals and detailed firm information that is useful for stakeholders and enables firm value to increase. Meanwhile, the association between the delta of firm characteristics and the delta of risk disclosure and the delta of

firm value which is formulated in the empirical Model 2 is derived from agency, signalling theories and reviewed from previous literatures. The hypotheses relates with this RQ as follow:

Seventh hypothesis (H7): There is a positive association between the delta of firm size and the delta of firm value.

Eighth hypothesis (H8): There is a positive association between the delta of liquidity and the delta of firm value.

Ninth hypothesis (H9): There is a positive association between the delta of profitability and the delta of firm value.

Tenth hypothesis (H10): There is a negative association between the delta of leverage and the delta of firm value.

Eleventh hypothesis (H11): There is a positive association between the delta of earnings reinvestment and the delta of firm value.

Twelfth hypothesis (H12): There is a positive association between the delta of risk disclosure and the delta of firm value.

Thirteenth hypothesis (H13): There is an association between the delta of firm characteristics and the delta of risk disclosure and the delta of firm value.

Fourteenth hypothesis (H14): Risk disclosure is value relevant for stakeholders.

1.6 Contribution to knowledge

Recent developments in disclosure have heightened public awareness of the need for transparency in annual reports. Disclosure in the Indonesian banking sector deserves special attention and needs a lot of improvement. The findings from this study are expected to make several important contributions in areas outlined below:

First, this study makes a major contribution to the literature of methodology and empirical contribution in measuring firm value for unlisted banks, including Islamic banks, because this is the first research that has measured firm value by employing the Black Scholes Merton Model.

Second, this research makes an original contribution to the literature of risk disclosure by exploring a new method to measure the extent of risk disclosure through banks' annual reports by counting Indonesian risk keywords.

Third, the findings should represent an exciting opportunity to advance the knowledge on earnings reinvestment and dividend theory, whereby previous studies have focused on investigating dividends.

Fourth, there is no previous research has tested the determinant of risk disclosure and compare it between listed and unlisted bank, Islamic and non-Islamic banks, hence this study enriches the literature of disclosure.

Fifth, the results of this study also enrich the literature related to agency, signalling, stakeholder, and communication theories.

1.7 Empirical results

The extent of risk disclosure in the Indonesia banking sector between the years 2008 and 2012 showed an upward trend. The average number of Indonesia risk keywords increased for all banks and each sector, whereby listed banks had number of risk keyword higher than unlisted banks and non-Islamic banks were always higher than Islamic banks. The number of total Indonesian sentences in the annual reports also exhibited an increased trend, whereby listed banks were greater than unlisted banks; meanwhile non-Islamic banks were higher than Islamic banks. The average level of risk disclosure demonstrated in the reports went up, whereby unlisted banks had a higher average than listed banks meanwhile non-Islamic banks have a bigger average than Islamic banks.

Even though the mean of the delta of risk disclosure in unlisted banks was higher than listed banks, Levene's test denoted that risk disclosure in the listed and unlisted banks was the same. The mean of the delta of risk disclosure among Islamic banks was higher than non-Islamic banks nevertheless; however, based on Levene's test the result showed there was no difference between them.

The H1 to H5, which suggested the delta of individual firm characteristic has a positive correlation with the delta of risk disclosure for all banks and each sector were rejected, except H4 and H6 in the unlisted banks, and H2 in non-Islamic banks. These results will be clearly described in the empirical results chapter. The multiple regression results demonstrated that the delta of firm characteristics, namely: firm size (assets), liquidity (LDR), profitability (ROE), leverage, and earnings reinvestment did not affect banks to reveal their risk more transparently in all banks, listed, Islamic, and non-Islamic banks'

annual reports. Model 1 of this study was not a fit model for examining the relationship between firm characteristics and risk disclosure.

The positive association between the delta of assets and the delta of firm value, as suggested in H7, was accepted for unlisted banks and Islamic banks. The H8 which suggested a positive association between the delta of liquidity and the delta of firm value was rejected for all banks and each sector. The positive association between the delta of profitability and the delta of firm value as suggested in H9 was accepted for all banks, listed and non-Islamic banks. The H10, which suggested a negative association between the delta of leverage and the delta of firm value was rejected for all banks and each sector. The positive association between the delta of earnings reinvestment and the delta of firm value as mentioned in H11 was rejected for all banks and each sector. The H12 which suggested there was a positive association between the delta of risk disclosure and the delta of firm value was rejected for all banks and each sector. The results of H7 to H12 are explained in more detail in the empirical results chapter.

The delta of firm value of all banks, listed, unlisted, and non-Islamic banks was found to be determined by the delta of firm characteristics and the delta of risk disclosure when those variables were aggregated as independent variables. Therefore, Model 2 was a fit model for testing the effect of the delta of firm characteristics and the delta of risk disclosure to the delta of firm value for all banks, listed, unlisted and non-Islamic banks. Therefore, H13 that supposed there was an association between the delta of firm characteristics and the delta of risk disclosure and the delta of firm value was accepted. The adjusted R square of all banks, listed, unlisted, Islamic and non-Islamic banks were 0.709; 0.783; 0.218; 0.267; and 0.738 respectively.

The results show risk disclosure did not have an association with firm value in all banks and each sector. These results showed that risk disclosure was not value relevant for users and could not push firm value. Therefore, H14 that supposed risk disclosure to be value relevant for stakeholders was rejected.

1.8 Overview of the thesis

The overall structure of the thesis takes the form of seven chapters, including this introductory chapter which describes an outline of each chapter. The history of banking in Indonesia and several regulations concerning disclosure for banking are described in chapter two. The theoretical framework comprising the stakeholder theory, agency theory, communication theory, signalling theory, will be written comprehensively in chapter three. The literature review about risk disclosure, and hypotheses development are explained in chapter four. The fifth chapter is concerned with research methodology and the methods used for this study. The empirical analysis describes research finding comprising the descriptive analysis, correlation analysis, accepting /rejecting hypotheses and the discussion of the research findings and answer to the research questions are presented in chapter six. Finally, the last chapter describes a critique of the key findings, the conclusion, tying up the various theoretical and practical implications of the findings, limitation of this research, and suggestions for future research. The over view of each chapter is described below.

Chapter 1: Introduction

Chapter one briefly explains the overall content of the thesis. It highlights the background of the importance of risk disclosure, the gap between determinants of risk disclosure in

previous research, and the development of risk disclosure in the Indonesian banking sector. This chapter also explains the motivation for undertaking this study focusing on Indonesian banking and contribution to knowledge. Moreover, this chapter states the research aim, objectives, questions, and hypotheses.

Chapter 2: Banking in Indonesia

Due to using Indonesian banking as the object of the research, chapter two explains several regulations regarding to disclosure in the annual report for banking in Indonesia, and other international regulations such as Basel and IFRS which are also concern in disclosure.

Chapter 3: Theoretical Frameworks

This chapter describes theories which have a relationship with developing the hypotheses and interpreting the findings. The theories for underpinning this study comprise Stakeholder, Agency, Communication, and Signalling theories.

Chapter 4: Literature Review and Hypotheses Development

This chapter describes a literature review which will criticise prior studies, identify gaps between the previous results and how this thesis will fills some of the gaps. In this chapter, the hypotheses will be developed based on the gap between theories and literature review. The second part explains risk disclosure, type and quality of disclosure and the consequences of disclosure. The third part describes the determinants of risk disclosure in details about the variables of firm characteristics that have association with risk disclosure and describe the relationship between the determinants, risk disclosure

and firm value. The next part explains value relevance of risk disclosure. Finally this chapter is ended by the differences between risk disclosure in listed and unlisted banks, Islamic and non-Islamic banks. Along with that, this chapter completely explains the independent and dependent variables that will be examined and what the value relevance is, as follows:

Firm Size

Based on agency theory, to minimize asymmetrical information between managers and users and also to reduce agency costs, big companies will report their condition by disclosing more information (Watts & Zimmerman, 1983) and (Inchausti, 1997).

Liquidity

Liquidity ratio is a measurement that demonstrates a firm's ability to pay short term debt. Based on signalling theory, a high liquidity firm will disclose more and show better signals than firms with low liquidity (Elzahar & Hussainey, 2012).

Profitability

The profitability ratio is a measurement to demonstrate the persistence of a company to generate profit. Signalling theory suggests that more profitable firms disclose more to inform their stake-holders about their good performance, but based on agency cost theory, less profitable firms disclose more to contextualize their worse financial performance (Inchausti, 1997). Based on agency theory, companies with higher profit will represent their performance to stakeholders by giving more information and disclose this in their interim report (Elzahar & Hussainey, 2012).

Leverage

Leverage ratio is a measurement for demonstrating a firm's capability to pay long term debts. Agency theory states that firms with higher levels of financial leverage tend to provide voluntary disclosure in order to fulfil creditors' needs and remove the wealth transfer to shareholders (Jensen & Meckling, 1976). According to Elzahar and Hussainey (2012), high leverage firms will disclose more in their reports to indicate good signals in order to show their ability to pay debts.

Earnings Reinvestment

Earnings reinvestment is an earning that will not be paid as dividends to the stakeholders but will be reinvested in their main businesses to support the company's growth. Bodie, Kane, and Markus (2011) argued that firms with a high reinvestment policy will distribute small dividends, nevertheless shareholders will receive high benefits in the future. Companies will pay dividends to compensate investors equal to the level of risk investment. Firms with low level disclosure will pay dividends higher than companies with a high level of disclosure.

Firm Value

As a dependent variable, firm value for listed banks is measured by Tobins Q, while for unlisted banks it is measured by Black Scholes Merton Model. Previous studies have examined the association between firm characteristics with firm value, however the results were vague. Companies which disclose more in mandatory and voluntary reporting to stakeholders can minimise agency conflicts between managers and

stakeholders. This shows that they have a better governance system, hence increasing the firm's value (Sheu, Chung, & Liu, 2010). Big companies have a strong financial motivation to disclose more in order to achieve a good 'corporate standing and public representation' and finally it will increase the firm's value (McKinnon, 1993). While Al-Akra and Ali (2012) found that firm value does not have a relationship with liquidity. But, asset and profitability has a negative association with firm value; meanwhile leverage has insignificant correlation with firm value (Hassan et al., 2009) .

Value Relevance

There is one issue which has not been addressed sufficiently in previous studies; namely value relevance of risk disclosure, particularly in the early stage of capital markets and this is expected to grow rapidly. Disclosing of companies risk performance, providing more detailed and accurate information to the public, it will be valuable and value relevant for users.

Suadiye (2012, p. 302) asserted that "Value relevance is defined as the ability of financial statement information to capture and summarize firm value". According to Agostino, Drago, and Silipo (2011) value relevance is estimated by the degree of explanatory power of the model. In addition, Babaei, Shahveisi, and Jamshidinaid (2013) asserted that value relevance can be reflected by the significance of the coefficients in regression model.

Chapter 5: Research Methodology

This chapter explains the complete process regarding research methodology, hypotheses and methods. To realize the research aim and objectives, this study applies a quantitative research methodology. The first part of the chapter will explain an overview of the chapter. The second part will explain the methodology of this research that employs quantitative research methodology. The third part describes research methods related to the procedures used to gather and analyses data. The population and data period will be explained in the fourth part. While part five will briefly describe dependent and independent variables. Moreover, the sixth part presents the validity and reliability test, and explains how to measure the association between determinants and risk disclosure. The measurement of firm value for listed and unlisted banks will be described in the seventh part. The last part describes the measurement of value relevance. To exhibit the hypotheses, the researcher uses quantitative research methods with statistical analyses namely partial and multiple linear regressions.

Chapter 6: Empirical results and discussion

This chapter concludes the empirical research and discussion which has six parts. The first part is the introduction, while part two will describe the development of banks in Indonesia namely listed banks in the Indonesian Stock Exchange, unlisted, Islamic and non-Islamic banks. The third part will present the data of the extent of risk disclosure in listed and unlisted banks, Islamic and Non-Islamic banks. The fourth part describes the differences between the extent of risk disclosure practices between listed and unlisted banks, and Islamic and non-Islamic banks. The fifth part comprehensively describes the factors affecting a bank's decisions to disclose risk. The result of value relevance of risk disclosure in the Indonesian banks will be presented in the sixth part. This chapter also

comprehensively answers the research questions and discusses the link between the findings and theories and literature reviews. Finally, this chapter will end with a conclusion.

Chapter 7: Conclusion

This chapter concludes this thesis, which highlights the research aim and followed by a brief overview of the findings and answer the research questions, and conclusion. Theoretical and practical implications will be described in the next part. The following part describes the limitation of the research. This chapter will be closed by suggestions for future research.

CHAPTER 2

BANKING IN INDONESIA

2.1 Introduction

In order to set the context for the subsequent analysis and discussion, this chapter focuses on regulations of the Indonesian banking industry. The first part explains several regulations related to disclosure in the banking industry, which is divided into four subparts, namely: the Bank of Indonesia, the Indonesia stock exchange board, Basel II, and IFRS.

Some regulations, particularly regarding risk disclosure, were strengthened in Indonesia after the financial crisis in 1997 and the global economic crisis in 2008. The Bank of Indonesia (the BI) and the Indonesia Stock Exchange regulations asserted that every bank must report their performance through the internet at least annually. Moreover, banks have to disclose their risk to fulfil the adherence of Pillar III on Basel II. Furthermore, IFRS 7 sets out the range of mandatory disclosure that has to be included in a company's annual report.

2.2 Regulations Related To Disclosure

The regulations related to disclosure state that annual reports must be timely, accurate, relevance and appropriate, to simplify user information in assessing banks' financial condition, performance, risk profile, risk management and business activities. Along with this, the BI obliges banks to constitute, provide and publish financial reports, consisting of an annual report, financial report, consolidation, and other publications as well as self-

assessment. In addition, other regulations regarding banks sell their shares in the capital market, they mandatorily have to publish annual reports.

2.2.1 The Bank of Indonesia's Regulations

The BI has issued several regulations regarding transparency, such as Law number 10/1998 which states that a bank is obligated to report on its operations in order to control the condition of banks by the public and the BI; BI regulation number 3/22/PBI/2001 concerning the transparency of banks' financial condition; BI regulation number 5/8/PBI/2003 concerning risk management implementation for commercial banks and its revision number 11/25/PBI/2009; BI regulation number 8/4/PBI/2006 concerning good corporate governance implementation by commercial banks, which promoted transparency in banks' financial and non-financial conditions; BI regulation number 14/14/PBI/2012 concerning transparency and the publication of banks' reports in order to create market discipline in the banking system; to ensure they are in line with the development of international standard; to improve transparency in reporting their performance, and to provide quantitative and qualitative information in their annual reports. Furthermore, the BI issued a risk disclosure regulation number 14/35/DPNP on 10th December 2012 to push banks to report their performance transparently. Banks mandatorily report their performance by releasing annual reports and financial statements every three months, six months and yearly. Banks are able to release their annual report through magazines, newspapers or their websites.

Some regulations have been issued by the BI in order to minimise the risk for banks, such as the Bank of Indonesia's Regulation Number 5/PBI/2003 and 11/25/PBI/2009.

These regulations state that banks have to report eight (8) types of risk related to financing, which are: operation, market, liquidity, strategic, legal, reputation and compliance risk. The Bank of Indonesia's Regulation Number 9/15/PBI/2007, concerns Guidelines for Banks in Implementing and Conducting Risk Management in Integrated Information Technology, including how to manage risk in accordance with the regulations. These are: first, credit risk is the risk caused by the failure of the debtor and/or other parties to meet its obligations to the bank. Second, market risk is the risk on a bank's balance sheet and an administrative account includes transactions of derivatives, due to changes in its entirety from market conditions, including the risk of price option. Third, operational risk is due to the insufficiency and/or malfunction of internal process through human error, system failure, and/or external events affecting the operations of bank. Fourth, liquidity risk is the risk resulting from the inability of a bank to meet maturing obligations to funding sources with cash flow and/or a liquid asset, or high-quality liquid assets that can be encumbered without disturbing the activities and financial condition of the bank. Fifth, risk compliance is the risk resulting from banks that disobey and/or do not abide by the rule of law and regulations. Sixth, legal risks are the risk caused by lawsuits and/or weakness from the juridical aspect. Seventh, reputational risk is the risk caused by declining confidence levels of stakeholders and loss of confidence deriving from negative perception of banks. Eighth, strategic risk is caused by inaccuracy in the acquisition and/or the implementation of a strategic decision as well as failures in anticipation of changes in the business environment. Finally, Business Continuity Plans (BCP) are policies and procedures which contain a series of planned and coordinated actions regarding steps to reduce risks, the handling of the effects of problems/disasters

and recovery processes to ensure that the bank's operational venture and service to customers can still proceed.

In order to support the development of sharia (Islamic) banks, the BI issued several regulations, namely the stipulations of the law of the Republic of Indonesia Number 21 (2008) concerning sharia banking. The circular letter number SE 7/56/DPbS /2005 concerning Islamic banks states that such banks are obliged to publish annual reports and quarterly reports in newspapers and on the Bank of Indonesia's home page. At the least they must report their rights and obligations to related parties, to give a contribution to protecting the bank's assets and to fulfil sharia principles in all transactions, and to provide useful information about the business development and bank's performance to stakeholders.

BI regulation number 11/3/PBI/2009 in clause 35 concerning Sharia Supervisory Board, in the first paragraph mentions that SSB's duties and responsibilities are to give advice and suggestions to the Board of Directors and oversee the activities of banks in order to comply with Islamic principles. The second paragraph states: first, the duties and responsibilities of SSB as referred to in paragraph 1 include: assessing and ensuring compliance with Islamic principles on operational guidelines and products issued by banks. Second, to oversee the process of the bank's new product development. Third, to ask for a fatwa to the national sharia council for a new product that does not yet have an existing fatwa. Fourth, to conduct a review of fulfilment of Islamic principles in the mechanisms of fund collection and distribution, and bank services and finally, to request data and information related to sharia aspects of their work, in order to monitor banks in the implementation of their duties.

2.2.2 The Indonesia Stock Exchange Regulations

Mandatory disclosure is an obligation for companies to release financial reports that are regulated by the chairman of the capital market regulatory body. There are some regulations related to financial report disclosure in Indonesia (particularly for listed companies), namely circulars from the chairman of the capital market, such as number 17/PM/1995, and circular number 38/PM/1996. In addition, the Capital Market Supervisory Agency and the Financial Institution already had a regulation related to disclosure, namely Circular number 02/PM/2002 that listed companies which have to release their performance in the annual report mandatorily. Moreover, the circulars Chairman of Capital Market regulatory body Number SE-02/BL/2008 concerning Guidelines for Presentment and Disclosure of Financial Statements for Public Listed Companies in Mining, Oil and Gas, and Banking, which is designed to govern the presentation and disclosure of financial statements of public listed companies. Another regulation is the type of mandatory disclosure specified in the decision of the chairman of capital market Supervisory Agency and Financial Institution number Kep-134/BL/2006 concerning an obligation to submit annual reports for public listed companies. Moreover, the circulars of the Chairman of Capital Market regulatory body number SE-02/BL/2008 concerning the issuance of financial statements for Public Listed Companies in Mining, Oil and Gas, and Banking. Furthermore, public offerings and public companies must meet the standards of disclosure. Law number 8/1995 article 86 concerning the capital market mentions that to improve transparency and ensure the protection of investors, a company that sells its shares through the capital market shall disclose all the information

about their business, including their financial circumstances, the legal aspects of property management and wealth to the public.

2.2.3 Basel

In order to enhance financial stability and the quality of banking supervision worldwide, the governors of the central banks of the G10 countries in 1974 established The Basel Committee on Banking Supervision (BCBS) under the Bank for International Settlements (BIS), with its head office in Basel, Switzerland. The BCBS not only issues the standard regulations for banks but also provides a forum related to banking supervision. Since then the BSBC has been issuing regulations. They established Basel I concerning the Basel capital accord in 1988, which stated that banks should have a minimum ratio of capital to risk-weighted asset of 8%. In 1996, BSCB issued an amendment to set capital requirements for market risks. After that, in 2008, BCBS released the final version Basel II with three pillars.

The Bank of Indonesia, as a part of more than a hundred central banks in other countries which defer to Basel, has implemented Basel I since 1993. For preparing the implementation of Basel I and in order to promote banking stability, the Bank of Indonesia issued regulation number 5/8/PBI/2003 on 19th of May 2003 concerning the application of risk management for commercial banks. Every single bank in Indonesia mandatorily implements Basel requirements.

Basel II has three “pillars”. The first Pillar is the minimum capital requirement for credit risk in banking, which is calculated in a new way that reflects the credit ratings of counterparties. The second pillar concerns the supervisory review process, and allows

regulators to have some discretion on how rules are applied but seeks to achieve overall consistency in the application of the rules. Finally, the third pillar is concerned with market discipline, and requires banks to increase disclosure to the market of their risk assessment procedures and capital adequacy.

In addition, in some instances, banks have to increase their disclosure in order to be allowed to use particular methodologies for calculating capital. Market discipline imposes a strong incentive on the bank to conduct their business in a safe, sound, and efficient manner. It can also provide a bank with an incentive to maintain a strong capital base as a cushion against potential future losses arising from its risk exposures. To promote market discipline, banks should publicly and in a timely fashion, disclose detailed information about the process used to manage and control their operational risk and the regulatory capital allocation technique they use (BIS, 2003).

Furthermore, the third Pillar is an integral part of the Basel II Capital Accord. It establishes a list of required disclosures that helps investors to get a better picture of a banks' true risk profile. This should enable investors to make more informed investment decisions and based on likely consequence, which creates additional pressure on banks' management teams to monitor their risks closely. The Bank of Indonesia started to adopt Basel II in 2008. In order to support the implementation of Basel II, the Bank of Indonesia released regulation number 14/14/PBI/2012 concerning transparency and publication of bank reports, under which banks must reveal their risks and risk management practices to the public.

2.2.4 International Financial Reporting Standard (IFRS)

International Financial Reporting Standards are issued by the International Accounting Standards Board (IASB). These standard were arranged by the (IASB), European Commission (EC), International Organization of Securities Commissions (IOSOC), and International Federation of Accountants (IFAC). Yuen, Liu, Zhang, and Lu (2009) explained that Indonesia as a part of the IFAC suggests implementing IFRS in local accounting standards.

The objectives of convergence are to make finance information as comparable as possible, to facilitate competitiveness, make analysis easier and to forge good relationships with customers, suppliers, investors and creditors. Implementation of IFRS also helps companies which are listed on international stock markets to report their performance using international standards, without reconciliation to IFRS. The purposes of implementation of IFRS in Indonesia are to make financial reports both easy to be understood and to be used by auditors, accountants, readers and other users. It is also to increase international investors' trust when they invest in Indonesia. It encourages investors to invest in stock markets. With the standardisation of accounting and its implementation by other countries, financial reports have a higher credibility, are more accurate, and this more relevant. Starting from 1st January 2012, the Chartered Accountants of Indonesia launched implementation of IFRS.

The objectives of IFRS 7 require entities to provide disclosure in their financial statements that enables users to evaluate the following: first, the significance of financial instruments for the entity's financial position and performance. Second, the nature and extent of risk

arising from financial instruments to which the entity is exposed during the period and at the end of the reporting period, and how the entity manages those risks. Qualitative disclosure describes the bank's management's objectives, policies and processes for managing those risks. Quantitative disclosure provides information about the extent to which the entity is exposed to risk, based on information provided internally to the entity's key management personnel. Together, this disclosure provides an overview of the entity's use of financial instruments and its exposure to the risks they create (Mirza, Orrell, & Holt, 2008).

All in all, since the experience of the October package in 1988, followed by the financial crises of 1997 and 2008, the Capital Market Supervisory Agency and the BI have not only made improvements and reforms, but also produced new regulations regarding transparency for banks to require them to report their performance in more detail. To make these financial reports compatible with international standards and comparability, and easy to understand and use, the Bank of Indonesia has implemented IFRS for banks. Moreover, in order to enhance financial stability, the Bank of Indonesia has produced regulations which implement the requirements of Basel I-III.

CHAPTER 3

THEORETICAL FRAMEWORKS

3.1 Introduction

This chapter begins by introducing stakeholder theory, and continues with agency theory focusing on the problems it presents in the banking sector. There will be an explanation of the importance of agency theory in relation to the research. It also considers agency cost, how to minimise agency problems, and the relationship between agency theory and a company's performance, ending with a conclusion. The next theory to be considered is communication theory, and the chapter will explain the importance of communication theory for this thesis and the process of communication. Another theory is signalling theory, and the chapter will describe the importance of signalling theory for this research and how signalling started; there is also consideration of the relationship between agency theory and information asymmetry, the importance of signalling theory for firms and investors, signalling in the different types of firms, and problems with signalling. This chapter will close with a conclusion.

Several theories could explain the disclosure phenomena, such as stakeholder theory, agency theory, signalling theory, and communication theory. Nevertheless, in order to explain disclosure supported by only a single theory is not comprehensively enough. Linsley and Shrivs (2000) asserted that to explain the motivation of managers to disclose more of the risks banks face, it would be more relevant when some of the theories are employed as an underpinning theory.

3.2 Stakeholder Theory

This section explains the importance of stakeholder theory in this research. It also describes the definition of the stakeholders and the importance of stakeholders for a company. Firms always deal with the stakeholders who play a crucial role in the company's sustainability. Stakeholders are parties that have a relationship with companies, and as part of this relationship communication with stakeholders must be maintained.

3.2.1 Definition of Stakeholder

R. Edward Freeman was the pioneer of stakeholder theory. His idea was initiated when he was arranging an executive education program in 1978. At that time he was trying to find out how the relationship with stakeholders could be more effective. In their first paper, he and Emshoff defined a stakeholder as "any group or individual that can affect or is affected by the achievement of a corporation's purpose" (Freeman, 2004, p.229). Even though the definition has had some critiques, the idea of stakeholder theory has been developed and it is always needed when scholars examine the relationship between stakeholders and a company.

Post, Preston and Sachs (2002, p.8) stated "stakeholders in a firm are individuals and constituencies that contribute, either voluntarily or involuntarily, to its wealth-creating capacity and activities, and who are therefore its potential beneficiaries and / or risk bearers". In addition, Tencati, Perrini, and Pogutz (2004) argued that stakeholders include employees, member/shareholders, the financial community, clients/customers, suppliers, and financial partners such as banks, insurance companies, government, local

authorities and public administration, communities, even the competitors. In the banking sector the stakeholders include depositors, investors, creditors, borrowers (debtors), bank supervisors, and shariah supervisory boards. The view of a corporation of stakeholders according to Post et al. (2002, p.10) and in combination with Freeman (2010, p.55) is shown in figure 3.1.

Therese (2005) asserted that mass media is a crucial part in the communication between stakeholders and companies. They can be a bridge to connect between companies and stakeholders. Media are able to give information about the companies' activities. Media can even reveal if a company did something bad or lied to its stakeholders. In addition, community has a power to force companies to disclose their performance if the companies did something wrong. Along with that, companies must report their performance honestly and transparently.

3.2.2 The importance of stakeholder theory in this research

In order to know whether the disclosure in annual reports can provide useful information for stakeholders, and whether risk disclosure is value relevant for stakeholders or not, it is necessary to clarify the definition of stakeholders and who they are. Stakeholders in the listed and unlisted banks, Islamic and non-Islamic banks might not be the same; hence, banks should consider who their stakeholders are. Because without understanding who their stakeholders are, companies might not know how to provide the information which meets stakeholders' interests, what information is useful for investors, suppliers, customers, creditors, regulators and other users, and what communication medium is suitable for users.

This theory is useful for supporting the analysis in order to answer the fourth research question, i.e. what is the value relevance of risk disclosure. If the information is fruitful for stakeholders, it means information is value relevant for stakeholders and meets with their interests.

3.2.3 The importance of stakeholders for a company

Sachs et al. (2009) asserted that stakeholders are important for a company; therefore, a company should know the stakeholders' interests. Stakeholders contribute benefit for companies, and get profit from the firm, but stakeholders confront risks and can also represent risks to the firm.

Companies cannot sustain without stakeholders; for example, firms cannot run their operations without support by their staff or employees; firms cannot produce their products if they do not have raw material because they did not have a good relationship with suppliers. Banks cannot collect deposits if the stakeholders did not trust the bank.

When the company achieve a profit and has a plan to distribute dividends, the shareholders might earn a profit from these dividends. Shareholders also can obtain capital gains when the share price increases and vice versa. Nevertheless, when the stakeholders are not satisfied with or do not trust the firm, they might complain and cause harm for the company. They can loudly announce the issue to the public through the mass media and cause a company to have a bad image. Post et al (2002) mentioned that stakeholders are like assets of firms that must be managed and that are a source of wealth to the company.

In figure 3.1, it can be seen that the company has thirteen groups of relationship, who form the stakeholders. The association between company and each group is not only a transactional linkage but also relational. A firm has to maintain and expand good connection with stakeholders as the main link, in order to increase competitive advantages for the firm's sustainability in the future.



Source: Adopted from combination E. Freeman (2010, p. 55); Post et al. (2002, p. 10)

Figure 3-1 The stakeholder of the corporation

3.2.4 Summary

To sum up, the network of relationship with stakeholders is an important asset of firms that must be maintained. There are thirteen kinds of stakeholders, which can be an individual, company, group or organisation that can support the existence of a company; without them a company cannot run well, and they are vital to the firm's long term sustainability. Conversely, they can harm the sustainability of the firm when they are disappointed and do not trust the firm anymore. Along with that, a company should either know what the stakeholders need or build a good relationship and communication with stakeholders in order to ensure the survival of the firm.

3.3 Agency theory

This part explains the importance of agency theory related to the research, what agency theory is, the agency problem, the agency problem in banking, agency costs, how to minimise agency problems, the relationship between agency theory and company performance, and it is closed by a conclusion.

Agency theory is widely used in economics for theorising the underlying relationship between parties with a company or the business practices of the company. The main principle of this theory is that there is a relationship between the parties who give authority (the principals) to other parties who receive that authority (the agents). The shareholders, as the principals, hire and give their authority to managers, as the agents, to manage the company. Due to business development and keen competition, the managers have to manage their companies professionally. In being given responsibility for the progress of their company's performance by their principals, the agents have to make reports

periodically. To measure the company's performance, the principals use financial reports. Hence, the agents are required to disclose financial performance and other relevant information in their financial reports. The principals need more transparent information because they will use the information for making decisions. Nevertheless, agency problems can appear in the relationship between principals and agents.

3.3.1 The importance of agency theory related to the research

Agency theory will be an underpinning theory in this research, and the theory will be the foundation for analysis in answering the research questions. Agency theory is very important to clarify the extent and quality of risk disclosure in the annual reports that provide information and that will be value relevant for users. Furthermore, this research will employ agency theory to explain the association between the determinants of risk disclosures in the banking sector. By disclosing the bank's information, the stakeholders get more information about firm's performance and they are able to make good decisions. Moreover, in describing voluntary risk disclosure, Linsley and Shrides (2006) recommended that agency theory be employed as the underpinning theory.

In addition, Barako et al. (2007) stated that voluntary disclosure in financial reports can be used as an example for the application of agency theory. Managers have more information than users, and they are expected to deliver credible and reliable information for the market. If agents offer complete information, the users can use the information to make an investment decision and thus the information is value relevant for users and it will ultimately increase firm value. Instead, because managers have their own interests, they can sometimes withhold information and do not convey information more

transparently (nondisclosure). Thereby, the investors cannot obtain the necessary information that would affect their investment decision.

Moreover, Healy and Palepu (2001) stated that asymmetric information between principals and users in the agency problem can be minimised by disclosing voluntarily in the financial reports. In addition, Fathi (2013) mentioned that in order to minimise agency conflict, managers can deliver the company's performance information to assure their condition for shareholders and creditors by publishing financial reports transparently. In other words, a conflict between principals and agents can be decreased by disclosing a company's information, meaning that stakeholders are able to employ more complete information for making good decisions and ensuring that the firm's information is value relevant for principals. In addition, agency theory is expected to explain whether there is a difference between the extent of disclosure in the annual reports in Islamic banks, non-Islamic banks, listed and unlisted banks.

Agency and signalling theory are conceptually related, are coherent and able to be amalgamated (Morris, 1987). By disclosing signals in the form of enhancement in the communication of a company's information, it is possible to decrease agency problem, and increase the value relevance of the information supplied for stakeholders. Given this agency and signalling theory will be used for reinforcing answers to the third and fourth research questions.

By doing this research, the result can explain the importance of risk disclosure and transparency in financial reports. By disclosing the financial reports, it will decrease the agency problem between banks and stakeholders; hence shareholders can employ the

bank's valid information in making a good financial decision. In addition, it will provide input for regulators in order to encourage banks to make their performance reports transparently and value relevant for users.

3.3.2 What is the Agency Theory?

Agency theory is one of the underlying theories of research on widespread voluntary disclosure of information. This theory explains the relationship between two parties where one party is an agent and the other is a principal.

Initially, the agency theory was based on Berle and Means (1932)'s opinion. In the corporation, there is a conflict of interest between managers and the owners. For aligning the conflict, the government issues regulations for controlling their interest. The managers have to report firm's performance and give information for the owners. Based on the condition above, then the agency theory was developed by Michael C. Jensen and William H. Meckling in 1976. Jensen and Meckling (1976) stated that agency theory is an association between principals (for example shareholders) and agents (such as managers of companies) where principals give the authority to managers in order to manage the company and to make decisions.

The managers are agents of the shareholders, as owners of the company. The shareholders expect the agents can be relied upon to act in their interests in accruing wealth. Then, shareholders delegate their authority to the managers (agents) to perform their function properly. Along with that, the managers receive incentives and should be supervised appropriately. Supervision can be done through controlling their financial statements, and restriction of management decisions. Those supervisions assure that

managers act consistently in accordance with the contractual agreement with the company's creditors and shareholders.

The expected relationship is mutually beneficial to both parties and there is no conflict between them, but in the process it is possible the agent does not act in accordance with the wishes of the principals or principals do not give the benefit for agents. As the agent, managers have a moral responsibility for optimizing the principals' benefit by receiving compensation as in the contract. Thereby, there are two different interests between principals and agents where each party attempts to achieve their maximum wealth. As the agent, the manager has internal information and a company's prospects in the future more than principals or shareholders. Hence, the manager has an obligation to send a company's performance signals to the shareholders, albeit that occasionally the information is misaligned with its actual condition. This condition induces asymmetric information.

The existence of information asymmetry leads to the possibility of conflict between the principals and the agents. In the organisation, conflict between agents and principals appears because they have different goals among members. It could happen because of human nature. Eisenhardt (1989) highlighted basic assumptions of human nature, namely first, humans in general are selfish (self-interest). Second, humans have limited power of thought regarding future perception (bounded rationality), and finally, people always avoid risk (risk averse). Based on the assumption of human nature, the resulting information from the agent is questionable as to whether the information provided is reliable or not.

3.3.3 The agency problem

The conflict between principals and agent has been explained in agency theory. A relationship between agents and principals leads to conflicts. Agency problems arise because there are different desires between two parties or among participants who have cooperation, for example the managers and employees, bank with debtors and creditors, or managers and shareholders. Jensen and Meckling (1976) argued that the misalignment of interest between agents and principals can generate agency problems because managers will do their jobs for their own interest and benefit and that outweighs the requirement of the shareholders. The conflict could appear because the owners always attempt to increase their wealth by increasing their shares, while agent will not always act as the principals want. There is a separation function between owners and managers hence they have different needs and objectives that will induce conflicts of interest. Moreover, it will encourage information asymmetry in their relationship.

The agency relationship arises when one or more persons (the principals) employ another person (agent) to provide a service and then delegate authority to the agent in making decisions. Moreover, Healy and Palepu (2009), Morris (1987) stated that information asymmetry and agency problems can appear in the relationship between principals and agents. Asymmetrical information appears due to the managers having more internal information about a firm's condition than stakeholders because the principals merely have access to information from financial reports.

Eisenhardt (1989) mentioned that problems in the relationships between principals and agents arise when first, the agent has different interests than the principal, and each party

attempts to maximise their interests and wealth. Agents are supposed to carry out the mandate from principal but they violate commitments by not always acting in the best interest for the principal. Second, it is difficult and expensive for the principal to prove what the agent has done in their business. Finally, the problem of risk sharing happens when the principals and agents have different risks that have to be borne.

McAfee and McMillan (1987) maintained that adverse selection appears because agents do not report the company's performance transparently and hide the information. Along with that, the principals do not have enough information and they are not sure whether the information is accurate and credible or not. This could prevent the principals from making good decisions. Furthermore, Arrow (1971) highlighted that the agency theory could support the emergence of moral hazard. Moral hazard exists due to the agents' reluctance conveying information to the principals transparently, even giving the wrong information. The managers could also possess moral hazard because they deliberately make wrong information available by exploiting information asymmetry for profit. The managers' attitude is one of the factors which affect the decision to make a firm's performance reports transparent. The agency problems in the communication theory are illustrated in figure 3-3.

3.3.4 Agency problem in banking

A bank is an institution that acts as a financial intermediary accepting fund from depositors (creditors) then lending money to other parties who lack funds as a loan (debtors) or to invest in capital markets. Banks do not lend money deposited with them; they create deposits through the act of lending. Werner (2014); McLeay, Radia, and

Thomas (2014); Tobin (1963) explained that a commercial bank also creates money (see figure 4.3); when a bank makes a loan to a borrower and at the same time the money is put in the borrower's bank account. Banks must keep an amount of money as a reserve in the central bank to serve when depositors withdraw their money (fractional reserve), and the remaining money can be distributed as loans.

Conversely, Hasan (2011, p.16) mentioned that "Islamic banks have little option in the matter of credit creation". It is also supported by Papazian (n.d., p.19) who asserted that "the methodology of money market and issuance in the Islamic banks still follow conventional/ non-Islamic methodology". He added that "the principles of Islamic finance have not been applied to the very process of money creation and issuance". Hassan (n.d.) argues that sharia banks cannot create money through a fractional reserve.

Based on stakeholder theory, bank has a relationship not only with the shareholders but also creditors and borrowers. Therefore, the bank faces more complex agency problems which can appear between them. Based on the relationship between them, there are potential agency problems namely asymmetric information, moral hazard and adverse selection. Gow-Liang, Hsiu-Chen, and Chang-Hsi (2006) developed the concept of an asymmetry bilateral information gap model between depositors, bank and debtors, highlighting that agency problems appear both between creditors and the bank, and the bank and debtors. Agency problems exist when creditors do not have enough information for measuring the strength of the bank's capital and it is therefore possible that the bank may become insolvent. In addition, customers cannot intervene in managing the bank; hence this induces the potential for emerging asymmetric information. Creditors are only able to analyse the banks performance from previous

financial information and financial reports. They cannot find out about the banks current performance, let alone future performance.

Due to the existence of information asymmetry, a moral hazard can arise. Moral hazard is a situation where debtors tend to switch their investment. In addition, Jung (2000) mentioned that agency problems exist between borrowers and lenders. Asymmetric information appears in the bank when creditors cannot get information about debtors' characters, quality and willingness to pay the debt. It means that a bank deals with risky funding and credit defaults. Along with that, a bank's actions lead to excessive risk taking or underinvestment, asset depletion, or a decline in the value of collateral (Repullo & Suarez, 2000).

According to Antonio (2001, p. 98) agency problem also appears in the relationship between principals and agent in Islamic banks. The asymmetrical information exists in the mudharabah contract when the creditors (shohibul maal/owner of the funds) have different interest with the debtors (mudharib/entrepreneurs). The entrepreneur may ignore the contract and may not act for the creditor's interest, while the creditor is not allowed to interfere in the management of her/his business and the creditors do not have enough information access. Along with that, the entrepreneur has more information than the creditors and induces asymmetrical information opportunities. In the mudarabah contract, the risk may appear when the mudarib (entrepreneur) does not use the credit appropriately for maximizing for both parties. Finally, it triggers the entrepreneur to undertake moral hazards that are detrimental to the creditor. The risks in the mudarabah contract are quite high. For example, first, side streaming exists when debtors do not use the credit/funds as in the contract agreement. Second, debtors (mudharib) are

negligent and will fully use misconduct. Third, debtors are not honest and conceal the profits. Along with that, in order to minimise the risk due to asymmetrical information, Islamic banks make a clear contract before channelling the credit.

To sum up, banks deal with agency problems between stakeholders particularly in the relationship between the creditors, depositors, banks, and debtors. In the Islamic banks, agency problems can happen between mudharib (the entrepreneur) and shahibul maal (the creditors).

3.3.5 Agency cost

Agency theory states that as the agent of shareholders, managers do not always have the shareholders' interests at heart. Hence, it requires monitors through binding agents, examining financial statements, and restriction in making decisions by management. Those supervisory activities induce agency costs. Moreover, Jensen and Meckling (1976) stated that agency cost consists of first, the monitoring expenditure by the principals. Monitoring costs incurred in principal for monitoring the agent's behaviour, include the cost for controlling agent's behaviour through budget restriction and compensation policy. Second, the bonding cost incurred by agent for ensuring that the agent will not use actions that would harm the principal or to ensure that the principal will be compensated if they do not take a lot of action. Finally, a residual loss is a decreasing of welfare level of the principal after an agency relationship.

Agency costs are used to control manager's activities to ensure the managers act consistently in accordance with the contractual agreement between agents and shareholders. In other words, agency costs arise because of a conflict of interest between

corporate managers, stock holders, and bond holders. Corporate governance mechanism can reduce conflicts between principals and agents. Furthermore, agency cost can be decreased by some mechanisms or manners. Chen, Lu, and Sougiannis (2012) stated that by enhancing corporate governance, the firm is not only able to reduce agency problems but also minimise agency cost. In addition, Sheu et al. (2010) mentioned that differing information between managers and investors can be reduced by disclosure in their annual reports. Companies which disclose more in mandatory and voluntary reporting to stakeholders can minimise agency conflicts between managers and stakeholders. This also shows that they have a better governance system, hence increasing the firm's value. As well as, Fama and Jensen (1983); Fama (1980) highlighted that based on agency theory, best practice in corporate governance implementation can reduce not only asymmetric information between managers and stakeholders, but also mitigate information risk, agency risk and default risk.

Furthermore, Craswell and Taylor (1992) argued that in the agency problem, asymmetric information appears because the agents have more information than the principals. It can be reduced by corporate governance mechanism through disclosure and by making reports transparent. This also induces a reducing agency cost and agency problem, and increases firm value. Corroborating the statement above, Jensen and Meckling (1976) found that agency cost of the companies with high leverage, when most of the equity is from external sources is lower than companies which have low leverage. Furthermore, by decreasing the border between owners and managers in the managerial ownership, it will minimise agency cost. Likewise, Watts and Zimmerman (1983) reported that big

companies will more likely disclose than small firms in order to reduce asymmetric information and agency cost.

3.3.6 How to minimise agency problems

Jensen and Meckling (1976) have explained that managers are the party that are contracted by shareholders for managing the company in the shareholders' interest. Hereby, shareholders give the authority to the manager for making a decision. Along with that, managers must be responsible for what they do for the shareholders.

In order to underpin the relationship between principals and agents, they may make a contract which can bridge and accommodate their interests therefore they should not hide the information which can be used in their interest. Kaplan and Stromberg (2003) mentioned that to anticipate and regulate every potential situation that may arise over the duration of the relationship, firm can make an agreement with a clear explanation of an agents' duties in the contract; however, bounded rationality makes it impossible for the contracting parties to execute complete contracts. Theoretically, agency problems can be eliminated by a complete contract that prescribes and describes each party's rights obligation and authority under all future circumstances.

In addition, differences in access to information between managers and investors can be reduced by disclosure in organisation annual reports. Companies which disclose more in mandatory and voluntary reporting to stakeholders can minimise agency conflicts between managers and stakeholders. Based on agency theory, in order to minimise asymmetrical information between managers and stakeholders and also to reduce agency costs, big companies will report their condition by disclosing more information

(Watts & Zimmerman, 1983). Moreover, Holm and Laursen (2007) reported that asymmetric information between principals and agents induces agency problems and it can be reduced by commitment of managers to report their performance transparently. Furthermore, in order to control if the managers do not act or act out of the contract, it requires a supervision mechanism. In addition, Repullo and Suarez (2000) highlighted that the moral hazard problem between debtors and creditors can be minimised by monitoring the debtor's finance. Voluntary disclosure is a part of the monitoring process.

All in all, agency problems such as information asymmetry, adverse selection and moral hazard can be decreased not only by transparent contracts or agreements between principals and agents, but also by commitment in making voluntary financial reports more suited to disclosure and supervision.

3.3.7 The relationship between agency theory and firm's performance

Despite researchers using agency theory to answer the riddle of the relationship between managers and agents, the results are still in debate. Agency theory mentioned that in order to minimise agency conflict between principals and agents, companies with higher profit will represent their performance to stakeholders by giving more information and disclose the information in their interim report (Elzahar & Hussainey, 2012). Furthermore, Akhtaruddin, Hossain, Hossain, and Yao (2009) argued that agency theory posits a positive correlation between profitability and disclosure. By contrast, Ho and Taylor (2007) reported that disclosure and profitability have a negative relationship. Further, an insignificant impact of profitability on the levels of disclosure was found by Aljifri (2008).

Hence, there are three different perspectives using the agency theory therefore, it is of urgent importance to test the determinants of risk disclosure in the bank sector.

In addition, agency theory states that firms with higher levels of financial leverage tend to provide voluntary disclosure in order to fulfil creditors' needs and reduce the amount of wealth transfer to shareholders (Jensen & Meckling, 1976). Moreover, agency theory suggests a direct relationship between a company's leverage and the comprehensiveness of disclosure. They convey that to satisfy the desires of stakeholders, companies with high leverage will reduce costs and will give more narrative and meaningful information in their annual report. Companies with high leverage want to show that they will not fail to meet their agreements and they therefore disclose more voluntary information.

3.3.8 Summary

Agency problems appear in the banking sector between creditors, banks, debtors, even shareholders. Agency conflict arises when creditors do not have valid information about bank's performance for measuring the strength of the bank's capital and the possibility of the bank's insolvency. Conversely, banks deal with risk, when debtors are not honest and invest their loan into risky businesses. Agency problems are able to appear in the Islamic banks as well. The asymmetrical information exist in the mudarabah contract when creditors (shahibul maal) have different interest to debtors (mudharib / entrepreneurs). Even entrepreneurs ignore the contract and they switch the credit into a risky business, and make a false report.

In order to minimize agency problems, it requires monitoring through binding agents, examining of the financial statements, and restrictions in decision making by management. Nevertheless, those supervisory activities induce agency costs, namely: the monitoring expenditure by the principals, the bonding costs incurred by the agent, and a residual loss. In other words, agency costs arise because of a conflict of interest between corporate managers, stockholders, and bondholders.

Moreover, by reporting their performance with more disclosure, asymmetrical information between managers and users can be minimised. That is why the managers must explain their firm's condition in the annual report more transparently. The companies which report their financial performance transparently will give more information and value relevance for stakeholders. Along with that, shareholders are able to employ the company's information for making a good decision. The companies have to maintain a good relationship between agents and stakeholders as the core linkage, in order to generate competitive advantages for a firm's long term sustainability.

All things considered, due to signalling theory and agency theory having a relationship, this research employs those theories as underpinning theory. The agency theory will be used for explaining the extent and quality of the risk disclosure practice of listed banks, unlisted banks, Islamic banks, and non-Islamic banks. Furthermore, this research gives input for regulators in supporting the importance of risk disclosure to the banks by making financial reports transparently.

3.4 Communication Theory

This part explains communication theory because it relates to delivering a company's information as signals for users through financial reports. But, in conveying information from the agent (sender) to the principal (receiver), problems appear in associating agency theory, signalling theory and asymmetric information (Oliveira, Rodrigues, & Craig, 2011).

3.4.1 The importance of communication theory related to the research

Good communication between firm and stakeholders is essential, related to how the firm sends signals, whether the firm communicates with stakeholders by appropriate channels, whether stakeholders receive the information as what they need, and finally, whether the information is useful for stakeholders. The information about the firm performance can be delivered through annual reports, but in delivering the signals it can be disturbed by noises. Thereby the information or messages could not be accepted by users completely; therefore the information cannot meet what the stakeholders need.

This theory is useful to support the analysis in this study in order to answer the research questions. From the result of the extent of risk disclosure in the annual reports, it can be seen whether banks have sent the information more transparently or not. It means when banks describe their performance with a small number of risk keywords it might connote that they did not send signals and information in more detail, and it could be there is a noise in their communication. Moreover, the information can be misinterpreted by stakeholders and it is not useful for them, therefore it is not value relevant for users.

3.4.2 Communication process

The first mass communication theorist is Harold Lasswell (1948). He suggested a simple theory that communication can be defined as : who, says what, in which channel, to whom and what is that effect. If the theory is applied in this research, then the manager is the 'who', representing the company reporting the firm's performance in the form of annual and financial reports, this is the 'what'; through the web site or regular reports to regulators, this is the 'channel'; financial statements issued for the needs of users, these are the 'whom' which will be used as a material consideration in decision-making, this is the 'effect'. Corroborating with Harold Lasswell theory, Shannon and Weaver drew the communication model as shown in figure 3-2.

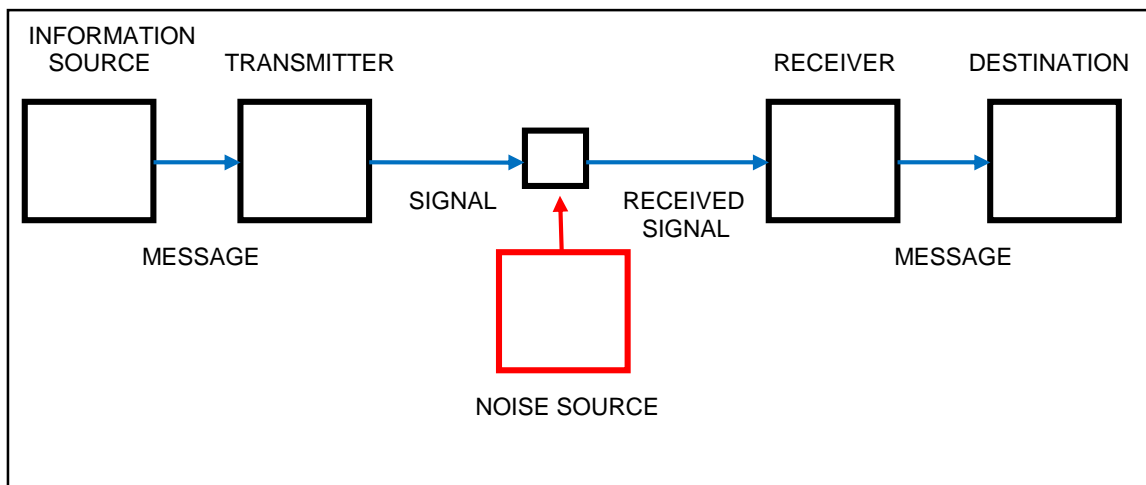

Source: Shannon and Weaver (1948, p. 2)

Figure 3-2 Schematic diagram of a general communication system

Shannon and Weaver (1948) (SW) identified three levels of problems in the communication theory. First, Level A (technical problem): how accurately messages can be delivered? Second, Level B (semantic problem): how symbols can be delivered

precisely as the desired meaning. Finally, Level C (effectiveness problem): how the effectiveness of the received meaning affects behaviour based on the desired manner. The point of each level is to understand how to develop the accuracy and effectiveness of a process. Nevertheless, in reality, there is noise in the communication process that can interfere with the reception of messages. Noise is something contained in a signal during the process of sending and receiving an unexpected message from a source. In the broader concept, noise is anything that is able to make the expected signal more difficult to interpret accurately and noise can affect the way the messages are received.

This theory is very important to clarify the extent and quality of risk disclosure in the annual reports that provide information and that will be value relevant for users. Since communication between company and stakeholders are delivered by many channels, the mode of communication will induce different perceptions in different users, thereby firms have to send information and signals transparently and in more detail. If companies can send and deliver signals of risk information to the markets in more detail and more transparently, it might help users to improve their decisions.

3.4.3 Summary

All in all, the communications are messages or signals delivered by the source (company) to a receiver through channels either directly/indirectly, with the purpose of the source influencing the receivers. Buser and Hess (1986) mentioned the certain elements need to be fulfilled such as: who, says what, in which channel, to whom, with what effect. However, in the delivering process, the communication might be disturbed by noise resulting in different information being received and not in accordance with receiver's

expectations. If the firm can deliver information in more detail, it might help users easily to understand and improve their decisions.

3.5 Signalling Theory

Robert Jervis introduced the term “signals” in 1970 and then they were later defined by Michael Spence (1973). Spence defined signals as manipulative attributes that convey information about the characteristic of the agent (companies) in the market. A signal is the information conveyed by the agent (sender) to the principals (receiver of information) through signs that can give certain indications.

Pertaining to signals, Spence introduced the concept of signalling theory in 1973. The main intention of the signalling theory was to determine whether a signal credibly delivers information (Spence, 1973). Moreover, many studies employ signalling theory to explain disclosure of the firm’s annual reports.

Signalling theory suggests how a company gives signals to users through financial reports. This signal contains information about the results of managers’ activities to realize the owner’s wishes. The signals can be a firm’s performance such as financial and annual reports or other information, which states the company’s prospects are better than others. According to Oliveira, Rodrigues, and Craig (2006), signalling theory in organisations will signal news to investors and other stakeholders through voluntary disclosure.

The manager might send the information but not in accordance with the actual situation. The statements used for camouflage are signals referred to as non-verifiable statements Estrada (2011). Leshem (2012) mentioned that non-verifiable information is an example

of vague signals and a company's annual report delivers the information in the form of a positive/negative signals, good/bad news. Companies deliver the information in order to camouflage bad performance in relation to the firm's condition. Managers convey the signal in order to reject the commitments or promises to make dividends payments to welfare shareholders, because the company has a duty to fulfil it. Although the company has delivered signals through statements in the annual reports, it is very difficult for users to know whether the manager has lied or not.

3.5.1 The importance of signalling theory related to the research

Signalling theory underlines that information is very important in the decision making process for stakeholders. Users perceive that the information by the managers of company will give signals that are essential, because the information provides notes, opinions and explanations about the company's previous, current and future situation. Investors need accurate, relevant, complete and up to date information in the annual reports as a tool for enabling them to consider which investment to choose to create a diverse portfolio and combination of investment based on risk preference. Hence, companies should report their financial statement more transparently.

Signalling will be an underpinning theory in this research, and the theory will be the foundation for analysis in answering the research questions. Signalling theory is very important to clarify the extent of risk disclosure in the annual reports that provide signals and it will be value relevant for users. This research will employ signalling theory to explain the association between the determinants of risk disclosures in banking sectors. However, Linsley and Shrivs (2006) recommend agency theory and signalling theory

as the underpinning theories for describing voluntary risk disclosures. This is corroborated by the finding of previous researchers, Sheu et al. (2010) who used signalling theory for explaining the reason why companies deliver voluntary information to users.

In addition, the signalling theory is expected to explain whether there are different signals related to risks in the annual reports of listed and unlisted banks, non-Islamic banks and Islamic banks. Moreover, this theory became the study's basis for explaining whether mandatory and voluntary risk disclosure reported by the bank provide signals and are relevant or valuable to users.

Furthermore, through the signalling theory, this research is expected to provide evidence of the importance of transparency and disclosure in financial reports. Along with that, the regulators will consider how to enhance the regulation related to the extent of risk disclosure for banks' financial statements. In addition, it will provide input to the regulators in raising awareness of the importance of banks widening their disclosure in financial reports, so reducing the information gap between users and managers.

3.5.2 How did it start

Spence explained the theory by observing the behavior of signalling between jobseeker and employer. The essence of the job market signalling model is that the employer does not have complete information about the ability of prospective employees, which will affect their future productivity, because they add value for employer. The information gap between two parties, employees and employers, generates an information asymmetry.

Spence was influenced by the seminal work done by Akerlof in 1970. Akerlof (1970) explained the information asymmetry by conducting market research on the mechanisms that explain quality and uncertainty. In his article, he used the example of buying and selling new and used cars, dividing them into good and lemon (bad). The sellers have more knowledge about the quality of a car than the buyers. Even though they sell new cars and used cars, the cars can be sold at the same price. Buyers have the opportunity to buy a good used car, depending on the ability of sellers to explain about the car. It means, information is prominent for users not only customers but also firms, stakeholders, investors, regulators, and competitors because information influences them in making a decision.

Dobler (2008) mentioned that economics-shock threat and economic market growth in line with capital market development generate the importance of a company's performance information for investors and prospective investors. In the investment decision-making process, it is assumed that investors employ rational considerations. Therefore, investors require information both externally, such as economic and political factors, and internally, such as financial statements and annual reports. Investors will analyse financial reports through signals such as financial ratios and narrative reports related to a company's previous activities and their prospects in the future.

Studies involving economics and finance engage with signalling theory to explain the reaction of managers, investors and other interested parties when receiving information from the annual report. The signalling theory has interconnected with information asymmetry. Information asymmetry arises when management has more information about the company's prospects, those managers (insiders) generally have, not only more

and better information but also quicker access to a firm's conditions and the outlook of the company than investors. The firms deliver good or bad signals, clear or vague, for users through mandatory and voluntary disclosure in annual reports. In order to minimise asymmetric information, managers should convey information in the annual reports more transparently and disclose to users. However, a firm can choose to disclose information or not in an effort to reduce asymmetry. While a good performance company wants to distinguish itself from a low performance company, they should deliver information more transparently and build credibility through voluntary disclosure. Yet, if a bad performance company delivers deceitful information, it can be uncovered and then users do not believe the company and would consider the credibility of the report to be suspect. Interpretation of the signal of information depends on individual perception and rational. The more informative and transparent the information, the clearer the information will be received and its value understood as relevant for stakeholders.

3.5.3 Relationship between Agency Theory and Information Asymmetry

Signalling theory has a relationship with agency theory and information asymmetry. According to Morris (1987), there are assumptions that can show the relationship among signalling theory, agency theory and information asymmetry. First of all is the need for necessary condition. This condition describes that each person will try to achieve maximum wealth and there is a separation of resource ownership and control. For example here could be a conflict of interest between investors and managers in which investors want to get high dividend whereas managers do not want to distribute their profits because they want to reinvest in order to make more profit. A gap between agent and principal as an agency problem would not appear if those assumptions were

compliant. Second, a separation of ownership and control between managers and investors shows that there is information asymmetry. An occurrence of information asymmetry will generate an agency problem.

Healy and Palepu (2001) argued if investors and managers do business together it complicates and generates two problems: (a) information problems and (b) agency problems. These problems have an impact on financial and annual reports. Therefore, in order to improve these reports, the problems mentioned must be overcome. These two problems can be defined as first, asymmetrical information. Vitezic (2011) asserted that the conflict between managers and investors can appear because manager has internal information more than stakeholders. The manager has an obligation to demonstrate the company's performance to shareholders clearly through the annual report. Nevertheless, that information does not always reflect the firm's real situation. Second, agency problem arises because investors are not active in a management role and delegate too much to the manager. This situation encourages managers prefer to fulfil their own aims rather than do the company's objectives. Consequently, the managers act their self-interest and may make decisions which not accordance with investors' interests.

Signalling theory is fundamentally concerned with reducing information asymmetry between two parties (Spence, 2002). Signalling theory, by contrast, requires information asymmetry. Signalling will appear if an agency problem exists and an agency problem itself needs information asymmetry. The findings of Abraham and Cox (2007) agreed with those of Elshandidy et al. (2011) who stated that managers present more voluntary risk disclosure to decrease information asymmetry in accordance with agency and

signalling theory. To sum up, information asymmetry may appear as a signalling phenomenon and can be minimised by disclosure.

3.5.4 The Importance of signalling theory for firms and investors

According to signalling theory, there are two parties that are interconnected i.e. the company (agent/signaller/messengers) and the user (principal/receiver) as a recipient of information. The essence of the theory is the relationship between the signaller that delivers signals as an insider (such as executive or manager) and who has more information about the company (Spence, 1973), with outsiders (users) who do not have complete information about the company. The manager has good and bad information, and the investor will assume the information is useful as a consideration in making a decision (Connelly, Certo, Ireland, & Reutzel, 2011).

The annual report is one the information types released by a company that deliver signals for users, especially for investors. The information in the annual report includes accounting information relating to the financial statements and non-accounting information that are not related to the financial statements. The annual reports should contain relevant information and disclose information needed by users for taking a decision. The information in the annual report is salient for investors to reduce uncertainty and give reassurance about the prospects of the company's performance in the future. In turn, ensuring the usefulness of narrative information reduces the information asymmetry that arises from an agency relationship between investors and managers. Managers give signals by delivering good and bad news voluntarily. This reduces the cost of reputation damage and prevents decline in share price (Skinner, 1994).

Annual reports provide fundamental information for investors before deciding to buy or sell shares, because a company with a favourable financial condition is likely to see its stock price rise so that the information gives a positive signal to shareholders. When negative stock market shocks happen, firms will deliver information more transparently (Fiechter & Zhou, 2013). The emphasis of signalling theory is on discussing good information in order to deliver the positive characteristics of a firm. A good financial health will ensure stock prices rise, providing the shareholder with a positive signal. However, when the information is negative the stock price will fall providing a negative signal to the shareholder. Connelly et al. (2011) mentioned that in making decisions, according to signalling theory, investors gain an advantage after receiving the signal from the company. For example, the investor will benefit when they buy the shares of a company's that signals good future performance.

Moreover, investors value the information because by getting information they can make more valuable investment decisions. In addition, information can reduce asymmetric information and agency conflicts between managers and investors. In other words, voluntary disclosure provides value relevant information for investors. Signalling theory argues that the company gives signals to the stakeholders in order to enhance its value. Gordon, Loeb, and Sohail (2010) mentioned that by signalling, a company is able to increase its value. The managers disclose voluntary information in the annual report to send signals for investors, thus it is expected to affect stock market value and that is consistent with increased firm value.

3.5.5 Signalling in different types of firms

Eccles (2001, p. 192) remarked that companies with more transparency will increase their credibility in the view of users, because they feel confident with their capability and strategy. Companies will not be afraid to describe their market plans and how well they are doing. Along with that, signalling theory suggests that highly profitable companies will send signals of their quality to investors (Watson, Shrives, & Marston, 2002). Highly profitable firms disclose more and are prone to provide information more repeatedly in their reports due to signalling for adverse selection. Signalling theory suggests that more profitable firms disclose more to inform their stake-holders about their good performance, but based on agency cost theory, less profitable firms disclose more to contextualize their worse financial performance (Inchausti, 1997). Moreover, Elshandidy et al. (2011) stated that large, lucrative companies provide more risk disclosure than small and less profitable companies in order to signal their capability to identify and handle their risks. They found that low profit growth companies reassure users about their prospects of profit and growth through being more transparent in their voluntary disclosure.

In addition, Jensen and Meckling (1976) mentioned that to fulfil shareholders' demand, companies with high leverage provide deliver signals in more disclosure in the form of narrative information in their annual reports. This is because such firms desire to reassure the creditors and show their capability to pay debts.

Despite this, a company suffering from bad liquidity can disclose as much information as possible in order to secure their financial condition by assuring users of their underlying strength, even if they are reporting a poor performance for that year (Wallace, Naser, &

Mora, 1994). Based on the signalling theory, high liquidity firms will disclose more and show better signals than firms with low liquidity. Marshall and Weetman (2007) asserted that there is a positive correlation between disclosure and liquidity. In contrast, (Wallace et al., 1994) revealed that companies with low liquidity will disclose more in order to convince investors, while (Elzahar & Hussainey, 2012) mentioned that the relationship between disclosure and liquidity was an insignificant association.

Fiechter and Zhou (2013) revealed that during turbulent times, small banks in Europe provided more signals and produced longer financial statements as they had to adjust to the big banks' performance. Moreover, the benefit of increased disclosure on small banks was higher than large banks. Based on signalling theory, a well performing company will disclose more information than distressed firms (Ross, 1979). Big companies have a strong financial motivation to disclose more in order to achieve a good corporate standing and public representation and this also shows better news for stakeholders in big companies than small firms.

Signalling theory can explain the relationship between information asymmetry and dividend policy. Dividend payment is a signal for shareholders that illustrates the company's future prospects. Nevertheless, it is possible that information asymmetry may appear between shareholders and management because of changes in dividend payments.

The change in dividend payments affects the stock price reaction in the market. According to signalling theory, share price trends will move upward if dividends increase. Conversely, the stock price will decline, if the announcement of a dividend is downward.

Increasing a dividend payment is a signal for investors that illustrates the company will have better earnings in the future.

Furthermore, Hussainey and Walker (2009) mentioned that investors are able to predict companies' prospects in the future by using dividends as a signal as well as the level of voluntary disclosure. In addition, they also mentioned that companies will pay dividends to compensate investors equal to the level of risk involved in the investment. Firms with low levels of disclosure will pay higher dividends than companies with high-level disclosure. Therefore, based on signalling theory, dividends as a signal can be used to predict a firm's performance in the future and reduce asymmetric information between companies and users. In addition, because of asymmetric information, when the firm is conveying information about the company's prospects in the future, investors should consider dividend information theory. If the companies increase the payment of dividends, investors can assume those signals to be good news and vice versa.

3.5.6 Problem with signalling

Although signalling theory is widely used in finance and management studies, it has been criticized and it has disadvantages. Gray, Owen, and Adams (1996) debated that signalling theory is an example of when managers of companies disguise the fact that the company they work for is not performing well. In addition, signalling theory is difficult to explain when many principals are engaged.

Connelly et al. (2011) mentioned that companies and investors need each other, the signal delivered by the company will be used by the users depending on the quality of information and the extent of lying by the company in its annual reports.

Information asymmetry occurs when insiders or companies generally have more information and quick access about current and future conditions than investors. Due to asymmetric information, investors could find it difficult to assess a company's quality. According to Spence (2002) investors on average perceived companies' performance to be lower when they were unable to understand information or felt it to be insufficient. This condition is called pooling equilibrium because good and bad quality companies will be pooled in the same rating. Moreover, a pooling equilibrium will occur if the users of signals are not able to distinguish between companies, so that signals cease to be useful as sources of information (Spence, 2002). Another drawback of signalling theory according to Aburaya (2012) is that managers have attentiveness in disclosing information.

Another problem with signalling is an agent's failure to adequately pursue the interests of the principles i.e. moral hazard and adverse selection. In providing such information, signals mitigate the potential for moral hazard and adverse selection (Teece, 1996). According to McAfee and McMillan (1987), adverse selection occurs when users cannot perceive the quality of a firm they might invest in, and moral hazard exists when users cannot detect the selected company's actions. A moral hazard exists due to a lack of effort on the part of the agent to convey signals, while adverse selection happens when the agent does not behave in the manner preferred by the principal. Adverse selection problems occur when there is "hidden information", hence users (principals) do not know whether the information that was delivered was accurate or credible (Arrow, 1971). If the signal is weak and principals do not realise, users will tend to assume all of the companies as an average. This condition could lead to high-quality companies

withdrawing from the market rather than getting a negative view of the principals because of such presumptions. Eventually investors will actually be harmed because they are only able to access low quality firms.

Signalling theory could support the emergence of moral hazard. The managers could possess moral hazard because they deliberately made wrong information available by exploiting information asymmetry for profit (Arrow, 1971). Moral hazard is associated with signalling theory when companies with good news disguise the signals. Instead companies with bad news will only pass on information to ensure its condition, for fear of the reaction of competitors (Dye, 1985). In addition, Penno (1997) mentioned that if a company does not have good information they will not convey information, or because they are not sure that the firm's performance will not affect the reaction of users. Furthermore, Okcabol (1993) suggested that in the conditions of competition, a company may not disclose information in a transparent manner because it wants to protect itself from the negative effects by covering or reducing the severity of bad news.

The managers' attitude is the biggest factor affecting the decision to make a firm's performance public. The managers will think through the drawbacks and benefits before delivering the information. They are reluctant to disclose the companies' performance because they worry that competitors will understand their competitive advantage. In addition, Cerf (1961) mentioned when managers make their firm performance reports, they might not understand what the users need.

3.5.7 Conclusion

Signalling theory was introduced by Spence in 1973 through his research on the information gap between employee and employer. Signalling theory is beneficial for explaining the behaviour of managers who have superior access to information compared to investors. Researchers employ this theory to explain the behaviour between agents (firms) and principals (investors) who access information, which is more accessible to company managers.

The company's annual reports contain information that serve as signals required by investors. Investors employ signals as considerations in making a decision. Signalling theory is valuable for companies and investors, because the information delivered by firms provides signals that can reduce information asymmetry. However, the information signs can be good or bad news, incomplete, less transparent or not in accordance with actual performance. Furthermore, there are problems within signalling theory, namely adverse selection and moral hazard. Adverse selection occurs when a company holds information through which investors are unable to ascertain whether the signals are accurate, credible or not. Likewise, moral hazard exists when a company withholds news deliberately or does not convey full information.

A good or bad signal of information depends on the condition of the company. Companies that have good performance may convey information more transparently than a firm with a weaker condition. However, a company with poor conditions could also disclose more in order to convince investors of its financial condition and prospects.

A corporate organization, with high profitability, will send more transparent signals to show the quality of the company to investors. Low liquidity companies are also more transparent in their delivery channels, seeking to guarantee investors of their future performance levels through voluntary disclosure. In addition, companies with low disclosure will pay greater dividends than firms that deliver information more transparently because they consider that the information is employed by investors for predicting the future performance of the company.

Signalling theory will be the theoretical basis of this study because it is used to explain the different types of risk signals shown through mandatory and voluntary corporate disclosure in the annual reports between listed and unlisted banks and between non-Islamic banks and Islamic banks. Furthermore, signalling theory is expected to explain the extent and quality of risk disclosure that conveys signals in the company's annual report that are value relevant for investors. Finally, a company should provide mandatory information and disclose more voluntary information to ensure that information asymmetry between managers and investors is minimised.

Based on the understanding of signalling theory, the theory relies on rational thinking. This implies investors should have the ability to adjust beliefs in order to respond to information and signals in making decisions. In addition, this theory also relies heavily on the receivers' sensitivity to understand signals properly as an opportunity or a challenge. Furthermore, based on their understanding, investors should take a decisive stance in making their financial decisions.

When communication theory and signalling theory are combined, it can be explained that signals comprise delivering information from the sender to the receiver. Because of asymmetric information, in the signals delivery process, there are noises (such as non-verifiable information), problems and obstacles such as adverse selection, moral hazard, pooling equilibrium and camouflage performed by the sender. Thereby, signals cannot be delivered as is expected by users and can be detrimental for users. In addition, users still need to be expert and rational in analysing and interpreting the signals in order to make them relevant and more valuable information. This illustrates that signals in company reports are not direct information (figure 3-3). To sum up, signalling theory is about the use of signals for the transmission of certain classes of information whose primary aim is to communicate information indirectly rather than directly.

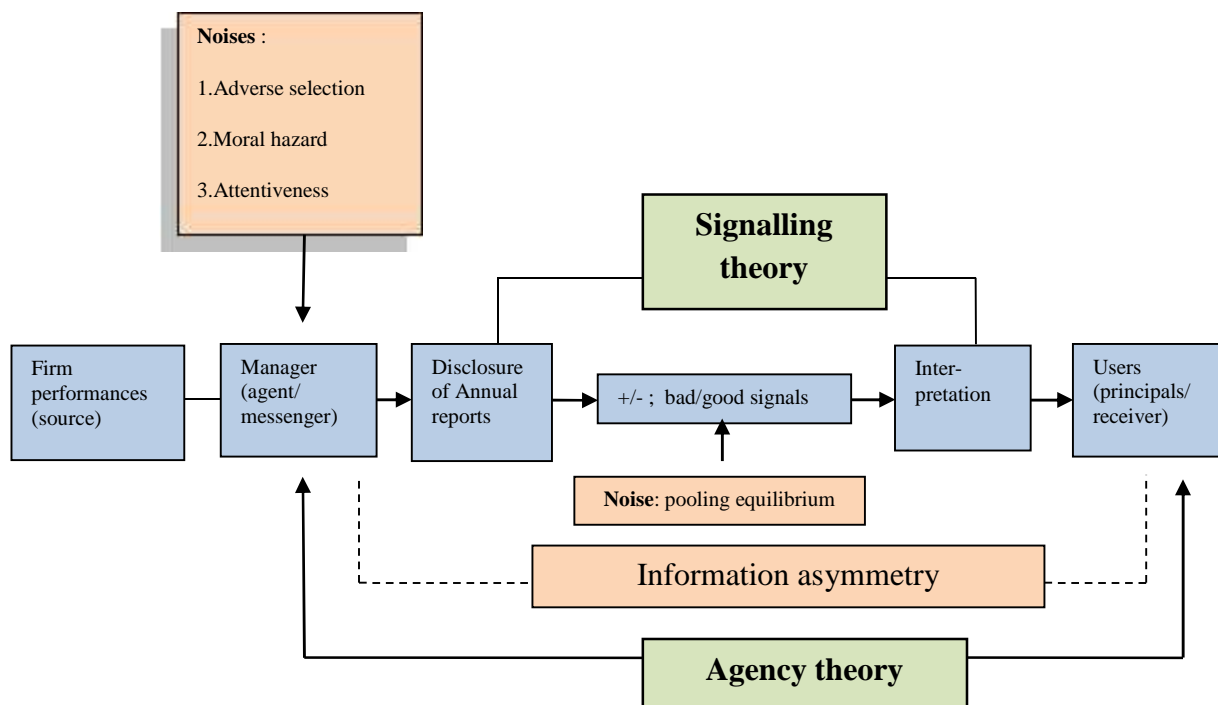

Source: adopted and modified from Shannon and Weaver (1948)

Figure 3-3 The process of signals and noises

CHAPTER 4

LITERATURE REVIEW AND HYPOTHESES DEVELOPMENT

4.1 Introduction

This chapter has seven parts, consisting of an introduction, followed by description risk disclosure, the determinants of risk disclosure, value relevance of risk disclosure, and the differences between listed and unlisted banks, and Islamic and non-Islamic banks. In the section on determinants and value relevance of risk disclosure, the hypotheses are developed based on the gaps in the literature in terms of inconsistent results.

4.2 Risk Disclosure

The use of risk disclosure as the main variable will be described in this part, which consists of six subparts i.e. describes what disclosure, risk, and risk disclosure are. The type of disclosure, the quality of disclosure, and the consequences of risk disclosure.

4.2.1 What is disclosure?

The turbulence and uncertainty of economics mean that stakeholders require high quality corporate information when considering investment decisions. In order to make a good assessment, users need information to be detailed, accurate and transparent. Subramanian and Reddy (2012) mentioned that disclosure occurs when information is released for the public pertaining to companies' activities and performance evaluation. Moreover, disclosure reveals a company's performance as an evaluation of whether the management manages its resources efficiently in the interests of stakeholders (Healy & Palepu, 2001). All in all, disclosure is a kind of communication bridging companies,

managers, shareholders and other users - even competitors- regarding the evaluation of company activities and transparent performance.

The BCBS (1998 p.15) defines transparency as public disclosure that must be comprehensive and reflect the firm's profile. Moreover, the firm information must be relevant to market participants and supervisors. In addition, information must have timeliness and be issued periodically in order for the information to be really fruitful when it is needed by users. Furthermore, information must be reliable, valid, and not lead to misconceptions, and the information in the reports should be easy to compare across banks, countries and time. Finally, each part of the information must be material, and useful as an input for consideration in making financial decisions. All of these criteria must be applied in exploring the information necessary for stakeholders to be able to evaluate and assess a bank's financial performance and its activities, which enables users to measure risks more precisely.

4.2.2 What is Risk?

Frank Knight was the first researcher who triggered a debate about a definition of risk, after publishing his research into probability in 1921. Many definitions of risk can be found. In the Financial Reporting Standard 5 (FRS 5, p. 9), risk is defined as “uncertainty as to the amount of benefits. The term includes both potential for gain and exposure to loss”. Risk can be perceived as uncertainty about the future that can make a loss or a gain for somebody; however, it can be anticipated and mitigated. In accounting terms, risk is the probability or unpredictability of loss. In addition, Shrand and Elliot (1998) claimed that risk could be a kind of threat. Nevertheless risk could also involve

opportunities and all companies must be managed, including banks, because a bank is a financial institution that deals with risks. So banks have to assess, control and manage their risks. Banks and bank supervisors world-wide realize the importance of risk management, because good risk management practices play an important role in the efficacy of banks and the banking system as a whole.

The formal definition of risk, based on the finance perspective, is the volatility of the firm's underlying assets on its equity. The concept of risk from the accounting perception is driven by the value of a firm. The investors are interested in how risky and how volatile those assets of a firm are.

“Risk management is the process by which managers satisfy these needs by identifying key risks, obtaining consistent, understandable, operational risk measures, choosing which risk to reduce and which to increase and by what means, and establishing procedures to monitor the resulting risk position” (Pyle, 1997, p. 2). In addition, according to the Bank of Indonesia Regulation Number 11/25/PBI/2009 concerning risk management is a set of methodologies and procedures used to identify, measure, monitor, and control the risks arising from the business activities of a bank.

4.2.3 What is Risk Disclosure?

Companies, particularly banks as members of a financial industry, deal with risks. In order to minimise risk, stakeholders need more risk information disclosure. By obtaining risk information, users are more confident, less uncertain and able to minimise and mitigate risks before making decisions. Some definitions of risk disclosure have been mentioned by certain researchers. Risk disclosure, according to Linsley and Shrives (2006), is

happening if users receive information about opportunities, hazards, danger, harm, threat, or exposure which has influenced the firm in the past, or this will affect the firm performance in the future. While Miihkinen (2012) defines risk disclosure as information that describes a firm's major risks and their expected economic impact on future performance. Risk disclosure is all the information that firms provide in their risk exposure reviews, and they describe the firm's performance and its risks and how it copes with the risks in the annual report.

Moreover, the Basel Committee on Banking Supervision mentioned that in Pillar 3 of Basel 2, risk disclosure has a positive effect on a bank's performance, hence increasing the banks' competitive advantages in its industry (BIS, 2006).

4.2.4 Types of disclosure

In order to boost trustworthiness, and also to aid stakeholders to assess the firm's condition and strategies, companies have to provide information comprehensively. The annual report is a prime medium for presenting information from the company to users. The annual report consists of a finance ratios, analysis and report by management, and financial report. In addition, an annual report communicates the financial condition and other conditions (non-financial) for the shareholders, creditors, stakeholders and potential shareholders to show the firm's effectiveness in achieving its goals and the corporate responsibility report of the organization (Healy & Palepu, 2001).

As sources of information, financial reports are needed by users for consideration in the making of financial decisions. Providing sufficient information, accurately and fully, is an integral part of financial reporting. However, for the well diversified equity investors, firm

specific risks are relatively unimportant in assessing the value of the firm. In addition, even with the owners of unlisted firms they may well have substantial other equity investments that are highly diversified. As a consequence they are as likely as investors in listed banks to disregard firm specific risk.

Popova, Georgakopoulos, Sotiropoulos, and Vasileiou (2013) mentioned that there are two types of disclosure related to the legal requirements: namely, mandatory and voluntary disclosure. First, mandatory disclosure is the minimum disclosure required and obligated by the regulations. Second, voluntary disclosure is a report which is carried out voluntarily by the company without regulatory stipulation. The company willingly explains other information exceeding the information which the company had already described in the mandatory element of its disclosure report. Voluntary disclosure is disclosure of information that offers more explanation over and above the minimum requirements given in the regulations. Moreover, companies have discretion in conducting voluntary disclosures within their annual reports; as a result, there is a diversity of voluntary disclosure and wide variations between companies. Furthermore, Diamond and Verrecchia (1991) asserted that mandatory disclosure is the revealing of financial reports based on regulations; this disclosure is made by companies before they know the substance of the information. By contrast, voluntary disclosure is the presenting of firm information after a firm has paid attention to the contents and condition of their performance, more than mandatory disclosure.

Extensive disclosures have evolved over time; these may have been influenced by a range of factors: economic development, the social culture of a country, information technology, corporate ownership, or regulations issued by competent authorities.

Stakeholders need additional information in the form of voluntary disclosure, for example: a finance research paper that describes the main characteristics that affect the company's performance, a corporate social responsibility report, or other added value reports (Dragomir & Cristina, 2009).

To eliminate stakeholder doubts, they need additional information. Users therefore increasingly demand that firms voluntarily disclose their resources to enable users to judge a firm's performance and value (Eccles, 2001). Along with that, by fulfilling users' requirements, companies reveal their performance by disclosing voluntarily; hence investors and creditors are able to measure investment risks.

4.2.5 The quality of disclosure

Disclosure of financial statements is a medium of corporate accountability for investors that useful to consider when making decisions. In releasing information, a company has to consider the quality of disclosure. Wallace and Naser (1995) stated that disclosure should first align and be suitable for purpose. Second, information must be informative for users. Third, the firm should convey not only good news but also bad conditions. Fourth, the financial reports should have timelines or periodic reports. Fifth, the information is able to be read easily and understandably by users. Sixth, the information should be related to company risks, and analysis of performance. Finally, the company should release the information completely and comprehensively.

Interestingly, when Muzahem (2011) was doing interviews with his respondents for his thesis, there were some points of view about what constitutes good quality of disclosure, such as: "full disclosure", "relevant", "accurate", "understandable, fair, honest detailed,

complete, meet the need of the users". In addition, Bagnoli and Watts (2005) argued that the quality of disclosure is affected by the managers' intentions, which affects whether they will expose performance transparently or not. Before presenting with the firm's information transparently, the managers might consider what the contents of the information that was reported will be: these contents may depend on the quality of the information they choose to reveal, whether they are presenting bad or good news, and whether it will trigger a firm's value to decrease or increase.

Following the release of IFRS and Basel II, which detail requirements for disclosure in the annual report, and also based on the experience of the financial crisis, conditions support companies to be more transparent in revealing their performance (Höring & Gründl, 2011). Nevertheless, although regulations generally require companies to report their performance transparently, their descriptions sometimes still lack all of the firm's information (Oliveira, Rodrigues, & Craig, 2006). Moreover, Rajab and Handley-Schachler (2009) insist that firms still lack full disclosure in reporting their conditions hence the usefulness and relevance of risk disclosure in the annual reports were be questionable. PricewaterhouseCoopers (2008) found that even though banks must report their performance based on regulations, such as adopting IFRS and BASEL, they still did not reveal their condition completely. Understandably, when there was difficulty in reading and comparing their information it was not considered to be relevant for users.

4.2.6 The consequences of risk disclosure

Providing a disclosure of firm information in annual reports has some consequences, which can be both benefits and disadvantages. Nevertheless, before deciding to release

firm information, managers will consider the costs and benefits of producing and releasing the information, which will be in line with the magnitude of the benefits for the company.

First, Cartwright (2006) stated that customers are able to get information such as products, their prospect in the future, a bank's condition and activities in more detail by reading annual reports. Ariffin (2005) asserted that banks deal with many risks related to their operations: these can be in their transactions, or even deceptive services such bad behavior by their staff or customers, also risks caused by criminals. In doing so banks have to explain their condition in more detail in order to ensure that banks can be trusted and are safe for investing. Moreover, he also mentioned that banks which release risk information more transparently not only help the stakeholders understand the bank's risk profile, but also makes it easier for shareholders to measure risks, so that they can compare and choose banks with good performance and fewer risks.

Second, Botosan (1997) and Healy and Palepu (2001) asserted that by giving transparent company information voluntarily, it is possible to minimise asymmetric information between principals and agents. By disclosing risk information, the cost of capital tends to decrease, which is good for risk management and corporate governance improvement, besides which the users can use the information for exploring company risks (Linsley & Shrives, 2006). Third, based on signalling theory, the company will reveal private information voluntarily to convey bad or good signals, and this may be relevant or irrelevant for investors or shareholders. Fourth, according to Elliott and Jacobson (1994), exploring information more transparently meets investors' needs in

order to give more detailed data and this creates less uncertainty for consideration before making decisions; or a good prediction in the future.

Caruana (2011) asserted that disclosure is necessary not only because economic conditions always change and there is economic turbulence, hence investors need risk disclosure and accurate information for consideration before making a judgment for a good financial decisions, but also because it is good for supervisory agencies in overseeing the banks in order to create a stable financial system.

It has been shown that disclosure of firm performance can decrease the occurrence of negligence that can result in banks failing or a failure in the future (Frolov, 2007). Moreover, the advantage of disclosure is not only to allow investors to choose the bank that has the most efficient portfolio credit, but also disclosure is relevant for reducing uncertainty and making risk estimation low, therefore it can decrease the capital requirements to cover risks (Poshakwale & Courtis 2005). Further, Ariffin (2005) also highlighted that banks who report risks clearly and in detail with financial conditions, not only make it easier for the supervisor to monitor and supervise them, but also to assure that investors and depositors feel safe and confident.

Conveying information more transparently gives advantages for users and the company itself. Abraham, Marstona, and Slack (2014) asserted the analysts can analyse the information deeply and identify the outstanding companies by making forecasts as to whatever they need, for example earnings growth and risks, in order to give recommendations to their clients. While on the investors' side, the information is the most important source for making earnings predictions of profitability more accurate.

They interpret the data to portray a firm's risk profile so that they can anticipate the risks and consider them when making decisions.

On the company side, disclosure makes the cost of capital decrease. Besides, the managers are able to depict what kind of risks they face and how and where the risk level position is. By making a risk profile, companies are able to make risk strategies related to their business strategies by considering the risk level of what they are taking on and the tolerance level, or consider some aspects such as economics and financial conditions, and the structure of organisation (Chakroun & Hussainey, 2013).

Campbell, Chen, & Lu, (2011) found that increased narrative risk disclosure in annual report was associated with a number of market based risk measures. However, their study also found that the usefulness of risk disclosure does not relate to company specific information but to general industry disclosures. Miihkinen (2013) and Kravet & Muslu, (2013) examined the value relevance of risk factor disclosure and found that risk factor disclosure reduces information asymmetry and increases investor risk perception.

The disclosure information in the annual report decreases asymmetric information related to share price (Elliott & Jacobson, 1994). Declining asymmetric information encourages the constriction of bid ask spread, and boosts trade volume, which results in an increase in liquidity. The higher the disclosure, the lower bid-ask spread is, leading to higher trade volume and the higher liquidity, and vice versa.

Disclosure is also able to minimise litigation risk. Litigation risk is a risk that appears because of legal action that can be brought by companies, debtors, creditors or investors. Litigation risk happens due to the debtor/borrower company not acting as noted in the

contract, such as by delaying the payment or not being able to pay the debts. Litigation risk could happen when a company does not give the truth or hides negative information that causes the investors' loss. Litigation risk can be reflected in share price and share volume movement, and also can be measured by the liquidity and solvability ratio.

On the other hand, making information more transparent can also create disadvantages for companies. Even though disclosure gives some pre-eminence, delivering information transparently has drawbacks. First, by disclosing the company's information, it could expose their strategies to their competitors and even decrease their competitive advantages (Darrough, 1993); Subramanian and Reddy (2012), such as technology information (production process, marketing approach), plan and strategy (new target market, product development), and the operation of firms (sales segments, production costs) (Elliott & Jacobson, 1994). Moreover, competitors are able to produce similar products or services or counter product even better, when they read product development plans in the annual report (Elliott & Jacobson, 1994).

Second, reporting a company's performance completely will increase costs and along with that will result in increasing product prices and influencing profit and their performance (Elliott & Jacobson, 1994). In addition, Bhasin (2012) mentioned that even though disclosure in human resources or risk information is able to minimise asymmetrical information, it puts a company at risk when it exposes its marketing strategies, research and development or technology. Also disclosure leads to increased product prices and competitors are able to read a company's strategies.

Nevertheless, disclosing more information generally makes a positive image in the stakeholders' eye, declining asymmetric information, decreasing uncertainty, and it is value relevant for stakeholders in making decisions; this can be achieved by minimising litigation risk; increasing liquidity and supporting the stability of the financial system.

4.3 The determinants of risk disclosure and hypotheses development

The decision of managers to reveal the essence of firm performance means they might consider firm characteristics. Previous research revealed the association between disclosure and firm characteristics; nevertheless the results were mixed and had different conclusions. The firm characteristics can be indicated by size, liquidity, profitability, solvency and other indicators, but this research will employ five determinants that potentially have a relationship with risk disclosure. They are as follows:

Firm Size

Cerf, in 1961, became the first researcher to assert that firm size affects the interim disclosure (Cerf, 1961). Firm size is one of the most important factors impacting the level of risk disclosure. The big companies have more stakeholders than small firms, and have complicated business activities that drive disclosure in more detail. In addition, investors in big companies therefore require more comprehensive reports than small companies' reports, in particular to influence trading of their shares in the stock exchange market.

Based on agency theory, to minimise asymmetrical information between managers and users and also to reduce agency costs, big companies will report their condition by disclosing more information than smaller companies (Watts & Zimmerman, 1983;

Inchausti, 1997). Furthermore, a large company will be able to pay finance consultants and analysts to write the company's report in more detail. Nevertheless, empirical studies do not make a clear association between risk disclosure and firm size, although previous research found a positive relationship between risk disclosure and firm size Hörung and Gründl (2011); Linsley and Shrivess (2006); P. M. Linsley and Shrivess (2005); Rajab and Handley-Schachler (2009). Conversely, Aljifri and Hussainey (2007); Aljifri, Alzarouni, Ng, and Tahir (2014) found a negative association between the level of disclosure and firm size. While, Rajab and Handley-Schachler (2009); Popova et al. (2013) who tested in the UK companies revealed that there is no correlation between risk disclosure and firm size.

In this case, the association between risk disclosure and firm size remains unclear. Based on agency theory, Watts and Zimmerman (1983) stated that big companies have more complicated business hence they will disclose more than small firms in order to minimize asymmetric information between managers and users. Along with that, this research supposes larger firms have a strong motivation to disclose more information and reduce risk uncertainty.

Based on those explanation, (H1): There is a positive association between the delta of risk disclosure and the delta of firm size.

Liquidity

Liquidity is an ability of corporate management to generate liquid funds to meet immediate obligations such as payments to suppliers and employees, and longer term, for example debt repayments (Lee, 2006). In addition, liquidity ratio is a measurement

of a firm's ability to pay short term debts and when the payments become due. A company with a high liquidity means that the firm has a capability to pay short term debt (Ward, 2009). Moreover, liquidity is also able for predicting asymmetric information between managers and shareholders (Barakat, Chernobai, & Wahrenburg, 2014). They also asserted that a company with a more transparent performance report not only generates the increasing of liquidity, but also has a robust trustworthiness by stakeholders such as supervisory board, regulators, shareholders and depositors. As a generalisation, it can be calculated as current assets divided by current liabilities.

Appendix A shows some research relates to the association between disclosure and liquidity, nevertheless it has different results. Espinosa, Tapia, and Trombetta (2005); Marshall and Weetman (2007) found a positive significant correlation between liquidity and disclosure.

By contrast, Bamber and McMeeking (2012) mentioned that when firms have lower liquidity, they will disclose more and be aware of information in order to minimize information costs. Furthermore, Wallace et al. (1994) asserted that the relationship between disclosure and liquidity was negative significantly. While Agyei-Mensah (2012), Elzahar and Hussainey (2012) asserted that the relationship between disclosure and liquidity is insignificant. Thus, the association between risk disclosure and liquidity is not clear. Yet, Marshall and Weetman (2007) highlighted that based on the signalling theory, the high liquidity firms will disclose more and show better signals than the firms with low liquidity.

Along with that, then this research supposes (H2): There is a positive association between the delta of risk disclosure and the delta of liquidity.

Profitability

Profitability ratio is the persistence of a company to generate profit. Signalling theory suggests that more profitable firms disclose more to inform their stakeholders about their good performance, but based on agency cost theory, less profitable firms disclose more to contextualise their worst financial performance (Inchausti, 1997). Moreover, a profitable firm manager will show their capability to cope with risk by presenting risk information (Elshandidy, Fraser, & Hussainey, 2013). Furthermore, Barako et al. (2007), (Uyar & Kiliç, 2012) found profitability has a significant positive impact on disclosure level. Mathuva (2012) corroborates the finding that profitability is also significant and is positively related to disclosure, which seems to suggest that more profitable firms disclose more. On the other hand, Elzahar and Hussainey (2012) explained that profitability and disclosure of a firm's information in the interim report has an insignificant association. In addition, Aljifri et al. (2014) argued that there is no correlation between disclosure and profitability. Thus, association between profitability and risk disclosure is vague.

Meanwhile based on the signalling theory, companies with high profit will show their performance by sending good signals to assure investors that the companies have good finance (Watson et al., 2002). Moreover, Inchausti (1997) claimed that based on agency theory, companies with high earning will disclose more in their annual report.

Referring to signalling theory then, this research supposes (H3): There is a positive association between the delta of risk disclosure and the delta of profitability.

Leverage

Leverage or solvency is an ability of the firm to survive in the long run. Leverage is viewed as a result of events that determines companies' source of financing to run the business. Leverage or solvency is a term often used by companies to measure the company's ability to meet their entire financial obligations if the company is liquidated. Leverage describes the relationship between shareholders' equity and long term debt and the ability to indicate the degree of risk to shareholders by long term debt (Lee, 2006).

A company with a high leverage/gearing ratio indicates that total debt is higher than total assets and that the company is not solvent (Horne, 1997). If there are companies that have high asset and high leverage, it shows that such firms face high risk. In that condition, investors would not invest in the company because they would be concerned that higher asset is derived from debt, thereby increasing investment risk due to the company being unable to pay debt on time. In addition, companies with small debt show low leverage and tend to have low risk bankruptcy (Khan, Kaleem, Nazir, 2012) . This may imply that a company with low leverage has the ability to survive longer and vice versa. It is plausible that leverage is a signal that should be disclosed in the annual report which can provide a company's business continuity information in the long run.

According to Jensen and Meckling (1976), agency theory suggests a direct relationship between a company's leverage and the comprehensiveness of disclosure. To satisfy the desires of stakeholders, companies with high leverage will reduce costs and will give

more narrative and meaningful information in their annual report. Companies with high leverage will show that they would not disobey their agreements and disclose more voluntary information. In addition, agency theory states that firms with higher levels of financial leverage tend to provide voluntary disclosure in order to fulfil creditors' needs and give a wealth to shareholders (Jensen & Meckling, 1976).

Naser et al. (2002) asserted that high leverage firms will disclose more in their reports to indicate good signals in order to resolve their debts. Previous research on the association between risk disclosure and leverage offers contradictory results. Rajab and Handley-Schachler (2009); Elzahar and Hussainey (2012) corroborate the ideas of Linsley and Shrivies (2006) who suggested that leverage and risk disclosure has no significant association. On the other hand a positive association between leverage and aggregated risk disclosure have been found by Marshall and Weetman (2007); Ibrahim (2011); Popova et al. (2013). Conversely, Dobler, Lajili, and Zéghal (2011) argued that leverage and risk disclosure in the manufacturing sector in Germany has a negative relationship. Thus, the association between disclosure and leverage is obscure. Nevertheless, agency theory states that firms with higher levels of financial leverage tend to disclose more information voluntarily in order to satisfy creditors and remove the suspicions of wealth transfer to shareholders (Jensen and Meckling, 1976).

Referring to agency theory this research supposes (H4): There is a positive association between the delta of risk disclosure and the delta of leverage.

Earnings Reinvestment

Dividends are payments from the company's earnings to the shareholders either cash or stock because they have invested their money in the company's equity (S. Ross, Westerfield, & Jordan, 2008, p. 591). The investment objective of shareholders is to improve wealth and to obtain returns. On the other hand, the company's management intends to increase corporate value. Dividends are still debated, the companies perceive giving high dividends is good for shareholders and company, on the other hand paying low dividends is good as well.

Dividend policy is the determination of the profit portion that will be paid to shareholders. The amount of the dividend depends on the dividend policy of each company. If a company has a high dividend it will increase the share price and finally increase the firm's value. Along with that, shareholders need dividend policy information to assess and analyze the possibility of return that would be obtained if they invest in that company. Roden and Stripling (1997) mentioned that a decision of dividend payments policy is an important thing concerning whether cash flow will be paid to investors or will be retained for reinvestment. A dividend reinvestment plan means that the firms will not pay dividends but the company will reinvest the fund by issuing shares.

According to Bodie et al. (2011, p. 593), in the growth prospect, there are two dividend policies. First, a low reinvestment rate plan, a dividend policy that the company pays a higher dividend at the beginning of the period but the dividend growth will be lower in the future. Second, a high reinvestment rate plan, the company will provide lower dividend at the beginning of the period because the company will invest some of the profits for expansion (reinvestment). However, with this policy, investors will receive a higher dividend in the future.

Meanwhile, according to the dividend irrelevance theory by Miller and Modigliani (1961), dividend policy does not have an effect on firm value and cost of capital. They believe that a company's value will only be determined by the ability to generate profits and business risk. Nevertheless, Baker & Powell (2012) mentioned that management pays more attention to dividend policy because it can affect firm value and shareholder wealth. The managers of Indonesia Stock Exchange companies perceived that dividend policy influences firm value. Whereas, Lintner (1956) stated that dividends policy as "the bird in the hand", means investors prefer to receive dividends than capital gains. According to them, investors perceive dividend yield as more certain than capital gains yield. On the contrary, Litzenberger and Ramaswamy (1979) argued that due to the tax advantage of dividends and capital gains, investors prefer capital gains because it can delay the payment of taxes.

Another theory, the Clientele Effect states that the group (clientele) of shareholders has different preferences on dividend policy. They mentioned that a group of shareholders who need income now prefer a high dividend payout ratio. On the other hand a group of shareholders who do not need money now prefer to hold the company's net profit. Moreover, if there is a difference in taxes for individuals, the shareholders who are higher taxed prefer to defer capital gains. It means that they prefer if the company pays small dividends. Instead a group of shareholders who are taxed relatively low tends to prefer to receive big dividends.

The signalling hypothesis states that if the dividends increase, it will be followed by a rising of share prices and vice versa. According to Miller and Modigliani (1961), increasing of dividends is usually a signal for investors to show the company is foreseen

to have a good income in the future. The investors believe that the decreasing or increasing of dividends from the normal rate is a signal that the company will face difficulties in the future.

An additional capital requirement is increasing in line with development of the company. The company has alternatives to fulfil capital by increasing the number of shares by issuing new shares or debt. If the company chooses the first alternative, there are several ways it can be done, for example: selling shares to the existing shareholders, selling shares to employees, issuing shares to the public in the stock market or adding stocks from not shared dividends (dividend reinvestment plan).

Moreover, Bodie et al. (2011) stated that companies which distribute large dividends initially will have low reinvestment opportunity and in the future dividend growth rate will be low. Conversely, if the company has an earning reinvestment policy, while initially investors will receive small earnings, in the long-term investors get benefits by receiving high dividends thereby increasing the value of shares (figure 4.1). In other words, the companies with a high reinvestment rate generate higher dividends. Finally it will boost firm value.

Companies will pay dividends to compensate investors equal to the level of risk of their investment. According to Baker and Powell (2012), to compensate for a high risk investment, firms which have low disclosure are expected to pay higher dividends. However while they expected that firms with low level disclosure will pay more dividends than companies with a high level of disclosure, they actually found a positive relationship between the quality of disclosure and dividend per share. Thereby, the company which

has a reinvestment policy should disclose more in order to make sure the investors, by reinvesting the earnings, will give them higher earnings in the future.

Corroborating with Baker and Powell (2012) then, this research supposes (H5): There is a positive association between the delta of risk disclosure and the delta of earnings reinvestment.

Based on the agency theory, signalling theory, prior research and also considering the relationship between risk disclosure and firm's characteristics i.e. firm size, liquidity, profitability, leverage, earnings reinvestment, this research adopts the following (H6): there is an association between the delta of risk disclosure and the delta of firm characteristics.

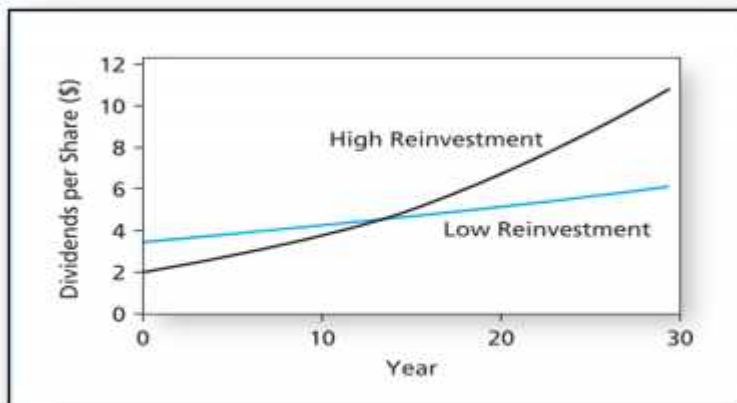

Source: Bodie et al. (2011, p. 593)

Figure 4-1 Dividend growth for two earnings reinvestment policies

Firm Value

The firm value of listed companies can be determined by the mechanism of demand and supply in the market, which is reflected by share price. The higher stock price makes the value of companies higher. In addition, the main goal of the company is to maximise the wealth of shareholders or firm value. Hence, the business managers always try to demonstrate their performance and to make sure that their companies are attractive for a good alternative investment.

Differing information between managers and investors can be reduced by disclosure in their annual reports. Companies which disclose more in mandatory and voluntary reporting to stakeholders can minimise agency conflicts between managers and stakeholders. In addition, if companies have a better governance system by revealing firm performance more transparent, hence increasing the firm's value (Sheu et al., 2010). In addition, Jensen and Meckling (1976) asserted that firms with low transparency will have a high level asymmetric information, and decrease the firm value.

McKinnon (1993) asserted that big companies have a strong financial motivation to disclose more in order to achieve a good 'corporate standing and public representation' and this also means better news for shareholders in bigger companies rather than small firms. Finally it will increase the firm's value.

Firm size influences the value of the company, because big companies find it easier to obtain sources of funding both internally and externally (Al-Akra & Ali, 2012). In addition, big total assets can be used for financing the company's operations and the managers have more flexibility in using assets in the company. If management is able to manage the assets productively, it will improve company performance and finally increase firm

value. Along with that, the following (H7): There is a positive association between the delta of firm size and the delta of firm value.

Agency theory asserted that liquidity has a positive relationship with firm value. A company with high-liquidity increases a company's value because the firm has high cash reserves, which supports the capability to pay the company's short-term liabilities and has a positive impact on firm value. Nevertheless, Al-Akra and Ali (2012) did not find that liquidity has any association with firm value. Therefore, the following (H8): There is a positive association between the delta of liquidity and the delta of firm value.

Moreover, firm value can be influenced by profitability Uyar and Kiliç (2012). Stakeholders perceive that profit from sales and investment can generate a high profitability ratio. Rising profit from year to year shows an increase in the company's net income that indicates that the value of the company rises. If net income increases, eventually stock price will increase and arguably it increases firm value. A company with high profit can attract investors, generate the share price increase and finally increase firm value.

Therefore (H9): There is a positive association between the delta of profitability and the delta of firm value.

The amount of leverage can be considered as a predictor of company risk, it means that the greater the leverage, the higher the debt, indicating a greater investment risk. Along with that, leverage has a relationship with firm value. Companies with high leverage convey a negative sign that supports a negative reaction for users which then ultimately affects the value of the company. Accordingly, the firms with low leverage increase firm

value and the risks are smaller than the companies with high leverage. Nevertheless, previous researchers had different results, such as Hassan et al. (2009); Uyar and Kiliç (2012) who mentioned that there is no relationship between leverage and firm value. Meanwhile, Babaei, Shahveisi, and Jamshidinavid (2013) found that leverage has a negative correlation with firm value.

This research supposes that banks with high leverage show a high risk and convey a negative sign to stakeholders and it will affect firm value decrease. Hence, leverage has a negative correlation with firm value.

Therefore, the following (H10): There is a negative association between the delta of leverage and the delta of firm value.

Bodie et al. (2011) stated that companies which distribute large dividends initially will have low reinvestment opportunity and in the future dividend growth rate will be low. Conversely, if the company has an earning reinvestment policy, while initially investors will receive small earnings, in the long-term investors get benefits by receiving high dividends thereby increasing the value of shares (figure 4.1). In other words, the companies with a high reinvestment rate generate higher dividends in the future. Finally it will boost firm value.

The following (H11): There is a positive association between the delta of earnings reinvestment and the delta of firm value.

Previous research showed that there are determinant factors involved in the relationship between disclosure and firm value. Some studies have shown different results with

regard to the relationship between disclosure and firm value based on signalling theory in the banking sector. Hassan et al. (2009) concluded that voluntary disclosure has a positive but insignificant association with firm value. They also asserted in their conclusion that mandatory disclosure is significant but has a negative relationship with firm value with controlling factors, namely asset size and profitability. Al-Akra and Ali (2012) indicated that voluntary disclosure is positively associated with firm value.

Therefore, the following (H12): there is a positive association between the delta of risk disclosure and the delta of firm value.

Agency theory predicts that firm characteristics namely firm size, liquidity, profitability, leverage, earnings reinvestment influence firm value. In addition, signalling theory asserted that disclosure has a relationship with firm value, then the following (H13): there is an association between the delta of firm value and the delta of company characteristics and the delta of risk disclosure.

4.4 Value Relevance

Previous research showed that there are determinant factors involved in the relationship between disclosure and firm value. Some studies have shown different results with regard to the relationship between disclosure and firm value based on signalling theory in the banking sector.

Francis, LaFond, Olsson, and Schipper (2004) asserted that value relevance is one of the basic attributes of the quality of financial statements. In addition, Suadiye (2012, p. 302) stated that “value relevance is defined as the ability of financial statement information to capture and summarize firm value”. Moreover, Barth, Beaver & Landsman

(2001 p.4) stated that “an accounting amount will be value relevant, i.e. has a predicted significant relation with share prices, only if the amount reflects information relevant to investors in valuing the firm and is measured reliably enough to be reflected in share prices”.

The earlier researchers, Anandarajan, Francis, Hasan, and John (2011); Uyar and Kiliç (2012), mentioned that because voluntary disclosure influences firm value, it means voluntary disclosure is value-relevant. In addition, Moumen, Othman, and Hussainey (2013) asserted that transparency of a firm’s condition in the annual reports is valuable and value relevant for investors, it can even be used for predicting the changes of earnings in the following two years ahead. Moreover, they mentioned that companies which voluntarily reveal more information and describe their performance transparently by narrative explanation will give more information for users about a possibility to get profit and firm’s risks. Furthermore, firm disclosure will be more fruitful for stakeholders and more significant when it is supported by regulation such as adoption of IFRS (Kar in, 2013).

Based on agency theory, by providing a firm’s information about more disclosure, asymmetric information between managers and users will decrease. In other words, by disclosing voluntarily, companies provide more detailed and accurate information to the public, hence this is valuable and value relevant for users. All in all, risk disclosure through published financial statements is essential for users, it means it has value and relevance for investors.

Based on the statement above then (H14) is risk disclosure is value relevant for stakeholders.

Some prior studies in Middle East countries such as those by Hasan et al. (2009); Al Akra and Ali (2012); Uyar and Kilic (2012) have examined the value relevance of disclosure, and the association between disclosure and firm value, in the listed companies

In order to know the value relevance of voluntary disclosure, Uyar and Kilic (2012) examines 131 listed manufacturing companies on the Istanbul Stock Exchange but only used data for the year 2010. They tested control variables namely disclosure, size, leverage, profit, growth with firm value, for which firm value were proxied by market capitalization, market capitalization six months after year end, market capitalization to book value of equity, and market value to book value of equity six months after year end. Voluntary disclosure was measured by a disclosure index. Their result showed that voluntary disclosure has a significant positive correlation with firm value, meaning that voluntary disclosure is value relevant.

Hassan et al.(2009) examined the value relevance of non-financial firms in Egypt and concluded that voluntary disclosure has a positive but insignificant association with firm value. They also asserted in their conclusion that mandatory disclosure is significant but has a negative relationship with firm value with controlling factors, namely asset size and profitability. Their empirical results showed that voluntary disclosure has a positive insignificant association with firm value.

Al-Akra and Ali (2012) indicated that voluntary disclosure is positively associated with firm value, but it has a negative relationship with mandatorily disclosure; there research

was conducted in Jordan. They employed 243 non-financial listed companies in the Amman Stock Exchange and compared the firms between before and after privatisation. They also tested firm characteristics viz size, profitability, leverage, growth and industry type. Firm value was measured by the market value of equity to the book value of equity, meanwhile voluntary disclosure was measured by voluntary disclosure index. They tested the relationship between firm value and disclosure in three criteria based on mandatory disclosure; voluntary disclosure, and mandatory and voluntary disclosure.

This recent study differs from previous research because their sample comprised listed companies in the Middle East, while this current study was done in Indonesia with unlisted and listed companies as the population. We have the same independent variables such as size, liquidity, profitability, leverage and disclosure, but they did not test earnings reinvestment. This is the first study to have examined a relationship between earnings reinvestment and disclosure and firm value, prior studies employed dividend.

Moreover, Uyar and Kilic (2012), Al-akra and Ali (2012), Hassan et.al. (2009) examined the value relevance of mandatory and voluntary disclosure in the non-bank annual report over the period in 2010; 1994-2004; 1995-2002 respectively, meanwhile this current study tested risk disclosure of Indonesian banks' annual report above the period 2008-2012 and compared listed and unlisted banks, Islamic and non-Islamic banks. Moreover, risk disclosure was measured by number of sentences which have at least one risk keyword divided by total number of Indonesian sentences, whereas prior studies employed disclosure index. The firm value for listed companies was measured by market capitalisation (Uyar & Kilic, 2012) or market value of equity to the book value of equity (Al-Akra & Ali, 2012); (Hassan et al., 2009), but this current study employed Tobins' Q.

Due to none of previous study measuring firm value for unlisted banks, this is the first research measured firm value for unlisted bank by Black Scholes Merton model.

Some researchers, Popova et.al. (2013), Elzahar and Hussainey (2012); Marshall and Weetman (2007); Linsley and Shrivess (2006) examined the determinant of disclosure in the UK listed companies by using size, profitability, liquidity, and leverage as the same as this current study. Nevertheless, they did not compare between listed and unlisted companies and Islamic and non-Islamic companies, whereas this current study tested those groups.

Popova et al. (2013) used disclosure index was used for measuring disclosure in annual report; but Marshall and Weetman (2007) measured disclosure by counting sentences; while, Elzahar and Hussainey (2012) employed content analysis. This current study is different with those prior studies and this is the first researcher using Indonesian risk keyword.

This study has some unique characteristics, which differ from prior studies in the following ways: first, employing number of Indonesian risk keyword divided by total number of Indonesian sentences in the Indonesia banks annual report for measuring risk disclosure. Second, earnings reinvestment was used as the determinant of disclosure. Third, employing Black Scholes Merton model for approaching firm value in the unlisted banks. Four, comparing the determinant and value relevance of risk disclosure between listed and unlisted, Islamic and non-Islamic banks.

The resume of previous research results is presented in appendix A. Based on the explanation above, the resume of research hypotheses and predicted signs are provided in table 4-1.

Table 4.1 Research Hypotheses and Predicted Signs

Hypothesis	Expected sign
H1: There is a positive association between the delta of risk disclosure and the delta of firm size	+
H2: There is a positive association between the delta of risk disclosure and the delta of liquidity	+
H3: There is a positive association between the delta of risk disclosure and the delta of profitability.	+
H4: There is a positive association between the delta of risk disclosure and the delta of leverage.	+
H5: There is a positive association between the delta of risk disclosure and the delta of earnings reinvestment	+
H6: There is an association between the delta of risk disclosure and the delta of firm characteristics.	+/-
H7: There is a positive association between the delta of firm size and the delta of firm value	+
H8: There is a positive association between the delta of liquidity and the delta of firm value	+
H9: There is a positive association between the delta of profitability and the delta of firm value	+
H10: There is a negative association between the delta of leverage and the delta of firm value	-
H11: There is a positive association between the delta of earnings reinvestment and the delta of firm value	+
H12: There is a positive association between the delta of risk disclosure and the delta of firm value	+
H13 : There is an association between of the delta of firm value and the delta of company characteristics and the delta of risk disclosure	+/-
H14: The risk disclosure is value relevant for stakeholders	

4.5 The differences between Listed and Unlisted banks

In order to raise funds, companies are able to finance from internal or external resources. Based on Pecking Order theory, Myers and Majluf (1984) mentioned that firms prefer to use internal sources from retained earnings for financing their business, but if these are still not enough they will cover it from external debts. In order to get more funds, as the last resort they can sell shares in the equity market which is organised through a stock exchange.

When firms register and have a right to sell their shares to the public on the stock exchange, their status changes from private companies to public companies, from whom any individual or company or group is able to buy shares and thereby invest in and own a part of a company. When shares are listed on the capital market, they become a public company or listed company and their name is added by "Tbk" (terbuka) for listed firms in Indonesia.

In general, when companies decide to issue shares to the public, they have several objectives: as a result, the benefits and consequences are borne by the company. Listed companies must comply with regulations in order to protect shareholders. The regulations provide governance of securities transactions on the capital market. Moreover, listed companies must report their performance transparently through financial reports regularly, at least every single year. In addition, listed firms face the consequence of being monitored by stakeholders such as: shareholders, regulators, media. In addition, Wallace et al. (1994) highlighted that listed companies will disclose more in revealing their performance in the financial reports than unlisted firms.

Meanwhile, unlisted companies' capital is funded from internal resources and their investments depend on their internal resources, to a greater extent than listed firms. Moreover, Schoubben and Rulle (2004) argued unlisted companies usually have a higher debt financing and leverage than listed firms.

Most previous researchers have examined the disclosure in the listed companies, a very little of research has used unlisted firms for their sample. Aljifri et al. (2014) employed 106 listed and 7 unlisted firms in UAE in 2005 to analyse the correlation between the extent of financial disclosure and firm characteristics (appendix A). Nevertheless, the prior study did not compare either the extent of disclosure or the relationship between dependent and independent variables comparing listed and unlisted firms. The extent of disclosure was proxied by disclosure index, and they asserted that disclosure index was not an adequate measurement to capture the extent of disclosure. The result showed that size (market capitalization), profitability (ROE) and liquidity (current asset/current liabilities) had an insignificant association with disclosure. The listing status and type of industry (i.e. banks), have positive relationship with disclosure. Meanwhile, the current study distinctively used the number of sentences which have at least one Indonesian risk keywords divided by number of Indonesian sentences in bank annual report over the period 2008-2012. None of the previous researchers examined risk disclosure in listed banks and unlisted banks, Islamic and non-Islamic banks, but this current study tested the differences of risk disclosure in listed and unlisted banks, Islamic and non-Islamic banks.

Ibrahim, Ismail and Zabaria (2011) described the interrelationship among disclosure, risk, and Islamic banks performance in Malaysia, namely size, profit, leverage, total financing

(fin), and non performing finance (NPF) by equation approach. First, the determinant of disclosure at time t. Second, the effect of disclosure, profit, fin, and NPF on Leverage. Third, the effect of disclosure and leverage on profit. Disclosure was measured by disclosure index. Their research used voluntary disclosure theory, legitimacy theory, political economics theory and stakeholder theory, meanwhile this current research employed agency, signalling, stakeholder, and communication theories as underpinning theory. The result showed that independent variables in each equation could not explain each dependent variable. This current study also tested the firm performances, however its the uniqueness is to employ earning reinvestment as a new independent variable. A firm might not distribute dividend but they will reinvest their earnings. The size of dividend can reflect the level of risk. Baker and Powell (2012) mentioned that to compensate a high risk investment, the firms that have low disclosure are expected to pay higher dividend.

4.5.1 The benefit of listed companies

Listed companies obtain certain benefits even though they also deal with hindrances. In the Indonesia Stock Exchange guideline book, Capasso et al. (2005), and Zdolsek and Kolar (2013b), they explain that the advantages of public companies are: first, such companies find it easier to get new funding resources from external sources and this may increase their liquidity. Second, they can use these funds for further firm expansion and to increase their competitive advantages. Third, by selling shares the cost of funds will be cheaper than raising funds from debt. Fourth, the owners have opportunities to manage the capital and invest in good portfolios in order to minimise risks. Fifth, they often find it easier to market their products or services to an even wider or even

international scope. Sixth, it is easier for them to access banks to get another source of funds, since they sell shares on the stock exchange market, such companies are more transparent and banks can easily collect data and information related to company performance. Moreover, listed companies can access funds by issuing short term or stock market by issuing long term bonds. By getting more funds listed companies find it easier to arrange mergers or acquisitions of other firms. Merger is a process which unites companies with other companies, while acquisition is a takeover process or the purchase of another company. Those processes are often used for the purpose of accelerating the development of business and boosting firms' scale. Furthermore, listed companies are able to invite their partners such as customers or suppliers to be the potential shareholders; therefore, they can develop companies together in the future. In addition, as listed companies, they are expected to be more professional and have a good operational management in order to achieve the best performance; hence, they are able to offer high earnings to their shareholders. By becoming a public company, each company is able to obtain a valuation of its own value. When they have a good financial performance, it will have the impact of boosting the stock price, creating a good image and prestige, and finally it will increase the value of the company

4.5.2 The hindrances of listed and unlisted companies

On the other hand, listing on the stock exchange market is a complex process as well as an expensive one. The weaknesses of listed companies are: first, listed companies are obliged to make periodical reports to the regulators while facing high pressure from regulators such as the Capital Market Supervisory Agency. Second, the drawbacks

becoming a listed firm are adverse selection, administrative expenses and fees, loss of confidentiality (Pagano, Panetta, & Zingales, 1998). Because they are open companies they have to be transparent in showing their performance; hence their competitors have easy access to their data and management strategies. Third, listed companies are required to maintain their relationship with investors by giving mandatorily progress reports in a timely, accurate and transparent manner.

Capasso, Rossi, and Simonetti (2005) asserted that public companies grow faster than private companies, but tend to be lower in their leverage ratio, and hold fewer tangible assets. Moreover, listed companies tend to deal with more agency problems between managers and stakeholders than unlisted companies. In addition, listed companies obtain funding sources more easily and are more profitable than unlisted companies.

Table 4.2 The advantages and weaknesses of listed companies

Advantages	Weaknesses
Ease of obtaining external funds for firm's growth by selling stock	Must register, adhere to processes, and pay expensive fees
More transparent in reporting its performance, hence wider and easier access to market their products and services	Because companies are obligated to report their performance transparently, their competitors can easily read their data, management and strategies
Has more stakeholders (such as investors, suppliers, customers, regulators)	Deal with agency problem
Boosting firm value	
Less cost of funds, less dependence on loans	
	Highly monitored and scrutinised by public, shareholders, regulators, media coverage
Greater opportunities to merge or acquire other companies	
More professional management due to being subject to monitoring and necessity to give high profit or dividends	

Source: Adapted from Capasso et al. (2005); Zdolsek and Kolar (2013b)

Table 4.3 The differences between listed and unlisted companies

Listed firms	Unlisted firms
	Are affected by asymmetric information
Are easier to get funds by selling shares or issuing bonds	Have fewer opportunities for raising funds (have a financial constraint)
Financial source : internal and external	Depend on internal sources
Adhere to the capital market and financial supervisory regulations	Adhere to financial supervisory regulations
Grow faster and are lower in leverage	Higher leverage
Higher agency problem	Fewer agency problem
Higher liquidity	Have more problems with liquidity
Have more investors and stakeholders	Fewer stakeholders and investors
Easier access to banks for raising debts	
Highly monitored, scrutinised and monitored by public, shareholders, regulators and even media coverage	
Higher firm value, good image and prestige	
Greater opportunities for merger or acquisition of other companies.	

Source: Adapted from Capasso et al. (2005) ; Zdolsek and Kolar (2013b)

4.6 The Differences between Islamic and Non-Islamic Banks

This chapter has five parts and explains the following concepts: shariah rules in transactions; contracts in Islamic banks; the basic law of a shariah capital market; and comparison between Islamic and non-Islamic banks.

4.6.1 Shariah rules in transactions

An Islamic bank is a bank which conducts its business in accordance with Islamic law to follow the Qur'an's rules. Lewis (2001) asserted that in order to comply with sharia, Islamic banks must follow five rules in each transaction. First is riba, second is halal, third is maysir/gharar (gambling), fourth is zakat, finally an Islamic banks has to be monitored by a sharia supervisory board. Each religious feature will be explained in the following text.

First, El-Gamal (2000) stated that Islamic banks are not allowed to employ interest (riba or usury) in any transaction. In addition, Al-Baluchi (2006, p. 52) mentioned that riba is "the addition in the amount of the principal of a loan at a rate decided depending upon the risk, duration, and amount of the loan". Islamic banks are not allowed to give fixed interest to depositors and to take loan interest from borrowers. Moreover, according to the stipulations of the law Republic of Indonesia number 21 in 2008 about Islamic banking, "usury is the addition of illegal income (vanity), among others, in the transaction exchange of goods that are of the same kind of quality, quantity and time of delivery (Fadl) or in borrowing and lending transactions which require the Customer Receiver Facility to return the funds received that exceeds the principal because of the passage of time (nasi'ah)" (author's translation).

On the other hand, conventional banks employ a fixed rate return of interest in both lending and funding transactions. Interest is decided in advance by the bank without considering whether borrowers earn a profit or loss. Moreover, Usmani (1998) mentioned that banks will charge a penalty to the debtors if they default in payment of their debts. Employing interest in the business transaction could exploit poor borrowers and make depositors wealthier. When the borrowers (mudarib) lose, they have to pay their debts even the debt might increase because they must pay charges due to late payment. While the depositors, (rabbulmaal) will receive fixed interest without doing anything and do not have to face risks. It is allowed to get a rate of return fixed in advanced. In addition, Khan and Mirakhor (1989) asserted that a trade or business deals with risk (for example loss or low return), nevertheless in conventional banks, the interest is fixed and earnings can be calculated in advance.

Second, Islamic banks are strictly not allowed to invest or finance activities in the 'haram' goods and businesses; their investment must be in halal (lawful/legal/permitted) business activities. 'Haram' describes business activities that are forbidden or unlawful such as investment in the pork meat business, beer and cigarette companies. Islamic banks are encouraged to support 'halal' productions in basic things to meet the Muslim community's need, namely foods, clothing, housing, education and health (Hassan and Lewis, 2007).

Third, Islamic finance cannot accept transactions with gambling (maysir). According to the Bank of Indonesia regulation number 7/46/PBI/2005 in explanation of article 2, paragraph 3 mentions that 'maysir' is a transaction that contains elements of gambling or highly speculative investment. 'Maysir' describes transactions which are undertaken in an uncertain situation and are speculative; for example, foreign exchange trading. It is categorised as gambling because the owner of the funds gives some money to the agent to make a profit without buying and selling currency in real transactions, and no goods are transacted. This transaction is therefore categorized as gambling and unlawful. Nevertheless, a spot transaction in foreign exchange is allowed because it is a transaction of purchase and sale of foreign exchange with delivery at the time (over the counter) or the settlement within two days. It is permissible, because the transaction is in cash, while the two days are considered to be the settlement process that cannot be avoided as an international transaction.

Furthermore, Islamic banks are also not allowed to conduct 'gharar' transactions. 'Gharar' describes transactions in which the object is not clear / real, not owned, is unknown or cannot be delivered when the transaction has been completed (Kiong, 2014). One example is short selling, whereby investors sell shares without actually owning the

shares at the time of the sale. In addition, 'Gharar' according to El-Gamal (2000) is risk or uncertainty. .

Fourth, Lewis (2001) stated that in Islam people cannot exploit others, so in order to distribute wealth from wealthy to the needy or less fortunate and for purifying wealth; they must pay zakat as a compulsory levy. This zakat is also applied to the bank's capital, the reserve, and the profit. Islamic banks can collect and distribute zakat to the needy.

Finally, in order to assure that an Islamic bank's operations and activities comply with sharia law, they must have a Sharia Supervisory Board/ Committee. The supervisory committee is an independent board and should be composed of members who are not only qualified and expert in fatwa (religious rulings) but also have knowledge of economics and finance, due to their responsibility to decide whether products, processes, and systems in the Islamic bank obey Islamic law.

4.6.2 Contracts in Islamic banks

Some contracts are applied in Islamic banks as a substitute for charging interest. Hassan and Lewis (2007) mentioned that Islamic banks employ 'wadhiah', profit loss sharing (mudarabah), joint venture (musyarakah), sales/mark up mode (murabaha), and 'ijarah' in their transactions. There are two kinds on 'wadhiah'. First, wadhiah al amanah (act to trust /custody or safekeeping) is a contract under which a bank undertakes to safely keep the customer's property, and the bank is not allowed to use that property, but the bank does not refund in the of case loss or damage. Second, 'wadhiah al dammanah' is a contract which allows the bank to utilise the depositor's funds and guarantees the

depositor's funds intact, and in addition the bank is permitted to give a gift depending on the management's decision, without a contract in advance (Hassan and Lewis, 2007).

The profit and loss sharing (PLS) concept for banking was established for the first time in Egypt in 1963 by Ahmed El Najjar. Chong and Liu (2009) explained that the first commercial bank that applied saving deposit based on profit sharing was Nasir Social bank in 1971, and after that Islamic banks grew rapidly worldwide and were established in more than 50 countries, including Indonesia.

Ariffin (2005) mentioned that the PLS concept can be done either 'mudarabah' or 'musyaraka' contract. 'Mudarabah' is a contract between an investor (rabbulmaal) with entrepreneurs (mudarib) employing a PLS transaction. If a bank (mudarib), as a fund manager, receives funds from depositors, the bank manages the funds and obtains a profit or loss then the bank will share the profit or loss with depositors/investors (rabbulmaal). On the other side, a bank (rabbulmaal) provides capital to finance the borrowers/entrepreneurs (mudarib)'s business, then the 'mudarib' will share the profit or loss with the bank (rabbulmaal). The profit or loss will be divided among them based on agreed proportion.

Furthermore, Usmani (1998) mentioned that there are two kinds of mudarabah. First, al-mudarabah al-muqayyadah (restricted mudarabah) is that the rabbul maal invests the funds in the specific halal businesses and then shares the loss or profit. Second, al-mudarabah al-mutlaqah is that the rabbul maal invests the funds in any halal businesses (unrestricted mudarabah) and then share loss or profit between them.

Ariffin (2005) added that another contract with profit or loss sharing is musharaka (joint venture/equity partnership). A bank can collaborate with other partners to share expertise or capital in varying proportions in a long term investment project. Moreover, each party will have representatives on a board of directors for managing the business. They will share loss or profit depending on an agreement based on the portion of capital contributions before the business materialised.

Sources of funds in Islamic banks comprise: current account with wadiah contract; savings account; time deposit account; restricted investment account; and unrestricted investment account with mudarabah contract (figure 4-2). For comparison, the sources of funds of conventional banks are: current account, savings account and time deposit based on interest.

Hassan and Lewis (2007) mentioned that in a mark-up (cost plus financing) scheme (murabaha), a bank will buy assets or goods which are needed by a client from a third party. The bank then sells the assets/goods plus mark up to the client and the client pays in instalments. When the client defaults or delays the payment of the instalments, the price of goods/assets and the mark-up will not increase. There are three kinds of murabaha: first, salam is a scheme of murabaha for agriculture financing. Second, istisnaa is a scheme for financing constructions and manufacturing projects. Third, bai bi-thaminajil (deferred payment financing) is a scheme under which the bank buys the goods that the client needs, such as a house, and the bank sells it to the client. The client is permitted to pay by deferring payment or as a lump sum.

Non-Islamic banks (conventional banks) are not allowed to do leasing, which involves a bank (lessor) buying a property or equipment that the client (lessee) needs and which the bank leases to the client. Nevertheless, Islamic banks are permitted to offer leasing contracts (Ijarah). Ijarah is a contract whereby the lessee can rent tangible properties such as a building or vehicles for a period of time but the lessee also has an option to purchase it without interest (operating Ijarah) at the end of the contract (Hassan and Lewis, 2007).

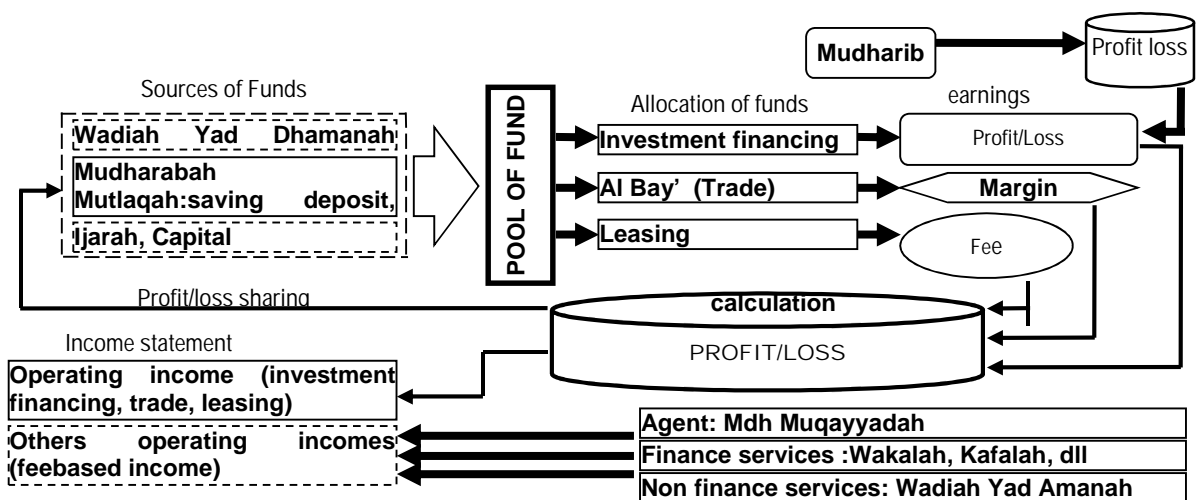

Source: Ascarya (2006, p. 32)

Figure 4-2 Islamic banks' sources of funds and allocation of funds

Figure 4-2 explains the sources of funds and how these funds can be distributed. Sources of funds contain current account deposit with wadiah yaddhamanah contract; saving and time deposit with mudharabah mutlawah contract, capital and ijarah. Those funds will be allocated for investment financing, trade financing with al bay contract, and leasing.

Investment financing involves lending funds from a bank (rabiul maal) to (mudharib) as entrepreneurs who have prospective business under a profit and loss sharing contract. When mudharib earns profit or suffers a loss, they will share the profit or loss with the bank as mentioned in the distribution contract before doing the business. Another allocation of funds is for trading. The banks buy assets that the client needs, and then sell the assets with mark up or margin by murabahah contract. The client pays in instalments. The other possible allocation of funds is leasing. The Islamic bank as the leaser leases the tangible assets and the client (lessee) pays the rent plus administration fee.

From those transactions, the Islamic bank receives profit from sharing contract, margin and fee as their earnings. The profit will be shared to the investors who invested their funds in the wadiah contract and mudarabah contract.

The profit will be posted in the income statement as the operating income. As the Islamic banks offer financial services such as an agent for investing funds in certain businesses, object and time with mudarabah muqayyadah; remittance or transfer money by wakalah contract; issues a guarantee bank and Letter of Credit by kafalah contract; foreign exchange money by sharf contract. Another non-financial service is safe deposit box with wadiah yadamanah. From those services, the Islamic bank receives a fee and it will be posted as others operating income which will not be shared with the investors.

4.6.3 The Basic Law of Sharia Capital Market

Related to activities in the stock market, in general, the activities of Islamic Capital Market do not have differences with conventional capital markets, but there are some special

characteristics of the Islamic Capital Market, namely products and transaction mechanisms which are not contrary to the principles of sharia.

The activities in the capital market with sharia principles also become a part of the capital market system which refers to Law No. 8 of 1995 concerning the Capital Market. Some special rules are related to the Islamic capital market such as Rule Number II.K.1 concerning Criteria and Publishing List of Islamic Securities, Rule Number IX.A.13 concerning Islamic Securities Issuance, and Rule Number IX.A.14 about contracts in the issuance of Islamic securities.

Some Islamic products in the capital market are: first, sharia stocks. Second, sukuk (Islamic bonds). Third, sharia mutual funds. Sharia stock is an ownership of equity in a company and adheres to sharia law. The sharia stock traded in capital market are not allowed to contain a gambling; trading with non-deliverance of goods or services; trading with counterfeit offering/demand; trading with conventional financial institutions such as banks, leasing companies, insurance companies; trading that contains gambling (maisyr) and uncertainty (gharar); trading with companies that produce any haram products and services that stated by National Sharia Board; and dealing with bribes.

According to the Indonesian Ulama Council, Fatwa Number 32 / DSN-MUI / IX / 2002, sukuk are long-term securities based on sharia principles issued by the providers of Islamic bonds to the holders of the bonds. Sukuk requires the issuers to pay profit to the holders of Islamic bonds based on a profit sharing margin / fee, and repay the bond at maturity. Sukuk is issued based on underlying assets, while a bond in the conventional term is categorized as a debt.

Sharia mutual funds, according to Indonesian Ulama Council Fatwa number 20/DSN-MUI/IV/2001 are mutual funds operating in accordance with the provisions and principles of Islamic Shariah, either in the form of a contract between the investor as the owner of the funds (sahib almal / rabb al mal) and the investment manager as representative of sahib al-mal, or between the investment manager as representative of sahib al-mal and investment users. The contract between the investors and the Investment Manager is wakalah, while the contract between the Investment Manager and the investment users are mudaraba.

4.6.4 The comparison between Islamic and non-Islamic banks

Related to their operations, products and services, Islamic banks have to comply with sharia law, which results in Islamic banks having more complex transactions than non-Islamic banks. In doing so, Islamic banks incur higher monitoring and screening costs leading to less efficiency (Beck, Demirguc-Kunt, & Merrouche, 2010). However, Islamic banks are not allowed to do business and have transactions in risky trading activities, therefore Islamic banks are more stable than non-Islamic banks.

When the crisis happened in 2008, Islamic banks showed a better performance in capital asset ratio and had a higher liquidity reserve compared to non-Islamic banks. Moreover, Beck, Demirgüç-Kunt, & Merrouche (2010) found that Islamic banks had a lower finance to deposit ratio than non-Islamic banks. Moreover, Parashar and Venkatesh (2010) asserted that in the period before the crisis (2006-2007) and during the crisis (2008-2009), overall Islamic banks had higher capital ratio, profitability, and equity than conventional banks.

One of the concepts of Islamic banks is that risk is shared between investors or depositors with borrowers or entrepreneurs and it is seen to be fair: on the other hand conventional banks just benefit one party and harm others. Due to Islamic banks employing PLS, asymmetric information could appear in the transaction between shahibul maal and mudarib. Each party is encouraged to be honest in doing business hence transparency in the transactions and operations are crucial. In addition, investors (shahibul maal) and Sharia Supervisory Board/Committee closely monitor and screen profit and loss sharing concepts that need fairness and transparency in contributing profit, therefore Islamic banks have fewer agency problems and moral hazards.

Baydoun and Willetts (2000) mentioned that there are two crucial kinds of financial reports for companies that are operated based on Islamic laws compared with non-Islamic companies. These reports are necessary and must be in addition to the normal reports: the first important thing is that Islamic banks must make full disclosure regarding the public benefit (such as charity donations – zakat), which requires fairness and transparency in Islamic operations. Furthermore, an accountability report is the second priority. In addition, Ariffin (2005) asserted that Islamic banks are required by supervisors to be transparent about risk, and transparency in Islamic banks is more crucial compared to conventional banks due to Islamic banks employing profit and loss sharing contracts. He also mentioned that Islamic banks are still lacking in terms of the transparency with which they release risk information, meaning that shareholders are not properly able to monitor the banks' risk profile.

Regarding risks, Zaidi (2003) stated that Islamic banks and conventional banks deal with the same risks, namely credit, market, liquidity, operational, strategic and reputation risk.

Nevertheless, Islamic banks are often supposed to face additional risks that are not faced by conventional banks, because the laws they operate under entail more risk.

Islamic and non-Islamic banks have state legal frameworks, but Islamic banks have shariah legal. When two of frameworks are combined, it could make a new legal framework. Non-Islamic banks must obey laws and regulations without concerning Islamic law while Islamic banks must adhere laws and regulations and comply with Islamic law.

Banking with dual window system will be in the middle of those frameworks. Bank with dual window is under management of conventional bank (non-Islamic bank), but they operate based on Islamic system. In other words, bank with dual window is a shariah bank operates side by side with non-Islamic bank. In order to accommodate customers' need who want sharia services but still do not want to leave conventional services, the Bank of Indonesia issued a regulation (law number 21/2008) that allowed conventional bank open or have shariah branches.

The consequence of dual windows is bank might be subject to interest rate risk, and their funds could mix with non-Islamic bank's funds which operate with interest. Along with that, regulations and law are really needed in order to make their operation and contract will not break the shariah law. Although structurally still a part of non-Islamic banks, operationally it must has own rules that are tailored to the sharia law.

For establishing a new sharia bank, conventional bank, sharia business unit (SBU), a rural bank or a branch of bank, a permit is required from the Financial Services Authority (FSA). The role of Bank of Indonesia (BI) as a regulator and supervisor of the banks in

Indonesia has shifted to the FSA since 2014. Meanwhile, the BI has one single objective that is to achieve and maintain the stability of Rupiah value. One of the main roles of the BI is to encourage the maintenance of the stability of the financial system through the macro prudential regulation and supervision. An example of macro prudential instruments is an obligation for banks to provide a minimum reserve.

Each bank (Islamic and non-Islamic banks) has to keep 8% of their money in the BI account as a minimum reserve in order to meet the creditors' withdrawal. The rest of money in non-Islamic banks can be distributed as loan that can create money (fiat money and electronic money) that employs interest. Meanwhile, Islamic banks cannot create money, because sharia banks employ 100% reserve banking system. Islamic banks are allowed to distribute their money as much as they have in the deposit (Ascarya (2006) in Gustiani, Ascarya, and Effendi (2010)).

When a bank needs to get money in short term for liquidity, there is interbank money market for non-Islamic and Islamic banks. Interbank money market is the activity of lending and borrowing funds in Rupiah between the conventional with other conventional banks, without the use of money market as underlying/collateral such as money market securities with interest. While for Islamic banks, the transaction is based on Islamic law and it is traded by Sharia repurchase agreement. The instruments that can be sold are Interbank Mudharabah Investment Certificate (the BI regulation number 2/8/PBI/2000 about sharia Interbank money market) and Commodity Certificate based on Shariah Principles issued by banks with maximum period is 90 days.

Table 4.4 Summary of the differences between Islamic banks and non-Islamic banks

Islamic banks	Non-Islamic banks
Operations and transactions based on sharia/Islamic law	No religious restrictions
The transactions, funding and lending are not allowed to employ interest (usury/riba), but are based on profit and loss sharing (mudarabah), a joint venture (musyarakah) and mark up sales (murabaha)	Deposits and loans based on interest
Must have Sharia supervisory board/committee	Do not have religious supervision
The investments must be halal (lawful) businesses	Do not consider halal or haram (unlawful) businesses
The bank not only pay out zakat, but also collect and distribute zakat to the needy	Do not deal with zakat
The relationship is as partner, investors and trader, buyer and seller	The relationship is debtors and depositors
<p>Source of funds :</p> <p>The bank does not guarantee all deposits, except demand deposit / current account based on wadiah principle.</p> <p>Savings accounts and time deposits based on profit and loss sharing with mudarabah contract will not be guaranteed by bank.</p> <p>Unrestricted investment account based on mudarabah contract</p> <p>Restricted investment account based on mudarabah contract</p>	Banks guarantee all deposits
Banks and investors of time deposit and saving deposit based on mudarabah concept have to share the profit and loss portion in their transactions.	Conventional banks have to guarantee all deposits
The transactions between Banks and entrepreneurs are based on mudarabah concepts with profit and loss sharing. Islamic banks will not charge when the borrowers delay repayment	Debtors have to repay debts even though they make a loss, and will be charged (penalised) when debtors cannot pay their installments on time

Islamic Banks	Non-Islamic Banks
Transactions in the money market and capital market must adhere to sharia law	Banks find it easier to do financial transactions in the money market and capital market either based on sharia or conventional system.
All transactions must be based on underlying tangible assets or inventories	The transactions could be done without real underlying assets, mostly based on money
Less agency problem and moral hazard	Higher agency problem
Employs profit and loss sharing (sharing risks) based on proportionality	Giving benefit for one party, harm for others and unfair risks.
Fairness and greater transparency are very important due to a profit and loss scheme	One party makes a profit, another party makes a loss.
There is a social welfare contract using Qard al Hasanah	
Involves more risk when banks give loan to mudarib, not only defaults in repayment leading to decreases in profit, but also writing off the debts. Banks give time until the borrowers are able to repay	Less risk when debtors are not able to repay debt, banks will charge them and employ compound interest
Have same risks as non-Islamic banks, however Islamic bank deals with "Islamic laws risk"	Deal with market risk, credit risk, operational risk, strategic risk, reputational risk.
For liquidity problem, bank can issue Interbank Mudharabah Investment Certificate or Commodity Certificate based on Shariah Principles	Banks can issue money market securities if they have liquidity problem.
cannot make money creation	Able to make money creation

Source: Adopted from Bakar (2010), Ariffin (2005); Beck, Demirgüç-Kunt, and Merrouche (2010); Usmani (1998)

Table 4.5 Summary of Listed banks, Unlisted banks, Islamic banks and Non-Islamic banks

	Listed banks	Unlisted banks
Islamic banks	All transactions obey Islamic law : free of riba, no gharar and maysir,	All transactions obey Islamic law
	Able to sell Islamic Securities /bonds	Does not sell securities
	Are not allowed to buy non-Islamic securities/bonds : shares, sukuk (Islamic bonds), mutual funds	Are not allowed to buy non-Islamic securities / bonds

Islamic banks	Listed banks	Unlisted banks
	Subject to Indonesia Capital Market Supervisory Agency and Financial Institution regulations; Bank of Indonesia regulations; Financial Services Authority regulation	Subject to Bank of Indonesia regulations; Financial Services Authority regulations
	Must have a shariah supervisory board	Must have a shariah supervisory board
	Employ PLS	Employ PLS
	Fewer agency problems and moral hazards	
	All transactions must be based on underlying tangible assets	All transactions must be based on underlying tangible assets
	The relationship is as partner, investors and trader, buyer and seller	The relationship is as partner, investors and trader, buyer and seller
	Transaction in the money market and capital market must adhere to sharia law	
	Transactions are not allowed to employ interest (usury/riba), but are based on profit and loss sharing (mudarabah), a joint venture (musyarakah) and mark up sales (murabaha)	Transactions are not allowed to employ interest (usury/riba), but are based on profit and loss sharing (mudarabah), a joint venture (musyarakah) and mark up sales (murabaha)
	Funding and lending are interest free	Funding and lending are interest free
	Not only deal with market risks, operational risks, credit risks, strategic risks, reputational risk but also deal with "shariah law"	Not only deal with market risks, operational risks, credit risks, strategic risks, reputational risk but also deal with "shariah law"
Non-Islamic banks	Subject to Indonesia Capital Market Supervisory Agency and Financial Institution regulations; Bank of Indonesia regulations; Financial Services Authority regulation	Subject to Bank of Indonesia regulations; Financial Services Authority regulations
	Do not have religious supervisory board	Do not have religious supervisory board
	Allowed to buy Islamic and non-Islamic securities	Allowed to buy Islamic and non-Islamic securities
	Do Not Deal with "shariah law"	Do Not Deal with "shariah law"

Source: Adopted from Capasso et al. (2005), Bakar (2010), Ariffin (2005); Beck et al. (2010); Usmani (1998)

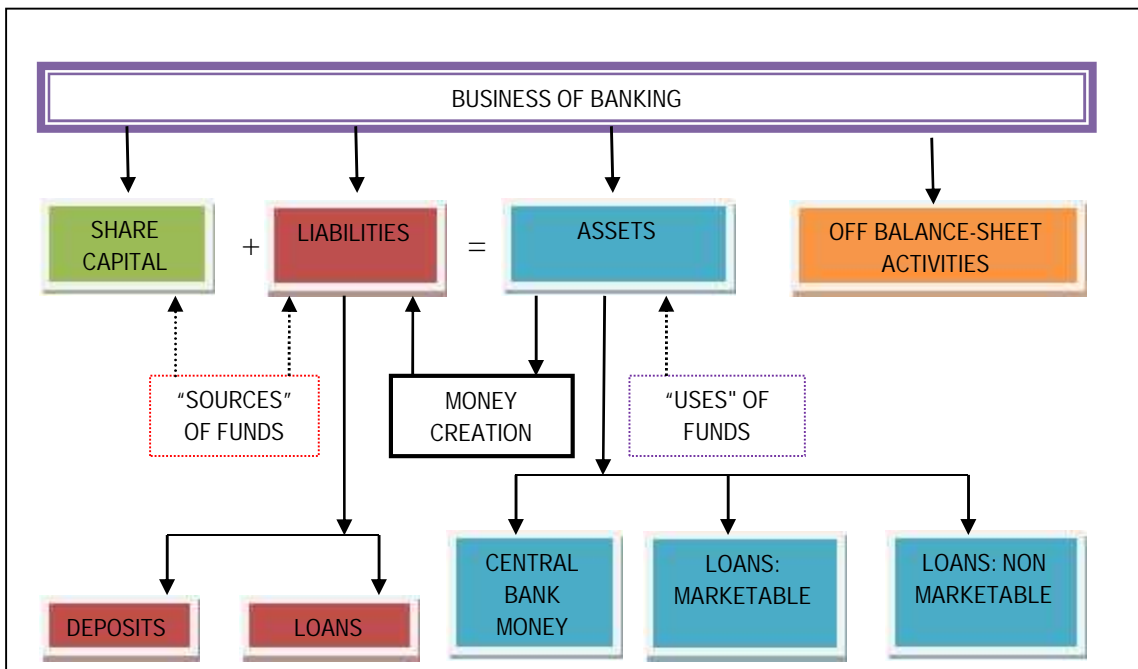

Source: (Faure, 2013, p. 48)

Figure 4-3 The business of banking

CHAPTER 5

RESEARCH METHODOLOGY

5.1 Introduction

It is necessary to decide what methodology and methods will be used in order to answer the research aim, research questions and to test hypotheses, as well as how the data will be collected and how to measure the variables. Along with that, this chapter gives an overview of the research approach and contains seven parts, viz. introduction, research methodology, methods, the population and data periods covered, the dependent and independent variables, validity and reliability test, and it will be summarised by a conclusion.

5.2 Research Methodology

In deciding the research methodology, it should be based on an epistemological point of view. Crotty (1998, p. 3) states that epistemology is “the theory of knowledge embedded in the theoretical perspective and thereby in the methodology”. He also mentioned that “methodology is the strategy, plan of action, processes or design lying behind the choice and use of particular methods and linking the choice and use of methods to desired outcomes”. In addition, Gray et al. (2007, p. 14) mentioned that “research methodology is the study of the research process itself – the principles, procedures, and strategies for gathering information, analysing it, and interpreting it”.

In social science research methodologies are categorised into three general formats, namely quantitative, qualitative and mixed. Quantitative research methodology according to Gray et al., (2007, p.61) “emphasizes ordinal measures and number” but in particular, a “quantitative research methodology attempts to establish formal relationships between

related variables. It is mostly guided by positivist philosophy". A positivist philosophy believes that social phenomena can be explained by numbers which represent such conditions. Moreover, Creswell (2014) mentioned that quantitative research is a research by collecting numerical data, identifying variables, predicting hypotheses, and employing statistics tool for analysing hypotheses.

Qualitative research is "an approach for exploring and understanding the meaning individuals or groups ascribe to a social or human problem" (Creswell, 2009, p.4). He also mentioned that mixed methods research is an approach which use both quantitative and qualitative data.

Research Methodology of this Thesis

This research examines the hypothesis of the determinants of risk disclosure; it also examines the value relevance of the firm value of listed and unlisted banks, and Islamic and non-Islamic banks. The data related to determinants, firm value and risk disclosure are collected from annual reports, such as financial reports and ratios.

The annual reports were downloaded from each bank's website, the Bank of Indonesia and the Indonesia Stock Exchange's website. According to Hakim (1982), data that are collected from literature reviews, publications (such as: journals, newspapers), books, and websites are categorised as secondary data.

The benefits of secondary data according to (Ghauri & Gronhaug, 2005); Churchill (2010) are: first, the data already exists. Second, it is relatively easy to collect by searching the internet, scanning newspapers, or by reading reports published by companies,

governments, stock exchanges, public databases, or related departments. Third, the researcher does not gather data directly in the field because it has already been collected by others. Fourth, the researcher can use the data in a variety of forms. Fifth, it is more efficient and less expensive. Six, data can represent a national or international scope. Finally, the data is easy to collect over a long time period and it is easy to process with software. Nevertheless, secondary data has weaknesses, first, the data are already given, meaning that they might be either not appropriate or not as detailed as the researcher needs or proposes. Along with that it should be tested for validity. Second, certain kinds of research require the newest data while secondary data is typically from a previous time.

Annual reports are the most crucial sources of data in this research. The advantages of using annual reports include that they are regularly issued by banks as a mandatory rule from the Bank of Indonesia and the Indonesia Stock Exchange. Annual reports reflect historical management activities and important information. Furthermore, annual reports are able to explain company performance in both quantitative and qualitative ways and provide more detail, including pictures, graph and tables. Finally, related to the research objective, annual reports are the best sources to measure risk disclosure by counting sentences with keywords. In addition, Aljifri (2008) asserted that reporting firm performance through a website or online has some advantages. First at all, an online annual report is more complete and wide-ranging than other forms. Second, it gives firms the opportunity to report their performance more flexibly; an issue related to the complexity of the report, as online they may want to explore more without the limitation of paper based presentation. Third, it is more efficient, uses less paper and takes up

less space. In addition, it can be read by users around the world any time, who can rapidly and easily search and download for any purposes. Finally, the firms are able to make the reports more interesting by showing pictures, tables, or animation.

This study did not employ the online information from the bank's website because each bank has different model of website and the information itself could not be converted into text. While the research question is to measure the extent of risk disclosure, hence employing annual report in pdf format by downloading from bank's website is more proper to be converted into text and easy to be tested by QSRN6.

Based on the research aim, which is to analyse the association between the determinants, namely: bank size: liquidity: profitability: leverage: and earnings reinvestment, with risk disclosure and firm value, in addition to the value relevance of risk disclosure, all of this requires numerical data from a bank's financial report, which means this research adopts a quantitative methodology and thus tends to a philosophical position of positivism. Moreover, this study needs data covering a long time period (2008 to 2012) in order to provide valid generalisable results.

Communication theory suggested that a good communication is when the sender can send the information through an appropriate channel in order to make receiver understand what the sender has sent. Corroborating with communication theory, signalling theory mentions that one party (sender) deliver a signal as an information to the other party (receiver), nevertheless asymmetric information problem can interfere in this process. Moreover, agency theory asserted that there is a correlation between principals and agents, but asymmetric information can appear between them.

Disclosure of the annual report can reduce the agency problem. In other way, the principal need firm performance in more detail in the annual report from the agent before they make financial decision, and it will be value relevant if the information are useful for stakeholders. In this research, banks send their performance information as the signal to the stakeholders through annual report. By using annual reports, it can be measured how the extent of the risk disclosure can be quantified, what is the determinants and the factors affect a bank's decision to disclose the risk and whether risk disclosure is value relevant for stakeholders in Indonesian banking sector. In order to answer the research questions, it should be more properly tested by quantitative methodology rather than qualitative methodology, because it is easier to get the data from annual report and the result can be generalised. In addition, the data can be tested by using statistical method and even comparing between listed and unlisted, Islamic and non-Islamic banks.

Furthermore, agency theory is a neo classical or positive theory that experimentally test its implications using quantitative methods. Signalling theory similarly adopt a quantitative approach. Their implication on measurement of risk disclosure are as follows:

1. The appropriate approach within the literature has used quantitative methodology such as Hassan et al, (2009); Uyar and Kilic (2012). Hence, the reason why this research employs a positivist approach is because it follows the approach of previous research that has been done by quantitative methods.
2. The theories itself, agency and signalling theory, have positive implications which testable that follow the quantitative approach. Agency theory that has discussed in chapter 3 has positive implication which are tested through quantitative

methods. In positive theory empirically has tested in the literature. Hence, this study has the most appropriate approach for study in Indonesia.

3. A justification in using quantitative methodology because this study stressed measuring risk keywords and sentences in the annual reports in order to test research hypotheses. Along with that quantitative approach is required.

The Ontology of Risk

There is an implicit assumption in the literature that the measurement of risk as reported by a firm is targeting. Ryan (2007) mentioned that theory at least would suggest that the concept of risk is the predominant concern of external investors. The reality of risk as reported in the financial statement is one of a series of constructs which are believed to have some relationship with underlying notions or concepts of risk relevant to investors.

The risk terms employed in this study have been adopted as broadly classified within the literature. However, it is not clear that the accounting constructs used by financial reports, reflects the reality of risk from an investor's perspective. Ontologically, there appears to be a distinction in the literature between a firm's socially constructed reality and a more realistic perspective contained within the statistical measures of asset volatility. Previous research has tended to be based upon the former and the results need to be interpreted accordingly.

5.3 Research Methods

Methods, according to Crotty (1998, p. 3) are "the techniques or procedures used to gather and analyze data related to some research questions or hypothesis". In addition, Williams (2007, pp.66-67) declared that "a quantitative research method involve a

numeric or statistical approach to research design. As a result, data is used to objectively measure reality” while a “qualitative method involves purposeful use for describing, explaining and interpreting collected data“. In other words, quantitative method is a method which employs statistical data and makes the data into tables and or graphs. After gathering data and all relevant information on mandatory and voluntary risk disclosure, the data will be examined to establish the relationship between variables, using statistical tools to analyse the result.

In order to quantify the extent of risk disclosure in the annual report over the period from 2008 to 2012, this study employs a technique of counting the Indonesian risk keyword divided by the number of Indonesian sentences. Due to some annual reports being reported in dual languages, English and Indonesian, the total sentences in dual languages was divided by two. Kravet and Muslu (2013) asserted that risk disclosure can be reflected in the total number of sentences with at least one risk keyword.

Measuring risk disclosure by counting the Indonesian risk keyword divided by the number of Indonesian sentences has several advantages. First of all, by counting the sentences, multiple counting of the same keywords is avoided. A broader perspective was adopted by Milne and Adler (1999), who argued that counting sentences is better than just merely counting keywords, because sentences are more trustworthy and meaningful than words in describing a particular purpose. Moreover, the practicalities of disclosure can differ from sentence to sentence. In a study conducted by Haniffa and Cooke (2005) it was shown that measuring risk disclosure by counting sentences is better than counting words or pages, because a sentence is more objective in their interpretation of the connotation and meaning. An annual report may have many pages, but it might just be

full of pictures, graphs or numbers and offer little explanation. Hopkins (1996b) also explained that using sentences for explaining firm information is easier to read and interpret for users.

In order to boost trustworthiness, and also to aid stakeholders to assess the firm's condition and strategies, companies have to provide comprehensive information. The annual report is a prime medium for presenting information from the company to users, consisting as it does of a finance summary, analysis and report by management, as well as financial reports. In addition, an annual report communicates the financial condition and other conditions (non-financial) for the shareholders, creditors, stakeholders and potential shareholders to show the firm's effectiveness in achieving its goals and the corporate responsibility report of the organisation (Healy & Palepu, 2001). As sources of information, financial reports are needed by users for consideration in the making of financial decisions.

5.4 The population and data periods covered

The population of this research is focused on listed and unlisted banks, Islamic and non-Islamic banks in Indonesia, which released annual reports over the years 2008 to 2012. The choice of the period covered by the data used in this research was based on a number of reasons, first since 2008 Indonesian banks have had to manage their risk based on Basel II, and since 2009 all banks' managers and staff have been required to have a risk management certificate, hence they had better knowledge in managing and reporting risk. In addition, best practice of IFRS (International Financial Reporting Standards) in Indonesia which was introduced in 2012, forced banks to publish their risk performance in more detail than they has in previous reports. This meant that by starting

the application of IFRS in 2012, banks are likely to have been more transparent in reporting their performance starting in 2013.

There are 120 banks in Indonesia: based on the listing on the Indonesia stock exchange there are 32 listed banks and 88 unlisted banks, while in terms of banks based on sharia principles, there are 11 Islamic banks and 109 non-Islamic banks. One of them, Muamalat, an Islamic bank, is categorised as an unlisted bank in this study because it was not trading shares in ISEM, but rather sold Subordinated Sukuk Mudharabah and subordinated sharia bonds; hence the movement of share price was not available.

5.5 Dependent and independent variables

Based on the research aim, which is to analyse the association between the determinants and value relevance of risk disclosure in the Indonesian banking sector, the research will discuss the independent variables which might have a relationship with the dependent variables and whether risk disclosure has value for users. Along with that, this part explains dependent and independent variables and their measurement. This part also explains how to conduct validity and reliability tests.

5.5.1 Dependent variables

Based on the research questions, this research employs two dependent variables, namely risk disclosure (Y1) and firm value (Y2).

Risk Disclosure (Y1)

Risk disclosure can be measured by a range of methods, but no one measurement is perfect and has all the advantages and none of the disadvantages. One of the methods

for measuring risk disclosure is a disclosure index. Cerf (1961) is the first researcher who measured risk disclosure by using a disclosure index with 31 items based on the interview method and scored in four scales. Botosan (1997) employed a disclosure index, whereby the level of risk disclosure was measured by an ordinal weighted scale. The scales were built based on the weighting of information as follows: score two if the information shows quantified disclosure; score one if the information explains disclosure through qualified information, and zero if it does not give any information. They argued that the information in some items is more important and relevant than others items for stakeholders. Moreover, they asserted that quantitative information is more important, useful, and precise, than qualitative information hence quantitative information has the highest score. On the other hand, Beretta and Bozzolan (2004) mentioned that qualitative information is more important than quantitative information.

Numerous studies have attempted to explain the content of disclosure and measure those contents qualitatively and quantitatively. Hopkins (1996b) argued that the extent of high quality disclosure information can potentially be measured by how easily it can be read and interpreted by investors easily. However, due to the difficulty in measuring investors' perception of disclosure quality, researchers commonly use disclosure quantity as a proxy for disclosure quality (Bamber & McMeeking, 2012).

There are many analyses of the quantity of corporate disclosure in different forms, including reviews of the number of words (Hasseldine, 2005). More recent examples of quantity based content analysis studies have counted the number of risk relevant sentences (Linsley & Shrives, 2006). Bamber and McMeeking (2012) explained that

there are four reasons why quantity is preferable: because it is less subjective, simple to measure, efficient, and technical accounting and auditing knowledge is not required.

Hassan et al. (2009) measured levels of disclosure in the Dubai Financial Market by using the Disclosure Index methodology with 45 items of information which were grouped into general risk information (10 items of information); accounting policies (13 items); financial instruments (4 items); derivative hedging (3 items) ; reserves (3 items); segment information (3 items); financial and other risks (9 items). To measure level of disclosure, Greco (2011) employed a content analysis method. Another method to measure level of disclosure used by Hutajulu (2002) was to count the number of standardised text lines with each line having a maximum 72 characters.

Al-janadi, Rahman, and Omar (2012) employed three unweighted levels of voluntary disclosure, namely: level 3 if the report explains qualitative and quantitative information; level 2 if the report exhibits either qualitative or quantitative information; level 1 if the items are not disclosed. They argued that unweighted levels are better than a weighted scale because they perceived that all information in the items was crucial and relevant for stakeholders as they have different needs. Furthermore, Bailey, Karolyi, and Salvac (2005) used dummy variables to count risks disclosure. Albeit this method only emphasizes whether a firm reports risk disclosure items or not, without considering the content of annual reports in more detail and whether it is readable.

Wallace and Naser (1995) attested that disclosure index is a good method and suitable for checking the mandatory items of disclosure, but is not appropriate for checking information within voluntary disclosure. Nevertheless, those methods only calculate

certain points in particular disclosure related to risk information or items, because firms should explain risks in their annual reports due to existing regulations. Furthermore, this method is not able to detect whether the firm explains the risks in more detail or not, the extent of risk information, even the delta in the company's performance in every period. Moreover, Hassan et al. (2009) mentioned that a disclosure index requires judgment in deciding the type and items of information, and more tends to be more subjective.

Another method for measuring risk disclosure is counting the pages of the annual reports. Even though it is very easy and quick, pages might not explain the risk in more detail or may not be able to reflect their performance. Firms may report over many pages, but if these pages just show a lot of pictures, tables or graphs, and there is less in the sentences or less information, therefore the meaning may not be understood clearly by stakeholders, and they could even misunderstand it.

This study does not employ questionnaires or interviews for measuring risk disclosure, because Hassan and Marston (2010) mentioned that if the design of questionnaires is not quite done well or properly, it will impact the interpretation and final result. Moreover, viewing individual reports users of financial information cannot compare the information among banks, or between listed and unlisted banks, or between Islamic and non-Islamic banks. The users also cannot remember what was going on with the banks and comparing over the time 2008-2012.

Kravet and Muslu (2013, p.1094) defined that risk disclosure can be reflected by the total number of sentences with at least one risk-related keyword. The code tags a sentence as risk-related if the sentence includes at least one of the following risk-related keywords

“(where * implies that suffixes are allowed): can/cannot, could, may, might, risk*, uncertain*, likely to, subject to, potential*, vary*/varies, depend*, expos*, fluctuat*, possibl*, susceptible, affect, influenc*, and hedg* “ and compare year-on-year deltas in the level of disclosure”.

This research also refer to Elshandidy et al. (2013, p. 17) who examined risk disclosure by reliability and validity before determining risk words; it means that the list keywords are appropriate to be applied to other researches. The list includes the following words: “risk*, loss*, decline (declined), decrease (decreased), less, low*, fail (failure), threat, verse (versed, reverse, reversed), viable, against, catastrophe (catastrophic), shortage, unable, challenge (challenges), uncertain (uncertainty, uncertainties), gain (gains), chance (chances), increase (increased), peak (peaked), fluctuate*, differ*, diversify*, probable*, and significant*”.

The words with * means include derivatives from the original words.

Hopskins (1996b) argued that the extent of the disclosure of quality information in the sentences can potentially be read and interpreted by investors easily. Previous researchers have employed some quantity methods for measuring risk disclosure. For example, Botosan (1997); Hassan et al. (2009); Khotari et al. (2009); Hussainey et al. (2003); Berreta and Bozzolan, (2004); Abraham and Cox (2007) used content analysis to measure disclosure level, while Gruning (2011) utilised a combination of words, sentences and lines.

More recent examples of quantity based content analysis studies have counted the number of risk relevant sentences (Linsley & Shrives, 2006). Sentences were used to

record those disclosures because of conclusions that sentences are more reliable and valid in cases if the study uses narrative text for counting disclosure of the annual reports (Milne & Adler, 1999). In addition, Lajili and Zeghal (2005) asserted that risk disclosure in the annual report are mainly described through non-financial types of data, which tend to be qualitative and narrative. This is able to provide a clearer description of the extent of disclosure and gives an emphasis in each item that should be informed to stakeholders in order to make them clearly understand the firm's real condition. Finally, by using sentences instead of words for quantifying the quantity risk disclosure, multiple counting of the same risk-related information is avoided

In addition, this study does not count merely the words or lines because according to Ivers (1991) a word is the smallest unit in the sentences, even though it has a meaning it cannot deliver the idea or message. While counting lines could not reflect the meaning of risk disclosure, neither it can deliver the idea or message.

Along with that, risk disclosure, as the first-dependent variable (Y1), is proxy by number of sentences and has at least one of the Indonesian risk keywords divided by total number of Indonesian sentences in the bank's annual reports.

In order to measure risk disclosure this study is aided by software QSR Nudist 6 (Non Numerical Unstructured Data Indexing Searching and Theorizing). The advantages of QSR Nudist6 are that it is easy to use and gives suppleness in importing data for distinctive purposes. It is also easy and faster to make data grouping than manually (Parlalis, 2011). Nevertheless, it has some problems, for example: the annual reports

could not be converted in to text because of being corrupted, blank, or having a password, hence this software cannot process it.

There are some steps to calculate quantity risk disclosure. The first step is to down load the annual reports in PDF from each bank. The second step is to convert each annual report into a text file, and then save it in a separate text file. The next step is to identify words that are associated with risk that are reflected in the sentences in annual reports. Afterwards, put the text files into QSR Nudist6 and run it.

Firm Value (Y2)

The second dependent variable is firm value (Y2). Due to the population in this research being listed and unlisted banks, the firm value will be measured by a different method. For measuring firm value for the listed banks this research will employ Tobin's Q. While firm value for unlisted banks will be measured by the approach of the Black Scholes Merton option pricing model.

a. Measuring firm value for listed banks

Firm value of listed banks will be measured by Tobin's Q because it is able to estimate the success of management. Changes in Tobin's Q ratio provides a measurement of companies' performance over time (Evans & Gentry, 2003).

Chung and Pruitt (1994) stated the ratio of Tobin's Q, as follows:

Tobin's Q = (MVE + PS + DEBT)/TA, where

MVE = product of firm's share price and the number of common stock shares outstanding

PS = liquidating value of the firm's outranging preferred stock

DEBT = value of the firm's short-term liabilities net of its short-term assets plus
book value of the firm's long term debt (current liabilities – current assets) +
(book value of inventories) + long term debt

TA = book value of the total assets

b. Measuring firm value for unlisted banks

The increase of investment activities is shown by the appearance of a number of investment alternatives. One of these investment types is the option. Option is one of the instruments that are classified as a derivative securities stock. Options are called derivatives because they must have underlying securities. There are two kinds of option, namely call and put options. In general, the option can be interpreted as a claim to buy or sell a particular stock that is deliberately created by other investors.

An option is an agreement between two parties, i.e. the writer and the holder. The holder has a right to buy (call option) or to sell (put option) an underlying asset in a specified time and specified price (Ryan, 2007) . A call option entitles shareholders to purchase a number of shares at a specified price at any time before maturity on date, whereas a put option gives the right to the shareholders to sell a number of shares at a specified price at any time before rights are exhausted on a given date. Usually the option is sold by the issuer at a specified price. If the holder sells an underlying asset at a specified time and price to the writer, it means the holder uses the right of "put option". Conversely, if the

holder buys an underlying asset, it means the holder uses the right of a “call option”. If the actual price is less than the exercise price, the holder can use the put option right to get benefit or premium by selling the shares to the writer. On the other hand, if the exercise price is less than the actual price, the holder can keep the shares or buy the shares. It means the holder uses the call option right.

The Black Scholes option pricing valuation model is a model that has been widely used in financial investments. The option value can be measured by the Black Scholes (F. Black, 1976). The Structural Model introduced in Black and Scholes’ seminal paper in 1973 is concerned with options modelling. This model was developed by Merton in 1973 in an adaptation which uses a bankrupt risk model and modified the Black-Scholes model (Merton, 1973) and is now known as the Black-Scholes-Merton (BSM). This model assumes that the stock price variance is a constant, random process in obtaining stock price, stock does not pay dividends, no transaction costs, and a risk-free interest rate. Furthermore, option price is strongly influenced by the stock price, the exercise price, volatility, interest rates, and time (Hull, 2012, p.309).

The reasons for using Black Scholes Merton model for measuring the firm value of unlisted banks

In the seminal paper Black Scholes recognised that the present of limited liability offered a call option underlying assets of the firm. This was extended by Merton subsequent paper. Merton recognised that an equity investor under limited liability was in possession of a put option on the underlying of assets of the business for their term to maturity. The equity investor when combining the implied put option associated with the limited liability

and their long position in the underlying assets of the firm had through put call parity, a call option for the term of liability of the firm. The liabilities represent the exercise, strike price of the implied call option. With this Black Scholes Merton offered a theoretical mechanism for valuing contingent claims in the business and indeed in any area of valuation.

The net present value method of valuation give a spot value on the firm but the Black Scholes model allows one to value the firm where the investor has the ultimate choices whether to remain invested or not in the future. Black Scholes model measures the volatility of the firm's underlying assets on equity.

Equity value is an important number for a business owner to know when selling a business. Firm equity value (E) is total assets (A) minus liabilities (L), and is reflected in share price, and share price will increase when assets are higher than liabilities (Ryan (2007)). It can be shown in the figure 5-1.

The Merton model (1974) shows that not only the value of liability and value of the equity can be measured, but also the probability of loss can be estimated under some assumptions by using a call option of assets. Black (1976) explains that the premium from call or put option is determined by: first, the value of underlying assets; second, volatility of assets; third, the exercise price; fourth the risk free risk; and finally, time to exercise. It can be written as equity value = $f(\text{asset value, asset volatility, value of debt, risk free risk, time to exercise})$. It can be shown that value of firm will increase when assets are higher than liabilities in figure 5. 2.

Asset value is the maximum price that assets are worth to the owners and how much they will be paid for it if the company is sold. Moreover, value of debt or liability is a debt or obligation of the firm currently arising from past events. Furthermore, volatility is a movement of securities value that cannot be predicted accurately. A high volatile security indicates a high risk security.

Problem in the bank is an industry which has high gearing. Equity is a small fraction of the underlying asset value of the bank. In this situation, the bank's limited liability give what we call time value for investors, because in the failure condition, shareholders can walk away with zero liabilities. Therefore, the equity value of the bank can be regarded as call option on the underlying asset of the bank. The BSM call options refer to equity value, while Merton develop bankrupt model implying asset value and volatility of asset. Share price will very reflective the value of a call option on the underlying asset bank in the market value (Ryan, 2007). All in all, it is the simple procedure to measure firm value for unlisted bank by using Black Scholes Merton model.

The steps to measure firm value for unlisted banks

Volatility can be measured by the standard deviation of the continuously generated rates of return on the underlying assets. Time to exercise is a time when the holder uses the right for selling or buying the option. Risk free rate is a security interest that has low risk when there is no inflation. The model of call option based on Black Sholes model as follows:

$$C = N(d1) P_o - N(d2) P e^{-rt} \quad \text{where}$$

$$d1 = \frac{(\ln(P0/Pe) + (r + 0.5 \sigma^2)t)}{\sigma \sqrt{t}}$$

$$d2 = d1 - \sigma \sqrt{t}$$

C = call option value

P0 = current price

Pe = exercise price

t = time to expiry (a trading days calendar 250-252 days) Hull (2009)

r = risk free rate

σ = volatility

N(d1) = normal distribution

d1 = Z score

d2 = a standard deviation (adjusted for time) to the left from the d1 score (Ryan, 2007, p.289).

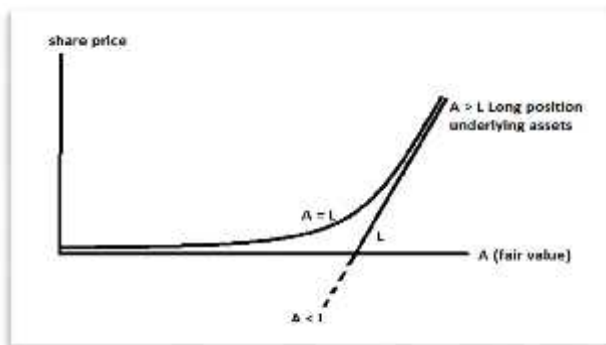

Source: Ryan (2007)

Figure 5-1 The relationship between share price and fair value

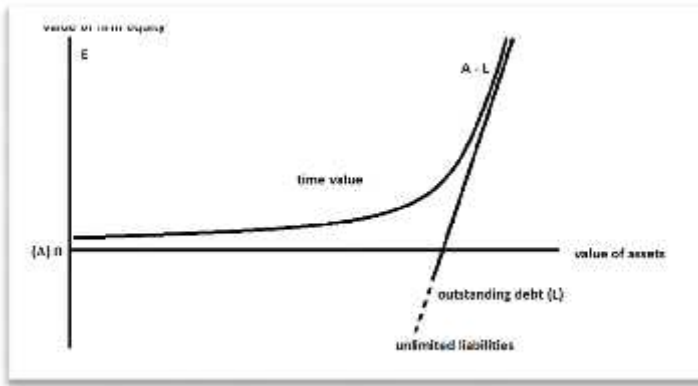

Source: Ryan (2007)

Figure 5-2 The relationship between value of firm and value of assets

A firm value for equity of an unlisted bank can be achieved by using the implied volatility of a listed bank. The proxies can be explained in table 5-1 below:

Table 5.1 The valuation variable

No	Measurement of value of option (C) by Black Scholes model	Measurement for estimating the equity of firm value (E) by Merton model
1	Current price (Po)	Assets value (Ao)
2	Exercise price (Pe)	Total Liabilities (Le)
3	Risk free rate (r)	Risk free rate (r)
4	Time to exercise day (t)	Time to repay liabilities (estimated average term to maturity of firm liabilities) (t)
5	Volatility of shares (e)	Volatility (standard deviation) of asset value (A)
		$E = N(d1) A_0 - N(d2) A e^{-rt}$ where $d1 = \frac{\ln(A_0/Ae) + (r + 0.5 \sigma^2 A)t}{\sigma \sqrt{t}}$ $d2 = d1 - \sigma \sqrt{t}$

In order to achieve an estimated value of equity for the proxy of firm value of unlisted banks, this research will employ two models i.e. The Merton Structural debt Model and Black and Scholes Option Pricing Model. To simplify the calculation of those models, it will be supported by Excel spreadsheet. Three main excels will be used to explain how the firm value can be measured. First, the volatility estimator spread sheet for achieving a number of the volatility of equity. Second, The Merton structural debt model spread sheet will be used for calculating asset volatility of listed banks. Third, the Black and Scholes option pricing model spread sheet will be used for achieving the estimated value of equity for unlisted banks.

The three main steps for calculating the estimated value of equity for the proxy of the firm value of unlisted banks is as follows:

1. Measuring the Annual Volatility of Equity

There are some steps for measuring volatility of equity using a volatility estimator, as shown in excel spreadsheet (Table 5.2). First, put daily share price in the volatility estimator spread sheet, at least 101 days (N), in the cell B7-B107. Second, measure % return by counting = LN (1+ (CPt-CPt-1)/CPt-1. In the excel, the formula is LN (1+ (B7-B8)/B8) and so on. Put the result in cell C7 until C106. Then, calculate the average of % return and put the result in cell G6. Afterwards, calculate (101-n)/sum (D7:D106) times squared of (%return-average daily of %return). Put the results in cell E7 – E106. The next step is measuring daily volatility (weighted) by square root of sum (E7; E106) and put the result in cell G8. Finally, measure annual volatility (weighted), that is squared root of 250 days multiplied daily volatility (weighted). Put the result in cell O8. This

number will be used for the input of volatility equity in the Merton model spread sheet (table 5.3).

Table 5.2 Volatility estimator

The screenshot shows an Excel spreadsheet with the following data table:

daily	Close	%return	Geometric	Moving V	Average V	bin	frequency	likelihood	Average (arithmetic)	Volatility	Average Geometric
1	9E	0.00%	100	0.0000000	1.0000	99	0.932%	2.750%	-6%	4	0.04040404
2	9E	-1.04%	99	0.0000019	0.9896	98	0.932%	2.750%	-5.50%	0	0
3	97	1.04%	98	0.0000023	0.9999	97	2.261%	2.750%	-5.00%	0	0
4	96	1.05%	97	0.0000024	1.0104	96	2.441%	2.750%	-4.50%	0	0
5	95	1.06%	96	0.0000024	1.0211	95	2.373%	2.750%	-4.00%	3	0.03030303
6	94	0.00%	95	0.0000000	1.0211	94	2.335%	2.750%	-3.50%	1	0.01010101
7	94	-4.17%	94	0.0000014	0.9785	93	2.535%	2.750%	-3.00%	4	0.04040404
8	98	2.06%	93	0.0000083	0.9987	92	2.204%	2.750%	-2.50%	2	0.02020202
9	96	0.00%	92	0.0000000	0.9987	91	1.861%	2.750%	-2.00%	5	0.05050505
10	96	-3.08%	91	0.0000164	0.9679	90	4.556%	2.750%	-1.50%	0	0
11	99	0.00%	90	0.0000000	0.9679	89	14.895%	2.750%	-1.00%	21	0.21212121
12	99	-2.99%	89	0.0000151	0.9391	88	14.958%	2.750%	-0.50%	0	0
13	102	0.00%	88	0.0000000	0.9391	87	14.665%	2.750%	0.00%	26	0.26262626
14	102	-11.12%	87	0.0002108	0.8346	86	14.761%	2.750%	0.50%	0	0

2. Measuring asset volatility of listed banks by using Merton structural debt model

The steps for measuring asset volatility as in table 5.3 are: step 1, enter the value of outstanding debt in cell C6. Step 2, enter the risk free rate in cell C7. This research will use the average of daily JIBOR (Jakarta Inter-Bank Offered Rate) in each year as the risk free rate. Brooks and Yan (1999) mentioned that London Inter-Bank Offered Rate (LIBOR) can be used as the proxy for risk-free rate. Based on their statement, it means JIBOR can be used for proxy of risk-free rate because the rate reflects the real rate in the market and the movement of the real economy. Step 3, to measure the time to

exercise (days). This research employs an estimate of the average term to maturity of a bank's liabilities. The steps for getting an estimate of average term to maturity of bank's liabilities (C8) are: first, counting the sum of liabilities in each time maturity which is divided by total liabilities multiplied by each time of maturity. Second, count 250 transaction days divided by twelve months divided by the sum of liabilities maturity. Finally, enter the time to exercise (days) in cell C8.

Table 5.3 The Merton structural debt model

	C	D	E
Merton (1974) Structural Debt Model - call value			
Current asset value	3.44		guess-the result can be achieved by using solver menu
Asset Volatility	0.87		guess-the result can be achieved by using solver menu
Value of outstanding debt	3.13		The number of liabilities in the balance sheet
Risk free rate	0.05		the average of JIBOR
Time to exercise (days)	67.77688702		
Value of equity	0.3		This number is from Table 3.2 in cell C8
Volatility of equity	0.709424938		
d1	2.86605		$(\ln(C3/C6) + (C7 + 0.5 * C4^2) * C8 / 250) / (C4 * \text{SQRT}(C8 / 250))$
d2	2.82866		$C12 - C4 * \text{SQRT}(C8 / 250)$
N(d1)	0.99792		$=\text{NORM.DIST}(C12)$
N(d2)	0.99766		$=\text{NORM.DIST}(C13)$
Value of the equity call on the firm's asse	0.35		$C15 * C3 - C16 * \exp(-C7 * C8 / 250)$
Actual equity - call	0.00		$=C9 - C18$
Equity less no estimate of equity value	0.00		$=C9 - (C15 * C4 * C3 / C10)$
Squared total	0.00		$=C20^2 + C21^2$

Source : modified from (Ryan, 2007, p.348)

Step 4, to measure value of equity by multiplying closing share price with outstanding shares. Enter the result in cell C9. Step 5, take the number representing the volatility of

equity from cell O8 in the volatility estimator spread sheet (table 5.2) as the input for cell C10 in the Merton model spread sheet.

Step 6 involves measuring d_1 that is LN of current asset value divided by value of outstanding debt, add by risk free rate plus 0.5 multiplied by the square of asset volatility, multiply time to exercise divided by 250, then divided by asset volatility multiply square root of time to exercise divided by 250. Enter the result in cell C12. In the excel, it can be calculated by $(\text{LN } C3/C6) + (c7 + 0.5 \times C4^2) \times C8/250 / (C4 \times \text{SQRT } (C8/250))$.

Step 7, measuring d_2 , which is d_1 minus asset volatility multiplied by the squared root of time to exercise day divided by 250. In excel, it should be $C12 - C4 \times \text{SQRT } (C8/250)$. Enter the result in cell C13.

Step 8, measuring $N(d_1)$ is the normal distribution of d_1 , and enter the result in cell C15.

Step 9, measuring $N(d_2)$ is normal distribution of d_2 and enter the result in cell C16.

Step 10, measuring the value of the equity call on the firm's assets, that is $N(d_1)$ multiplied by current assets value minus $N(d_2)$ multiplied by value of outstanding debt, multiplied by exponent of minus risk free rate multiplied by time to exercise divided by 250. In excel, it can be calculated by $C15 \times C3 - C16 \times \exp(-C7 \times C8/250)$. Enter the result in cell C18.

Step 11, to measure actual equity is value of equity minus value of equity call on the firm's assets. Enter the result in cell C20.

Step 12, the estimate of equity value can be measured by value of equity minus $N(d_1)$ multiplied by asset volatility multiplied by current asset value divided by volatility of

equity. Enter the result in cell C21. After that, to measure the squared total is the actual equity to the power of two plus estimated equity value to the power of two, then enter the result in cell C22. The next step is to measure current asset value and asset volatility. Fill any number (just guessing) in the current asset value (cell C3) but it must be greater than the value of outstanding debt. Enter any number for asset volatility (in percent in cell C4) (just guessing). If the value of the underlying assets and their volatility cannot be calculated with ordinary math, a solution algorithm with Solver menu in the excel program can be used. Moreover, create the menu solver in excel with the target cell, which is the squared total (cell C22) and delta the total square of its cells, which are current asset value (cell C3) and asset volatility (cell C4). Volatility of asset value obtained is used as the estimated asset volatility for unlisted banks in the Black and Scholes pricing models option.

Furthermore, in order for the proxy bank equity volatility of listed banks obtained to be suitable for the approach used with the unlisted banks, the listed and unlisted banks should be classified in accordance with the similarity of their core business. For example, a cluster of banks which has a core business in retail, agriculture, corporate, etc. Nevertheless, after grouping based on their core business, most banks in Indonesia, large and small, are focused on retail business. Accordingly, not only is competitiveness among banks not fair, but also typical asset volatility of listed banks could not be used as a proxy for unlisted banks because it cannot reflect the real condition. For clustering banks in Indonesia, there are two options. First, based on Indonesian Banking Architecture (IBA); or, second, based on the bank of Indonesia's Regulation number

14/26/PBI/2012 about business activities and office network based on a bank's core capital.

First, banks in Indonesia can be grouped based on the IBA (www.bi.go.id). Since January 9th 2004, Bank of Indonesia has been planning the Indonesia Banking Architecture, which it intends would be implemented with a clear vision. The vision of the IBA was to create a sound and strong banking system, in order to create a stable and efficient financial system for encouraging the growth of the national economy. Within ten to fifteen years, the future capital improvement program is expected to lead the creation of a more optimal banking structure, namely the presence of: first, two to three of the banks moving towards the status of international banks, which have international capacity and the ability to operate in the region and internationally, and have capital above Rp.50 trillion. Second group is three to five national banks which have very broad scope of business and operate nationally and have capital between Rp.10 trillion and Rp.50 trillion. Third, thirty to fifty banks whose operations are focused on specific business segments in accordance with the capability and competence of each bank. These banks have capital between Rp.100 billion to Rp.10 trillion. Finally, a group of the Rural Banks and banks with limited scope. Those banks have capital below Rp.100 billion. Grouping banks based on IBA is only aimed at strengthening the structure of the national banking system, and the capital of the banks, in order to improve the ability of banks to manage the business and risks, develop information technology, and increase the scale of its efforts to support the growth of bank credit capacity. Thereby, clustering banks based on IBA is irrelevant for this measurement.

The second option for clustering banks is to refer to the BI regulation number 14/26/PBI/2012. This regulation classifies banks into four groups based on core capital (Bank Umum Kelompok Usaha =BUKU). First, BUKU 1 is a bank that has core capital less than one trillion Rupiah. Second, BUKU 2 is a bank which has core capital between one trillion Rupiah and less than five trillion Rupiah. Third, BUKU 3 is a bank which has core capital between five trillion Rupiah and less than thirty trillion Rupiah. Finally, BUKU 4 is a bank which has core capital at least thirty trillion Rupiah. Because this regulation is more clear and detailed in explanation not only of the classification of core capital, but also the kinds of business activities and network office in accordance with their core capital, therefore the clustering of banks within this study will be achieved with reference to this regulation.

After clustering the banks based on their core capital, then calculating the overall volatility of the asset volatility of each listed banks group, the result will be used as the input for estimating the asset volatility of unlisted banks in the Black and Scholes option pricing model, as shown in table 5.4.

3. Achieving equity volatility of unlisted banks by using Black Scholes Option Pricing model

The steps for measuring estimated value of equity as a proxy for firm value for unlisted banks are as follows:

First, enter the value of asset of the unlisted bank in cell C3 in table 5.4. Second, enter the value of liabilities in Cell C4. Third, enter the average JIBOR as the risk free rate in cell C5. Afterwards, enter the term to maturity of the liabilities (days) in cell C6. Next,

enter the volatility of listed banks' asset volatility which is in the same cluster with the unlisted bank in cell C7. In order to measure the overall volatility of each group of listed banks' assets volatility, there are three steps to follow. The output of this calculation will be used as an input for calculating the estimated value of unlisted banks' equity.

Step 1. Making a prices table

First, enter number of shares in the cell B8 and so for each bank in the same row in table 5.5. Second, enter the daily share price (Pt) for at least 101 days in the columns of each bank (B10 to B110). Third, calculate the market capitalization i.e. number of shares multiplied by end of the year closing price (B8*B10) and enter the result in cell B9.

Table 5.4 Black Scholes option pricing model for estimating value of equity

	A	B	C	D	E
1	A	B	C	D	E
2	1	Black and Scholes Option Pricing Model			
3	2				
4	3	Assets as per balance sheet	62.82		
5	4	Liabilities as per balance sheet	54.82		
6	5	Risk free rate	0.04021214	The average of JBICR	
7	6	term to maturity in days	36.68		
8	7	Asset volatility	0.0492	the volatility of listed banks' assets volatility which is in the same group with the unlisted banks	
9	8	Dividend yield paid to investors	0.0000		
10	9	d1	7.55062	$=\frac{\ln(C3/C4)+(C5-C8+0.5*C7^2)*C6/250}{C7*\text{SQRT}(C8/250)}$	
11	10	d2	7.53177	$=C9-C7*\text{SQRT}(C8/250)$	
12	11				
13	12	N(d1)	1.00000	$=\text{NORMSDIST}(C9)$	
14	13	N(d2)	1.00000	$=\text{NORMSDIST}(C10)$	
15	14				
16	15	Estimated value of equity	0.32	$=C12*C3*\text{EXP}(-C8*C6/250)-C13*C4*\text{EXP}(-C5*C6/250)$	
17	16	Shares in issue			

Source: Ryan (2007)

Step 2. Making a relatives table

In making a relatives table, it should be on another sheet (table 5.6). First, calculate price relatives of daily share price i.e. number of cell B10 (Pt) in table 5-5 divided by share price at t-1 (cell B11), minus 1. The formula is $(P_t/P_{t-1}) - 1$ and in excel this is $(B10/B11) - 1$. Then, enter the result in the cell B5 to B102 in table 5.6. Second, put the standard deviation of price each bank from Table 3 at cell C4 to table 5.6 in the cell B3 and so on. Third, calculate the weights i.e. market capitalization each bank in the table 5.5 divided by total market capitalization (in excel is B9/G9) and put the result in cell B4 and so on.

Step 3: Making a correlation table

There are three steps in making correlation for calculating the overall volatility First, type the weights from table 5.6 into table 5.7 in the cell D1 (horizontally) and in to cell C2 (vertically). Second, calculate standard deviation of weights each bank i.e. ω_i^2 . In excel is squared of cell D1 in the table 5.7 multiplied by squared of cell B3 in the table 5.6 i.e. $(D1^2 * \text{Relatives} / (B3)^2)$. Then, enter the result in cell D2, and so on. Finally, calculate the overall volatility of the asset volatility the each group of listed banks i.e. square root of the total of the weighted in table 5.7. In excel, it can be calculated by $(\text{SQRT}(\text{SUM}(D2:G5)))$.

The result of those steps will be used as the input for asset volatility for unlisted banks, which are in the same groups as listed banks. Next, enter the result (C7 in table 5.7) into table 5.4 in cell C7.

Table 5.5 Daily share price

NO	BRI	MANDIRI	BNI	BCA	TOTAL MC
1	6950	7800	3750	6200	
2	6950	8100	3700	6200	
3	6950	7800	3750	6900	
4	6950	8000	3750	6200	
5	6950	8000	3675	9050	
6	6950	8000	3675	6150	
7	6950	8000	3675	6200	
8	6900	8000	3675	6250	
9	6950	8000	3675	6450	
10	6900	8100	3600	6450	
11	7000	8150	3800	6250	
12	7000	8050	3625	6150	
13	7200	8000	3675	6800	
14	7200	8100	3600	6800	
15	7050	8000	3675	6800	
16	7050	7950	3675	6750	
17	7050	7950	3675	6500	
18	7150	8100	3675	6800	
19	7100	8200	3600	6800	
20	7100	8150	3625	6950	
21	7050	8450	3650	6950	
22	7050	8250	3700	6100	

Table 5.6 Relatives

BRI	MANDIRI	BNI	BCA
0.00%	7.67%	3.73%	12.38%
0.288194342	0.278813177	0.146438674	0.542719667
0	-0.077033237	0.13513814	0
0	0.938451538	-0.11303337	0.032707997
0	-0.6265	0	-0.020586393
0	0.020408163	0.016574588	0
0	0	0	-0.010028932
0	0	0	-0.005434783
0.887246377	0	0	-0.005405405
-0.887164248	0	0	-0.021164021
0.887246377	-0.018346796	0.020633333	0
-0.814287718	-0.098134968	0	0.021521632
0	0.81242238	-0.06686666	0.010828952
-0.827777778	0.20628	0.13886918	0.382727272
0	-0.012345678	-0.0084444	0
0.821278596	0.0125	0.006893007	0
0	0.956289308	0	0.005714288
0	0	0	-0.028047399
-0.812866014	-0.18518519	0	0.079545405
0.887542254	-0.012185122	-0.0084444	-0.022222222
0	0.93814568	-0.06689555	0.055888932
0.887892199	-0.03552959	-0.0064932	0
0	0.924242424	-0.1351381	-0.018483918
-0.878833333	-0.81724138	0.146438674	0.007028932
0.888882007	0	-0.0084444	0.016823933
0	-0.89714286	0	0.005448759
-0.813783103	0.038881818	0	0
0.82836794	0.11484853	-0.06686665	0.070697517

Table 5.7 The correlation

		C	D	E	F	G
1		weights (w)	0.269296342	0.2780533	0.110430874	0.342219467
2	BRI	0.269296342	0.000184945	0	0	0
3	MANDIRI	0.278053317	0	0.0004489	0	0
4	BNI	0.110430874	0	0	1.69668E-05	0
5	BCA	0.342219467	0	0	0	0.00177182
6	TOTAL	1	0.000184945	0.0004489	1.69668E-05	0.00177182
7	the overall volatility of the asset volatility the each group of listed banks	4.92%				

Because unlisted banks do not pay dividends, so dividend in cell C8 in table 5.4 is zero. The d_1 can be measured by $d_1 = (\ln(\text{asset}/\text{liabilities}) + (\text{risk free rate} - \text{dividend} + 0.5 \times \text{volatility}^2 \times \text{time to exercise}/250)) / (\text{volatility} / \sqrt{\text{time to exercise}/250})$. Enter the result in cell C9. Moreover, the d_2 can be counted by $d_1 - \text{asset volatility} \times \text{term to maturity}$. Enter the result in cell C10. The $N(d_1)$ and $N(d_2)$ can be measured by normal distribution of C9 and C10 respectively. Finally, the estimated value of equity can be achieved by $N(d_1) \times \text{assets} \times \text{exponent} - \text{dividend} \times \text{term to maturity} / 250 - N(d_2) \times \text{liabilities} \times \text{exponent} - \text{risk free rate} \times \text{term to maturity} / 250$. Enter the result in cell C15 in table 5.4. This result of these steps will be used as a proxy of firm value for unlisted banks.

All in all, by using the Black Scholes option pricing and Merton structural debt model, call option on its assets can be used as a proxy for the unlisted firm's equity. Along with that, measuring firm value for unlisted banks will be calculated by employing Black Scholes Merton models.

5.5.2 Independent variables

Based on the research aim which is to analyse the relationship between the determinants and value relevance of risk disclosure in the Indonesian banking sector, the determinants will be explained as follows:

Firm Size (X1)

Firm size is one of the most important factors which impact the level of risk disclosure. Firm size could be measured by the following methods for example, market capitalisation, total sales, total employees, total assets, total revenue. The variable of firm size in this study will be measured by total assets, because assets could reflect the wealth of a company. Moreover, it is either the basis of a company's financial performance measurement or the comparison of achievement among the same industries. In addition, due to the population consisting of listed and unlisted banks, while unlisted banks do not have market capitalisation; and banks do not have total sales, hence total assets are more appropriate and objective than other variables for reflecting firm size. Then, Firm Size = Total Assets.

Liquidity (X2)

Liquidity is a capability of bank to pay short term debts. For measuring liquidity, this study employs Loan to Deposit Ratio (LDR). The LDR reflects the extent of the bank's ability to repay fund withdrawal by depositors by relying on loans. The LDR demonstrates how much a bank maintains their liquid assets or deposits compared to how much they release funds throughout outstanding credits. The higher the LDR, the higher the amount of funds required to finance the greater credit.

The BI regulation number: 06/10/PBI/2004 concerning rating system for commercial banks, the requirement for the LDR lower limit is 78% and for the upper limit is 120%. The LDR is the comparison of total loans to the total of third party funds. Credits (loans) mean the loans to third party (not including loans to other banks), while third party funds include demand deposits, savings, and time deposits (not including inter banks). Therefore, in this study LDR is measured by loans / total third party funds.

Profitability (X3)

Profitability ratio is a measurement to demonstrate the persistence of a company to generate profit. According to Lee (2006), profitability ratio is used to evaluate the firm's management success in generating earning for supplying funds for upcoming replacement and development companies and returns for shareholders. To measure the profitability associated with disclosure, this research employs Return on Equity (ROE) because it reflects the signal to meet shareholders' needs. Wachowicz (2005) asserted that the profitability ratio using return on equity (ROE) is suitable for measuring firm profitability related to the investment. Return on equity (ROE) is the rate of return on an owners' share of the company. This ratio is widely observed by the bank's shareholders

and investors in the capital market who want to buy shares. In addition, Return on Equity (ROE) is the main attention of the shareholders, as it pertains to shares invested in the company. Furthermore, ROE is significant for assessing the financial performance of the company to meet shareholders' expectations (Helfer, 2001). The ROE can be measured by profit for the year divided by equity or earning after interest and taxes divided by equity.

Leverage (X4)

Leverage ratio is a firm's financial ratio for measuring the company's ability in paying long term debt. Watson et al. (2002) explained that leverage is considered as the variable of the model because first it demonstrates the company's ability in using debt to increase profits. Second, leverage can be used as consideration in viewing the potential bankruptcy risk of a company because most of the bank's sources of funds are debts. Third, Höring and Gründl (2011) mentioned that leverage ratio is a popular ratio in risk disclosure study. Fourth, D'Hulster (2009) asserted that banks with high leverage supported the previous financial crisis in 2007. This research, leverage is calculated by debt divided by total assets.

Earnings reinvestment (X5)

Bank (2004) defines that earnings reinvestment is earnings that will not be paid to the shareholders but will be retained and reinvested in its main business to support a company's growth opportunities. Moreover, Bodie et al. (2011) stated that companies which distribute large dividends initially will have low reinvestment opportunities and in the future dividends growth rate will be low. Conversely, if the company has an earning reinvestment policy, while initially investors will receive small earnings, in the long-term

investors get benefits by receiving high dividends thereby increasing the value of shares (Figure 4-1). In other words, the companies with a high reinvestment rate generate higher dividends in the future and finally it will boost firm value. The earnings reinvestment (b) is calculated by earnings per share (EPS) minus dividends per share (DPS) divided by earnings per share (Ryan, 2007, p.377).

Risk Disclosure (X6)

There is a real projection independent of manager's concept of risk. From the finance perspective, risk is driving the value of the firm. The formal risk is measured by volatility. Risk represents the volatility of the firm's underlying assets measured by standard deviation by statistical tool.

Subramanian and Reddy (2012) mentioned that disclosure is releasing information for the public pertaining to the companies' activities and performance evaluation in the interest of stakeholders. In this study, risk disclosure is to convey firm risk information to the market through annual reports. This is measured by a number of Indonesian risk keyword divided by number of Indonesian sentences in annual reports.

The proxies for the independent variables as determinants are mostly ratios, respectively:

Firm Size (X1) is measured by Total Assets.

Profitability (X2) is measured by ROE (Return on Equity) = Earnings after tax/ Equity

Liquidity (X3) is measured by Loan to Deposit ratio (LDR) or Financing to Deposit Ratio (FDR) for Islamic Banks (based on the BI regulation No.6/ 10/SBI/2004 31 May 2004), that is Loan/third sources of funds.

Leverage (X4) is measured by debt/assets.

Earnings reinvestment (X5) is measured by $b = (EPS - DPS) / EPS$.

Risk disclosure (X6) is measured by number of Indonesian risk keyword / number of Indonesian sentences in annual reports.

Empirical Models

The model of the relationship between the delta of risk disclosure (RD) as the dependent variable and the delta of determinants of risk disclosure as independent variable are as follows:

Equation 5- 1: Model 1

$$\Delta RD = \beta_0 + \beta_1 \Delta \text{assets} + \beta_2 \Delta \text{LDR} + \beta_3 \Delta \text{ROE} + \beta_4 \Delta \text{Lev} + \beta_5 \Delta b + \varepsilon$$

The model of the relationship between the delta of firm value (FV) as the dependent variable and the delta of risk disclosure and the delta of the determinants of firm value as independent variable are as follows:

Equation 5- 2: Model 2

$$\Delta FV = \beta_0 + \beta_1 \Delta \text{assets} + \beta_2 \Delta \text{LDR} + \beta_3 \Delta \text{ROE} - \beta_4 \Delta \text{Lev} + \beta_5 \Delta b + \beta_6 \Delta \text{RD} + \varepsilon$$

This study employs a comparative analysis to be able to exhibit company performance progress over time. The developments of ratio over time will be calculated by the delta, the difference of the numbers or ratio current year with the last year, based on several premises. First, narrative information that describes the increase or decrease of the ratio

provides more information that can reflect the actual growth rate than merely the limited numbers. Hence, the numbers would be useless if they are not compared with other information. Thereby, the information using the Δ (increase or decrease) becomes more meaningful for users. Second, based on the difference of the numbers of the delta, instead the annual financial report will be used to explain in more detail the meaning of delta and why it happened. Third, in this study, the number of words in a sentence such as "increase", "decrease", "decline" will be a proxy for risk disclosure that illustrate or have the same meaning as interpretation of delta between risk disclosure in this year and the previous year. In addition, by analysing the number of Δ RD, it can be seen whether the company increase or decrease in explaining risk disclosure or whether they convey the signals in more detail and transparently compared to previous years.

Based on the signalling theory, when companies are more transparent, asymmetric information will decrease. Thereby, when investors perceive financial statements and annual report as providing accurate and credible information, it illustrates that the company is more transparent in risk, and show low levels of asymmetric information.

In line with the research objective and research questions, how the extent and quality of risk disclosure in the Indonesian banking sectors can be effectively quantified, it can be used as a reason why the research model uses the Δ RD. First, Δ RD indicates the extent of changes in the level corporate-disclosure. Second, the delta can be used to compare the change of risk disclosure's extent each year and between firms (decrease or increase compare with previous year).

Third, Collins (1989) highlighted that the difference is more useful in forming expectations of the company's future performance. Fourth, the delta used to reduce the dependence between the period and the earning does not necessarily indicate growth opportunities now, but could be due to change of growth or decline in economic activity in the previous period. Fifth, the time series data has an autocorrelation problem, while an autocorrelation supports non stationary. The data are stationary if the mean, variance and covariance are constant. A test of stationary is the Unit Root test. In the unit root process, the data will be smooth (white noise error) and stationary by employing delta (Gujarati & Porter, 2009). Finally, it is clear that the explanation of the $\Delta (Y_t - Y_{t-1})$ become more meaningful.

In the model 2, this research employs Δ firm value because it is expected that the increase of firm size, liquidity, profitability, earnings reinvestment, risk disclosure, and the decreasing of leverage can boost firm value. By Δ FV, it can be seen whether the firm value increased or decreased compared to the previous year.

The fundamental weakness in using the determinants is biased against the number of independent variables used in the model. If a variable is added to the model association, it will certainly increase no matter whether the variables affect the dependent variable. Therefore, when evaluating the best regression model, this research will use the adjusted values (adjusted R square). Regarding to the result of r, "in the social science r^2 as low as 0.25 are considered useful" (Hussain & Al-Ajmi, 2012, p. 580).

To compare listed and unlisted banks, Islamic banks and non-Islamic banks, risk disclosure will be measured by t independent test. The definition of t test according to

Rock (2007) “the t test for two independent samples is an inferential statistic used to examine the disparity between two population means, which in turn correspond to the means of two independent samples”

The measurement of homogeneity in the correlation can be used to find the difference in correlation coefficients across different groups, however the bias can be detected by a pre-test. Statistical software, such as SPSS, can examine the Levene test for testing the homogeneity of variance in these groups. Before using T independent test, the data will be examined by Levene test (homogeneity of variance), because the number of listed banks on the Indonesia Stock Exchange (32 banks) and unlisted banks (88 banks), the Islamic banks (11) and non-Islamic banks (109) are not equal. Homogeneity of variance can be used to test the similarity of some samples. Generalisation of the population can be made by the Levene test. Levene Test will appear along with the t-test results. The criteria is significant value or the value probability is < 0.05 , it means data derived from a different variance of population, while if the probability value significant > 0.05 it means data derived from a same variance of population.

This research examines fourteen hypotheses that will be tested by quantitative methods and then make a conclusion whether the hypothesis is accepted or rejected. Before examining the hypothesis, it is important to test the data that are free from bias, by investigating the association among variables and checking whether they are free from multicollinearity, heteroscedasticity, and autocorrelation. Due to this research employing large data and panel data, a normality test is not needed (Gujarati & Porter, 2009, p. 99).

The association between the determinants of firm characteristics namely firm size, liquidity, profitability, leverage, earnings reinvestment and risk disclosure then association between firm characteristics, risk disclosure and firm value will be examined by Partial and Multiple correlation analysis with $\alpha = 5\%$ (Neter, 1996).

Value Relevance

Moumen et al. (2013) mentioned that value relevance is if the information in annual reports is transparent and valuable and useful for investors. According to A. Filip and Raffournier (2010) value relevance can be described as value relevant if its coefficient is statistically significant. Moreover, Agostino et al. (2011) asserted that value relevance is estimated by the degree of explanatory power of the model. In this research, the coefficient of significant statistical is employed for examining the value relevance of risk disclosure as it had adopted by Beisland (2009).

5.6 Validity and Reliability Test

Before testing the research models, it must be ensured that the variables can be used accurately, trustable, valid, acceptable and reliable. Moreover, to make sure that the measurements work the job properly, it should be tested by reliability and validity. This study employs counting sentence which has at least one of the risk keywords in Indonesian language, it is crucial for assuring those keywords are valid and reliable for this research, hence they must be tested by validity and reliability tests. The first step for validity and reliability test is to choose banks' annual reports randomly as the samples. There are 21 banks (17.5%) of total banks in Indonesia (120) are pointed as the samples. Second, due to some annual reports not being in English language, the

keywords must be translated into Indonesian language. In order to make sure that the meanings are the same, the keywords were translated by three people who are experts in finance and three English teachers who understand English and Indonesian language well. Third, to count sentences containing keywords related to risk, at least one risk keyword in each sentence, software NVIVO was used. Total score will be tested for reliability and validity by using SPSS. If the Cronbach's Alpha shows more than 70%, it means the measurement is reliable. Moreover, if a keyword has r statistic higher than r table this means the keyword is valid, and those keywords will be used for measuring risk disclosure.

Due to the first research objective being to measure the extent of risk disclosure in Indonesian banking sector and most of the annual reports were issued in Indonesian language, along with that the translation of keywords from English language into Indonesian language must be tested by validity before processing. The result of Indonesian risk keywords are:

Akibat, aktif, ancaman, banyak macam, banyak mendapatkan, barangkali, benar mengetahui, bencana, bencana alam, beragam, berarti, berbeda, berfluktuasi, bergantung, berkurang, bermakna, bermasalah, bersemangat, berubah-ubah, bervariasi, bisa, boleh, boleh jadi, celaka, cenderung, dapat, dapat diduga, daya kerja, ditengarahi, diversifikasi, fluktuasi, gagal, gangguan, gersang, hilang, hina, keadaan tidak stabil, kebalikan, kedapatan, kegagalan, kehilangan, kekuatan, kekurangan, kemajuan, kemunduran, kemungkinan, kemungkinan besar, kemungkinan rugi, kenaikan, kerugian, kesanggupan, kesempatan, ketidakpastian, ketidaktentuan.

The next step is to calculate risk disclosure using the valid keywords by QSR. When the annual reports were published in dual languages (Indonesian and English) the total sentences will be divided by two.

Validity

There are 61 risk keywords in English language, nevertheless after translating the keywords into Indonesian languages the keywords became 150 keywords. It happened because a keyword has some same meaning (synonyms). After examining by NVIVO onto 21 annual reports as pre testing, some Indonesian keywords were not found in the annual reports and the rest keywords are 69.

For making sure the Indonesian keywords are valid, they were tested by validity test. After testing with validity test, 28 keywords are not valid because r statistic is less than r table (0.433), and should be excluded. Finally, the 41 risk keywords that are valid for measuring risk disclosure are: *aktif; akibat; ancaman; berbeda; dapat; mampu; tidak bisa; tidak dapat; boleh; kemungkinan; risiko; kerugian; potensi; berkurang; kekurangan; kurang; mengurangi; bermasalah; berubah; dampak; fluktuasi; gangguan; menambah; kenaikan; kesempatan; mendapatkan; keuntungan; mencapai; perolehan; lindung nilai; masalah; melanggar; mempengaruhi; meningkat; meningkatkan; menurun; turun; penting; tertinggi; signifikan; tidak stabil.* (appendix B).

Reliability

The result indicates Cronchbach's alpha is 0.79 (> 0.70), that means the keywords have a high reliability, consistence and can be used more than once or another research

whereby the result will produce a consistent data when those keywords are used in other research.

5.7 Summary

This research tends to positivism because the purpose of theory is to generate hypotheses. This study employs quantitative methods (econometric models) to find factors determining risk disclosure and firm value. Moreover, this research analyses the differences of risk disclosure between listed and unlisted banks, Islamic and non-Islamic banks. In addition, this study uses secondary data for statistical data analyses to provide information associated with the determinants on risk disclosure and firm value and value relevance of risk disclosure.

The relationship between dependent and independent variables are tested with two models. First model is the association between the delta of risk disclosure and the delta of firm characteristics, namely: firm size, liquidity, profitability, leverage, and earnings reinvestment. Second model is the association between the delta of risk disclosure, the delta of firm characteristics, and the delta of firm value.

This study employs counting sentences which have at least one risk keyword divided by number of Indonesian sentences in the annual report for quantifying risk disclosure,. There are 41 Indonesian risk keywords that valid and reliable which can be used for measuring risk disclosure. In order to measure firm value listed banks, this study employs Tobin's Q, while for unlisted banks will be used a new approach namely Black Scholes Merton model. In 1973, Fischer Black and Myron Scholes found a model to determine the price of the option (option-pricing). Black-Scholes model is obtained from

the integration process of the stock price which is influenced by several factors, including stock price, strike price, interest rate, time to exercise and volatility. Moreover, the BSM model is able to estimate value of equity.

The variables which are used in the calculation of firm value of unlisted banks are: a closing share price (P_0) as a proxy for asset value (A_0), the strike price (P_e) as a proxy of liabilities value (L_e), term to maturity (t) is calculated from the maturity of liabilities, risk free risk (r) is calculated by proxy JIBOR (Jakarta Interbank Offer Rate) and price volatility stock (σ) as a proxy for asset volatility (σ_A). For calculating those models, it employs excel/spreadsheet software. There are three main spread sheets for calculating the estimated value of equity of unlisted banks, and each spread sheet has many stages. First, a volatility estimator for calculating the number of equity volatility of listed banks. Second, a spread sheet of Merton structural model of debt to acquire assets volatility of listed banks. Finally, Option Black Scholes Pricing models spread sheet for gaining estimated equity value of unlisted banks.

Because the unlisted banks do not have stock price volatility, the volatility assets values of listed banks which are calculated by Merton structural model of debt, will be used as the basis for calculating the estimated volatility of asset of unlisted banks with Black Scholes option pricing models. In order for these values to be comparable, similar and reflect the actual comparison, the bank listed and unlisted banks are classified by core capital based on the BI regulation number 14/26/ PBI/2012.

The BSM model is an appropriate method for measuring the value of firm that most of their sources of fund are financed by loan such as banks. It means the BSM model can be used for measuring firm value of unlisted banks and suitable for this research.

For answering the research aim and analysing the relationship between the delta of firm characteristics, and the delta of risk disclosure, then association between the delta of risk disclosure and the delta of the firm characteristics and the delta of firm value, the models will be examined by partial and multiple correlation analysis. For testing the value relevance of risk disclosure, this research employs the statistical coefficient of regression of the correlation between risk disclosure and firm value.

CHAPTER 6

EMPIRICAL RESULTS AND ANALYSIS

6.1 Introduction

This chapter has eight sub-chapters that explain the empirical results. The first sub-chapter offers an introduction to explain the main discussion that answers the research questions. The second sub-chapter describes the research population. The result of the classic assumption tests is explained in subchapter three. The fourth sub-chapter provides the result of the first research questions, i.e. how the extent of risk disclosure can be quantified. The results of the differences between the extent of risk disclosure between listed and unlisted banks, and between Islamic and non-Islamic banks are presented in sub-chapter five. The sixth sub-chapter provides data relating to the factors which affect a bank's decision to disclose risk. The results in terms of the value relevance of disclosure by listed and unlisted banks, Islamic and non-Islamic banks are presented in sub-chapter seven. Finally, this chapter is closed with a conclusion.

6.2 The Research Population

The development of total banks in Indonesia from 2008 to 2012 is demonstrated in table 6.1. It can be seen that the total number of banks in Indonesia tended to decrease slightly, while the numbers of listed banks and Islamic banks were on the increase. Moreover, the total number of unlisted banks and non-Islamic banks tended to decrease. This indicates that the unlisted banks were eager to increase their status into becoming listed banks. In 1992 the Indonesian government issued Law number 7/1992 that offered an opportunity for Islamic banks to open, and since 2009 the number of Islamic banks has been on the increase.

Table 6.1 Total banks in Indonesia over the period 2008 to 2012.

	2008	2009	2010	2011	2012
All banks	124	121	122	120	120
Listed banks	28	29	31	31	32
Unlisted banks	96	92	91	89	87
Islamic banks	5	6	11	11	11
Non-Islamic banks	119	115	111	109	109

Sources: www.bi.go.id, www.idx.co.id, The Directory Indonesian Banking. Bank of Indonesia 2009-2013

The main source of this research was banks' annual reports. In order to obtain the annual reports, they had to be downloaded through their website or the Indonesia stock exchange's website. The impediments to downloading banks' annual reports were: first, even though some banks put a link for downloading their annual reports, it could not be opened. Second, some of the annual report could not be opened because they had a password and in file exe. Third, annual reports were sometimes made available separately per each part. Fourth, the PDFs were sometimes blurred and therefore could not be read.

This study employs a population of banks in Indonesia which released complete annual reports and financial reports over the period 2008-2012. Accordingly the total population is 120 banks and therefore the total data should be 600 annual reports (120 banks x 5 years). Nevertheless 187 annual reports were deleted (see appendix E) for various reasons, which were: five banks were not established before 2010, namely BNI Shariah, BCA Shariah, Maybank Shariah, Jabar Shariah, Victoria Shariah, while Panin Shariah was established in 2009; 16 annual reports were blank when they were converted into text; four annual reports could not be converted; 14 annual reports could not be downloaded; four texts were damaged; 132 annual reports were not available; six annual

report could not be opened because of a password, thereby total data is 413. By deleting 187 annual reports (31.2%) from 600, this might produce a bias which could distort the information obtained and the results may be not represent the actual situation. However, although any bias would be difficult to quantify there did not appear, on inspection of the banks excluded, any reason to believe that they were untypical of the population of banks more generally.

This study employs delta for each variable in the models, based on the difference between year t and year $t-1$. Based on total listed banks there are 32 banks, nevertheless three of them had changed from unlisted to listed banks since 2010 and one of them was only established in 2012: finally, the total data (N) was 312, and each sector based on listing was: 116 listed banks and 196 unlisted banks; while based on Islamic system there are 27 Islamic banks and 285 non-Islamic banks (see appendix C).

6.3 Classic Assumption Tests

The data of this research is categorised ratio and it employs a large number of data that can be assumed to have a normal distribution. Therefore, this study used parametric method. In addition, Gujarati and Porter (2009, p. 100) asserted that the normality assumption is not crucial as needed for large data. Due to large data (N) being 312 for total banks and more than 100 for each sector, it means that data are assumed to have a normal distribution. Meanwhile, since the N of Islamic banks is only 27, it must be tested by normality test. The result of the normality test for Islamic banks is demonstrated in appendix F. Based on the table in appendix D, all variables were more than 0.05 and less than t table, which implies that all variables for Model 1 and Model 2 did not have a heterocedasticity problem. The data showed higher than 0.1 and VIF was less than 10,

meaning those variables did not have a multicollinearity problem. The results showed that the models are free from autocorrelation problems. Due to the data not having a problem with normality, heteroscedasticity, multicollinearity, and autocorrelation, the data can be processed further in order to answer research questions and hypotheses.

Table 6.2 Summary of tolerance and VIF for the correlation with risk disclosure

Variables	All banks		Listed banks		Unlisted banks		Islamic banks		Non-Islamic banks	
	Tolerance	VIF	Tolerance	VIF	Tolerance	VIF	Tolerance	VIF	Tolerance	VIF
Assets	0.961	1.041	0.959	1.043	0.896	1.116	0.883	1.133	0.962	1.039
LDR	0.912	1.097	0.952	1.051	0.786	1.272	0.922	1.084	0.887	1.127
ROE	0.986	1.015	0.986	1.014	0.897	1.115	0.912	1.097	0.986	1.015
Leverage	0.880	1.137	0.978	1.022	0.785	1.273	0.872	1.146	0.863	1.158
Earnings Reinv.	0.953	1.050	0.943	1.060	0.880	1.136	NA	NA	0.949	1.054

Source: adopted from SPSS

Table 6.3 Summary of tolerance and VIF for the correlation with firm value

Variables	All banks		Listed banks		Unlisted banks		Islamic banks		Non-Islamic banks	
	Tolerance	VIF	Tolerance	VIF	Tolerance	VIF	Tolerance	VIF	Tolerance	VIF
Assets	0.959	1.043	0.952	1.050	0.896	1.116	0.596	1.677	0.959	1.042
LDR	0.903	1.107	0.949	1.054	0.784	1.276	0.900	1.111	0.874	1.144
ROE	0.985	1.015	0.983	1.017	0.876	1.142	0.880	1.137	0.986	1.015
Leverage	0.875	1.142	0.969	1.032	0.755	1.324	0.674	1.484	0.861	1.161
Earnings Reinv.	0.953	1.050	0.938	1.066	0.879	1.137	NA	NA	0.949	1.054
Risk disc.	0.979	1.021	0.971	1.030	0.931	1.074	0.751	1.331	0.973	1.028

Source: adopted from SPSS

6.4 The Results Of RQ1: How Can The Extent Of Risk Disclosure In The Indonesian Banking Sector Be Effectively Quantified?

Table 6.4 and figure 6.1 show the average number of Indonesian risk keyword instances reported by all banks and the average number of risk disclosure in each bank sector for every year between 2008 and 2012. It can be seen in figure 6.1 that the average number of Indonesian risk keywords demonstrated an upward trend for all banks and each bank

group. Nevertheless, unlisted banks showed a small decrease in 2009 from 416.47 to 359.52, and then in 2010 the number of risk keywords increased rapidly. The Islamic, non-Islamic and unlisted banks rose gradually while listed banks climbed sharply, by almost 360 keywords from 959.77 to 1319.13, particularly in 2011 to 2012. During the period 2008 to 2012, the number of risk keywords in listed banks was always higher than other sectors; conversely, Islamic banks mostly had the lowest number. The number of risk keywords in listed banks was higher than unlisted banks, while non-Islamic banks were higher than Islamic banks.

Table 6.4 The average number of Indonesian risk keywords in all annual reports

	2008	2009	2010	2011	2012	Average (2008-2012)
ALL BANKS	413.81	441.54	532.63	688.97	850.65	617.30
LISTED	573.37	579.32	743.26	959.77	1319.13	849.85
UNLISTED	416.47	359.52	416.04	565.88	661.71	491.49
ISLAMIC	311.50	368.20	375.50	469.00	525.09	432.70
NON-ISLAMIC	421.25	447.45	553.04	714.55	889.16	637.10

Source: adopted from SPSS

The lowest and the highest number of risk keywords fluctuated and came from many variations of bank. The lowest number of risk keywords in 2008 was eight in all banks and the highest was 2096. The lowest number of total risk keywords recorded was for the Windu Kencana bank, a listed and non-Islamic bank. The Niaga was the highest bank, which was a listed and non-Islamic bank.

In 2009, the lowest bank was Fama (72), as unlisted and non-Islamic bank. On the other side, Niaga bank (1572), as listed and non-Islamic bank remained the highest in terms

of risk keywords for two years. Again in 2012, Niaga bank was able to achieve the highest number of risk keywords, while the smallest number was BPD Sulawesi Tenggara which only had seven risk keywords in its annual reports.

Table 6.5 The lowest and the highest number of risk keywords

Year	Bank sector	N = 413	risk keywords				SD
			the lowest		the highest		
			bank	number	bank	number	
2008	All banks	59	WINDU KENCANA	8	NIAGA	2,096	339.24
	Listed	27	WINDU KENCANA	8	NIAGA	2,096	421.59
	Unlisted	32	BPD BALI	29	OCBC NISP	613	159.25
	Islamic	4	BUKOPIN SYARIAH	137	MANDIRI SYARIAH	444	148.33
	Non-Islamic	55	WINDU KENCANA	8	NIAGA	2,096	348.65
2009	All banks	67	FAMA	72	NIAGA	1,572	301.30
	listed	25	SWADESI/BANK OF INDIA	111	NIAGA	1,572	364.76
	Unlisted	42	FAMA	72	BPD.DKI	935	223.13
	Islamic	5	MEGA SYARIAH	189	MUAMALAT	536	136.70
	Non-Islamic	62	FAMA	72	NIAGA	1,572	310.68
2010	All banks	87	BANK OF CHINA	77	BII	2,063	380.05
	Listed	31	CAPITAL	184	BII	2,063	473.94
	Unlisted	56	BANK OF CHINA	77	BPD.DKI	1,297	253.93
	Islamic	10	PANIN SYARIAH	101	BRI SYARIAH	717	222.37
	Non-Islamic	77	BANK OF CHINA	77	BII	2,063	392.32
2011	All banks	96	INA PERDANA	85	BII	2,278	485.40
	Listed	30	BCA	133	BII	2,278	571.51
	Unlisted	66	INA PERDANA	85	BPD.DKI	2,246	386.51
	Islamic	10	MAYBANK SYARIAH	200	MANDIRI SYARIAH	905	226.56
	Non-Islamic	86	INA PERDANA	85	BII	2,278	714.55
2012	All banks	104	BPD.SULAWESI TNGGR	7	NIAGA	2,627	562.29
	Listed	31	SWADESI/BANK OF INDIA	19	NIAGA	2,627	647.84
	Unlisted	73	BPD.SULAWESI TNGGR	7	BPD.SULAWESI SLTN	1,995	377.89
	Islamic	11	VICTORIA SYARIAH	86	MUAMALAT	1,265	351.22
	Non-Islamic	93	BPD.SULAWESI TNGGR	7	NIAGA	2,627	571.31

Source: adopted from QSR6

The bank of China, as an unlisted, non-Islamic bank, had the lowest number of risk keywords (77) in 2010; meanwhile BII had the highest number of risk keywords (2063).

BII was able to maintain its position as the highest in terms of risk keywords in 2011. Conversely, Ina Perdana had the smallest number of risk keywords. The rising trend also implies that all the banks were trying to represent risk more transparently in their annual reports, as indicated by the fact that the total number of Indonesian risk keyword went up every year during the research.

Table 6.5 shows there was a big gap between the lowest and the highest number of total risk keywords in listed and unlisted, Islamic and non-Islamic banks. This indicates that some banks were still reluctant to reveal the extent of their risk in their annual reports, even though they were listed banks. On the other hand, some banks were enthusiastic in describing their performance in more detail. This was also reflected in the variation of how they explained the risks in annual reports. This is in line with Mohobbot (2005) and Lajili and Zeghal (2005) who mentioned that the content and level of reporting of risk in annual reports had large variations.

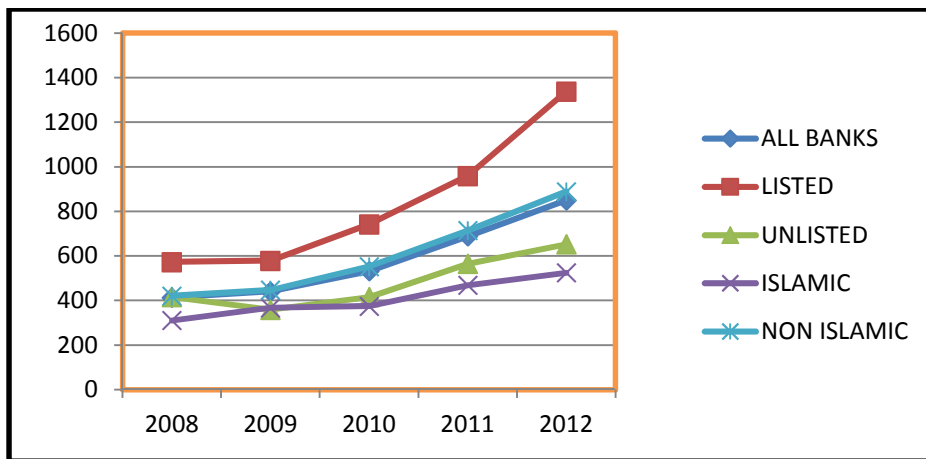

Figure 6-1 The average number of total risk keywords

The trend in the numbers of Indonesian sentences in the banks' annual reports between the years 2008 to 2012 are shown in table 6.6 and figure 6.2. The graph describes that all sectors had an upward trend, even though in 2009 all sectors declined slightly; however, after 2010 the total sentences in the annual reports climbed sharply.

The listed banks in the five years always denoted the highest numbers of total sentences compared with other sectors. The total sentences of the listed banks was bigger than the unlisted banks, meanwhile the non-Islamic banks' number of sentences were greater than the Islamic banks, not only every year but also the average of total sentences from 2008 to 2012. The total sentences of listed banks and non-Islamic banks went up massively every year after 2010, while unlisted and Islamic banks increased slightly. This may have been because one of the consequences of being a listed bank is that they must report their performance more transparently because investors need more detailed risk information.

Table 6.7 shows that banks had many variations of length in sentences when they explained their performance in annual reports. In 2008, the least number of sentences for all banks was BPD Bali (269), as an unlisted and non-Islamic bank, conversely the largest number was Niaga, as a listed and non-Islamic bank, which had 41,818 sentences. The variation of the number of sentences indicates that some banks reported their performance in a lot of detail while others were being less transparent. In addition, Oxelheim (2008) argued that the more information is served by companies, the more information is received by users, which in turn induces the higher possibility that stakeholders become confused; therefore there should be an optimal point to decide

what is sufficient information that is value relevant for users, and not detrimental to the firm.

Table 6.6 The average number of Indonesian sentences in any annual reports

SECTOR	2008	2009	2010	2011	2012	Average (2008-2012)
ALL BANKS	7,437.06	7,319.09	8,496.14	10,447.57	12,018.12	9,494.38
LISTED	10,562.31	10,469.70	12,533.03	16,095.77	19,564.34	13,976.93
UNLISTED	7,489.15	5,443.73	6,261.44	7,880.20	9,141.80	7,069.12
ISLAMIC	7,025.75	6,104.30	6,096.60	7,200.40	7,980.64	6,984.54
NON-ISLAMIC	7,466.97	7,251.27	8,807.77	10,825.15	12,495.67	9,754.71

Source: adopted from SPSS

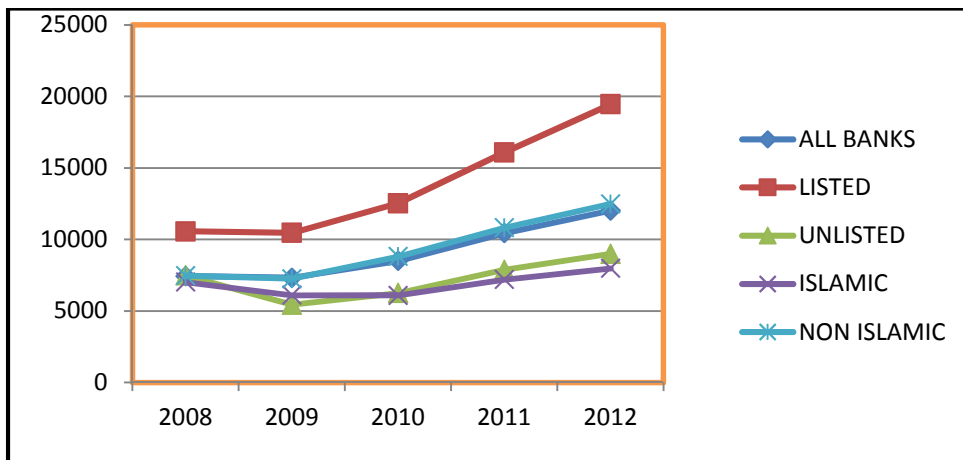

Figure 6.2 The average number of Indonesian sentences in any annual reports

The bank known as Niaga had the highest number of sentences in 2009 and 2011 with 29,200 and 39,554 sentences respectively. In 2010 and 2012, the position was taken by BII with 39,599 and 43,705 sentences respectively. Fama had the lowest number of total sentences in 2009 (373 sentences) and 2010 (348 sentences), while in 2011 and 2012 this was achieved by Ina (736 sentences) and Swadesi (61 sentences).

Table 6.7 The lowest and the highest number of Indonesian sentences in all annual reports

Year	Sector	N (=413)	Indonesian sentences				SD
			The lowest		The highest		
			Bank	Number	Bank	Number	
2008	All	59	BPD BALI	269	NIAGA	41,818	6,861.18
	Listed	27	HIMPUNAN SAUDARA	1,083	NIAGA	41,818	8,171.45
	Unlisted	32	BPD BALI	269	BPD SUMATRA BRT	12,727	4,048.45
	Islamic	4	BUKOPIN SYARIAH	3,970	MUAMALAT	12,222	4,123.95
	NonIslamic	55	BPD BALI	269	NIAGA	41,818	7,043.06
2009	All	67	FAMA	373	NIAGA	29,200	6,120.19
	Listed	25	BRI	704	NIAGA	29,200	7,303.52
	Unlisted	42	FAMA	373	BPD.DKI	15,900	4,406.41
	Islamic	5	MANDIRI SYARIAH	2,629	MUAMALAT	12,037	3,533.11
	Non-Islamic	62	FAMA	373	NIAGA	29,200	6,291.08
2010	All	87	FAMA	348	BII	39,599	7,516.77
	Listed	31	BRI	924	BII	39,599	9,035.66
	Unlisted	56	FAMA	348	BPD.DKI	22,214	5,435.60
	Islamic	10	PANIN SYARIAH	719	BNI SYARIAH	10,790	3,687.07
	Non-Islamic	77	FAMA	348	BII	39,599	7,840.31
2011	All	96	INA	736	NIAGA	39,554	8,721.81
	Listed	30	BRI	3,814	NIAGA	39,554	10,407.04
	Unlisted	66	INA	736	BPD.DKI	30,699	6,437.46
	Islamic	10	PANIN SYARIAH	1,591	BRI SYARIAH	16,518	4,366.98
	Non-Islamic	86	INA	736	NIAGA	39,554	10,825.12
2012	All	104	SWADESI	61	BII	43,705	9,550.13
	Listed	31	SWADESI	61	BII	43,705	10,317.25
	Unlisted	73	BPD.SULAWESI TNGGR	162	BPD.SULAWESI SLTN	40,952	7,154.82
	Islamic	11	VICTORIA SYARIAH	577	MUAMALAT	27,992	8,133.61
	Non-Islamic	93	SWADESI	61	BII	43,705	9,630.13

Source: adopted from QSR6

The listed banks had the highest number of Indonesian sentences in every year, while Islamic banks had the lowest (table 6.6). This may have happened because listed banks were listed on the stock exchange, and therefore had to comply with regulations that

obliged them to mandatorily reveal their performance more transparently through financial statement and annual reports to shareholders. In addition, listed banks conducted more complicated transactions and administrations related to their listing on the stock exchange; and had more stakeholders; and were a focus of concern by regulators, shareholders, analysts and the media. This is in line with Cerf (1961) who asserted that listed companies are required to release more information than unlisted firms.

Even though Islamic banks were expected to report more transparently regarding PLS contracts, they were still weak in explaining their performance in their annual reports. This was indicated from the number of sentences they used in their annual reports, which was still lower than the average of all banks (see table 6.6). However, Islamic banks showed a high volition in describing their performance as exhibited by an upward trend in their reporting of risk.

The upwards and downwards trends in the number of sentences in annual reports and the large gap between the banks which had the lowest and the highest number of sentences indicate that the banks had many variations in describing their risk as voluntarily disclosure which is what Lajili and Zeghal (2005) and Mohobbot (2005) mentioned in their research.

In order to compare the average of risk disclosure, it can be seen in table 6.8 and figure 6.3. The average of risk disclosure was counted by the amount of risk keywords divided by the amount of total sentences in a bank's annual report. Risk disclosure of all banks

and each sector in the five years rose but slightly fluctuated. The trend of risk disclosure during the period of research went up, particularly among Islamic banks.

Table 6.8 The average of risk disclosure in any annual reports

	2008	2009	2010	2011	2012	Average (2008-2012)
ALL BANKS	0.0851	0.0914	0.0901	0.0811	0.0956	0.0889
LISTED	0.0708	0.0813	0.0792	0.0701	0.0865	0.0791
UNLISTED	0.0848	0.0933	0.0962	0.0861	0.0984	0.0942
ISLAMIC	0.0581	0.0759	0.0811	0.0779	0.1130	0.0861
NON-ISLAMIC	0.0870	0.0929	0.0913	0.0815	0.0936	0.0892

Source: adopted from SPSS

The average risk disclosure in all banks increased from 2008 to 2009, but then declined over the following two years, and after that went up in 2012. This also happened in listed and non-Islamic banks. Meanwhile, risk disclosure of unlisted and Islamic banks climbed wildly from 2008 to 2010, but dropped in 2011 and continued upward after that. Risk disclosure of unlisted banks was always higher than listed banks in the period 2008 to 2012. While non-Islamic banks had higher risk disclosure than Islamic banks between 2008 and 2011, in 2012 risk disclosure of Islamic banks dramatically grew by 0.0351 from 0.0779 to 0.1130, which made it higher than non-Islamic banks. Even though listed banks had the highest total risk keywords and total sentences, (as indicated in tables 6.4 and 6.6), the risk disclosure was still lower than unlisted banks. At the same time, Islamic banks had lower number of risk keywords, total sentences and risk disclosure compared to non-Islamic banks.

Another feature which stands out in this chart was that in 2011 all the bank sectors that has previously declined at this point inclined sharply. The final point to note is that all bank sectors disclosed more risk in their annual reports.

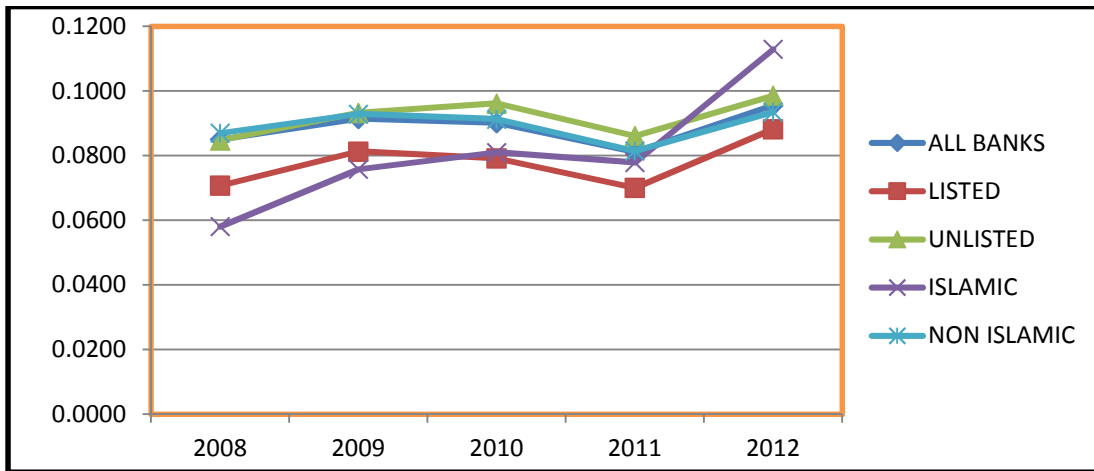

Figure 6.3 The number of risk disclosure in all annual reports in each year

Table 6.9 demonstrates that the gap between the lowest and the highest in terms of risk disclosure was large; not only among unlisted banks but also listed banks. This also happened in Islamic banks and non-Islamic banks. The status of being listed on the stock exchange market or being Islamic banks did not assure that they were willing to explain their performance voluntarily. It can be seen that Windu Kencana in 2008 and Danamon in 2009 had the lowest risk disclosure of listed banks with 0.006 and 0.013 respectively. Meanwhile, BRI Syariah in 2010 and BCA Syariah in 2012 had the lowest risk disclosure with 0.014 and 0.019 respectively.

BRI, a listed and non-Islamic bank, maintained the highest risk disclosure in the three years between 2009 and 2011. The highest risk disclosure in 2008 was Jasa Jakarta as an unlisted and non-Islamic bank, but in 2012 it was taken by UOB bank.

On the whole, what stands out was that the trend of total risk keywords increased. The highest number of total keywords in any annual reports in any year for listed banks was higher than for unlisted banks; in addition, the fewest number of risk keywords in listed banks was higher than for unlisted banks. Meanwhile, non-Islamic banks had a higher number of risk keywords than Islamic banks.

Listed banks had the highest number of risk keywords (table 6.4) and sentences (table 6.6); nevertheless, risk disclosure in listed banks was lower than unlisted banks (table 6.8). However, listed banks have regulations that force them to report their performance more transparently, due to their listing in ISEM; they have more stakeholders than unlisted banks and they are more closely monitored by users. It might be the case that the listed banks tried to explain their performance by writing a large amount of sentences in their annual reports, but they did not explain their risk in more detail.

Islamic banks still had a lower number of risk disclosure than non-Islamic banks; however, Islamic banks showed a rising trend, and in 2012 the average number of risk disclosure increased quite significantly (0.04) from 2011. This has been because the Islamic bank operations were based on a profit and loss sharing basis thereby they were trying to show their performance in order to reassure their stakeholders that these banks were being managed fairly and were obeying Islamic law. Moreover, since 2008 the Bank of Indonesia issued a regulation (number 21) about sharia banking, whereby Islamic

banks were encouraged to promote their existence and to attract stakeholders. Furthermore, Islamic banks are still in emerging market and are attempting to compete with non-Islamic bank in attracting investors.

Moreover, banks might not have been explaining their performance in more detail because they were cautious of the consequences of being transparent. First, by disclosing the company's information, it could expose their strategies to their competitors and even decrease their competitive advantages (Darrough, 1993); Subramanian and Reddy (2012), such as technology information (production process, marketing approach), planning and strategy (new target market, product development), and operational details (sales segments, production costs). Therefore competitors could use disclosure information to be able to produce similar products or services or counter products even better, when they read product development plans in the annual report (Elliott & Jacobson, 1994). In addition, Bhasin (2012) mentioned that even though disclosure in firm information is able to minimise asymmetrical information, it puts a company at risk when it exposes its marketing strategies, research and development or technology.

Second, disclosure leads to increased costs, prices and influences a firm's profit and their performance (Elliott & Jacobson, 1994). Based on agency theory, large banks will report their condition by disclosing more information than smaller banks in order to minimise asymmetric information between managers and users and also to reduce agency costs (Watts & Zimmerman, 1983; Inchausti (1977). Furthermore, Hopkins (1996b) added that a large company will be able to pay financial consultants and analysts to write the company's report in more detail.

Table 6.9 The lowest and the highest number of risk disclosure in each year

Year	Sector	N =413	Risk disclosure				SD
			The lowest		The highest		
			Bank	Number	Bank	Number	
2008	All banks	59	WINDU KENCANA	0.006	JASA JAKARTA	0.368	0.071
	Listed	27	WINDU KENCANA	0.006	HIMPUNAN SAUDARA	0.275	0.064
	Unlisted	32	MUAMALAT	0.020	JASA JAKARTA	0.368	0.076
	Islamic	4	BUKOPIN SYARIAH	0.035	MANDIRI SYARIAH	0.128	0.048
	Non-Islamic	55	WINDU KENCANA	0.006	JASA JAKARTA	0.368	0.073
2009	All banks	67	DANAMON	0.013	BRI	0.425	0.074
	Listed	25	DANAMON	0.013	BRI	0.425	0.081
	Unlisted	42	FAMA	0.021	WOORI	0.285	0.069
	Islamic	5	MEGA SYARIAH	0.041	MANDIRI SYARIAH	0.179	0.058
	Non-Islamic	62	HANA	0.021	BRI	0.425	0.075
2010	All	87	BRI SYARIAH	0.014	BRI	0.462	0.068
	Listed	31	BCA	0.031	BRI	0.462	0.079
	Unlisted	56	BRI SYARIAH	0.014	DIPO	0.304	0.061
	Islamic	10	BRI SYARIAH	0.014	VICTORIA SYARIAH	0.158	0.043
	Non-Islamic	77	BPD.SUMATERA UTR	0.019	BRI	0.462	0.071
2011	All banks	96	BPD NTB	0.012	BRI	0.353	0.049
	Listed	30	EKONOMI RAHARJA	0.027	BRI	0.353	0.057
	Unlisted	66	BPD NTB	0.012	BPD.KALIMANTAN SLTN	0.292	0.045
	Islamic	10	BRI SYARIAH	0.036	PANIN SYARIAH	0.163	0.038
	Non-Islamic	86	BPD NTB	0.012	BRI	0.353	0.051
2012	All banks	104	BCA SYARIAH	0.019	UOB	0.464	0.066
	Listed	31	HIMPUNAN SAUDARA	0.032	BRI	0.384	0.073
	Unlisted	73	BCA SYARIAH	0.019	UOB	0.464	0.067
	Islamic	11	BCA SYARIAH	0.019	MAYBANK SYARIAH	0.113	0.067
	Non-Islamic	93	SINAR HARAPAN BALI	0.028	UOB	0.464	0.069

Source: adopted from QSR6

In addition, banks disclose quality information in annual reports in order to help investors read it more easily and interpret it. The increased trend on the total number of risk

keyword, number of sentences and risk disclosure in annual report due to being supported by the number of regulations that issued by the Indonesian Stock Exchange Market Board and the Bank of Indonesia. Since 1998, the BI has attempted to push banks to report their performance more transparent by issuing circular letter and law regulations. Furthermore, unlisted banks had a higher average of risk disclosure than listed banks, while the average number of risk disclosure of non-Islamic banks was higher than Islamic banks. All in all, risk disclosure in Indonesian banking sector had an upward trend. It signifies that the banks were attempting to report their performance more transparently every year during the research period of 2008 to 2012.

6.5 The Results Of RQ 2: Are There Differences Between The Extent Of Risk Disclosure Practice Between Listed Banks And Unlisted Banks, And Between Islamic Banks And Non-Islamic Banks?

This part describes the differences in the extent of risk disclosure between listed and unlisted banks, and Islamic and non-Islamic banks.

6.5.1 The Differences between Listed and Unlisted Banks

Listing on the stock exchange market is a complex process as well as an expensive one. The consequences for listed companies are: first, listed companies are obliged to make periodical reports to regulators while facing high pressure from regulators such as the Capital Market Supervisory Agency. Second, because they are publicly-traded companies they have to be transparent in showing their performance; hence their competitors have easy access to their data and management strategies. Third, listed companies are required to maintain their relationship with investors by giving progress

reports in a timely, accurate and transparent manner. It can therefore be assumed that listed companies are likely to have more transparent annual reports compared to unlisted firms. Meanwhile, Brounen et al. (2007) mentioned that unlisted companies had an absence of transparency.

Table 6.10 shows that the mean of the delta of risk disclosure of listed banks is 0.0045, while the mean of the delta of risk disclosure of unlisted banks is 0.0067. This result indicates that the mean of the deltas of risk disclosure of unlisted banks is higher than listed banks. This is also supported by the data in table 6.8, which shows that unlisted banks had higher risk disclosure than listed banks in five periods, and that the growth shows a strong upward trend.

Table 6.10 Listed and Unlisted Banks Group Statistics

VARIABLES	SECTOR	N	Mean	Min.	Max.	SD
ASSETS	Unlisted	196	0.2292	-0.90	6.21	0.54297
	Listed	116	1.3751	-2.11	8.73	2.04523
LDR	Unlisted	196	0.1070	-1.56	3.33	0.49546
	Listed	116	0.0010	-0.86	0.86	0.22247
ROE	Unlisted	196	0.0197	-0.71	0.99	0.14439
	Listed	116	0.0294	-3.63	4.55	0.56325
LEVERAGE	Unlisted	196	0.0567	-0.79	1.06	0.26494
	Listed	116	-0.2032	-0.91	0.90	0.39321
EARNINGSREINV	Unlisted	196	0.0851	-3.92	3.05	0.54528
	Listed	116	-0.0148	-2.88	3.29	0.43726
RISKDISC	Unlisted	196	0.0067	-0.33	0.38	0.06947
	Listed	116	0.0045	-0.21	0.22	0.04749
FIRMVALUE	Unlisted	196	0.3027	-5.69	9.55	1.35563
	Listed	116	19.3341	-1,354	4,490	441.28961

Sources: adopted form SPSS

Listed banks are constrained by regulation, i.e. the Indonesian Stock Exchange Market Board Circular letter number SE-02/PM/2002 concerning Guidelines for Preparation of Financial Statements for Public Company. They are also noticed, monitored and subject to scrutiny not only by the public but also regulators and the mass media. Moreover,

Branco and Rodrigues (2006) added that listed companies are expected to disclose more in reporting their performance than unlisted banks.

Aljifri et al. (2014) and Wallace et al. (1994) stated that listed companies are more transparent than unlisted firms, and have a significantly positive relationship with the extent of disclosure. In addition, listed companies voluntarily disclose more of their performance in order to attract investors and raise funds, and also try to decrease the cost of capital and asymmetric information between stakeholders and managers. However, this research shows that listed banks displayed lower risk transparency than unlisted banks (table 6.8). This study represents a contradictory result through its finding that unlisted banks' annual reports explained risk disclosure to a greater extent than listed banks. It might be that some companies were reluctant to explain their performance in more detail because the managers were concerned about the consequences of disclosure. In addition, the large unlisted banks reported their risk in more detail because based on agency theory, to minimise asymmetrical information between managers and users and also to reduce agency costs, large companies report their condition by disclosing more information than smaller companies (Watts & Zimmerman, 1983; Inchausti (1997). Furthermore, a large company is more likely to be able to pay financial consultants and analysts to write the company's report in more detail.

The Levene's test of the delta of risk disclosure between listed and unlisted is shown in table 6.11. Levene's test shows that $p \text{ value} = 0.005 < 0.05$, which signifies that the variance of the delta of risk disclosure is heterogeneous. This indicates the variance of data was similar and the data were scattered far from the mean. Variance represents the average squared deviations between a group of observations and their respective mean.

Nevertheless, p value (2 tailed) of t test is $0.740 > 0.05$, shows that the delta of risk disclosure in the listed and unlisted banks was the same. This is possibly because the regulations of the BI and ISEM pushed banks to report their performance in more detail. Moreover, other factors could influence the banks to report the risk more transparently as indicated in Elshandidy et al's (2008) results. They found that corporate governance such as board size, proportion of total non-executive directors and independent non-exclusive directors could influence managers to disclose the risk.

Other data for indicating the differences between listed banks and unlisted banks is as follows. First, table 6.11 exhibits that the delta of firm size (assets) has a significant Levene's test ($p \text{ value} = 0 < 0.05$). It means that variance in the delta of firm size was heterogeneous. Moreover, the p value (2 tailed) is $0 < 0.05$, which signifies that the differences of delta of assets between listed and unlisted banks was significant. Furthermore, the mean of the listed banks' delta of assets is higher than unlisted banks.

This shows that listed banks had higher assets than unlisted banks. Theory suggests that listed firms find it easier to gather funds from external sources and access banks than unlisted firms. With their funds they can create more profit and increase their assets.

Moreover, becoming a public company in Indonesia is expensive. The company must fulfil a range of requirements, such as having net tangible assets of Rp.100,000,000,000 for a main board listing and Rp.5,000,000,000 for the development board. The main board is for companies operating on a large scale and prospective companies must have track records. The development board is for prospective companies which have not been able to be fulfil the requirements of the main board, but they have posted profit

(www.idx.co.id). This means that the requirements can be fulfilled by a company that has a large assets.

Second, the liquidity measured by Loan to Deposit Ratio (LDR) had a Levene's test (p value=0.001) < 0.05. This signifies that the variance of the delta of LDR was heterogeneous. Moreover, p value (2 tailed) is $0.010 < 0.05$, denotes that the delta of LDR in the listed and unlisted banks was different.

Heffernan (2005) asserted that a bank is an intermediary institution whose main functions are to receive money as liabilities from creditors or depositors and from investors as capital, and further to lend money as assets to debtors or borrowers. Furthermore, it is common for banks to have a high LDR because they distribute their funds in the form of loans as one of their main functions and because of the Bank of Indonesia regulations, which state that in order to make safe lending, banks must distribute their source of funds into credit with a LDR between 78% - 100%. The cycles of allocation of funds can be seen in figure 4.3.

The mean of delta LDR in unlisted banks (0.1070) was higher than listed banks (0.001), as shown in table 6.10. The Levene's test in table 6.11 also demonstrates that LDR in listed and unlisted banks was different. This indicates that in the unlisted banks the proportion of loans distributed from third party funds was higher than in listed banks. The results demonstrate that unlisted banks tried to distribute a higher percentage of their third party funds than listed banks. It might be that unlisted banks were attempting to make higher profits by lending to more risky projects while listed banks were able to achieve profit from other ways, such as investing their funds in reliably profitable

businesses. Moreover, listed companies find it easier to obtain funds from external sources hence they have less of third source of funds, and distribute it into good portfolios. Along with that listed banks have a low LDR.

Table 6.11 shows that the variance of the delta of ROE in listed and unlisted banks was homogeneous. The ROE had p value (2 tailed) t test 0.820, indicating that the delta of ROE in the listed and unlisted banks was the same. However, based on table 6.10 the average of delta of ROE in the listed banks was higher than unlisted banks.

This is in line with Capasso et al. (2005) who highlighted that listed companies could make bigger profits than unlisted firms. It makes sense that listed banks had a higher profitability ratio than unlisted banks. Listed banks were attempting to achieve high profits in order to pay dividends to satisfy their shareholders. Therefore, by achieving a high profit they were able to increase their share price.

The Indonesia Stock Exchange guideline book mentioned that it is easier for listed banks to get new funding resources from external sources and use the funds for further firm and market expansion. Capasso et al. (2005) asserted that by selling shares the cost of funds is cheaper than raising funds from debt, which means the bank's leverage ratio can be minimised. Listed companies with low leverage ratio can increase their profit. As shown in table 6.10, listed banks had a smaller mean leverage ratio than unlisted. This explains why listed banks were able to achieve higher profit than unlisted ones: because they had smaller leverage than unlisted banks.

Moreover, the delta of leverage between listed and unlisted banks was different. It is shown in table 6.11 that p value (0) < 0.05, which indicates that the variance of leverage

was heterogeneous, and the p value 2 tailed is $0 < 0.05$. This shows that the delta of leverage of listed banks and unlisted banks was different. Even though listed banks still attempted to attract funds from depositors, listed banks were more focused on collecting funds from external sources, such as issuing shares on stock markets. On the other hand, the main sources in unlisted banks are from debts (third party), hence they have higher leverage. This is in line with Schoubben and Rulle (2004) who claimed that unlisted companies carry higher debt than listed companies. This corroborates the findings of a previous researcher, Capasso et al. (2005), who also mentioned that public companies tend have lower leverage compared to unlisted firms. The listed firms are more dependent on external sources, hence they have a small leverage ratio compared to unlisted firms; meanwhile, unlisted companies depend on more internal sources: in doing so they have a higher leverage.

Furthermore, the variance of delta of earnings reinvestment between listed and unlisted banks was heterogeneous. This can be explained by data in tables 6.10 and 6.11, which show that p value $0.017 < 0.05$, and the p value (2 tailed) is $0.077 > 0.05$; therefore, the delta of earnings reinvestment in the listed banks and unlisted banks was the same.

This shows that unlisted banks preferred to reinvest their earnings and tended not to distribute dividends to their shareholders. This may have been because unlisted banks needed funds to develop their business. Moreover, table 6.11 shows that the delta of earnings reinvestment between listed and unlisted banks was the same.

The Clientele Effect states that the group (clientele) of shareholders has different preferences on dividend policy. The theory maintains that a group of shareholders who

need income now prefer a high dividend payout ratio. On the other hand a group of shareholders who do not need money now prefer to retain the company's net profit for reinvestment. This result is in accordance with Bodie et al. (2011) who stated that if a company that prefers to reinvest earnings has an earnings reinvestment policy that prefers to reinvest earnings, initially investors will receive small earnings, but in the long-term investors will get greater benefits by receiving high dividends. Conversely, companies which distribute large dividends initially have low reinvestment opportunities and in the future dividend growth rates will be low.

Eventually, even though the mean of the delta of firm value of listed banks was higher than for unlisted banks, as shown in table 6.10, the delta of firm value between listed and unlisted banks did not show a difference. Moreover, in table 6.11, p value was $0.014 < 0.05$ (heterogeneous) and p value (2 tailed) was $0.643 > 0.05$ which indicates that the delta of firm value of listed and unlisted banks was the same. There was no difference between the delta of firm value in listed and unlisted banks during the research period.

This result is supported by Capasso et al. (2005) who demonstrated that listed companies had higher firm value than unlisted companies. When listed companies enjoy good financial performance, it has the impact of boosting their stock price, creating a good image and prestige, and finally it will increase the value of the company. In addition, when a company has good performance and then reports their information completely, the users can use the information and thus the information is value relevant for stakeholders: this will ultimately increase firm value.

To sum up, the mean of delta: asset, ROE and firm value of listed banks were higher than unlisted banks. The following characteristics: firm size; liquidity; and leverage, were significantly different between listed and unlisted banks. Meanwhile, the following characteristics: profitability; earnings reinvestment; risk disclosure; and firm value, were the same.

Table 6.11: Listed and Unlisted Banks - Independent Test

Variables	Levene's Test for Equality of Variances		t-test for Equality of Means		
	F	Sig.	T	Sig. (2-tailed)	The differences between listed and unlisted banks
ASSETS	128.775	0.000	-5.912	0.000	Different
LDR	12.297	0.001	2.585	0.010	Different
ROE	3.453	0.064	-0.228	0.820	The same
LEVERAGE	53.003	0.000	6.320	0.000	Different
EARNINGSREINV	5.738	0.017	1.776	0.077	The same
RISKDISC	8.060	0.005	0.332	0.740	The same
FIRMVALUE	6.082	0.014	-0.464	0.643	The same

Sources: adopted form SPSS

6.5.2 The differences between Islamic banks and non-Islamic banks

This subchapter explains the statistical results of the second research question about the differences between Islamic banks and non-Islamic banks.

Islamic banks are still an emerging market, and deal with risks that are different from non-Islamic banks; furthermore, they must obey Islamic law, thereby Islamic banks may be expected to make more disclosure than non-Islamic banks. Ariffin (2005) asserted that Islamic banks are required by their supervisors to be transparent about risk, and transparency in Islamic banks is more crucial compared to conventional banks due to

Islamic banks employing profit and loss sharing contracts. He also mentioned that Islamic banks are still lacking in terms of the transparency with which they release risk information, meaning that shareholders are not properly able to monitor the banks' risk profile.

The statistical results of the differences between Islamic banks and non-Islamic banks are demonstrated in table 6.12 and table 6.13. Table 6.12 shows that the mean of the delta of risk disclosure in Islamic banks was higher than non-Islamic banks. Moreover, p value was $0.620 > 0.05$, meaning that the data is homogeneous, while p value (2 tailed) was $0.386 > 0.05$, meaning that there was no difference in the delta in risk disclosure between Islamic banks and non-Islamic banks.

This may be accounted for by the fact that since 2008, the Bank of Indonesia has been trying to develop Islamic banks and to support national development, aiming to improve overall economic conditions by issuing Republic of Indonesia law number 21/2008 about sharia banking. Along with that, Islamic banks have tried to disclose their performance in more detail in their annual reports than non-Islamic banks in order to attract customers and to gain access to more markets.

Moreover, Ariffin (2005) and Baydoun and Willett (2000) asserted that because Islamic banks employ profit and loss sharing, it is necessary that they be credible, have an ethical responsibility and comply with sharia law; hence they report more transparently. In addition, in order to minimise misperception and mistaken interpretation, stakeholders should find it easy to understand the banks' performance, meaning that risk disclosure in Islamic banks is likely to be more important than in non-Islamic banks.

The mean of the delta of assets of Islamic banks was lower than non-Islamic banks. The delta in firm size (assets) had a p value= $0.011 < 0.05$, meaning that variance of firm size was heterogenous, as shown in table 6.13. Moreover, the p value (2 tailed) $0.008 < 0.05$ means that the difference between the delta of assets in Islamic banks and non-Islamic banks was significant.

Due to having only been established since 1998, it might be that Islamic banks in Indonesia were starting to develop and searching for markets that had been dominated by non-Islamic banks before. Along with that it is possible that Islamic banks still had lower assets than non-Islamic banks. On the other side, non-Islamic banks have been established longer than Islamic banks, therefore they may be expected to have higher assets than Islamic banks.

Moreover, the liquidity, measured by the Loan to Deposit Ratio (LDR), had a Levene's test (p value= $0.740 > 0.05$). This means the variance in the delta of LDR was homogenous. The result of p value (2 tailed) $0.365 > 0.05$, meaning that the delta of LDR in the Islamic and non-Islamic banks had no difference. When the financial crisis happened in 2008, Islamic banks showed a better performance in capital asset ratio and had a higher liquidity reserve compared to non-Islamic banks. Moreover, Beck et al. (2010) argued that Islamic banks had a lower finance to deposit ratio than non-Islamic banks. Table 6.12 shows that Islamic banks had a smaller mean of the delta of FDR than non-Islamic banks. However, the Levene's test exhibited no difference between the delta of FDR in Islamic and non-Islamic banks. This might have happened because Islamic banks had recently been established, hence they did not have the power to compete with non-Islamic banks to collect and lend funds. Moreover, Islamic banks were not well

understood by the public, along with that they were trying to seek new markets for distributing their funds. Islamic banks also faced the challenge of acquainting the market with their products and services. This result is not in line with Bokpin (2013) who mentioned that the means of LDR in Islamic and non-Islamic banks in Malaysia were the same.

Table 6.12 Islamic and Non-Islamic banks - Group Statistics

Variables	SECTOR	N	Mean	Min,	Max.	SD
ASSETS	Non-Islamic	285	0.6830	-2.11	8.73	1.48593
	Islamic	27	0.3617	0.02	1.62	0.42021
LDR	Non-Islamic	285	0.0742	-1.56	3.33	0.42334
	Islamic	27	-0.0022	-0.97	0.93	0.35821
ROE	Non-Islamic	285	0.0249	-3.63	4.55	0.36993
	Islamic	27	0.0071	-0.71	0.05	0.25444
LEVERAGE	Non-Islamic	285	-0.0470	-0.91	1.06	0.34171
	Islamic	27	0.0341	-0.79	0.86	0.34344
EARNINGREIV	Non-Islamic	285	0.0451	-3.92	3.29	0.48644
	Islamic	27	0.0775	-1.54	2.99	0.71969
RISKDISC	Non-Islamic	285	0.0049	-0.33	0.38	0.06331
	Islamic	27	0.0158	-0.08	0.16	0.04784
FIRMVALUE	Non-Islamic	285	8.0168	-1354	4,490	280.96926
	Islamic	27	0.6407	-1.05	9.55	1.87480

Source: adopted from SPSS

Furthermore, the profitability, which was measured by Return on Equity (ROE), shows that in the Levene's test (p value = 0.321) > 0.05. This means that the variance of the delta of ROE in Islamic and non-Islamic banks was heterogeneous. The ROE had a p value (2 tailed) 0.808, meaning that the delta of ROE in the Islamic banks and non-Islamic banks was the same. This result was not in accordance with Mercer (2004) who conducted their research in the countries of the Gulf Cooperation Council and asserted

that in the period before the crisis (2006-2007) and during the crisis (2008-2009), overall Islamic banks had better performance, particularly in ROA and liquidity.

The relative success of non-Islamic banks in producing higher profit may be due to the fact that the Islamic banks were still in an emerging market and trying to attract more customers. Moreover, non-Islamic banks had a longer history, bigger markets and were more popular. On the other hand, Islamic banks in Indonesia had just been established a few years previously and were still seeking markets and customers: in this context it can be understood that Islamic banks made lower profits than non-Islamic banks. Moreover, it is reasonable that Islamic banks had a lower profit than non-Islamic banks, because Islamic banks had lower assets and FDR and a higher leverage than non-Islamic banks, as explained before. With their limited assets and a small FDR and a high leverage, Islamic banks were not able to distribute their funds to as many customers, hence they had a smaller FDR; therefore, they could not make more profit. In addition, by having a high leverage ratio, this decreased their profit. In addition, the delta of leverage between Islamic and non-Islamic banks was the same. Table 6.13 shows that the p value was $0.675 > 0.05$, meaning that the leverage was heterogeneous, while t test 2 tailed was $0.240 > 0.05$. This indicates that non-Islamic banks had the same delta of leverage as Islamic banks.

This result is not in line with Bokpin (2013) who asserted that Islamic banks had a significant difference in debt to total assets compared with conventional banks, even though the mean of leverage in Islamic banks was lower than non-Islamic banks. This may have happened because the Islamic banks' main sources of funds are from third parties as liabilities, which were then allocated to investment, sale and purchase

transactions, and leasing. Nevertheless, due to Islamic banks having just been established, they were trying to enter new markets and were thus selling to their potential source of funds. Along with that, the leverage in Islamic banks was higher than in non-Islamic banks.

Table 6.13 Islamic and Non-Islamic banks - Independent Test Samples

Variables	Levene's Test for Equality of Variances		t-test for Equality of Means		
	F	Sig.	T	Sig. (2-tailed)	The differences between Islamic and non-Islamic banks
ASSETS	6.583	0.011	2.688	0.008	Different
LDR	0.111	0.740	0.907	0.365	The same
ROE	0.988	0.321	0.243	0.808	The same
LEVERAGE	0.177	0.675	-1.178	0.240	The same
EARNINGSREINV	1.903	0.169	-0.315	0.753	The same
RISKDISC	0.247	0.620	-0.869	0.386	The same
FIRMVALUE	0.322	0.571	0.136	0.892	The same

Source: adopted from SPSS

Furthermore, the variance of the delta in earnings reinvestment between Islamic and non-Islamic banks was homogeneous. Table 6.13 shows that p value was $0.169 > 0.05$. The earnings reinvestment had t test (2 tailed) $0.753 > 0.05$, meaning that the delta of earnings reinvestment in the Islamic banks and non-Islamic banks was the same.

Roden and Stripling (1997) mentioned that a decision to make dividend payments policy is important concerning whether cash flow will be paid to investors or will be retained for reinvestment. A dividend reinvestment plan means that the firms will not pay dividends but the company will reinvest the funds. The mean of the delta of earnings reinvestment

in Islamic banks was higher than in non-Islamic banks (table 6.12). Levene's test shows that the delta of earnings reinvestment between Islamic and non-Islamic banks was the same. This suggests that Islamic banks preferred to reinvest their profit than distribute dividends to their shareholders. It is possible that Islamic banks preferred to reinvest their earnings because they were still at a growth level; hence they need more funds to make them larger and stronger.

The delta of firm value between Islamic banks and non-Islamic banks was the same, as can be seen in table 6.13; moreover, the p value was $0.571 > 0.05$ (homogeneous) and t test with 2 tailed is $0.892 > 0.05$. This might have been because a proportion of non-Islamic banks were listed banks, and due to this their firm value increased due to the share price increasing on the stock market. Moreover, non-Islamic banks had higher assets and profit that boosted their firm value.

To sum up, the mean of delta leverage, earnings reinvestment and risk disclosure in Islamic banks were higher than non-Islamic banks. The mean of delta assets, LDR, ROE and firm value in non-Islamic banks were higher than Islamic banks. The delta of assets was significantly different between Islamic and non-Islamic banks.

6.6 The Results of RQ 3: What factors affect a bank's decision to disclose risk?

In order to answer research question number three, this sub chapter will be divided into five parts, namely: all banks, listed, unlisted, Islamic and non-Islamic banks. The first statistical model will be examined for explaining the effect of the delta of firm characteristics on the delta of risk disclosure and answers the hypotheses.

6.6.1 RQ 3.1: The factors affecting banks' decisions to disclose risk in all banks

Tables 6.14 to 6.24 demonstrate the results of correlation and regression tests between the delta of firm characteristics and the delta of risk disclosure and the delta of firm value in all banks. Each hypothesis will be explained as follows:

The association between the delta of risk disclosure and the delta of firm size in all banks

Table 6.14 shows that the p significance in Pearson correlation between the delta of assets and the delta of risk disclosure was $0.215 > 5\%$ and this indicates that the delta of assets did not have a relationship with the delta of risk disclosure. The result is also supported by p value being higher than 0.05 in table 6.15, meaning that the delta of firm size did not have a positive correlation with the delta of risk disclosure. Therefore, this study rejects the first hypothesis (H1) and concludes that there is no association between delta of risk disclosure and delta of firm size in all banks.

Agency theory suggests that large companies with high assets will disclose more in order to minimise asymmetrical information between managers and users. Furthermore, signalling theory also asserts that large banks report more transparently in order to send good signals to users to reassure that with their high assets, larger banks are able to cover their risks better than small banks. In addition, larger firms will be followed by an increasing number of stakeholders. Amran, Bin, and Hassan (2009) mentioned that stakeholders, including public and government, encourage large companies to report their risks more transparently and explain how they cope with and manage their risks.

Moreover, stakeholder theory asserts that bigger companies have more stakeholders and an obligation under regulations to reveal their performance transparently in order to fulfil stakeholders' needs. In addition, Linsley & Shrides (2006) asserted that larger companies have more complex transactions and undertake more activities. Because of this the public will pay more attention; in addition the bank will be subject to greater monitoring by government, regulators, media and the public.

The first hypothesis is that there was a positive association between firm size and risk disclosure; nevertheless, table 6.14 shows p significant is $0.215 > 5\%$ and this indicates that the delta of assets did not have a relationship with the delta of risk disclosure. The result is also supported by p value in table 6.15 that is higher than 0.05, meaning that individually the delta of firm size did not affect the delta of risk disclosure. This indicates that banks in Indonesia were not transparent in revealing their risks in their annual reports, based on the delta of assets. Therefore this study rejects the first hypothesis (H1) and concludes that there is no association between delta of risk disclosure and delta of firm size. Even though they were large banks, they were still reluctant to explain their risk transparently. They may have been considering other factors when they reported their risk in more detail. In this respect, this study is not in line with agency, signalling and stakeholders theories; however, this result is consistent with Agyei-Mensah (2012); Aljifri and Hussainey (2007); Mathuva (2012); Rajab and Handley-Schachler (2009); Popova et al. (2013) who all agreed that firm size has an insignificant association with risk disclosure.

The association between the delta of risk disclosure and the delta of liquidity in all banks

Table 6.14 shows that the p value of the individual relationship between the delta of risk disclosure and the delta of LDR was 0.017 and therefore smaller than 0.05. This means that the association between the delta of risk disclosure and the delta of liquidity was significantly positive. Nevertheless, the significant relationship of the delta of LDR and risk disclosure cannot be demonstrated due to p value (0.092) being higher than 0.05, as shown in table 6.15. Therefore, the second hypothesis (H2) that supposes a positive association between the delta of risk disclosure and the delta of liquidity is rejected.

Table 6.14 Pearson's correlation between firm characteristics and risk disclosure and firm value in all banks

	Assets	LDR	ROE	Leverage	Earnings Reinv.	Risk Disc.
Assets	1					
LDR	0.056 (0.160)	1				
ROE	-0.007 (0.453)	0.030 (0.297)	1			
Leverage	-0.149** (0.004)	0.260** (0.000)	0.113* (0.023)	1		
Earnings Reinv.	0.071 (0.106)	0.155** (0.003)	0.057 (0.157)	0.157** (0.003)	1	
Risk Disc.	0.045 (0.215)	0.120* (0.017)	-0.009 (0.440)	0.088 (0.061)	0.020 (0.361)	1

P-values are given in parentheses. The number of observations is 312. ** Correlation is significant at the 0.01 level (1- tailed). * Correlation is significant at 0.05 level (1-tailed)

Liquidity demonstrates a bank's ability to repay short term debts or ability to provide money when depositors seek to withdraw their deposits. In addition, liquidity is one of the ratios that can be used for predicting bankruptcy. For banks with a high LDR, larger than the ratio standard, this implies that such banks face high risk because as debtors they might not be able to repay their debts.

Table 6.15 Summary of the Result of OLS Regression Risk Disclosure in all banks

Variables	s		t	Sig t	Hypothesis
ASSETS	0.050		0.875	0.382	H1:Rejected
LDR	0.100		1.693	0.092	H2:Rejected
ROE	-0.019		-0.332	0.740	H3:Rejected
LEVERAGE	0.073		1.204	0.229	H4:Rejected
EARNINGS REINVESTMENT	-0.009		-0.158	0.874	H5:Rejected
Adjusted R square = 0.005 F= 1.289 Ftable (5,306) = 2.24 Fsig.= 0.268 DW = 2.390					H6:Rejected

Source: adopted from SPSS

Signalling theory mentions that firms with high liquidity will disclose more and show better signals than firms with smaller liquidity ratios. Marshall and Weetman (2007) found a significant relationship between disclosure and liquidity in UK firms. Table 6.14 shows that the p value of individual relationship between the delta of risk disclosure and the delta of LDR was 0.017, and therefore smaller than 0.05. This means that the association between the delta of risk disclosure and the delta of liquidity was significantly positive. A statistically positive relationship between the delta of LDR and the delta of risk disclosure means that banks disclosed a lot of detail in terms of their LDR. Nevertheless, the impact of LDR on risk disclosure individually cannot be demonstrated because p value (0.092) in table 6.15 is higher than 0.05. This may have happened because lending credit is the main function of a bank and they did indeed obey the regulation to maintain LDR between 78-100%. Hence, banks did not reveal their risk performance merely based on the delta of LDR.

The result is not in accordance with signalling theory but in line with Elzahar and Hussainey (2012) and Agyei-Mensah (2012), who revealed that liquidity has an insignificant correlation with risk disclosure. Therefore, the second hypothesis (H2) that

supposes a positive association between the delta of risk disclosure and the delta of liquidity is rejected.

The association between the delta of risk disclosure and the delta of profitability in all banks

The relationship between the delta of risk disclosure and the delta of profitability can be seen in table 6.14. The p value was 0.440 which means there was no relationship between the delta of risk disclosure and the delta of profitability. The relationship of delta of ROE and the delta of risk disclosure also could not be proven because p value was more than 0.05, as shown in table 6.15. As a result, the third hypothesis (H3) that supposes a positive association between the delta of risk disclosure and the delta of profitability is rejected.

The association between the delta of risk disclosure and the delta of leverage in all banks

The result of the relationship between the delta of risk disclosure and the delta of leverage had a p value 0.061, higher than 5% which shows the association between the delta of risk disclosure and the delta of leverage is insignificant. This study also could not prove that the delta of leverage has a relationship with the delta of risk disclosure, as signified in table 6.15 which shows that p value was 0.229, which is higher than 0.05. Therefore, the fourth hypothesis (H4) that supposes a positive association between the delta of risk disclosure and the delta of leverage is rejected. A bank is a financial institution with a high level of debt and a high level of leverage because the main sources of bank funds are from depositors and creditors. Because of this, it is normal for banks to have high

leverage. Ramadan (2012) mentioned that debts could benefit a company in terms of earning profit and creating opportunities for investments; on the other hand it is harmful and risky for the firm when it is not able to pay debts back plus the interest. The lenders can claim bankruptcy if the bank is not able to repay the debts. Doubt over a bank's ability to meet its debt obligations will lead investors to have a negative image, and as the consequence decreases firm share price in listed companies.

Firms with high debt equity may have more incentive to disclose financial information to suit the needs of their creditors. Therefore, banks are expected to be more closely monitored by financial supervisors, which drives them to disclose their risk performance. Furthermore, according to Fama and Miller (1972), for companies with high leverage, such firms will try to describe their condition in more detail to creditors in order to reassure that they are able to repay their debts.

The result of the relationship between the delta of risk disclosure and the delta of leverage has p value of 0.061, which is higher than 5% and indicates that the association between the delta of risk disclosure and the delta of leverage is insignificant. This study was also not able to prove that the delta of leverage influences the delta of risk disclosure, as signified in table 6.15 that p value is 0.229, which is higher than 0.05. By contrast, agency theory suggests that firms with high leverage will voluntarily report in more detail in order to satisfy creditors.

This result indicates that banks were reluctant to reveal their risk performance in more detail based on the delta of leverage. This result is in accordance with previous researchers, namely Elzahar and Hussainey (2012); Linsley and Shrivs (2006); Rajab

and Handley-Schachler (2009) who concluded that there was an insignificant relationship between disclosure and leverage. Therefore, the fourth hypothesis (H4) that supposes a positive association between the delta of risk disclosure and the delta of leverage is rejected.

The association between the delta of risk disclosure and the delta of earnings reinvestment in all banks

Table 6.14 describes the result of the association between the delta of risk disclosure and delta of earnings reinvestment individually, which shows that p value was $0.361 > 0.05$. This reflects that the delta of risk disclosure had an insignificant relationship with the delta of earnings reinvestment. This research did not find any association between the delta of earnings reinvestment and the delta of risk disclosure because p value was more than 5%, as represented in table 6.15. Therefore, the fifth hypothesis (H5) that supposes a positive association between the delta of risk disclosure and the delta of earnings reinvestment is rejected.

A dividend reinvestment plan means that firms do not pay dividends but the company reinvests its funds to increase its capital or to expand its business. Firms are able to reinvest their earnings into simple and low risk investments, for example: buying equipment, maintaining existing machinery, expanding their company or business, or paying their debts. In addition, Roden and Stripling (1997) mentioned that a decision over dividend payments policy is an important issue concerning whether cash flow will be paid to investors or will be retained for reinvestment.

Discussing dividends and earnings reinvestments is still debated difficult decision for companies, who perceive giving high dividends (low earnings reinvestments) to be good for shareholders and the company; on the other hand, paying small dividends (high earnings reinvestments) is also a good decision, as explained by The Clientele Effect and Bodie et al. (2011).

Table 6.14 describes the result of the association between the delta of risk disclosure and delta of earnings reinvestment individually, in which the p value is $0.361 > 0.05$. This reflects that risk disclosure has an insignificant relationship with earnings reinvestment. This research also could not find the impact of earnings reinvestment on risk disclosure because p value was more than 5%, as represented in table 6.15. This result signifies that the change of earnings reinvestment did not support banks to report risk more transparently to their investors. Therefore, the fifth hypothesis (H5) that supposes a positive association between the delta of risk disclosure and the delta of earnings reinvestment is rejected.

There is an association between delta of firm characteristics and the delta of risk disclosure in all banks

Table 6.15 shows that $F (1.289) < F$ table and meaning that the delta of firm characteristics, aggregated with the delta of firm size, liquidity, profitability, leverage, and earnings reinvestment, did not have a significant relationship with the delta of risk disclosure. Moreover, adjusted R square for model 1 was only 0.005. This means the delta of firm size (assets), liquidity (LDR), profitability (ROE), leverage, and earnings

reinvestment (b) cannot explain the delta of risk disclosure. Therefore, the sixth hypothesis (H6) is rejected.

Banks disclose risk more fully because they want to explain how they have managed their risks well and their willingness to send good signals to stakeholders regarding how stable the bank is, their capability to reserve funds for covering short term and long term liabilities, how the funds have been invested and how this provides high dividends to investors.

Table 6.15 shows that $F (1.289) < F \text{ table}$ and p value is 0.268, meaning that the aggregate delta of firm characteristics did not have an association with the delta of risk disclosure. Moreover, adjusted R square for model 1 was only 0.005. This means the delta of bank size (assets), liquidity (LDR), profitability (ROE), leverage, and earnings reinvestment (b) were not able to explain the delta of risk disclosure. In other words, model 1 was not fit for explaining the relationship between the delta of firm characteristics and the delta of risk disclosure. As a result, the sixth hypothesis (H6) is rejected.

This result indicates that in reporting their risks in annual reports, banks were affected by other variables that were not tested in this research. Banks might have many considerations for making their performance more transparent, since disclosure of their performance has some consequences. By reporting more transparently, competitors are not only able to read a bank's strategies, but also imitate its products. Moreover, Elliott and Jacobson (1994) argued that when companies make their report more detailed, the costs of reporting increases, and this influences product price, meaning that profit decreases.

To sum up, this study was not able to show the relationship between the delta of firm characteristics and the delta of risk disclosure supposed in Model 1. In addition, the relationship between the delta of risk disclosure and the delta of firm characteristics only had R square 0.005 and F (1.289) insignificant. This means neither the delta of size, liquidity, profitability, leverage, nor earnings reinvestment explained and influenced the delta of risk disclosure. Therefore, Model 1 in this study was not fit for explaining the factor which affected risk disclosure. For those reasons, the sixth hypothesis was rejected.¹

6.6.2 RQ 3.2: The factors affecting banks' decisions to disclose risks in listed banks

This subchapter explains that factors affecting a bank's decision to disclose risks and factors affecting a firm value in listed banks, consisting of two models. The statistical correlation and regression results for the listed banks are summarised in tables 6.16 and 6.17. Each hypothesis will be explained as follows:

The association between the delta of risk disclosure and the delta of firm size in listed banks

The Pearson's correlation shows an insignificant association between the delta of risk disclosure and the delta of assets in listed banks, as shown in table 6.16. The multiple

¹ I also tested the association between the delta of risk disclosure and the delta of firm characteristics by employing lagged (first: the increased of the delta of firm characteristics previous year and the delta of risk disclosure in the following year. Second: the delta of firm characteristics previous year and risk disclosure in the following year). The results showed that there is an insignificant association between those variables.

regression result also did not show an association between the delta of firm size and the delta of risk disclosure. Therefore, this study rejects the first hypothesis (H1) and concludes that there is an insignificant association between the delta of risk disclosure and the delta of firm size in listed banks.

Agency theory asserts that large companies that have high assets will disclose more in order to minimise asymmetrical information between managers and users, but in this study the results were contrary.

The multiple regression result was not able to prove the influence of size on risk disclosure. This means that the delta of the assets of listed banks did not support banks in reporting their risk in more detail. The result contradicts agency theory; however, it is in accordance with Popova et al. (2013); Agyei-Mensah (2012); Mathuva (2012) and Rajab and Handley-Schachler (2009) who all found that firm size did not have any association with disclosure.

Therefore, this study rejects the first hypothesis (H1) and concludes that there is an insignificant association between the delta of risk disclosure and the delta of firm size in listed banks

The association between the delta of risk disclosure and the delta of liquidity in listed banks

Table 6.16 shows that the p value was 0.382 and higher than alpha 0.05, meaning that the association between the delta of risk disclosure and the delta of liquidity was insignificant. In addition, based on table 6.17, LDR did not have a positive correlation

with the delta of risk disclosure. Those results indicate that delta of liquidity in listed banks did not affect banks to report their risk more transparently. Therefore, a positive association between the delta of risk disclosure and the delta of liquidity as the second hypothesis (H2) is rejected.

Signalling theory suggests that a firm with a high liquidity ratio provides more disclosure in its annual report. This study's results contradict signalling theory, but they are in accordance with Elzahar and Hussainey (2012). Agyei-Mensah (2012) and Mathuva (2012) tested the relationship between liquidity and disclosure, and they found an insignificant association between those variables. Therefore, the association between the delta of risk disclosure and the delta of liquidity posited in the second hypothesis (H2) is rejected.

Table 6.16 The Pearson's Correlation of listed banks

	ASSETS	LDR	ROE	LEVERAGE	EARNINGS REIV	RISKDISC
ASSETS	1.000					
LDR	0.092 (0.327)	1.000				
ROE	-0.013 (0.893)	-0.040 (0.668)	1.000			
LEVERAGE	-0.074 (0.429)	-0.075 (0.421)	0.111 (0.234)	1.000		
EARNINGSREINV	0.150 (0.109)	-0.169 (0.070)	-0.018 (0.851)	0.000 (0.993)	1.000	
RISKDISC	0.086 (0.357)	0.082 (0.382)	0.041 (0.660)	-0.100 (0.285)	-0.074 (0.430)	1.000

P-values are given in parentheses. The number of observations is 116. **. Correlation is significant at the 0.01 level (1-tailed). *. Correlation is significant at the 0.05 level (1-tailed).

The association between the delta of risk disclosure and the delta of profitability in listed banks

The relationship between the delta of risk disclosure and the delta of profitability in table 6.16 shows an insignificant association. The result of multiple regressions also indicated that the delta of profitability did not affect the delta of risk disclosure. Therefore, the third hypothesis (H3) that supposed a positive association between the delta of risk disclosure and the delta of profitability is rejected.

Table 6.17 Summary of Regression Risk Disclosure in Listed Banks

Variables	β	T	Sig t	Hypothesis
ASSETS	0.086	0.898	0.371	H1:Rejected
LDR	0.056	0.582	0.562	H2:Rejected
ROE	0.054	0.570	0.570	H3:Rejected
Leverage	-0.096	-1.007	0.316	H4:Rejected
Earnings Reinvestment	-0.076	-0.791	0.431	H5:Rejected
Adjusted R square =- 0.015 F = 0.668 F table (5;116)= 2.29 Fsig. = 0.648 DW = 2.565				H6:Rejected

Source: adopted from SPSS results

Profitability demonstrates a bank's ability to generate profit, and a profitability ratio is needed by investors to measure their profit related to their investment in the bank. Signalling theory asserts that highly profitable firms deliver signals to show their good performance more transparently. However, the relationship between the delta of risk disclosure and profitability in table 6.17 shows that profitability and risk disclosure had an insignificant association. This indicates that listed banks did not report their risk transparently as a result of the delta of profitability.

This result is in line with Elzahar and Hussainey (2012) who found that profitability and risk disclosure had an insignificant association. Therefore, the third hypothesis (H3) that

supposed a positive association between the delta of risk disclosure and the delta of profitability is rejected.

The association between the delta of risk disclosure and the delta of leverage in the listed banks

The result of the relationship between the delta of risk disclosure and the delta of leverage is shown in table 6.16. The p significance was 0.316 (table 6.17), which is higher than the level of confidence (0.05). This means that the association between the delta of risk disclosure and the delta of leverage in listed banks was insignificant. The result of regression also indicated that the delta of leverage had an insignificant association with the delta of risk disclosure. Therefore, the fourth hypothesis (H4) that supposes a positive association between the delta of risk disclosure and the delta of leverage is rejected.

This result does not fit with agency theory, which suggests that a company with high leverage will tend to provide firm information in more detail. Firms explain their performance in more detail in order to minimise asymmetrical information between managers and depositors with regard to how well they manage their money and cover risks in order to reassure that they can be relied upon to manage funds. Nevertheless, in this study listed banks did not reveal their risk performance in more detail to explain the delta of leverage. This may have been because banks were unwilling to explain leverage in more detail, because leverage could send a negative image for stakeholders related to bankruptcy.

The result is in accordance with Andres, Azrofa, and Lopez (2005); Oliveira, Rodrigue, Craig (2006); Rajab and Schachler (2009) who attested that risk disclosure and leverage

did not have an association. Therefore, the fourth hypothesis (H4) that supposes a positive association between the delta of risk disclosure and the delta of leverage is rejected.

The association between the delta of risk disclosure and the delta of earnings reinvestment in listed banks

Table 6.16 shows the result of the association between the delta of risk disclosure and the delta of earnings reinvestment. The p significance is 0.431, which is higher than 0.05. This result shows that the delta of risk disclosure in listed banks did not have a relationship with the delta of earnings reinvestment. This result is supported by the regression correlation result in table 6.17, which indicates that the delta of earnings reinvestment had an insignificant influence on the delta of risk disclosure. Therefore, the fifth hypothesis (H5) that supposes an association between the delta of risk disclosure and the delta of earnings reinvestment is rejected.

This result reflects that the delta of risk disclosure in listed banks did not have a relationship with the delta of earnings reinvestment. This means banks did not report earnings reinvestment in more detail in order to attract the investors. It might have been because the investors preferred to consider dividends more than earnings reinvestment; hence, the listed banks did not transparently explain earnings reinvestment. Moreover, as the dividend theory is still in debate, so that on one side companies perceive that giving high dividends is good for shareholders and the company, on the other side they perceive that paying low dividends is good as well. The dividends irrelevance theory (MM, 1961) suggests that whether the investors get higher or lower dividends from the

normal rate gives a signal that the company might have to deal with a default in the future. Meanwhile the Clientele Effect asserts that one group of investors prefers to receive dividends now, the other group prefers not to. This indicates that investors have different points of view that induce banks not to explain risks related to the earnings reinvestment plan in more detail. Therefore, hypothesis five (H5) that supposes a positive association between the delta of risk disclosure and the delta of earnings reinvestment is rejected.

The association between the delta of risk disclosure and the delta of firm characteristics in listed banks

Table 6.17 shows that the adjusted R square was very small (-0.015), which means the delta of firm size, liquidity, profitability, leverage and earnings reinvestment did not explain the delta of risk disclosure in listed banks, and that therefore Model 1 in this study was not fit for explaining the factors influenced listed banks in reporting their risk in more detail in the annual report. The F in table 6.17 also shows insignificant correlation between the delta of firm characteristics and the delta of risk disclosure. Along with that, the sixth hypothesis (H6) that supposes there is an association between the delta of risk disclosure and the delta of firm characteristics is rejected.

Table 6.17 shows that the F is very small and insignificant, it means that the delta of risk disclosure in listed banks was not affected by firm characteristics, namely bank size, liquidity, profitability, leverage, and earnings reinvestment. The adjusted R square of this model was -0.015, which means the delta of firm size, liquidity, profitability, leverage and earnings reinvestment could not explain the delta of risk disclosure in listed banks. The F of this model also showed that in reporting their risks, listed banks were not influenced

by firm characteristics. The results show that model 1 of this study was not fit for predicting the association between firm characteristic and risk disclosure in listed banks. Therefore, the sixth hypothesis (H6) that supposes there is an association between the delta of risk disclosure and the delta of firm characteristics is rejected.

6.6.3 RQ 3.3: The factors affecting banks' decisions to disclose risks - unlisted banks

This section explains the result of Model 1 and answers the third research question for unlisted banks. The correlation and regression result for unlisted banks are summarised in tables 6.18 and 6.19.

The association between the delta of risk disclosure and the delta of firm size in unlisted banks

The association between the delta of risk disclosure and the delta of assets of unlisted banks is shown in table 6.18, with p significance of 0.193. This means that the delta of assets had an insignificant relationship with the delta of risk disclosure. The regression in table 6.19 shows that the delta of assets did not affect the delta of risk disclosure. Therefore, this study rejects the first hypothesis (H1) and concludes that the delta of risk disclosure and the delta of firm size in unlisted banks did not have a positive significant association.

The association between the delta of risk disclosure and the delta of assets is shown in tables 6.18 and 6.19. The result shows that the delta of assets had an insignificant relationship with the delta of risk disclosure. This condition signifies that unlisted banks

reporting their risks did not consider merely the delta of assets, but the reporting may have been based on other variables or considerations regarding the benefit or disadvantage of disclosure.

This result is in accordance with Popova et al. (2013), and Mathuva (2012) who asserted that firm size had an insignificant association with risk disclosure. Therefore, this study rejects the first hypothesis (H1) and concludes that the delta of risk disclosure and the delta of firm size in unlisted banks did not have a significant association.

The association between the delta of risk disclosure and the delta of liquidity in unlisted banks

Table 6.18 shows that the relationship between the delta of risk disclosure and the delta of liquidity was 0.038; this indicates that the association between risk disclosure and liquidity in unlisted banks was significant. However, this result was not supported by the result of regression as shown in table 6.19, whereby the delta of liquidity did not influence unlisted banks to report risk more transparently in their annual reports. Therefore, the second hypothesis (H2) that supposes a positive association between the delta of risk disclosure and the delta of liquidity is rejected.

Signalling theory asserts that a firm which has a high liquidity ratio provides more disclosure in its annual report than a firm with low liquidity. Meanwhile, tables 6.18 and 6.19 indicate that the delta of risk disclosure was not affected by the delta of liquidity in unlisted banks. It can be stated that neither high nor low liquidity affected the degree of risk disclosure reported by unlisted banks; however, it may have been affected by other factors. This result is consistent with Elzahar and Hussainey (2012) and Agyei-Mensah

(2012) who found that liquidity had an insignificant association with disclosure. Therefore, the second hypothesis (H2) that supposes a positive association between the delta of risk disclosure and the delta of liquidity is rejected.

The association between the delta of risk disclosure and the delta of profitability in unlisted banks

The relationship between the delta of risk disclosure and the delta of profitability can be seen in table 6.18. The p value shows an insignificant relationship between the delta of profitability and the delta of risk disclosure; meanwhile, multiple regressions show that the delta of profitability had a negative effect on the delta of risk disclosure. As a result, the third hypothesis (H3) that supposed a positive association between the delta of risk disclosure and the delta of profitability is rejected

Table 6.18 The Pearson Correlation of unlisted banks

	ASSET	LDR	ROE	LEVERAGE	EARNINGSRE	RISKDISC
ASSET	1					
LDR	0.277** (0.000)	1				
ROE	-0.014 (0.424)	0.149* (0.019)	1			
LEVERAGE	0.211** (0.002)	0.403** (0.000)	0.228** (0.001)	1		
EARNINGSRE	0.156* (0.015)	0.216** (0.001)	0.250** (0.000)	0.236** (0.000)	1	
RISKDISC	0.062 (0.193)	0.127* (0.038)	-0.094 (0.094)	0.210** (0.002)	0.049 (0.249)	1

P-values are given in parentheses. The number of observations is 196. **. Correlation is significant at the 0.01 level (1-tailed). *. Correlation is significant at the 0.05 level (1-tailed).

Table 6.19 Summary of the Result of Regression Risk Disclosure in unlisted banks

Variables	s	t	Sig t	Hypothesis
Assets	-0.006	-0.085	0.932	H1:Rejected
LDR	0.060	0.755	0.451	H2:Rejected
ROE	-0.159	-2.155	0.032	H3:Rejected
Leverage	0.217	2.750	0.007	H4:Accepted
Earnings Reinvestment	0.025	0.341	0.733	H5:Rejected
Adjusted R square = 0.044 F = 2.816 F table (5;195) = 2.26 Fsig = 0.018 DW = 2.324				H6:Accepted

Source: adopted from SPSS results

This result contradicts with Watson et al. (2002) who mentioned that in signalling theory, highly profitable corporations send positive signals by disclosing more of their performance in order to ensure their stakeholders are satisfied with the firm's effort in gaining profit. In addition, Inchausti (1997) explained that firms with high earnings will disclose more in their annual report than companies with low earnings.

The result is in line with earlier researchers, i.e. Aljifri et al. (2014); Elzahar and Hussainey (2012) who found that profitability and disclosure did not have a significant correlation. Therefore, the third hypothesis (H3) that supposed a positive association between the delta of risk disclosure and the delta of profitability is rejected.

The association between the delta of risk disclosure and the delta of leverage in unlisted banks

The statistical result of the relationship between the delta of risk disclosure and the delta of leverage is shown in table 6.18. The p value shows that the delta of leverage individually had a significant positive association with the delta of risk disclosure. Therefore, the fourth hypothesis (H4) that supposes a positive association between the delta of risk disclosure and the delta of leverage is accepted. This result indicates that

unlisted banks revealed their performance in more detail because of their leverage level. Because the main sources of funds in unlisted banks are from debts, commonly such banks are highly leveraged; therefore, unlisted banks are more willing to reveal their risks. Moreover, unlisted banks are willing to disclose risks because they want to show their capability in managing debts in order to promote a positive image to stakeholders.

Agency theory assumes that firms with high leverage will disclose more to explain their performance in order to meet their creditors' interests. The result is in line with agency theory and Naser et al. (2002), who asserted that highly leveraged firms will disclose more in their reports to indicate good signals in order to resolve their debts. Therefore, the fourth hypothesis (H4) that supposes a positive association between the delta of risk disclosure and the delta of leverage is accepted.

The association between the delta of risk disclosure and the delta of earnings reinvestment in unlisted banks

Table 6.18 shows the result of the association between the delta of risk disclosure and the delta of earnings reinvestment. The p significance is 0.249, and reflects that the delta of risk disclosure in unlisted banks did not have a relationship with the delta of earnings reinvestment. The regression result (table 6.19) also exhibits that the delta of earnings reinvestment did not affect the delta of risk disclosure. Therefore, the fifth hypothesis (H5) that supposes a positive association between the delta of risk disclosure and the delta of earnings reinvestment is rejected.

Agency theory posits that by paying dividends, agency conflict can be reduced. According to Baker and Powell (2012), to compensate for a high risk investment, firms

which have low disclosure are expected to pay higher dividends. However, while it is expected that firms with low level disclosure will pay more in dividends than companies with a high level of disclosure. They Baker and Powell actually found a positive relationship between the quality of disclosure and dividend per share. Thereby, a company which has a reinvestment policy should disclose more in order to make sure that investors, by reinvesting their earnings, will receive higher earnings in the future.

It can be concluded that unlisted banks did not explain their risk more transparently based on an earnings reinvestment plan. Therefore, the fifth hypothesis (H5) that supposes a positive association between the delta of risk disclosure and the delta of earnings reinvestment is rejected.

The association between the delta of risk disclosure and the delta of firm characteristics in unlisted banks

Table 6.19 shows that the adjusted R square and F are 0.044 and 2.816 respectively. The delta of firm characteristics could not explain the delta of risk disclosure due to the adjusted R square being very small. The F indicates that the association between the delta of risk disclosure and the delta of company characteristics in unlisted banks was significant. This study accepts the sixth hypothesis (H 6) and concludes that there is an association between the delta of risk disclosure and the delta of firm characteristics in unlisted banks.

The unlisted banks provided risk reports but the extent of their disclosure was not merely based on firm characteristics, and might be explained by other variables. Because F is higher than F table it means that the delta of aggregate firm characteristics had a

significant effect on the delta of risk disclosure. Therefore, this study accepts the sixth hypothesis (H6) and concludes that there was a significant association between the delta of risk disclosure and the delta of company characteristics in unlisted banks. Moreover, the regression of model 1 in this study was not fit for testing the factors affecting unlisted banks in disclosing more risk in their reporting.

To sum up, individually Pearson's correlation shows that out of the following: the delta of firm size, liquidity, profitability, and earnings reinvestment, not one had a significant relationship with the delta of risk disclosure in unlisted banks. The F statistics in Model 1 was significant. All this evidence indicates that the sixth hypothesis (H6), which supposes there is a relationship between the delta of risk disclosure and the delta of firm characteristics should be accepted.

6.6.4 RQ 3.4 The factors affecting a bank's decision to disclose risk in Islamic banks

This part answers the factors that affect a bank's decision to report risk in Islamic and non-Islamic banks. Because the total number of data sets for the Islamic banks group was only 27 and in order to demonstrate the influence of firm characteristics on risk disclosure by regression, the data had to be tested for normality, heterocedasticity, multicollinearity, and autocollinearity. After testing the normality by a Kolmogorov and Smirnov test, the variables of the delta of earnings reinvestment and the delta of firm value did not show up as normal; hence, those variables had to be transformed into Logarithm (Log), Natural Logarithm (Ln), or inverse, etc. Nevertheless, by transforming into inverse, Log. and Ln., the earnings reinvestment variables still did not show a normal

shape, the rest of N was only 5 (Appendix F). Moreover, most of the delta of earnings reinvestment data was zero, possibly because Islamic banks did not distribute dividends between the years 2008-2012. Finally, for the best solution and in order to process correlation and regression tests, the delta of earnings reinvestment variable was excluded from the Islamic banks model. Based on those reasons, the firm characteristic variables which were tested in Islamic banks were size, liquidity, profitability, and leverage. Along with that, the fifth hypothesis was also excluded. Each correlation is explained as below:

The association between the delta of risk disclosure and the delta of firm size in Islamic banks

The association between the delta of risk disclosure and the delta of assets is shown in table 6.20 whereby p value is $0.077 > \alpha 5\%$, meaning that individually the delta of company size did not have a relationship with the delta of risk disclosure. The statistical regression in table 6.21 shows that the delta of assets had an insignificant effect on the delta of risk disclosure. Based on agency theory, it is expected that companies with large assets have more complicated business and have more stakeholders than small companies, hence they disclose more in order to minimise asymmetrical information between managers and users. Nevertheless, this study's findings contradict agency theory, and instead support previous scholars, namely Ibrahim (2011); Rajab and Handley-Schachler (2009) who demonstrate that firm size does not have relationship with risk disclosure. It means the delta of firm size was not a strong variable in determining risk disclosure. The statistical regression, as shown in table 6.21, is insignificant so it is not able to support the first hypothesis. This could be explained by

the fact that Islamic banks did not consider assets as the factor that influenced them to report risk more transparently. Therefore, this study rejects the first hypothesis (H1) and concludes that there was no association between the delta of risk disclosure and the delta of firm size.

The association between the delta of risk disclosure and the delta of liquidity in Islamic banks

Table 6.20 shows that the p value was 0.055, higher than alpha 0.05, meaning that the association between the delta of risk disclosure and the delta of liquidity was insignificant. Table 6.21 demonstrates that the delta of liquidity did not affect Islamic banks in disclosing more risk in their reporting. The result indicates that Islamic banks did not reveal their risk more transparently based on the delta of finance to deposit ratio (FDR). This is not in line with signalling theory, which suggests a firm which has a high liquidity ratio provides more disclosure.

This study does support the findings of previous researchers, i.e. Agyei-Mensah (2012); Elzahar and Hussainey (2012); Mathuva (2012), who asserted that risk disclosure and liquidity had an insignificant relationship. It means that liquidity is not a strong factor in determining risk disclosure in Islamic banks. Therefore, the second hypothesis (H2) that supposes a positive association between the delta of risk disclosure and the delta of liquidity is rejected.

The association between the delta of risk disclosure and the delta of profitability in Islamic banks

The relationship between the delta of risk disclosure and the delta of profitability is demonstrated in table 6.20. The p value signifies that the delta of profitability did not have a relationship with the delta of risk disclosure. Table 6.21 shows that the delta of profitability had an insignificant effect on the delta of risk disclosure. This indicates that Islamic banks did not explain their risk performance in more detail because the delta of profitability neither increased nor decreased. This result implies that profitability did not significantly determine risk disclosure in Islamic banks. In other words, Islamic banks did not consider the delta of profitability in reporting their risk more transparently in their annual reports.

The research that was done by Elzahar and Hussainey (2012) supports this research because they also found that profitability had an insignificant association with risk disclosure. Due to that, the third hypothesis (H3) that supposes a positive association between the delta of risk disclosure and the delta of profitability is rejected.

Table 6.20 The Pearson's correlation of firm characteristics, risk disclosure and firm value in Islamic banks

	ASSETS	LDR	ROE	LEVERAGE	RISKDISC	FIRMVALUE
ASSET	1					
LDR	0.051 (0.400)	1				
ROE	-0.145 (0.235)	0.228 (0.126)	1			
LEVERAGE	-0.323 (0.050)	-0.126 (0.265)	0.122 (0.272)	1		
RISKDISC	-0.282 (0.077)	-0.314 (0.055)	-0.180 (0.185)	0.113 (0.287)	1	
FIRMVALUE	0.210 (0.147)	0.117 (0.280)	-0.049 (0.405)	-0.050 (0.402)	-0.094 (0.321)	1

P-values are given in parentheses. The number of observations is 27. **. Correlation is significant at the 0.01 level (1-tailed). *. Correlation is significant at the 0.05 level (1-tailed).

Table 6.21 Summary of the Result of OLS Regression Risk Disclosure in Islamic banks

Variables	s	t	t sig	Hypothesis
Assets	-0.290	-1.426	0.168	H1:Rejected
LDR	-0.261	-1.309	0.204	H2:Rejected
ROE	-0.163	-0.814	0.424	H3:Rejected
Leverage	0.006	0.031	0.976	H4:Rejected
Adjusted R square = 0.047 F= 1.323 F table (4;22) = 2.816 Fsig = 0.293 DW = 1.756				H6: Rejected

Source: adopted from SPSS

The association between the delta of risk disclosure and the delta of leverage in Islamic banks

The result of the relationship between the delta of risk disclosure and the delta of leverage is shown in table 6.20. The p value was 0.287 and higher than 5%, which indicates that the association between the delta of risk disclosure and the delta of leverage was insignificant. The evidence of an insignificant effect between the delta of risk disclosure and the delta of leverage is shown in table 6.21. Therefore, the fourth hypothesis (H4) that supposes a positive association between the delta of risk disclosure and the delta of leverage is rejected.

The association between the delta of risk disclosure and the delta of firm characteristics in Islamic banks

Table 6.21 demonstrates $F (1.323) < F \text{ table}$, meaning that aggregate firm characteristics insignificantly affected the delta of risk disclosure. This result is supported by the adjusted R square for model 1 being 0.047, which means only about 4.7% of the delta of risk disclosure was explained by firm size, liquidity, profitability, leverage and the remaining 95.3 % might be explained by other factors which were not tested in this study. It is

concluded that Model 1 was not fit for predicting the correlation between the delta of firm characteristics and the delta of risk disclosure in Islamic banks. Based on those results, this study rejects the sixth hypothesis (H6) that supposes there is an association between the delta of risk disclosure and the delta of firm characteristics.

Adjusted R square for model 1 is 0.047, which means only about 4.7% of risk disclosure was explained by firm size, liquidity, profitability, leverage and the remaining 95.3 % might be explained by other factors which were not tested in this study. The result suggests that in reporting risk, Islamic banks were not affected by the delta of firm size, liquidity, profitability, and leverage. This finding supports the theory that Islamic banks considered other factors when they decided to report their risk in more detail. Based on those results, this study rejects the sixth hypothesis (H6) that supposes there is an association between the delta of risk disclosure and the delta of firm characteristics. Furthermore, it is concluded that model 1 was not fit for predicting the relationship between the delta of firm characteristics and the delta of risk disclosure in Islamic banks.

To sum up, for model 1, none of the firm characteristics, namely firm size, liquidity, profitability, and leverage, had an insignificant association with risk disclosure; even the adjusted R squared was only 0.047 and F was insignificant. These statistical results demonstrate that Model 1 was not fit for explaining factors affecting Islamic banks in reporting risk.

6.6.5 RQ 3.5 The factors affecting banks' decision to disclose risk in non-Islamic banks

Each hypothesis for Model 1 will be explained as follows:

The association between the delta of risk disclosure and the delta of firm size in non-Islamic banks

The individual association between the delta of risk disclosure and the delta of firm size is shown in table 6.22. The probability result of 0.177 means that the delta of assets had an insignificant relationship with risk disclosure. This is also supported by the p value, which was higher than 0.05, as shown in table 6.23.

It demonstrates that non-Islamic banks did not disclose more of their performance based on the delta of assets but possibly based on other factors. The result contradicts agency theory, which suggests that large companies with high assets disclose more in order to minimise asymmetrical information between managers and users. However, this study is in line with previous researchers such as Rajab and Handley-Schachler (2009) and Aljifri and Hussainey (2007), who demonstrated that firm size did not have a significant association with disclosure. As a result, this study rejects the first hypothesis (H1), and concludes that there is an insignificant association between the delta of risk disclosure and the delta of firm size.

The association between the delta of risk disclosure and the delta of liquidity in non-Islamic banks

Table 6.22 shows that there was a positive relationship between the delta of risk disclosure and the delta of liquidity. Moreover, the delta of liquidity affected banks in reporting their risk, which was indicated by p value 0.038 in table 6.23. This may have been because banks borrow their source of funds for loans and wanted to show the stakeholders how the banks effectively manage their liquidity ratio. Non-Islamic banks

need to stress their capability to provide funds when customers withdrawn their money anytime. Thereby, non-Islamic banks explained risk in more detail with regard to the delta of liquidity.

Watson et al. (2002) asserted that signalling theory posits that firms with high liquidity will disclose more and deliver better signals than firms with lower liquidity. This result is consistent with signalling theory and it is supported by Marshall and Weetman (2007) and Espinosa et al. (2005) who revealed that liquidity had a significant association with risk disclosure. Therefore, the second hypothesis (H2) that supposes a positive association between the delta of risk disclosure and the delta of liquidity is accepted.

The association between the delta of risk disclosure and the delta of profitability in non-Islamic banks

The relationship between the delta of risk disclosure and profitability can be seen in table 6.22. The p significance is higher than alpha 5%, this means that the relationship between the delta of risk disclosure and the delta of profitability was insignificant. This is supported by the result in table 6.23. This demonstrates that non-Islamic banks did not consider whether the delta of profitability had increased or declined when explaining their firm performance more transparently. This result contradicts signalling theory, which supposes that highly profitable firms disclose their performance more fully; nevertheless, it is in line with Inchausti (1997) who mentioned that agency theory suggests companies with low profit will disclose more to contextualise their worse performance. Moreover, this study supports the findings of Elzahar and Hussainey (2012), who mentioned that profitability had an insignificant association with risk disclosure. As a result, the third

hypothesis (H3) that supposes a positive association between the delta of risk disclosure and the delta of profitability is rejected.

The association between the delta of risk disclosure and the delta of leverage in non-Islamic banks

The result of the relationship between the delta of risk disclosure and the delta of leverage is shown in table 6.22, with p value higher than 5%. The result means that the association between the delta of risk disclosure and the delta of leverage is not significant. The insignificant effect of leverage to risk disclosure is also shown in table 6.23. Non-Islamic banks did not consider the delta of leverage when they reported their risk performance more transparently in annual reports. This result is not in accordance with agency theory, which asserts that highly leveraged companies tend to provide information more transparently to fulfil their creditors' interest. However, research done by Elzahar and Hussainey (2012); Rajab and Handley-Schachler (2009) support this study, because they agreed that leverage did not have a relationship with risk disclosure. Therefore, the fourth hypothesis (H4) that supposes a positive association between the delta of risk disclosure and the delta of leverage is rejected.

The association between the delta of risk disclosure and the delta of earnings reinvestment in non-Islamic banks

Table 6.23 reveals the result of the association between the delta of risk disclosure and the delta of earnings reinvestment, which has p significant more than 5%. This result indicates that risk disclosure had an insignificant correlation with earning reinvestment. It reflects that risk disclosure had an insignificant correlation with earnings reinvestment.

The regression result was not able to support the association above, in other words earnings reinvestment that had been done by non-Islamic banks did not affect the transparency with which banks revealed their risk.

The result is not in line with Bamber and McMeeking (2012) who asserted that in signalling theory, firms with low disclosure are supposed to pay higher dividends. It connotes that firm with low earnings reinvestment will more transparent in explain their performance. Moreover, non-Islamic banks explained risk in more detail did so not merely because of the delta of earnings reinvestment, but possibly affected by other factors. Therefore, the fifth hypothesis (H5) that supposes a positive association between the delta of risk disclosure and the delta of earnings reinvestment is rejected.

Table 6.22 The Pearson's correlation between the delta of firm characteristics, the delta of risk disclosure and the delta of firm value in non-Islamic banks

	ASSETS	LDR	ROE	LEVERAGE	EARNINGREIV	RISKDISC	FIRMVALUE
ASSETS	1						
LDR	0.054 (0.181)	1					
ROE	-0.005 (0.465)	0.019 (0.374)	1				
LEVERAGE	-0.144** (0.007)	0.295** (0.000)	0.115* (0.027)	1			
EARNINGREIV	0.071 (0.118)	0.179** (0.001)	0.044 (0.230)	0.157** (0.004)	1		
RISKDISC	0.055 (0.177)	0.148** (0.006)	0.000 (0.498)	0.083 (0.082)	0.031 (0.303)	1	
FIRMVALUE	-0.010 (0.431)	-0.017 (0.387)	0.860** (0.000)	0.108* (0.034)	-0.002 (0.484)	0.023 (0.352)	1

P-values are given in parentheses. The number of observations is 285. **. Correlation is significant at the 0.01 level (1-tailed). *. Correlation is significant at the 0.05 level (1-tailed).

Table 6.23 Summary of the Result of OLS Regression Risk Disclosure in non-Islamic banks

Variables	S	T	t Sig	Hypothesis
Assets	0.056	0.931	0.353	H1:Rejected
LDR	0.130	2.081	0.038	H2:Accepted
ROE	-0.008	-0.132	0.895	H3:Rejected
Leverage	0.054	0.851	0.396	H4:Rejected
Earnings Reinvestment	-0.005	-0.079	0.937	H5:Rejected
Adjusted R square = 0.009 F test = 1.535 F table (5;284) = 2,25 Fsig. = 0.179 DW = 2.404				H6:Rejected

Source: adopted from SPSS result

The association between the delta of risk disclosure and the delta of firm characteristics in non-Islamic banks

Table 6.23 shows that $F (1.535) < F \text{ table } (2.25)$, meaning that the aggregate delta of firm characteristics did not significantly affect the delta of risk disclosure. The adjusted R square for Model 1 was 0.009, which means only about 0.9% of the delta of risk disclosure is explained by the delta of firm size, liquidity, profitability, leverage and earnings reinvestment, with the rest possibly being explained by other factors. This is proved by the adjusted R square for model 1, which is 0.009, that means only about 0.9%, the delta of risk disclosure is explained by the delta of firm size, liquidity, profitability, leverage and earnings reinvestment, and the rest might be explained by other factors. Hence, the sixth hypothesis (H6) that supposes the delta of firm characteristics has an association with the delta of risk disclosure is rejected. This means that the delta of firm characteristics did not influence non-Islamic banks to report their risk in more detail.

To sum up, for model 1, only the delta of liquidity had a significant positive relationship with the delta of risk disclosure, while the delta of the following: firm size, profitability, leverage, and earnings reinvestment did not have relationship with the delta of risk disclosure. In addition, this study demonstrates that the delta of firm characteristics was not able to explain the delta of risk disclosure because adjusted R square was very small. The delta of firm characteristics did not affect risk disclosure, because F test is insignificant. Therefore, Model 1 was not fit for predicting the association between the delta of firm characteristics and the delta of risk disclosure. Hence, the sixth hypothesis (H6) that supposes the delta of firm characteristics have an association with the delta of risk disclosure is rejected.

All in all, for Model 1, this study found that the delta of firm characteristics was not able to explain the delta of risk disclosure because the adjusted R square was very small. Moreover, the delta of firm characteristics aggregate did not affect the delta of risk disclosure because F test was insignificant.

6.7 The Results of RQ4 - The Value Relevance of Risk Disclosure

This part describes the empirical results in answering research question number four, which examines the value relevance of risk disclosure. This sub chapter is divided into five parts, related to the bank sectors.

Harold Lasswell (1948) suggested that a model of communication should answer a simple question namely: who, says what, in which channel, to whom, and what is the effect. It means that risk disclosure is value relevant for users when it can signify that a manager (who) has already reported the firm's performance (as says what) in the form

of its annual report (as which channel). Annual reports are issued for the needs of stakeholders (as to whom) which are used as material for consideration in making decisions (as what that effect). Regarding communication theory, a manager as a representative of a company, sends messages and gives signals through a firm's annual reports.

The stakeholders as receivers will read the information in the annual report and consider it when making decisions. Nevertheless, information in the annual report could contain noises that make the expected signals more difficult to interpret accurately and this could cause misperception, and result in reporting that is not in accordance with receivers' expectation, and finally could affect investors in making their decisions.

Agency theory asserts that companies which provide more transparent information are able to minimise information asymmetry between managers and users. The annual report is fruitful and value relevant for investors if firms reveal their information in more detail and accurately in terms of what the stakeholder needs and is interested in.

6.7.1 RQ 4.1: The value relevance of risk disclosure in all banks

The results of Model 2 are summarised in tables 6.24 to 6.25

The association between the delta of firm value and the delta of firm size in all banks

The evidence in table 6.24 that p value is 0.432 indicates that individually the delta of bank size did not have a relationship with the delta of firm value. Besides, p value of

regression in table 6.25 also points to an insignificant impact of the delta of assets on the delta of firm value.

Meanwhile, agency theory asserts that large companies have a strong financial incentive to pay consultants to produce transparent reports about their performance in order to minimise agency conflicts between managers and shareholders, and hence increase firm value (Sheu et al., 2010). Moreover, Al-Akra and Ali (2012), Uyar and Kiliç (2012) assert that large firms have high total assets, which means managers are able to use assets more flexibly and productively for financing the firm's operations in order to generate high profits, gain a good image with stakeholders, and maintain their reputation and finally increase firm value.

This result contradicts agency theory and most prior research; however it is in line with Chen and Chen (2011) who argued that when a firm which has the same profitability, firm size does not affect firm value. In addition, this might happen because stakeholders valued the firm not based on assets, but possibly based on other variables that were not tested in this study.

To sum up, the seventh hypothesis (H7) which asserted there was a positive association between the delta of firm size and the delta of firm value is rejected.

The association between the delta of firm value and the delta of liquidity in all banks

The relationship between the delta of firm value and the delta of liquidity had a p value 0.389 with a negative sign. This means the delta of firm value had a negative insignificant

association with the delta of liquidity. Moreover, the delta of liquidity did not influence the banks to report their risks more transparently, because p value in table 6.25 shows a negative sign and an insignificant correlation.

Even though liquidity is an important ratio for measuring a firm's ability to repay its short term debts, it does not support an increase in firm value. It might be that liquidity does not have a direct correlation with generating profit; therefore, it is not able to support an increase in share price. Moreover, other factors might influence firm value. This result is in line with Al-Akra and Ali (2012) who asserted that liquidity does not have an association with firm value. Hence, the eighth hypothesis (H8) is rejected.

The association between the delta of firm value and the delta of profitability in all banks

A strong positive significant association between the delta of profitability and the delta of firm value is shown by p value 0 in table 6.24. This association is also supported by the result of regression in table 6.25 that shows p value was 0. This result indicates that the delta of profitability has a positive significant association with the delta of firm value.

Profitability explains how well the banks manage their funds and risks in order to achieve profit. Stakeholders perceive that highly profitable banks are more beneficial. Along with that, investors and potential investors tend to be satisfied with what banks have done and this might make them more interested in buying their shares, and it will push share price up and then finally increase firm value. Rising profit from year to year shows the enhancement of banks' net income that indicates a rise in the value of the firm. It also gives a positive image for stakeholders and supports firm value increase. The association

between profitability and firm value is clearly supported by Uyar and Kiliç (2012) who asserted a significantly positive correlation between firm value and profitability. All in all, it was found that highly profitable banks increased their firm value; hence, the ninth hypothesis (H9) is accepted.

The association between the delta of firm value and the delta of leverage in all banks

The positive relationship between the delta of firm value and the delta of leverage in this study is shown by p value 0.035 (table 6.24). Nevertheless, the delta of firm value was not affected by the delta of leverage as shown in table 6.25 which shows p value was 0.460, and higher than 0.05. Therefore, this research indicates that the delta of leverage had an insignificant effect on the delta of firm value.

The banks' main sources of funds are debts from third parties. Banks tend to have high debts, which reflect their capability to collect their funds and how they manage the funds efficiently and effectively for making a profit. Khan, Kaleem, and Nazir (2012) argued that based on agency and signalling theories, in companies with a small proportion of managerial ownership, debts can be used to minimise free cash flow and the agency costs of controlling managers, hence the relationship between leverage and firm value should be positive. By contrast, the amount of leverage can be considered as a predictor of company risk or bankruptcy. This means that the greater the leverage, the higher the debt, indicating a greater investment risk that might mean the company cannot pay its debts. Highly leveraged companies convey a negative sign that supports a negative reaction for users, which then ultimately affects the value of the company. Accordingly,

firms with low leverage increase firm value and the risks are smaller than for highly leveraged companies. This is supported by Babaei et al. (2013) who found that leverage had a negative correlation with firm value.

This study is not in line with agency theory, which posits that leverage has a positive relationship with firm value. Moreover, the result is not in line with the second model, which supposed that the association between the delta of leverage and the delta of firm value has a negative sign. However, this research is supported by previous researchers' results, including Hassan et al. (2009); Uyar and Kiliç (2012); Brooks and Yan (1999), who mentioned that there is no relationship between leverage and firm value. Because this research indicates that leverage has an insignificant effect on firm value, the tenth hypothesis (H10) is rejected.

The association between the delta of firm value and the delta of earnings reinvestment in all banks

The result shows that p value is insignificant with a negative direction, indicating that the delta of earnings reinvestment and the delta of firm value had a negative insignificant correlation. The result of regression also indicates that the delta of earnings reinvestment did not influence the delta of firm value as shown in table 6.25.

The result is in line with Miller and Modigliani's (1961) theory, who asserted that dividend policy does not have an effect on firm value, because firm value is only affected by the ability of a firm to generate profits and manage business risks. It can be concluded that earnings reinvestment also does not increase firm value in all banks and other factors

probably will affect firm value. To sum up, the delta of earnings reinvestment policy did not boost the delta of firm value, hence the eleventh hypothesis (H11) is rejected

Table 6.24 The Pearson correlation between firm characteristics, risk disclosure and firm value

	Assets	LDR	ROE	Leverage	Earningsreinv.	Risk Disc.	Firm Value
Assets	1						
LDR	0.056 (0.160)	1					
ROE	-0.007 (0.453)	0.030 (0.297)	1				
Leverage	-0.149** (0.004)	0.260** (0.000)	0.113* (0.023)	1			
Earningsreinv	0.071 (0.106)	0.155** (0.003)	0.057 (0.157)	0.157** (0.003)	1		
Risk Disc.	0.045 (0.215)	0.120* (0.017)	-0.009 (0.440)	0.088 (0.061)	0.020 (0.361)	1	
Firm Value	-0.010 (0.432)	-0.016 (0.389)	0.842** (0.000)	0.103* (0.035)	-0.002 (0.484)	0.022 (0.352)	1

P-values are given in parentheses. The number of observations is 312. **. Correlation is significant at the 0.01 level (1-tailed). *. Correlation is significant at the 0.05 level (1-tailed).

Table 6.25. Summary of the Result of OLS Regression Firm Value in All Banks

Variables	S	T	t sig.	Hypothesis
ASSET	0.004	0.127	0.899	H7:Rejected
LDR	-0.045	-1.387	0.166	H8:Rejected
ROE	0.844	27.393	0.000	H9:Accepted
LEVERAGE	0.024	0.740	0.460	H10:Rejected
EARNINGS REINV	-0.048	-1.543	0.124	H11:Rejected
RISK DISC	0.033	1.060	0.290	H12:Rejected
Adjusted R square = 0.709 F= 127.402 F table (6;305) = 2.128 Fsig. = 0.000 DW = 1.763				H13: Accepted

Source: adopted from SPSS

Table 6.26 The Summary of Value Relevance

Sector	s	t	P sig	N	H14
All banks	-0.017	-0.414	0.679	413	R
Listed	-0.036	-0.552	0.582	145	R
Unlisted	0.047	1.320	0.188	268	R
Islamic	0.042	0.422	0.676	40	R
Non-Islamic	-0.014	-0.033	0.742	373	R

Source: adopted from SPSS R= rejected

The association between the delta of firm value and the delta of risk disclosure in all banks

The findings of this research show an insignificant relationship between the delta of risk disclosure and the delta of firm value, which is reflected by p value > 0.05, as indicated in table 6.24. The result of multiple regressions also reveals that the delta of risk disclosure did not have an association with the delta of firm value.

The main objective of a company is to maximise the wealth of shareholders or its firm value. Hence, business managers always try to demonstrate their performance and to make sure that their companies are attractive as a good alternative investment. In doing so, companies attempt to report their performance in more detail, in order to attract investors and boost firm value. Revealing their condition in more detail can reduce agency problems and asymmetric information and send good signals to investors, thereby boosting firm value.

The findings of this research indicate a positive insignificant relationship between the delta of risk disclosure and the delta of firm value, which is reflected by p sig > 0.05, as

indicated in table 6.24. The result of multivariate regression also reveals that risk disclosure did not have an impact on firm value. This means that even if banks disclosed more risk in their reports, it did not boost firm value. This result is in accordance with Wang et al (2013) who examined the influence of voluntary disclosure on firm value, and reported that an increase in disclosure in annual reports did not create value for a company. This may be because firms were reluctant to report in more detail because of the weaknesses of disclosure. By disclosing their performance, it means they show their strategies and increase cost. Returning to the twelfth hypothesis (H12) posed at the beginning of this study, the result is obviously different, and therefore the hypothesis is rejected.

The association between the delta of firm value and the delta of firm characteristics, and the delta of risk disclosure in all banks

Table 6.25 shows that $F (127.402) > F \text{ table } (12.4)$, this means that aggregated, the delta of risk disclosure and the delta of firm characteristics, namely size, liquidity, profitability, leverage, and earnings reinvestment, had a significant relationship with the delta of firm value. Based on adjusted R square, the robustness of the association between the delta of firm value and the delta of company's characteristics and the delta of risk disclosure is 0.709. This means that the delta of bank size, liquidity, profitability; leverage, earnings reinvestment, and the delta of risk disclosure explain the delta of firm value about 70.9%. When aggregate the delta of bank size, profitability ratio, leverage, and risk disclosure increased, while the delta of liquidity ratio and the delta of earnings reinvestment decreased, hence the delta of firm value increased, and the rest (29.1%) might be explained by other factors which were not tested in this research. These results show

that model 2 was appropriate to predict the association between the delta of firm value and the delta of firm characteristics and the delta of risk disclosure simultaneously.

Therefore, the thirteenth hypothesis (H13) that supposes an association between the delta of firm value and the delta of company characteristics and the delta of risk disclosure is accepted.

The value relevance of risk disclosure in all banks

The findings of this research indicate a negative insignificant relationship between risk disclosure and firm value, as indicated in table 6.26. This result shows an insignificant association between risk disclosure and firm value in all banks in Indonesia.

Regarding communication theory, a manager as a representative of the company, sends messages and gives signals through annual reports. The stakeholders as receivers will receive the information from annual reports and consider it in making decisions. Nevertheless, information in the annual report could contain noises that make the expected signals more difficult to interpret accurately and this could affect misperception, and mean that messages are not in accordance with receivers' expectation, and finally could affect investors in making their decisions. The communication process with noises can be seen in figure 3.3.

Agency theory asserts that companies which provide more transparent information are able to minimise information asymmetry between managers and users. The annual report is fruitful and value relevant for investors if firms reveal their information in more detail and accurately in ways that meet the stakeholders' needs and interests. The result

shows that overall, for banks in Indonesia, as shown in table 6.26, p value (0.679) is insignificant, indicating that risk disclosure in annual reports did not have association with firm value and was not value relevant for users. The findings of this research indicate a negative insignificant relationship between risk disclosure and firm value, which is reflected by $p > 0.05$, as indicated in table 6.26. This means that even though banks disclosed risk more fully in their reporting, this did not boost firm value. This result is in accordance with Wang et al. (2013) who examined the influence of voluntary disclosure on firm value and reported that the increase of disclosure in annual reports did not lead to the creation of value in a company. This could be because the banks are reluctant to report more detail because of the weaknesses of disclosure mentioned above. Therefore, this study rejects the fourteenth hypothesis (H14) that supposes risk disclosure is value relevant for stakeholders in all banks.

To sum up, Model 2 is fit for predicting the factors affecting bank when reporting risk, and only the delta of profitability had a significant association with the delta of firm value. The delta of firm value was explained by size, liquidity, profitability, leverage, earnings reinvestment, and risk disclosure with adjusted R square 0.709, while the remains (29.1%) were explained by other variables that were not examined in this study. The delta of firm value was influenced by the delta of risk disclosure together with the delta of assets, profitability, leverage which had a positive sign, while the delta of earnings reinvestment and the delta of liquidity had a negative sign, as explained by F higher than F table. Meanwhile, risk disclosure was not value relevant.

6.7.2 RQ 4.2 The value relevance of risk disclosure in listed banks

Table 6.27 and 6.28 show the results of the relationship between the delta of firm value and the delta of risk disclosure and the delta of firm characteristics.

The association between the delta of firm value and the delta of firm size in listed banks

Table 6.27 shows that the p value was higher than 0.05, and this indicates that the delta of firm value and the delta of assets did not have a significant correlation. Agency theory suggests that companies with large assets have a strong financial incentive to report their performance transparently, in order to minimise agency conflicts and foster a good image, hence increasing firm value. The banks with the biggest assets have the ability to pay consultants to produce reports that convince investors how strong they are and good at managing risks. The information sends positive signals to stakeholders and finally increases firm value. Nevertheless, this result contradicted with agency theory whereby the results in table 6.27 and 6.28 indicate that the delta of firm value and the delta of assets did not have a significant correlation in the listed banks. It means that assets did not affect to increase firm value in the listed banks, and assets is not the only factor which will increase value of the firm, and other factors might influence firm value which are not tested in this study. Therefore, the association between the delta of firm value and the delta of firm size in listed banks that was proposed as the seventh hypothesis (H7) is rejected.

The association between the delta of firm value and the delta of liquidity in listed banks

The individual relationship between the delta of firm value and the delta of liquidity had a p significance of 0.679 (see table 6.27). This means that the delta of firm value did not have an association with the delta of liquidity in listed banks. This study also was not able to show that the delta of liquidity influenced the delta of firm value, as presented in table 6.28.

This might be because the liquidity ratio (LDR) was not an influential variable that directly affected share price in the market, therefore it did not affect firm value. This result is in accordance with Al-Akra and Ali (2012) who stated that liquidity does not have a relationship with firm value. All in all, this study rejects the eighth hypothesis (H8) that proposes a positive association between the delta of firm value and the delta of liquidity in listed banks.

The association between the delta of firm value and the delta of profitability in listed banks

The results in table 6.27 show that the association between the delta of firm value and the delta of profitability had a p value 0 with a positive direction. This indicates that the delta of profitability had a significant positive association with firm value in listed banks. Table 6.28 also shows a significant positive effect of the delta of profitability on the delta of firm value.

A highly profitable bank can pass on high earnings to its shareholders. The efficacy of banks in distributing profit to shareholders produces a good image and impression, hence increasing the value of the firm, which is reflected in its share price. The relevance of profitability is clearly supported by the findings offered by Chen and Chen (2011) who

argued that profitability can be a factor which can affect firm value. It is also supported by Uyar and Kiliç (2012) who assert that profitability has a positive relationship with firm value because stakeholders perceive that highly profitable firms capable of managing themselves and are a prospective investment. This result in line with MM's irrelevance theory, which asserted that firm value is affected by profitability and business risk.

Hence, this study accepts the ninth hypothesis (H9) that supposes there is a positive association between the delta of firm value and the delta of profitability.

The association between the delta of firm value and the delta of leverage in listed banks

The individual relationship between the delta of firm value and the delta of leverage in this study is shown by p value 0.077 (see table 6.27) with a positive direction. This reflects that the delta of leverage in listed banks did not have a significantly positive association with the delta of firm value. The result of regression in table 6.28 shows that the delta of leverage had an insignificant influence on the delta of firm value.

According to pecking order theory, firms prefer to use internal funds, but if they are insufficient they can raise funds from debt. Even though listed banks obtain funds from external sources, they still have a high leverage. Leverage can be used for minimising agency problems by external monitoring of the managers in order to act in ways the shareholder needs. When agency problems decrease it can increase firm value. In addition, Horne (1997) asserted that a company with high leverage indicates that the company is not solvent and this influences its value. It means that if a company is highly leveraged, the firm value will decrease.

The delta of leverage did not affect the delta of firm value, as shown in tables 6.27 and 6.28. This result is not in accordance with agency theory, or Chen and Chen (2011) and Horne (1997) who suggested a negative direction in this correlation. Nevertheless, this results is in line with Uyar and Kiliç (2012) who attested that leverage did not affect firm value. It means that the delta of leverage did not affect the delta of firm value.

This result contradicts Model 2 in this study, which proposes a negative direction. Meanwhile, the findings indicate that the delta of leverage did not have a relationship with the delta of firm value. Therefore, the tenth hypothesis (H10) that supposes there is a negative association between the delta of firm value and the delta of leverage is rejected.

The association between the delta of firm value and the delta of earnings reinvestment in listed banks

Companies might not distribute their dividends if they prefer to reinvest their earnings (earnings reinvestment) in profitable investments. Bodie et al. (2011) mentioned that firms with high earnings reinvestment indicate to investors that initially they will get small earnings from dividends. However, while banks might give small dividends now, in the future banks are likely to make high earnings from reinvesting dividends in profitable investments.

Ross et al. (2008) mentioned that shareholders' purpose is to increase their wealth by receiving high dividends when they invest their funds in firms. Along with that, a company will consider the need for a dividends policy that increases shareholder wealth. Baker and Powell (2012) added that companies that distribute dividends will have low earnings reinvestment are supposed to have a high firm value.

Firm value can be reflected in a firm's capability to pay dividends. The distribution of dividends influences firm value: the higher the dividends, the higher the firm value. Firms have to allocate their profit productively and effectively in order to achieve two different purposes; namely, increasing earnings reinvestments, and paying dividends. On one side firms' shareholders need to receive high dividends, on the other side companies want to keep their earnings high in order to reinvest their earnings unimpeded. A firm with good decision making in the area of earnings reinvestment and paying dividends is able to maximise its value.

Nevertheless, this study identified the relationship between the delta of earnings reinvestment and the delta of firm value by p value, which was higher than 5%, as shown in tables 6.27 and 6.28 respectively. This means that the delta of earnings reinvestment had an insignificant association with the delta of firm value and connotes that the delta of earning reinvestments did not increase the delta of firm value therefore the result is not in line with Baker and Powell (2012). Therefore, the eleventh hypothesis (H11) that supposes there is a positive association between the delta of firm value and the delta of earnings reinvestment is rejected.

The association between the delta of firm value and the delta of risk disclosure in listed banks

The findings of this research show a negative insignificant relationship between the delta of risk disclosure and the delta of firm value, which is reflected in the p value > 0.05 , as indicated in table 6.27. This result indicates that the delta of risk disclosure did not have an association with the delta of firm value.

Risk information is important for stakeholders. Risk disclosure is a medium of firm accountability for stakeholders, to send information about its performance, because investors need to predict risk before making decisions. Jensen and Meckling (1976) asserted that listed banks that disclose their performance to a greater extent tend to decrease agency conflict between managers and users and will give a positive impression to investors, thereby increasing firm value. Besides, listed banks have regulations to report their performance completely, comprehensively and regularly due to their listing on the stock market, in order to allow investors and potential investors to easily understand financial reports and find them useful for consideration before making less risky financial decisions. When companies send good signals in their reports transparently, investors are more likely to buy their shares and induce a share price increase, therefore increasing firm value. However, this study shows that the delta of risk disclosure has an insignificant relationship with the delta of firm value, as presented in table 6.27. Furthermore, risk disclosure was not found to affect firm value, as shown in table 6.28. This result is in accordance with Wang et al. (2013) who attested that risk disclosure did not increase firm value. They mentioned that this may be because managers are reluctant to report their performance transparently due to what they consider to be the disadvantages of disclosure. Since this study did not find any association between the delta of risk disclosure and the delta of firm value in listed banks, the twelfth hypothesis (H12) is rejected.

Table 6.27 The Pearson's Correlation of listed banks

	ASSETS	LDR	ROE	LEVERAGE	EARNINGREIV	RISKDISC	FIRMVALUE
ASSETS	1						
LDR	0.092 (0.327)	1					
ROE	-0.013 (0.893)	-0.040 (0.668)	1				
LEVERAGE	-0.074 (0.429)	-0.075 (0.421)	0.111 (0.234)	1			
EARNINGREIV	0.150 (0.109)	-0.169 (0.070)	-0.018 (0.851)	0.000 (0.993)	1		
RISKDISC	0.086 (0.357)	0.082 (0.382)	0.041 (0.660)	-0.100 (0.285)	-0.074 (0.430)	1	
FIRMVALUE	-0.027 (0.772)	-0.039 (0.679)	0.888** (0.000)	0.165 (0.077)	0.001 (0.988)	0.047 (0.615)	1

P-values are given in parentheses. The number of observations is 116. **. Correlation is significant at the 0.01 level (1-tailed). *. Correlation is significant at the 0.05 level (1-tailed).

Table 6.28 Summary of the Result of Multiple Regression for Firm Value in Listed banks

Variables	s	t	Sig t	Hypothesis
Assets	-0.017	-0.372	0.711	H7:Rejected
LDR	0.005	0.117	0.907	H8:Rejected
ROE	0.880	20.071	0.000	H9:Accepted
Leverage	0.068	1.545	0.125	H10:Rejected
Earnings Reinvestment	0.022	0.487	0.627	H11:Rejected
Risk Disclosure	0.020	0.461	0.645	H12:Rejected
Adjusted R square = 0.783 F= 70.023 F table(6;115) = 2.18 Fsig = 0.000 DW = 1.711				H13:Accepted

Source: adopted from SPSS

The association between the delta of firm value and the delta of firm characteristics and the delta of risk disclosure in listed banks

One of the most significant findings to emerge from this study is that adjusted R square for Model 2 is 0.783, as presented in table 6.28. This result means that about 78.3% of firm value can be explained by firm size (assets), liquidity (LDR), profitability (ROE),

leverage, earnings reinvestment, and risk disclosure; while 22.7% might be explained by other factors. The second major finding was that the multiple regression analysis revealed that F was 70.023, as shown in table 6.28. This signifies that the aggregate delta of risk disclosure and the delta of firm characteristics significantly influenced the delta of firm value, and the delta of profitability was the highest factor.

Listed banks which provide annual reports in order to disclose more of their performance will boost their firm value. This study is in line with agency theory which theorises that by revealing risk performance transparently in the annual report and giving good signals to users, agency conflict between users and managers is minimised, hence increasing firm value. Therefore, the association between the delta of risk disclosure and the delta of firm characteristics and the delta of firm value in listed banks is significant and reflected by the adjusted R square (78.3%) and F (70.023). All in all, the association between the delta of risk disclosure and the delta of firm characteristics and the delta of firm value in listed banks was significant, which means that the hypothesis (H13) is accepted.

The value relevance of risk disclosure in listed banks

This study shows that risk disclosure had an insignificant relationship with firm value, which was reflected by p value 0.582 as presented in table 6.26. Because the association between risk disclosure and firm value was insignificant, therefore risk disclosure in the listed banks' annual reports was not value relevant for users.

Detailed and transparent company information is needed by shareholders who want less risk in deciding whether to buy shares. By disclosing more detailed and accurate information, an annual report becomes more fruitful and value relevant for investors.

Agency theory asserts that companies which provide more transparent information are able to minimise information asymmetry between managers and users. However, in this study, risk disclosure in annual reports in listed banks as a source of information for making financial decisions did not increase firm value. Therefore the fourteenth hypothesis (H14) that supposes risk disclosure is value relevant for stakeholders is rejected. This result supports the findings of Kravet and Muslu (2013), who argued that risk disclosure is a boilerplate and it is not value relevant for stakeholders. Finally, the fourteenth hypothesis (H14) that supposes that risk disclosure is value relevant for stakeholders is rejected.

6.7.3 RQ 4.3 The value relevance of risk disclosure in unlisted banks

The results of the relationship between the delta of firm characteristic and the delta of risk disclosure and the delta of firm value are demonstrated in tables 6.29 and 6.30.

The association between the delta of firm value and the delta of firm size in unlisted banks

Table 6.29 shows there was an association between the delta of firm value and the delta of assets, which had a p significance of 0, and had a positive coefficient. This means that the delta of firm value in unlisted banks had a significant positive association with the delta of bank size. This association is strengthened by the results of the regression in table 6.30, which shows a significant influence of assets on firm value.

This result is in line with Watts and Zimmerman (1983) who attested that in agency theory, big companies have the financial resources to pay consultants to produce more

transparent firm performance reports in order to minimise agency conflicts between stakeholders and managers, and finally boost firm value. Moreover, McKinnon (1993) mentioned that companies want to show their capability to prove that firms with high assets are strong enough to cover their risks; therefore, they send good signals and gain a good image from stakeholders, hence increasing firm value. This condition is also shown by the fact that firm value of unlisted banks in this study was measured by Black Scholes Merton model, whereby the volatility of assets is calculated as equity deducted by liabilities, and assets were found to be an important factor driving firm value. Because of this, the seventh hypothesis (H7) that supposes there is a positive association between the delta of firm value and the delta of firm size is accepted.

The association between the delta of firm value and the delta of liquidity in unlisted banks

The relationship between the delta of firm value and the delta of liquidity has a p value of 0.004 (table 6.29). It means that individually the delta of liquidity has an association with the delta of firm value. However, the regression result did not support the association because table 6.30 shows that the delta of liquidity did not influence unlisted banks in reporting risk in more detail.

Previous researchers Al-Akra and Ali (2012) support this result because they also found an insignificant relationship between firm value and liquidity. The result indicates that whether unlisted banks had either high or low liquidity did not have an effect on increasing firm value. Moreover, LDR was not relevant for users in consideration of firm value. This may be because the main function of banks is to be a financial intermediary and money

creator, the success of which is measured by how much a bank lends in credits and creates as money in the liabilities side at the same time, and the condition tested did not make the firm value increase. Hence, the eighth hypothesis (H8) that supposes there is a positive association between the delta of firm value and the delta of liquidity is rejected.

The association between the delta of firm value and the delta of profitability in unlisted banks

The results in table 6.29 demonstrate that the delta of firm value and the delta of profitability had a statistically insignificant association. The empirical evidence regarding the influence of the delta of profitability to the delta of firm value is in table 6.30, which shows an insignificant relationship.

Uyar and Kiliç (2012) mentioned that firm value can be influenced by profitability. Stakeholders perceive that profit from sales and investment can generate a high profitability ratio. Rising profits from year to year shows the company's net income increasing and it indicates that the value of the company rises. Nevertheless, the results of this study were not in line with previous research. All in all, the result of regression did not support the ninth hypothesis (H9) and it can be concluded that there is an insignificant association between the delta of firm value and the delta of profitability in unlisted banks, hence the ninth hypothesis (H9) is rejected.

The association between the delta of firm value and the delta of leverage in unlisted banks

The relationship between the delta of firm value and the delta of leverage in this study is shown by p value 0.53 (table 6.29). This demonstrates that the delta of leverage in unlisted banks did not have an association with the delta of firm value. Table 6.30 also indicates that the delta of leverage did not affect the delta of firm value in unlisted banks. Highly leveraged firms with might face higher risk because leverage can be connoted with a threat of bankruptcy, which can make stakeholders worried. Moreover, the creditors of such banks also have to deal with a high level of risk, which can lead to agency problems and finally has a negative effect on firm value. This condition is not confined to unlisted banks; indeed, banks in general tend to be highly leveraged because their main sources of funds are from debt, namely from third parties (current account, saving and time deposit) and second parties (debts from other financial institutions); hence they find it difficult to raise firm value. Moreover, Hassan et al. (2009); Rajab and Handley-Schachler (2009) also found that leverage and firm value did not have a significant relationship. Due to this, the study rejects the tenth hypothesis (H10) that supposes there is a negative association between the delta of firm value and the delta of leverage.

The association between the delta of firm value and the delta of earnings reinvestment in unlisted banks

The relationship between the delta of firm value and the delta of earnings reinvestment in table 6.29 shows a p value of 0.254, indicating that the delta of earnings reinvestment did not have a significant association with the delta of firm value. The delta of earnings reinvestment also did not affect the delta of firm value, as shown in table 6.30.

The shareholders' aim when investing their funds in a company is to earn dividends and to increase their wealth. Meanwhile, when companies distribute high dividends, it supposes increasing firm value. Dividend policy is a crucial consideration for companies when they have to decide whether they will distribute dividends or retain their earnings. When firms prefer not to distribute dividends it means earnings are retained to add to their capital or for investing in other profitable business.

The relationship between firm value and earnings reinvestment in tables 6.29 and 6.30 demonstrates that earnings reinvestment did not have a significant association with firm value. In this study, most unlisted banks during the period of research preferred to retain their earnings for expanding their business, meaning that shareholders did not consider earnings reinvestment policy when valuing these firms.

This study is in accordance with Miller and Modigliani (1961) who mentioned that dividend policy does not have an effect on firm value and cost of capital; however, firm value is only be determined by the ability of a firm to generate profits and manage business risk. Due to dividend policy not having an effect on firm value, along with that, earnings reinvestment also does not affect firm value. Therefore, the eleventh hypothesis (H11) that supposes there is a positive association between the delta of firm value and the delta of earnings reinvestment is rejected.

The association between the delta of firm value and the delta of risk disclosure in unlisted banks

The findings of this research provide evidence of a positive insignificant relationship between the delta of risk disclosure and the delta of firm value, which is reflected by p

value > 0.05, as indicated in table 6.30. It connoted that the delta of risk disclosure did not affect the delta of firm value. Therefore, the twelfth hypothesis (H12) that supposed there is a positive association between the delta of risk disclosure and the delta of firm value is rejected.

Even though the trend of risk disclosure in unlisted banks increased, this did not grow their firm value. This result is not in line with agency theory, Sheu et.al (2010) and Jensen and Mecking (1976) who asserted that firms that disclose more will decrease information asymmetry between managers and users, and finally this increases firm value. This results may be due to multiple factors that can affect firm value and it is not merely risk-disclosure variable.

Table 6.29 The Pearson correlation between the delta of firm characteristics, the delta of risk disclosure and the delta of firm value in unlisted banks.

	ASSETS	LDR	ROE	LEVERAGE	EARNINGREIV	RISKDISC	FIRMVALUE
ASSETS	1						
LDR	0.277** (0.000)	1					
ROE	-0.014 (0.424)	0.149* (0.019)	1				
LEVERAGE	0.211** (0.002)	0.403** (0.000)	0.228** (0.001)	1			
EARNINGREIV	0.156* (0.015)	0.216** (0.001)	0.250** (0.000)	0.236** (0.000)	1		
RISKDISC	0.062 (0.193)	0.127* (0.038)	-0.094 (0.094)	0.210** (0.002)	0.049 (0.249)	1	
FIRMVALUE	0.486** (0.000)	0.186** (0.004)	0.012 (0.432)	0.116 (0.053)	0.048 (0.254)	0.056 (0.216)	1

P-values are given in parentheses. The number of observations is 196. **. Correlation is significant at the 0.01 level (1-tailed). *. Correlation is significant at the 0.05 level (1-tailed).

Table 6.30 Summary of the Result of Regression Firm Value in Unlisted Banks

Variables	s	T	Sig t	Hypothesis
Assets	0.477	7.136	0.000	H7:Accepted
LDR	0.061	0.852	0.395	H8:Rejected
ROE	0.026	0.382	0.703	H9:Rejected
Leverage	-0.010	-0.139	0.890	H10:Rejected
Earnings Reinvestment	-0.045	-0.670	0.504	H11:Rejected
Risk Disclosure	0.026	0.393	0.694	H12:Rejected
Adjusted R square = 0.218 F = 10.058 F table (6;165) = 2.24 F sig = 0.000 DW = 2.456				H13:Accepted

Source: adopted from SPSS

The association between the delta of firm characteristics and the delta of risk disclosure and the delta of firm value in unlisted banks

Table 6.30 shows that $F (10.058) > F \text{ table}$, which indicates that the relationship between the delta of risk disclosure and the delta of firm characteristics aggregated with the delta of firm value is significant. Furthermore, the adjusted R square for Model 2 was 0.218. This means that about 21.8% of the delta of firm value is explained by the delta of firm size, liquidity, profitability, leverage, earnings reinvestment, and risk disclosure, and the rest might be explained by other factors which were not tested in this research. Moreover, the delta of assets was the only one of the firm characteristics that had a significant positive relationship with the delta of firm value, as stated in Model 2.

When aggregated, the delta of firm characteristics and the delta of risk disclosure, and the delta of firm value in unlisted banks, had a significant association, which means Model 2 is fit for predicting the association between the delta of firm value and the delta of risk disclosure and the delta of firm characteristics in unlisted banks. As a result, the association between the delta of risk disclosure and the delta of firm characteristics and

the delta of firm value in unlisted banks is significant, which means that the thirteenth hypothesis (H13) is accepted.

The value relevance of risk disclosure in unlisted banks

This study found that risk disclosure had an insignificant relationship with firm value, which was reflected by p value 0.188, as presented in table 6.26. Because the association between risk disclosure and firm value is insignificant, therefore risk disclosure in the listed banks' annual reports was not value relevant for users.

This means risk disclosure in unlisted banks' annual report did not boost firm value and was not useful to users. Sheu et al. (2010) and Jensen and Meckling (1976) mentioned that information asymmetry between managers and users can be minimised when the firms disclose and this increases firm value. By disclosing more detailed and accurate information, an annual report is considered to be more fruitful and value relevant for investors. In addition, this result contradicts with Gordon et al. (2010) who mentioned that in signalling theory, a firm sends signals to stakeholders through annual report is in order to increase firm value. This means that even when unlisted banks reported their risk more transparently in their annual reports, it did not significantly enhance firm value. The result is supported by Wang et al. (2013) who found that more voluntary disclosure did not boost firm value in China. This is explained by Brounen et al. (2007) who asserted that unlisted companies still lack transparency and multiple factors that can affect firm value. Finally, the fourteenth hypothesis (H14) that supposes that risk disclosure is value relevant for stakeholders is rejected.

6.7.4 RQ 4.4 The value relevance of risk disclosure in Islamic banks

As already mentioned above, firm value did not show a normal pattern, so the eleventh hypothesis was ignored and the delta of firm value was transformed into a Ln.

The relationship between the delta of firm value and the delta of firm size in Islamic banks

Table 6.31 shows that the association between the delta of firm value and the delta of bank size had a p value $0.028 < 0.05$. This means that the delta of firm value had a significant association with the delta of firm size. The result of regression in table 6.32 supports this evidence with a p value of 0.031.

This result is in accordance with agency theory, which states that large companies have strong finances which increase firm value. In their research, Uyar and Kiliç (2012) found that the size of a firm had a significant positive effect on the value of the firm. In addition, McKinnon (1993) explained that companies with large assets have a financial motivation to disclose more to show their strength in order to build a good image with stakeholders, which means large firms communicate good news better than small companies; hence, this condition helps to boost firm value.

Therefore, the seventh hypothesis (H7) that supposes a positive association between the delta of firm size and the delta of firm value is accepted.

The association between the delta of firm value and the delta of liquidity in Islamic banks

The relationship between the delta of firm value and the delta of liquidity has p value 0.458, which is higher than 0.05, as shown in table 6.31. This means that the delta of firm value did not have an association with the delta of liquidity. The delta of liquidity did not affect the delta of firm value in Islamic banks because p value was more than 0.05, as shown in table 6.32.

This result indicates that the rahibul maal of Islamic banks did not consider the delta of liquidity for valuing the firm and other factors to affect the value of the bank. This result is in accordance with Al-Akra and Ali (2012) who asserted there is no relationship between firm value and liquidity. Because of this, the eighth hypothesis (H8) that supposed a positive association between the delta of liquidity and the delta of firm value is rejected.

Table 6.31 The Pearson's correlation between firm characteristics, risk disclosure and firm value of Islamic banks

	ASSETS	LDR	ROE	LEVERAGE	RISKDISC	ln_firm
ASSET	1					
LDR	0.051 (0.800)	1				
ROE	-0.145 (0.469)	0.228 (0.252)	1			
LEVERAGE	-0.323 (0.100)	-0.126 (0.530)	0.122 (0.545)	1		
RISKDISC	-0.282 (0.154)	-0.314 (0.111)	-0.180 (0.369)	0.113 (0.574)	1	
ln_firm	0.480* (0.028)	0.171 (0.458)	0.050 (0.829)	0.119 (0.607)	-0.469* (0.032)	1

P-values are given in parentheses. The number of observations is 27. **. Correlation is significant at the 0.01 level (2-tailed). *. Correlation is significant at the 0.05 level (2-tailed).

Table 6.32 Summary of the Result of OLS Regression Firm Value in Islamic banks

Variables	S	T	Sig t	Hypothesis
ASSETS	0.589	2.377	0.031	H7:Accepted
LDR	0.028	0.141	0.890	H8:Rejected
ROE	-0.043	-0.211	0.835	H9:Rejected
LEVERAGE	0.434	1.860	0.083	H10:Rejected
RISK DISCLOSURE	-0.241	-1.090	0.293	H12:Rejected
Adjusted R square = 0.267 F = 2.457 F table (5;21) = 2.685 Fsig. = 0.081 DW = 2.318				H13: Rejected

Source : adopted from SPSS

The association between the delta of firm value and the delta of profitability in Islamic banks

The results in table 6.31 indicate that the association between the delta of firm value and the delta of profitability had a p value of 0.829. This result demonstrates that the delta of profitability had an insignificant relationship with the delta of firm value. The delta of profitability did not affect the delta of firm value, as indicated in table 6.32, where the p value is higher than 0.05. Signalling theory posits that highly profitable firms send good signals to stakeholders and this increases firm value. Conversely, the result did not agree with signalling theory because the delta of profitability did not result in an increase in the value of Islamic banks.

The statistical results indicate that the enhancement of firm value in Islamic banks was not affected by the delta of profitability, but may have been affected by other variables. Therefore, the ninth hypothesis (H9) that supposes there is a positive association between the delta of profitability and the delta of firm value is rejected.

The association between the delta of firm value and the delta of leverage in Islamic banks

The relationship between the delta of firm value and the delta of leverage in this study is shown by p value of $0.607 > 5\%$. This result shows that leverage had an insignificant relationship with firm value in Islamic banks. Moreover, in table 6.32 it can be seen that leverage did not affect firm value.

This result is supported by Uyar and Kiliç (2012) who attested that leverage did not have relationship with firm value. Indeed, the relationship between firm value and leverage is still vague. By contrast, Kouki and Said (2011) explained that high leverage reduces profits, and as a result shareholders' wealth declines and this induces a decline in firm value. Moreover, Korotkikh (n.d.) argued that debt causes financial distress, meaning a firm cannot pay its debts and this finally decreases firm value. The same researcher also mentioned that it is difficult to decide whether the relationship between leverage and firm value is a negative, positive or insignificant relationship because there are many factors that can act as the mediator in this association, such as corporate governance, manager behaviour, and taxes. The MM theory mentioned that leverage which increases firm value due to high debt reduces tax payment and boosts firm value. As a result, the tenth hypothesis (H10) that supposes there is a negative association between leverage and firm value is rejected.

The association between the delta of firm value and the delta of risk disclosure in Islamic banks

The finding of this research in table 6.32 shows a negative insignificant relationship between the delta of risk disclosure and the delta of firm value. The result indicates that the delta of risk disclosure did not have an association with the delta of firm value.

In order to attract investors, managers' report their performance in more detail to show that the company is a good investment. Revealing more detail about their condition can reduce agency problems and asymmetric information and send good signals to investors, thereby boosting firm value.

This research found a negative insignificant relationship between the delta of risk disclosure and the delta of firm value, which is reflected by $p \text{ sig } (0.293) > 0.05$, as indicated in table 6.32. This means that even though Islamic banks disclosed more of their risk in reports this did not boost firm value. This result is in accordance with (Wang, 2013) who examined the influence of voluntary disclosure on firm value and reported that an increase in disclosure in annual reports does not lead to the creation of value for a company. In the population of this study, the result may have been because firms were reluctant to report more detail because of the weaknesses of disclosure. Returning to the twelfth hypothesis posed at the beginning of this study, the result is obviously different. Therefore, the hypothesis (H12) is rejected.

The association between the delta of firm characteristics, the delta of risk disclosure and the delta of firm value in Islamic banks

Table 6.32 demonstrates that $F (2.457) < F \text{ table } (2.81)$ and $F \text{ sig}$ is more than 0.05. This result means that in aggregate, the delta of firm characteristics and the delta of risk disclosure did not affect the delta of firm value significantly.

Only the delta of assets had a positive relationship with the delta of firm value. The adjusted R square is 0.267, which implies that 26.7% of firm value is explained by the delta of firm size, liquidity, profitability, leverage and the delta of risk disclosure. Only the delta of assets had a positive relationship with the delta of firm value while the delta of liquidity, profitability, leverage, and risk disclosure did not have an association with firm value. Therefore, the model 2 was fit more predicting the correlation between the delta of firm characteristics and the delta of risk disclosure and the delta of firm value. However, when aggregated, the delta of firm characteristics and the delta of risk disclosure did not affect the delta of firm value, and the F test is smaller than F table and insignificant, therefore, the thirteenth hypothesis (H13) is rejected.

The value relevance of risk disclosure in Islamic banks

This study shows that risk disclosure had an insignificant relationship with firm value, which was reflected by p value 0.676 as presented in table 6.26. This means risk disclosure in the Islamic banks' annual reports was not value relevant, because risk disclosure did not increase firm value. This suggests that risk disclosure was not useful for rahibulmaal and mudharib, and other users. Islamic banks employ profit and loss sharing contracts, and in doing so they have to declare their performance transparently, thereby convincing stakeholders that the banks are acting fairly and abiding by sharia law. Moreover, particularly in profit and loss sharing arrangements, Islamic banks have to assure that they share their profit fairly between investors (shahibulmaal) and banks (mudharib). It can be supposed that Islamic banks will be more transparent in reporting their risk in order to grow the value of the firm. However, because the association between risk disclosure and firm value is insignificant this means that risk disclosure in

the Islamic banks' annual reports was not value relevant and useful for rahibulmaal, mudharib, and other users. To sum up, the fourteenth hypothesis (H14) that supposes risk disclosure is value relevant for stakeholders is rejected.

This study agree with Al-Akra and Ali (2012) and Hassan et al. (2009) who mentioned that voluntary disclosure has insignificant with firm value, but this contradicted with Sheu et al. (2010) and Jensen and Mecking (1976) who asserted that if the company is more transparent in describing their performance, it can decrease asymmetric information hence it increases its firm value.

6.7.5 RQ.4.5 The value relevance of risk disclosure in non-Islamic banks

The association between the delta of firm value and the delta of firm characteristics and the delta of risk disclosure can be explained as follows:

The association between the delta of firm value and the delta of firm size in non-Islamic bank

Table 6.33 shows that the association between the delta of firm value and the delta of firm size had a p value of 0.431 and 0.975 in table 6.34, which means that the delta of firm value had an insignificant association with the delta of firm size. The delta of assets in non-Islamic banks did not determine firm value. This condition shows that the delta of firm value of non-Islamic banks was affected by other factors. This result is not in line with signalling theory, which supposes large firms will deliver good signals to show their strength and increase firm value (Gordon et al., 2010). Therefore, the seventh hypothesis

(H7) that supposes there is a positive association between the delta of firm size and the delta of firm value is rejected.

The association between the delta of firm value and the delta of liquidity in non-Islamic banks

The relationship between the delta of firm value and the delta of liquidity had p value 0.387. This means that the delta of firm value did not have an association with the delta of liquidity. In addition, the delta of liquidity did not affect the delta of firm value, as shown in table 6.34. The result indicates that the delta of liquidity did not boost firm value; this may have been because LDR in this study was not a proper variable for supporting firm value. This ratio reflects liquidity in terms of the banks' capability to provide money from reserves to cover creditor withdrawals; nevertheless, the delta of liquidity did not have an impact on increasing firm value. This finding supports Al-Akra and Ali (2012), who also found that liquidity has an insignificant correlation with firm value. Therefore, the eighth hypothesis (H8) that supposes there is a positive association between the delta of liquidity and the delta of firm value is rejected.

The association between the delta of firm value and the delta of profitability in non-Islamic banks

The results in table 6.33 show that the association between the delta of firm value and the delta of profitability has a p value 0. The result indicates that the delta of profitability had a significant positive association with the delta of firm value. The regression result in table 6.34 supports the effect of the delta of profitability to firm value.

Shareholders perceived that highly profitable banks were able to manage themselves, hence generate more profit in the future meaning the value of the firm was likely to rise. In other words, highly profitable non-Islamic banks had a positive perception from users that made firm value increase. Moreover, Watson et al. (2002) asserted that based on signalling theory, highly profitable firms deliver good signals to users in order to boost their firm value. In addition, Uyar and Kiliç (2012) also found that profitability has a positive association with firm value. Therefore, the ninth hypothesis (H9) that supposes there is a positive association between the delta of profitability and the delta of firm value is accepted.

The association between the delta of firm value and the delta of leverage in non-Islamic banks

The relationship between the delta of firm value and the delta of leverage in this study is shown by $p \text{ sig. } 0.444 > 5\%$ in table 6.34. This result reflects that the delta of leverage had an insignificant relationship with firm value. This means that the delta of leverage did not boost the delta of firm value. This result is not in line with agency theory predictions that leverage has a relationship with firm value, but it is in accordance with Hassan et al. (2009); Uyar and Kiliç (2012) who found that leverage and firm value did not have a relationship. It is also in line with MM theory who mentioned that leverage increases firm value because high debt decreases tax payments and boosts firm value. Due to this, the tenth hypothesis (H10) that supposes there is a negative association between the delta of leverage and the delta of firm value is rejected

Table 6.33 The Pearson correlation between the delta of firm characteristics, the delta of risk disclosure and the delta of firm value non-Islamic banks

	ASSETS	LDR	ROE	LEVERAGE	EARNINGREIV	RISKDISC	FIRMVALUE
ASSETS	1						
LDR	0.054 (0.181)	1					
ROE	-0.005 (0.465)	0.019 (0.374)	1				
LEVERAGE	-0.144** (0.007)	0.295** (0.000)	0.115* (0.027)	1			
EARNINGREIV	0.071 (0.118)	0.179** (0.001)	0.044 (0.230)	0.157** (0.004)	1		
RISKDISC	0.055 (0.177)	0.148** (0.006)	0.000 (0.498)	0.083 (0.082)	0.031 (0.303)	1	
FIRMVALUE	-0.010 (0.431)	-0.017 (0.387)	0.860** (0.000)	0.108* (0.034)	-0.002 (0.484)	0.023 (0.352)	1

P-values are given in parentheses. The number of observations is 285. **. Correlation is significant at the 0.01 level (1-tailed). *. Correlation is significant at the 0.05 level (1-tailed).

Table 6.34 Summary of Regression between the delta of risk disclosure, the delta of firm characteristics and the delta of firm value

Variables	s	t	sig	Hypothesis
Assets	0.001	0.032	0.975	H7:Rejected
LDR	-0.038	-1.175	0.241	H8:Rejected
ROE	0.860	28.121	0.000	H9:Accepted
Leverage	0.025	0.767	0.444	H10:Rejected
Earnings Reinvestment	-0.038	-1.224	0.222	H11:Rejected
Risk Disclosure	0.027	0.877	0.382	H12:Rejected
Adjusted R square =0.738 F = 134.522 F table (6;278) = 2.131 Fsig = 0.000 DW = 1.681				H13:Accepted

Source: adopted from SPSS

The association between the delta of firm value and the delta of earnings reinvestment in non-Islamic banks

The relationship between the delta of firm value and the delta of earnings reinvestment in the table 6.33 provides evidence of a p sig. of 0.484, while the p value in table 6.34 is 0.222. This means that the delta of earnings reinvestment did not have an association with the delta of firm value. In other words, the delta of earnings reinvestment did not make firm value increase.

Bodie et al. (2011) argued that companies with high earnings reinvestment distribute small dividends, but in the future investors will receive high dividends, thereby increasing firm value (figure 4.1). Nevertheless, this research showed that the earnings reinvestment plans of non-Islamic banks did not enhance firm value. It means that firm value did not increase merely because of earnings reinvestment plan. Therefore, the eleventh hypothesis (H11) that supposes there is a positive association between the delta of earnings reinvestment and the delta of firm value is rejected.

The association between the delta of firm value and the delta of risk disclosure in non-Islamic banks

The findings of this research provide an insignificant relationship between the delta of risk disclosure and the delta of firm value, which is reflected by p value > 0.05, as indicated in table 6.34.

This means that even when non-Islamic banks explained their risk performance more transparently it did not increase firm value. This result contradicts signalling theory, which suggests that companies that disclose more risk send good signals for users and that supports an increase in firm value. However, this research is supported by Al-Akra and

Ali (2012); Hassan et al. (2009) who asserted that voluntary disclosure has an insignificant relationship with firm value.

This result is not in accordance with Sheu et al. (2010) and Jensen and Meckling (1976) who asserted information asymmetry between managers and users can be minimised by disclosing firm performance more transparently, and finally this increases firm value. The insignificant relationship between those variables in non-Islamic banks may be due to multiple factors that can affect disclosure. Therefore, the twelfth hypothesis (H12) that supposed there is a positive association between the delta of risk disclosure and the delta of firm value is rejected.

The association between the delta of firm characteristics and the delta of risk disclosure and the delta of firm value in non-Islamic banks

Table 6.34 demonstrates that $F(134,522) > F_{table}(6.278)$. This means that the delta of firm characteristics and the delta of risk disclosure affected the delta of firm value significantly. This finding is supported by adjusted R square, where the association between the delta of firm value and the delta of firm characteristics and the delta of risk disclosure is 0.738, implying that the delta of firm characteristics, namely: firm size; liquidity; profitability; leverage; earnings reinvestment; and the delta of risk disclosure, explain approximately 73.8% of the delta of firm value and 26.2% was affected by other factors that were not tested in this study. This finding means that the firm value of non-Islamic banks was not affected by only one factor but by aggregates of some variables. Model 2 was fit for predicting the factors affect the delta of firm characteristics, and the delta of risk disclosure and the delta of firm value. Finally, the thirteenth hypothesis (H13)

that supposes an association between the delta of risk disclosure and the delta of firm characteristics, and the delta of firm value is accepted.

The value relevance of risk disclosure in non-Islamic banks

This study shows that risk disclosure had an insignificant relationship with firm value, which was reflected by p value 0.742 as presented in table 6.26. Because the association between risk disclosure and firm value was insignificant, therefore risk disclosure in the listed banks' annual reports was not value relevant to users.

This means that risk disclosure in the non-Islamic banks' annual report was not value relevant, it did not increase firm value, and it was not useful for stakeholders. Therefore, the fourteenth hypothesis (H14) that supposes risk disclosure to be value relevant for stakeholders must be rejected.

Overall, it can be concluded that the risk information in the annual reports issued by all banks, listed and unlisted banks, Islamic and non-Islamic banks, did not meet the stakeholders' needs and interests. This indicates that the annual reports in the Indonesian banks still lack information and they are not really transparent.

If agents offer complete information, readers of annual reports can use the information to make an investment decision and thus the information is value relevant for users and it will ultimately increase firm value. Instead, because managers have their own interests, they can sometimes withhold information and fail to convey information more transparently (nondisclosure). Thereby, the investors cannot obtain the necessary information that would affect their investment decision.

Banks were unwilling to report their condition in more detail because giving information transparently has several disadvantages. First, by disclosing the company's information, it could expose their strategies to the competitors and even decrease their competitive advantages (Darrough, 1993); Subramanian and Reddy (2012); (Elliott & Jacobson, 1994). In addition, Bhasin (2012) mentioned that even though disclosure in human resources or risk information is able to minimise asymmetrical information, it puts a company at risk by exposing its marketing strategies, research and development or technology in its annual reports.

Second, when they read product development plans in an annual report, competitors are able to produce similar products or services or counter products; the competitors may even produce the product better (Elliott & Jacobson, 1994). Third, reporting a company's performance completely will increase costs and consequently, this increases product prices and influences profit and the company's performance (Elliott & Jacobson, 1994). Admati and Pfleiderer (2000) mentioned some of the costs that can appear due to reporting a firm's performance in more detail, namely the costs of producing, disseminating, and auditing information.

Fourth, this study's findings suggest that not only were banks aware of the consequences of risk disclosure, they also demonstrate that banks in Indonesia still had a low willingness to explain their performance transparently. This is also supported by Suhardjanto, Dewi, Rahmawati, and Firazonia (2012) who asserted that even though there were mandatory regulations to obligate banks to reveal their performance more transparently, the level of disclosure of banks in Indonesia was still low. Moreover, the result is strengthened by PricewaterhouseCoopers (2000) who ranked Indonesia the

lowest for transparency and disclosure compared with other countries in the Asian market. Finally, PricewaterhouseCoopers (2008) found that even though banks must report their performance based on regulations, (such as adopting IFRS, Basel), they still did not reveal their condition completely. It is therefore understandable that when there was difficulty in reading and comparing their information, it was not relevant for users.

Moreover, based on research in China by Yuen et al. (2009) the existence of an audit committee can push managers not to disclose a company's performance, by suggesting that managers disclose only enough to fulfil the regulations. In addition, Oxelheim (2008) argued that the more information is delivered by companies, and the more information received by users, the higher the possibility that stakeholders will become confused; therefore, there should be an optimal point to allow firms to decide what is sufficient information that is value relevant for users, and not detrimental of the firm. By contrast, Anandarajan et al. (2011) argued that firm disclosure influences value relevance and is more significant when it is supported by regulations, such as adoption of IFRS (Kar in, 2013), whereby it becomes more valuable to stakeholders.

The relationship between risk disclosure and firm value had spurious result and might not exist because: first, the exercise was over fitting and out of sample. This might be more than 31.2% of annual report banks were excluded due to could not being downloaded, blank, damaged, and were not available. In addition, this research refers to the use of risk keywords and the previous research's model, but in a different environment; therefore it did not work in this study. Presumably they used banks in the UK as their sample data that was done by Linsley and Shrives (2006); while (Brounen et al. (2007) had done it in Europa, and banks in US, UEA, Egypt had been done by Hassan

et al. (2009), but this study surveyed the Indonesian market, which might have different conditions.

Second, it is possible managers had different concepts of risk and it does not come up with focusing of the concept of the risk. From a finance point of view, risk drives the value of the firm, and the managers recognised the volatility of risk but they demonstrated this risk to shareholders in ways that were less useful. The managers delivered the risk by clustering risk keywords and they constructed the risk articulated by risk keywords. The nature of risk is that investors recognise the outcomes and make judgements based on history and past evidence. Formal risk is measured by the volatility of value of a firm, and investors are interested in how risky the firm's assets are and how this will affect the volatility of the value of the firm.

A research is based upon the former and the results need to be interpreted accordingly. Financial accounting does not completely reveal what the value of a firm is and what its assets are. Managers should seek to describe risk which is measured by the value of the firm's underlying assets. While risk keywords come with literature are not apparently targeting, focusing on the concept or risk that investors really interested in.

Moreover, managers did not actually act in ways that the stakeholders needed and they did not explain risk in their annual report in more detail, because the managers were conscious of the consequences of disclosure. In addition, the audit committee can push the manager not to report their performance fully. This means that communication between managers and shareholders could be disturbed by noise such as moral hazard,

adverse selection or attentiveness. Finally, the fourteenth hypothesis (H14) that supposes that risk disclosure is value relevant for stakeholders is rejected.

Based on the statistical results, the statistical coefficient correlation between risk disclosure and firm value was insignificant in all banks, listed, unlisted, Islamic and non-Islamic banks. This indicates that annual reports were not sending effective signals and information to investors. Moreover, annual reports might not an effective medium of communication for explaining risk by banks to stakeholders; therefore, the annual reports did not meet stakeholders' interests. This indicates that the risk disclosure in annual reports was not value relevant for stakeholders and did not affect firm value. The summary of the hypotheses' results is represented in table 6.35.

Table 6.35 The resume of hypotheses

Hypotheses	All banks	Listed	Unlisted	Islamic	Non-Islamic
H1	R	R	R	R	R
H2	R	R	R	R	A
H3	R	R	R	R	R
H4	R	R	A	R	R
H5	R	R	R	NT	R
H6	R	R	A	R	R
Adj. R square	0.005	-0.015	0.044	0.047	0.009
F	1.289	0.668	2.816	1.323	1.535
H7	R	R	A	A	R
H8	R	R	R	R	R
H9	A	A	R	R	A
H10	R	R	R	R	R
H11	R	R	R	NT	R
H12	R	R	R	R	R
H13	A	A	A	R	A
H14	R	R	R	R	R
Adj. R square	0.709	0.783	0.218	0.267	0.738
F	127.402	70.023	10.058	2.457	134.522

R= rejected A= accepted NT= not tested

6.8 Summary

Even though the trend of risk disclosure increased, nevertheless risk information in the annual reports was not value relevant for stakeholders. The banks were reluctant to disclose their performance in more detail. This might be because the managers kept the information, and did not transparently explain firm conditions due to fearing of the consequences of disclosure. This reflects that communication between banks (managers) and stakeholders was disturbed by noise, as illustrated in figure 3.3.

The managers did not report transparently due to a variety of reasons. First, reporting firm performance in more detail increases costs. When costs increase, it influences profit and finally affects firm performance. Second, competitors can read their strategies and even produce similar or better quality products or services (Okctabol, 1993). Third, the audit committee can influence managers not to report in more detail and only to fulfil the regulations (Yuen et al., 2009). Annual reports did not effectively send signals and information to stakeholders. This means annual reports were not an effective medium for communicating risk between banks and stakeholders.

The result of adjusted R square and F demonstrated that the correlation between the delta of risk disclosure and the delta of firm characteristics and the delta of firm value in listed banks was stronger than unlisted banks, while the non-Islamic banks had a stronger association than Islamic banks.

CHAPTER 7

CONCLUSION

This chapter provides a conclusion of the results to answer the research questions. Underpinning theories and practical implications will be highlighted, and afterwards the limitations of this research and suggestions for future research will be presented.

7.1 Conclusion

The purpose of this research is to analyse the association between the determinants and the value relevance of risk disclosure in the Indonesian banking sector, which is derived into four research questions. This study was carried out to answer four research questions, which are explained below:

RQ1: How can the extent of risk disclosure in the Indonesian banking sector be effectively quantified?

The study has key findings, which include the fact that generally the average number of Indonesian risk keywords between 2008 and 2012 demonstrated an upward trend, for all banks and all sectors. The listed banks had the highest average number of risk keywords in each year studied. Meanwhile, non-Islamic banks had a higher average number of risk keywords than Islamic banks.

The most obvious finding to emerge from this research was the large gap that fluctuated between the lowest and the highest number of Indonesian risk keywords, demonstrating that the content and total number of risk keywords in annual reports had a large variation. The data strongly suggest that several banks in Indonesia were unwilling to describe the

risks they faced in their annual report in more significant detail, for example, some used fewer than 100 risk keywords.

The number of Indonesian sentences in the annual reports of all banks throughout the period 2008 to 2012 showed a significant increase, although in 2009 the number of sentences decreased, but then in 2010 climbed sharply again. The listed banks always demonstrated the highest number of sentences in every year. Meanwhile non-Islamic banks always had a higher number of total Indonesian sentences than Islamic banks.

The large gap between the lowest and the highest numbers of risk keywords, sentences and risk disclosure in every year in all banks demonstrates that banks had many variations when explaining their performance. Risk disclosure of all banks and each sector between 2008 and 2012 increased overall but also slightly fluctuated year-to-year. The trend in the extent of risk disclosure demonstrated went up, even though in 2011 the extent of risk disclosure declined slightly, it increased again in 2012.

Despite the listed banks having a higher number of risk keywords and number of sentences than unlisted banks, unlisted banks had a higher risk disclosure than listed banks. Between 2008 and 2011, Islamic banks had a lower risk disclosure than non-Islamic banks; nevertheless, in 2012 Islamic banks increased dramatically and recorded a higher risk disclosure than non-Islamic banks. However, the average risk disclosure of Islamic banks over the whole study period was still lower than non-Islamic banks.

The average risk disclosure in all banks showed an upward trend. The risk disclosure for listed banks rose gradually, and even though in 2011 it saw a slight decrease, it went up sharply in 2012. Those movements signified that listed banks were attempting to report

their performance with a greater degree of disclosure, not only because of their obligations in the regulations of their listing on the stock market, but also in order to attract investors. Moreover, they had more stakeholders who paid attention to what the banks had done, their prospects in the future, and their risk profile, and took this into consideration before making decisions.

The average risk disclosure for the unlisted banks was higher than listed banks and it went up in the years 2008 to 2010 before falling in 2011; however, after this it increased again in 2012. This indicates that the unlisted banks were trying to reveal their performance more transparently. The Islamic banks had a widely fluctuating average risk disclosure; however, the overall trend was upward. In 2008-2009, the average risk disclosure for Islamic banks climbed sharply, then increased slightly in 2010, after that dropped dramatically in 2011, before subsequently climbing sharply again in 2012.

The average risk disclosure of non-Islamic banks increased slightly during 2008 to 2010, and dropped in 2011; however, the trend was generally upward. Even though the numbers were always higher than for Islamic banks every single year, in 2012 the extent of risk disclosure was lower than for Islamic banks. However, the average risk disclosure for non-Islamic banks from 2008 to 2012 was higher than for Islamic banks.

A final point to note is that the trend of risk disclosure in the Indonesian banking sector was upward. This means that the banks were trying to report their risk performance more transparently every single year. In addition, the unlisted banks had a higher average of risk disclosure than listed banks, while non-Islamic banks had a higher average risk disclosure than Islamic banks, except in 2012.

This condition is in line with signalling and agency theories which mention that asymmetric information and adverse selection can appear between managers and stakeholders. This can happen because the managers have more information than stakeholders (Vitezic, 2011); they have their own commitment and interests, even moral hazard (Teece, 1996; McAfee and McMillan, 1987), along with that the managers may have an intention not to report their performance more transparently. Octabol (1993) asserted that in a condition of competition, a company may not disclose to hide the true condition of their performance. In addition, Mohobbot (2005) and Lajili and Zaghali (2005) argued that the content and level of reporting of risk in the annual reports has large variations.

RQ 2: Are there differences between the extent of risk disclosure practice between listed banks and unlisted banks, and Islamic banks and non-Islamic banks?

The major finding here was based on Levene's test; the delta of risk disclosure between listed and unlisted banks was no different, even though the mean of the delta of risk disclosure in unlisted banks was higher than listed banks. Meanwhile, the delta of firm value in listed banks was higher than unlisted banks, but Levene's test showed that the delta of firm value of listed and unlisted banks was not different.

The mean of the delta of risk disclosure Islamic banks was higher than non-Islamic banks, but Levene's test showed that there is no differences between the delta of risk disclosure in Islamic and non-Islamic banks. In addition, the mean delta of firm value of non-Islamic banks was higher than Islamic banks, while the delta of firm value in the Islamic and non-Islamic banks are the same.

The results is not in accordance with Cerf (1961) who asserted that listed companies are required to report their performance more than unlisted companies. It is also contradict with agency theory which mentioned that in order to minimise asymmetric information between managers and stakeholders and reduce agency costs, large companies will explain the information more transparent in the annual report than small companies (Watt & Zimmerman, 1983; Inchausti, 1977). The results contradicts Wallace et al., (1994) and Aljifri et al. (2014) who explained that listed companies are expected to disclose more in reporting their performance than unlisted companies.

The result is not in line with Ariffin (2005); Baydoun and Wullelett (2000) who mentioned that Islamic banks are required to be transparent compared to conventional banks due to Islamic banks having more complex transaction and employing PLS.

RQ 3: What factors affect a bank's decision to disclose risk?

The conclusion in answering the third research question about the factors affecting banks' decisions to disclose risks are as follow:

In all banks, the delta of assets, LDR, ROE, leverage, and earnings reinvestment had an insignificant correlation with the delta of risk disclosure. Firm characteristics did not explain risk disclosure. When aggregated, the delta of firm size, liquidity, profitability, leverage and earnings reinvestment were not found to influence the delta of risk disclosure. Accordingly, Model 1 was not fit for explaining the factors affecting banks' decisions to report their risks more transparently, and other factors that were not tested in this study might have been affecting banks in offering more risk disclosure. As a result, H1, H2, H3, H4, H5, and H6 for all banks were rejected.

In the listed banks, the delta of firm size, liquidity, profitability, leverage, and earnings reinvestment individually did not have an association with the delta of risk disclosure. The firm characteristics did not affect banks to report risk in more detail. Model 1 was not fit for explaining factors that influenced the Indonesian listed banks in disclosing more of their risk in their reports. Finally, H1, H2, H3, H4, H5, and H6 for listed banks were rejected.

In the unlisted banks, individually the delta of profitability had a significantly negative association with the delta of risk disclosure. The delta of risk disclosure also had a positive significant relationship with leverage; nevertheless, it did not have a relationship with delta assets, liquidity, and earnings reinvestment. The delta of risk disclosure in unlisted banks could not be explained by delta of firm size, liquidity, profitability, leverage, or earnings reinvestment. The delta of risk disclosure had a significant association with the aggregated delta of firm characteristics. Model 1 was fit for predicting the factors affect the delta of risk disclosure. This study rejected H1, H2, H3, and H5, for unlisted banks.

The statistical results indicated that none of the delta of the firms' characteristics influenced the delta of risk disclosure in Islamic banks. The delta of firm characteristics did not determine risk disclosure. The delta of firm characteristics did not influence the delta of risk disclosure. Model 1 was not fit for Islamic banks in predicting factors affecting banks when reporting risk in their annual report. As a result, H1 to H6 were rejected for Islamic banks.

In the non-Islamic banks, the delta of liquidity had a significant positive relationship with the delta of risk disclosure, but none of the delta of firm characteristic variables were significant in affecting the delta of risk disclosure. The delta of risk disclosure could not be explained by the delta of firm size, liquidity, profitability, leverage, and earnings reinvestment, but it might by other variables. The delta of firm characteristics did not affect non-Islamic banks in reporting risks more transparently. As a result, H1, H3, H4, H5 and H6 were rejected. Model 1 was not fit for non-Islamic banks for predicting factors affecting non-Islamic banks in the reporting of risk in their annual reports.

The result is not in accordance with agency and signalling theories because almost all the hypotheses are rejected. Agency theory which mentioned that large companies will disclose more in their annual report than smaller companies (Watts and Zimmerman, 1983); Inchausti (1997). Marshall and Weetman (2007) attested that based on signalling theory, firms with high liquidity will disclose more in their reports. Signalling theory suggested that profitable companies are more transparent in reporting their performance (Inchausti, 1997). Jensen and Meckling (1976) suggested that highly level leveraged companies provide information in more detail.

RQ 4: What is the value relevance of risk disclosure in listed banks, unlisted banks, Islamic banks, and Non-Islamic banks?

For Model 2 in all banks, only the delta of profitability had a significant association with firm value, while individually the delta of assets, liquidity, leverage, earnings reinvestment, and the delta of risk disclosure did not influence firm value. The statistical result showed that by the delta of assets, ROE, leverage, risk disclosure, all of which had

a positive sign. The result showed that 70.9% of the delta of firm value is explained by the delta of size, liquidity, profitability, leverage, earnings reinvestment and the delta of risk disclosure, while 29.1% was explained by other factors.

The aggregated the delta of firm characteristics and the delta of risk disclosure in all banks significantly affected the delta of firm value. All banks with an aggregation of high assets, a low LDR, a high ROE, a high leverage, a small earnings reinvestment and a high risk disclosure correlated with an increase in firm value, for all kinds of banks. Hence, H7, H8, H10, H11 H12 were rejected, meanwhile H9 and H13 were accepted. However, model 2 was fit for testing factors that affected firm value in all banks.

There was a positive relationship between delta of profitability and the delta of firm value; meanwhile, the delta of assets, liquidity, leverage, earnings reinvestment and risk disclosure had an insignificant association with firm value in listed banks. The delta of assets, LDR, ROE, leverage, earnings reinvestment and risk disclosure explained 78.3% of firm value, and the remaining 21.7% was explained by other variables. The aggregation of small delta assets, a high delta LDR, ROE, leverage, earnings reinvestment, and the delta of risk disclosure increased the delta of firm value in the listed banks. Model 2 was fit for examining firm value of listed banks by factors, namely the delta of firm size, liquidity, profitability, leverage, earnings reinvestment and risk disclosure. All in all, H7, H8, H10, H11, and H12 were rejected, while H9 and H13 were accepted.

Individually, only the delta of assets had a significant positive association with the delta of firm value. The relationship between the delta of firm characteristics and the delta of

risk disclosure, and the delta of firm value in Model 2 for unlisted banks was shown by an adjusted R square result of 0.218. This indicated that firm size, liquidity, profitability, leverage, earnings reinvestment and risk disclosure explained about 21.8% of firm value and that 78.2% might be explained by other factors. The aggregated the delta of firm value was influenced by delta firm size, liquidity, profitability, negative leverage and earnings reinvestment, and risk disclosure. Finally, H7 and H13 were accepted, meanwhile H8, H9, H10, H11 and H12 were rejected for unlisted banks. Model 2 was fit for examining the association between the delta of firm characteristics and the delta of risk disclosure with the delta of firm value in the listed banks.

The delta of firm size, liquidity, profitability, leverage and earnings reinvestment and the delta of risk disclosure determined the delta of firm value. Aggregated, the delta of firm characteristics and the delta of risk disclosure did not influence the delta of firm value. Thereby, H8, H9, H10, H12 and H13 were rejected, and only H7 could be accepted for Islamic banks. Model 2 was fit for examining the association between the delta of firm characteristics and the delta of risk disclosure and the delta of firm value in the Islamic banks.

In non-Islamic banks, only the delta of ROE had a significant positive effect on the delta of firm value, while other variables did not affect the delta of firm value. The delta of firm characteristics and the delta of risk disclosure, when they were aggregated as the independent variables, did affect the delta of firm value. The delta of firm value was determined by the delta of firm characteristics and risk disclosure. Model 2 was fit for examining the association between the delta of firm characteristics and the delta of risk

disclosure and the delta of firm value. The H9 was accepted, but H7, H8, H10, H11 and H12 were rejected.

The risk disclosure in annual reports for all banks, listed banks, unlisted banks, Islamic banks, and non-Islamic banks' annual reports did not have a relationship with firm value. These results indicate that risk disclosure was not value relevant for users and was notable for boosting firm value. This means that Indonesian banks were not able to convey information in terms of the signals related to risk through their annual reports and financial statements, and those risk reports were not useful for stakeholders. Therefore, H14 was rejected for all banks, listed banks, unlisted banks, Islamic banks, and non-Islamic banks.

Companies must maintain good communication with stakeholders by revealing their performance honestly and transparently. The risk disclosure in the annual reports is not value relevant, the risk information in annual reports might not be clearly described hence it is not fruitful for stakeholders and it may not be accepted by users and this does not increase firm value. Noise could interrupt the communication between banks and stakeholders such as the manager considering the costs of making reports and being afraid to expose their strategies (Elliott & Jacobson, 1994) or moral hazard (Arrow, 1971); hence, stakeholders receive incomplete information that does not meet what they need.

The risk disclosure of annual reports in Indonesian banking sector was not value relevant for stakeholders, and there is no relationship between risk disclosure and firm value. This is not in line with agency theory and signalling theories which mention that firm disclosure is value relevant (Anandarajan et al., 2011; Uyar & Kilic, 2012; Moumen, Othman &

Hussainey, 2013). This result contradicts with Al-Akra and Ali (2012) who argued that voluntary disclosure has a positive association with firm value, nevertheless in line with Hassan et al. (2009) who asserted that the association between voluntary disclosure and firm value is positive insignificant. It might happen because first, the exercise was over fitting and out of sample. Some annual reports could not be downloaded, blank, damaged, and were not available; hence they were excluded (31.2%). Second, the risk keyword from prior study which were employed in the UK, US, UEA, or Europe, and were translated into Indonesian risk keyword might not fit for examining risk disclosure in the annual report of the Indonesian banking sector. Third, the risk keyword which were employed in this study based on previous literatures (Kravet and Muslu, 2013); Elshandidy (2013) which is still need to be interpreted since the risk keyword were not attract investors. Fourth, the managers might have a different concept of the risk from investors. Managers send the signal by articulating risk keyword which are not really drawn the risk as what investors interested in, meanwhile formal risk is measured by the volatility of the firm's underlying assets. Fifth, due to considering the consequences of disclosure such as increase the cost and expose their strategies, hence managers might not actually act in the shareholders' interest by reporting their risk performance in more detail.

7.2 Theoretical Implications

The results suggest some theoretical implications. First, to measure the extent of risk disclosure, this research utilised a new list of Indonesian risk keywords, which is significantly different from the methods that were used in previous research, particularly in Indonesia. When the new method was employed in the banking industry, the results

indicated that the extent of risk disclosure in the Indonesia banking sector for all banks, listed, unlisted, Islamic and non-Islamic banks demonstrated an upward trend. Employing this new method in different companies or industries could reveal different results and provide a different interpretation of agency and signalling theories, which will hopefully enrich disclosure literature.

Second, it is surprising that the extent of risk disclosure was not affected by firm characteristics, namely: firm size (total assets), liquidity (LDR), profitability (ROE), leverage (debts/total assets), and earnings reinvestment ((EPS-DPS)/EPS). In other words, Model 1 was not a fit model for predicting the factors which affect a bank's decision to disclose risk. The results therefore were not able to support the results of previous research and contradict agency and signalling theories. The results of this study show that there are other opportunities to expand the current models that can improve the interpretation of the correlation between firm characteristics and risk disclosure, and augment the disclosure literature.

Third, an aggregation of firm characteristics and risk disclosure significantly affected firm value. Hence, Model 2 was a fit model for predicting the effect of the delta of firm characteristics and the delta of risk disclosure on the delta of firm value. The results showed that there are other opportunities to expand the current models that can improve the interpretation of the correlation between firm characteristics, risk disclosure and firm value, particularly for Islamic and unlisted firms.

Fourth, this is the first study that has employed earnings reinvestment as a variable for predicting the factors that affect a bank's decision to disclose risk. Even though the

results showed an insignificant correlation between risk disclosure and firm value, the results could add to knowledge about dividend theory, in particular Miller and Modigliani (1961) and the Clientele Effect theories. It also enriches capital market theory because the formula of earnings reinvestment employs EPS and DPS, which are related to share prices and dividends in either listed or unlisted banks, and this has not been explored by previous research.

Fifth, the major implication for theory from this research is the need to utilise a new method (the Black Scholes Merton model) for measuring the firm value of unlisted banks. The application of this method requires some assumptions to be made, and requires data related to market capitalisation and the share price of listed banks. The application of this method has the potential to enrich capital market theory and valuation option pricing theory.

Sixth, the annual reports produced by banks in Indonesia were not found to be value relevant for stakeholders. Banks did not communicate well with their stakeholders because they were not able to convey signals and risk information in accordance with the stakeholders' needs. These results have theoretical implications for enhancing signalling theory, stakeholder theory and communication theory.

7.3 Practical Implications

This research suggests some practical implications as follows:

First, this is the first study in which Indonesian risk keywords have been used to explore the extent of risk disclosure in the Indonesia banking sector. This method represents the development of a new measurement of risk disclosure.

Second, the total number of sentences in the annual reports varied and there was a large gap between the highest and the lowest. Moreover, the annual reports were not value relevant for stakeholders. For these reasons, the regulators and banks' managers should pay more attention to increasing the usefulness of disclosure for stakeholders, the completeness of their risk information, and on how to deliver signals and information more understandably and readably for stakeholders.

Third, this is the first study that has revealed a new method for measuring firm value in unlisted banks by employing the Black Scholes Merton model. This new method represents a significant practical implication for financial management knowledge, and valuation option pricing. The method also makes unlisted banks potentially more attractive to investors.

Fourth, earnings reinvestment is a new variable that has been employed for the first time in this study to test its relationship with risk disclosure and firm value, and the factors that affect a bank's decision to disclose risk. Even though the results showed that earnings reinvestment did not significantly affect risk disclosure and firm value, but it should be considered by managers and shareholders in valuing the firm when the company decides to reinvest earnings.

Fifth, for regulators this study provides some insights related to risk disclosure. Up until now, regulators have not yet monitored the depth of disclosure in terms of banks' performance. It is better to ensure that banks have disclosed their performance in their annual reports, since the results indicate that risk disclosure in the annual reports was also not affected by firm characteristics.

Sixth, risk disclosure in the Indonesia banking sector varied but the trend tended to be towards greater transparency. It is recommended that regulators enhance the regulations in order to push banks voluntarily and transparently to reveal their performance. Moreover, the regulators also need to consider the disclosure levels within the annual reports for other industries with regard to the levels of disclosure that are needed by stakeholders.

The results suggest that banks varied in the extent to which they reported their performance. Some banks used many sentences while some banks reported their performance in just a few sentences. This indicates that banks had a different style in expressing their performance in their annual reports. Stakeholders really need to understand this point and read annual reports critically, filtering the useful information from the whole information in an annual report in order to minimise risk before making financial decisions.

7.4 Limitations

Because Indonesian risk keywords, earnings reinvestment and measurement of firm value for unlisted banks were used for the first time by the researcher, this research has some limitations, as follow:

First, in translating the risk keywords into Indonesian, some risk keywords have similar meanings or the same meanings, for example: “significant” can be translated as “signifikan” or “penting” or “berarti” or “bermakna”; while “can” has some meanings similar to “bisa” or “dapat” or “mampu”. Even though those keywords have been tested by

validity and reliability in this study, it would be better if they were retested by a different validity and reliability test if they will be used for other sectors.

Second, because no researcher has used earnings reinvestment before, there are very limited sources and literature about it; hence, this research has limitations in terms of the explanations related to the association between earnings reinvestment and other variables.

Third, there is very little research that has developed a measurement for calculating firm value for unlisted banks before this study. This study utilised Black Scholes Merton models for approaching firm value measurement with long methods and some assumptions. First, risk free risk (r) is calculated using a proxy of JIBOR (Jakarta Interbank Offer Rate). Second, there is a case for using the volatility of listed banks' assets for calculating the estimated asset volatility for unlisted banks, whereby the listed banks should be grouped related to core capital, namely: Commercial Bank Business Group (Bank Umum Kelompok Usaha =BUKU), as mentioned in the Bank of Indonesia regulation number 14/26/PBI/2012. Third, for measuring the time to exercise (days), this model employs an estimate of the average term to maturity of a bank's liabilities, which requires judgment in deciding the maturity of liabilities. Some assumptions were adapted in this method, which means there is a possibility that the result is far from the real condition. Therefore, this method could be tested in future research that will be suggested in the next part of this chapter.

Fourth, in the analysis of the differences between Islamic banks and non-Islamic banks, there was a wide gap between these the size of these two populations. There were only

eleven Islamic banks, which must be compared with 109 non-Islamic banks, and the total data set of the Islamic banks was only 27 pieces of data; this could make for a weak statistical result.

7.5 Suggestions for Future Research

This study demonstrated a new measurement of firm value for unlisted banks; no previous researcher has calculated this measurement and this is the first study that has applied this method; hence, in future research there is a good opportunity to employ this method for other unlisted firms.

This research tested the relationship between risk disclosure, firm value and earnings reinvestment, which no researcher has tested before. As a result, this topic offers a real opportunity for future researchers to explore more about risk disclosure, earnings reinvestment, and firm value in other industries.

For measuring risk disclosure, this study employed QSRN6 to count keywords in sentences in annual reports, published in an Indonesian language version. Because this is the first research using these keywords, in the future scholars could employ them for other firms' annual reports, or even find other new risk keywords.

In order to ensure that risk disclosure in the annual reports has value relevance for users, future researchers should try to collect data through interviews with stakeholders such as investors, shareholders, financial analysts, depositors, debtors, regulators, and bank supervisors.

The study found no association between risk disclosure and firm characteristics, as indicated by the fact that the adjusted R square was very small for Model 1 in each group. This condition could be driven by other factors which are not tested in this study such as: national regulations (Dobler (2008); Elshandidy et al. (2011); mandated requirements (Bamber and McMeeking, 2010); stock market regulations (Rajab and Handley-Schachler (2009); corporate governance (Black, Jang, and Kim, 2006); Kara Brah Mo Lu (2013). These regulations could push companies to disclosure more of their firm's performance. This result offers a potentially fruitful area for future researchers to examine the effect of regulations on risk disclosure.

This study employs LDR for a proxy liquidity ratio as the independent variable, for the next research it is suggested to employ "Giro Wajib Minimum (GWM)" or reserve requirement (RR), which is a mandated requirement of the Bank of Indonesia. This ratio is mandated in order to ensure that banks have a reserve to cover short term debt withdrawals and also as part of the BI's role in prudential macro management.

All firms deal with risk; nevertheless, companies with sharia principles have a different set of risk, dependent on shariah law. Very few researchers have examined the relationship between risk disclosure and shariah law. It will be an important challenge for future researchers to measure risks for banks operating within Islamic law and use this as a variable on the relationship with disclosure.

For future research it is suggested that the study's questions be examined with more data and over more years for Islamic banks.

REFERENCES

- Abraham, S., & Cox, P. (2007). Analysing the determinants of narrative risk information in UK FTSE 100 annual reports. *The British Accounting Review*, 39(3), 227-248.
- Abraham, S., Marston, & Slack, T. (2014). Annual Report Business Risk Factor Statements: Views of UK Institutional Investors. School of Management and Languages, Heriot Watt University, Edinburgh, United Kingdom.
- Aburaya, R. (2012). *The Relationship Between Corporate Governance And Environmental Disclosure: UK Evidence*. Durham University.
- Acharya, V. V., Richardson, M., Philippon, T., & Roubini, N. (2009). *Restoring Financial Stability: How to repair a Failed System*. New Jersey: John Wiley & Sons.
- Admati, A. R., & Pfleiderer, P. (2000). Forcing firms to talk: financial disclosure regulation and externalities. *The Review of Financial Studies*, Vol. 13 No. 3, 479-519.
- Agostino, M., Drago, D., & Silipo, D. B. (2011). The value relevance of IFRS in the European banking industry. *Review of Quantitative Finance and Accounting*, 36(3), 437-457. doi: 10.1007/s11156-010-0170-710.2139/ssrn.314001
- Agyei-Mensah, B. K. (2012). Association between firm-specific characteristics and levels of disclosure of financial information of rural banks in the Ashanti region of Ghana *Journal of Applied Finance & Banking*, vol.2, no.1, 69-92.
- Akerlof, G. A. (1970). The market for "lemons": Quality uncertainty and the market mechanism. *The quarterly journal of economics*, 488-500.
- Akhtaruddin, M., Hossain, M. A., Hossain, M., & Yao, L. (2009). Corporate governance and voluntary disclosure in corporate annual reports of Malaysian listed firms. *Journal of Applied Management Accounting Research*, 7(1), 1-19.
- Al-Akra, M., & Ali, M. J. (2012). The value relevance of corporate voluntary disclosure in the Middle-East: The case of Jordan. *Journal of Accounting and Public Policy*, 31(5), 533-549. doi: <http://dx.doi.org/10.1016/j.jaccpubpol.2011.10.007>
- Al-Baluchi, A. E. A. (2006). *The Impact of AAOIFI Standards and Other Bank Characteristics on the Level of Voluntary Disclosure in the Annual Reports of Islamic Banks* (PhD), University of Surrey.
- Al-Janadi, Y., Rahman, R. A., & Omar, N. H. (2012). The level of voluntary disclosure practices among public listed companies in Saudi Arabia and the UAE: Using a modified voluntary disclosure index. *International Journal of Disclosure and Governance*, 9(2), 181-201. doi: <http://dx.doi.org/10.1057/jdg.2011.19>
- Aljifri, K. (2008). Annual report disclosure in a developing country: The case of the UAE. *Advances in Accounting*, 24(1), 93-100. doi: <http://dx.doi.org/10.1016/j.adiac.2008.05.001>
- Aljifri, K., Alzarouni, A., Ng, C., & Tahir, M. I. (2014). The Association between Firm Characteristics and Corporate Financial Disclosures: Evidence from UAE Companies. *International Journal of Business & Finance Research (IJBFR)*, 8(3), 101-123.
- Aljifri, K., & Hussainey, K. (2007). The determinants of forward-looking information in annual reports of UAE companies. *Managerial Auditing Journal*, 22(9), 881-894.
- Amran, A., Bin, A. M. R., & Hassan, B. C. H. M. (2009). Risk Reporting: An Exploratory Study on Risk Management Disclosure in Malaysian Annual Report. *Managerial Auditing Journal*, Vol. 24, No. 1, 39-57.

- Anandarajan, A., Francis, B., Hasan, I., & John, K. (2011). Value relevance of banks: global evidence. *Review of Quantitative Finance and Accounting*, 36(1), 33-55.
- Andres, P. d., Azofra, V., & Lopez, F. (2005). Corporate Boards in OECD Countries: size, composition, functioning and effectiveness. *Corporate Governance: An International Review*, Volume 13 Number 2, 197-210.
- Antonio, M. S. i. (2001). *Bank syariah:dari teori ke praktek*. Jakarta: Gema Insani.
- Ariffin, N. M. (2005). *Enhancing Transparency and Risk Reporting in Islamic Banks*. (PhD), University of Surrey.
- Arrow, K. (1971). *Essays in the theory of risk-bearing*. Chicago: Markham.
- Aryani, D. N. (2015). *Determinants of Risk Reporting in Indonesian Listed Banks*. Paper presented at the Postgraduate Research Student Conference University of Gloucestershire, UK.
- Ascarya. (2006). *Akad dan Produk Bank Syariah: Konsep dan Praktek di Beberapa Negara*: Bank Indonesia.
- Asutay, M. (2008). *PhD-Research Support Workshop Programme: Research Methodology*. Lecture Paper, School of Government and International Affairs. Durham University. England.
- Babaei, Z., Shahveisi, F., & Jamshidinavid, B. (2013). Correlation between Financial Leverage and Firm Value in Companies Listed in the Tehran Stock Exchange: A Case Study *Research Journal of Finance and Accounting*, Vol.4 No.5.
- Bagnoli, M., & Watts, S. G. (2005). *Financial reporting and Voluntary disclosures*. . Purdue University.
- Bailey, W., Karolyi, G. A., & Salvac, C. (2005). The economic consequences of increased disclosure: evidence from international cross-listings. . *Journal of Financial Economics*,, 81(1), 175-213.
- Bakar, M. A. (2010). *Broad Distinction between Islamic and Conventional Banking*. Paper presented at the Seminar on Islamic Finance, Malaysia.
- Baker, H. K., & Powell, G. E. (2012). Dividend policy in Indonesia: survey evidence from executives. *Journal of Asia Business Studies*, 6(1), 79-92.
- Bamber, M., & McMeeking, K. (2010). An examination of voluntary financial instruments disclosures in excess of mandatory requirements by UK FTSE 100 non-financial firms. *Journal of Applied Accounting Research in Accounting Regulation*, Vol. 11 No. 2, pp. 133-153.
- Bamber, M., & McMeeking, K. (2012). The quantity and quality of reporting financial instruments under International Financial Reporting Standard 7 Financial Instruments: Disclosure.
- Bank, B. o. P. a. F. A. D. D. N. (2004). *Direct Investment - Reinvested Earnings (Vol. Issue paper 18): IMF Committee On Balance Of Payments Statistics Balance Of Payments Technical Expert Group, Bopteg*
- Barakat, A., Chernobai, A., & Wahrenburg, M. (2014). Information asymmetry around operational risk announcements. *Journal of Banking & Finance*, 48, 152–179.
- Barako, D. G., Hancock, P., & Izan, H. (2007). Determinants of voluntary disclosures in Kenyan companies annual reports. *African Journal of Business Management*, 1(5), 113-128.
- Barth, M. E., Beaver, W. H., & Landsman, W. R. (2001). *The Relevance of the Value Relevance Literature For Financial Accounting Standard Setting: Another View*. Rochester, Rochester.

- Baydoun, N., & Willetts, R. (2000). Islamic Corporate Report. *Abacus*, 36/1, 1.
- BCBS. (1998). Enhancing Bank Transparency Public: disclosure and supervisory information that promote safety and soundness in banking systems. . Basle.
- Beck, T., Demirgüç-Kunt, A., & Merrouche, O. (2010). Islamic vs. Conventional Banking Business Model, Efficiency and Stability (Vol. 5446): The World Bank Development Research Group Finance and Private Sector Development Team.
- Beisland, L. A. (2009). A Review of the Value Relevance Literature. *The Open Business Journal*, 2, 7-27.
- Beretta, S., & Bozzolan, S. (2004). A framework for the analysis of firm risk communication. *The International Journal of Accounting*, 39(3), 265-288.
- Berle, A. A., & Means, G. C. (1932). *The Modern Corporation & Private Property* Retrieved from <http://www.unz.org/Pub/BerleAdolf-1932-00010?View=PDF>
- Bessis, R. M. i. B. W., Chichester. (2002). *Risk Management in Banking*. Chichester: Wiley.
- Bhasin, M. (2012). 'Voluntary' Corporate Governance Disclosures Made in the Annual Reports: An Empirical Study. *International Journal of Management and Innovation*, 4(1), 46-67.
- BIS. (2003). Consultative Document The New Basel Capital Accord.
- BIS. (2006). Enhancing corporate governance for banking organisations. Switzerland.
- BIS. (2010). Principles for enhancing corporate governance Switzerland.
- Black, B., Jang, H., & Kim, W. (2006). Does Corporate Governance Predict Firms' Market Values? Evidence from Korea. *Journal of Law, Economics & Organization*, 22, 366-413.
- Black, F. (1976). The pricing of commodity contracts. *Journal of Financial Economics*, 3(1), 167-179.
- Bodie, Z., Kane, A., & Markus, A. J. (2011). *Investment* (9 ed.). New York: McGraw-Hill.
- Bokpin, G. A. (2013). Determinants and value relevance of corporate disclosure : Evidence from the emerging capital market of Ghana. *Journal of Applied Accounting Research in Accounting Regulation*, Vol. 14 No. 2.
- Botosan, C. (1997). Disclosure level and cost of capital. *Accounting Review*, 72 (3).
- Brooks, R., & Yan, D. Y. (1999). London Inter-Bank Offer Rate (LIBOR) versus Treasury Rate. *The Journal of Fixed Income*, Vol. 9, No. 1, 71-83.
- Brounen, D., Hans Op 't, V., & Raitio, V. (2007). Transparency in the European Non-listed Real Estate Funds Market. *Journal of Real Estate Portfolio Management*, 13(2), 107-117.
- Buser, S. A., & Hess, P. J. (1986). Empirical determinants of the relative yields on taxable and tax-exempt securities. *Journal of Financial Economics*, 17(2), 335-355.
- Capasso, A., Rossi, M., & Simonetti, B. (2005). Ownership Structure Heterogeneity and Performance: A Comparison between Listed and Unlisted Companies.
- Cartwright, P. (2006). Risks and returns of prior approval by licensing: The case of banking. *Journal of Banking Regulation*, 7(3/4), 298-309.
- Caruana, J. (2011). *Financial stability and risk disclosure* Paper presented at the FSB Roundtable on risk disclosure, Basel.
- Cerf, A. R. (1961). *Corporate reporting and investment decisions: Public Accounting Research Program*, Institute of Business and Economic Research, University of California.

- Chakroun, R., & Hussainey, K. (2013). *Disclosure Quality in Tunisian Annual Reports*. . Paper presented at the Paper presented at the Critical Studies in Accounting, Economics and Finance (CSAF) Conference, Abu Dhabi, UAE.
- Chen, C. X., Lu, H., & Sougiannis, T. (2012). The Agency Problem, Corporate Governance, and the Asymmetrical Behavior of Selling, General, and Administrative Costs*. *Contemporary Accounting Research*, Vol. 29 No. 1, 252-282. doi: 10.1111/j.1911-3846.2011.01094.x
- Chong, B. S., & Liu, M.-H. (2009). Islamic banking: Interest-free or interest-based? *Pacific-Basin Finance Journal*, 17(1), 125-144.
- Chung, K. H., & Pruitt, S. W. (1994). A simple approximation of Tobin's q. *Financial Management*, 23(3), 70-70.
- Churchill, G. A. (2010). *Basic Marketing Research* (7th ed.): South-Western Publishing Co.
- Collins, D. a. K., S.P (1989). An Analysis of the Intertemporal and Cross-Sectional Determinants of the Earnings Response Coefficients. *Journal of Accounting and Economics*, 11, 143-181.
- Connelly, B. L., Certo, S. T., Ireland, R. D., & Reutzel, C. R. (2011). Signaling Theory: A Review and Assessment. *Journal of Management*, 37(1), 39-67.
- Craswell, A. T., & Taylor, S. L. (1992). Discretionary Disclosure Of Reserves By Oil And Gas Companies: An Economic Analysis. *Journal of Business Finance & Accounting*, 19(2), 295-308. doi: 10.1111/j.1468-5957.1992.tb00626.x
- Creswell, J. W. (2014). *Research design: Qualitative, Quantitative, and Mixed Methods Approach* (4 ed.). London, UK: SAGE Publications, Inc.
- Crotty, M. (1998). *The Foundations of Social Research* London: Sage
- Darrough, M. N. (1993). Disclosure policy and competition: Cournot vs. Bertrand. *The Accounting Review*, 68(3), 534.
- Demirguc-Kunt, & Maksimovic, V. (1999). Institutions, Financial Markets And Firm Debt Maturity. *Journal of Financial Economics*, 54, 295-336.
- Deumes, R. (2008). A Content Analysis of Narrative Risk. *Journal of Business Communication*, Volume 45, Number 2, 120-157.
- Diamond, D., & Verrecchia, R. (1991). Disclosure, Liquidity, and the Cost of Capital. *The Journal of Finance*, 46 (4), 1325-1359.
- Dobler, M. (2008). Incentives for risk reporting - A discretionary disclosure and cheap talk approach. *The International Journal of Accounting*, 43(2), 184.
- Dobler, M., Lajili, K., & Zéghal, D. (2011). Attributes of Corporate Risk Disclosure: An International Investigation in the Manufacturing Sector. *Journal of International Accounting Research*, 10(2), 1-22.
- Dragomir, & Cristina, M. (2009). Corporate Governance in the European Union: The Implications for Financial and Narrative Reporting,. *International Journal of Business and Economics*, Vol. 9, No. 1, 53-64.
- Dye, R. A. (1985). Strategic accounting choice and the effects of alternative financial reporting requirements. *Journal of Accounting Research*, 23(2), 544-574.
- Eccles, R., Herz, R., Keegan, E. and Phillips, D. (2001). *The Value Reporting Revolution: Moving Beyond the Earnings Game*, . New York, NY: John Wiley & Sons.
- Eisenhardt, K. M. (1989). Agency theory: An assessment and review. *Academy of management review*, 14(1), 57-74.

- El-Gamal, M. A. (2000). *A Basic Guide to Contemporary Islamic Banking and Finance* Retrieved from <http://www.lariba.com/dev/knowledge-center/islamic-banking-guide.pdf>
- Elliott, R. K., & Jacobson, P. D. (1994). Costs and benefits of business information disclosure. *Accounting Horizons*, 8(4), 80.
- Elshandidy, T., Fraser, I., & Hussainey, K. (2011). Aggregated, voluntary, and mandatory risk disclosure incentives: evidence from UK FTSE all share. *working paper*(Stirling University).
- Elshandidy, T., Fraser, I., & Hussainey, K. (2013). Aggregated, voluntary, and mandatory risk disclosure incentives: Evidence from UK FTSE all-share companies. *International Review of Financial Analysis*, 30(0), 320-333.
- Elzahar, H., & Hussainey, K. (2012). Determinants of narrative risk disclosures in UK interim reports. *The Journal of Risk Finance*, 13(2), 133-147.
- Espinosa, M., Tapia, M., & Trombetta, M. (2005). Disclosure and liquidity. *Nº.: UC3M Working Papers. Business Economics 2005-02.*
- Estrada, F. (2011). Thomas S. Schelling: Game theory and indirect communication *Facultad de Finanzas: MPRA (Munich Personal RePEc Archive)* (Vol. MPRA Paper No. 34988, posted 25): Universidad Externado de Colombia.
- Evans, J. P., & Gentry, J. A. (2003). Using Tobin's Q Ratio to Assess the Strategy of Repurchasing Shares. *Finance India*, XVII(1), 149-163.
- Fama, E. F. (1980). Agency Problems and the Theory of the Firm. *The Journal of Political Economy*, 88(2), 288-307.
- Fama, E. F., & Jensen, M. C. (1983). Separation of ownership and control. *Journal of Law and Economics*, 26(2), 301-325.
- Fathi, J. (2013). Corporate Governance and the Level of Financial Disclosure by Tunisian Firm.
- Faure, A. (2013). *Banking: an introduction* (1st ed.): Quoin Institute (Pty) Limited & bookboon.com.
- Fiechter, P., & Zhou, J. (2013). *The Impact of the Greek Sovereign Debt Crisis on European Banks' Disclosure and its Economic Consequen.* Paper presented at the Illinois International Journal of Accounting Symposium, China.
- Filip, A., & Raffournier, B. (2010). The value relevance of earnings in a transition economy: The case of Romania. *The International Journal of Accounting*, 45(1), 77-103.
- Francis, J., LaFond, R., Olsson, P. M., & Schipper, K. (2004). Costs of Equity and Earnings Attributes. *The Accounting Review*, Vol. 79. No. 4, 967-1010.
- Freeman, E. (2010). *Strategic Management: A Stakeholder Approach* Retrieved from http://books.google.co.uk/books?hl=en&lr=&id=NpmA_qEiOpkC&oi=fnd&pg=PR5&ots=6-cnH1L5TK&sig=5b1qisnHbD4eSlg_PPwSjXokGyl#v=onepage&q&f=false
- Freeman, R. E. (2004). The Stakeholder Approach Revisited *zfwu*, 5 (3), 228-241
- Frolov, M. (2007). Why do We Need Mandated Rules of Public Disclosure for Banks ? . *Journal of Banking Regulation*, 8.2, 177-191.
- Ghuri, P., & Gronhaug, K. (2005). *Research Methods in Business Studies: A Practical Guide* (3rd ed.): Prentice Hall.
- Gordon, L. A., Loeb, M. P., & Sohail, T. (2010). Market Value Of Voluntary Disclosures Concerning Information Security. *MIS Quarterly*, 34(3), 567.

- Gow-Liang, H., Hsiu-Chen, C., & Chang-Hsi, Y. (2006). A Comprehensive Study on Information Asymmetry Phenomenon of Agency Relationship in the Banking Industry. *Journal of American Academy of Business, Cambridge*, 8(2), 91-97. doi: 10.2307/1879431. JSTOR1879431.
- Gray, P. S. e. a. (2007). *The Research Imagination: An Introduction to Qualitative and Quantitative Methods*. Cambridge: Cambridge University Press.
- Gray, R., Owen, D., & Adams, C. (1996). *Accounting and Accountability: Changes And Challenges In Corporate and Social Reporting*. London: Prentice-Hall.Europe.
- Greco, G. (2011). The management's reaction to new mandatory risk disclosure: A longitudinal study on Italian listed companies. *Corporate Communications: An International Journal*, Vol. 17 No. 2, 2012, pp. 113-137.
- Gruning, M. (2011). Artificial intelligence measurement of disclosure (AIMD). *European Accounting Review*, 20(3), 485-519.
- Guilford, J. P., & Fruchte, B. (1978). *Fundamental Statistics in Psychology and Education* (6 th ed.). New York: McGraw Hill.
- Gujarati, D. N., & Porter, D. C. (2009). *Basic Econometrics* (5th ed.). Singapore: McGraw-Hill.
- Hameeda Abu, H., & Al-Ajmi, J. (2012). Risk management practices of conventional and Islamic banks in Bahrain. *The Journal of Risk Finance*, 13(3), 215-239.
- Haniffa, R. M., & Cooke, T. E. (2005). The impact of culture and governance on corporate social reporting. *Journal of Accounting and Public Policy*, 24(5), 391-430.
- Hasan, Z. (2011). Money creation and control from Islamic perspective *Munich Personal RePEc Archive (MPRA) Paper No. 28366*. NCEIF The Global University of Islamic Finance.
- Hassan, Romilly, P., Giorgioni, G., & Power, D. (2009). The value relevance of disclosure: Evidence from the emerging capital market of Egypt. *The International Journal of Accounting*, 44(1), 79.
- Hassan, A. (n.d.). *The Global Financial Crisis and Islamic Banking*. Islamic Economics Unit, The Islamic Foundation, UK.
- Hassan, M. K. (2009b). UAE corporations-specific characteristics and level of risk disclosure. *Managerial Auditing Journal*, 24(7), 668-687.
- Hassan, M. K., & K.Lewis, M. (2007). *Handbook of Islamic Banking* Retrieved from <http://www.kantakji.com/media/2129/b029.pdf>
- Hassan, O., & Marston, C. (2010). Disclosure Measurement in the Empirical Accounting Literature: A Review Article *Economics and Finance Working Paper Series Working Paper No. 10-18* from <http://www.brunel.ac.uk/about/acad/sss/depts/economics>
- Hasseldine, J., Salama, A. and Tom, J.S. (2005). Quantity versus quality: the impact of environmental disclosures on the reputations of UK Plcs,.. *The British Accounting Review*, 37/2, 231-248.
- Healy, P. M., & Palepu, K. (2009). *Information Asymmetry, Corporate Disclosure and the Capital Markets: A Review of the Empirical Disclosure Literature*. Rochester, Rochester.
- Healy, P. M., & Palepu, K. G. (2001). Information asymmetry, corporate disclosure, and the capital markets: A review of the empirical disclosure literature. *Journal of Accounting and Economics*, 31(1-3), 405-440. doi: [http://dx.doi.org/10.1016/S0165-4101\(01\)00018-0](http://dx.doi.org/10.1016/S0165-4101(01)00018-0)

- Heffernan, S. (2005). *Modern Banking*. Chichester, England: John Wiley & Sons, Ltd.
- Helfer, E. A. (2001). *Financial Analysis :Tools and Techniques*. United State of America: McGraw-Hill.
- Holm, C., & Laursen, P. B. (2007). Risk and Control Developments in Corporate Governance: changing the role of the external auditor? *Corporate Governance: An International Review*, 15(2), 322-333.
- Hopskins, P. E. (1996a). The effect of financial statement classification of hybrid financial instruments on financial analysts' stock price judgments. *Journal of Accounting Research*, 34, 33-50.
- Hopskins, P. E. (1996b). The effect of financial statement classification of hybrid financial instruments on financial analysts' stock price judgments. . *Journal of Accounting Research*, 34, 33-50.
- Höring, D., & Gründl, H. (2011). Investigating Risk Disclosure Practices in the European Insurance Industry. *Geneva Papers on Risk & Insurance*, 36(3), 380-413.
- Hull, J. C. (2009). *Option, Futures and Other Derivatives*
- Hussain, H. A., & Al-Ajmi, J. (2012). Risk management practices of conventional and Islamic banks in Bahrain. *The Journal of Risk Finance*, 13(3) 215-239.
- Hussainey, K., & Walker, M. (2009). The effects of voluntary disclosure and dividend propensity on prices leading earnings. *Accounting & Business Research (Wolters Kluwer UK)*, 39(1), 37-55.
- Hutajulu, S. (2002). *Ontent Analysis Of The Evolution Of Discretionary Disclosure At Texaco Inc.: An Agency Theory Perspective*. (PhD), Case Western Reserve University.
- IASB. (2010). International Financial Reporting Standard. London: International Accounting Standards Board
- Ibrahim, W. H., Ismail, A.G., Zabaria, W.N. (2011). Disclosure, Risk and Performance in Islamic Banking: A Panel Data Analysis. *International Research Journal of Finance and Economics(Issue 72)*, 102.
- ICAEW. (2011). Reporting Business Risks:Meeting Expectations (pp. iii). UK: Financial Reporting Faculty.
- Inchausti, B. (1997). The influence of company characteristics and accounting regulation on information disclosed by Spanish firms. *European Accounting Review*, Vol. 6 No. 1,, 45-68.
- Inchausti, B. G. (1997). The influence of company characteristics and accounting regulation on information disclosed by Spanish firms. *The European Accounting Review*, 6(1), 45-68.
- Ivers, M. (1991). *The random house guide to good writing*. New York: Random House.
- Jensen, M. C., & Meckling, W. H. (1976). Theory of the firm: Managerial behavior, agency costs and ownership structure. *Journal of Financial Economics*, 3(4), 305-360. doi: [http://dx.doi.org/10.1016/0304-405X\(76\)90026-X](http://dx.doi.org/10.1016/0304-405X(76)90026-X)
- Jung, J. (2000). Credits rationing with a moral hazard problem. *Seoul Journal of Economics*, 13(2), 165-183.
- Kaplan, S. N., & Stromberg, P. (2003). Financial Contracting Theory Meets the Real World: An Empirical Analysis of Venture Capital Contracts. *The Review of Economic Studies*, 70(2), 281-315.

- Kara Brah Mo Lu, Y. Z. (2013). Is Corporate Governance A Determinant of Auditor Choice?-Evidence From Turkey. *Kurumsal Yönetim Denetçi Seçiminde Belirleyici midir?-Türkiye'den Bulgular.*, 13(2), 273-284.
- Karın, S. (2013). The Impact of IFRS on the Value Relevance of Accounting Information: Evidence from Turkish Firms. *International Journal of Economics & Finance*, 5(4), 71-80. doi: 10.5539/ijef.v5n4p71
- Khan, A., Kaleem, A., & Nazir, M. S. (2012). Impact of Financial Leverage on Agency cost of Free Cash Flow: Evidence from the Manufacturing sector of Pakistan. *Journal of Basic and Applied Scientific Research*, 2, 7, 6694-6700.
- Khan, M. S., & Mirakhor, A. (1989). The Financial System and Monetary Policy in an Islamic Economy. *JKAU: Islamic Econ.*, Vol. 1, 39-57.
- Korotkikh, K. (n.d). *The Effect of Financial Leverage in Firm Value: Evidence from the Netherlands*. (Master), University of Twente, Netherland.
- Kouki, M., & Said, H. b. (2011). Does management ownership explain the effect of leverage on firm value? An analysis of French listed firms. *Journal of Business Studies Quarterly*, Vol. 3, No. 1, 169-186.
- Kravet, T., & Muslu, V. (2013). Textual Risk Disclosures and Investors' Risk Perceptions. *Review of Accounting Studies*, 18(4), 1088-1122. doi: DOI 10.1007/s11142-013-9228-9
- Kurniawan, D. M., & Indriantoro, N. (2000). *Corporate Governance in Indonesia*. Paper presented at the The Second Asian Roundtable on Corporate Governance, Hong Kong, China.
- Lajili, K., & Zeghal, D. (2005). A Content Analysis of Risk Management Disclosures in Canadian Annual Reports *Canadian Journal of Administrative Sciences*, 22(2), 125-142.
- Lasswell, H. D. (1948). The structure and function of communication in society. *The communication of ideas*, 37.
- Lee, T. (2006). *Financial Reporting and Corporate Governance*. England: John Wiley & Sons, Ltd.
- Leshem, S. (2012). A Signaling Theory of Lockups in Merger University of Southern California.
- Lewis, M. K. (2001). Islam and accounting. *Accounting Forum*, Vol 25 No 2.
- Linsley, & Shrives. (2006). A study of risk disclosures in the annual reports of UK. *The British Accounting Review*, 38, 387-404.
- Linsley, P., & Shrives, P. (2000). Risk management and reporting risk in the UK *Journal of Risk Research*, Vol.3 No.1, 115-129.
- Linsley, P. M., & Shrives, P. J. (2005). Transparency and the disclosure of risk information in the banking sector. *Journal of Financial Regulation and Compliance*, 13(3), 205-214.
- Lintner, J. (1956). Distribution of Incomes of Corporations Among Dividends, Retained Earnings and Taxes. *American Economic Review*, 46 (2), 97-113.
- Litzenberger, R. H., & Ramaswamy, K. (1979). The effect of personal taxes and dividends on capital asset prices: Theory and empirical evidence. *Journal of Financial Economics*, 7(2), 163-195.
- M.Wachowicz, J. C. V. H. J. (2005). *Fundamentals of Financial Management*. England: Prentice Hall.

- Marshall, A., & Weetman, P. (2007). Modelling Transparency in Disclosure: The Case of Foreign Exchange Risk Management. *Journal of Business Finance & Accounting*, 34(5/6), 705.
- Mathuva, D. (2012). The Determinants of Forward-looking Disclosures in Interim Reports for Non-financial Firms: Evidence from a Developing Country. *International Journal of Accounting and Financial Reporting*, Vol. 2, No. 2, 125-141.
- McAfee, R. P., & McMillan, J. (1987). Competition for agency contracts. *The Rand Journal of Economics*, 296-307.
- McGilvery, A., Faff, R., & Pathan, S. (2012). Competitive valuation effects of Australian IPOs. *International Review of Financial Analysis*, 24(0), 74-83.
- McKinnon, J. L., & Dalimunthe, L. . (1993). Voluntary disclosure of segment information by Australian diversified companies. *Accounting & Finance*, 33(1), 33-50.
- McLeay, M., Radia, A., & Thomas, R. (2014). Money creation in the modern economy, *Quarterly Bulletin-Q1*.
- Mercer, M. (2004). How do investors assess the credibility of management disclosure? *Accounting Horizons*, 18 (3), 185-196.
- Merton, R. C. (1973). Theory of rational option pricing. *The Bell Journal of Economics and Management Science*, 141-183.
- Miihkinen, A. (2012). What Drives Quality of Firm Risk Disclosure?The Impact of a National Disclosure Standard and. *The International Journal of Accounting*, 6.
- Miller, M. H., & Modigliani, F. (1961). Dividend policy, growth, and the valuation of shares. *the Journal of Business*, 34(4), 411-433.
- Milne, M. J., & Adler, R. W. (1999). Exploring the reliability of social and environmental disclosures. *Accounting, Auditing & Accountability Journal*, Vol. 12 No. 2, 237-256.
- Mirza, A. A., Orrell, M., & Holt, G. J. (2008). *IFRS Practical Implementation Guide and Workbook* (Vol. 2nd ed). Canada: John Wiley & Sons, Inc.
- Mohobbot, A. M. (2005). Corporate Risk Reporting Practices in Annual Reports of Japanese Companies. *Japanese Journal of Accounting*, 16(1), 113-133.
- Morgan, A. (2008). A measure of the precision of forward-looking MD&A statements. United States.: Nova Southeastern University.
- Morris, R. D. (1987). Signalling, Agency Theory And Accounting Policy Choice. *Accounting and Business Research*, 18(69), 47-47.
- Moumen, N., Othman, H. B., & Hussainey, K. (2013). The Value Relevance of Risk Disclosure in Annual Reports: Evidence from MENA Emerging Markets.
- Muzahem, A. (2011). *An empirical analysis on the practice and determinants of risk disclosure in an emerging capital market: the case of United Arab Emirates*. (Doctor), University of Portsmouth, Portsmouth.
- Myers, S. C., & Majluf, N. S. (1984). Corporate financing and investment decisions when firms have information that investors do not have. *Journal of Financial Economics*, 13(2), 187-221. doi: [http://dx.doi.org/10.1016/0304-405X\(84\)90023-0](http://dx.doi.org/10.1016/0304-405X(84)90023-0)
- Naser, K., Al-Khatib, K., & Karbhari, Y. (2002). Empirical evidence on the depth of corporate information disclosure in developing countries: The case of Jordan. *International Journal of Commerce & Management*, 12(3/4), 122-155.
- Neter, J., Michael H. Kutner, Christo. (1996). *Applied Linear Statistical Models*. Boston: McGraw Hill.

- Ntim, C. G., Lindop, S., & Thomas, D. A. (2011). Corporate Governance and Risk Reporting in South Africa: A Study of Corporate Risk Disclosures in the Pre- and Post-2007/2008 Global Financial Crisis Period. School of Management and Business Aberystwyth University, Aberystwyth, UK.
- Okcabol, F. a. T., T. (1993). Dismantling Financial Disclosure Regulations: Testing The Stigler-Benston Hypothesis. *Accounting, Auditing and Accountability Journal*, 6(1), 10-36.
- Oliveira, J., Rodrigues, L. L., & Craig, R. (2011). Risk-related disclosure practices in the annual reports of Portuguese credit institutions: An exploratory study. *Journal of Banking Regulation*, 12(2), 100-118.
- Oxelheim, L. (2008). Macroeconomic Turbulence: Corporate Performance, Transparency and Economic Growth. *School of Business and the Faculty of Economics*(Tímarit um viðskipti og efnahagsmál, Special Issue), 59-70.
- Papa, V. T., & Peters, S. J. (2011). User Perspectives on Financial Instrument Risk Disclosures under IFRS (Vol. 1): CFA Institute.
- Parlalis, S. K. (2011). Management of organisational changes in a case of de-institutionalisation. *Journal of Health Organization and Management*, 25(4), 355-384.
- Penno, M. C. (1997). Information quality and voluntary disclosure. *Accounting Review*, 275-284.
- Peraturan Bank Indonesia No. 9/15/PBI/2007 tentang Penerapan Manajemen Resiko dalam Penggunaa Teknologi Informasi oleh Bank Umum.
- Peraturan Bank Indonesia No: 5/8/PBI/2003 tentang Penerapan Manajemen Resiko Bagi Bank Umum.
- Peraturan Bank Indonesia No: 11/ 25 /PBI/2009 tentang Perubahan Atas Peraturan Bank Indonesia no. 5/8/PBI/2003 tentang Penerapan Manajemen Resiko Bagi Bank Umum.
- Popova, T., Georgakopoulos, G., Sotiropoulos, I., & Vasileiou, K. Z. (2013). Mandatory Disclosure and Its Impact on the Company Value. *International Business Research*, Vol. 6, No. 5.
- Poshakwale , S., & Courtis , J. K. (2005). Disclosure Level and Cost of Equity Capital : Evidence From Banking Industry. *Managerial and Decision Economic*, 26, 341-444.
- Post, J. E., Preston, L. E., & Sachs, S. (2002). Managing the extended enterprise: the new stakeholder view. *California management review*, 45(1), 6-28.
- PricewaterhouseCoopers. (2008). Accounting for change: transparency in the midst of turmoil: A survey of banks' 2007 annual reports.
- PricewaterhouseCoopers, S. (2000). Corporate Governance 1999 Survey of Institutional Investors: PricewaterhouseCoopers Singapore.
- Rajab, B., & Handley-Schachler, M. (2009). Corporate risk disclosure by UK firms: trends and determinants. *World Review of Entrepreneurship, Management and Sustainable Development*, 5(3), 224-243. doi: 10.1504/WREMSD.2009.026801
- Repullo, R., & Suarez, J. (2000). Entrepreneurial moral hazard and bank monitoring: a model of the credit channel. *European Economic Review*, 44(10), 1931-1950.
- Rock, A. J. (2007). Is the Logic of the t-test for Two Independent Samples Fallacious? An Analysis of the Ontological Status of the Treated Population. *North American Journal of Psychology*, 9(1), 163-172.

- Roden, F., & Stripling, T. (1997). Dividend reinvestment plans as efficient methods of raising equity financing. *Review of Financial Economics*, 5(1), 91-100.
- Ross, S., Westerfield, R., & Jordan, B. (2008). *Fundamentals of Corporate Finance* (8th ed.). New York: McGraw-Hill.
- Ross, S. A. (1979). Disclosure Regulation In Financial Markets: Implications Of Modern Finance Theory And Signaling Theory *Issues In Financial Regulation: Regulation of American Business and Industry Pinpoint* (pp. 177-202.).
- Ryan, B. (2007). *Corporate Finance and Valuation*. London: Thomson Learning.
- Ryan, B., Scapen, R., & Theobald, M. (2002). *Research Method and Methodology in Finance and Accounting* (2nd ed.). London: Thomson.
- Sachs, S., Ruhli, E., & Kern, I. (2009). *Sustainable Success with Stakeholders: The Untapped Potential*. London: Palgrave Macmillan.
- Samad, A., & Hassan, M. K. (1999). The Performance of Malaysian Islamic Bank during 1984-1997: An Exploratory Study. *International Journal of Islamic Financial Services*, 1(3).
- Schelling, T. S., & Estrada, F. (2011). Game theory and indirect communication (Vol. Paper No. 34988). Universidad Externado de Colombia, Facultad de Finanzas: MPRA (Munich Personal RePEc Archive).
- Schipper, K. (2003). Principles-based accounting standards. *Accounting Horizons*, 17(1), 61-72.
- Schoubben, F., & Rulle, C. V. (2004). The Determinants Of Leverage; Differences Between Quoted And Non Quoted Firms *Tijdschrift voor Economie en Management*, XLIX(4).
- Sensarma, R. a. J., M. (2009). "Are bank stocks sensitive to risk management?". *The Journal of Risk Finance*, Vol. 10 No. 1, 7-22.
- Shannon, C. E., & Weaver, W. (1948). A mathematical theory of communication: American Telephone and Telegraph Company.
- Sheu, Chung, H., & Liu, C. L. (2010). Comprehensive Disclosure of Compensation and Firm Value: The Case of Policy Reforms in Emerging Market *Journal of Business and Accounting*, 37 Nos 9-10, 1115-1144.
- Skinner, D. J. (1994). Why Firms Voluntarily Disclose Bad News. *Journal of Accounting Research*, 32(1), 38-60.
- Spence, M. (1973). Job Market Signaling. *Quarterly Journal of Economics*, 87(3), 355-374.
- Spence, M. (2002). Signaling in retrospect and the informational structure of markets. *The American Economic Review*, 92(3), 434-459.
- Suadiye, G. (2012). Value Relevance of Book Value & Earnings Under the Local GAAP and IFRS: Evidence from Turkey/Yerel Muhasebe Standartlarına ve UFRS'ye Göre Hazırlanan Kar ve Özkaynak Rakamlarının Hisse Senedi Fiyatlarına Yansımaları: Türkiye Örneği. *Ege Akademik Bakis*, 12(3), 301-310.
- Subramanian, S., & Reddy, V. N. (2012). Corporate governance disclosures and international competitiveness: A study of Indian firms. *Asian Business & Management*, 11(2), 195-218. doi: <http://dx.doi.org/10.1057/abm.2012.1>
- Suhardjanto, D., Dewi, A., Rahmawati, E., & Firazonia. (2012). Peran Corporate Governance dalam Praktik Risk Disclosure pada Perbankan Indonesia. *Jurnal Akuntansi & Auditing*, 9/No.1, 17-30.

- Sukuk, Fatwa Number 32 / DSN-MUI / IX / 2002 C.F.R. (National Shariah Board, Indonesian Council of Ulama. 2002).
- Surat Edaran No.SE-02/BL/2008 tentang Pedoman Penyajian dan Pengungkapan Laporan Keuangan Emiten atau Perusahaan Publik Industri Pertambangan Umum, Minyak dan Gas Bumi dan Perbankan.
- Teece, D. J. (1996). Firm organization, industrial structure, and technological innovation¹.
- Tencati, A., Perrini, F., & Pogutz, S. (2004). New Tools to Foster Corporate Socially Responsible Behavior. *Journal of Business Ethics*, 53(1-2), 173-190.
- Tobin, J. (1963). Commercial Banks as Creators of 'Money' In I. B. a. m. studies (Ed.), *Cowles foundation paper 205* (Vol. Homewood: In C. Carson (Ed.), pp. 408-419).
- Undang_undang Republik Indonesia No. 21 tahun 2008 tentang Perbankan Syariah (16 July 2008).
- Usmani, M. M. T. (1998). *An Introduction to Islamic Finance* Retrieved from <http://islamicfinancenews.files.wordpress.com/2009/09/an20introduction20to20islamic20finance.pdf>
- Uyar, A., & Kiliç, M. (2012). Value relevance of voluntary disclosure: evidence from Turkish firms. *Journal of Intellectual Capital*, 13(3), 363-376.
- Vitezic, N. (2011). Correlation between social responsibility and efficient performance in Croatian enterprises*. *Zbornik Radova Ekonomski Fakultet u Rijeka*, 29(2), 423-442.
- Wallace, R. S. O., & Naser, K. (1995). Firm-specific determinants of the comprehensiveness of mandatory disclosure in the corporate annual reports of firms listed on the stock exchange of Hong Kong. *Journal of Accounting and Public Policy*, 14(4), 311-368. doi: [http://dx.doi.org/10.1016/0278-4254\(95\)00042-9](http://dx.doi.org/10.1016/0278-4254(95)00042-9)
- Wallace, R. S. O., Naser, K., & Mora, A. (1994). The relationship between the comprehensiveness of corporate. *Accounting and Business Research*, 25(97), 41-41.
- Wang, Z., Ali, M. J., & Al-Akra, M. (2013). Value relevance of voluntary disclosure and the global financial crisis: evidence from China. *Managerial Auditing Journal*, 28 No. 5, 444-468.
- Ward, A. T. A. M. (2009). *Introduction to Financial Accounting* (sixth ed.). London: The Mc Grow-Hill.
- Watson, A., Shrivies, P., & Marston, C. (2002). Voluntary disclosure of accounting ratios in the UK. *The British Accounting Review*, 34(4), 289-313.
- Watts, R., & Zimmerman, J. L. (1983). Agency Problems, auditing and theory of the firm: some evidence. *Journal of Law and Economics*, 12(26), 613-633.
- Werner, R. A. (2014). How do banks create money, and why can other firms not do the same? An explanation for the coexistence of lending and deposit-taking. *International Review of Financial Analysis*, 36, 71-77.
- www.bi.go.id.
- www.idx.co.id.
- Yuen, D. C. Y., Liu, M., Zhang, X., & Lu, C. (2009). A Case Study of Voluntary Disclosure by Chinese Enterprises *Asian Journal of Finance & Accounting*, 1(2).
- Zdolsek, D., & Kolar, I. (2013b). Management disclosure practices for disaggregated (financial) information in Slovenian unlisted companies. *Journal for East European Management Studies*, 18(2), 264-289.

APPENDIX

APPENDIX A - PREVIOUS RESEARCH

Authors	Variables (D=dependent; I=independent)	Sample	Main findings
Aljifri et al. (2014)	<p>D=extent of disclosure</p> <p>I= type of industry, listing status, return on equity, liquidity, market capitalization, foreign ownership, non-executive directors, and audit committee</p>	113 United Arab Emirates firms, in 2005	<p>The listing status and industry type (banks) have a positive association with disclosure significantly, but size has a negative relationship.</p> <p>The foreign ownership, non executive directors and audit committee have a positive relationship insignificantly. The other variables have an insignificant correlation with disclosure.</p>
Popova et al. (2013)	<p>D= disclosure</p> <p>I = stock return, earning, leverage, size , age, listing status</p>	20 UK companies from the FTSE 350 Index for a period of five years, from 2006 to 2010.	<p>Company value, leverage, listing status, and age have a relationship with mandatory disclosure significantly.</p> <p>Earning, size and listing status do not have a correlation with mandatory disclosure</p>
Elzahar and Hussainey (2012)	<p>D=risk disclosure</p> <p>I= sector type, size, cross listing, profitability, liquidity, and gearing.</p>	72 non-financial companies in the UK published interim reports between 1 June 2009 and 31 May 2010.	Liquidity, leverage, profitability, cross listing, corporate governance have an insignificant influence to narrative risk disclosure

Authors	Variables (D=dependent; I=independent)	Sample	Main findings
Agyei-Mensah (2012)	D= disclosure I= firm size, leverage, profitability, audit firm size and liquidity	21 rural banks in the Ashanti region, Ghana in 2009	Profitability has a positively association with the disclosure level. Insignificant relationship between liquidity, firm size and audit firm size and the disclosure level.
Mathuva (2012)	D= forward disclosure I=leverage, profitability, liquidity, size, capital, Foreign ownership, cross listing	91 firms listed on the Nairobi Securities Exchange for the interim periods in 2009 -2011	Leverage, profitability, capital ownership, and cross listed have a positive relationship with disclosure significantly. Insignificant relationship between size, liquidity and sector type, and disclosure.
Uyar and Kiliç (2012)	D= Market capitalization; market value to book value of equity I=voluntary disclosure Control variables=size, profitability, leverage, growth	129 manufacturing companies listed in the Istanbul Stock Exchange (ISE) for the year 2010.	Voluntary disclosure is value-relevant and impacts firm value significantly. Voluntary disclosure level has a significant positive correlation with current market value and future market value. Firm size and profitability have significant positive association with firm value. Leverage and growth do not have relationship with firm value. A high correlation between firm size and net income

Authors	Variables (D=dependent; I=independent)	Sample	Main findings
Al-Akra and Ali (2012)	D=firm value I=Company size; Voluntary disclosure Liquidity, growth	243 firm-year annual reports in Jordan (1994-2004)	Voluntary disclosure has a positive relationship with firm value. No relationship between liquidity and firm value. Size has positive relationship with firm value.
Ibrahim (2011)	Endogenous variables: disclosure, leverage, profitability Exogenous: size, financing, non-performance financing	51 banks' annual report from 2002 until 2006 in Malaysia	Leverage has a positive association with disclosure. A negative relationship between profitability and disclosure. Size and financing have a positive relationship with disclosure insignificantly.
Höring and Gründl (2011)	Dependent variable (D) Risk disclosure Independent variable (I) = Size, Profitability, Ownership dispersion, cross listing, home country, banking activities, type of insurance	31 insurance companies listed on the Dow Jones Stock in 2005-2009	A positive association between the extent of risk disclosure and firm size, cross listing status, ownership dispersion, insurer risk, banking and asset management significantly. a negative relationship between the extent of risk disclosure and profitability

Authors	Variables (D=dependent; I=independent)	Sample	Main findings
Hassan et al. (2009)	D=firm value I=size, profitability, leverage, growth, industry type, disclosure	80 non financial Egyptian listed companies in 1995-2002	Size, profitability, industry type, and mandatory disclosure have a negative association firm value significantly. Voluntary disclosure and growth have a positive insignificant relationship with firm value Leverage has an insignificant relationship with firm value.
Rajab and Handley-Schachler (2009)	D = risk disclosure I= the effect of size, leverage, industry and US dual listing	52 non-financial companies listed in the FTSE-100 index in 1998, 2001 and 2004	Risk disclosure does not have a relationship with size and leverage. Listing status and industry variables are significantly related to the level of risk disclosure.
Marshall and Weetman (2007)	D= disclosure I= market share gross margin; insider ownership; trading volume; risk evident; leverage; liquidity; cost of capital; size	40 US and 40 UK non-financial firms in 1998	A Significant positive association between disclosure and liquidity in UK firms. A significant positive relationship between disclosure and leverage and size. A negative correlation between market share, insider ownership and disclosure.

Authors	Variables (D=dependent; I=independent)	Sample	Main findings
Aljifri and Hussainey (2007)	D=forward looking disclosure I=firm size, profitability, leverage, sector type, auditor size	46 listed companies in Dubai financial market and Abu Dubai stock market in 2004	A positive correlation between leverage and level of disclosure. A negative association between profitability and level of forward looking disclosure. An insignificant association between sector type, auditor size, firm size and level of forward looking disclosure;
Linsley and Shrives (2006)	D=risk disclosure I= size, leverage ratio, beta factor, book-to- market value, quiscore, asset cover ratio, environmental risk	79 UK firms listed in FTSE 100 index, in 2000	No relationship between leverage, asset cover ratio, book-to-market value, quiscore, beta factor and risk disclosure. A positive relationship between risk disclosure and size and environmental risk.
Espinosa et al. (2005)	D=liquidity I=Disclosure Control variables: size, Volatility, effective shares volume	658 to 704 firm-year observations in Madrid Stock Exchange (MSE) between 1994 and 2000	A significant positive relationship between disclosure and liquidity.

APPENDIX B - VALIDITY AND RELIABILITY RISK KEYWORDS

Reliability Statistics

Cronbach's Alpha	Cronbach's Alpha Based on Standardized Items	N of Items
.790	.975	41

Summary Item Statistics

	Mean	Minimum	Maximum	Range	Maximum / Minimum	Variance	N of Items
Item Means	20.857	.214	251.357	251.143	1173.000	2015.944	41

Item-Total Statistics					
	Scale Mean if Item Deleted	Scale Variance if Item Deleted	Corrected Item-Total Correlation	Squared Multiple Correlation	Cronbach's Alpha if Item Deleted
aktif	842.0000	541557.692	.807	.	.786
akibat	844.7857	548501.412	.539	.	.789
ancaman	854.6429	551949.940	.794	.	.790
berbeda	852.2143	549351.874	.846	.	.789
dapat	765.4286	469019.187	.969	.	.757
mampu	841.0000	545364.462	.622	.	.787
tidakbisa	854.6429	553080.401	.044	.	.791
tidakdapat	849.5714	545605.956	.763	.	.788
boleh	854.0714	551326.379	.729	.	.790
kemungkinan	848.9286	545364.841	.800	.	.787
risiko	603.7857	354700.643	.882	.	.737
kerugian	766.1429	443313.055	.804	.	.753
potensi	844.6429	541709.170	.862	.	.786
berkurang	854.0714	551000.225	.859	.	.790
kekurangan	852.7857	551899.104	.582	.	.790
kurang	835.2143	534519.104	.833	.	.783
mengurangi	850.2143	547289.258	.856	.	.788
bermasalah	845.3571	541640.555	.892	.	.786
berubah	852.7143	552523.143	.158	.	.790
fluktuasi	854.9286	553206.225	-.062	.	.791
gangguan	853.7857	551578.797	.643	.	.790
menambah	854.0000	551190.154	.904	.	.790
kenaikan	841.9286	545135.456	.596	.	.787
kesempatan	851.3571	548623.786	.863	.	.789
mendapatkan	846.2143	537626.797	.970	.	.784
keuntungan	833.6429	523549.324	.839	.	.779
mencapai	827.0714	538150.995	.556	.	.785
perolehan	834.5714	527412.418	.761	.	.780
lindungnilai	849.9286	539472.225	.922	.	.785
masalah	849.8571	549118.440	.519	.	.789
melanggar	854.2857	551490.835	.739	.	.790
mempengaruhi	848.8571	547711.516	.808	.	.788
meningkat	828.5714	537849.495	.672	.	.784
meningkatkan	734.0000	248454.154	.764	.	.849
menurun	851.2143	551047.104	.452	.	.790
turun	852.7857	550183.720	.738	.	.789

Item-Total Statistics					
	Scale Mean if Item Deleted	Scale Variance if Item Deleted	Corrected Item-Total Correlation	Squared Multiple Correlation	Cronbach's Alpha if Item Deleted
penting	839.1429	537792.286	.819	.	.784
tertinggi	845.1429	549373.824	.484	.	.789
raguragu	854.7143	552227.297	.463	.	.790
signifikan	838.0714	539523.610	.442	.	.786
tidakstabil	849.4286	549232.418	.457	.	.789

APPENDIX C - THE BANKS AND THE DATA OF EACH VARIABLE

NO	LIS- TING	ISLA MIC	BANK	ASSET S	LDR	ROE	LEV	ER	RD	FV
1	UL	NI	ACEH	0.043	-0.020	0.050	-0.010	0.005	0.012	0.432
2	L	NI	AGRONIAGA Tbk	0.056	0.167	-0.011	-0.808	0.000	-0.019	0.007
3	L	NI	AGRONIAGA Tbk	0.043	-0.229	0.072	-0.002	0.000	-0.022	-0.091
4	L	NI	AGRONIAGA Tbk	0.007	0.077	0.034	0.019	0.000	0.054	0.046
5	L	NI	AGRONIAGA Tbk	0.040	-0.134	0.025	-0.018	0.000	0.000	0.831
6	UL	NI	AMIN-ANGLOMAS INTERNASIONAL BANK	-0.001	-0.150	-0.010	-0.074	0.000	0.000	0.008
7	UL	NI	AMIN-ANGLOMAS INTERNASIONAL BANK	-0.005	0.258	-0.039	-0.147	-0.238	-0.031	-0.002
8	UL	NI	ANDARA (D/H PT. BANK SRI PARTHA)	0.049	-1.560	0.130	0.046	0.000	0.030	0.070
9	UL	NI	ANDARA (D/H PT. BANK SRI PARTHA)	0.038	3.328	0.078	0.151	0.000	-0.040	0.066
10	UL	NI	ANDARA (D/H PT. BANK SRI PARTHA)	0.013	1.628	0.040	0.123	0.000	0.011	0.029
11	UL	NI	ANTAR DAERAH	0.018	0.020	0.020	-0.037	0.000	0.023	0.059
12	UL	NI	ANTAR DAERAH	-0.022	-0.005	-0.001	-0.018	0.000	-0.016	-0.016
13	UL	NI	ANZ PANIN BANK	0.108	0.150	0.120	-0.026	0.480	-0.011	0.840
14	UL	NI	ANZ PANIN BANK	0.755	-0.066	0.036	-0.016	-0.145	-0.021	1.352
15	L	NI	ARTHA GRAHA INTERNASIONAL Tbk	0.137	0.052	0.044	-0.876	0.000	0.016	-0.062
16	L	NI	ARTHA GRAHA INTERNASIONAL Tbk	0.212	0.061	0.000	0.032	0.000	0.013	0.022
17	L	NI	ARTHA GRAHA INTERNASIONAL Tbk	0.163	-0.079	0.042	0.001	0.000	0.004	0.012
18	L	NI	ARTHA GRAHA INTERNASIONAL Tbk	0.258	-0.090	0.006	0.009	0.000	0.001	0.946
19	UL	NI	ARTOS INDONESIA	0.007	0.040	-0.006	0.007	0.000	-0.050	0.001
20	UL	NI	ARTOS INDONESIA	0.004	-0.129	0.020	0.041	0.000	0.041	0.002
21	UL	NI	ARTOS INDONESIA	0.006	0.226	-0.017	-0.013	0.000	-0.042	0.019
22	UL	NI	ARTOS INDONESIA	0.008	-0.123	-0.007	0.067	0.000	0.021	-0.053
23	UL	NI	BALI	0.204	-0.020	0.070	-0.013	-0.012	-0.008	0.748
24	UL	NI	BALI	0.151	-0.113	0.009	0.000	0.005	-0.008	-0.263
25	UL	NI	BALI	0.247	-0.104	0.014	0.026	-0.440	0.049	1.286
26	UL	NI	BALI	0.060	0.138	0.017	-0.005	0.450	-0.071	-0.650
27	UL	NI	BANGKOK BANK COMP. LTD	0.303	-0.760	-0.030	0.027	0.000	-0.012	-0.753
28	UL	NI	BANGKOK BANK COMP. LTD	0.067	2.521	-0.002	0.012	0.000	-0.003	0.060
29	UL	NI	BANGKOK BANK COMP. LTD	0.011	-0.066	0.007	-0.023	0.000	-0.001	0.159
30	UL	NI	BANGKOK BANK COMP. LTD	-0.047	-0.206	0.005	-0.044	0.000	-0.031	0.066

NO	LIS- TING	ISLA MIC	BANK	ASSET S	LDR	ROE	LEV	ER	RD	FV
31	UL	NI	BANK OF CHINA	0.268	-0.320	-0.010	0.002	0.000	0.007	2.012
32	UL	NI	BANK OF CHINA	0.533	-0.220	0.030	0.008	0.000	0.000	0.150
33	UL	NI	BCA SYARIAH	-0.015	0.011	0.005	-0.031	0.000	-0.020	0.388
34	UL	NI	BCA SYARIAH	0.034	0.009	0.004	0.218	0.000	-0.017	-0.100
35	L	NI	BCA-CENTRAL ASIA Tbk	6.109	0.069	-0.031	-0.769	0.017	0.030	-0.011
36	L	NI	BCA-CENTRAL ASIA Tbk	5.749	0.065	0.002	-0.005	0.064	-0.004	0.025
37	L	NI	BCA-CENTRAL ASIA Tbk	4.203	0.049	0.015	-0.008	0.075	-0.001	0.055
38	L	NI	BCA-CENTRAL ASIA Tbk	3.766	-0.027	0.018	-0.007	-0.119	-0.014	1.315
39	UL	NI	BENGKULU	0.061	0.180	0.110	0.002	0.414	-0.021	0.009
40	L	NI	BII-BANK INTERNASIONAL INDONESIA Tbk	2.085	-0.021	0.066	-0.830	0.000	-0.007	-0.055
41	L	NI	BII-BANK INTERNASIONAL INDONESIA Tbk	1.979	0.060	0.020	0.016	0.000	0.014	-0.320
42	L	NI	BII-BANK INTERNASIONAL INDONESIA Tbk	1.416	0.261	0.079	-0.010	-2.881	0.000	0.303
43	L	NI	BII-BANK INTERNASIONAL INDONESIA Tbk	5.508	-0.236	-0.127	-0.055	3.294	0.009	0.289
44	UL	I	BNI SYARIAH	0.218	0.064	0.036	-0.118	0.000	0.127	0.014
45	UL	I	BNI SYARIAH	0.207	0.097	0.030	0.206	0.843	-0.004	1.178
46	L	NI	BNI-BANK NEGARA INDONESIA Tbk	3.425	0.070	-0.010	-0.743	-0.100	-0.001	-0.031
47	L	NI	BNI-BANK NEGARA INDONESIA Tbk	7.156	0.630	0.175	-0.074	0.048	-0.002	-0.154
48	L	NI	BNI-BANK NEGARA INDONESIA Tbk	-2.108	-0.571	-0.138	0.109	0.043	0.003	0.305
49	L	NI	BNI-BANK NEGARA INDONESIA Tbk	4.684	-0.045	0.073	-0.085	-0.191	-0.001	0.908
50	UL	NI	BNP INDONESIA	0.087	0.520	-0.010	0.076	-0.210	-0.077	0.348
51	UL	NI	BNP INDONESIA	0.049	-0.761	-0.004	0.133	-1.000	0.035	0.181
52	UL	NI	BNP INDONESIA	0.124	1.670	-0.119	0.330	0.000	0.053	-0.107
53	UL	NI	BNP INDONESIA	0.161	-0.311	0.083	-0.725	0.000	0.036	-0.088
54	UL	I	BRI SYARIAH	0.289	0.104	0.092	0.018	0.000	0.032	0.116
55	UL	I	BRI SYARIAH	0.434	-0.053	-0.001	0.046	0.000	0.022	0.036
56	UL	I	BRI SYARIAH	0.368	-0.252	-0.021	0.002	0.000	-0.042	0.519
57	L	NI	BRI-BANK RAKYAT INDONESIA (PERSERO) Tbk	8.144	-0.009	-0.007	-0.776	-0.095	0.031	-0.055
58	L	NI	BRI-BANK RAKYAT INDONESIA (PERSERO) Tbk	6.561	0.057	-0.086	-0.015	-0.097	-0.109	0.179

NO	LIS- TING	ISLA MIC	BANK	ASSET S	LDR	ROE	LEV	ER	RD	FV
59	L	NI	BRI-BANK RAKYAT INDONESIA (PERSERO) Tbk	8.734	-0.057	0.086	-0.005	0.049	0.037	-0.142
60	L	NI	BRI-BANK RAKYAT INDONESIA (PERSERO) Tbk	7.092	0.019	0.012	0.005	0.024	0.179	1.097
61	L	NI	BTN-BANK TABUNGAN NEGARA (PERSERO) Tbk	2.263	0.010	0.006	-0.826	-0.056	0.021	0.006
62	L	NI	BTN-BANK TABUNGAN NEGARA (PERSERO) Tbk	2.074	-0.234	0.010	0.012	-0.059	0.009	-0.077
63	L	NI	BTN-BANK TABUNGAN NEGARA (PERSERO) Tbk	0.994	0.071	0.021	-0.002	-0.146	0.004	0.082
64	L	NI	BTN-BANK TABUNGAN NEGARA (PERSERO) Tbk	1.346	0.003	-0.045	-0.024	0.000	-0.013	1.032
65	L	NI	BTPN-BANK TABUNGAN PENSUNAN NASIONAL Tbk	1.244	0.010	0.010	-0.749	0.000	-0.008	0.076
66	L	NI	BTPN-BANK TABUNGAN PENSUNAN NASIONAL Tbk	1.213	-0.060	0.303	0.002	0.000	0.006	0.357
67	L	NI	BTPN-BANK TABUNGAN PENSUNAN NASIONAL Tbk	1.225	0.060	-0.252	-0.031	0.000	-0.022	-0.138
68	L	NI	BTPN-BANK TABUNGAN PENSUNAN NASIONAL Tbk	0.857	-0.066	-0.025	0.027	0.000	0.014	1.048
69	UL	I	BUKOPIN SYARIAH	0.089	0.086	-0.546	0.018	0.000	0.009	0.188
70	UL	I	BUKOPIN SYARIAH	0.054	-0.157	0.523	-0.028	0.000	0.002	0.089
71	UL	I	BUKOPIN SYARIAH	0.022	-0.013	0.088	0.002	0.000	0.004	-0.015
72	UL	I	BUKOPIN SYARIAH	0.137	0.157	0.089	0.101	0.000	0.025	0.129
73	L	NI	BUKOPIN Tbk	0.846	-0.012	-0.006	-0.848	0.027	0.049	-0.006
74	L	NI	BUKOPIN Tbk	0.969	0.132	0.004	-0.016	-0.236	0.002	-0.019
75	L	NI	BUKOPIN Tbk	1.032	-0.041	0.032	0.007	0.211	-0.175	0.031
76	L	NI	BUKOPIN Tbk	0.454	-0.070	-0.015	-0.002	-0.177	0.137	0.950
77	L	NI	BUMI ARTA Tbk	0.052	0.104	0.029	-0.689	0.000	0.005	0.010
78	L	NI	BUMI ARTA Tbk	0.030	0.134	0.039	0.003	0.253	0.006	-0.031
79	L	NI	BUMI ARTA Tbk	0.026	0.036	-0.009	0.009	-0.008	-0.008	0.024
80	L	NI	BUMI ARTA Tbk	0.036	-0.084	-0.001	0.020	-0.245	0.020	0.729
81	L	NI	BUMIPUTERA TBK	0.015	-0.055	0.186	-0.821	0.000	0.009	0.032
82	L	NI	BUMIPUTERA TBK	-0.138	0.000	-0.207	-0.001	0.000	0.024	-0.006
83	L	NI	BUMIPUTERA TBK	0.165	-0.047	0.013	-0.005	0.000	-0.054	0.009
84	L	NI	BUMIPUTERA TBK	0.072	-0.004	-0.360	0.003	0.000	0.032	0.989

NO	LIS- TING	ISLA MIC	BANK	ASSET S	LDR	ROE	LEV	ER	RD	FV
85	L	NI	CAPITAL INDONESIA Tbk	0.097	0.148	0.033	-0.754	0.000	-0.011	-0.045
86	L	NI	CAPITAL INDONESIA Tbk	0.030	-0.064	0.001	0.869	0.000	0.037	0.919
87	L	NI	CAPITAL INDONESIA Tbk	0.094	0.040	-0.014	0.000	0.000	0.003	-0.017
88	L	NI	CAPITAL INDONESIA Tbk	0.176	-0.211	0.000	-0.886	0.000	0.027	-0.774
89	UL	NI	CENTRATAMA NASIONAL BANK	-0.011	0.050	-0.020	-0.024	0.744	-0.008	-0.095
90	UL	NI	CENTRATAMA NASIONAL BANK	0.023	-0.055	0.033	0.019	-3.916	0.005	0.115
91	UL	NI	CENTRATAMA NASIONAL BANK	0.009	-0.010	0.019	0.005	0.000	-0.159	0.009
92	UL	NI	CENTRATAMA NASIONAL BANK	0.014	-0.008	0.002	0.020	0.000	0.096	-0.001
93	UL	NI	CHINATRUST INDONESIA	0.599	1.250	0.110	0.705	1.000	0.097	1.821
94	UL	NI	CITIBANK N.A.	0.291	0.050	-0.030	0.783	0.000	-0.160	-0.327
95	UL	NI	CITIBANK N.A.	0.304	-0.032	-0.045	-0.785	0.000	0.008	0.565
96	UL	NI	CITIBANK N.A.	0.572	-0.044	-0.018	0.004	0.000	0.031	0.080
97	UL	NI	CITIBANK N.A.	-0.224	-0.054	-0.027	-0.046	0.000	0.055	2.590
98	UL	NI	COMMONWEALTH	-0.078	0.070	0.030	-0.014	0.000	0.017	-5.693
99	UL	NI	COMMONWEALTH	0.086	0.206	0.016	-0.042	0.000	0.005	6.151
100	UL	NI	COMMONWEALTH	0.030	0.127	-0.003	-0.017	0.000	0.010	0.450
101	UL	NI	COMMONWEALTH	0.238	-0.002	-0.012	0.006	0.000	-0.006	0.010
102	L	NI	DANAMON INDONESIA Tbk	1.350	0.023	-0.010	-0.635	-0.021	0.012	0.167
103	L	NI	DANAMON INDONESIA Tbk	2.409	0.045	-0.013	-0.023	0.070	-0.018	0.260
104	L	NI	DANAMON INDONESIA Tbk	1.961	0.051	0.073	0.004	0.139	0.046	0.030
105	L	NI	DANAMON INDONESIA Tbk	-0.867	0.028	-0.028	-0.040	-0.333	-0.017	0.571
106	UL	NI	DBS INDONESIA	0.921	-0.048	0.052	0.006	0.000	-0.004	5.142
107	UL	NI	DEUTSCHE BANK AG.	-0.129	0.180	-0.080	0.005	0.000	0.013	-0.136
108	UL	NI	DEUTSCHE BANK AG.	0.071	-0.024	0.129	-0.009	0.000	0.017	0.517
109	UL	NI	DIPO INTERNATIONAL BANK	0.061	-0.010	-0.090	0.035	0.000	0.071	0.047
110	UL	NI	DIPO INTERNATIONAL BANK	0.028	-0.110	0.780	-0.193	1.256	-0.262	-0.047
111	UL	NI	DIPO INTERNATIONAL BANK	0.012	-0.050	0.000	0.161	0.151	0.067	0.000
112	UL	NI	DKI	0.394	0.025	-0.019	-0.005	-0.151	0.007	0.089
113	UL	NI	DKI	0.022	0.132	0.159	0.021	0.049	0.000	-0.437
114	L	NI	EKONOMI RAHARJA Tbk	0.127	-0.028	0.118	-0.789	0.000	0.027	-0.122
115	L	NI	EKONOMI RAHARJA Tbk	0.258	-0.521	0.557	0.001	0.000	-0.013	-0.082
116	L	NI	EKONOMI RAHARJA Tbk	0.331	0.011	-0.037	-0.018	0.000	-0.026	0.878

NO	LIS- TING	ISLA MIC	BANK	ASSET S	LDR	ROE	LEV	ER	RD	FV
117	UL	NI	FAMA INTERNASIONAL	0.007	0.060	-0.050	0.001	0.000	0.176	0.067
118	UL	NI	FAMA INTERNASIONAL	0.016	-0.077	0.011	-0.122	0.000	-0.171	0.021
119	UL	NI	FAMA INTERNASIONAL	-0.007	0.047	0.002	0.235	0.000	0.043	-0.136
120	UL	NI	FAMA INTERNASIONAL	0.012	-0.023	0.073	-0.110	0.000	-0.033	0.086
121	UL	NI	GANESHA	0.014	0.030	0.000	0.003	0.000	-0.012	-0.057
122	UL	NI	GANESHA	0.034	0.022	-0.087	0.000	0.000	-0.053	0.097
123	UL	NI	GANESHA	0.009	-0.006	0.080	-0.008	0.000	0.065	-0.012
124	UL	NI	HANA	0.160	0.100	0.000	0.077	0.000	0.035	0.067
125	UL	NI	HANA	0.130	0.086	-0.015	-0.065	0.000	0.001	0.587
126	UL	NI	HANA	0.054	0.227	0.051	0.048	0.000	0.020	0.023
127	UL	NI	HANA	0.084	-0.294	-0.036	0.023	0.000	-0.034	0.210
128	UL	NI	HARDA INTERNASIONAL	0.044	0.077	0.078	-0.013	0.000	-0.137	0.110
129	L	NI	HIMPUNAN SAUDARA 1906 Tbk	0.254	0.050	0.041	-0.836	0.154	-0.018	0.117
130	L	NI	HIMPUNAN SAUDARA 1906 Tbk	0.184	0.690	0.059	0.028	0.066	0.003	-0.079
131	L	NI	HIMPUNAN SAUDARA 1906 Tbk	0.084	-0.849	-0.002	-0.016	-0.220	-0.015	0.000
132	L	NI	HIMPUNAN SAUDARA 1906 Tbk	0.043	-0.071	-0.040	-0.004	0.000	-0.213	1.047
133	UL	NI	HONGKONG & SHANGHAI B.C.	0.945	0.110	0.020	-0.020	0.000	-0.017	1.369
134	UL	NI	HONGKONG & SHANGHAI B.C.	1.241	0.044	-0.019	-0.002	0.000	-0.005	0.838
135	UL	NI	HONGKONG & SHANGHAI B.C.	0.345	0.003	0.070	-0.004	0.000	0.046	0.107
136	UL	NI	HONGKONG & SHANGHAI B.C.	-0.728	0.053	-0.030	-0.006	0.000	-0.064	-0.201
137	UL	NI	ICBC INDONESIA	0.661	-0.070	0.060	0.019	0.000	-0.027	0.159
138	UL	NI	INA PERDANA	0.007	-0.060	0.100	-0.005	0.000	0.113	0.012
139	UL	NI	INA PERDANA	0.050	0.133	-0.049	0.041	0.000	-0.087	0.014
140	UL	NI	INA PERDANA	0.010	-0.076	-0.073	0.008	0.000	-0.003	-0.002
141	UL	NI	INA PERDANA	0.018	-0.065	0.029	0.017	0.000	0.034	-0.002
142	UL	NI	INDEX SELINDO	0.058	0.030	0.120	-0.017	0.000	-0.007	0.099
143	UL	NI	INDEX SELINDO	0.098	0.036	0.000	-0.004	0.000	0.009	0.065
144	UL	NI	INDEX SELINDO	0.079	0.075	-0.002	-0.004	0.000	-0.017	-0.016
145	UL	NI	INDEX SELINDO	0.063	-0.072	0.032	0.026	0.000	0.020	0.208
146	L	NI	JABAR BANTEN Tbk	1.639	0.011	0.040	-0.773	-0.029	0.034	-0.048
147	L	NI	JABAR BANTEN Tbk	1.100	0.014	-0.040	0.016	-0.121	-0.003	-0.146
148	L	NI	JABAR BANTEN Tbk	1.104	-0.109	-0.031	-0.008	-0.306	0.001	0.316

NO	LIS- TING	ISLA MIC	BANK	ASSET S	LDR	ROE	LEV	ER	RD	FV
149	UL	NI	JABAR BANTEN Tbk	0.630	-0.070	0.026	-0.009	0.000	-0.002	-2.037
150	UL	I	JABAR SYARIAH	0.231	-0.333	-0.049	0.858	0.790	0.004	-0.090
151	UL	NI	JASA JAKARTA	0.024	0.060	0.000	-0.005	-0.035	0.007	0.076
152	UL	NI	JASA JAKARTA	0.034	-0.016	-0.016	0.005	0.695	-0.013	-0.080
153	UL	NI	JASA JAKARTA	0.055	-0.004	0.011	-0.003	-1.267	0.062	0.242
154	UL	NI	JASA JAKARTA	0.041	0.015	0.011	-0.012	0.000	-0.328	0.103
155	L	NI	JATIM (go public)	0.427	0.035	0.144	-0.680	-0.710	0.023	0.135
156	UL	NI	JATIM	0.485	-0.006	-0.215	0.006	0.552	0.007	-2.041
157	UL	NI	JATIM	0.256	0.114	0.115	-0.019	0.044	-0.017	-0.530
158	UL	NI	JATIM	0.114	0.192	-0.025	-0.007	0.004	0.014	1.570
159	UL	NI	JAWA TENGAH	0.350	0.120	0.050	-0.002	0.000	-0.001	0.371
160	UL	NI	JAWA TENGAH	0.427	-0.041	-0.010	0.001	0.000	-0.008	0.378
161	UL	NI	JAWA TENGAH	0.393	-0.151	-0.082	0.014	0.000	0.016	0.146
162	UL	NI	JP MORGAN	1.085	1.200	0.130	0.997	1.000	0.042	0.360
163	UL	NI	KALIMANTAN BARAT	0.839	0.860	0.260	0.890	0.500	0.151	1.009
164	UL	NI	KALIMANTAN SELATAN	0.187	-0.119	-0.136	0.030	-0.143	0.190	0.057
165	UL	NI	KALIMANTAN SELATAN	0.049	0.070	0.019	-0.020	-0.147	0.011	-0.018
166	UL	NI	KALIMANTAN TENGAH	0.155	-0.177	-0.018	0.008	0.003	0.066	0.192
167	UL	NI	KALIMANTAN TIMUR	0.795	-0.227	-0.091	0.033	0.000	0.051	0.537
168	UL	NI	KALIMANTAN TIMUR	0.187	-0.034	0.108	-0.019	0.000	-0.049	0.798
169	UL	NI	KALIMANTAN TIMUR	-0.172	0.511	-0.287	-0.059	0.000	0.043	0.553
170	UL	NI	KEB INDONESIA	0.131	0.221	-0.013	0.038	0.000	-0.070	0.247
171	UL	NI	KEB INDONESIA	-0.009	0.306	-0.026	-0.041	0.000	0.031	0.115
172	L	NI	KESAWAN Tbk	0.105	0.120	-0.750	-0.566	0.000	0.037	-0.127
173	L	NI	KESAWAN Tbk	0.100	0.034	0.712	-0.086	0.000	-0.037	0.436
174	L	NI	KESAWAN Tbk	0.024	0.047	-0.025	-0.086	0.000	0.019	-0.102
175	L	NI	KESAWAN Tbk	0.019	-0.077	0.004	-0.013	0.000	-0.014	0.652
176	UL	NI	KESEJAHTERAAN EKONOMI	0.054	-0.060	-0.010	0.003	0.265	0.012	0.077
177	UL	NI	KESEJAHTERAAN EKONOMI	0.047	-0.053	0.023	0.010	1.135	0.000	-0.010
178	UL	NI	LIMAN INTERNATIONAL BANK	0.052	1.010	0.020	0.588	1.000	0.065	0.222
179	UL	NI	MALUKU	0.102	-0.040	-0.050	-0.003	0.200	0.017	0.161
180	UL	NI	MALUKU	0.106	-0.207	0.099	0.001	0.189	-0.038	0.053
181	UL	NI	MALUKU	0.049	0.081	0.000	0.013	-0.139	0.032	0.000

NO	LIS- TING	ISLA MIC	BANK	ASSET S	LDR	ROE	LEV	ER	RD	FV
182	L	NI	MANDIRI (PERSERO) Tbk	7.400	0.060	0.020	-0.800	-0.102	0.031	0.043
183	L	NI	MANDIRI (PERSERO) Tbk	3.933	0.034	0.006	-0.027	0.152	-0.019	-0.009
184	L	NI	MANDIRI (PERSERO) Tbk	5.516	0.062	0.023	-0.004	-0.057	-0.006	0.050
185	L	NI	MANDIRI (PERSERO) Tbk	3.618	-0.132	0.040	-0.004	0.056	-0.002	1.061
186	UL	I	MANDIRI SYARIAH	0.556	0.094	0.008	-0.131	0.000	-0.001	9.545
187	UL	I	MANDIRI SYARIAH	1.619	0.098	-0.394	-0.787	0.000	0.007	1.623
188	UL	I	MANDIRI SYARIAH	1.045	0.023	0.194	0.013	0.000	-0.079	0.607
189	UL	I	MANDIRI SYARIAH	0.497	-0.162	-0.018	-0.011	0.000	0.051	-0.291
190	L	NI	MAYAPADA INTERNASIONAL Tbk	0.285	0.616	-0.263	0.018	-0.491	0.003	-0.047
191	L	NI	MAYAPADA INTERNASIONAL Tbk	0.459	-0.798	0.329	0.026	0.000	0.008	0.823
192	UL	I	MAYBANK SYARIAH	0.037	-0.915	0.000	0.077	0.000	0.162	0.050
193	UL	NI	MAYORA	0.077	0.070	0.017	-0.021	0.000	-0.024	0.048
194	UL	I	MEGA SYARIAH	0.260	0.720	0.411	0.665	0.000	0.012	1.004
195	UL	I	MEGA SYARIAH	0.093	-0.613	-0.099	0.026	0.000	-0.003	0.046
196	UL	I	MEGA SYARIAH	0.026	-0.032	-0.132	-0.395	0.000	0.050	0.094
197	UL	I	MEGA SYARIAH	0.129	0.020	0.290	-0.220	0.000	-0.010	-1.048
198	L	NI	MEGA Tbk	0.331	-0.114	0.007	-0.825	0.000	0.006	-0.027
199	L	NI	MEGA Tbk	1.021	0.077	-0.005	0.008	0.526	-0.005	-0.080
200	L	NI	MEGA Tbk	0.010	-0.008	0.085	0.210	-0.526	0.014	0.264
201	L	NI	MEGA Tbk	1.674	-0.079	0.000	-0.214	0.000	0.030	0.843
202	UL	NI	METRO EKSPRESS	0.076	0.786	0.016	0.720	1.000	0.148	0.221
203	UL	NI	MITRANIAGA	0.055	0.518	0.022	0.812	1.000	0.089	0.015
204	UL	I	MUAMALAT	1.237	0.090	0.092	-0.054	0.000	-0.005	0.941
205	UL	I	MUAMALAT	1.104	-0.063	0.022	0.081	2.991	0.000	-0.222
206	UL	I	MUAMALAT	0.542	0.057	0.098	-0.026	-0.996	0.006	0.875
207	UL	I	MUAMALAT	0.343	-0.186	-0.713	0.021	-1.535	0.025	0.062
208	UL	NI	MULTI ARTA SENTOSA (MAS)	0.007	-0.120	0.000	0.002	0.000	0.011	0.015
209	L	NI	MUTIARA Tbk	0.211	-0.010	-0.190	-0.842	0.000	-0.024	-357.117
210	L	NI	MUTIARA Tbk	0.234	0.121	-0.055	-0.005	0.000	0.045	-559.723
211	L	NI	MUTIARA Tbk	0.325	-0.108	-3.633	0.004	0.000	-0.014	- 1354.24 9
212	L	NI	MUTIARA Tbk	0.195	-0.115	4.550	0.565	0.000	0.027	4490.34 8
213	UL	NI	NATIONALNOBU (ALFINDO SEJAHTERA)	0.088	-0.120	0.000	0.179	0.000	0.010	0.129

NO	LIS- TING	ISLA MIC	BANK	ASSET S	LDR	ROE	LEV	ER	RD	FV
214	UL	NI	NATIONALNOBU (ALFINDO SEJAHTERA)	0.020	-0.151	-0.010	0.499	0.000	-0.049	0.014
215	L	NI	NIAGA Tbk	3.061	0.006	0.012	-0.775	0.063	0.018	-0.048
216	L	NI	NIAGA Tbk	2.315	0.856	0.017	-0.014	-0.063	-0.012	-0.148
217	L	NI	NIAGA Tbk	3.655	-0.863	0.052	0.009	0.195	0.008	0.168
218	L	NI	NIAGA Tbk	0.391	0.073	0.080	-0.014	0.209	0.004	0.300
219	UL	NI	NTB-NUSA TENGGARA BARAT	0.065	0.070	0.025	-0.225	-0.083	0.043	0.120
220	UL	NI	NTB-NUSA TENGGARA BARAT	0.071	-0.008	-0.036	0.227	0.002	-0.038	-0.188
221	UL	NI	NTB-NUSA TENGGARA BARAT	0.054	-0.133	0.140	-0.005	0.147	0.006	0.590
222	UL	NI	NTB-NUSA TENGGARA BARAT	0.034	-0.130	-0.009	0.013	-0.178	-0.013	-2.739
223	UL	NI	NTT-NUSA TENGGARA TIMUR	0.133	0.010	0.020	0.003	0.005	-0.008	0.170
224	UL	NI	NTT-NUSA TENGGARA TIMUR	0.112	0.002	0.028	0.012	-0.622	0.010	-0.406
225	UL	NI	NTT-NUSA TENGGARA TIMUR	0.110	-0.310	0.032	0.016	0.684	-0.123	0.098
226	L	NI	NUSANTARA PARAHYANGAN Tbk	0.165	-0.010	0.020	-0.831	0.040	-0.013	-0.008
227	L	NI	NUSANTARA PARAHYANGAN Tbk	0.128	0.046	0.003	0.009	-0.104	0.008	-0.006
228	L	NI	NUSANTARA PARAHYANGAN Tbk	0.139	0.068	0.032	-0.003	0.000	0.014	-0.006
229	L	NI	NUSANTARA PARAHYANGAN Tbk	0.020	0.075	-0.005	-0.003	0.000	0.014	0.945
230	L	NI	OCBC NISP Tbk	1.931	-0.002	-0.007	-0.777	0.000	0.027	0.027
231	L	NI	OCBC NISP Tbk	1.536	0.091	0.053	-0.008	0.000	-0.004	-0.103
232	L	NI	OCBC NISP Tbk	0.742	0.056	-0.042	0.010	0.000	0.010	0.075
233	UL	NI	OCBC NISP Tbk	0.281	-0.043	0.027	-0.006	0.000	0.002	-1.285
234	L	NI	PAN INDONESIA Tbk	2.404	0.080	0.010	-0.754	0.000	0.005	-0.040
235	L	NI	PAN INDONESIA Tbk	1.581	0.058	0.012	-0.005	0.000	-0.008	-0.107
236	L	NI	PAN INDONESIA Tbk	3.109	0.009	0.024	0.027	0.000	0.009	0.044
237	L	NI	PAN INDONESIA Tbk	1.347	-0.057	0.002	-0.014	0.000	0.008	0.902
238	UL	I	PANIN SYARIAH	0.112	-0.391	0.050	0.445	0.000	0.019	0.228
239	UL	I	PANIN SYARIAH	0.056	0.932	0.075	-0.133	0.000	0.022	0.020
240	UL	NI	PAPUA	0.109	0.230	-0.040	-0.008	0.435	-0.022	0.230
241	L	NI	PERMATA Tbk	3.047	0.065	0.017	-0.815	0.000	-0.002	-0.019
242	L	NI	PERMATA Tbk	2.751	-0.042	-0.056	0.018	0.000	0.002	-0.028
243	L	NI	PERMATA Tbk	1.780	-0.033	0.082	-0.021	0.000	-0.006	0.035
244	L	NI	PERMATA Tbk	0.195	0.088	0.009	-0.007	0.000	0.003	0.953
245	UL	NI	PRIMA MASTER BANK	0.051	0.100	0.020	-0.622	3.048	0.024	0.083

NO	LIS- TING	ISLA MIC	BANK	ASSET S	LDR	ROE	LEV	ER	RD	FV
246	L	NI	PUNDI INDONESIA Tbk	0.169	0.169	0.601	-0.838	0.000	0.007	0.448
247	L	NI	PUNDI INDONESIA Tbk	0.443	0.140	0.339	0.259	0.000	0.002	0.000
248	UL	NI	PURBA DANARTA	0.042	0.880	0.990	0.611	1.000	0.066	0.167
249	UL	NI	RABO BANK (MERG HG & HGKT	0.100	-0.054	0.007	-0.049	0.000	0.001	0.476
250	UL	NI	RABO BANK (MERG HG & HGKT	0.081	-0.210	-0.030	0.046	0.000	0.027	-0.673
251	UL	NI	RBS ROYAL BANK SCOTLAND	0.507	1.307	0.017	0.771	1.000	0.182	1.178
252	UL	NI	RESONA PERDANIA	0.165	0.070	0.000	0.005	0.000	-0.011	1.080
253	UL	NI	RESONA PERDANIA	0.245	-0.047	0.007	0.025	0.000	0.015	0.401
254	UL	NI	RESONA PERDANIA	0.124	0.245	0.024	0.007	0.000	0.003	0.058
255	UL	NI	RESONA PERDANIA	-0.081	-0.171	0.004	-0.035	0.000	0.032	0.008
256	UL	NI	RIAU	0.959	-0.222	-0.048	0.023	0.000	-0.117	0.574
257	UL	NI	RIAU	-0.288	0.452	-0.053	-0.039	0.000	0.164	0.011
258	UL	NI	ROYAL INDONESIA	0.001	0.300	0.000	0.001	0.000	0.071	-1.197
259	UL	NI	SBI INDONESIA	0.026	0.110	-0.050	0.004	0.000	0.006	-0.258
260	UL	NI	SBI INDONESIA	0.052	-0.094	0.055	0.017	0.000	-0.038	0.120
261	UL	NI	SBI INDONESIA	0.045	0.315	0.024	0.035	0.002	0.007	0.009
262	UL	NI	SINAR HARAPAN BALI	0.003	-0.012	0.010	-0.011	0.000	-0.029	0.017
263	UL	NI	SINAR HARAPAN BALI	0.013	-0.168	-0.027	0.005	0.000	0.008	0.052
264	L	NI	SINAR MAS Tbk	0.392	0.071	0.001	-0.798	0.000	-0.006	-0.149
265	L	NI	SINAR MAS Tbk	0.320	-0.054	0.069	-0.010	0.000	0.040	0.252
266	UL	NI	SINAR MAS Tbk	0.197	-0.043	0.046	0.005	0.010	-0.058	0.309
267	UL	NI	STANDARD CHARTERED BANK	0.319	0.200	-0.010	0.065	0.000	0.064	3.827
268	UL	NI	STANDARD CHARTERED BANK	0.790	-0.138	0.075	0.018	0.000	0.006	-0.475
269	UL	NI	STANDARD CHARTERED BANK	0.088	0.175	-0.064	-0.025	0.000	-0.004	-4.610
270	UL	NI	STANDARD CHARTERED BANK	-0.897	0.003	-0.021	-0.004	0.000	-0.009	0.666
271	UL	NI	SULAWESI SELATAN	0.107	0.113	-0.001	-0.013	-0.011	0.004	0.239
272	UL	NI	SULAWESI SELATAN	0.068	-0.081	0.005	-0.006	-0.026	-0.005	-0.626
273	UL	NI	SULAWESI TENGAH	0.115	0.770	0.150	0.828	1.000	0.082	0.213
274	UL	NI	SULAWESI TENGGARA	0.307	0.920	0.330	1.056	1.000	0.043	0.498
275	UL	NI	SULAWESI UTARA	0.432	1.050	0.325	0.934	0.448	0.063	0.585
276	UL	NI	SUMATERA BARAT	0.148	0.090	0.010	-0.011	0.796	0.003	0.490
277	UL	NI	SUMATERA BARAT	0.253	0.066	-0.031	0.008	-0.039	0.039	0.003
278	UL	NI	SUMATERA BARAT	0.223	-0.033	0.110	0.008	0.101	-0.034	0.767

NO	LIS- TING	ISLA MIC	BANK	ASSET S	LDR	ROE	LEV	ER	RD	FV
279	UL	NI	SUMATERA BARAT	0.132	-0.053	-0.029	0.010	-0.008	0.023	-0.440
280	UL	NI	SUMATERA SELATAN	0.255	0.000	-0.090	0.000	0.055	0.000	0.748
281	UL	NI	SUMATERA SELATAN	0.505	0.220	0.040	-0.013	0.700	-0.031	0.800
282	UL	NI	SUMATERA UTARA	0.101	0.230	0.010	0.000	0.015	-0.097	-0.320
283	UL	NI	SUMATERA UTARA	0.619	-0.130	-0.090	0.028	0.017	0.117	0.756
284	UL	NI	SUMITOMO MITSUI INDONESIA	1.099	-0.060	0.000	0.064	-0.086	0.000	0.843
285	L	NI	SWADESI/BANK OF INDIA Tbk	0.046	0.275	0.016	-0.686	0.000	0.222	0.243
286	L	NI	SWADESI/BANK OF INDIA Tbk	0.051	-0.217	0.036	0.036	0.600	-0.149	-0.097
287	L	NI	SWADESI/BANK OF INDIA Tbk	0.001	0.063	-0.017	0.004	-0.600	0.090	0.001
288	L	NI	SWADESI/BANK OF INDIA Tbk	0.020	-0.020	0.029	0.001	0.000	-0.043	0.984
289	UL	NI	TOKYO-MITSUBISHI LTD.	6.214	2.500	0.020	0.881	1.000	0.057	8.323
290	UL	NI	UOB BUANA	0.412	0.050	0.030	-0.009	0.322	0.383	0.000
291	UL	NI	UOB BUANA	1.695	-0.061	-0.035	0.045	-0.157	0.000	1.840
292	UL	NI	UOB BUANA	0.487	0.076	0.015	0.002	0.231	0.039	0.574
293	UL	NI	UOB BUANA	1.219	-0.015	0.040	-0.001	-0.043	-0.059	2.490
294	L	NI	VICTORIA INTERNATIONAL Tbk	0.255	0.040	-0.084	-0.795	0.000	-0.005	-0.018
295	L	NI	VICTORIA INTERNATIONAL Tbk	0.150	0.234	0.065	0.896	0.000	0.000	0.904
296	L	NI	VICTORIA INTERNATIONAL Tbk	0.295	-0.102	0.104	0.000	0.001	0.005	-0.009
297	L	NI	VICTORIA INTERNATIONAL Tbk	0.173	-0.030	0.002	-0.905	-0.001	-0.004	-0.301
298	UL	I	VICTORIA SYARIAH	0.030	0.102	-0.157	0.733	0.000	0.053	1.630
299	UL	I	VICTORIA SYARIAH	0.031	0.467	0.225	-0.488	0.000	-0.062	-0.030
300	L	NI	WINDU KENCANA INTERNATIONAL	0.004	0.010	0.090	-0.797	0.000	-0.010	-0.020
301	L	NI	WINDU KENCANA INTERNATIONAL	0.210	-0.023	-0.012	0.033	0.000	-0.020	0.013
302	L	NI	WINDU KENCANA INTERNATIONAL	0.156	0.157	0.012	-0.012	0.000	0.010	0.008
303	L	NI	WINDU KENCANA INTERNATIONAL	0.070	-0.205	0.046	0.017	0.000	0.047	0.880
304	UL	NI	WOORI INDONESIA	0.018	0.520	-0.030	-0.015	0.000	-0.007	-0.199
305	UL	NI	WOORI INDONESIA	0.120	-0.194	0.000	0.041	0.000	-0.185	0.373
306	UL	NI	WOORI INDONESIA	0.060	0.079	-0.021	0.018	0.000	0.006	0.211
307	UL	NI	WOORI INDONESIA	-0.007	-0.122	-0.007	-0.041	0.000	0.017	0.110
308	UL	NI	YOGYAKARTA	0.080	-0.070	0.010	0.006	-0.004	0.003	0.029
309	UL	NI	YOGYAKARTA	0.132	-0.013	0.000	0.005	0.143	-0.007	0.029

NO	LIS- TING	ISLA MIC	BANK	ASSET S	LDR	ROE	LEV	ER	RD	FV
310	UL	NI	YOGYAKARTA	0.073	0.043	-0.050	0.012	0.001	0.013	0.000
311	UL	NI	YUDHA BHAKTI	0.027	0.110	-0.010	-0.005	-0.145	0.037	1.554
312	UL	NI	YUDHA BHAKTI	0.012	0.000	-0.072	0.004	-0.475	-0.008	-0.089

APPENDIX D - FREE OF HETEROCEDASTICITY

The association between the delta of firm characteristics and the delta of risk disclosure in ALL BANKS

Coefficients^a

Model	Unstandardized Coefficients		Standardized Coefficients	t	Sig.	Collinearity Statistics	
	B	Std. Error	Beta			Tolerance	VIF
1 (Constant)	.036	.003		11.393	.000		
asset	-.001	.002	-.042	-.724	.469	.961	1.041
ldr	.003	.007	.021	.353	.724	.912	1.097
roe	.002	.008	.011	.200	.841	.986	1.015
leverage	.012	.009	.085	1.405	.161	.880	1.137
earnings	.007	.006	.066	1.141	.255	.953	1.050

a. Dependent Variable: abs_risk

The association between the delta of firm characteristics and the delta of risk disclosure and the delta of firm value in ALL BANKS

Coefficients^a

Model	Unstandardized Coefficients		Standardized Coefficients	t	Sig.	Collinearity Statistics	
	B	Std. Error	Beta			Tolerance	VIF
1 (Constant)	.037	.003		11.753	.000		
assets	-.004	.002	-.114	-1.968	.050	.959	1.043
ldr	-.003	.007	-.025	-.421	.674	.903	1.107
roe	.004	.008	.030	.529	.597	.985	1.015
leverage	-.010	.009	-.069	-1.132	.258	.875	1.142
earningreiv	.000	.006	-.002	-.030	.976	.953	1.050
riskdisc	-.024	.046	-.030	-.518	.605	.979	1.021

a. Dependent Variable: ABS_RES

The association between the delta of firm characteristics and the delta of risk disclosure in LISTED BANKS

Coefficients^a

Model	Unstandardized Coefficients		Standardized Coefficients	t	Sig.	Collinearity Statistics	
	B	Std. Error	Beta			Tolerance	VIF
1 (Constant)	.027	.005		5.471	.000		
asset	.000	.002	.025	.256	.799	.959	1.043
ldr	.005	.017	.028	.286	.776	.952	1.051
roe	-.001	.007	-.016	-.168	.867	.986	1.014
leverage	.008	.010	.076	.796	.428	.978	1.022
earningsre	.004	.009	.041	.421	.674	.943	1.060

a. Dependent Variable: ABS_RISK_LISTED

The association between the delta of firm characteristics and the delta of risk disclosure and the delta of firm value in LISTED BANKS

Coefficients^a

Model	Unstandardized Coefficients		Standardized Coefficients	t	Sig.	Collinearity Statistics	
	B	Std. Error	Beta			Tolerance	VIF
1 (Constant)	112.263	21.846		5.139	.000		
asset	-11.388	8.382	-.129	-1.359	.177	.952	1.050
ldr	-18.696	77.196	-.023	-.242	.809	.949	1.054
roe	46.785	29.955	.146	1.562	.121	.983	1.017
leverage	60.078	43.216	.131	1.390	.167	.969	1.032
earningsre	11.905	39.502	.029	.301	.764	.938	1.066
riskdisc	177.475	357.598	.047	.496	.621	.971	1.030

a. Dependent Variable: ABS_FIRM_LISTED

The association between the delta of firm characteristics and the delta of risk disclosure in UNLISTED BANKS

Coefficients^a

Model	Unstandardized Coefficients		Standardized Coefficients	t	Sig.	Collinearity Statistics	
	B	Std. Error	Beta			Tolerance	VIF
1 (Constant)	.041	.004		9.662	.000		
asset	-.006	.007	-.064	-.847	.398	.896	1.116
ldr	-.004	.009	-.038	-.465	.643	.786	1.272
roe	.030	.028	.081	1.072	.285	.897	1.115
leverage	.008	.016	.037	.462	.645	.785	1.273
earningsre	.006	.008	.059	.768	.443	.880	1.136

a. Dependent Variable: ABS_RISK_UNLISTED

The association between the delta of firm characteristics and the delta of risk disclosure and the delta of firm value in UNLISTED BANKS

Coefficients^a

Model	Unstandardized Coefficients		Standardized Coefficients	t	Sig.	Collinearity Statistics	
	B	Std. Error	Beta			Tolerance	VIF
1 (Constant)	.506	.084		6.036	.000		
asset	.171	.148	.088	1.151	.251	.896	1.116
ldr	.035	.174	.016	.200	.842	.784	1.276
roe	-.185	.564	-.025	-.327	.744	.876	1.142
leverage	-.278	.331	-.070	-.842	.401	.755	1.324
earningre	-.004	.149	-.002	-.028	.978	.879	1.137
riskdisc	.386	1.136	.025	.339	.735	.931	1.074

a. Dependent Variable: ABS_FIRM_UNLISTED

The association between the delta of firm characteristics and the delta of risk disclosure in ISLAMIC BANKS

Coefficients^a

Model	Unstandardized Coefficients		Standardized Coefficients	t	Sig.	Collinearity Statistics	
	B	Std. Error	Beta			Tolerance	VIF
1 (Constant)	.037	.008		4.756	.000		
asset	-.013	.015	-.203	-.883	.387	.781	1.280
ldr	-.023	.016	-.294	-1.389	.179	.918	1.090
roe	.012	.024	.106	.482	.635	.850	1.176
leverage	-.017	.018	-.204	-.915	.371	.826	1.211
earngre	-.001	.009	-.028	-.126	.901	.825	1.212

a. Dependent Variable: ABS_RISK_ISLM

The association between the delta of firm characteristics and the delta of risk disclosure and the delta of firm value in ISLAMIC BANKS

Coefficients^a

Model	Unstandardized Coefficients		Standardized Coefficients	t	Sig.	Collinearity Statistics	
	B	Std. Error	Beta			Tolerance	VIF
1 (Constant)	.671	.547		1.228	.234		
asset	.424	.997	.111	.425	.675	.720	1.388
ldr	.380	1.075	.084	.354	.727	.852	1.174
roe	-.162	1.537	-.025	-.105	.917	.826	1.210
leverage	-.110	1.139	-.023	-.096	.924	.826	1.211
earnings	-.059	.544	-.027	-.109	.914	.825	1.212
riskdis	-.784	8.279	-.023	-.095	.926	.806	1.241

a. Dependent Variable: ABS_FIRM_ISL

The association between the delta of firm characteristics and the delta of risk disclosure in NON-ISLAMIC BANKS

Coefficients^a

Model	Unstandardized Coefficients		Standardized Coefficients	t	Sig.	Collinearity Statistics	
	B	Std. Error	Beta			Tolerance	VIF
1 (Constant)	.037	.008		4.756	.000		
asset	-.013	.015	-.203	-.883	.387	.781	1.280
ldr	-.023	.016	-.294	-1.389	.179	.918	1.090
roe	.012	.024	.106	.482	.635	.850	1.176
leverage	-.017	.018	-.204	-.915	.371	.826	1.211
earngre	-.001	.009	-.028	-.126	.901	.825	1.212

a. Dependent Variable: ABS_RISK_ISLM

The association between the delta of firm characteristics and the delta of risk disclosure and the delta of firm value in NON-ISLAMIC BANKS

Coefficients^a

Model	Unstandardized Coefficients		Standardized Coefficients	t	Sig.	Collinearity Statistics	
	B	Std. Error	Beta			Tolerance	VIF
1 (Constant)	60.747	9.278		6.547	.000		
asset	-3.209	5.560	-.036	-.577	.564	.955	1.047
ldr	-5.731	20.377	-.018	-.281	.779	.874	1.145
leverage	37.640	25.557	.097	1.473	.142	.870	1.150
earningsre	13.431	16.977	.050	.791	.430	.948	1.055
riskdisc	-.275	131.505	.000	-.002	.998	.973	1.028
inv_roe	-.017	.047	-.023	-.373	.709	.993	1.007

a. Dependent Variable: ABS_FIRM_NONISL

APPENDIX E - THE BANKS WERE EXCLUDED

NO.	LISTING	ISLAMIC	YEAR	BANK	NOTE
1	UL	NIB	2008	JAMBI	blank
2	UL	NIB	2008	KALIMANTAN SELATAN	blank
3	UL	NIB	2008	MASPION	blank
4	UL	NIB	2008	SBI INDONESIA	blank
5	UL	NIB	2009	JAMBI	blank
6	UL	NIB	2009	MASPION	blank
7	UL	NIB	2010	JAMBI	blank
8	UL	NIB	2010	MASPION	blank
9	UL	NIB	2010	YOGYAKARTA	blank
10	UL	NIB	2011	HARDA INTERNASIONAL	blank
11	UL	NIB	2011	JAMBI	blank
12	UL	NIB	2011	MASPION	blank
13	UL	NIB	2011	SULAWESI UTARA	blank
14	UL	NIB	2012	BANK OF AMERICA	blank
15	UL	NIB	2012	JAMBI	blank
16	L	NIB	2012	MAYAPADA INTERNASIONAL Tbk	blank
17	UL	I	2008	BRI SYARIAH	cannot be converted
18	L	NIB	2011	SINAR MAS Tbk	cannot be converted
19	UL	NIB	2012	KALIMANTAN SELATAN	cannot be converted
20	UL	NIB	2012	SULAWESI UTARA	cannot be converted
21	UL	NIB	2008	KALIMANTAN BARAT	cannot be downloaded
22	UL	NIB	2009	KALIMANTAN BARAT	cannot be downloaded
23	UL	NIB	2009	RABO BANK (MERG HG & HGKT)	cannot be downloaded
24	UL	NIB	2010	ACEH	cannot be downloaded
25	UL	NIB	2010	PAPUA	cannot be downloaded
26	UL	NIB	2010	PRIMA MASTER BANK	cannot be downloaded
27	UL	NIB	2010	RIAU	cannot be downloaded
28	UL	NIB	2011	KALIMANTAN BARAT	cannot be downloaded
29	UL	NIB	2011	KALIMANTAN TENGAH	cannot be downloaded
30	UL	NIB	2011	MITRANIAGA	cannot be downloaded
31	UL	NIB	2011	RABO BANK (MERG HG & HGKT)	cannot be downloaded
32	UL	NIB	2011	RIAU	cannot be downloaded
33	UL	NIB	2012	CHINATRUST INDONESIA	cannot be downloaded
34	UL	NIB	2012	MITRANIAGA	cannot be downloaded

NO.	LISTING	ISLAMIC	YEAR	BANK	NOTE
35	UL	NIB	2010	KALIMANTAN BARAT	damaged
36	UL	NIB	2011	KEB INDONESIA	damaged
37	UL	NIB	2012	DKI	damaged
38	UL	NIB	2012	KALIMANTAN TIMUR	damaged
39	UL	I	2008	BCA SYARIAH	has not established yet
40	UL	I	2008	BNI SYARIAH	has not established yet
41	UL	I	2008	JABAR SYARIAH	has not established yet
42	UL	I	2008	MAYBANK SYARIAH	has not established yet
43	UL	I	2008	PANIN SYARIAH	has not established yet
44	UL	I	2008	VICTORIA SYARIAH	has not established yet
45	UL	I	2009	BCA SYARIAH	has not established yet
46	UL	I	2009	BNI SYARIAH	has not established yet
47	UL	I	2009	JABAR SYARIAH	has not established yet
48	UL	I	2009	MAYBANK SYARIAH	has not established yet
49	UL	I	2009	VICTORIA SYARIAH	has not established yet
50	L	NIB	2008	PUNDI INDONESIA Tbk	na
51	UL	NIB	2008	ACEH	na
52	UL	NIB	2008	AGRIS	na
53	UL	NIB	2008	AMIN-ANGLOMAS INTERNASIONAL BANK	na
54	UL	NIB	2008	ANDARA (D/H PT. BANK SRI PARTHA)	na
55	UL	NIB	2008	ANTAR DAERAH	na
56	UL	NIB	2008	ANZ PANIN BANK	na
57	UL	NIB	2008	BANK OF AMERICA	na
58	UL	NIB	2008	BANK OF CHINA	na
59	UL	NIB	2008	BENGKULU	na
60	UL	NIB	2008	BISNIS INTERNASIONAL	na
61	UL	NIB	2008	CHINATRUST INDONESIA	na
62	UL	NIB	2008	DBS INDONESIA	na
63	UL	NIB	2008	DEUTSCHE BANK	na
64	UL	NIB	2008	DIPO INTERNATIONAL BANK	na
65	UL	NIB	2008	DKI	na
66	UL	NIB	2008	GANESHA	na
67	UL	NIB	2008	HARDA INTERNASIONAL	na
68	UL	NIB	2008	ICBC INDONESIA	na
69	UL	NIB	2008	JAWA TENGAH	na
70	UL	NIB	2008	JP MORGAN	na

NO.	LISTING	ISLAMIC	YEAR	BANK	NOTE
71	UL	NIB	2008	KALIMANTAN TENGAH	na
72	UL	NIB	2008	KEB INDONESIA	na
73	UL	NIB	2008	KESEJAHTERAAN EKONOMI	na
74	UL	NIB	2008	LAMPUNG	na
75	UL	NIB	2008	LIMAN INTERNATIONAL BANK (dinar)	na
76	UL	NIB	2008	MALUKU	na
77	UL	NIB	2008	MAYORA	na
78	UL	NIB	2008	MESTIKA DHARMA	na
79	UL	NIB	2008	METRO EKSPRESS	na
80	UL	NIB	2008	MITRANIAGA	na
81	UL	NIB	2008	MIZUHO	na
82	UL	NIB	2008	MULTI ARTA SENTOSA (MAS)	na
83	UL	NIB	2008	NATIONALNOBU (ALFINDO SEJAHTERA)	na
84	UL	NIB	2008	NTT-NUSA TENGGARA TIMUR	na
85	UL	NIB	2008	PAPUA	na
86	UL	NIB	2008	PRIMA MASTER BANK	na
87	UL	NIB	2008	PURBA DANARTA	na
88	UL	NIB	2008	ROYAL BANK SCOTLAND	na
89	UL	NIB	2008	ROYAL INDONESIA	na
90	UL	NIB	2008	SINAR HARAPAN BALI	na
91	UL	NIB	2008	SULAWESI SELATAN	na
92	UL	NIB	2008	SULAWESI TENGAH	na
93	UL	NIB	2008	SULAWESI TENGGARA	na
94	UL	NIB	2008	SULAWESI UTARA	na
95	UL	NIB	2008	SUMATERA UTARA	na
96	UL	NIB	2008	SUMITOMO MITSUI INDONESIA	na
97	UL	NIB	2008	TOKYO-MITSUBISHI LTD.	na
98	UL	NIB	2008	YUDHA BHAKTI	na
99	UL	NIB	2009	ACEH	na
100	UL	NIB	2009	AGRIS	na
101	UL	NIB	2009	AMIN-ANGLOMAS INTERNASIONAL BANK	na
102	UL	NIB	2009	ANTAR DAERAH	na
103	UL	NIB	2009	ANZ PANIN BANK	na
104	UL	NIB	2009	BANK OF AMERICA	na
105	UL	NIB	2009	BANK OF CHINA	na

NO.	LISTING	ISLAMIC	YEAR	BANK	NOTE
106	UL	NIB	2009	BENGKULU	na
107	UL	NIB	2009	BISNIS INTERNASIONAL	na
108	UL	NIB	2009	CHINATRUST INDONESIA	na
109	UL	NIB	2009	DBS INDONESIA	na
110	UL	NIB	2009	DEUTSCHE BANK	na
111	L	NIB	2009	EKONOMI RAHARJA Tbk	na
112	UL	NIB	2009	ICBC INDONESIA	na
113	UL	NIB	2009	JP MORGAN	na
114	UL	NIB	2009	KALIMANTAN TENGAH	na
115	UL	NIB	2009	KESEJAHTERAAN EKONOMI	na
116	UL	NIB	2009	LAMPUNG	na
117	UL	NIB	2009	LIMAN INTERNATIONAL BANK	na
118	L	NIB	2009	MAYAPADA INTERNASIONAL Tbk	na
119	UL	NIB	2009	MAYORA	na
120	UL	NIB	2009	MESTIKA DHARMA	na
121	UL	NIB	2009	METRO EKSPRESS	na
122	UL	NIB	2009	MITRANIAGA	na
123	UL	NIB	2009	MIZUHO	na
124	UL	NIB	2009	MULTI ARTA SENTOSA (MAS)	na
125	UL	NIB	2009	NATIONALNOBU (ALFINDO SEJAHTERA)	na
126	UL	I	2009	PANIN SYARIAH	na
127	UL	NIB	2009	PAPUA	na
128	UL	NIB	2009	PRIMA MASTER BANK	na
129	L	NIB	2009	PUNDI INDONESIA Tbk	na
130	UL	NIB	2009	PURBA DANARTA	na
131	UL	NIB	2009	ROYAL BANK SCOTLAND	na
132	UL	NIB	2009	ROYAL INDONESIA	na
133	UL	NIB	2009	SINAR HARAPAN BALI	na
134	UL	NIB	2009	SULAWESI SELATAN	na
135	UL	NIB	2009	SULAWESI TENGAH	na
136	UL	NIB	2009	SULAWESI TENGGARA	na
137	UL	NIB	2009	SULAWESI UTARA	na
138	UL	NIB	2009	SUMATERA SELATAN	na
139	UL	NIB	2009	SUMATERA UTARA	na
140	UL	NIB	2009	SUMITOMO MITSUI INDONESIA	na
141	UL	NIB	2009	TOKYO-MITSUBISHI LTD.	na

NO.	LISTING	ISLAMIC	YEAR	BANK	NOTE
142	UL	NIB	2009	YUDHA BHAKTI	na
143	UL	NIB	2010	AGRIS	na
144	UL	NIB	2010	BANK OF AMERICA	na
145	UL	NIB	2010	BENGKULU	na
146	UL	NIB	2010	BISNIS INTERNASIONAL	na
147	UL	NIB	2010	CHINATRUST INDONESIA	na
148	UL	NIB	2010	DBS INDONESIA	na
149	UL	NIB	2010	HARDA INTERNASIONAL	na
150	UL	NIB	2010	ICBC INDONESIA	na
151	UL	NIB	2010	JP MORGAN	na
152	UL	NIB	2010	LAMPUNG	na
153	UL	NIB	2010	LIMAN INTERNATIONAL BANK	na
154	UL	I	2010	MAYBANK SYARIAH	na
155	UL	NIB	2010	MAYORA	na
156	UL	NIB	2010	METRO EKSPRESS	na
157	UL	NIB	2010	MIZUHO	na
158	UL	NIB	2010	MULTI ARTA SENTOSA (MAS)	na
159	UL	NIB	2010	PURBA DANARTA	na
160	UL	NIB	2010	ROYAL BANK SCOTLAND	na
161	UL	NIB	2010	ROYAL INDONESIA	na
162	UL	NIB	2010	SULAWESI TENGAH	na
163	UL	NIB	2010	SULAWESI TENGGARA	na
164	UL	NIB	2010	SUMATERA SELATAN	na
165	UL	NIB	2010	SUMITOMO MITSUI INDONESIA	na
166	UL	NIB	2010	TOKYO-MITSUBISHI LTD.	na
167	UL	NIB	2011	AGRIS	na
168	UL	NIB	2011	BANK OF AMERICA	na
169	UL	NIB	2011	BISNIS INTERNASIONAL	na
170	UL	I	2011	JABAR SYARIAH	na
171	UL	NIB	2011	JP MORGAN	na
172	UL	NIB	2011	LAMPUNG	na
173	UL	NIB	2011	LIMAN INTERNATIONAL BANK	na
174	UL	NIB	2011	METRO EKSPRESS	na
175	UL	NIB	2011	MIZUHO	na
176	UL	NIB	2011	ROYAL BANK SCOTLAND	na
177	UL	NIB	2011	SULAWESI TENGGARA	na
178	UL	NIB	2011	TOKYO-MITSUBISHI LTD.	na

NO.	LISTING	ISLAMIC	YEAR	BANK	NOTE
179	UL	NIB	2012	LAMPUNG	na
180	UL	NIB	2012	PURBA DANARTA	na
181	UL	NIB	2012	SULAWESI TENGAH	na
182	UL	NIB	2010	MESTIKA DHARMA	password
183	UL	NIB	2011	MESTIKA DHARMA	password
184	UL	NIB	2012	AGRIS	password
185	UL	NIB	2012	MASPION	password
186	UL	NIB	2012	MESTIKA DHARMA	password
187	UL	NIB	2012	MIZUHO	password

UL = Unlisted Banks

L = Listed Banks

I = Islamic Banks

NIB = Non-Islamic Banks

na = not available

APPENDIX F - NORMALITY TEST FOR ISLAMIC BANKS VARIABLES

One-Sample Kolmogorov-Smirnov Test

		ASSET	LDR	ROE	LEVERAGE	EARNINGSREIN	RISKDISC	FIRMVALUE
N		27	27	27	27	27	27	27
Normal	Mean	.3617	-.0022	.0071	.0341	.0775	.0158	.6407
Parameters ^{a,b}	Std. Deviation	.42021	.35821	.25444	.34344	.71969	.04784	1.87480
Most Extreme Differences	Absolute	.209	.235	.197	.238	.432	.201	.276
	Positive	.198	.235	.175	.238	.432	.201	.276
	Negative	-.209	-.136	-.197	-.165	-.383	-.184	-.273
Kolmogorov-Smirnov Z		1.088	1.223	1.022	1.235	2.244	1.046	1.435
Asymp. Sig. (2-tailed)		.187	.101	.247	.095	.000	.224	.033

a. Test distribution is Normal.

b. Calculated from data.

After Transforming

One-Sample Kolmogorov-Smirnov Test

		ASSET	LDR	ROE	LEVERAGE	RISKDISC	INV_FIRM	INV_EARN	log_earnings	log_firm	ln_firm
N		27	27	27	27	27	27	5	2	21	21
Normal	Mean	.3617	-.0022	.0071	.0341	.0158	5.3326	.2262	.6527	-.6297	-1.4499
Parameters ^{a,b}	Std. Deviation	.42021	.35821	.25444	.34344	.04784	23.92563	1.03657	.10926	.74061	1.70532
Most Extreme Differences	Absolute	.209	.235	.197	.238	.201	.229	.223	.260	.113	.113
	Positive	.198	.235	.175	.238	.201	.180	.201	.260	.113	.113
	Negative	-.209	-.136	-.197	-.165	-.184	-.229	-.223	-.260	-.113	-.113
Kolmogorov-Smirnov Z		1.088	1.223	1.022	1.235	1.046	1.192	.498	.368	.519	.519
Asymp. Sig. (2-tailed)		.187	.101	.247	.095	.224	.117	.965	.999	.950	.950

a. Test distribution is Normal.

b. Calculated from data.

APPENDIX G – RESULTS OF LAGGED

THE LAGGED OF THE ASSOCIATION BETWEEN THE DELTA OF FIRM CHARACTERISTICS AND THE DELTA OF RISK DISCLOSURE IN ALL BANKS

Model Summary^b

Model	R	R Square	Adjusted R Square	Std. Error of the Estimate	Durbin-Watson
1	.104 ^a	.011	-.015	.05884	2.267

a. Predictors: (Constant), earningsreinv, profitability, asset, liquidity, leverage

b. Dependent Variable: riskdisc

ANOVA^b

Model		Sum of Squares	df	Mean Square	F	Sig.
1	Regression	.007	5	.001	.412	.840 ^a
	Residual	.658	190	.003		
	Total	.665	195			

a. Predictors: (Constant), earningsreinv, profitability, asset, liquidity, leverage

b. Dependent Variable: riskdisc

Coefficients^a

Model		Unstandardized Coefficients		Standardized Coefficients	t	Sig.
		B	Std. Error	Beta		
1	(Constant)	.004	.005		.763	.447
	asset	.000	.003	-.013	-.175	.861
	liquidity	.003	.010	.023	.291	.771
	profitability	.000	.010	-.004	-.051	.959
	leverage	.008	.016	.039	.475	.635
	earningsreinv	.007	.007	.075	.971	.333

a. Dependent Variable: riskdisc

Residuals Statistics^a

	Minimum	Maximum	Mean	Std. Deviation	N
Predicted Value	-.0289	.0246	.0026	.00605	196
Residual	-.26569	.37823	.00000	.05808	196
Std. Predicted Value	-5.196	3.656	.000	1.000	196
Std. Residual	-4.516	6.428	.000	.987	196

a. Dependent Variable: riskdisc

APPENDIX H – THE RESULTS OF VALUE RELEVANT

THE VALUE RELEVANCE OF RISC DISLCOSURE IN ALL BANKS

Model Summary^b

Model	R	R Square	Adjusted R Square	Std. Error of the Estimate	Durbin-Watson
1	.583 ^a	.340	.331	258.60683	.601

a. Predictors: (Constant), EarningsR, RD, LDR, Leverage, ROE, assets

b. Dependent Variable: FV

ANOVA^b

Model		Sum of Squares	df	Mean Square	F	Sig.
1	Regression	1.401E7	6	2335738.199	34.926	.000 ^a
	Residual	2.715E7	406	66877.495		
	Total	4.117E7	412			

a. Predictors: (Constant), EarningsR, RD, LDR, Leverage, ROE, assets

b. Dependent Variable: FV

Coefficients^a

Model		Unstandardized Coefficients		Standardized Coefficients	t	Sig.
		B	Std. Error	Beta		
1	(Constant)	-99.141	58.587		-1.692	.091
	RD	-81.135	195.870	-.017	-.414	.679
	assets	-3.357	1.587	-.088	-2.115	.035
	LDR	25.890	22.975	.046	1.127	.260
	ROE	747.019	51.868	.590	14.402	.000
	Leverage	-47.008	51.323	-.038	-.916	.360
	EarningsR	46.711	28.071	.068	1.664	.097

a. Dependent Variable: FV

Residuals Statistics^a

	Minimum	Maximum	Mean	Std. Deviation	N
Predicted Value	-702.6340	2928.6548	31.3196	184.43320	413
Residual	-675.24432	2923.09912	.00000	256.71687	413
Std. Predicted Value	-3.980	15.709	.000	1.000	413
Std. Residual	-2.611	11.303	.000	.993	413

a. Dependent Variable: FV

THE VALUE RELEVANCE OF RISC DISLCOSURE IN LISTED BANKS

Model Summary^b

Model	R	R Square	Adjusted R Square	Std. Error of the Estimate	Durbin-Watson
1	.681 ^a	.464	.441	396.55985	.691

a. Predictors: (Constant), EarningsR, Leverage, LDR, ROE, RD, assets

b. Dependent Variable: FV

ANOVA^b

Model		Sum of Squares	df	Mean Square	F	Sig.
1	Regression	1.878E7	6	3130313.415	19.905	.000 ^a
	Residual	2.170E7	138	157259.715		
	Total	4.048E7	144			

a. Predictors: (Constant), EarningsR, Leverage, LDR, ROE, RD, assets

b. Dependent Variable: FV

Coefficients^a

Model		Unstandardized Coefficients		Standardized Coefficients	t	Sig.
		B	Std. Error	Beta		
1	(Constant)	-298.034	191.171		-1.559	.121
	RD	-266.155	482.567	-.036	-.552	.582
	assets	-5.554	2.813	-.132	-1.975	.050
	LDR	221.566	176.704	.079	1.254	.212
	ROE	981.644	90.999	.678	10.787	.000
	Leverage	21.655	96.643	.014	.224	.823
	EarningsR	102.826	110.210	.060	.933	.352

a. Dependent Variable: FV

Residuals Statistics^a

	Minimum	Maximum	Mean	Std. Deviation	N
Predicted Value	-904.9248	3942.2905	86.5659	361.15056	145
Residual	-679.88611	2780.86523	.00000	388.21029	145
Std. Predicted Value	-2.745	10.676	.000	1.000	145
Std. Residual	-1.714	7.012	.000	.979	145

a. Dependent Variable: FV

THE VALUE RELEVANCE OF RISC DISLCOSURE IN UNLISTED BANKS

Model Summary^b

Model	R	R Square	Adjusted R Square	Std. Error of the Estimate	Durbin-Watson
1	.831 ^a	.690	.683	1.07014	1.416

a. Predictors: (Constant), EarningsR, assets, LDR, RD, Leverage, ROE

b. Dependent Variable: FV

ANOVA^b

Model		Sum of Squares	df	Mean Square	F	Sig.
1	Regression	664.511	6	110.752	96.710	.000 ^a
	Residual	298.897	261	1.145		
	Total	963.408	267			

a. Predictors: (Constant), EarningsR, assets, LDR, RD, Leverage, ROE

b. Dependent Variable: FV

Coefficients^a

Model		Unstandardized Coefficients		Standardized Coefficients	t	Sig.
		B	Std. Error	Beta		
1	(Constant)	1.458	.414		3.520	.001
	RD	1.443	1.094	.047	1.320	.188
	assets	1.084	.046	.831	23.355	.000
	LDR	.149	.101	.052	1.473	.142
	ROE	.224	.451	.018	.497	.620
	Leverage	-1.720	.402	-.155	-4.274	.000
	EarningsR	-.174	.130	-.047	-1.337	.182

a. Dependent Variable: FV

Residuals Statistics^a

	Minimum	Maximum	Mean	Std. Deviation	N
Predicted Value	-.1189	8.0004	1.4289	1.57759	268
Residual	-3.57002	6.29452	.00000	1.05805	268
Std. Predicted Value	-.981	4.166	.000	1.000	268
Std. Residual	-3.336	5.882	.000	.989	268

a. Dependent Variable: FV

THE VALUE RELEVANCE OF RISC DISLCOSURE IN ISLAMIC BANKS

Model Summary^b

Model	R	R Square	Adjusted R Square	Std. Error of the Estimate	Durbin-Watson
1	.835 ^a	.697	.642	1.33337	2.640

a. Predictors: (Constant), EarningsR, LDR, ROE, Leverage, RD, assets

b. Dependent Variable: FV

ANOVA^b

Model		Sum of Squares	df	Mean Square	F	Sig.
1	Regression	134.955	6	22.492	12.651	.000 ^a
	Residual	58.670	33	1.778		
	Total	193.625	39			

a. Predictors: (Constant), EarningsR, LDR, ROE, Leverage, RD, assets

b. Dependent Variable: FV

Coefficients^a

Model		Unstandardized Coefficients		Standardized Coefficients	t	Sig.
		B	Std. Error	Beta		
1	(Constant)	.921	.983		.937	.356
	RD	1.766	4.182	.042	.422	.676
	assets	1.278	.171	.798	7.473	.000
	LDR	.278	.501	.054	.554	.583
	ROE	-.346	1.128	-.033	-.307	.761
	Leverage	-1.566	.786	-.201	-1.993	.055
	EarningsR	-.041	.375	-.011	-.110	.913

a. Dependent Variable: FV

Residuals Statistics^a

	Minimum	Maximum	Mean	Std. Deviation	N
Predicted Value	-.0579	8.1619	1.4437	1.86021	40
Residual	-2.98358	5.62814	.00000	1.22652	40
Std. Predicted Value	-.807	3.611	.000	1.000	40
Std. Residual	-2.238	4.221	.000	.920	40

a. Dependent Variable: FV

THE VALUE RELEVANCE OF RISC DISLCOSURE IN NON-ISLAMIC BANKS

Model Summary^b

Model	R	R Square	Adjusted R Square	Std. Error of the Estimate	Durbin-Watson
1	.605 ^a	.366	.356	266.85313	.594

a. Predictors: (Constant), EarningsR, assets, LDR, RD, ROE, Leverage

b. Dependent Variable: FV

ANOVA^b

Model		Sum of Squares	df	Mean Square	F	Sig.
1	Regression	1.506E7	6	2510648.212	35.257	.000 ^a
	Residual	2.606E7	366	71210.595		
	Total	4.113E7	372			

a. Predictors: (Constant), EarningsR, assets, LDR, RD, ROE, Leverage

b. Dependent Variable: FV

Coefficients^a

Model		Unstandardized Coefficients		Standardized Coefficients	t	Sig.
		B	Std. Error	Beta		
1	(Constant)	-110.428	64.445		-1.714	.087
	RD	-68.886	208.761	-.014	-.330	.742
	assets	-3.627	1.652	-.094	-2.195	.029
	LDR	27.868	24.407	.048	1.142	.254
	ROE	801.318	55.401	.612	14.464	.000
	Leverage	-51.154	56.696	-.038	-.902	.368
	EarningsR	57.182	31.584	.076	1.810	.071

a. Dependent Variable: FV

Residuals Statistics^a

	Minimum	Maximum	Mean	Std. Deviation	N
Predicted Value	-750.0580	3145.0002	34.5234	201.23202	373
Residual	-728.24091	2904.32764	.00000	264.69234	373
Std. Predicted Value	-3.899	15.457	.000	1.000	373
Std. Residual	-2.729	10.884	.000	.992	373

a. Dependent Variable: FV

APPENDIX I – THE RESULTS OF SPSS

THE DIFFERENCES BETWEEN LISTED AND UNLISTED BANKS GROUP STATISTICS

Group Statistics					
	STATUS	N	Mean	Std. Deviation	Std. Error Mean
ASSETS	1	196	.2292	.54297	.03878
	2	116	1.3751	2.04523	.18989
LDR	1	196	.1070	.49546	.03539
	2	116	.0010	.22247	.02066
ROE	1	196	.0197	.14439	.01031
	2	116	.0294	.56325	.05230
LEVERAGE	1	196	.0567	.26494	.01892
	2	116	-.2032	.39321	.03651
EARNINGREIV	1	196	.0851	.54528	.03895
	2	116	-.0148	.43726	.04060
RISKDISC	1	196	.0067	.06947	.00496
	2	116	.0045	.04749	.00441
FIRMVALUE	1	196	.3027	1.35563	.09683
	2	116	19.3341	441.28961	40.97271

THE DIFFERENCES BETWEEN ISLAMIC AND NON-ISLAMIC BANKS GROUP STATISTICS

Group Statistics					
	ISLAMIC	N	Mean	Std. Deviation	Std. Error Mean
ASSETS	5	285	.6830	1.48593	.08802
	6	27	.3617	.42021	.08087
LDR	5	285	.0742	.42334	.02508
	6	27	-.0022	.35821	.06894
ROE	5	285	.0249	.36993	.02191
	6	27	.0071	.25444	.04897
LEVERAGE	5	285	-.0470	.34171	.02024
	6	27	.0341	.34344	.06609
EARNINGREIV	5	285	.0451	.48644	.02881
	6	27	.0775	.71969	.13850
RISKDISC	5	285	.0049	.06331	.00375
	6	27	.0158	.04784	.00921
FIRMVALUE	5	285	8.0168	280.96926	16.64318
	6	27	.6407	1.87480	.36080

LEVENE'S TEST LISTED AND UNLISTED BANKS

Independent Samples Test										
		Levene's Test for Equality of Variances		t-test for Equality of Means					95% Confidence Interval of the Difference	
		F	Sig.	t	df	Sig. (2-tailed)	Mean Difference	Std. Error Difference	Lower	Upper
ASSETS	Equal variances assumed	128.775	.000	-7.421	310	.000	-1.14584	.15440	-1.44964	-.84203
	Equal variances not assumed			-5.912	124.666	.000	-1.14584	.19381	-1.52943	-.76224
LDR	Equal variances assumed	12.297	.001	2.176	310	.030	.10594	.04869	.01013	.20175
	Equal variances not assumed			2.585	292.859	.010	.10594	.04098	.02529	.18658
ROE	Equal variances assumed	3.453	.064	-.228	310	.820	-.00967	.04237	-.09303	.07370
	Equal variances not assumed			-.181	124.009	.856	-.00967	.05330	-.11517	.09584
LEVERAGE	Equal variances assumed	53.003	.000	6.963	310	.000	.25989	.03732	.18645	.33333
	Equal variances not assumed			6.320	177.544	.000	.25989	.04112	.17874	.34104
EARNINGREIV	Equal variances assumed	5.738	.017	1.679	310	.094	.09989	.05950	-.01718	.21696
	Equal variances not assumed			1.776	282.816	.077	.09989	.05626	-.01085	.21063
RISKDISC	Equal variances assumed	8.060	.005	.303	310	.762	.00221	.00729	-.01214	.01655
	Equal variances not assumed			.332	303.588	.740	.00221	.00664	-.01086	.01527
FIRMVALUE	Equal variances assumed	6.082	.014	-.604	310	.546	-19.03146	31.48586	-80.98448	42.92156
	Equal variances not assumed			-.464	115.001	.643	-19.03146	40.97283	-100.19074	62.12781

LEVENE'S TEST BETWEEN ISLAMIC AND NON-ISLAMIC BANKS

Independent Samples Test											
		Levene's Test for Equality of Variances		t-test for Equality of Means						95% Confidence Interval of the Difference	
		F	Sig.	t	df	Sig. (2- tailed)	Mean Difference	Std. Error Difference	Lower	Upper	
ASSETS	Equal variances assumed	6.583	.011	1.118	310	.264	.32135	.28743	-.24422	.88691	
	Equal variances not assumed			2.688	109.962	.008	.32135	.11953	.08447	.55822	
LDR	Equal variances assumed	.111	.740	.907	310	.365	.07639	.08422	-.08933	.24211	
	Equal variances not assumed			1.041	33.282	.305	.07639	.07336	-.07281	.22559	
ROE	Equal variances assumed	.988	.321	.243	310	.808	.01771	.07283	-.12559	.16100	
	Equal variances not assumed			.330	37.319	.743	.01771	.05365	-.09096	.12638	
LEVERAGE	Equal variances assumed	.177	.675	- 1.178	310	.240	-.08109	.06884	-.21653	.05435	
	Equal variances not assumed			- 1.173	31.081	.250	-.08109	.06912	-.22206	.05988	
EARNINGREIV	Equal variances assumed	1.903	.169	-.315	310	.753	-.03238	.10272	-.23449	.16973	
	Equal variances not assumed			-.229	28.294	.821	-.03238	.14147	-.32203	.25727	
RISKDISC	Equal variances assumed	.247	.620	-.869	310	.386	-.01088	.01252	-.03551	.01375	
	Equal variances not assumed			- 1.094	35.254	.281	-.01088	.00994	-.03105	.00930	
FIRMVALUE	Equal variances assumed	.322	.571	.136	310	.892	7.37611	54.15156	-99.17500	113.92721	
	Equal variances not assumed			.443	284.266	.658	7.37611	16.64709	-25.39110	40.14332	

PEARSON CORRELATION THE DELTA OF FIRM CHARACTERISTICS AND THE DELTA OF RISK DISCLOSURE IN ALL BANKS

Correlations								
		asset	ldr	roe	leverage	earnings	riskdis	firmvalue
asset	Pearson Correlation	1	.056	-.007	-.149**	.071	.045	-.010
	Sig. (1-tailed)		.160	.453	.004	.106	.215	.432
	N	312	312	312	312	312	312	312
ldr	Pearson Correlation	.056	1	.030	.260**	.155**	.120*	-.016
	Sig. (1-tailed)	.160		.297	.000	.003	.017	.389
	N	312	312	312	312	312	312	312
roe	Pearson Correlation	-.007	.030	1	.113*	.057	-.009	.842**
	Sig. (1-tailed)	.453	.297		.023	.157	.440	.000
	N	312	312	312	312	312	312	312
leverage	Pearson Correlation	-.149**	.260**	.113*	1	.157**	.088	.103*
	Sig. (1-tailed)	.004	.000	.023		.003	.061	.035
	N	312	312	312	312	312	312	312
earnings	Pearson Correlation	.071	.155**	.057	.157**	1	.020	-.002
	Sig. (1-tailed)	.106	.003	.157	.003		.361	.484
	N	312	312	312	312	312	312	312
riskdis	Pearson Correlation	.045	.120*	-.009	.088	.020	1	.022
	Sig. (1-tailed)	.215	.017	.440	.061	.361		.352
	N	312	312	312	312	312	312	312
firmvalue	Pearson Correlation	-.010	-.016	.842**	.103*	-.002	.022	1
	Sig. (1-tailed)	.432	.389	.000	.035	.484	.352	
	N	312	312	312	312	312	312	312
**. Correlation is significant at the 0.01 level (1-tailed).								
*. Correlation is significant at the 0.05 level (1-tailed).								

MULTIPLE REGRESSION OF THE DELTA OF FIRM CHARACTERISTIC AND THE DELTA OF RISK DISCLOSURE IN ALL BANKS

Model Summary^b

Model	R	R Square	Adjusted R Square	Std. Error of the Estimate	Durbin-Watson
1	.144 ^a	.021	.005	.06199	2.390

a. Predictors: (Constant), earnings, roe, asset, ldr, leverage

b. Dependent Variable: riskdis

ANOVA^b

Model		Sum of Squares	df	Mean Square	F	Sig.
1	Regression	.025	5	.005	1.289	.268 ^a
	Residual	1.176	306	.004		
	Total	1.201	311			

a. Predictors: (Constant), earnings, roe, asset, ldr, leverage

b. Dependent Variable: riskdis

Coefficients^a

Model		Unstandardized Coefficients		Standardized Coefficients	t	Sig.	Collinearity Statistics	
		B	Std. Error	Beta			Tolerance	VIF
1	(Constant)	.004	.004		1.035	.302		
	asset	.002	.003	.050	.875	.382	.961	1.041
	ldr	.015	.009	.100	1.693	.092	.912	1.097
	roe	-.003	.010	-.019	-.332	.740	.986	1.015
	leverage	.013	.011	.073	1.204	.229	.880	1.137
	earnings	-.001	.007	-.009	-.158	.874	.953	1.050

a. Dependent Variable: riskdis

Residuals Statistics^a

	Minimum	Maximum	Mean	Std. Deviation	N
Predicted Value	-.0189	.0654	.0058	.00893	312
Residual	-.33217	.37787	.00000	.06149	312
Std. Predicted Value	-2.773	6.673	.000	1.000	312
Std. Residual	-5.358	6.095	.000	.992	312

a. Dependent Variable: riskdis

PEARSON CORRELATION BETWEEN THE DELTA OF FIRM CHARACTERISTICS, THE DELTA OF RISK DISCLSOSURE AND THE DELTA OF FIRM VALUE IN ALL BANKS

Correlations								
		asset	ldr	roe	leverage	earnings	riskdis	firmvalue
asset	Pearson Correlation	1	.056	-.007	-.149**	.071	.045	-.010
	Sig. (1-tailed)		.160	.453	.004	.106	.215	.432
	N	312	312	312	312	312	312	312
ldr	Pearson Correlation	.056	1	.030	.260**	.155**	.120*	-.016
	Sig. (1-tailed)	.160		.297	.000	.003	.017	.389
	N	312	312	312	312	312	312	312
roe	Pearson Correlation	-.007	.030	1	.113*	.057	-.009	.842**
	Sig. (1-tailed)	.453	.297		.023	.157	.440	.000
	N	312	312	312	312	312	312	312
leverage	Pearson Correlation	-.149**	.260**	.113*	1	.157**	.088	.103*
	Sig. (1-tailed)	.004	.000	.023		.003	.061	.035
	N	312	312	312	312	312	312	312
earnings	Pearson Correlation	.071	.155**	.057	.157**	1	.020	-.002
	Sig. (1-tailed)	.106	.003	.157	.003		.361	.484
	N	312	312	312	312	312	312	312
riskdis	Pearson Correlation	.045	.120*	-.009	.088	.020	1	.022
	Sig. (1-tailed)	.215	.017	.440	.061	.361		.352
	N	312	312	312	312	312	312	312
firmvalue	Pearson Correlation	-.010	-.016	.842**	.103*	-.002	.022	1
	Sig. (1-tailed)	.432	.389	.000	.035	.484	.352	
	N	312	312	312	312	312	312	312
**. Correlation is significant at the 0.01 level (1-tailed).								
*. Correlation is significant at the 0.05 level (1-tailed).								

MULTIPLE REGRESSION OF FIRM VALUE IN ALL BANKS

Model Summary^b

Model	R	R Square	Adjusted R Square	Std. Error of the Estimate	Durbin-Watson
1	.845 ^a	.715	.709	144.79689	1.763

a. Predictors: (Constant), RISKDISC, ROE, ASSETS, EARNINGREIV, LDR, LEVERAGE

b. Dependent Variable: FIRMVALUE

ANOVA^b

Model		Sum of Squares	df	Mean Square	F	Sig.
1	Regression	1.603E7	6	2671129.876	127.402	.000 ^a
	Residual	6394672.677	305	20966.140		
	Total	2.242E7	311			

a. Predictors: (Constant), RISKDISC, ROE, ASSETS, EARNINGREIV, LDR, LEVERAGE

b. Dependent Variable: FIRMVALUE

Coefficients^a

Model		Unstandardized Coefficients		Standardized Coefficients	t	Sig.	Collinearity Statistics	
		B	Std. Error	Beta			Tolerance	VIF
1	(Constant)	-4.655	9.166		-.508	.612		
	ASSETS	.745	5.873	.004	.127	.899	.959	1.043
	LDR	-28.656	20.659	-.045	-1.387	.166	.903	1.107
	ROE	627.494	22.907	.844	27.393	.000	.985	1.015
	LEVERAGE	18.996	25.654	.024	.740	.460	.875	1.142
	EARNINGREIV	-25.481	16.514	-.048	-1.543	.124	.953	1.050
	RISKDISC	141.585	133.520	.033	1.060	.290	.979	1.021

a. Dependent Variable: FIRMVALUE

Residuals Statistics^a

	Minimum	Maximum	Mean	Std. Deviation	N
Predicted Value	-2282.9099	2868.4395	7.3785	227.00893	312
Residual	-586.68066	1621.90857	.00000	143.39333	312
Std. Predicted Value	-10.089	12.603	.000	1.000	312
Std. Residual	-4.052	11.201	.000	.990	312

a. Dependent Variable: FIRMVALUE

PEARSON CORRELATION BETWEEN THE DELTA OF FIRM CHARACTERISTICS, THE DELTA OF RISK DISCLSOSURE AND THE DELTA OF FIRM VALUE IN LISTED BANKS

Correlations								
		ASSET	LDR	ROE	LEVERAGE	EARNINGSRE	RISKDISC	FIRMVALUE
ASSET	Pearson Correlation	1	.092	-.013	-.074	.150	.086	-.027
	Sig. (1-tailed)		.163	.446	.215	.054	.179	.386
	N	116	116	116	116	116	116	116
LDR	Pearson Correlation	.092	1	-.040	-.075	-.169*	.082	-.039
	Sig. (1-tailed)	.163		.334	.211	.035	.191	.340
	N	116	116	116	116	116	116	116
ROE	Pearson Correlation	-.013	-.040	1	.111	-.018	.041	.888**
	Sig. (1-tailed)	.446	.334		.117	.426	.330	.000
	N	116	116	116	116	116	116	116
LEVERAGE	Pearson Correlation	-.074	-.075	.111	1	.000	-.100	.165*
	Sig. (1-tailed)	.215	.211	.117		.496	.142	.038
	N	116	116	116	116	116	116	116
EARNINGSRE	Pearson Correlation	.150	-.169*	-.018	.000	1	-.074	.001
	Sig. (1-tailed)	.054	.035	.426	.496		.215	.494
	N	116	116	116	116	116	116	116
RISKDISC	Pearson Correlation	.086	.082	.041	-.100	-.074	1	.047
	Sig. (1-tailed)	.179	.191	.330	.142	.215		.307
	N	116	116	116	116	116	116	116
FIRMVALUE	Pearson Correlation	-.027	-.039	.888**	.165*	.001	.047	1
	Sig. (1-tailed)	.386	.340	.000	.038	.494	.307	
	N	116	116	116	116	116	116	116
*. Correlation is significant at the 0.05 level (1-tailed).								
**. Correlation is significant at the 0.01 level (1-tailed).								

MULTIPLE REGRESSIONS OF THE DELTA OF FIRM CHARACTERISTICS AND THE DELTA OF RISK DISCLOSURE IN LISTED BANKS

Model Summary^b

Model	R	R Square	Adjusted R Square	Std. Error of the Estimate	Durbin-Watson
1	.172 ^a	.029	-.015	.04783	2.565

a. Predictors: (Constant), EARNINGSRE, LEVERAGE, ROE, ASSET, LDR

b. Dependent Variable: RISKDISC

ANOVA^b

Model		Sum of Squares	df	Mean Square	F	Sig.
1	Regression	.008	5	.002	.668	.648 ^a
	Residual	.252	110	.002		
	Total	.259	115			

a. Predictors: (Constant), EARNINGSRE, LEVERAGE, ROE, ASSET, LDR

b. Dependent Variable: RISKDISC

Coefficients^a

Model	Unstandardized Coefficients		Standardized Coefficients	t	Sig.	Collinearity Statistics	
	B	Std. Error	Beta			Tolerance	VIF
1 (Constant)	.000	.006		-.156	.876		
ASSET	.002	.002	.086	.898	.371	.959	1.043
LDR	.012	.021	.056	.582	.562	.952	1.051
ROE	.005	.008	.054	.570	.570	.986	1.014
LEVERAGE	-.012	.011	-.096	-1.007	.316	.978	1.022
EARNINGSRE	-.008	.011	-.076	-.791	.431	.943	1.060

a. Dependent Variable: RISKDISC

Residuals Statistics^a

	Minimum	Maximum	Mean	Std. Deviation	N
Predicted Value	-.0200	.0294	.0045	.00815	116
Residual	-.21119	.21153	.00000	.04678	116
Std. Predicted Value	-3.002	3.065	.000	1.000	116
Std. Residual	-4.415	4.422	.000	.978	116

a. Dependent Variable: RISKDISC

MULTIPLE REGRESSIONS FIRM CHARACTERISTICS AND RISK DISCLOSURE AND FIRM VALUE LISTED BANKS

Model Summary^b

Model	R	R Square	Adjusted R Square	Std. Error of the Estimate	Durbin-Watson
1	.891 ^a	.794	.783	205.72584	1.711

a. Predictors: (Constant), RISKDISC, ROE, EARNINGSRE, LEVERAGE, ASSET, LDR

b. Dependent Variable: FIRMVALUE

ANOVA^b

Model		Sum of Squares	df	Mean Square	F	Sig.
1	Regression	1.778E7	6	2963579.876	70.023	.000 ^a
	Residual	4613220.409	109	42323.123		
	Total	2.239E7	115			

a. Predictors: (Constant), RISKDISC, ROE, EARNINGSRE, LEVERAGE, ASSET, LDR

b. Dependent Variable: FIRMVALUE

Coefficients^a

Model		Unstandardized Coefficients		Standardized Coefficients	t	Sig.	Collinearity Statistics	
		B	Std. Error	Beta			Tolerance	VIF
1	(Constant)	19.017	25.052		.759	.449		
	ASSET	-3.577	9.612	-.017	-.372	.711	.952	1.050
	LDR	10.397	88.524	.005	.117	.907	.949	1.054
	ROE	689.457	34.350	.880	20.071	.000	.983	1.017
	LEVERAGE	76.562	49.558	.068	1.545	.125	.969	1.032
	EARNINGSRE	22.071	45.298	.022	.487	.627	.938	1.066
	RISKDISC	189.234	410.071	.020	.461	.645	.971	1.030

a. Dependent Variable: FIRMVALUE

Residuals Statistics^a

	Minimum	Maximum	Mean	Std. Deviation	N
Predicted Value	-2490.4106	3202.5220	19.3341	393.21948	116
Residual	-549.37335	1287.82593	.00000	200.28719	116
Std. Predicted Value	-6.383	8.095	.000	1.000	116
Std. Residual	-2.670	6.260	.000	.974	116

a. Dependent Variable: FIRMVALUE

PEARSON CORRELATION OF THE DELTA OF FIRM CHARACTERISTIC AND THE DELTA OF RISK DISCLOSURE IN UNLISTED BANKS

Correlations

		ASSET	LDR	ROE	LEVERAGE	EARNINGSRE	RISKDISC	FIRMVALUE
ASSET	Pearson Correlation	1	.277**	-.014	.211**	.156*	.062	.486**
	Sig. (1-tailed)		.000	.424	.002	.015	.193	.000
	N	196	196	196	196	196	196	196
LDR	Pearson Correlation	.277**	1	.149*	.403**	.216**	.127*	.186**
	Sig. (1-tailed)	.000		.019	.000	.001	.038	.004
	N	196	196	196	196	196	196	196
ROE	Pearson Correlation	-.014	.149*	1	.228**	.250**	-.094	.012
	Sig. (1-tailed)	.424	.019		.001	.000	.094	.432
	N	196	196	196	196	196	196	196
LEVERAGE	Pearson Correlation	.211**	.403**	.228**	1	.236**	.210**	.116
	Sig. (1-tailed)	.002	.000	.001		.000	.002	.053
	N	196	196	196	196	196	196	196
EARNINGSRE	Pearson Correlation	.156*	.216**	.250**	.236**	1	.049	.048
	Sig. (1-tailed)	.015	.001	.000	.000		.249	.254
	N	196	196	196	196	196	196	196
RISKDISC	Pearson Correlation	.062	.127*	-.094	.210**	.049	1	.056
	Sig. (1-tailed)	.193	.038	.094	.002	.249		.216
	N	196	196	196	196	196	196	196
FIRMVALUE	Pearson Correlation	.486**	.186**	.012	.116	.048	.056	1
	Sig. (1-tailed)	.000	.004	.432	.053	.254	.216	
	N	196	196	196	196	196	196	196

** . Correlation is significant at the 0.01 level (1-tailed).

* . Correlation is significant at the 0.05 level (1-tailed).

MULTIPLE REGRESSIONS OF THE DELTA OF FIRM CHARACTERISTICS AND THE DELTA OF RISK DISCLOSURE IN UNLISTED BANKS

Model Summary^b

Model	R	R Square	Adjusted R Square	Std. Error of the Estimate	Durbin-Watson
1	.263 ^a	.069	.044	.06791	2.324

a. Predictors: (Constant), EARNINGSRE, ASSET, ROE, LDR, LEVERAGE

b. Dependent Variable: RISKDISC

ANOVA^b

Model		Sum of Squares	df	Mean Square	F	Sig.
1	Regression	.065	5	.013	2.816	.018 ^a
	Residual	.876	190	.005		
	Total	.941	195			

a. Predictors: (Constant), EARNINGSRE, ASSET, ROE, LDR, LEVERAGE

b. Dependent Variable: RISKDISC

Coefficients^a

Model		Unstandardized Coefficients		Standardized Coefficients	t	Sig.	Collinearity Statistics	
		B	Std. Error	Beta			Tolerance	VIF
1	(Constant)	.004	.005		.742	.459		
	ASSET	.000	.009	-.006	-.085	.932	.896	1.116
	LDR	.008	.011	.060	.755	.451	.786	1.272
	ROE	-.077	.036	-.159	-2.155	.032	.897	1.115
	LEVERAGE	.057	.021	.217	2.750	.007	.785	1.273
	EARNINGSRE	.003	.010	.025	.341	.733	.880	1.136

a. Dependent Variable: RISKDISC

Residuals Statistics^a

	Minimum	Maximum	Mean	Std. Deviation	N
Predicted Value	-.0637	.0718	.0067	.01825	196
Residual	-.33053	.38072	.00000	.06703	196
Std. Predicted Value	-3.855	3.567	.000	1.000	196
Std. Residual	-4.867	5.606	.000	.987	196

a. Dependent Variable: RISKDISC

MULTIPLE REGRESSIONS OF THE DELTA OF FIRM CHARACTERISTICS AND THE DELTA OF RISK DISCLOSURE AND THE DELTA OF FIRM VALUE IN UNLISTED BANKS

Model Summary^b

Model	R	R Square	Adjusted R Square	Std. Error of the Estimate	Durbin-Watson
1	.492 ^a	.242	.218	1.19882	2.456

a. Predictors: (Constant), RISKDISC, EARNINGRE, ASSET, ROE, LDR, LEVERAGE

b. Dependent Variable: FIRMVALUE

ANOVA^b

Model		Sum of Squares	df	Mean Square	F	Sig.
1	Regression	86.729	6	14.455	10.058	.000 ^a
	Residual	271.626	189	1.437		
	Total	358.355	195			

a. Predictors: (Constant), RISKDISC, EARNINGRE, ASSET, ROE, LDR, LEVERAGE

b. Dependent Variable: FIRMVALUE

Coefficients^a

Model		Unstandardized Coefficients		Standardized Coefficients	t	Sig.	Collinearity Statistics	
		B	Std. Error	Beta			Tolerance	VIF
1	(Constant)	.016	.094		.169	.866		
	ASSET	1.192	.167	.477	7.136	.000	.896	1.116
	LDR	.167	.196	.061	.852	.395	.784	1.276
	ROE	.242	.635	.026	.382	.703	.876	1.142
	LEVERAGE	-.052	.373	-.010	-.139	.890	.755	1.324
	EARNINGRE	-.112	.168	-.045	-.670	.504	.879	1.137
	RISKDISC	.504	1.281	.026	.393	.694	.931	1.074

a. Dependent Variable: FIRMVALUE

Residuals Statistics^a

	Minimum	Maximum	Mean	Std. Deviation	N
Predicted Value	-1.0622	7.7155	.3027	.66691	196
Residual	-5.64420	8.84243	.00000	1.18024	196
Std. Predicted Value	-2.047	11.115	.000	1.000	196
Std. Residual	-4.708	7.376	.000	.984	196

a. Dependent Variable: FIRMVALUE

PEARSON CORRELATION OF THE DELTA OF FIRM CHARACTERISTIC AND THE DELTA OF RISK DISCLOSURE IN ISLAMIC BANKS

Correlations							
		ASSET	LDR	ROE	LEVERAGE	RISKDISC	FIRMVALUE
ASSET	Pearson Correlation	1	.051	-.145	-.323	-.282	.210
	Sig. (1-tailed)		.400	.235	.050	.077	.147
	N	27	27	27	27	27	27
LDR	Pearson Correlation	.051	1	.228	-.126	-.314	.117
	Sig. (1-tailed)	.400		.126	.265	.055	.280
	N	27	27	27	27	27	27
ROE	Pearson Correlation	-.145	.228	1	.122	-.180	-.049
	Sig. (1-tailed)	.235	.126		.272	.185	.405
	N	27	27	27	27	27	27
LEVERAGE	Pearson Correlation	-.323	-.126	.122	1	.113	-.050
	Sig. (1-tailed)	.050	.265	.272		.287	.402
	N	27	27	27	27	27	27
RISKDISC	Pearson Correlation	-.282	-.314	-.180	.113	1	-.094
	Sig. (1-tailed)	.077	.055	.185	.287		.321
	N	27	27	27	27	27	27
FIRMVALUE	Pearson Correlation	.210	.117	-.049	-.050	-.094	1
	Sig. (1-tailed)	.147	.280	.405	.402	.321	
	N	27	27	27	27	27	27

Correlations							
		ASSET	LDR	ROE	LEVERAGE	RISKDISC	ln_firm
ASSET	Pearson Correlation	1	.051	-.145	-.323	-.282	.480*
	Sig. (2-tailed)		.800	.469	.100	.154	.028
	N	27	27	27	27	27	21
LDR	Pearson Correlation	.051	1	.228	-.126	-.314	.171
	Sig. (2-tailed)	.800		.252	.530	.111	.458
	N	27	27	27	27	27	21
ROE	Pearson Correlation	-.145	.228	1	.122	-.180	.050
	Sig. (2-tailed)	.469	.252		.545	.369	.829
	N	27	27	27	27	27	21
LEVERAGE	Pearson Correlation	-.323	-.126	.122	1	.113	.119
	Sig. (2-tailed)	.100	.530	.545		.574	.607
	N	27	27	27	27	27	21
RISKDISC	Pearson Correlation	-.282	-.314	-.180	.113	1	-.469*
	Sig. (2-tailed)	.154	.111	.369	.574		.032
	N	27	27	27	27	27	21
ln_firm	Pearson Correlation	.480*	.171	.050	.119	-.469*	1
	Sig. (2-tailed)	.028	.458	.829	.607	.032	
	N	21	21	21	21	21	21

*. Correlation is significant at the 0.05 level (2-tailed).

MULTIPLE REGRESSIONS OF THE DELTA OF FIRM CHARACTERISTICS AND THE DELTA OF RISK DISCLOSURE IN ISLAMIC BANKS

Model Summary^b

Model	R	R Square	Adjusted R Square	Std. Error of the Estimate	Durbin-Watson
1	.440 ^a	.194	.047	.04670	1.756

a. Predictors: (Constant), LEVERAGE, ROE, LDR, ASSET

b. Dependent Variable: RISKDISC

ANOVA^b

Model		Sum of Squares	df	Mean Square	F	Sig.
1	Regression	.012	4	.003	1.323	.293 ^a
	Residual	.048	22	.002		
	Total	.060	26			

a. Predictors: (Constant), LEVERAGE, ROE, LDR, ASSET

b. Dependent Variable: RISKDISC

Coefficients^a

Model		Unstandardized Coefficients		Standardized Coefficients	t	Sig.
		B	Std. Error	Beta		
1	(Constant)	.028	.013		2.218	.037
	ASSET	-.033	.023	-.290	-1.426	.168
	LDR	-.035	.027	-.261	-1.309	.204
	ROE	-.031	.038	-.163	-.814	.424
	LEVERAGE	.001	.029	.006	.031	.976

a. Dependent Variable: RISKDISC

Residuals Statistics^a

	Minimum	Maximum	Mean	Std. Deviation	N
Predicted Value	-.0191	.0586	.0158	.02107	27
Residual	-.06711	.10980	.00000	.04295	27
Std. Predicted Value	-1.654	2.032	.000	1.000	27
Std. Residual	-1.437	2.351	.000	.920	27

a. Dependent Variable: RISKDISC

MULTIPLE REGRESSIONS OF THE DELTA OF FIRM CHARACTERISTICS AND THE DELTA OF RISK DISCLOSURE AND THE DELTA OF FIRM VALUE IN ISLAMIC BANKS

Model Summary^b

Model	R	R Square	Adjusted R Square	Std. Error of the Estimate	Durbin-Watson
1	.671 ^a	.450	.267	1.46000	2.318

a. Predictors: (Constant), RISKDISC, LEVERAGE, LDR, ROE, ASSET

b. Dependent Variable: In_firm

ANOVA^b

Model		Sum of Squares	df	Mean Square	F	Sig.
1	Regression	26.188	5	5.238	2.457	.081 ^a
	Residual	31.974	15	2.132		
	Total	58.162	20			

a. Predictors: (Constant), RISKDISC, LEVERAGE, LDR, ROE, ASSET

b. Dependent Variable: In_firm

Coefficients^a

Model		Unstandardized Coefficients		Standardized Coefficients	t	Sig.	Collinearity Statistics	
		B	Std. Error	Beta			Tolerance	VIF
1	(Constant)	-2.221	.570		-3.895	.001		
	LDR	.125	.892	.028	.141	.890	.900	1.111
	ROE	-.266	1.257	-.043	-.211	.835	.880	1.137
	ASSET	2.329	.980	.589	2.377	.031	.596	1.677
	LEVERAGE	2.313	1.244	.434	1.860	.083	.674	1.484
	RISKDISC	-8.175	7.498	-.241	-1.090	.293	.751	1.331

a. Dependent Variable: In_firm

Residuals Statistics^a

	Minimum	Maximum	Mean	Std. Deviation	N
Predicted Value	-3.4515	.8404	-1.4499	1.14429	21
Residual	-2.03467	3.46688	.00000	1.26440	21
Std. Predicted Value	-1.749	2.002	.000	1.000	21
Std. Residual	-1.394	2.375	.000	.866	21

a. Dependent Variable: In_firm

PEARSON CORRELATION OF THE DELTA OF FIRM CHARACTERISTIC AND THE DELTA OF RISK DISCLOSURE IN NON-ISLAMIC BANKS

		Correlations						
		ASSET	LDR	ROE	LEVERAGE	EARNINGS	RISKDISC	FIRMVALUE
ASSET	Pearson Correlation	1	.054	-.005	-.144**	.071	.055	-.010
	Sig. (1-tailed)		.181	.465	.007	.118	.177	.431
	N	285	285	285	285	285	285	285
LDR	Pearson Correlation	.054	1	.019	.295**	.179**	.148**	-.017
	Sig. (1-tailed)	.181		.374	.000	.001	.006	.387
	N	285	285	285	285	285	285	285
ROE	Pearson Correlation	-.005	.019	1	.115*	.044	.000	.860**
	Sig. (1-tailed)	.465	.374		.027	.230	.498	.000
	N	285	285	285	285	285	285	285
LEVERAGE	Pearson Correlation	-.144**	.295**	.115*	1	.157**	.083	.108*
	Sig. (1-tailed)	.007	.000	.027		.004	.082	.034
	N	285	285	285	285	285	285	285
EARNINGS	Pearson Correlation	.071	.179**	.044	.157**	1	.031	-.002
	Sig. (1-tailed)	.118	.001	.230	.004		.303	.484
	N	285	285	285	285	285	285	285
RISKDISC	Pearson Correlation	.055	.148**	.000	.083	.031	1	.023
	Sig. (1-tailed)	.177	.006	.498	.082	.303		.352
	N	285	285	285	285	285	285	285
FIRMVALUE	Pearson Correlation	-.010	-.017	.860**	.108*	-.002	.023	1
	Sig. (1-tailed)	.431	.387	.000	.034	.484	.352	
	N	285	285	285	285	285	285	285
**. Correlation is significant at the 0.01 level (1-tailed).								
*. Correlation is significant at the 0.05 level (1-tailed).								

MULTIPLE REGRESSIONS OF THE DELTA OF FIRM CHARACTERISTICS AND THE DELTA OF RISK DISCLOSURE IN NON-ISLAMIC BANKS

Model Summary^b

Model	R	R Square	Adjusted R Square	Std. Error of the Estimate	Durbin-Watson
1	.164 ^a	.027	.009	.06302	2.404

a. Predictors: (Constant), EARNINGS, ROE, ASSET, LDR, LEVERAGE

b. Dependent Variable: RISKDISC

ANOVA^b

Model		Sum of Squares	df	Mean Square	F	Sig.
1	Regression	.030	5	.006	1.535	.179 ^a
	Residual	1.108	279	.004		
	Total	1.138	284			

a. Predictors: (Constant), EARNINGS, ROE, ASSET, LDR, LEVERAGE

b. Dependent Variable: RISKDISC

Coefficients^a

Model		Unstandardized Coefficients		Standardized Coefficients	t	Sig.	Collinearity Statistics	
		B	Std. Error	Beta			Tolerance	VIF
1	(Constant)	.002	.004		.562	.574		
	ASSET	.002	.003	.056	.931	.353	.962	1.039
	LDR	.020	.009	.130	2.081	.038	.887	1.127
	ROE	-.001	.010	-.008	-.132	.895	.986	1.015
	LEVERAGE	.010	.012	.054	.851	.396	.863	1.158
	EARNINGS	.000	.008	-.005	-.079	.937	.949	1.054

a. Dependent Variable: RISKDISC

Residuals Statistics^a

	Minimum	Maximum	Mean	Std. Deviation	N
Predicted Value	-.0277	.0742	.0049	.01036	285
Residual	-.33061	.37902	.00000	.06246	285
Std. Predicted Value	-3.145	6.684	.000	1.000	285
Std. Residual	-5.246	6.015	.000	.991	285

a. Dependent Variable: RISKDISC

MULTIPLE REGRESSIONS OF THE DELTA OF FIRM CHARACTERISTICS AND THE DELTA OF RISK DISCLOSURE AND THE DELTA OF FIRM VALUE NON-ISLAMIC BANKS

Model Summary^b

Model	R	R Square	Adjusted R Square	Std. Error of the Estimate	Durbin-Watson
1	.862 ^a	.744	.738	143.73984	1.681

a. Predictors: (Constant), RISKDISC, ROE, EARNINGSRE, ASSET, LDR, LEVERAGE

b. Dependent Variable: FIRMVALUE

ANOVA^b

Model		Sum of Squares	df	Mean Square	F	Sig.
1	Regression	1.668E7	6	2779370.238	134.522	.000 ^a
	Residual	5743797.253	278	20661.141		
	Total	2.242E7	284			

a. Predictors: (Constant), RISKDISC, ROE, EARNINGSRE, ASSET, LDR, LEVERAGE

b. Dependent Variable: FIRMVALUE

Coefficients^a

Model		Unstandardized Coefficients		Standardized Coefficients	t	Sig.	Collinearity Statistics	
		B	Std. Error	Beta			Tolerance	VIF
1	(Constant)	-5.088	9.560		-.532	.595		
	ASSET	.187	5.860	.001	.032	.975	.959	1.042
	LDR	-25.318	21.553	-.038	-1.175	.241	.874	1.144
	ROE	653.070	23.224	.860	28.121	.000	.986	1.015
	LEVERAGE	20.620	26.901	.025	.767	.444	.861	1.161
	EARNINGSRE	-22.038	18.002	-.038	-1.224	.222	.949	1.054
	RISKDISC	119.699	136.560	.027	.877	.382	.973	1.028

a. Dependent Variable: FIRMVALUE

Residuals Statistics^a

	Minimum	Maximum	Mean	Std. Deviation	N
Predicted Value	-2376.4888	2984.2095	8.0168	242.32022	285
Residual	-617.47235	1506.13855	.00000	142.21335	285
Std. Predicted Value	-9.840	12.282	.000	1.000	285
Std. Residual	-4.296	10.478	.000	.989	285

a. Dependent Variable: FIRMVALUE