

On the Assessment of Situational Intrinsic and Extrinsic Motivation: The Situational Motivation Scale (SIMS)

Frédéric Guay

Université Laval, Québec, Canada

Robert J. Vallerand

Université de Montréal, Montréal, Canada

Céline Blanchard

University of Ottawa, Ottawa, Canada

Abstract

The purpose of the present research was to develop and validate a situational (or state) measure of motivation, the Situational Motivation Scale (SIMS). The SIMS is designed to assess the constructs of intrinsic motivation, identified regulation, external regulation, and amotivation (E. L. Deci & R. M. Ryan, 1985, 1991) in field and laboratory settings. Five studies were conducted to develop and validate the SIMS. Overall, results show that the SIMS is composed of 4 internally consistent factors. The construct validity of the scale is also supported by correlations with other constructs as postulated by current theories. Moreover, the SIMS is responsive to experimental induction as evidenced by data gathered through a laboratory study. In sum, the SIMS represents a brief and versatile self-report measure of situational intrinsic motivation, identified regulation, external regulation, and amotivation.

Over the past two decades, more than 800 publications have explored the intrinsic–extrinsic motivation dichotomy (Vallerand, 1997). Intrinsic motivation refers to performing an activity for itself, in order to experience pleasure and satisfaction inherent in the activity. On the other hand, extrinsic motivation pertains to a wide variety of behaviors where the goals of action extend beyond those inherent in the activity itself (Deci & Ryan, 1985). A review of the literature (Vallerand, 1997) reveals that a large portion of this research deals with studies that have been conducted on situational motivation. *Situational motivation* refers to the motivation individuals experience when they are currently engaging in an activity. It refers to the here-and-now of motivation (Vallerand, 1997). For example, Deci's (Deci, 1971) laboratory study showed that leading individuals to engage in an interesting activity in order to receive a monetary reward led to a decrease in subsequent situational intrinsic motivation toward the activity. Since Deci's study, much laboratory research has revealed that external events such as competition (Reeve & Deci, 1996), deadlines (Amabile, Dejong, & Lepper, 1976), and limits (Koestner, Ryan, Bernieri, & Holt, 1984) can alter one's situational intrinsic motivation for a specific activity. Moreover, much research has shown that one's current motivation is related to psychological outcomes such as positive affect and vitality (e.g., Sheldon, Ryan, & Reis, 1996). Thus, situational (or state) motivation, as measured at a given point in time, provides a useful understanding of a person's current (or state) self-regulatory processes.

The purpose of this article is to present the development and validation of a new measure of situational intrinsic and extrinsic motivation, namely the Situational Motivation Scale (SIMS). We feel that this scale is needed because traditional measures of situational motivation such as the free-choice measure and self-report scales present some limitations. As we shall see, this paper also contributes to theory and research. Later on, we provide a brief presentation of self-determination theory (Deci & Ryan, 1985), which has provided the theoretical basis underlying the development of the SIMS. Then, we present a brief overview of traditional measures of situational motivation.

SELF-DETERMINATION THEORY

According to self-determination theory (Deci & Ryan, 1985), different types of motivation underlie human behavior. These types of motivation are posited to differ in their inherent levels of self-determination. Self-determination involves a true sense of choice, a sense of feeling free in doing what one has chosen to do. Listed on a continuum from high to low levels of self-determination, these motivations are intrinsic motivation, extrinsic motivation, and amotivation. As pointed out previously, *intrinsically motivated* behaviors are those that are engaged in for their own sake, in other words, for the pleasure and satisfaction derived from performing them (Deci, 1971).

On the other hand, extrinsic motivation pertains to a wide variety of behaviors where the goals of action extend beyond those inherent in the activity itself. Different types of extrinsic motivations have been proposed by self-determination theory that can also be ordered along the self-determination continuum. From lower to higher levels of self-determination, these are external and identified regulations.¹ *External regulation* occurs when behavior is regulated by rewards or in order to avoid negative consequences. That is, regardless of whether the goal of behavior is to obtain rewards or to avoid sanctions, the individual experiences an obligation to behave in a specific way. In contrast, *identified regulation* occurs when a behavior is valued and perceived as being chosen by oneself. Yet, the motivation is still extrinsic because the activity is not performed for itself but as a means to an end.

Besides intrinsic and extrinsic motivation, Deci and Ryan (1985) have proposed a third motivational concept namely, *amotivation*, to fully understand human behavior. When amotivated, individuals experience a lack of contingency between their behaviors and outcomes. Their behaviors are neither intrinsically nor extrinsically motivated. Amotivated behaviors are the least self-determined because there is no sense of purpose and no expectations of reward or possibility of changing the course of events. Amotivation can thus be seen as similar to learned helplessness (Abramson, Seligman, & Teasdale, 1978) where the individual experiences feelings of incompetence and expectancies of uncontrollability.

¹ In addition to identified and external regulations, self-determination theory postulates integrated and introjected regulations. *Integrated regulation* occurs when one comes to experience an organization among regulatory processes within which they can harmoniously coexist. More precisely, various identifications would not remain isolated but rather would operate harmoniously. This would be accompanied by a feeling of integrity and true sense of self. In contrast, *introjected regulation* occurs when one performs the activity by internal pressure such as guilt and self-approval. These two types of extrinsic motivation were not included in the scale development because their inclusion would result in a too long questionnaire. That is, the SIMS is designed to be used in various life settings it thus needs to be a versatile and brief measure of ongoing self-regulatory processes.

According to self-determination theory, these four types of motivation are differently related to various types of outcomes. Indeed, because these motivations differ in their inherent levels of self-determination and that self-determination has been hypothesized to be associated with enhanced psychological functioning (Deci & Ryan, 1985; Ryan, Deci, & Grolnick, 1995), one would expect intrinsic motivation to be mostly associated with positive outcomes (e.g., persistence) followed by identified regulation. In contrast, the most negative outcomes (e.g., depressive states) will stem from amotivation followed by external regulation. These findings have been obtained with several outcomes in various life contexts (see Deci & Ryan, 1985; Vallerand, 1997 for a review).

In addition, self-determination theory postulates that the needs for competence, autonomy, and relatedness are central concepts to understand the initiation and regulation of behavior. *Competence* implies a need for having an effect, for being effective in one's interactions with the environment. The need for *autonomy* is defined as a sense of feeling free from pressures and to have the possibility to make choices among several courses of action. Lastly, *relatedness* refers to interpersonal attachments and bonds developed between individuals, and is based on a fundamental striving for contact with others.

Self-determination theory also analyzes the effects of social factors in terms of their meaning for a person's feelings of competence, autonomy, and relatedness. That is, a social context that offers people the possibility to satisfy their basic needs will lead to self-determined types of motivation (i.e., intrinsic motivation and identified regulation) whereas events that thwart these needs will produce non-self-determined types of motivation (i.e., external regulation and amotivation). For instance, some studies have shown that negative feedback is associated with a decrease in perceptions of competence and intrinsic motivation (Vallerand & Reid, 1988). Moreover, a plethora of studies have shown that providing choice (i.e., autonomy support) is associated with feelings of autonomy and self-determined types of motivation (see Deci & Ryan, 1985; Vallerand, 1997 for a review). Finally, the work by Richer, Blanchard, and Vallerand (1998) has demonstrated that feelings of relatedness in the work place are related to self-determined work motivation. In sum, self-determination theory considers that needs for competence, autonomy, and relatedness should be fostered by the social context in order to produce self-determined motivations.

TRADITIONAL MEASURES OF SITUATIONAL MOTIVATION

Situational measures of motivation were developed to assess participants' immediate or current reactions toward a specific activity in which they were engaged. For two decades, two types of measures have been used: behavioral and self-report indices.

The Behavioral Measure of Intrinsic Motivation

The behavioral measure, namely the free-choice measure, has been extensively used in laboratory research in psychology (e.g., Deci, 1971; Ryan, Mims, & Koestner, 1983). For instance, a metaanalysis conducted by Cameron and Pierce (1994) on the effects of rewards on intrinsic motivation, revealed that above 64% of the studies have employed this measure. The free-choice measure consists of calculating the time spent on the activity when external contingencies are no

longer operative. More precisely, the experimenter declares that the experiment is officially over and presents a pretext for leaving the participant alone for a period of time (typically 8 minutes). During that period, the participant is surreptitiously observed through a one-way mirror. The participant then has the opportunity to work on the experimental task, to read some magazines, or to do something else. The rationale underlying the free-choice measure is that the more an individual persists at the experimental activity, the more he or she should be intrinsically motivated (Deci, 1971). This operationalization of the measure is in line with the usual definition of intrinsic motivation, which states that intrinsically motivated behavior typically occurs in the absence of any apparent external rewards (Deci & Ryan, 1985).

The construct validity of the free-choice measure has been supported through results in line with hypotheses derived from self-determination theory. For instance, some studies have revealed that ego-involvement (Ryan, 1982), deadlines (Amabile et al., 1976), and rewards (Ryan et al., 1983) lead to less time spent on the task (and thus less intrinsic motivation) than control conditions do. In terms of reliability, a study by Diblasio, Chantal, Vallerand, and Provencher (1995) has revealed an interrater reliability coefficient of .99. Although this measure is useful for laboratory research it nevertheless has two important limitations. First, this measure is unidimensional and consequently cannot assess other important motivational concepts derived from self-determination theory, namely identified regulation, external regulation, and amotivation. Second, the free-choice measure can hardly be used in field settings. This seriously limits the type of research that can be conducted with this measure.

Self-Report Measures of Intrinsic Motivation

In addition to the free-choice measure, self-report measures have also been used to assess intrinsic motivation at the situational level. A review of the literature reveals that two main scales were developed and validated: The Mayo Task Reaction Questionnaire (TRQ; Mayo, 1977) and the Intrinsic Motivation Inventory (IMI; McAuley, Duncan, & Tammen, 1989). We will also briefly discuss a third one that has been developed by Conti, Amabile, and Pollack (1995).

The TRQ is formed of 23 items assessing different aspects of intrinsic motivation (i.e., concentration, interest/enjoyment, achievement, challenge, competence, and autonomy), which are rated on a 7-point Likert scale. Although the scale measures many conceptual aspects of intrinsic motivation (e.g., challenge, enjoyment, etc.), the TRQ has been constructed in a way to capture overall intrinsic motivation (i.e., the scale is unidimensional). The psychometric properties of the TRQ have been supported in some studies. For example, Mayo (1977) as well as Pretty and Seligman (1984) have respectively reported internal consistency values of .93 and .95. Moreover, Fischer (1978) has obtained a split-half reliability of .96. Evidence for the construct validity of the TRQ has emerged in line with predictions stemming from self-determination theory. For example, employing the TRQ, Vallerand and Reid (1984) have shown that positive performance feedback increased intrinsic motivation, whereas negative feedback decreased it.

It should be noted that although the TRQ has some interesting psychometric properties, there are some problems with this measure. First, the scale is relatively long (23 items) for a situational measure. Second, no evidence has been reported on the factor structure of the scale. It is thus difficult to determine if the TRQ is unidimensional or multidimensional. Third, the TRQ does not

assess different types of motivation postulated by self-determination theory, namely identified regulation, external regulation, and amotivation. Finally, as pointed out by Vallerand and Fortier (1998), the TRQ includes items that refer to some determinants (e.g., perceived competence) and consequences of intrinsic motivation (e.g., concentration). Inferring motivation from motivational determinants and consequences seriously compromises the construct validity of the scale. As Deci (1987) warned, it is important to study intrinsic motivation in ways to keep clear the differences between needs (i.e., competence, autonomy, and relatedness) and responses that characterize intrinsic motivation. Hence, it seems critical that a self-report measure of motivation does not assess determinants and consequences of intrinsic motivation (see also Markland & Hardy, 1997 on this issue).

The Intrinsic Motivation Inventory (IMI; McAuley et al., 1989) represents another self-report instrument that was developed to assess situational intrinsic motivation. This scale was designed to assess four underlying dimensions of intrinsic motivation in a specific situation, namely interest-enjoyment, perceived competence, effort-importance, and pressure-tension. Studies have revealed high level of internal consistency for the subscales (see Duda, Chi, Newton, Walling, & Catley, 1995; McAuley et al., 1989; Seifriz, Duda, & Chi, 1992). Moreover, the construct validity of the scale has been supported by results in line with existing theories (Duda et al., 1995; McAuley & Tammen, 1989). However, data on the factorial validity of the IMI are much less impressive. Although the instrument has been tested through a confirmatory factor analysis, the Goodness of fit index (GFI) was .80, which is below the cut off value of .90 suggested by Bentler (1993). In addition, the IMI displays some of the limitations found with the TRQ. More specifically, the instrument does not assess other forms of motivation besides intrinsic motivation. Further, it also evaluates determinants (e.g., perceived competence) and consequences of intrinsic motivation (e.g., effort) rather than motivation per se.

To the best of our knowledge, only one scale has been developed to assess intrinsic and extrinsic motivation in a multidimensional fashion at the situational level. Conti et al. (1995) have developed a scale that measures two types of intrinsic motivation: (1) interest, (2) willingness to partake in future activities like the experimental task for intrinsic reasons; and three types of extrinsic motivation: (1) concern with the performance, (2) pressure and tension, and (3) concern with the experimenter's opinion. However, these subscales have not been fully validated and have low levels of internal consistency. The authors themselves concluded: "Because of the limited reliability of several of these scales, results of analyses on these variables must be interpreted with caution" (p. 1112).

In sum, although some of these traditional measures of situational motivation have provided results in line with hypotheses derived from existing theories, none of them assesses the types of extrinsic motivation proposed by Deci and Ryan (1985) as well as amotivation. Furthermore, the free-choice measure is difficult to use in field studies. The purpose of the present five studies was to develop and validate a measure of situational motivation that overcomes the limitations of the free-choice measure and self-report questionnaires. This measure is designed to assess a more diverse range of the types of motivation postulated by self-determination theory, namely intrinsic motivation, identified regulation, external regulation, and amotivation. This measure would thus represent a multidimensional measure of ongoing self-regulatory processes that could be used in laboratory and field settings. This instrument would also offer the possibility to address questions

that are related to other types of regulation (i.e., identified regulation and external regulation) than intrinsic motivation would.

STUDY 1: DEVELOPMENT AND VALIDATION

Study 1 comprised three goals. The first goal was to develop items assessing intrinsic motivation, identified regulation, external regulation, and amotivation. The second goal was to verify the four-factor structure of the SIMS, using exploratory factor analysis, as well as to assess the reliability of the subscales. The third goal consisted in examining the construct validity of the SIMS. Evidences of the construct validity would be offered by a simplex-like pattern of correlations among the four subscales. This pattern is based on the self-determination continuum described previously. More precisely, the interrelations among subscales were expected to form an ordered pattern in which those subscales adjacent along the self-determination continuum were expected to correlate more positively than those more distant along the continuum. In addition, the construct validity of the scale was assessed through correlations between the SIMS subscales and motivational determinants (i.e., perceived competence) and consequences (i.e., concentration and behavioral intentions). That is, intrinsic motivation and identified regulation were predicted to correlate positively with determinants and consequences of motivation whereas external regulation and amotivation were expected to correlate negatively with determinants and consequences. Furthermore, construct validity was evaluated by conducting correlations between the SIMS subscales and the Academic Motivation Scale (AMS; Vallerand, Blais, Brière, & Pelletier, 1989). More specifically, because the AMS assesses a motivational orientation in the school context and the SIMS was completed toward school activities, positive and specific interrelations should be observed between subscales of these two instruments as proposed by Vallerand's (Vallerand, 1997) hierarchical model of intrinsic and extrinsic motivation.

Method

Scale Development

Items were developed by a committee of experts (i.e., graduate students and professors). They were asked to generate items in line with the conceptual definition of intrinsic motivation, identified regulation, external regulation, and amotivation and to word them so as to indicate the underlying reasons for participating in an activity. This formulation is in line with the conceptual definition of motivation (Deci & Ryan, 1985; McClelland, 1985) which focuses on the “why of behavior.” Thus, with respect to the SIMS, respondents are asked the following question: “Why are you currently engaged in this activity?” Items represent potential answers to this question. In addition, the committee of experts was asked to word items such that they could be used toward field and laboratory activities. Fifty items were thus generated in order to assess the four motivational constructs of the SIMS. These 50 items were then shown to a second panel of experts cognizant of self-determination theory (i.e., graduate students), among these items, 26 were selected by the committee. Twenty-four items were deleted because they presented some conceptual ambiguities with the operational definition of the four motivational constructs. Consequently, the preliminary version of the scale included 8 items for external regulation subscale whereas the other three subscales were formed of 6 items each. Each item was rated on a 7-point Likert scale ranging from 1 (*does not correspond at all*) to 7 (*corresponds exactly*).

Participants

The sample of Study 1 was formed of 195 French Canadian college students² (44% males, 56% females). Participants' mean age was 18.9 years.

Measures

The questionnaire of Study 1 comprised the SIMS and situational measures of perceived competence, concentration, and Behavioral Intentions of Future Persistence toward the activity (BIFP). The French form of the Academic Motivation Scale (AMS; Vallerand et al., 1989) was also included to assess a contextual motivational orientation toward educational activities.

Situational Measures. The measure of perceived competence was adapted from the Perceived Competence toward Life Domains Scale (Losier, Vallerand, & Blais, 1993) and was formed of 7 items (e.g., "Right now, I think that I'm good at this activity") rated on a 7-point Likert scale (1: *not at all in agreement* to 7: *completely in agreement*). Cronbach's α for this scale was .89. Concentration during the task was assessed by six items (e.g., "Right now, I am focusing on this activity") adapted from the study by Vallerand et al. (1989). This measure, rated on a 7-point Likert scale (1: *not at all in agreement* to 7: *completely in agreement*), offered a Cronbach's α of .85. The BIFP scale was made up of two items rated on a 9-point continuum and one item measured on a scale ranging from 0 to 90 min (e.g., "If you had the choice, how much time would you spend again on this activity"). Cronbach α for this measure was .81.³

The Academic Motivation Scale. The French version of the Academic Motivation Scale (AMS; Vallerand et al., 1989) assesses students' contextual (or general) motivation toward educational activities. The AMS is composed of seven subscales. However, in the present study the abridged version containing four subscales was used. One subscale assesses intrinsic motivation (e.g., "Because I experience pleasure and satisfaction when learning new things"). Two subscales assess types of extrinsic motivation: identified regulation (e.g., "Because this will help me make a better choice regarding my career orientation") and external regulation (e.g., "In order to have a better salary later on"). One subscale assesses amotivation (e.g., "I don't know; I can't understand what I am doing in school"). There are 4 items per subscale and thus a total of 16 items. Each item represents a possible reason for going to school. Items are scored on a 7-point Likert scale (1: *not at all in agreement* to 7: *completely in agreement*). The AMS has evidenced high levels of construct and concurrent validity as well as internal consistency (Vallerand et al., 1989). In the present study, Cronbach's α s for the four subscales ranged from .76 to .91.

Procedure

Participants were recruited by an experimenter in their college library. The experimenter selected students who were engaged in an academic activity (e.g., reading a book for a course, completing an assignment) and asked them to complete a brief questionnaire. He carefully

² In the Quebec educational system, students may enroll in College for a 2-year program (the one leading to university) or a 3-year program (for the technical terminal program) between high school and university. It is this educational institution that we will refer to in the paper by the term "College."

³ z-Scores have been performed on the behavioral intentions items in order to compute the Cronbach's α value for this scale.

explained how to fill out the questionnaire and then assured participants that their responses would remain anonymous. Following these instructions, students completed the SIMS as well as scales assessing situational perceptions of competence, concentration, BIFP, and the AMS.

Results

Preliminary Analyses

Correlation analyses showed that 10 of the 26 items were weakly related with items assessing the same dimension. These 10 items were thus removed. The experimental version of the SIMS included four items for each subscale (see Appendix). Means for the 16 items varied considerably, ranging from 1.56 to 5.53 (possible range 1 to 7). Standard deviations indicated adequate variability for all items, ranging from 1.18 to 2.34.

Factor Analysis

A Maximum Likelihood (ML) factor analysis with oblimin rotation was performed on the SIMS. Results indicated four factors and the total variance accounted for was 65%. These findings are in line with Gorsuch (1983) who has noted that extracted variances of 40%–50% reflect an adequate factor structure for self-report scales. Table I presents factor loadings, eigenvalues, and explained variance for each factor. Each item loaded on their respective factor with no cross-loading except for the identified Regulation Item 2 (e.g., “Because I think that this activity is good for me”), which had a smaller cross-loading on the intrinsic motivation factor.

Internal Consistency of the Four Subscales

The subscales internal consistency values (Cronbach’s α) were: intrinsic motivation = .95, identified regulation = .80, external regulation = .86, and amotivation = .77. Nunnally (1978) has suggested that self-report scales with internal consistencies in the .70–.80 range are acceptable for research purposes. The SIMS subscales meet this criterion.

Construct Validity

Construct validity was assessed by three correlational analyses. The first analysis revealed that most correlations among the four subscales represented a simplex-like pattern of relations (see Table II). That is, overall the pattern of interrelations among the subscales is formed of an ordered pattern in which those subscales adjacent along the self-determination continuum correlated more positively than those more distant along the continuum. For example, intrinsic motivation correlated positively with identified regulation ($r = .36$) but negatively with amotivation ($r = -.41$). To evaluate the congruence of this simplex-like pattern, we used a procedure proposed by Ryan and Connell (1989). First, we assigned an adjacency index to the correlations between the subscales according to how close these subscales are along the self-determination continuum, as follows: r (intrinsic motivation, identified regulation) = 3, r (intrinsic motivation, external regulation) = 2, r (intrinsic motivation, amotivation) = 1, r (external regulation, identified regulation) = 3, r (amotivation, identified regulation) = 2, and r (amotivation, external regulation) = 3. Then we computed the amount of variance accounted for by this adjacency index in the

obtained correlations among the subscales. This analysis revealed a congruency coefficient of .71, demonstrating that about 50% of the variance in correlations of the simplex-like pattern is accounted for by the adjacency index. The value of the congruency coefficient observed in the present study was similar to the one observed in Ryan and Connell (1989; i.e., .79).

The second correlational analysis was performed between the SIMS subscales and perceived competence and concentration and behavioral intentions. Correlations are presented in Table III. Strong positive correlations (SIMS subscales with motivational determinant and consequences) were observed with intrinsic motivation and identified regulation but strong negative ones with amotivation and external regulation. These correlations were in line with the self-determination theory predictions.

The third correlational analysis was conducted between the SIMS subscales and the AMS subscales. Because, the AMS assesses a contextual orientation in the school context and the SIMS was completed toward school activities, positive and specific interrelations should be observed between comparable subscales of these two instruments (see Vallerand, 1997 to this effect). Results supported this hypothesis. The most positive correlations were those involving each SIMS subscale and their respective counterpart of the AMS. For instance, the intrinsic motivation subscale of the SIMS was positively correlated with the intrinsic motivation subscale of the AMS ($r = .31$). The same pattern of results was also observed for the other three subscales (see Table IV).

Discussion

Results of this initial study revealed that the SIMS is composed of four identifiable factors reflecting the theorized constructs of self-determination theory (Deci & Ryan, 1985). Moreover, results pertaining to internal consistency revealed acceptable Cronbach's α values. The SIMS also exhibited an adequate construct validity as evidenced by three correlational analyses. That is, correlations coefficients among the subscales reflected the theorized simplex-like pattern. Furthermore, construct validity was supported through correlations in line with hypotheses derived from self-determination theory. That is, perceived competence, concentration, and BIFP were associated with the SIMS subscales according to the self-determination continuum. Lastly, specific and positive interrelations were found between the SIMS and AMS subscales. This last result was in line with the specificity hypothesis postulated by Vallerand's (Vallerand, 1997) hierarchical model of intrinsic and extrinsic motivation. This hypothesis states that situational motivation toward an activity is related to the contextual motivation relevant to this activity. For example, in the present study, motivation at a point in time toward a specific academic activity was related to a general motivational orientation in the school context. These results suggest that students who, in general, perform their school activities out of choice and pleasure will also show a tendency to perform a situational school activity with these same motivational processes. In sum, results of this first study provided preliminary support for some of the psychometric properties of the SIMS.

STUDY 2: A CONFIRMATORY TEST OF THE FACTOR STRUCTURE

Study 1 has provided support for psychometric properties of the SIMS. However, the sample size of this first study was small and the factor analysis used could not estimate the true scores of items by removing the measurement error. In addition, the invariance of the scale across gender was not assessed. Finally, Study 1 measured a limited number of motivational determinants and consequences.

The purpose of Study 2 was thus to overcome the limitations mentioned above. This was done by (1) using a larger sample size; (2) using confirmatory factor analysis; (3) testing for the invariance of the SIMS across gender; and finally (4) examining additional determinants and consequences of situational motivation to provide further evidence on the construct validity of the scale.

Method

Participants

Participants were 907 French Canadian college students (44% males, 56% females). Their mean age was 18.9 years.

Measures

The questionnaire included the experimental version of the SIMS as well as scales assessing perceived competence, perceived autonomy, positive emotions, and task interest. The perceived competence scale included four items adapted from Study 1, whereas the perceived autonomy scale was formed of four items (e.g., “I feel free to do this activity”) adapted from the Autonomy Perceptions in Life Contexts Scale (Blais & Vallerand, 1992). These two scales presented Cronbach’s α values of .78 and .74, respectively. Positive emotions (e.g., “Right now, I feel happy”) and task interest (e.g., “This activity arouses my interest”) were assessed by four items each. These two measures were adapted from a previous study (Vallerand et al., 1989) and had Cronbach’s α values of .85 and .91, respectively. Responses to scales of perceived competence, perceived autonomy, positive emotions, and task interest were rated on a 7-point Likert scale ranging from 1 (*not at all in agreement*) to 7 (*completely in agreement*).

Procedure

The experimenter arrived in the classroom approximately 35 min after the beginning of the course. This time period was chosen to ensure that students had sufficient time to be engaged in the academic activity that they were currently performing. The experimenter then explained how to fill out the questionnaire and subsequently assured participants that their responses would remain anonymous. Following these instructions, students completed the SIMS as well as scales assessing situational perceptions of competence, autonomy, emotions, and task interest.

Results

Confirmatory Factor Analysis

The adequacy of the factor structure was assessed by structural equation modeling with the EQS program. The proposed model contained four latent constructs measured by four indicators each. A covariance matrix with the 16 observed variables was used as a database for the confirmatory factor analysis. Moreover, skewness and kurtosis values for all variables were considered satisfactory. The specified model was tested with standardized coefficients obtained from the ML method of estimation. A growing body of research indicates that ML performs reasonably well when the data are multivariate, normally distributed, and the sample size is large enough as in this study (e.g., Chou & Bentler, 1995). The EQS program provides different indices to ascertain the model fit. Herein, we used the chi-square, the Comparative Fit Index (CFI), and the Bentler-Bonnet NonNormed Fit Index (NNFI). Models with a CFI and NNFI in the .90 range will be considered acceptable (Bentler, 1993).

Results of the confirmatory factor analysis showed that the χ^2 was significant, $\chi^2 (98, n = 907) = 856.50, p < .05$, and the NNFI (.89) was somewhat lower than the .90 cut-off value. However, the CFI (.90) was satisfactory. Figure 1 presents the standardized solutions for the factor loadings and error residuals. All hypothesized factor loadings, covariances, error residuals, and factor residuals were found to be significant ($z > 1.96$).

Test of Invariance Across Gender

Based on samples of 397 males and 509 females (1 missing observation for gender), the purpose of these analyses was to test for the equivalence of factor loadings, covariances, and variances across gender. In the least restrictive model (Model 1), no parameters were constrained to be equal across gender, and this model provided a good fit to the data, $\chi^2 (196, n = 907) = 959.788, p < .05$, CFI = .90, NNFI = .88. In Model 2, the factor loadings were constrained to be invariant across gender, and the fit ($\chi^2 (208, n = 907) = 969.54, p < .05$, CFI = .90, NNFI = .88) of this model did not differ significantly from the one of Model 1 (i.e., the χ^2 difference test was nonsignificant). Hence, the factor loadings did not differ between gender. In Model 3, factor loadings, variances, and covariances were constrained to be equal. The fit of this model ($\chi^2 (218, n = 907) = 982.00, p < .05$, CFI = .90, NNFI = .88) did not significantly differ from the one of Model 1 thereby indicating that variances and covariances were invariant across gender. Uniquenesses were not constrained to be invariant in those models because this test is considered to be excessively stringent (Byrne, 1995). In sum, these three CFA analyses revealed that the factor structure of the SIMS is invariant across gender.

Gender Differences

A multivariate analysis of variance (MANOVA), revealed a significant multivariate effect of gender on the four subscales, $F (4, 901) = 2.68, p < .05$. Univariate F -tests revealed that amotivation was the only significant variable across gender, $F (1, 904) = 6.62, p = .01$ ($M = 2.10$ for males and $M = 1.90$ for females). However, the effect size for this difference was very small ($\eta^2 = .007$; Cohen, 1992).

Internal Reliability and Construct Validity

As in Study 1, Cronbach's α values for the subscales were adequate (intrinsic motivation = .93; identified regulation = .81; external regulation = .75; amotivation = .78). Moreover, the correlation among the SIMS subscales and some motivational determinants and outcomes supported the self-determination continuum described previously, which provided some support for the construct validity of the scale (see Table V).

Discussion

Results of this second study provided confirming evidence for the factorial structure of the scale and its invariance across gender. That is, the SIMS is able to measure adequately the motivational constructs for males and females. Additional support for the internal consistency and construct validity of the subscales was obtained. Although a gender difference was found to be significant on the amotivation variable, this effect was relatively small. For that reason, it will not be discussed further.

These results have some important theoretical implications. More precisely, the interrelations between the SIMS subscales and perceived competence, perceived autonomy, task interest, and positive emotions were in line with hypotheses derived from self-determination theory (Deci & Ryan, 1985). As proposed by self-determination theory higher levels of self-determined situational motivation (i.e., intrinsic motivation and identified regulation) are positively associated with perceived competence and autonomy as well as with task interest and positive emotions.

STUDY 3: VALIDATION BASED ON A MOTIVATIONAL MODEL

Although Studies 1 and 2 have provided information about the construct validity, the factor structure, and the internal consistency of the SIMS, they were exclusively conducted within the realm of academic activities. Moreover, construct validity was evaluated through correlational analyses that do not offer the possibility of integrating determinants and outcomes in a single model. The purpose of Study 3 was thus to assess the construct validity of the scale within a motivational model that captures the psychological processes at play during an interpersonal discussion. This model posits that the four motivational variables play a mediational role between the interpersonal style of the partner of the discussion and behavioral intentions to partake in a similar discussion again in the future. More specifically, as postulated by self-determination theory an autonomy-supportive style from the partner of a discussion should be positively related to intrinsic motivation and identified regulation toward the discussion. On the other hand, this autonomy-supportive style should be negatively associated to external regulation and amotivation. That is, autonomy supportive contexts lead individual to feel that their behaviors are internally caused which foster intrinsic motivation and identified regulation but hamper the development of external regulation and amotivation (Deci and Ryan, 1985). Furthermore, these relationships should be in line with the self-determination continuum. That is, the most positive relationships should be observed with intrinsic motivation followed by identified regulation, whereas the most negative relations should be obtained with amotivation followed by external regulation. Thus, the

more individuals perceive that the discussion partner shows autonomy support (Deci & Ryan, 1985) the more they should feel that they were discussing out of choice and pleasure and the less they should act for external reasons or without a sense of purpose. There is some support in the literature for these hypotheses. For example, research in education, sports, and work has shown that autonomy support is positively associated with self-determined types of motivation (i.e., intrinsic or identified regulation) and negatively to non-self-determined forms of motivation (i.e., external regulation and amotivation; see Vallerand, 1997).

Finally, the four types of motivation should, in turn, be related to behavioral intentions of willingness to partake in a similar discussion. Indeed, because self-determination has been hypothesized to be associated with enhanced psychological functioning (Ryan et al., 1995), one would expect intrinsic motivation to be associated the most with behavioral intentions, followed by identified regulation. In contrast, the most negative relations with behavioral intentions should stem from amotivation, followed by external regulation. Evidence is available to support that motivation is associated with positive outcomes in the interpersonal sphere. For instance, some studies have shown that pleasure derived from a discussion is negatively associated with loneliness (Downs & Javidi, 1990; Hosman, 1991) but positively related to life satisfaction (Barbato & Perse, 1992), the number of social interactions (Barbato & Perse, 1992), and the need for intimacy (Hosman, 1991). Moreover, Blais, Sabourin, Boucher, and Vallerand (1990) have shown that intrinsic motivation and identified regulation in couples' relationship are positively linked to couple satisfaction, whereas amotivation and identified regulation are negatively associated to this variable.

Method

Participants

Participants were 145 French Canadian college students (32% males, 68% females). Their mean age was 18.9 years.

Measures

The questionnaire included the SIMS as well as scales assessing autonomy support, and Behavioral Intentions to Partake in a Similar Discussion (BIPSD) in the future. The perceived autonomy support scale included seven items (e.g., “during the discussion . . . the person respected my opinion”; “. . . the person listened carefully to what I said”) adapted from the Perceived Interpersonal Style Scale (Pelletier, 1992) whereas the BIPSD scale was made up of four items adapted from Study 1. These two scales had a Cronbach's α of .82 and .86, respectively. Items on the Perceived Autonomy Support Scale were rated on a 7-point Likert scale ranging from 1 (*not at all in agreement*) to 7 (*completely in agreement*), whereas those of the behavioral intentions scale were rated on a 9-point continuum.

Procedure

A questionnaire was sent by mail to 484 college students. They were asked to complete the questionnaire with respect to a discussion they recently had with a significant person (e.g., parents, romantic partner, friends). In order to have a vivid memory of the discussion, it was carefully explained that they should complete the questionnaire within 2h following the discussion. Moreover, participation in a lottery with a prize of \$300 was offered to students who completed and sent back the questionnaire. In all, 145 completed questionnaires were returned at a response rate of 30%. This response rate was similar to those of previous studies (e.g., Gajraj, Faria, & Dickson, 1990).

Results

Internal Consistency

As in Studies 1 and 2, Cronbach's α values for the subscales were relatively adequate (intrinsic motivation = .95; identified regulation = .85; external regulation = .62; amotivation = .83).

Path Analysis

The adequacy of the model was tested through path analysis with the EQS program (Bentler, 1993). A path analysis was used instead of a complete latent variable model because of the limited number of participants. The model included 19 parameters to be estimated. That is, six covariances among motivational variables error terms were estimated as well as five residual errors, and eight path coefficients. Herein, the measurement strategy used offered a ratio of 8:1 as compared with a ratio of 2:1 for a complete latent variable model. Consequently, we were confident to obtain trustworthy z -tests on the significance of parameters and to yield correct model evaluation chi-square probabilities. The method of estimation used was ML. Results of this analysis have shown that the chi-square was nonsignificant [$\chi^2(2, n = 145) = 4.79, p > .05$], whereas the CFI (.99) and NNFI (.94) were higher than the .90 cut-off value. In addition, all path coefficients were significant ($z > 1.96$), except the one between external regulation and behavioral intentions (see Fig. 2). Finally, the four types of motivation explained 56% of the variance in the BIPSD variable. Thus, the proposed model was supported.

Discussion

The results of Study 3 extended those obtained in Studies 1 and 2. Once again, the SIMS demonstrated adequate internal consistency within the context of an interpersonal discussion. Thus, internal consistency seems invariant across different activities. Moreover, the proposed model was corroborated thereby providing support for the construct validity of the scale. In addition to the results relevant to the construct validity, results of Study 3 lent further support for self-determination theory. More precisely, it was shown that the autonomy-supportive style of a discussion partner was positively related to self-determined types of motivation. That is, the more individuals perceived that the discussion partner showed some understanding toward them, the more they engaged in the discussion out of choice and pleasure. In contrast, the less individuals felt that the discussion partner was supportive and understanding, the more they were discussing for external reasons and without a sense of purpose (i.e., amotivation). Thus, these findings

replicate in the interpersonal domain those obtained in other fields that have found that the interpersonal style of significant others has an important influence on motivation. Furthermore, results demonstrated that motivation led to some important outcomes. That is, acting out of choice and pleasure sustained behavioral intentions to partake in a similar future discussion, whereas discussing with a lack of purpose impaired such intentions. It should be noted that external regulation was not significantly related to behavioral intentions. This lack of relationship was not expected. However, it should be noted that the first-order correlation was negative and significant ($r = -.20, p < .05$). Because past research has typically used first-order correlations (e.g., Ryan & Connell, 1989; Vallerand et al., 1993) it is difficult to compare those studies with the present one. Thus, future research is needed to shed light on this issue.

STUDY 4: VALIDATION BASED ON MOTIVATIONAL CHANGES

Although Study 3 provided some support for the SIMS psychometric properties, it was based on a concurrent design, which did not allow to verify if the scale was sensible to detect intraindividual changes in motivation. Specifically, because the SIMS was designed to assess motivation at the situational level, one should expect that the SIMS subscales would fluctuate across measurement times.

Two purposes underlie the present study. The first purpose was to verify if the SIMS was sensitive enough to detect intraindividual changes in motivation. The second purpose was to examine the validity of two motivational theories that address complementary and different antecedents of motivation, namely self-efficacy theory (Bandura, 1986) and self-determination theory (Deci & Ryan, 1985, 1991). Self-efficacy theory and self-determination theory share a common postulate: both predict that perceptions of individual competence have a causal influence on motivation. In addition, self-efficacy theory recognizes collective competence (or efficacy) as being important to group or team functioning (Bandura, 1986). Even though both theories acknowledge the importance of competence beliefs in the initiation of action, they differ on the necessary and sufficient cause that affect motivation. On one hand, self-efficacy theory proposes that competence beliefs are a sufficient cause of motivation; on the other hand, self-determination theory postulates that in addition to competence beliefs, autonomy, and relatedness beliefs are essential to the understanding of motivation. Thus, for self-determination theory, it is not only important to consider one's level of perceived competence to understand motivational processes but also one's levels of perceived autonomy and relatedness.

To achieve the aforementioned purposes, we assessed situational motivation and motivational antecedents toward two basketball games. This sport activity was selected because it involves a team's performance where perceived individual competence, perceived collective competence, relatedness, and autonomy are relevant to understand changes in motivation. First, in line with self-determination theory (Deci & Ryan, 1985) and self-efficacy theory (Bandura, 1986) we proposed that perceived individual competence would be positively associated to changes in intrinsic motivation and identified regulation but negatively related to changes in external regulation and amotivation. Second, in line with self-efficacy theory, we predicted that perceived collective competence would be positively associated to changes in intrinsic motivation and identified regulation but negatively related to changes in external regulation and amotivation. Finally, concordant with self-determination theory, we proposed that perceived autonomy and

relatedness would be related, over and beyond perceived individual competence and perceived collective competence, to changes in motivational processes.

Method

Participants

Participants were 150 athletes from 16 collegiate basketball teams (62% males, 38% females). The mean age was 18 year, ranging from 16 to 22 years.

Measures

The perceived individual and collective competence scale comprised three (e.g., I felt I was efficacious playing this game; $\alpha = .87$) and one item (e.g., “My team played well during the game”) respectively (Losier et al., 1993). The perceived autonomy scale included items (e.g., “During the game, I felt free to play”; $\alpha = .55$) adapted from Blais and Vallerand (1992). The perceived relatedness scale was made up of three items (e.g., “During the game, I felt ignored by the other players”—reverse coding; $\alpha = .81$) adapted from Richer and Vallerand (1996). These items were rated on a 7-point Likert scale ranging from 1 (*not at all in agreement*) to 7 (*completely in agreement*).

Procedure

The study involved two waves of data collection. The first wave of data collection occurred immediately after participants’ first game of the season. The experimenter explained how to fill out the questionnaire and subsequently assured participants that their responses would remain anonymous. Following these instructions, students completed the SIMS. The second wave was conducted at the following game (i.e., one week after the first one). Once more, participants were asked to fill out the questionnaire immediately after the game. This questionnaire included scales assessing perceived individual and collective competence, autonomy, and relatedness as well as the SIMS.

Results

Internal Consistency

As in Studies 1, 2, and 3, Cronbach’s α values for the SIMS subscales were adequate for the two waves of data collection: Time-1 intrinsic motivation = .87, Time-2 intrinsic motivation = .93, Time-1 identified regulation = .67, Time-2 identified regulation = .84; Time-1 external regulation = .83, Time-2 external regulation = .90, Time-1 amotivation = .80, Time-2 amotivation = .87.

Regression Analyses

Four regression analyses were performed. The first analysis involved the prediction of Time-2 intrinsic motivation whereas the second, third, and fourth involved respectively the prediction of Time-2 identified regulation, Time-2 external regulation, and Time-2 amotivation. On the first step of each regression analysis, Time-2 motivational constructs were regressed onto Time-1 motivational constructs to form the change score. On the second step, the outcome of the second game was entered (win vs. loss) to control for the potential effect of this variable on motivational processes. On the third step, perceived individual competence and perceived collective competence were entered. Finally, on the fourth step, perceived autonomy and perceived relatedness were entered.

Results obtained from these analyses are presented in Table VI. The first analysis revealed that intrinsic motivation was somewhat stable across measurement times (Step 1, $\beta = .50, p < .001$). In Step 2, the outcome of the game was positively related to changes in intrinsic motivation ($\beta = .22, p < .05$). In Step 3, perceived individual competence ($\beta = .18, p < .01$) and perceived collective competence ($\beta = .35, p < .001$) were positively associated with changes in intrinsic motivation. In Step 4, perceived collective competence ($\beta = .32, p < .001$), perceived autonomy ($\beta = .17, p < .05$), and perceived relatedness ($\beta = .14, p < .05$) were positively related to changes in intrinsic motivation whereas perceived individual competence and the game outcome were no longer significantly related to this change score.

The second analysis showed that identified regulation was also somewhat stable across measurement time (Step 1, $\beta = .37, p < .001$). In step 2, the outcome of the game was not related to changes in identified regulation ($\beta = .02, ns$). In Step 3, perceived individual competence ($\beta = .23, p < .01$) and perceived collective competence ($\beta = .18, p < .05$) were positively associated with changes in identified regulation. In Step 4, perceived autonomy ($\beta = .22, p < .01$) and perceived relatedness ($\beta = .29, p < .001$) were significantly and positively related to changes in identified regulation whereas perceived individual and collective competence were no longer significantly related to this change score.

The third analysis revealed that external regulation was quite stable across measurement times ($\beta = .61, p < .001$). On the other three steps, none of the independent variables were significantly related to changes in external regulation.

The fourth regression analysis showed that amotivation was not very stable across measurement times ($\beta = .27, p < .001$). On the second step, the outcome of the game was not related to changes in amotivation. On the third step, only perceived individual competence was negatively associated with changes in amotivation ($\beta = -.21, p < .05$). On the fourth step, perceived relatedness ($\beta = -.21, p < .05$) was significantly and negatively related to changes in amotivation whereas perceived individual competence was no longer significantly related to this change score.

Discussion

Results of this study provided further evidence on the construct validity of the SIMS by showing that some subscales are sensitive enough to detect intraindividual changes in motivation that could be explained, in part, by the four self-perceptions (i.e., individual and collective competence, autonomy, and relatedness). As proposed by self-efficacy theory (Bandura, 1986), this study

showed the importance of looking beyond individual competence and to address the issue of collective competence to understand intrinsic motivational processes.

However, in line with self-determination theory (Deci & Ryan, 1985), the present study showed that perceptions of relatedness and autonomy are important factors to consider for understanding self-regulatory processes. Specifically, the feeling of being related to one's teammates and feelings of autonomy are important to experience intrinsic and identified regulation or to hinder amotivation, and this seems to take place over and beyond perceptions of individual and collective competence. These results thus challenge self-efficacy theory whereby individual and collective competence are considered as sufficient factors to understand the initiation of action (Bandura, 1986).

It should be noted that perceived individual competence was not related to any changes in motivation when we entered the other self-perception variables (i.e., step 4). These nonsignificant results may stem from the fact that perceived autonomy, perceived collective competence, or perceived relatedness are more important to understand self-regulatory processes than perceived individual competence in a collective activity. Moreover, it is important to bear in mind that none of the self-perceptions were significantly related to external regulation. Further research is thus needed on these issues.

STUDY 5: VALIDATION IN A LABORATORY SETTING

The previous studies have provided correlation-based validation of the SIMS. However, another dimension of construct validation of the SIMS is to move from a correlational to an experimental approach. The purpose of Study 5 was thus to test the sensitivity of the SIMS subscales in relation to an experimentally induced task-focus versus controlling reward manipulation. Past research has shown that controlling rewards undermine intrinsic motivation (e.g., Deci, 1971; Harackiewicz, 1979; Ryan et al., 1983). However, no study so far has observed the effect of a controlling reward on identified regulation, external regulation, and amotivation. This study would thus provide useful information on the effects of rewards on other types of motivation than IM as well as support for the construct validity of the SIMS. It was thus hypothesized that participants in the controlling-reward condition would have lower levels of intrinsic motivation and identified regulation but higher levels of external regulation than participants who were in the task-focus condition (i.e., the focus is on the intrinsic quality of the task). That is, the controlling nature of the reward would lead participants to feel that their behaviors were not internally caused thereby leading to lower levels of intrinsic motivation and identified regulation and higher levels of external regulation. Yet, no hypothesis was formulated for the amotivation subscale. Moreover, it was expected that the finding with the intrinsic motivation subscale of the SIMS should be corroborated by those obtained with other measures of intrinsic motivation such as the free-choice measure, task interest, and behavioral intention of future persistence (Cameron & Pierce, 1994).

Method

Participants

Participants were 40 French Canadian male college students. Their mean age was 19 years. The sample was only formed of men because previous studies have found that task and reward manipulations do not interact with gender (e.g., Ryan et al., 1983).

Design

Participants were randomly assigned to one of the two conditions (i.e., a task-focus or a controlling reward condition). Dependent measures included intrinsic motivation, identified regulation, external regulation, amotivation as assessed by the SIMS as well as task interest, BIFP, and time spent on the activity.

Experimental Task

The experimental task was hidden-figure puzzles, which were cartoon-style drawings by Al Hirshfeld in which the name NINA is embedded several times. These puzzles have been used in previous studies and have been shown to have high levels of intrinsic interest (e.g., Harackiewicz, 1979; Ryan, 1982; Ryan, Koestner, & Deci, 1991; Ryan et al., 1983).

Questionnaires and the Free-Choice Measure

This study included three brief self-report questionnaires. The first one included a 6-item measure of initial task involvement ($\alpha = .78$; e.g., “the NINAs absorb my attention”; Elliot & Harackiewicz, 1996). The second questionnaire was formed of the SIMS and a 3-item task interest scale ($\alpha = .68$; e.g., “the NINAs are interesting”). The third questionnaire contained the BIFP scale ($\alpha = .78$).⁴ The BIFP scale was made up of two items rated on a 9-point continuum and one item measured on a scale ranging from 0 to 90 min (e.g., “If you had the choice, how much more time would you spend again on this activity”).

The free-choice measure was also used to assess intrinsic motivation. More precisely, the experimenter left the participant alone for a period of 480s. Participants were filmed unobtrusively through a camera hidden in the room. The amount of time spent on the puzzles during the free-choice period was recorded. The number of seconds spent by participants working on the puzzles during this period provided the behavioral measure of intrinsic motivation, as it has been done in several intrinsic motivation studies (e.g., Deci, 1971; Ryan et al., 1983).

Procedure

Participants were recruited by an experimenter at their college cafeteria. Participants were invited to collaborate on a perceptual cognitive study that would take place at a large university in

⁴ z-Scores have been performed on the behavioral intentions items in order to compute the Cronbach's α value for this scale.

the Montreal area. In addition, they were told that they would have the chance to win \$300 in prizes for their participation in the study. Of the students who gave their names for participation, 70% came to the laboratory.

On reporting to the experimental room, participants signed a consent form and the task was explained to them. They were told that they had to find embedded words in drawings and then to complete questionnaires. The experimenter also explained that they had 90 s to find the embedded words “NINA” in the drawings. A practice drawing was given to the participants and following completion, they were asked to rate their task involvement (first questionnaire). The purpose of this was to test for possible initial differences on that variable.

All participants were then randomly assigned to either a task-focus or controlling reward conditions (adapted from Ryan et al., 1983, 1991). Participants in the task-focus condition were told that “the NINA is a perceptual game that has been developed by an American cartoonist. We are simply interested in people’s reactions toward this game. The number of embedded words found will be given at the end of the experiment.” Participants in the controlling reward condition were told, “We have received some extra money from a grant, so we will be able to pay participants who do as well as they should. You will receive a \$10 reward at the end of the experiment if you perform up to our standards.”

After completion of the third drawing, the experimenter asked the participants to give their drawings. The experimenter examined the drawings briefly. Then, in line with Ryan et al. (1983), he gave participants feedback according to their experimental conditions. Participants in the task-focus condition were told: “The number of NINA words that you have found is about the average that people find in that kind of experiment.” Participants in the reward condition were told “you have done what you should have done. Here is your \$10. By the way, the number of NINA words that you have found is about the average that people find in that kind of experiment.”

The experimenter then asked participants to complete the second questionnaire, which included the SIMS and the task interest scale. These two scales were administered before the free-choice period (Time 1) to avoid behavioral interference with the inferential process (Quattrone, 1985). When the participant was near finishing to complete the questionnaire, the experimenter started his pager and then indicated that he needed a few minutes to call back the hospital where he works. The experimenter stated that the experiment was over but asked participants to remain in the experimental room as he still had to ask some questions regarding their participation. He then told participants that this would take 8–10 min and that in the meantime they could work on other NINAs, read some magazines, or do whatever they wanted. Participants were then filmed unobtrusively by a hidden camera for a period of 480 s. All participants completed the third questionnaire including the BIFP scale. Following completion of the questionnaires, participants were asked to give their perceptions of the experiment, and then were debriefed.

Results

Preliminary Analyses

Dependent variables were normally distributed, except for the time spent on the activity. More precisely, this variable had a U shape distribution characterized by 7 participants who had spent 0

s on the experimental activity and 4 who had spent 480 s. Moreover, Cronbach's α values for the SIMS subscales were relatively adequate: intrinsic motivation = .86, identified regulation = .65, external regulation = .73, and amotivation = .62. Finally, an analysis of variance (ANOVA) revealed no significant difference between conditions on initial task involvement, $F(1, 38) = 1.08$, $p = .31$.

Construct Validity Based on Multivariate Analyses of Variance

A MANOVA was performed on the following dependent variables: intrinsic motivation, identified regulation, external regulation, and amotivation, task interest completed before the free-choice period as well as the time spent on the activity and the behavioral intentions measure. This analysis revealed a multivariate marginally significant effect, $F(7, 32) = 2.24$, $p = .06$. Table VII presents the means, univariate F -tests, and partial eta square (η^2) for each dependent variable as a function of conditions. Significant differences ($p < .05$) were found on the intrinsic motivation and identified regulation subscales of the SIMS as well as on time spent on the activity and behavioral intentions. Likewise, a marginally significant effect was found on the task interest variable ($p < .10$). Partial eta squares for marginal and significant effects ranged between .08 and .17. Cohen (1977) characterizes $\eta^2 = .01$ as small, $\eta^2 = .06$ as medium, and $\eta^2 = .14$ as large effect size. These results revealed that participants in the controlling-reward condition reported lower levels of intrinsic motivation, identified regulation, task interest, and behavioral intentions and also spent less time on the experimental activity² than participants in the task-focus condition. However, no significant difference was found on the external regulation and amotivation variables.

Discussion

Results of Study 5 supported the construct validity of the SIMS. First, results from analyses of variance were in line with self-determination theory and previous findings in the literature (e.g., Deci, 1971; Harackiewicz, 1979; Ryan et al., 1983). That is, participants in the task-focus condition were more intrinsically motivated than those in the controlling-reward condition. Second, this difference observed on the intrinsic motivation subscale were corroborated by other measures typically used in intrinsic motivation laboratory studies such as task interest, behavioral intentions, and time spent on the activity. Moreover, a difference was found on the identified regulation subscale. This study is the first one to show an influence of reward on identified regulation. Thus, future research is needed to corroborate this result. However, from an intuitive point of view it seems likely that the controlling aspect of reward can not only undermine the pleasure derived from the activity but also internal regulatory processes such as perceptions of choice and importance of the activity for oneself.

It should be noted that the external regulation subscale was not affected by the conditions. The present study is the first one to show that rewards have an effect on intrinsic motivation but not on external regulation. This finding is particularly intriguing because self-determination theory proposed that controlling rewards should hamper feeling of autonomy and thus should foster external regulation. Clearly, future research is needed to understand when external rewards will produce external regulation and when they will not. For instance, it is possible that external regulation increases only when the rewards are still operative. In addition, no difference was observed on the amotivation subscale. It is possible that only learned helplessness manipulations

(e.g., lack of control on certain task or induced failure) have an impact on this variable. Thus, future study should investigate factors that can more readily affect the amotivation subscale.

GENERAL DISCUSSION

The purpose of the present five studies was to develop and validate a measure of situational (or state) motivation, namely the SIMS. The present results provided strong support for the psychometric properties of the SIMS. First, results from exploratory and confirmatory factor analyses revealed that the SIMS has a four-factor structure that reflects the theorized constructs of intrinsic motivation, identified regulation, external regulation, and amotivation. Second, as expected, internal consistency values for each subscale computed within the confines of the five studies were satisfactory. Third, the construct validity of the SIMS was supported through the results of multiple analyses. Thus, correlational analyses revealed a simplex-like pattern of relations among the SIMS subscales as well as relations in line with the self-determination continuum between the SIMS subscales and variables assessing motivational determinants and outcomes. In addition, a path analysis provided support for the “autonomy support → motivation → intentions” motivational sequence. Furthermore, results from multiple regression analyses showed that the SIMS was sensitive enough to detect intraindividual changes in motivation that were explained, in part, by the three self-perceptions proposed by self-determination theory (i.e., perceptions of competence, autonomy, and relatedness; Deci & Ryan, 1985). Finally, the construct validity of the SIMS was also supported through the experimental design of Study 5 that showed that controlling rewards decreased both intrinsic motivation and identified regulation. The present findings lead to a number of methodological and theoretical implications as well as directions for future research. These are detailed below. Finally, we also underscore some of the limitations of the present studies.

Methodological Implications

The major methodological implication of the present five studies is that empirical support has been obtained for a new instrument (the SIMS) that overcomes at least two important limitations of traditional measures of situational motivation. A first limitation that is overcome is that, contrary to traditional measures such as the free-choice period, the SIMS assesses not only intrinsic motivation but also different types of extrinsic motivation, and amotivation. This is important as motivational research currently goes beyond the mere study of intrinsic motivation. In fact, if as Ryan et al. (1995, p. 405) suggested “much of human behavior is not intrinsically motivated,” then we need to assess other types of motivational constructs such as extrinsic motivation and motivation. The SIMS allows researchers this possibility.

A second limitation that the SIMS addresses is that contrary to past measures, the SIMS clarifies the assessment of motivation by equating the operational and psychological definition of motivation. Typically, past measures have used motivational consequences and determinants as indices of intrinsic motivation. For instance, most self-report scales ask participants how they feel (an affective consequence). Such an approach is highly problematic. On the other hand, the SIMS focuses on the very nature of motivation, that is the “Why” of behavior (e.g., McClelland, 1985). By using this approach, it is then possible to equate the operationalization of motivation with its

conceptual definition that refers to the perceived reasons of task engagement (Deci & Ryan, 1985; Harter, 1981; Vallerand, 1997).

The strategy employed in the SIMS is important not only because it clarifies the operational definition of motivation but also because it allows us to assess with more precision the motivation (or motivations) at play in a given situation, something that the free-choice measure (and other measures) is ill-equipped to do. Indeed, some researchers have found that persistence during the free-choice period could reflect not only intrinsic motivation but also different forms of extrinsic motivation such as identified regulation (e.g., Deci et al., 1994) and introjected regulation (Ryan et al., 1991). Therefore, it could prove hazardous to operationalize the free-choice measure as solely an index of intrinsic motivation. Even Deci and Ryan (1985, p. 34; *italic added*) themselves concluded

“Like all operational definitions it—*the free choice period*—is not perfectly correlated with the psychological definition, so it requires the use of some perspective in its application. A simplistic use of the operational definition, without proper judgement, has led to some confusing experimental findings.”

Because some confusion may exist when interpreting results obtained from the free-choice period, we believe that it is preferable to use the SIMS either by itself or in conjunction with the time spent on the activity as we have done in Study 5. In doing so, we have been able to show that a controlling-reward not only affects intrinsic motivation but also identified regulation—an effect that would be impossible to discover using only the free-choice period. We propose that by distinguishing motivation from its consequences, it then becomes possible to determine when intrinsic as well as extrinsic motivation will produce cognitive, affective, and behavioral consequences. Because the SIMS is a multidimensional measure of motivation that focuses on the conceptual definition of motivation (or the “Why” of behavior) it is in a unique position to allow us to reach that goal. In sum, we believe that the SIMS provides an interesting methodological advantage over the free-choice period and other instruments and thus could lead to a more complete understanding of motivational processes.

Theoretical Implications

The present set of studies leads to a number of theoretical contributions. First, the present research showed that intrinsic motivation, identified regulation, external regulation, and amotivation are operative at the situational level and are related as theoretically predicted by self-determination theory to individuals’ perceptions of competence, autonomy, and relatedness in a given situation. For example, to the best of our knowledge, Study 3 is the first study to provide support for self-determination theory in a specific situation involving an interpersonal discussion. That is, contrary to previous studies (e.g., Blais et al., 1990), we did not ask participants to report their motivations in general (i.e., at the contextual level) toward interpersonal relationships but to report their motivations toward a single current situation.

In addition, results of Study 4 showed that motivation changed from one situation to another and that in line with self-determination theory these changes could be largely explained by self-perceptions of competence, autonomy, and relatedness. Results from Study 4 thus provide support for the notion that motivation is not limited to stable representations such as personality traits, or

general contextualized tendencies, but that it represents an important dynamic entity that is operative and responsive to specific situations (Ryan, 1995; Vallerand, 1997). Of course, further work is needed in order to better understand how these fluctuations in motivation at the situational level produce either disturbance or agency in general functioning. It may be, as proposed by Vallerand (1997), that cumulative motivational changes at the situational level produce over time an effect on more general motivational aspects (see Postulate 4 of the Hierarchical model on the bottom-up effect; Vallerand, 1997 for more information). For instance, our athlete who plays several games without playing well may over time experience a loss of contextualized (or generalized) intrinsic motivation toward basketball. In turn, if this sport activity is very important to his/her self-definition this loss of intrinsic motivation toward basketball might over time have an impact on his/her global self-regulation in everyday life (i.e., global motivation). These deficits in general self-regulation could in turn lead to psychological distress and even depression. Future research on this issue appears warranted.

A second theoretical contribution of the present research is that it sheds light on the relative contribution of self-efficacy theory (Bandura, 1986) and self-determination theory (Deci & Ryan, 1985) to the understanding of motivational changes. Results of Study 4 indicated that self-efficacy beliefs were not sufficient to explain motivational processes in a field setting. In line with self-determination theory, results from Study 4 showed, that one also had to consider perceptions of autonomy and relatedness in order to more fully predict changes in motivation. Thus, while providing support for self-determination theory, these results underscore the limits of self-efficacy theory because this latter theory does not address the contribution of autonomy and relatedness in self-regulation. However, in line with self-efficacy theory (Bandura, 1986), the results from Study 4 revealed that collective competence was found to be an important predictor of changes in intrinsic motivation. This finding is particularly interesting because it suggests that group representations in the self can be associated with individualistic types of motivation, a source of influence that, until now, has been neglected by intrinsic/extrinsic motivation researchers.

A third theoretical contribution of the present research stems from results of Study 5 that revealed that a controlling reward had a negative impact on both intrinsic motivation and identified regulation. These results corroborate those of other studies with respect to intrinsic motivation (e.g., Harackiewicz, 1979; Ryan et al., 1983) and are in line with meta-analyses on the effects of rewards on intrinsic motivation (see Deci, Koestner, & Ryan, 1999 for a recent meta-analysis of 130 studies on this issue). This finding provides further support for the proposition that rewards obtained contingently upon one's explicit engagement in the activity decrease intrinsic motivation. What would appear important in the present case is that rewards were found to undermine both behavioral persistence and the intrinsic motivation subscale of the SIMS. This result is in line with our position that a loss of intrinsic motivation was responsible for the lack of behavioral persistence in Study 5. In addition, the fact that in Study 5 the controlling reward also had a negative effect on another type of motivation, namely identified regulation, reinforces our contention that behavioral persistence may be energized by more than just intrinsic motivation. Because Study 5 is the first study to report such an undermining effect of a controlling reward on identified regulation, this finding needs to be replicated. More important, research is needed in order to identify the nature of the psychological processes responsible for such effects. For instance, is the loss of identified regulation due to a decrease in perceived autonomy as proposed by self-determination theory?

In addition, Study 5 has important implications for how one conceptualizes the relationship between intrinsic and extrinsic motivation. At least two positions have been advocated in the literature. A first one proposes that intrinsic and extrinsic motivation are interactive. They can thus be seen at extreme points of the same continuum (e.g., Harter, 1981). That is the two motivations are inversely related: when intrinsic motivation is high, extrinsic motivation is low and vice versa. A second position proposes that intrinsic and extrinsic motivation are additive (Atkinson, 1964) or at least orthogonal and therefore lie on two different continuum (Deci & Ryan, 1985; Vallerand, 1997). Because past research has typically assessed only intrinsic motivation (either through the free-choice period or self-report questionnaires) and not extrinsic motivation, very little information exists on their relationship following the reception of rewards. Results from Study 5 showed that a controlling reward decreased both intrinsic motivation and identified regulation, but did not affect external regulation. It thus appears that the relationship between intrinsic and extrinsic motivation is more complex than anticipated and depends at least on the type of extrinsic motivation. An additive relationship seems to exist with a self-determined type of extrinsic motivation (identified regulation). However, an orthogonal relation seems to exist with a non-self-determined type of extrinsic motivation (external regulation). Consequently, a loss of intrinsic motivation does not necessarily entail an increase in extrinsic motivation as proposed by some theorists (Harter, 1981). It depends on the type of extrinsic motivation. These findings also have implications regarding the way we should assess intrinsic motivation. Because the relationship between intrinsic and extrinsic motivation is not interactive, these constructs should be assessed independently from each other. In addition, the self-determined (i.e., identified regulation) and non-self-determined (i.e., external regulation) types of extrinsic motivation should be distinguished. The SIMS allows these distinctions.

A final implication of the present research, again from Study 5, is that it disconfirms the conclusion of Eisenberger and Cameron (1996) to the effect that tangible rewards produce no significant drop in intrinsic motivation as assessed through attitudinal measures (i.e., task interest, enjoyment, or satisfaction or a combination of these). Based on the results from their metaanalysis, Eisenberger and Cameron have questioned the validity of self-determination theory. However, the lack of significant effect of tangible rewards on intrinsic motivation assessed through self-report questionnaires has been challenged by a recent exhaustive metaanalysis. In this metaanalysis, Deci, Koestner, and Ryan (1999) showed that most types of tangible contingent rewards produce a loss of intrinsic motivation as assessed by self-reports. Metaanalysis by Eisenberger and Cameron (1996) involved 44 studies, whereas that of Deci et al. included three times that number ($k = 130$). Through an additional metaanalysis Deci et al. (1999) also showed that it is the controlling aspect of rewards that undermine intrinsic motivation. Results from the present experimental study (Study 5) provide strong support for the overall conclusion of Deci et al. and show, contrary to Eisenberger and Cameron, that controlling rewards do undermine intrinsic motivation as assessed by the SIMS (as well as the free-choice period measure). It would thus appear that the conclusion arrived at by Eisenberger and Cameron (1996) to the effect that the negative effects of tangible rewards occurs under highly restricted and easily avoidable conditions is erroneous and misleading.

Limitations

Although the present results provide strong support for the psychometric properties of the SIMS, at least five limitations should be taken into consideration when interpreting these findings.

First, although we used the terminology determinants and outcomes, it is inappropriate to make strong causal inferences because the first four studies used a correlational design. However, the findings of these four studies are in line with a large body of research including several laboratory studies that reveal that controlling situational factors do undermine intrinsic motivation and in turn motivational changes do lead to a number of important cognitive, affective, and behavioral consequences (see Vallerand, 1997 for an integrative review).

A second limitation is that the present studies pertained to only three life contexts, namely education, interpersonal relationships, and leisure (sport). Although Blais et al. (1990) showed that these are the three most important life contexts for college students, it nevertheless remains that other contexts such as work, health, and spirituality are also important. Third, participants who took part in the present studies were all college students. It would be important to ascertain the validity of the scale with other populations such as the working and elderly populations. Fourth, only a limited number of variables were used to assess the construct validity of the SIMS. Thus, additional research on the construct validity of the SIMS is needed. Fifth, the SIMS do not assess the introjection dimension. Future studies should verify if the inclusion of this subscale is necessary to further our understanding of situational behaviors.

In sum, the study of intrinsic and extrinsic motivation has progressed considerably since Deci's (Deci, 1971) initial research on intrinsic motivation. Much of the work that has followed at the situational level has used unidimensional measures. However, without a multidimensional measure of situational intrinsic and extrinsic motivation, we are limiting our possibility to address important theoretical issues. Although additional research needs to be conducted on the SIMS, the present research reveals that the scale has adequate psychometric properties and can prove quite useful in studying situational motivation in a multidimensional fashion in both laboratory and field settings.

References

- Abramson, L. Y., Seligman, M. E. P., & Teasdale, J. D. (1978). Learned helplessness in humans: Critique and reformulation. *Journal of Abnormal Psychology, 87*, 49–74.
- Amabile, T. M., Dejong, W., & Lepper, M. R. (1976). Effects of externally imposed deadlines on subsequent intrinsic motivation. *Journal of Personality and Social Psychology, 34*, 92–98.
- Atkinson, J. W. (1964). *An introduction to motivation*. New York: Van Nostrand Reinhold.
- Bandura, A. (1986). *Social foundations of thought and action: A social cognitive theory*. Englewood Cliffs, NJ: Prentice Hall.
- Barbato, C. A., & Perse, E. M. (1992). Interpersonal communication motives and the position of elders. *Communication Research, 19*, 516–531.
- Bentler, P. M. (1993). *EQS structural equation program manual*. Los Angeles: BMDP statistical software.
- Blais, M. R., Sabourin, S., Boucher, C., & Vallerand, R. J. (1990). Toward a motivational model of couple happiness. *Journal of Personality and Social Psychology, 59*, 1021–1031.
- Blais, M. R., & Vallerand, R. J. (1992). *Construction et validation de l'échelle des perceptions d'autonomie dans les domaines de vie* [Development and validation of the Autonomy Perceptions in Life Contexts Scale]. Unpublished manuscript, Université du Québec à Montréal.
- Byrne, B. M. (1995). *Structural equation modeling with eqs and eqs/windows: Basic concepts, applications, and programming*. Thousand Oaks, CA: Sage.
- Cameron, J., & Pierce, W. D. (1994). Reinforcement, reward and intrinsic motivation: A meta-analysis. *Review of Educational Research, 64*, 363–423.
- Chou, C. P., & Bentler, P. M. (1995). Estimates and tests in structural equation modeling. In R. H. Hoyle (Ed.), *Structural equation modeling: Concepts, issues, and applications*, (pp. 37–55). Thousand Oaks (Cal.): Sage.
- Cohen, J. (1992). A power primer. *Psychological Bulletin, 112*, 155–159.
- Conti, R., Amabile, T. M., & Pollack, S. (1995). The positive impact of creative activity: Effects of creative task engagement and motivational focus on college students' learning. *Personality and Social Psychology Bulletin, 10*, 1107–1116.
- Deci, E. L. (1971). Effects of externally mediated rewards on intrinsic motivation. *Journal of Personality and Social Psychology, 18*, 105–115.

- Deci, E. L. (1987). Theories and paradigms, constructs and operations: Intrinsic motivation research is already exciting. *Journal of Social Behavior and Personality*, 2, 177–185.
- Deci, E. L., Koestner, R., & Ryan, R. M. (1999). The undermining effect is a reality after all — Extrinsic rewards, task interest, and self-determination. Reply to Eisenberger, Pierce, and Cameron (1999) and Lepper, Henderlangrand Gingras (1999). *Psychological Bulletin*, 125, 692–700.
- Deci, E. L., Eghrari, H., Patrick, B. C., & Leone, D. R. (1994). Facilitating Internalization: The self-determination theory perspective. *Journal of Personality*, 62, 119–142.
- Deci, E. L., & Ryan, R. M. (1985). *Intrinsic motivation and self-determination in human behavior*. New York: Plenum.
- Deci, E. L., & Ryan, R. M. (1991). A motivational approach to self: Integration in personality. In R. Dienstbier (Ed.), *Nebraska Symposium on motivation: vol. 38. Perspectives on motivation*. (p. 237–288). Lincoln: University of Nebraska press.
- Diblasio, L., Chantal, Y., Vallerand, R. J., & Provencher, P. (1995, October). *Effets de la récompense et de la punition sur la motivation intrinsèque* [Effects of reward and punishment on intrinsic motivation]. Paper presented at the Société Québécoise pour la Recherche en Psychologie, Ottawa, Ontario.
- Downs, V., & Javidi, M. (1990). Linking communication motives to loneliness in the lives of older adults: An empirical test of interpersonal needs and gratifications. *Journal of Applied Communication Research*, 18, 32–48.
- Duda, J. L., Chi, L., Newton, M., Walling, M., & Catley, D. (1995). Task and ego orientation and intrinsic motivation in sport. *International Journal of Sport Psychology*, 26, 40–63.
- Eisenberger, R., & Cameron, J. (1996). Detrimental effects of reward: Reality or myth? *American Psychologist*, 51, 1153–1166.
- Elliot, S. J., & Harackiewicz, J. M. (1996). Approach and avoidance achievement goals and intrinsic motivation: A mediational analysis. *Journal of Personality and Social Psychology*, 70, 461–475.
- Fisher, C. D. (1978). The effects of personal control, competence, and extrinsic reward systems on intrinsic motivation. *Organizational Behavior and Human Performance*, 21, 273–288.
- Gajraj, A. M., Faria, A. J., Dickson, J. R. (1990). A comparison of the effect of promised and provided lotteries, monetary and gift incentives on mail survey response rate, speed and cost. *Journal of the Market Research Society*, 32, 141–162.
- Gorsuch, R. L. (1983). *Factor analysis*. Hillsdale, NJ: Erlbaum. Harackiewicz, J. M. (1979). The effects of reward contingency and performance feedback on intrinsic motivation. *Journal of Personality and Social Psychology*, 37, 1352–1363.

- Harter, S. (1981). A new self-report scale of intrinsic versus extrinsic orientation in the classroom: Motivational and informational components. *Developmental Psychology, 17*, 300–312.
- Hosman, L. A. (1991). The relationships among need for privacy, loneliness, conversational sensitivity, and interpersonal communication motives. *Communication Reports, 4*, 73–80.
- Koestner, R., Ryan, R. M., Bernierie, F., & Holt, K. (1984). Setting limits in children's behavior. The differential effects of controlling versus informational styles on intrinsic motivation and creativity. *Journal of Personality, 52*, 233–248.
- Losier, G. F., Vallerand, R. J., & Blais, M. R. (1993). Construction et validation de l'échelle des perceptions de compétence dans les domaines de vie (EPCDV) [Development and validation of the Perceived Competence in Life Contexts Scale]. *Science et comportement, 23*, 1–16.
- Markland, M., & Hardy, L. (1997). On the factorial and construct validity of the Intrinsic Motivation Inventory: Conceptual and operational concerns. *Research Quarterly for Exercise and Sport, 69*, 20–32.
- Mayo, R. J. (1977). The development and construct validation of a measure of intrinsic motivation (Unpublished doctoral dissertation, Purdue University, 1976). *Dissertation Abstracts International, 37*, 5417b. University Microfilms No. 77–7491.
- McAuley, E., Duncan, T., & Tammen, V. V. (1989). Psychometric properties of the intrinsic motivation inventory in a competitive sport setting: A confirmatory factor analysis. *Research Quarterly for Exercise and Sport, 60*, 48–58.
- McAuley, E., & Tammen, V. V. (1989). The effects of subjective and objective competitive outcomes on intrinsic motivation. *Journal of Sport and Exercise Psychology, 11*, 84–93.
- McClelland, D. C. (1985). *Human motivation*. London, England: Scott, Foresman, & Co.
- Nunnally, J. C. (1978). *Psychometric theory* (2nd edition). San Francisco: Jossey-Bass.
- Pelletier, L. G. (1992). *Construction et validation de l'échelle des perceptions du style interpersonnel* [Development and validation of the Perceived Interpersonal Style Scale]. Unpublished manuscript, Université d'Ottawa.
- Pretty, G. H., & Seligman, C. (1984). Affect and the overjustification effect. *Journal of Personality and Social Psychology, 46*, 1241–1253.
- Quattrone, G. A. (1985). On the congruity between internal states and action. *Psychological Bulletin, 98*, 3–40.
- Reeve, J., & Deci, E. L. (1996). Elements of the competitive situation that affect intrinsic motivation. *Personality and Social Psychology Bulletin, 22*, 24–33.

- Richer, S., Blanchard, C., & Vallerand, R. J. (1998). *The role of relatedness in turnover intentions: A work motivational model*. Manuscript submitted for publication.
- Richer, S., & Vallerand, R. J. (1996). Construction et validation de l'échelle du sentiment d'appartenance sociale [Construction and validation of the perceived relatedness scale]. *Revue Européenne de Psychologie Appliquée*, *48*, 129–137.
- Ryan, R. M. (1982). Control and information in the intrapersonal sphere: An extension of cognitive evaluation theory. *Journal of Personality and Social Psychology*, *43*, 450–461.
- Ryan, R. M. (1995). The integration of behavioral regulation within life domains. *Journal of Personality*, *63*, 397–429.
- Ryan, R. M., & Connell, J. P. (1989). Perceived locus of causality and internalization: Examining reasons for acting in two domains. *Journal of Personality and Social Psychology*, *57*, 749–761.
- Ryan, R. M., Deci, E. L., & Grolnick, W. S. (1995). Autonomy, relatedness, and the self: Their relation to development and psychopathology. In D. Cicchetti & D. J. Cohen (Eds.), *Developmental psychology: Vol.1. Theory and methods* (618–655). New York: John Wiley & Sons.
- Ryan, R. M., Koestner, R., & Deci, E. L. (1991). Ego-involved persistence: When free-choice behavior is not intrinsically motivated. *Motivation and Emotion*, *15*, 185–205.
- Ryan, R. M., Mims, V., & Koestner, R. (1983). Relation of reward contingency and interpersonal context to intrinsic motivation: A review and test using cognitive evaluation theory. *Journal of Personality and Social Psychology*, *45*, 736–750.
- Seifriz, J. J., Duda, J. L., & Chi, L. (1992). The relationship of perceived motivational climate to intrinsic motivation and beliefs about success in basketball. *Journal of Sport and Exercise Psychology*, *14*, 375–391.
- Sheldon, K. M., Ryan, R. M., & Reis, H. T. (1996). What makes for a good day? Competence and autonomy in the day and in the person. *Personality and Social Psychology Bulletin*, *22*, 1270–1279.
- Vallerand, R. J. (1997). Toward a hierarchical model of intrinsic and extrinsic motivation. In M. P. Zanna (Ed.), *Advances in experimental social psychology* (pp. 271–360). New York: Academic Press.
- Vallerand, R. J., Blais, M. R., Brière, N. M., & Pelletier, L. G. (1989). Construction et validation de l'échelle de Motivation en Éducation (ÉME) [Construction and Validation of the Academic Motivation Scale]. *Canadian Journal of Behavioral Science*, *21*, 323–349.

- Vallerand, R. J., & Fortier, M. S. (1998). Measures of intrinsic and extrinsic motivation in sport and physical activity: A review and critique. In J. Duda (Ed.), *Advancements in sport and exercise psychology measurement* (pp. 81–101). Morgantown. Fitness information technology, Inc.
- Vallerand, R. J., & Reid, G. (1984). On the causal effects of perceived competence on intrinsic motivation: A test of cognitive evaluation theory. *Journal of Sport Psychology*, 6, 94–102.
- Vallerand, R. J., & Reid, G. (1988). On the relative effects of positive and negative verbal feedback on males' and females' intrinsic motivation. *Canadian Journal of Behavioral Sciences*, 20, 239–250.

Figure 1. Results of the confirmatory factor analysis: Study 2.

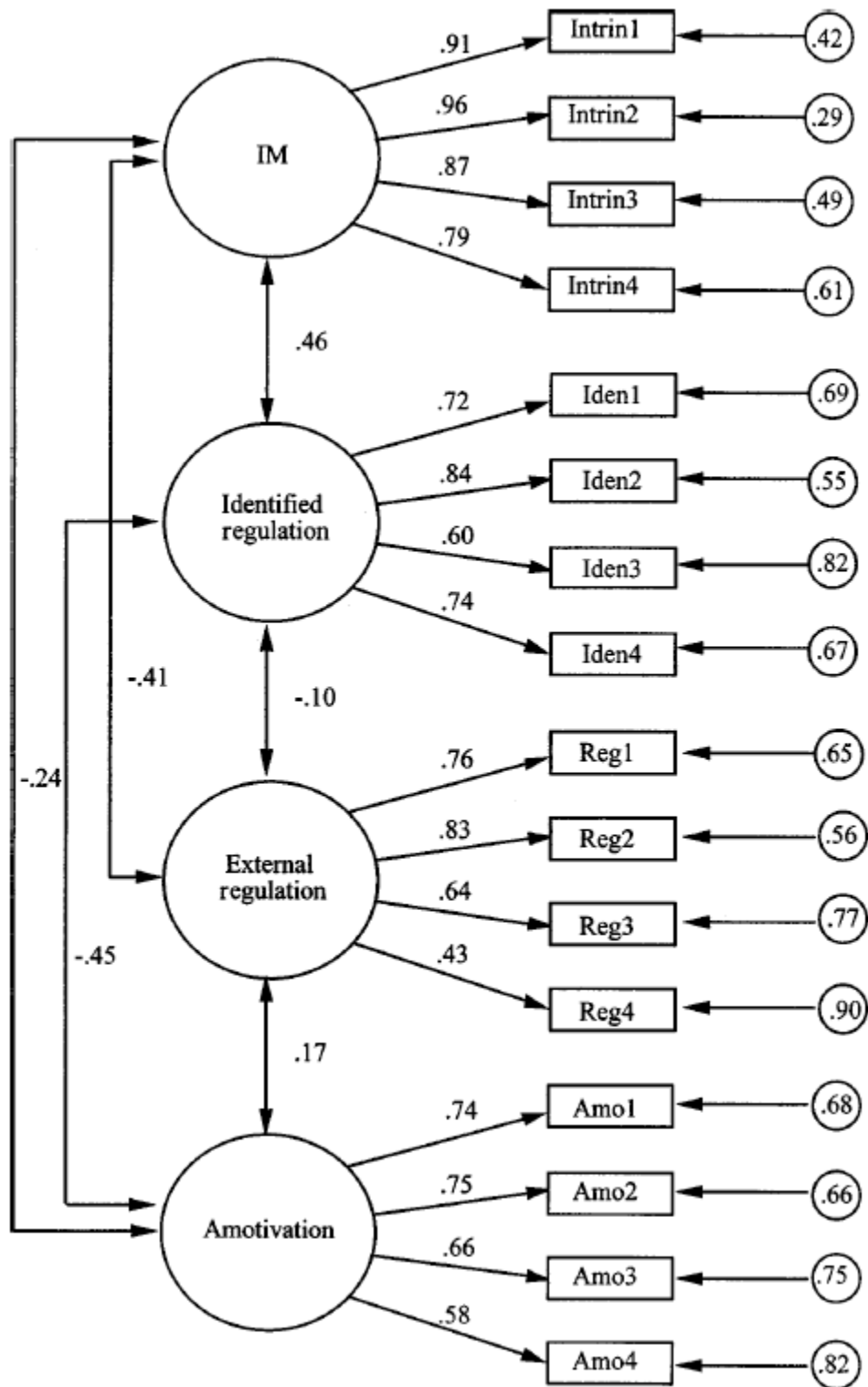

Figure 2. Results of the test of the motivational model of interpersonal discussion: Study 3 (All parameters are significant at $z > 1:96$).

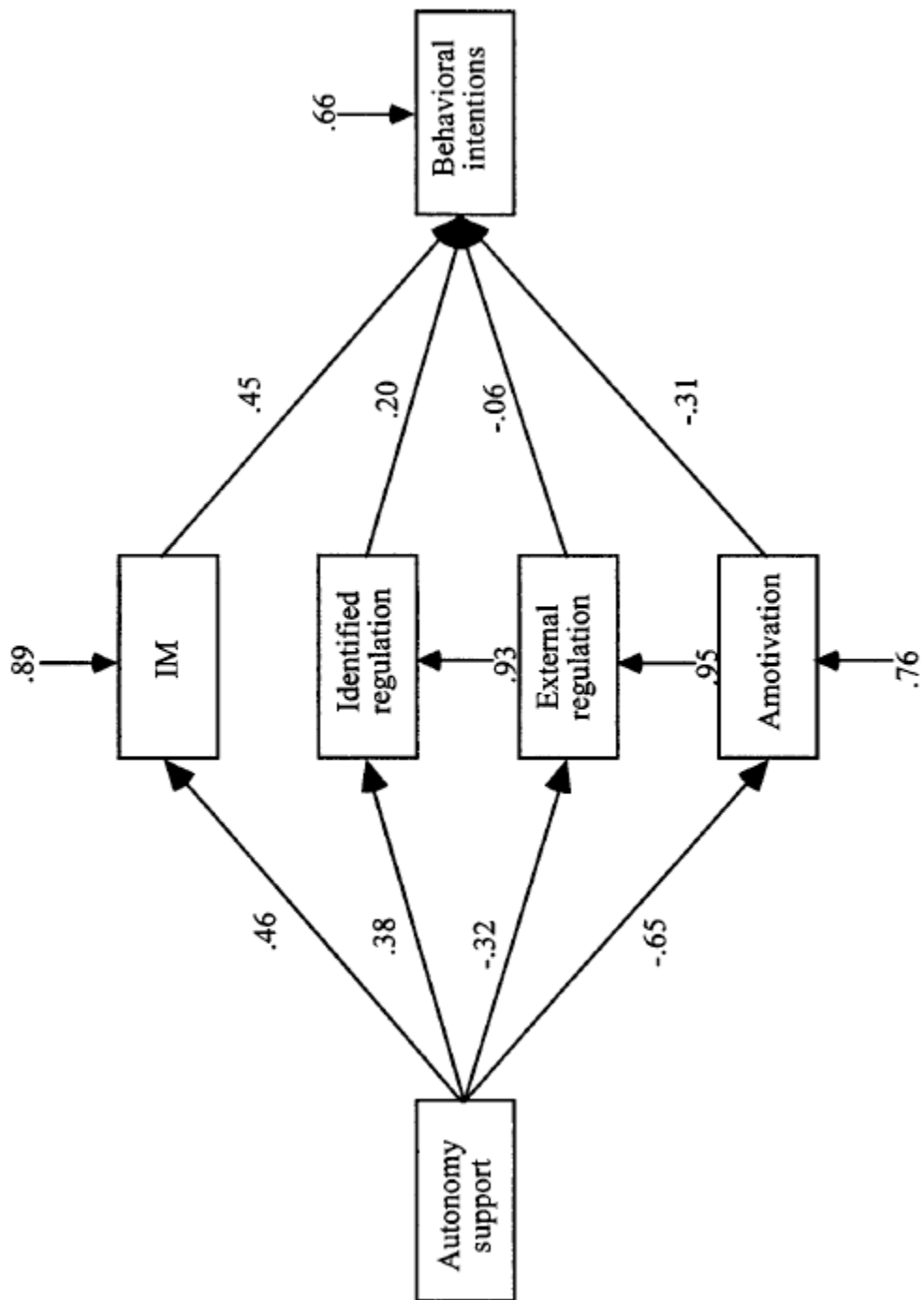

Table 1. Factor Loadings from The Exploratory Factor Analysis: Study 1

Items	Factors			
	1	2	3	4
Intrinsic motivation				
Because I think that this activity is interesting	0.91			
Because I think that this activity is pleasant	0.90			
Because this activity is fun	0.89			
Because I feel good when doing this activity	0.83			
Identified regulation				
Because I am doing it for my own good		0.77		
Because I think that this activity is good for me	0.31	0.60		
By personal decision		0.57		
Because I believe that this activity is important for me		0.52		
External regulation				
Because I am supposed to do it			0.85	
Because it is something that I have to do			0.75	
Because I don't have any choice			0.69	
Because I feel that I have to do it			0.58	
Amotivation				
There may be good reasons to do this activity, but personally I don't see any				0.83
I do this activity but I am not sure if it is worth it				0.74
I don't know; I don't see what this activity brings me				0.55
I do this activity, but I am not sure it is a good thing to pursue it				0.54
Eigenvalues	5.70	2.63	1.33	0.73
Explained variance	35.60	16.40	8.30	4.50

Table 2. Simplex-Like Pattern of Correlations Among the SIMS Subscales: Study 1

	SIMS subscales			
	1	2	3	4
Intrinsic motivation	—			
Identified regulation	.36**	—		
External regulation	-.58**	-.15*	—	
Amotivation	-.41**	-.53**	.26**	—

* $p < .05$. ** $p < .01$.

Table 3. Correlations Between SIMS Subscales, Determinant, and Consequences of Situational Motivation: Study 1

SIMS subscales	Determinant (Perceived competence)	Consequences	
		Concentration	BIFP
Intrinsic motivation	.54*	.35*	.56*
Identified regulation	.37*	.34*	.47*
External regulation	-.43*	-.21*	-.29*
Amotivation	-.44*	-.44*	-.46*

Note. BIFP = Behavioral intentions of future persistence toward the activity.

* $p < .01$.

Table 4. Correlations Between SIMS Subscales and AMS Subscales: Study 1

SIMS subscales	AMS subscales			
	Intrinsic motivation	Identified regulation	External regulation	Amotivation
Intrinsic motivation	.31**	.09	-.19**	-.18*
Identified regulation	.17*	.21**	-.03	-.26**
External regulation	-.02	.11	.27**	.08
Amotivation	-.12	.14	.14*	.48**

* $p < .05$. ** $p < .01$.

Table 5. Correlations Between SIMS Subscales, Determinant, and Consequences of Situational Motivation: Study 2

SIMS subscales	Determinants		Consequences	
	Perceived competence	Perceived autonomy	Emotions	Task interest
Intrinsic motivation	.41*	.46*	.61*	.80*
Identified regulation	.33*	.58*	.37*	.40*
External regulation	-.23*	-.54*	-.23*	-.33*
Amotivation	-.37*	-.37*	-.23*	-.37*

* $p < .01$.

Table 6. Regression Analyses: Study 4

Measure	Step 1		Step 2		Step 3		Step 4	
	β	t	β	t	β	t	β	t
Time-2 intrinsic motivation								
Time-1 intrinsic motivation	.50	7.05***	.49	7.11***	.41	5.80***	.35	5.79***
OGA			.22	3.18**	.10	1.51	.09	1.53
PIC					.18	2.74**	.09	1.29
PCC					.35	5.25***	.32	4.89***
PA							.17	2.46*
PR							.14	2.02*
R^2		.25		.30		.47		.52
R^2 change		.25		.05		.17		.05
F change		49.67***		10.13***		23.50***		7.50***
Time-2 identified regulation								
Time-1 identified regulation	.37	4.80***	.37	4.78***	.32	4.31***	.21	2.96**
OGA			.02	0.40	-.07	-1.04	-.10	-1.41
PIC					.23	2.95**	.07	0.98
PCC					.18	2.28*	.12	1.59
PA							.22	2.78**
PR							.29	3.63***
R^2		.14		.14		.24		.38
R^2 change		.14		.00		.10		.14
F change		22.99***		0.06		9.72***		15.69***
Time-2 external regulation								
Time-1 external regulation	.62	9.48***	.62	9.46***	.62	9.39***	.62	9.32***
OGA			-.04	-0.62	-.04	-0.55	-.04	-0.57
PIC					-.05	-0.75	-.05	-0.67
PCC					.02	0.30	.03	0.39
PA							.03	0.41
PR							-.04	-0.56
R^2		.37		.37		.37		.37
R^2 change		.37		.00		.00		.00
F change		89.84***		0.53		0.75		0.83
Time-2 amotivation								
Time-1 amotivation	.27	3.43***	.27	3.43***	.24	3.05**	.17	2.16*
OGA			.08	1.02	.12	1.59	.13	1.65
PIC					-.21	-2.56*	-.13	-1.45
PCC					-.04	-0.45	.01	0.15
PA							-.10	-1.12
PR							-.21	-2.31*
R^2		.07		.07		.13		.18
R^2 change		.07		.00		.05		.05
F change		11.76***		1.06		4.08*		4.53

Note. OGA: outcome of the game (win vs. loss), PIC: perceived individual competence, PCC: perceived collective competence, PA: perceived autonomy, PR: perceived relatedness.

* $p < .05$. ** $p < .01$. *** $p < .001$.

Table 7. Means (M) for the SIMS Subscales, Task Interest, Time Spent on the Activity, and BIFP Scores as a Function of Conditions: Study 5

	Conditions		<i>F</i>	<i>p</i>	η^2
	Task (<i>n</i> = 20)	Controlling reward (<i>n</i> = 20)			
SIMS subscales					
Intrinsic motivation	4.86	4.03	6.64	.01	.15
Identified regulation	3.98	3.34	4.10	.05	.10
External regulation	2.65	2.66	0.00	.97	.00
Amotivation	2.21	2.39	0.30	.59	.00
Task interest	5.57	5.10	3.29	.08	.08
Time spent on the activity	325.80	183.40	7.98	.01	.17
BIFP ^a	0.26	-0.26	4.01	.05	.10

Note. η^2 = Effect size; BIFP = Behavioral intentions of future persistence toward the activity. The SIMS subscales and the task interest variable means are based on 7-point Likert type scale (the higher the score the higher the motivation and task interest). Time spent on the activity could range between 0 and 480 s. Wilks was used as the multivariate *F*-test.

^aScore-z.

Appendix

Directions: Read each item carefully. Using the scale below, please circle the number that best describes the reason why you are currently engaged in this activity. Answer each item according to the following scale: 1: *corresponds not at all*; 2: *corresponds a Very little*; 3: *corresponds a little*; 4: *corresponds moderately*; 5: *corresponds enough*; 6: *corresponds a lot*; 7: *corresponds exactly*.

Why are you currently engaged in this activity?							
1. Because I think that this activity is interesting	1	2	3	4	5	6	7
2. Because I am doing it for my own good	1	2	3	4	5	6	7
3. Because I am supposed to do it	1	2	3	4	5	6	7
4. There may be good reasons to do this activity, but personally I don't see any	1	2	3	4	5	6	7
5. Because I think that this activity is pleasant	1	2	3	4	5	6	7
6. Because I think that this activity is good for me	1	2	3	4	5	6	7
7. Because it is something that I have to do	1	2	3	4	5	6	7
8. I do this activity but I am not sure if it is worth it	1	2	3	4	5	6	7
9. Because this activity is fun	1	2	3	4	5	6	7
10. By personal decision	1	2	3	4	5	6	7
11. Because I don't have any choice	1	2	3	4	5	6	7
12. I don't know; I don't see what this activity brings me	1	2	3	4	5	6	7
13. Because I feel good when doing this activity	1	2	3	4	5	6	7
14. Because I believe that this activity is important for me	1	2	3	4	5	6	7
15. Because I feel that I have to do it	1	2	3	4	5	6	7
16. I do this activity, but I am not sure it is a good thing to pursue it	1	2	3	4	5	6	7

Codification key: Intrinsic motivation: Items 1, 5, 9, 13; Identified regulation: Items 2, 6, 10, 14; External regulation: Items 3,7, 11, 15; Amotivation: Items 4, 8, 12, 16.