

A STUDY OF THE SANITATION OF A
SWIMMING POOL.

Gerould T. Lane

Course V.

1913.

Danger of infection from the water of swimming pools has been the subject of a great deal of discussion in the past few years. Considerable blame has been put upon them with very little actual proof. A swimming pool is often named as the means of infection if the case can in any way have originated there and if no other way of infection can be proven.

During the past two decades public baths have come into very great prominence. In 1890 the first movement towards the establishment of municipal baths was started in New York. Since that time they have increased greatly in number and in popularity until now every city has at least one public bath and every university, school, and Y.M.C.A. of considerable size boasts of a swimming pool. An estimate of the number of people using swimming pools each day would go far into the thousands.

The dangers of infection from swimming pool water can be readily understood. Infection in this manner is naturally divided into two parts, external and internal. External infection is brought about by the water coming in contact with the most susceptible parts of the body such as the eye, ear and various mucous membranes. Many

cases of eye and ear inflammations as well as gonorrhoeal infection have been reported as traced to swimming in contaminated water. Internal infections such as typhoid fever, dysentery and intestinal diseases of all kinds could be brought on by swallowing contaminated water. A swimmer takes a good deal of water into his mouth and naturally swallows some.

Atkins in 1911, in a review of the literature of water infection cited many reports of interesting cases where epidemics of various diseases could be traced to swimming.

Jäger in 1892, reported an intestinal proteus infection known as Weil's disease among ten soldiers of the Ulmer garrison. Investigation showed the presence of a fowl disease in Solfingen on the Blau, a tributary of the Danube. The soldiers bathed in the Danube below the point of intersection of the rivers. Some dead fowls were found floating in the river. In their bodies were found fluorescent bacilli of the proteus type. These same bacilli were found in the feces of the patients and in the water of the river. By inoculation the bacilli produced the disease in fowls.

Pfuhl in 1888, reported 49 cases of "typhoid^{oid} with

jaundice" from bathing in the Elbe at Altoona. Schäfer reports the same disease following bathing in the Oder near Brunswick. Lenhartz states that, during an epidemic of typhoid in Hamburg, a man fell into the Elbe and swallowed considerable water. A few days later he was attacked by a severe gastro-intestinal trouble, with liver and side swelling. Klein and Schütz observed six cases of soldiers having similar infections. All the men shortly before the onset of the disease had been swimming in a river near the mouth of the city drainage canal. The water here was undoubtedly badly polluted.

In Japan, Shiga published his observations on an epidemic of dysentery in the village of Mitaknura. Near the town was a river in which bathing had previously been prohibited. When this restriction was removed, hundreds of the populace took advantage of the opportunity and went swimming. In four days an epidemic involving 413 cases broke out. On investigating the cause of the epidemic, Shiga found that a fatal case of dysentery had existed a little way above the village. The soiled clothes and bedding from the patient had been washed in the river. This established most unquestionably the facts that the river water carried the diseases

and that many people were infected while swimming in the water.

A large number of cases have been reported of the spread of infections by means of the water of swimming pools. Dr. Reece in 1908, in a discussion of Dr. Mair's paper on enteric fever at Belfast, reported the occurrence of 34 cases of the disease at the garrison of Walmer, from the use of a swimming pool filled with salt water. The intake of the pool was only about 100 yards from the outlet of the Walmer sewer. The dirty, sewage polluted water could be distinguished spreading out into the salt water near the intake of the pool. About 10 per cent of the men using the pool were infected. Only one case of fever appeared among the men who did not use the pool. The epidemic ended when the use of the pool was stopped.

Baginsky was strongly convinced of the danger from swimming pool infection. His own son, a healthy eight year old boy, started to take swimming lessons in a public swimming pool, and of course swallowed considerable water. He was taken ill with a typhoid-like gastro-intestinal trouble with fever and headache from which he recovered in a few days. Later he had an at-

tack of rhinitis. Other cases of a like nature were reported as caused by infection from the same pool.

Fehr tells of an interesting case in Berlin. A young man had a severe eye infection for six days after using a public bath. After treatment for six days the case was cured. The man went swimming again in the same place and the trouble returned. Among users of the bath 20 severe cases of conjunctivitis appeared.

Schulz in the same city reports 18 cases of trachoma among young men following bathing in a public swimming pool. It was found that one of the servants in the bath house had "Schlimme Augen", which may have been the source of the infection in the water.

Cobb of Boston has recorded two cases of ear infections arriving from swimming pool bathing. In one case a boy after being cured went again to the pool and ethmoiditis followed. He went swimming a third time with the same result. The other case was one of ethmoiditis and suppurative otitis media, the attack appearing soon after swimming in a pool.

Gonorrheal infection from use of a swimming pool is possible. Hertzka and Sticker each demonstrated the passage of *B. prodigiosus* from infected water into the vagina showing that if gonococci had been present in

the water, infection might have taken place. Skutsch reports the actual occurrence of an epidemic of 236 cases of vulvovaginitis among young school girls in Posen. The girls all used a common swimming pool but did not use the same towels or soap. However the danger from gonorrhoeal infection from swimming pool water is relatively slight as the gonococcus dies rapidly in water. No case of the male being infected in this manner has been reported.

The actual danger from bathing in swimming pools where there is polluted water is hard to determine. The estimation of the amount of contamination of swimming pool water is also difficult. It is hardly right to judge it by the same standards as drinking water. Theoretically the water in a swimming pool should be changed daily, but the cost of water, labor, and fuel has made this prohibitory in a great many cases. Hence the problem remains to find an efficient method of purification so that the water may be kept as near as possible to the standards set for drinking water.

The first requisite for a swimming pool is an initial supply of water that is uncontaminated. Then if it is not possible to change the water daily, suitable means of filtration and disinfection must be de-

vised. If the bacteriological count can be kept low, then some means must be taken into consideration by which the water may be kept physically in good condition. The sides and bottom of the pools must be kept clean and attractive. Of course the numbers of bacteria and the types present have the most importance from a strictly sanitary point of view.

The increase of the bacteria in swimming pool water is due to two causes; multiplication of the initial bacteria and the addition and multiplication of the bacteria from the bodies of the bathers. If then good pure water fills the tank the initial number of bacteria is low and the increase of the harmless bacteria would cause little danger to the users of the pool. But the presence and multiplication of the bacteria from the bathers' bodies is of primary importance as a source of possible danger to other bathers.

Hesse, examining the Albertbade at Dresden; Selter, the Viktoriabade at Bonn; and Hilsun, a bath in Amsterdam, found the initial number of bacteria in the various baths was low. The bacteria increased rapidly for the first few days. A marked decline in the bacterial content followed. After this decrease a sort of

equilibrium was reached and on further use there was comparatively little change in the number of bacteria. The tests were carried out over a period of six days. Hilsun, Hesse and Selter used gelatin media at 20° C, but Hesse also used agar media at 37° C. The following table gives a summary of their results:

	<u>Hilsun</u>	<u>Hesse</u>	<u>Hesse</u>	<u>Selter</u>
	Amsterdam	Dresden	Dresden	Bonn
Day	Gelatin	Gelatin	Agar	Gelatin
1	435	200	200	160
2	20,000	25,000	21,000	29,000
3	10,000	23,000	25,000	43,000
4	2,455	20,000	12,000	---
5	3,600	5,100	7,800	---
6	2,310	5,100	2,100	---

Atkins in tests carried out on the swimming pool of the University of Chicago finds a very large increase in bacteria during three or four days. At the end of two days in one series of tests the bacterial count gave per cubic centimeter 625,000 on gelatin and 500,000 on agar. Another series of tests gave a count at the end of three days of 500,000 on gelatin and 200,000 on agar. Another test of three days developed

1,060,000 on gelatin and 830,000 on agar.

Atkins carried out further tests of three days each, studying the effect of hypochlorite of lime upon the bacterial content of the pool. He found that hypochlorite is an effective disinfectant, destroying over 95% of the bacteria in an hour, when used in the quantity of one part per million. The effect of hypochlorite added in this quantity lasted for two days.

Continuous filtration has been used with considerable success in the purification of swimming pool water. Angel reported a gelatin count of 5,500 bacteria per cubic centimeter in water that had been in use for five months but which was subjected to continuous filtration and aeration. He stated as the advantages of this method, that the water is never unclean, is uniformly heated, and has no odor. There is economy in water, time, and labor.

Bunker, in experiments on the swimming pool at Brown University, found that filtration was successful in keeping the bacterial count between 300 and 400 per cubic centimeter. The filtration plant consisted of a settling plant and sand filter. Nearly the whole amount of water passed through the filter daily.

Little has been published on the use of disinfectants in swimming tanks. Stokes made tests on a Baltimore swimming pool, copper sulphate being used as a disinfectant. He advised the use of one part per million. This gave a considerable reduction in the algae and fermentative bacteria. Alexander described the use of a solution obtained by electrolysis of magnesium chloride which when added to water produced sterility and had no effect on the bathers. There was no data given as to the strength of the solution. Burrage at Purdue University used hypochlorite in a strength of about 0.75 parts per million and obtained a reduction of bacteria of more than 95%. Bunker used calcium hypochlorite in a strength of about 0.5 parts per million with very good results.

Atkins determined the presence of higher organisms in swimming pool water. The principal diatoms found were Asterionella, Synedra, Nitzchia and Tabellaria. They did not multiply to any considerable extent and were quickly destroyed by hypochlorite. Atkins also determined the presence of B.Coli in the water. At the end of three days their presence was demonstrated in 0.1 cubic centimeter. However hypo-

chlorite of lime was found to reduce the number of B.Coli to a considerable extent.

Lewis carried out a series of tests on the swimming pool at Northwestern University for periods of a week. In each series of tests he noted that there was a gradual rise in bacterial content until about the middle of the week after which there was a fall. He explained this by applying the Malthusian Law to bacterial life. Organic food material is added only from contamination by bathers whereas bacteria increase from this cause and also by reproduction. Thus an inhibiting force sets in, which has been recognized to be a considerable factor in the self purification of streams.

Sanitary chemical analyses were also carried out on the Northwestern University pool. They showed a progressive contamination of the water during a week and thus tended to confirm the bacterial counts. Tests were also made with hypochlorite. Two parts per million added two or three times during the week were found to give very good results.

Commercial bleaching powder is now being used in nearly 200 cities of the United States for steril-

izing public water supplies. The efficiency of such a method applied to swimming tanks might appear obvious at first glance. There is, however, this essential difference, the swimming tank water becomes more highly contaminated than the average public drinking supply, and is being continuously reinfected. A public water-supply on the other hand once sterilized may be kept so until delivered. Questions of quantity, method and frequency of application, therefore, arise anew in the case of the swimming tank.

As to the sterilizing of drinking supplies with bleaching powder, the following points are notable: The quantity used - 5 to 15 lbs. per million gallons- is so small as to be inconsequential after reaction. The original material acts quickly, undoubtedly through the liberation of oxygen, from the reaction of the available chlorine and water, resolving itself into calcium hydroxide, which in turn is converted into the carbonate and chloride. While not producing an absolutely sterile water, there is a substantial destruction of all objectionable bacteria, particularly those of intestinal origin. The efficiency of such a treatment in all cases is greater than the figures show, because of the select-

ive action of bleach upon pathogenic types of bacteria. It is generally conceded by sanitarians that spore forms are not affected by hypochlorite treatment, but those normally found in water are not pathogenic to man.

The experimental data used in this thesis were obtained from tests made upon the Harvard Swimming Tank at the Cambridge Y.M.C.A. during a period of seven weeks beginning Monday, February 24, 1913 and ending Saturday April 11, 1913. The analysis of the water in the pool was undertaken in an effort to determine the efficiency of the methods of filtration and disinfection which are in use at that swimming pool and to determine the length of time that may elapse without making a complete change of water and cleansing of the tank without endangering the health of those using the tank.

During the seven weeks of the test the pool was used by from 400 to 500 bathers each week. The possibilities of an indoor swimming tank, such as the Cambridge Y.M.C.A. pool, becoming unhygienic are apparent when one considers the extensive use of such a small body of water, and the absence of sunlight, fresh air, sedimentation and the various forces operative in the self-purification of out-door waters. Furthermore, the

coughing, spitting and snorting of the average swimmer is most favorable to contamination of the water with the disease germs typical of the respiratory tract, as those of tonsillitis, pneumonia, tuberculosis, common colds and sore throat, especially as the temperature of the water in the pool is very favorable for the growth and reproduction of these bacteria. Also the dead organic matter washed from the skins of the bathers serves as a food for the bacteria so that under average conditions, a swimming pool would serve as a very good means of incubation of many common types of bacteria.

The Harvard tank is sixty feet long by twenty feet wide and varies in depth from three and one-half to seven feet, having a total capacity of 55,000 gallons. The initial water supply is from an Artesian well of a depth of 400 feet, the pump being 206 feet below the level of the tank. This pump will supply water at the rate of 50 gallons per minute. At this rate it takes at least 18 hours to completely fill the tank. Adding to this, the time required to draw off the water from the tank and to cleanse the sides and bottom of the tank thoroughly one may easily see that a daily change is impossible under the present condi-

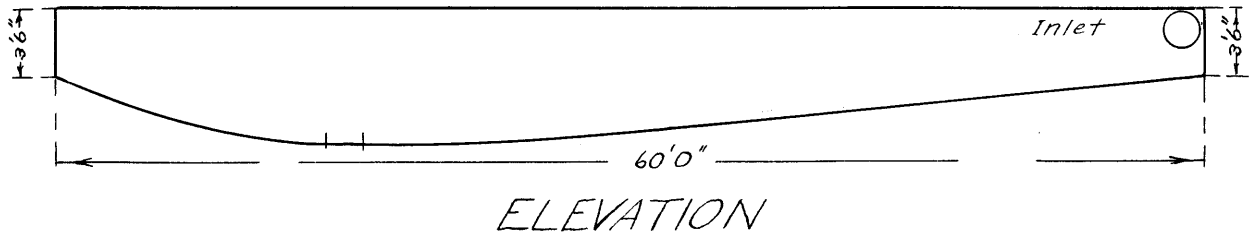
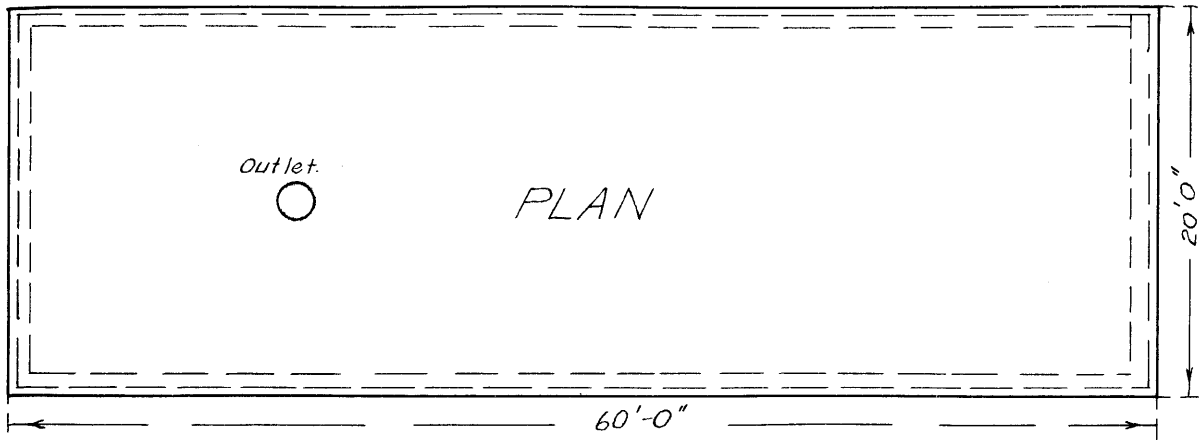

SWIMMING POOL.
CAMBRIDGE Y.M.C.A.

tions. Furthermore a change every few days is impracticable because a complete change of water necessitates the loss of a day's swimming.

In consideration of the problem of keeping a given body of water in the pool in a good and pure condition for some length of time the Cambridge Y.M.C.A. has had installed one of the most modern systems of clarification, purification, and disinfection that can be obtained.

During the hours that the pool is open for use the water is being pumped through a purification system. The water is withdrawn from an outlet on the bottom at the deepest part of the tank by a pump with a capacity of 50 gallons per minute and pumped through a Lynn-Superior quartz filter having an alum coagulation chamber attached. After passing through the filter, the water goes through a heater and from there is returned to the shallow end of the tank.

Every night when the circulating pump is stopped, 5000 gallons of fresh water are pumped in to take the place of the water lost from the splashing. The water is allowed to overflow into the catch-trough around the edge of the tank, so that all the floating matter

may be carried away.

The last thing at night one pound of hypochlorite of lime is added to the water. The addition is made by wrapping the hypochlorite in cheese cloth which is then fastened on the end of a pole and moved about in the water until the lime is all dissolved. In this manner the impurities are all retained within the cloth.

In the morning after sedimentation has taken place, a brush, the type used for vacuum cleaning, is connected with a suction pump and the sediment, hairs and sludge are removed from the bottom and sides of the tank.

The Lynn filter which is in use has a capacity of from 50 to 100 gallons per minute, a height of six feet and a diameter of four and one half feet, and requires a floor space of 54 x 62 inches. It is filled with quartz pebbles one quarter inch in diameter. The filtering surface when supplied with 50 gallons per minute by the pump gives a rate of filtration of 63,000,000 gallons per acre per 24 hours.

The coagulant chamber is one of the most important features of the filter. Some waters lacking in suspended matter to any degree can be readily filtered

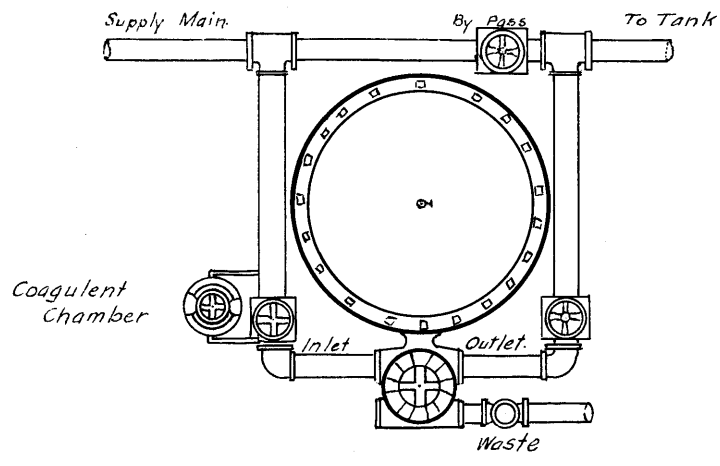

PLAN.

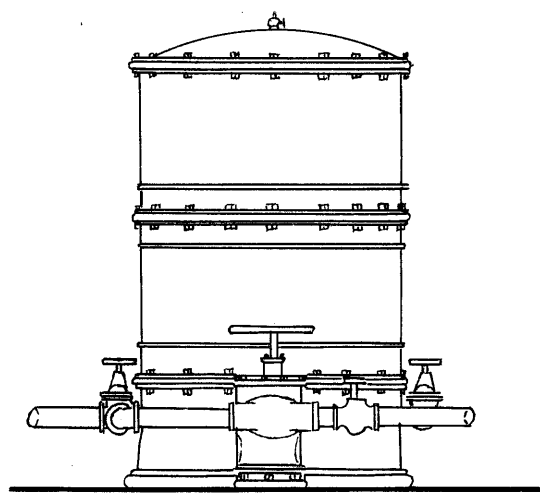

ELEVATION.

STYLE -I- FILTER.

without the use of a coagulant. These cases are comparatively few, and comprise principally supplies from springs or mountain streams. This kind of water is easily passed through a bed of bone carbon by which it is freed from the light particles contained.

Water with a trace of turbidity should be first prepared for filtration by the introduction of an infinitesimal amount of coagulant to facilitate the entire removal of suspended or organic matter. The correct method is to use sulphate of alumina, or common lump alum, which is placed in a tank connected with the raw water inlet. This is fed to the water before entering the filter in the form of a solution; the action is controlled by finely adjusted valves, in amounts varying from one-fifth to one half a grain per gallon, according to the turbidity of the applied water.

On entering the filter the alumina unites with the impurities in the water, drawing thousands of particles into a single globule of sufficient size to prevent its

passage through the interstices of the filtering medium. This combination forms a precipitate which is an insoluble hydrate of alumina, and deposits on top of the filter bed. Thus a feathery film is formed, which is of very high filtering efficiency.

Each day a cleaning process is carried out. The filter is reversed and the aluminum hydroxide, together with the accumulated impurities, is washed out into the waste pipe.

On all the bacteriological work, plates were made from the water on litmus lactose agar and incubated for 48 hours at 37°C to develop all body temperature organisms, and plates were made on nutrient agar-agar and incubated at 20°C for 72 hours to develop all organisms that that temperature favors. Dextrose broth fermentation tubes were inoculated from the water in order to determine by presumptive tests the number of gas producing organisms present.

The first tests consisted of bacteriological and chemical analyses of the raw water of the initial supply. The results were as follows:-

RAW WATER.

Nutrient agar-agar at 20°C	110
Litmus lactose agar at 37°C	200
No gas formers in 5 c.c.	

Chemical Analysis.

Parts per million.

Nitrogen as

Free ammonia	.001
Albuminoid ammonia	.014
Nitrites	.000
Nitrates	.09

Chlorine 30.8

Oxygen consumed .29

The above analyses show that this water is perfectly safe from a sanitary point of view. The high amount of chlorine is only what might be expected of a deep well water in this locality.

On Sunday and Monday, February 23rd. and 24th., the tank was completely filled with water from the Artesian well. During the seven weeks of the test, there was no change of water except for the 5,000 gallons admitted each day to take the place of that lost from splashing and that taken out by the suction cleaner.

Samples at first were taken twice a week. They were all taken from the side of the pool about a foot below the surface of the water. The following table taken from the data obtained from the swimming pool at the Uni-

iversity of Chicago shows that there is no consistent difference in the number of bacteria in different parts of a tank.

A	459	520	54,000
B	453	1,000	42,000
C	585	450	50,000
D	423	860	55,000
E	432	770	98,000
F	495	890	43,000
G	315	870	65,000
H	405	950	86,000

The letters refer to different points of sampling.

The above table shows a very uniform distribution, hence a single sample is representative of the water in the pool, especially when the circulation pump is being used.

The following tables of data show the results of the analyses which were carried out from February 24th. to April 13th.

BACTERIOLOGICAL RESULTS.

	Lactose Agar at 37°C.	Nutrient Agar-agar at 20° C.	Gas Producers in 5cc.	Acid formers.
1	7,000	6,000	1	
2	6,500	4,300	10	
3	140	20	0	
4	20,000	12,000	1	
5	18,000	3,500	1	
6			0	
7	6	6	0	
8	30,000	42,000	0	
9				
10	180,000	150,000	10	40
11				
12	300,000	398,000	3	20
13				
14	50,000	180,000	0	0

CHEMICAL RESULTS EXPRESSED IN PARTS PER MILLION.

	N I T R O G E N A S				Chlorine	Oxygen Consumed
	Free Ammonia	Albuminoid Ammonia	Nitrites	Nitrates		
1	.006	.026	.000	.12	31.6	.29
2					29.6	
3	.022	.072	.001	.18	33.2	.48
4					36.0	
5	.148	.100	.002	.24	34.4	.67
6						
7						
8	.054	.056	.0015	.15	40.0	.95
9						
10	.280	.070	.010	.00	42.4	.71
11						
12	.066	.112	.400	.10	31.2	.95
13						
14	.096	.060	.200	.13	36.0	.83

Plot I.
20°C. Bacterial Count on Nutrient Agar-Agar.

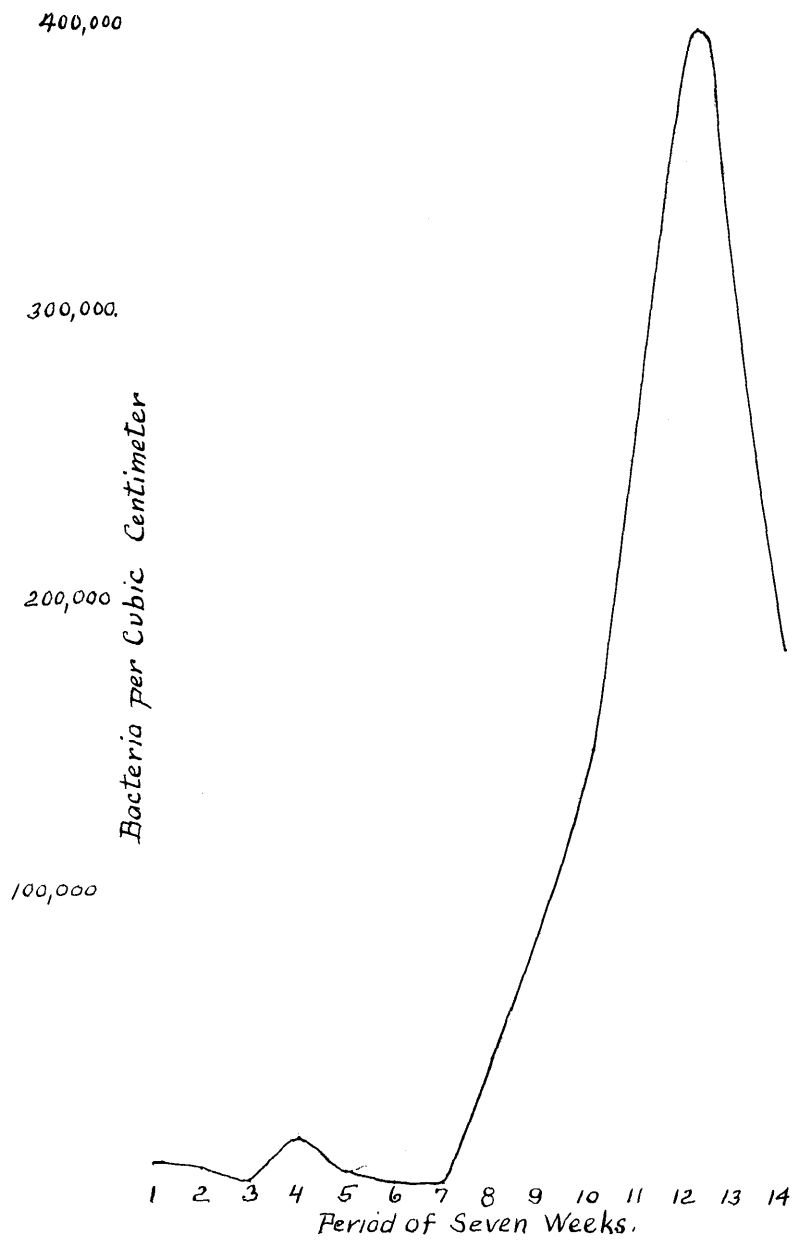

Plot II.
Bacterial Count on Lactose Agar
37°C.

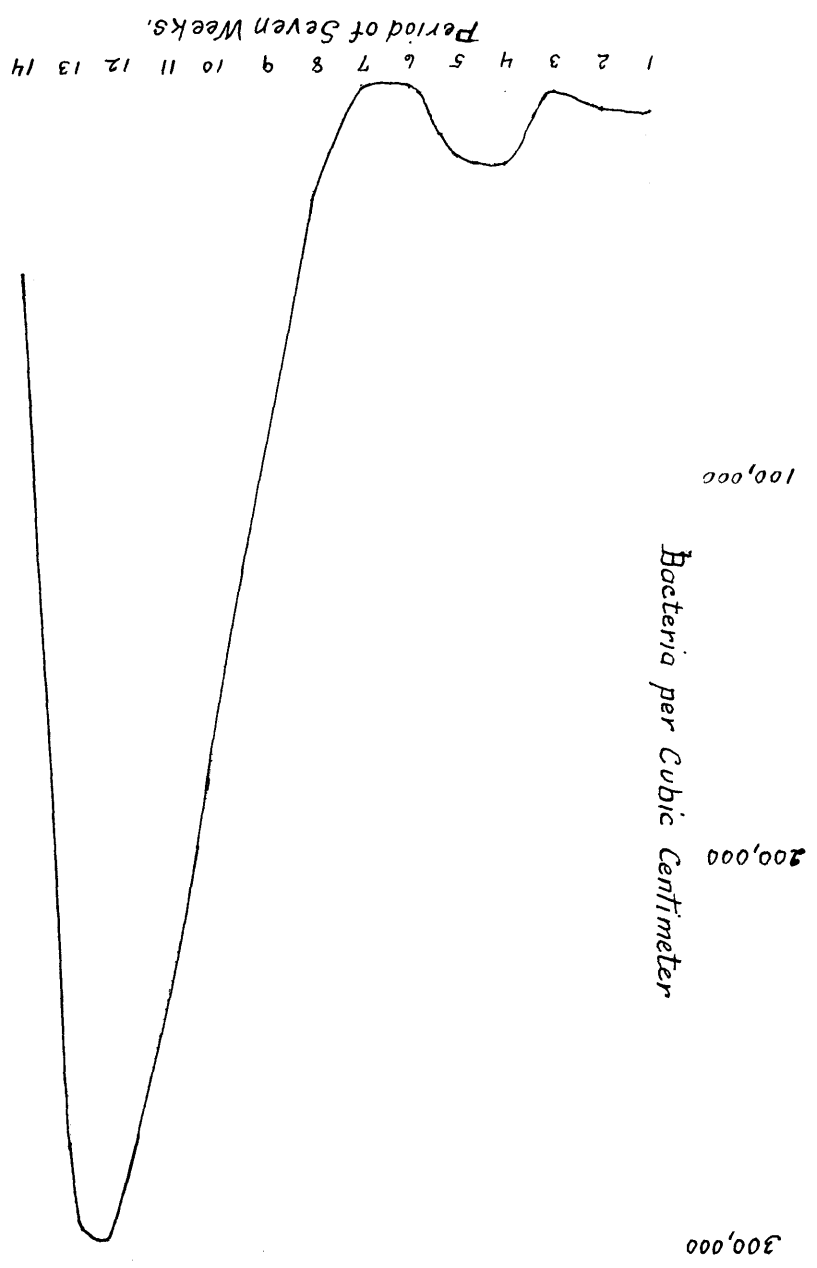

Plot III.
Chemical Analysis — Chlorine.

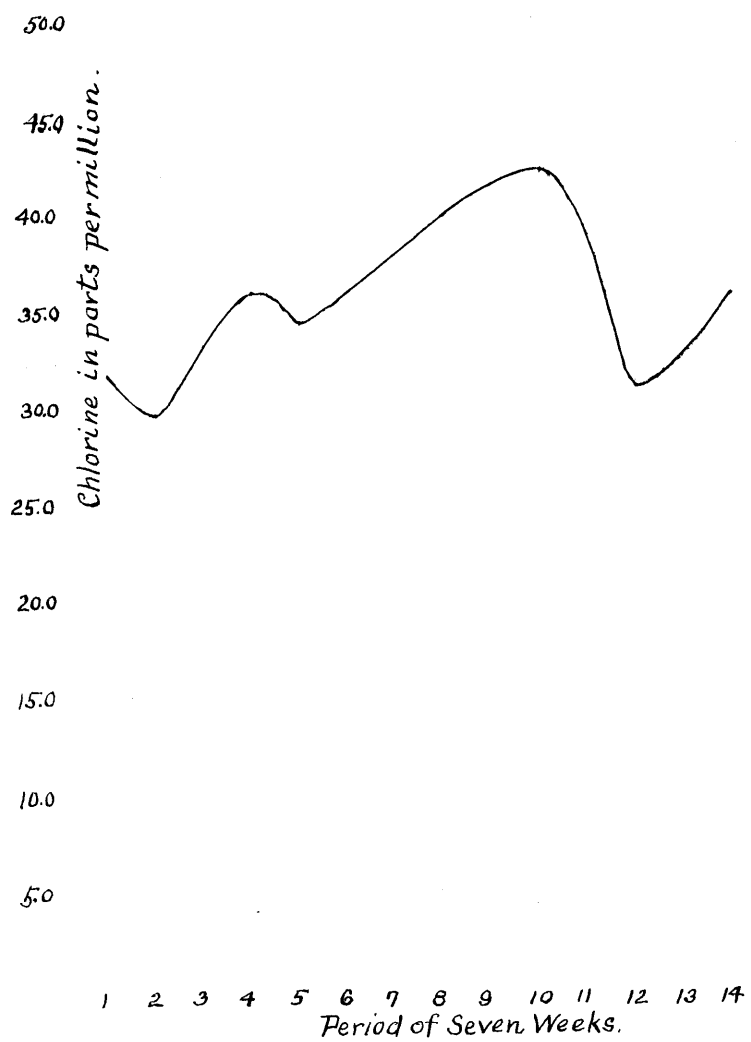

Plot IV
Chemical Analysis - Free Ammonia.

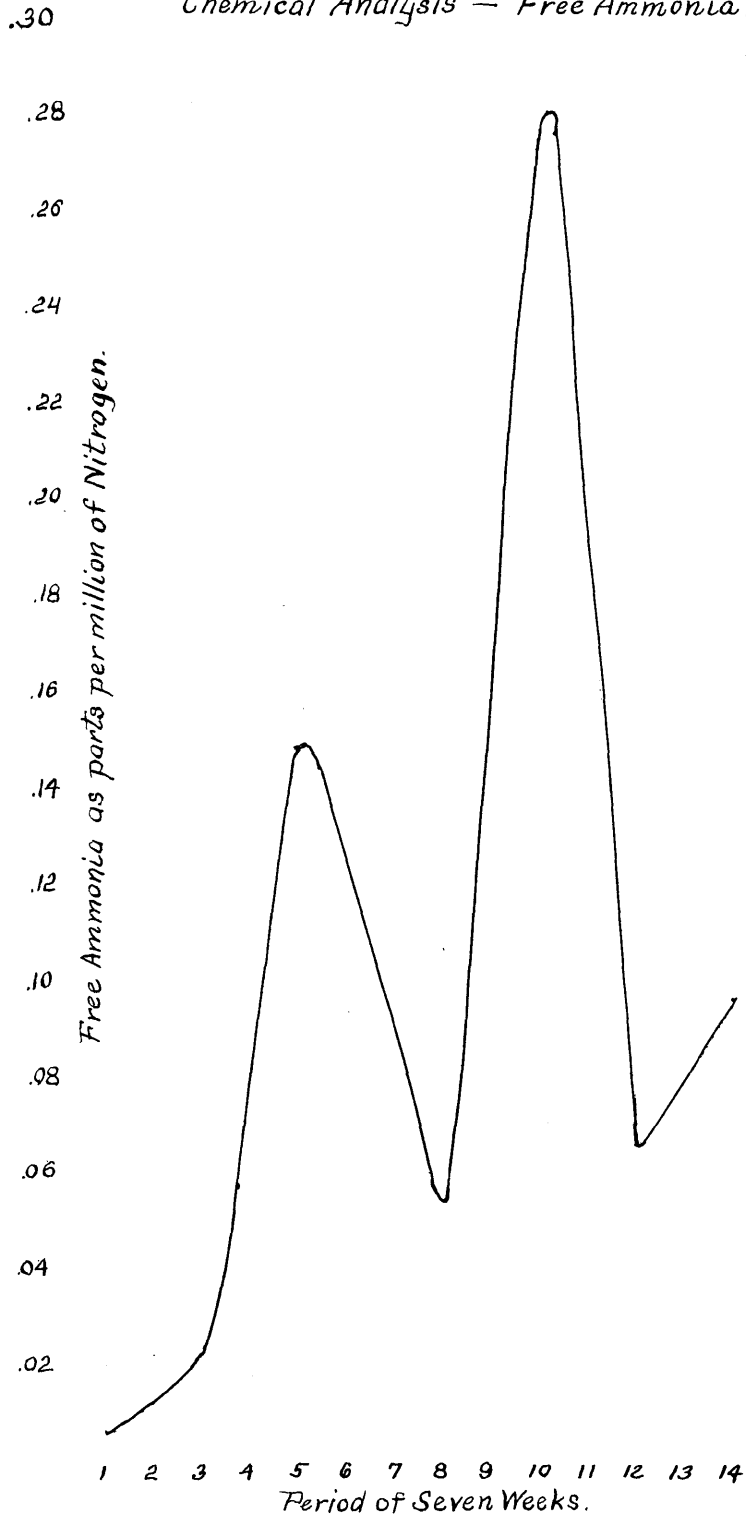

Chemical Analysis ^{Plot V.} — Albuminoid Ammonia.

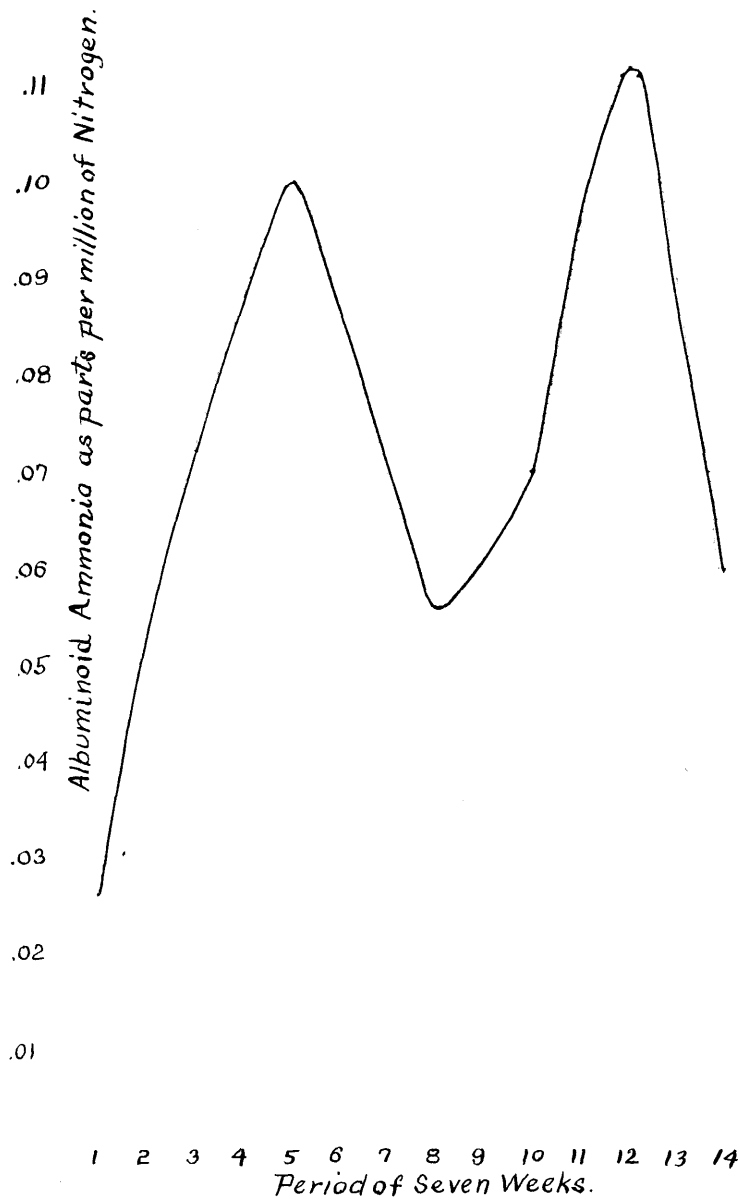

Plot VI
Chemical Analysis — Nitrites.

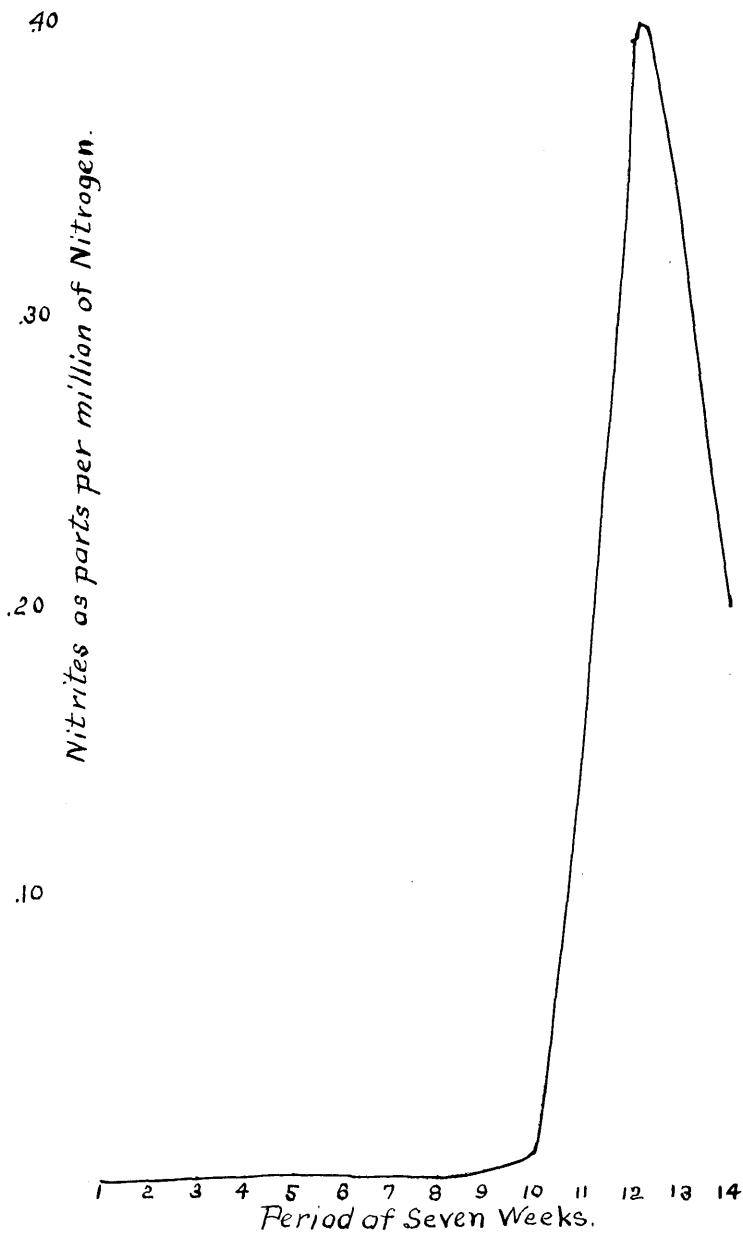

Plot VII.
Chemical Analysis — Nitrates.

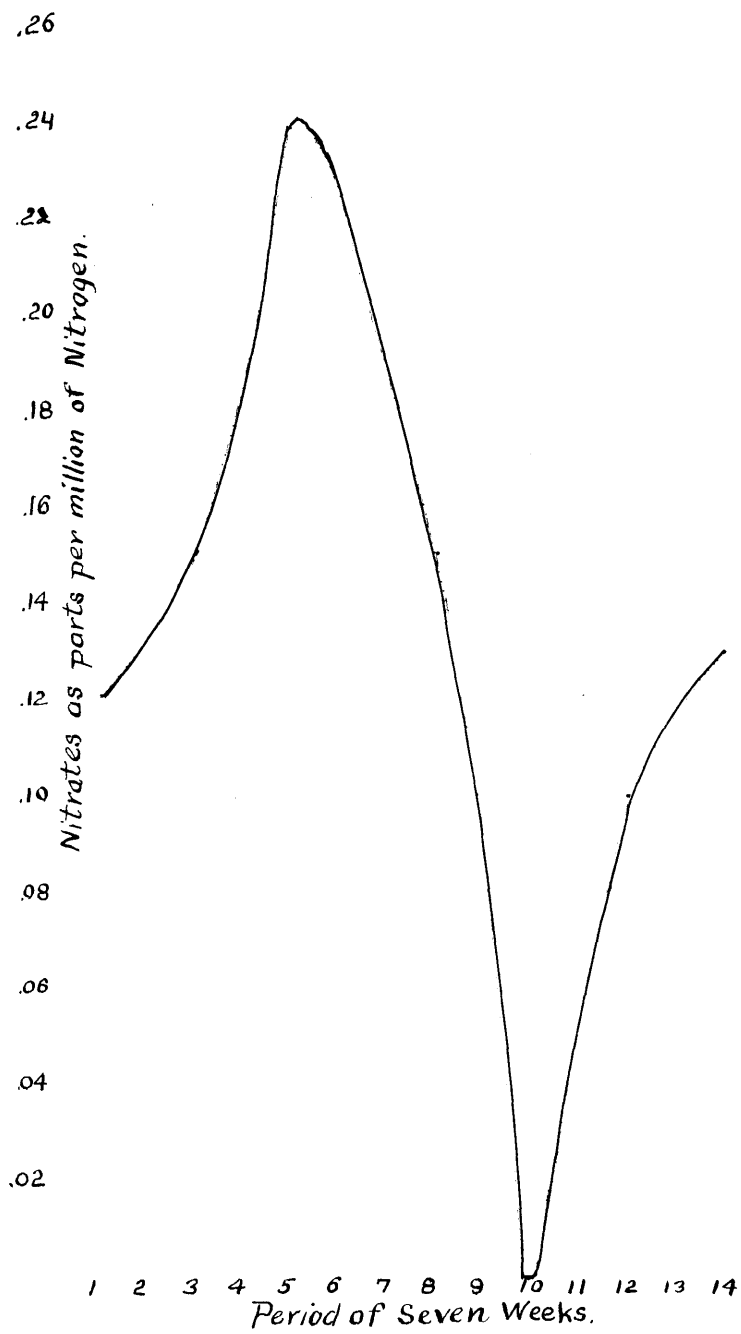

Plot VIII
Chemical Analysis — Oxygen Consumed.

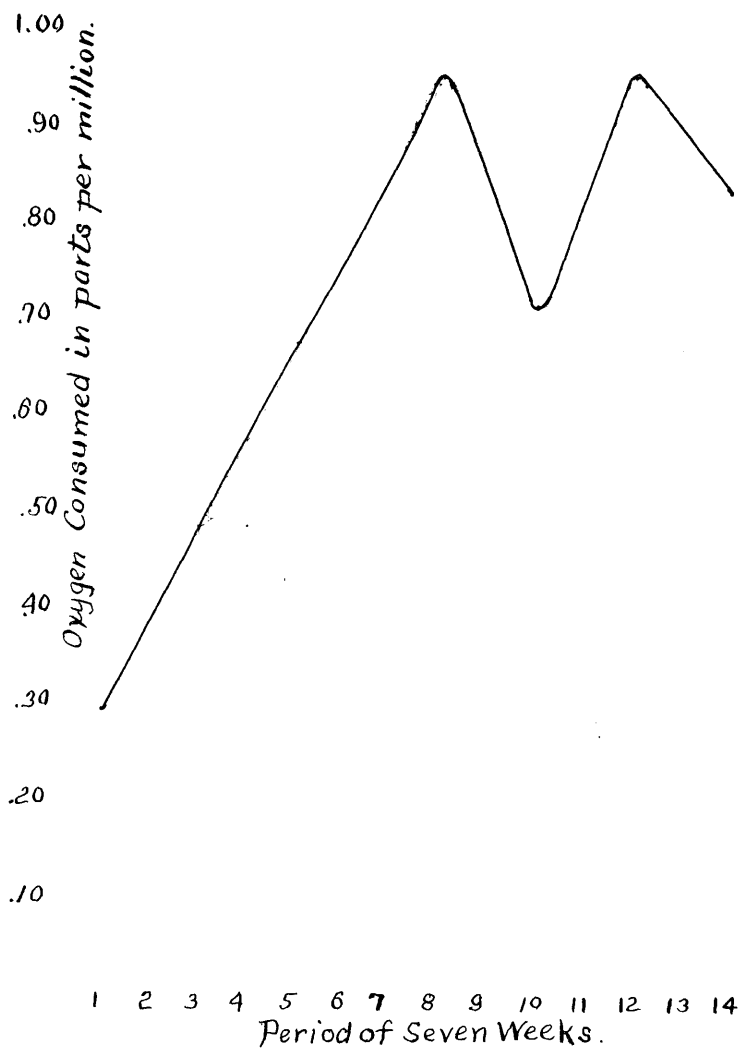

Plot IX.
Relation of Nitrites to Bacteria on Nutrient Agar-Agar.

If B = Number of Bacteria per c.c
and N = Nitrites in parts per million of Nitrogen
then $B = N \times 1,000,000$.

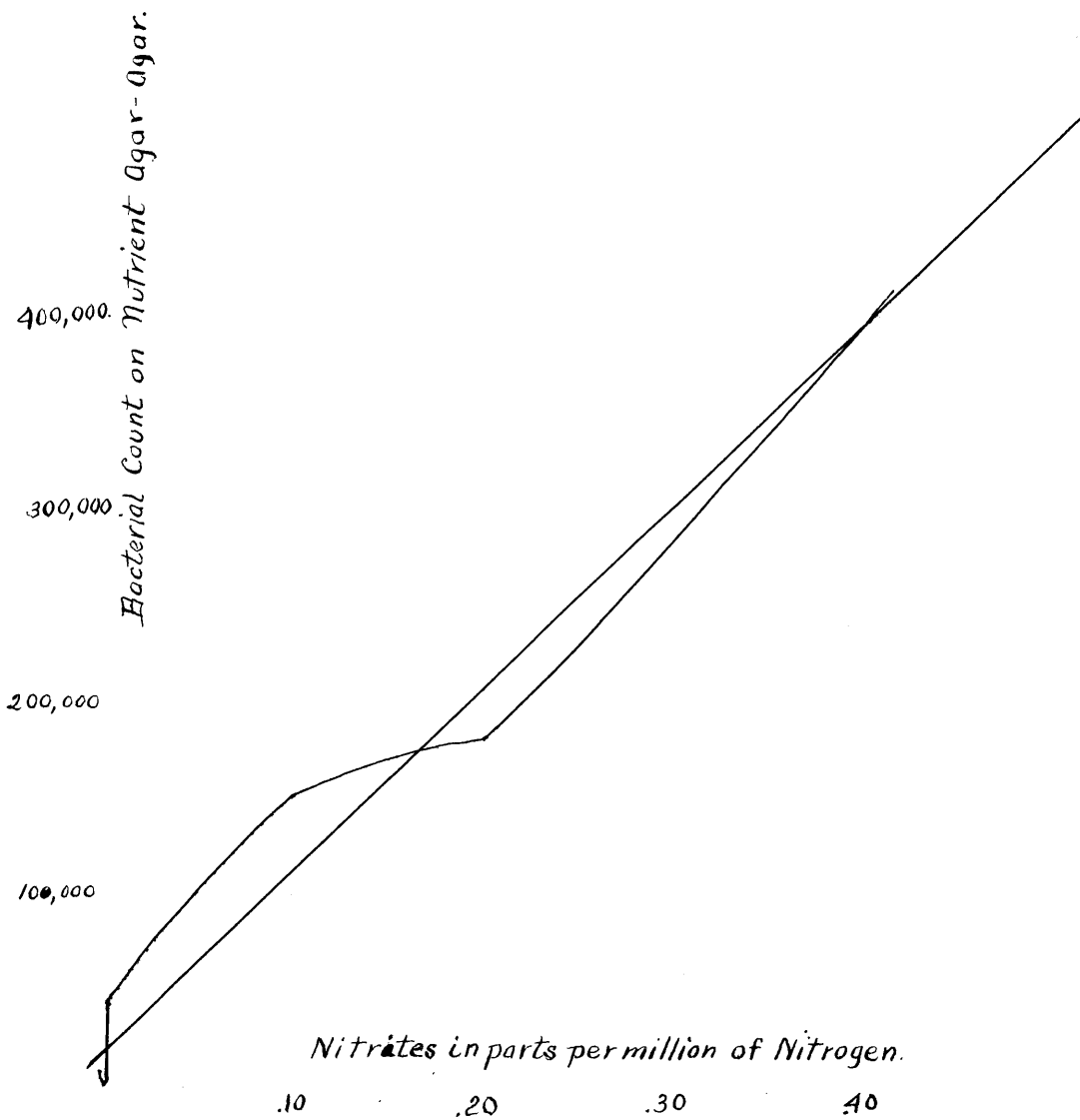

Plot X
Relation of Free Ammonia to B. Coli

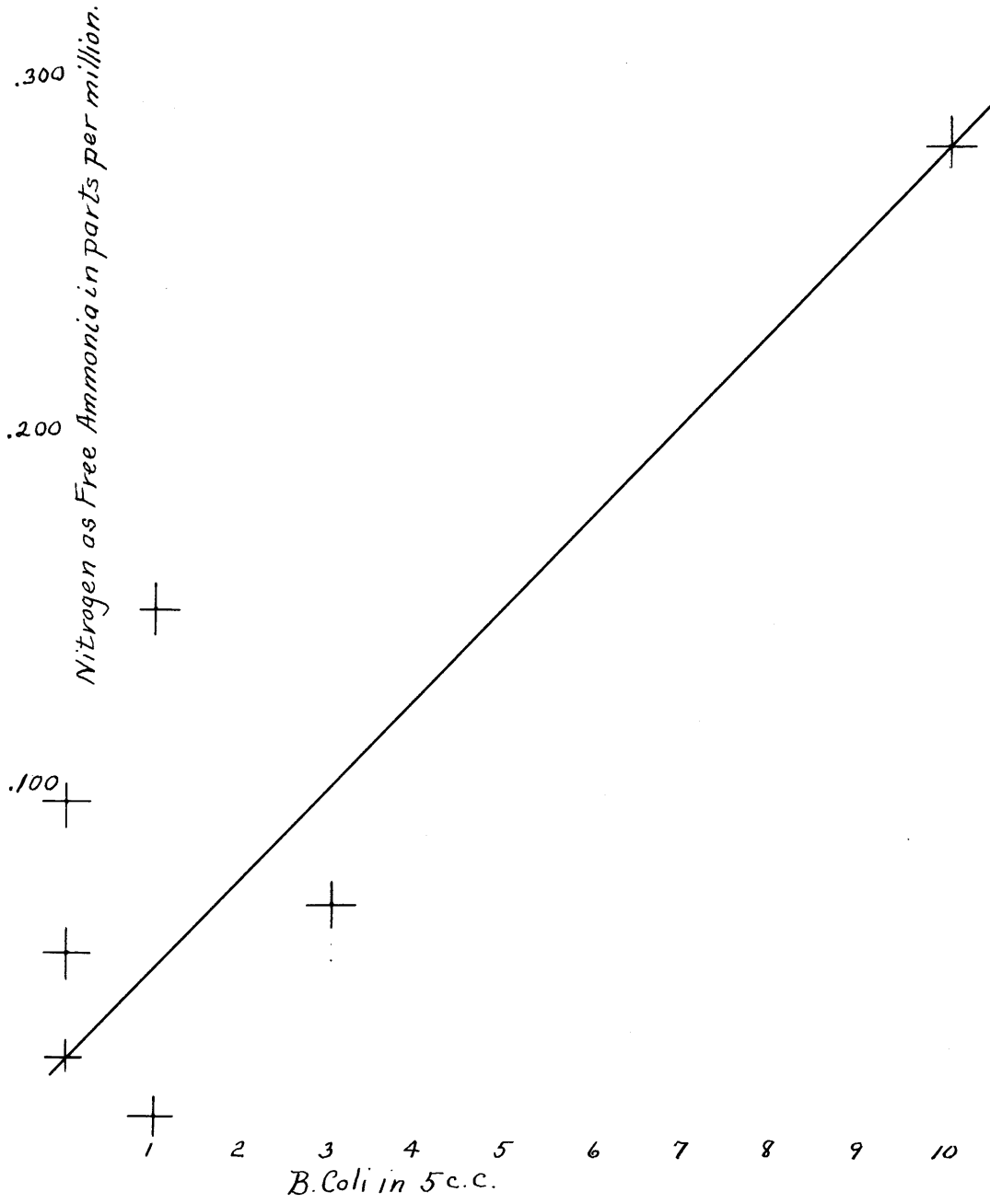

During the seven weeks of the test special notice was taken of the physical condition of the water in the pool and of the bottom and sides of the pool. At the end of the seven weeks the water was in just as perfect physical condition as when the tests were started, also the sides and bottom of the pool were in good clean condition. No color or odor was noticeable, nor was there any hair, sediment, or dirt of any kind either in the water or on the pool itself. This shows that by the methods of filtration, purification, and cleaning which are in use at the Cambridge Y. M. C. A. a swimming pool and the water in it can be kept in perfect physical condition for an indefinite length of time.

At one time during the tests the water became somewhat dark in color and a sediment was noticed on the bottom of the tank. This sediment was of a flocculant and slimy nature very similar to an alum precipitate. On investigation this precipitate was found to come from an alum precipitation which was taking place after the water had passed through the filter. By reducing the quantity of alum from 25 pounds to 15 pounds per week, this trouble was done away with and the water soon regained its former clear condition. This sediment was entirely removed by the use of the suction pump.

The efficiency of the filter and heater in respect to removal of bacteria was then tested. Samples were taken

before the water entered the filter, between the filter and the heater, and after the water had passed through both the filter and the heater. These samples of water were analyzed by the same bacteriological methods that were used in examining the pool water.

The following table shows the data that were obtained from the results of the analyses. Of course it must be taken into consideration that the heater is in operation only when the tank water falls below a temperature of 76°F, or 24°C.

Efficiency of the Filter and Heater.

Sample before entering filter.

	Bacteria per c.c.
Lactose Agar at 37°C.	330,000
Red Colonies (Acid to Litmus)	12
Nutrient Agar-Agar at 20°C	454,000

Samples after filter and before heater.

	Bacteria per c.c.
Lactose Agar at 37°C	75,000
Red Colonies (Acid to Litmus)	5
Nutrient Agar-Agar at 20°C	88,000

Sample after both filter and heater.

	Bacteria per c.c.
Lactose Agar at 37°	1200
Red Colonies (Acid to Litmus)	0
Nutrient Agar - Agar at 20°C	2700

The percentage removal of bacteria by the filter as calculated from the data is 80 per cent. The percentage removal of bacteria by the heater is also 80 per cent. The temperature of the water leaving the heater was 80°C, or above the thermal deathpoint of a number of types of bacteria. The total efficiency of the filter and heater when used in series for the purpose of bacterial removal is 99.5 per cent, which is an extremely satisfactory removal of bacteria.

Summary.

1. Swimming Pool water can be kept in good physical condition for an indefinite length of time by the use of filtration and purification.
2. The total number of bacteria can be kept low for some length of time by the use of hypochlorite of lime. At the end of that time certain bacteria, very resistant to hypochlorite, develop in considerable numbers.
3. The total number of bacteria should not be allowed to become too large as pathogenic types could exist undetected in the presence of a large number of bacteria.
4. Nitrogen as nitrites is a good index of the total number of bacteria and hence an index of the total contamination.
5. Nitrogen as free ammonia is a good index of the number of intestinal organisms present in the water.

The work recorded in this thesis was carried out under the direction of Dr. J. F. Norton, and I wish to express my gratitude for his interest and assistance. I also wish to thank the management of the Cambridge Y. M. C. A. for their kindness and interest, by which this work was made possible.

Bibliography.

- Alexander: Sci. Am. Supp. 1909, p. 1765.
- Angel: Proc. Incorp. Ass. Munic and Co. Engin. 1908, 34, p. 96.
- Atkins: Ill. Water Supp. Ass. Feb. 1911, p. 72.
- Bunker: Amm. Jour. Pub. Hyg. 1910., 20 No. 4.
- Baginsky: Hyg. Rundschau. 1896, 6, p. 597.
- Bassin: Sanitätsberichte über die Kgl. Preuss. Armee 1896-97.
- Burrage: Prs. Ind. Acad. Sci. 1909, 25th. Anniversary.
- Cobb: Boston Med. and Surg. Jour. 1908, Vol. 159, p. 9.
- Drescher: Sanitätsberichte über die Kgl. Preusse Armee. 1898-99.
- Edel: Arch. f. Hyg. 1893, 19, p. 225.
- Hanger: Comm. Labor Bull. 1904, 54, p. 1245.
- Hartog: Sanitätsberichte über die Kgl. Preuss. Armee. 1897-98.
- Hertzka: Monatsschr. f Geburt. u. Gynakologie. 1902, 16, Heft 3.
- Hesse: Zeit. f Hyg. 1897, 25, p. 482.
- Hilsum: Cent. f. Bact. 1900, Abt. 1, 27, p. 661.
- Jäger: Zeit. f. Hyg. 1892, 12, p. 525.
- Kirchner: Deutsche militärärztt. Wochenschr. 1888, 17, Heft 5.
- Klein and Schütz: Wiener med. Wochenschr. 1898, No. 6, p. 238.
- Koslick: Hyg. Rundschau. 1898. 8, p. 361.
- Lenhartz: Munch. med. Wochenschr. 1892, 21, p. 898.
- Lewis: Eng. News 1911, Vol. 65, p. 689.
- Mair: Pro. Roy. Soc. Med. 1908-9, Vol. 2, pt. 2, p. 227.
- Pfuhl: Deutsche, Militärärztt. Wochenschr. 1888, 17, Heft. 9.

- Schäfer: Deutsche, Militärärztl. Wochenschr. 1888, 17, Heft. 5.
- Schulz: Berlin klin. Wochenschr. 1899, 36, No. 39.
- Selter: Hyg. Rundschau. 1908, 18, p. 1381.
- Skutsch: Cent. f. Bact. 1892, 12, 309.
- Sticker: Zeit. f. Geb. u. Gyn. 1901, 45, p. 510.
- Stokes: Am. Med. 1905, Vol. 10, No. 26, p. 1075.
- Witte: Sanitätsberichte über die Kgl. Preuss. Armee. 1898/99.