

A Business Plan for iXa Walker

By

Stephen A. Morton

And

Geng Tan

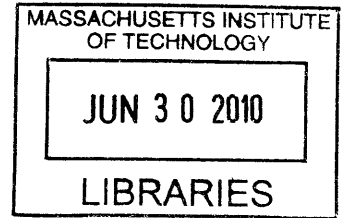

Submitted to the Department of Mechanical Engineering in
Partial Fulfillment of the Requirements for the Degree of

Bachelor of Science in Mechanical Engineering

At the

Massachusetts Institute of Technology

ARCHIVES

June 2010

© 2010 Stephen A. Morton and Geng Tan. All rights reserved.

The authors hereby grant to MIT permission to reproduce and to distribute publicly
paper and electronic copies of this thesis document in whole or in part in any
medium now known or hereafter created.

Signatures of Author

Handwritten signatures of Stephen A. Morton and Geng Tan, written over a horizontal line.

Department of Mechanical Engineering

May 10, 2010

Certified by _____

Maria C. Yang, PhD

Robert N. Noyce Assistant Professor of Mechanical Engineering and Engineering
Systems

Thesis Supervisor

Accepted by _____

Handwritten signature of John H. Lienhard V, written over a horizontal line.

John H. Lienhard V

Collins Professor of Mechanical Engineering
Chairman, Undergraduate Thesis Committee

A Business Plan for iXa Walker

By

Geng Tan

And

Stephen A. Morton

Submitted to the Department of Mechanical Engineering in
Partial Fulfillment of the Requirements for the Degree of

Bachelor of Science in Mechanical Engineering

At the

Massachusetts Institute of Technology

June 2010

© 2010 Geng Tan and Stephen A. Morton. All rights reserved.

The authors hereby grant to MIT permission to reproduce and to distribute publicly
paper and electronic copies of this thesis document in whole or in part in any
medium now known or hereafter created.

Signatures of Authors

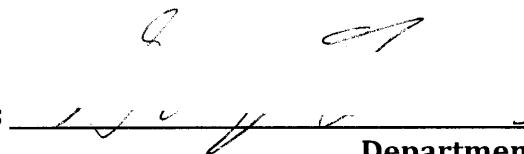

Department of Mechanical Engineering
May 10, 2010

Certified by _____

Robert N. Noyce Assistant Professor of Mechanical Engineering and Engineering
Systems
Thesis Supervisor

Maria C. Yang, PhD

Accepted by _____



John H. Lienhard V
Collins Professor of Mechanical Engineering
Chairman, Undergraduate Thesis Committee

A BUSINESS PLAN FOR iXa WALKER

By

STEPHEN A. MORTON AND GENG TAN

Submitted to the Department of Mechanical Engineering
on May 10, 2010 in partial fulfillment of the
requirements for the degree of Bachelor of Science in
Mechanical Engineering

ABSTRACT

A market study was performed to determine the feasibility of the iXa Walker. The walker industry is about to enter a large growth due to the entry of millions of baby boomers into the durable medical equipment market. Using data from the United States Census, the industry databases Hoovers and Frost and Sullivan, and market interviews we determined the market potential for the iXa Walker and drafted recommendations for bringing the product to market.

We recommend a limited initial launch of the product to a test market consisting of Boston area nursing home patients in order to gather feedback on the product's capability as a geriatric walker. This should be followed by a launch in local retail stores and a low cost marketing campaign aimed at generating buzz for the product and educating potential users of its capabilities. After two years the iXa walker should be marketed more aggressively to a national audience.

At a price of \$240 we predict a profit margin of 38% and a gross margin of 52% by the fifth year of sales. In the fifth year we expect revenues of \$193 thousand and that the product will become marketable by the third year of sales.

Thesis Supervisor: Maria C. Yang, PhD

Title: Robert N. Noyce Assistant Professor of Mechanical Engineering and Engineering Systems

Table of Contents

	Page
1. Executive Summary	5
2. Company	6
2.1. Company History	6
2.2. Company Ownership	6
3. Product	7
3.1. Product Overview	7
3.2. Addressed Needs	8
3.3. Innovation	9
3.3.1. Concept Design	9
3.3.2. Human Factors	10
3.3.3. Mechanical Joint Design	10
3.4. Work to Date	11
3.5. Competitive Landscape	12
4. Market Analysis	15
4.1. Target User Segmentation	15
4.1.1. Target Purchaser	15
4.1.2. Projected number of Users	15
4.1.3. Growth of Market	16
4.2. Industry Research	16
4.2.1. Manufacturers	17
4.2.2. Retailers	17
4.2.3. Elderly	18
4.2.4. Doctors	18
4.2.5. Insurance Provider	19
4.2.6. Summary of Industry Research	19
5. Strategy and Implementation	21
5.1. Patenting Competitive Advantage	21
5.2. Partnership with Existing Manufacturers	22
5.3. Pricing	22
5.4. Marketing Campaign	22
5.4.1. Initial/Test Marketing	23
5.4.2. Marketing through the Media	24
5.4.3. Marketing through Retailers	25
5.4.4. Marketing through the Internet	25
5.4.5. Marketing through Caregivers	25
5.4.6. Radio and Television advertising	25
5.5. Sales and Distribution	26
6. Financial Plans	28

6.1. Income Statement	28
6.2. Balance Sheet	29
6.3. Cash Flow	30
7. Conclusion	31
8. Acknowledgements	32

1. Executive Summary

iXa Walker is an aesthetically pleasing, innovative walking aid that can also help users stand up from a seated position. We developed it in as part of a team of 15 students in a Product Development Processes class at MIT. Since the iXa was ranked “most likely to succeed in market” in class, we have decided to look into its market potential.

There are 2 million walker users in the U.S. and we would like to develop a national market. We will do this by pilot launching our product in Boston and increasing our market area to a national scale over time. Throughout the course of product development, we have been able to make valuable connections with local retailers and user communities and to gain insights into the local market. Once we establish a presence in Boston, we can expand our sales through launch of a website.

In moving forward with this project, we believe that our first priority is to obtain the proper intellectual property protection of our product and company and to partner with one of the existing walker manufacturers. Legal documentations, such as the patent and licensing agreement are going to be vital in protecting ourselves. Because the landscape of healthcare related products is extremely difficult to navigate, it will be key for us to partner with a large, established, resourceful manufacturer.

Before making iXa walker available in stores, we will take advantage of our relationships with local nursing homes to establish them as a test market. Once we have confirmed the performance of the iXa Walker in test markets we will launch retail sales and begin an awareness campaign directed to walker users in the greater Boston area. Initial marketing will be achieved through press releases to local news sources; the establishment of a presence on the internet; direct contact with local geriatric doctors and caregivers; and in store advertising.

Initially, we will endure expenses of \$21 thousand. This will include recurring expenses of \$2 thousand for advertising and \$9 thousand for administrative expenses and two onetime expenses of \$10 thousand in the first and third years of operation. We expect marketing expenses to increase by \$2 thousand in our third year of operation, which is when we will launch a national internet advertising campaign to attract more sales. At a price of \$240 and production cost of \$70 we predict that iXa Walker will be able to capture 14 percent of local sales within 5 years and that it will be profitable in 3 years.

2. Company

2.1 Company History

The iXa walker was conceived in 2009 as the senior design project for the purple team in MIT's mechanical engineering senior product design class. The members of the Purple team were seniors in Mechanical Engineering at the Massachusetts Institute of Technology. When presented with the challenge of designing a medical device, team members identified the need for people with leg strength and stability issues to be assisted when rising from chairs and sofas.

These people often have to either wait for someone to help them rise from the seat or grab onto objects near the seat in order to get up, which is inconvenient and very dangerous. Team members identified the orthopedic walker as a device that many people with these strength and stability issues use and we sought to design a modified walker that would assist users when rising from a chair. Over the course of the term team members designed and tested several orthopedic walker designs. When the alpha prototype was revealed at the final presentations for the course it received very positive reviews. The iXa Walker group was formed to continue development of the iXa Walker, which will provide the elderly with increased independence and a fashionable walker that doesn't scream "medical device."

2.2 Company Ownership

iXa Walker will be formed as a limited liability company. Company ownership is currently divided evenly among the original team's 15 members. As the product is developed, shares will be distributed to continuing team members according to the amount of work that they perform and any milestones that they achieve in the development of the walker, such as securing funding, filing the patent application, and other tasks. These "shares" help determine each person's equity in the company. Furthermore, with the consent of the existing owners, additional shares can be made and exchanged with resources and contribution from a third party

3. Product

3.1 Product overview

iXa Walker(**Figure 1**) is an aesthetically pleasing, innovative walking aid that can also help the user get up from a seat. The primary walker users are elderly persons with muscle weakness. When getting up from a seated position, these people often grab whatever is within their reach to give them extra support. It is a dangerous process, often leading to falls and injuries and their inability to freely get up from seats severely limits their lifestyle.



Figure 1. iXa Walker
Aesthetically pleasing,
innovative walking aid

iXa Walker helps these people in two ways. First, it is an aesthetically pleasing, fully functional walker. Visual appeal is important because the users don't like their walking aids to scream "medical devices for the disabled." Second, it can transition from "walking position" to "kneeling position," providing extra support when the users stand up (**Figure 2**).

iXa Walker helps elderly citizen walk, safely get up from a seating position, and retain a sense of independence and health. We developed an alpha prototype through 2.009, the Product Design Process class with the help of physical therapists, nursing specialists, and senior walker users from nearby communities, such as Somerville Home and Visiting Nurse Senior Living Community. Our prototype has shown tremendous promise in field testing, and eventually, we plan to work with durable medical equipment manufacturers, such as Medline to deploy iXa Walker in areas beyond Boston.

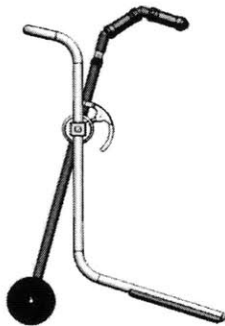

Figure 2a. Walking Position
Fully functional walker

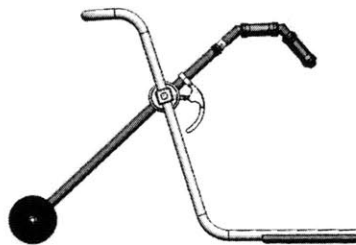

Figure 2b. Sitting Position
Aid individuals getting up

3.2 Addressed Needs

Currently, when getting up from a seat or a bed, walker users often grab whatever is within their reach to give them the extra support they need to stand. This is a dangerous practice that often leads to falls and injuries.

These people are often embarrassed to ask for help for the petty labor of standing up. They do not want to have to wait for help, and they do not want to bother their nurses, friends, relatives, or children. They do not want to feel that their life style is at the mercy of other individuals, and they want to retain their sense of independence, even it means they have to take potentially dangerous actions.

In our studies, we asked an elderly woman what she would do if she sat on a chair and couldn't get back up. She responded that she would slowly slide from the chair down to the floor, crawl to the nearest furniture, and grab it to help her stand up. She told us that she "would do that, because that takes 10 seconds, but asking someone else is embarrassing and you don't know when they can actually help you."

In other instances, we saw elderly citizens pull nearby furniture towards them as leverage, pull on their walkers and use the tipped walker to help them get up, or rock back and forth on a couch so they can gain enough momentum to get up. All of these practices are dangerous and they contribute to the 47,000 fall injuries related to walkers or canes each year¹.

Finally, in our interview with Toby Watterson, general manager from Somerville Visiting Nurse Assisted Living Community, he told us that a few residents "are on the verge of moving to a nursing home just because they can't really get up by themselves."

We would like to solve this problem.

¹ US Department of Health and Human Services. 47,000 Older Adults Treated in Emergency Departments Annually for Fall Injuries Related to Walkers and Canes. CDC Online Newsroom, June 2009 (Accessed May 10, 2010). <http://www.cdc.gov/media/pressrel/2009/r090629.htm>



Figure 3. Nursing home patient receiving aid

3.3 Innovation

3.3.1 Concept Design

The iXa Walker is designed for use in two positions: a standing position and a kneeling position. In the “kneeling position” its top handles are designed to mimic the arm rails on a chair. Multiple physical therapists have told us in interviews, “for people with muscle weakness, the proper way of gaining more support while trying to get up is to vertically push down on a hard surface such as arm rests.” Several senior citizens have also told us that they do not choose to sit on chairs that have no arm rests because they need them to get up, and that they do not sit on surfaces too soft because they cannot push down on soft surfaces. Finally many nurses have told us that they purchase hard chairs with arm rails for the nursing homes because those chairs are the easiest for the elderly citizens to get up from. By kneeling into a lowered position the iXa Walker provides a hard surface for users to push on when standing up from a seat.

In the “kneeling position” of the iXa Walker, its top handles are positioned like arm rails (Figure 4), allowing the user to properly and safely get up from the seat. Unlike existing solutions to this problem, iXa Walker does not require power, does not add any more bags for the person to carry, and does not require the assistance of other individuals. It is a mobile, standalone solution to this problem, and there is nothing out there that is like the iXa Walker.

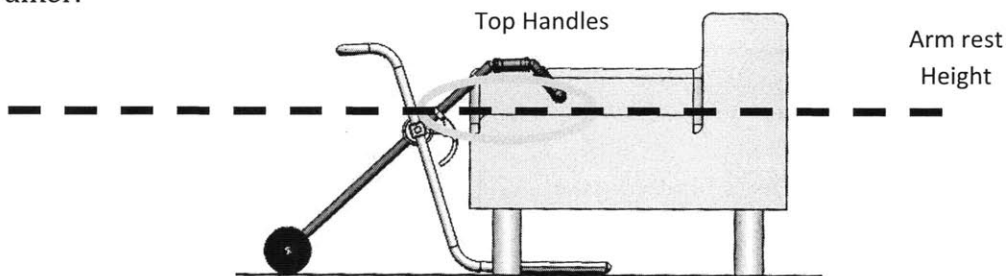

Figure 4. iXa Walker’s top handles mimic the armrests of chairs

In its “standing position,” the iXa Walker functions like a standard two wheeled walker. Its front wheels are large enough to roll over small gaps and humps in floors and its back legs are at an angle, which allow them to slide over these same obstacles. Additionally, the back legs sit on top of a low friction material that allows them to slide over various floor surfaces without the use of tennis balls, which are commonly used to reduce friction on the feet of standard walkers.

3.3.2 Human Factors

In order to accommodate the different positions of the walker, the top handles are specially designed into two sections to encourage proper use. We have also designed our middle handles to be used even by people with arthritis in their finger joints. In addition, we have attached wheels in front of the walker to make it easy to push but left wheels out in the rear legs in order to provide a firm support. In order to encourage use by the elderly, we have also designed the iXa Walker to be in different colors, making them look much less like medical devices. These are features not considered by most existing walkers.

3.3.3 Mechanical Joint Design

Our iXa Walker features a novel joint mechanism that allows it to safely transition between the two modes. (**Figure 5**)

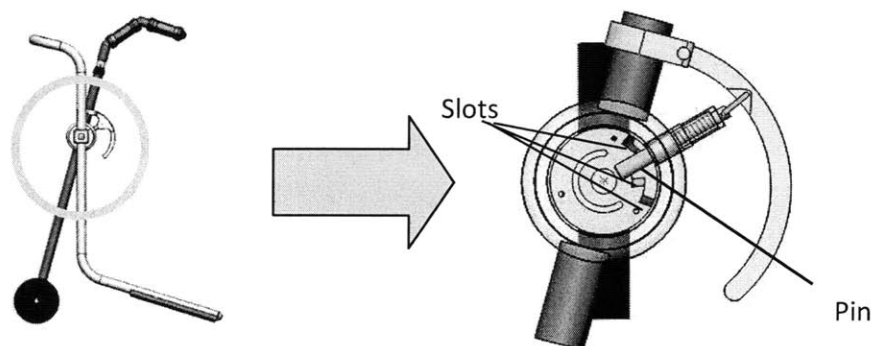

Figure 5. Slot and pin mechanism in the joint of iXa Walker

The joint has a slot and pin mechanism built into it. The user can pull on the middle handles that are attached to the pins, and the walker will be free to kneel. The user can then slowly let the top handles come down to their resting positions. Finally, the walker is in the “kneeling position” ready to give the person the solid surface he or she needs (**Figure 6**).

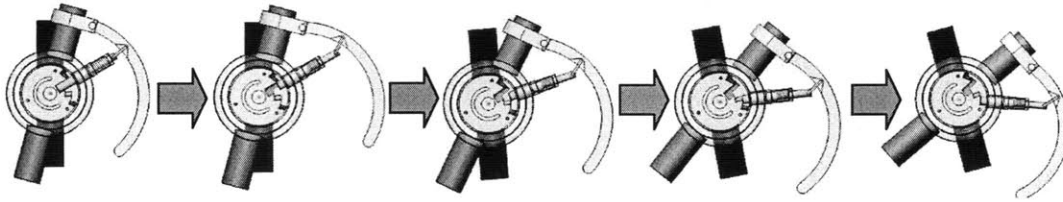

Figure 6. Slot and pin mechanism in the process of lowering the top handle

On the way up from the “sitting position” to the “standing position,” the person can simply lift the top handles of the walker. Because the pins are spring loaded, they will automatically be pushed into its appropriate slots in the process. Finally, for a safety measure, we have included a middle slot level. If the user lets go of the walker handles while trying to raise the walker to a standing position, the top handles will not fall all of the way down. The pins will be stopped at the middle safety slot as shown in **Figure 7**.

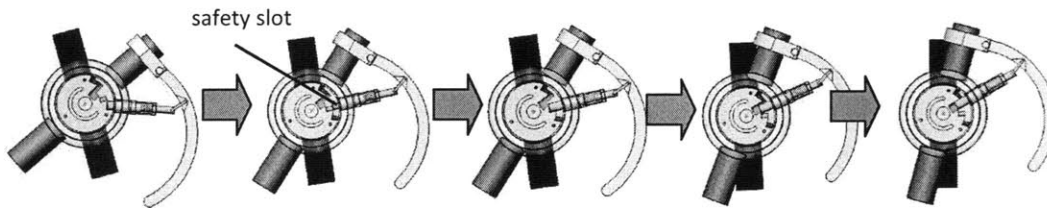

Figure 7. Slot and pin mechanism in the process of raising the top handle

3.4 Work to Date



Figure 8a. Walking position



Figure 8b. Sitting position

We have developed an alpha prototype through our 2.009 class last term (**Figure 8**), and it was rated “most likely to succeed in market” by audiences at the final presentation. Since then we have made some additional progress. Geng and I have been developing a business plan for iXa Walker as our thesis and it will be completed by May 7th. Eric Beecher and his colleagues have decided to work on a redesign of the iXa Walker as their thesis, and they will have an improved design for iXa Walker by May 7th. We have been working closely with each other for the past 7 months and we have developed a great rapport with each

other. Furthermore, we have begun mentoring with the MIT Venture Mentoring Service so we can develop iXa Walker into a self-sustaining venture.

3.5 Competitive Landscape

Our product takes a unique approach to solving a common problem that has gone unaddressed for years. In the process, we expect to compete with the existing walkers, rollators, and other assistive devices. In this section, we will briefly introduce the existing products and highlight our key differences.

Walkers: Many walkers exist, but they all look similar (**Figure 9**) and usually cost less than \$100. Wheels and other accessories can easily be attached to the walker. This is a highly commoditized product, and customers are slowly moving away from these products due to their “medical looks.” The cost of the walker can be almost entirely covered by insurance.

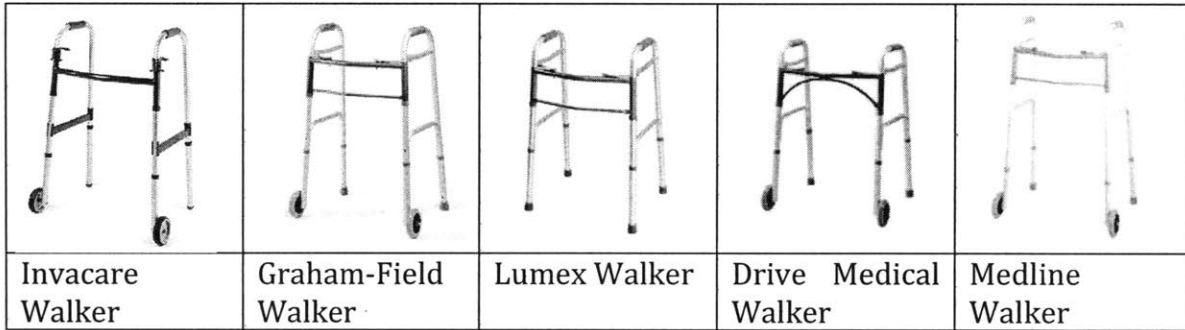

Figure 9. Examples of standard geriatric walkers

Rollators: Many rollators exist as well, and there are still very few differences that exist from one to another. They are typically more colorful compared to regular walkers, come with a seat and baskets, and are dubbed as the “Cadillac of walkers” due to their improved look from regular walkers (**Figure 10**). Many elderly purchase rollators even if they have to pay some extra cash out of their own pockets.

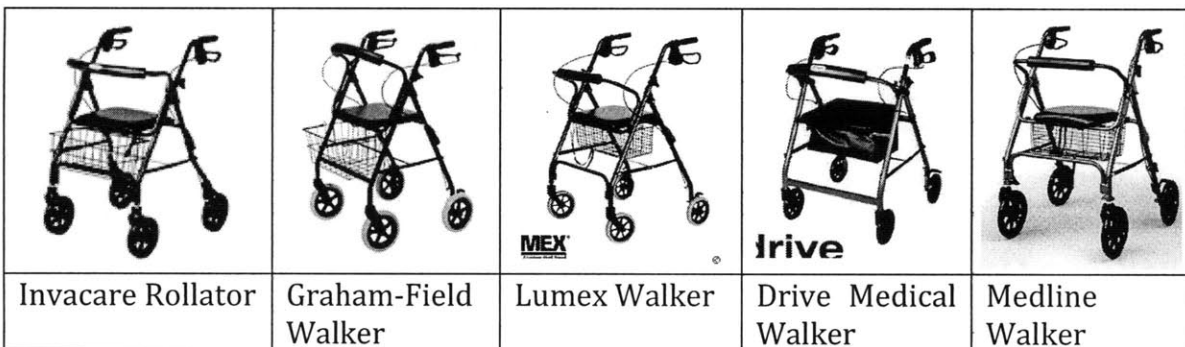

Figure 10. Examples of rollators

Other Assistive Devices: Many other assistive devices exist but they are typically too cumbersome to use, require electricity, and/or have limited portability (**Figure 11**). These solutions can range from 20 to a few thousand dollars.





				
Power Chair	Lift Chair	Electronic Seat Lift	Lifting Installation	Lifting devices

Figure 11. Examples of assisted standing devices

Unlike existing walkers, iXa walker aims to establish a new definition for casual looks in walkers (**Figure 12**). It is more aesthetically appealing than the existing walkers and offers the same level of assistance when walking. Furthermore, unlike existing solutions to this problem, iXa Walker does not require power, does not add any more bags for the person to carry, and does not require the assistance of other individuals (**Figure 13**). It is a mobile, standalone solution, and there is nothing out there that is like the iXa Walker.

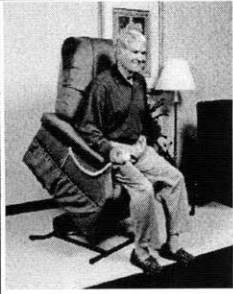
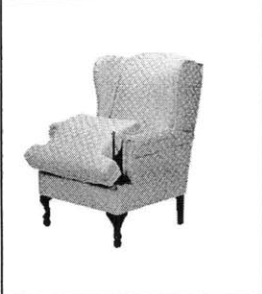
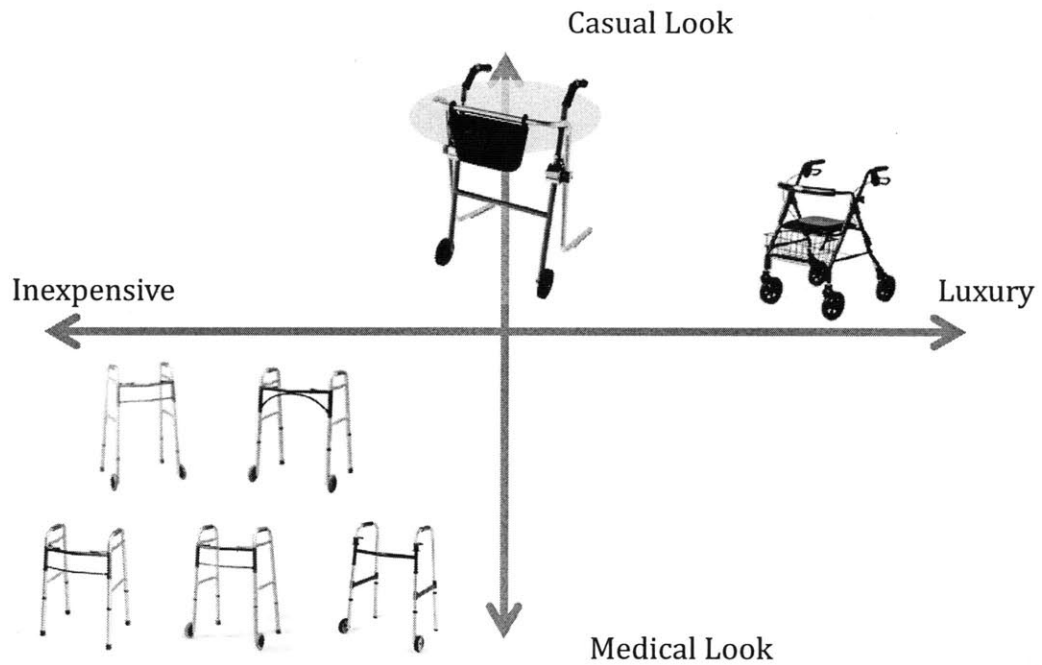

Figure 12. Perception map of product appearance

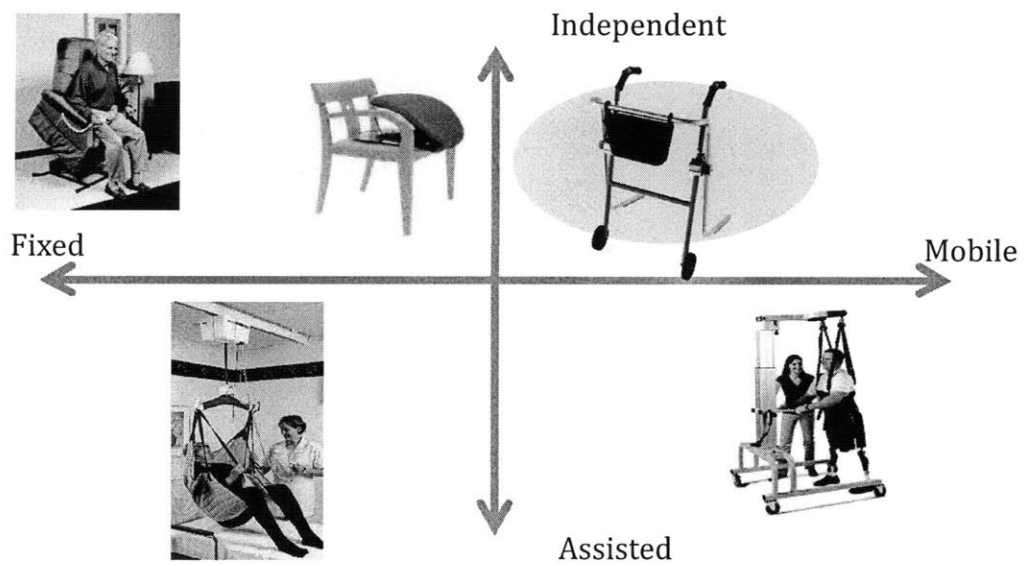

Figure 13. Perception map of functionality

4. Market Analysis

4.1 Target User Segmentation

The iXa Walker's target user is over the age of 65 and suffers from strength and stability issues in their lower extremities. The target user enjoys being free to move without assistance from others and not needing to be helped out of a chair and into a walker. The target user is also conscious of how a walker looks and would prefer an assistive device that is attractive and customizable. iXa Walker will begin by targeting users in the Boston area (**Figure 14.**), then expanding sales to a national market via online sales.

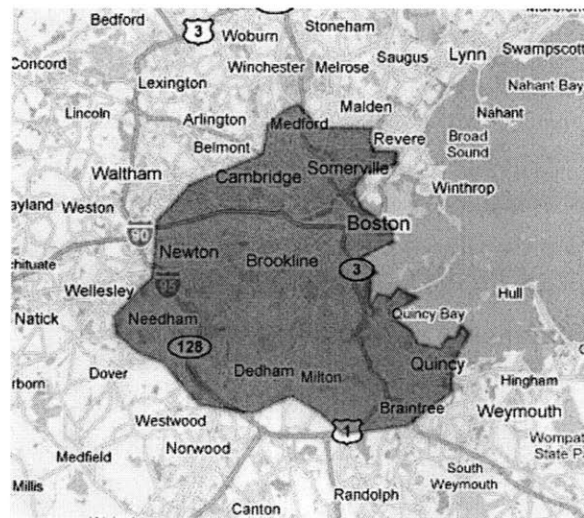

Figure 14. Initial Target Market Area

4.1.1. Target Purchaser

The primary buyer of the iXa Walker is the end user. Supplier interviews suggest that elderly walker users do not typically bring other people with them to help them buy walkers and that their relatives and friends rarely purchase their walkers for them. Because of this, we will be marketing directly to the users.

4.1.2 Projected Number of Users

According to the US Census², there are about 39 million elderly people in the US today. Our estimates, which are supported by Frost and Sullivan's U.S. Mobility Aid Markets report, put the number of walkers sold in the US at over 500 thousand each year. With 156 thousand elderly individuals in our target market area we estimate yearly sales to be about

² All population figures were obtained from U.S. Census data at www.census.gov

2,500 walkers per year. This is consistent with sales figures obtained from interviews with local retailers.

By our fifth year of operation we believe that we can capture about 15 percent of the local walker market, where we will have a physical presence in walker stores, and 0.08 percent of the national walker market, where sales will be conducted primarily over the internet. This would give us local sales of about 370 walkers per year and national sales of about 900 walkers per year. At a sales price of \$240 per walker we expect sales of \$193,000 in year 5.

We estimated local sales to be about double the sales of the most popular walkers on the market today. We believe that we will be able to achieve this high percentage of sales because our walker offers advantages that those walkers do not offer and we will actively market the iXa walker in local markets. This is not a common practice within the industry and it will gain us more exposure.

Our national sales estimates are low because we do not expect to have the resources available to us to initially market the iXa walker on a national scale and we expect a limited manufacturing capacity in the first five years as we prove our product.

4.1.3 Growth of Market

The number of elderly in the United States will increase rapidly with the entry of 76 million baby boomers into the 65 and over age group over the next 20 years. Data from Merck & Co³ suggests that there could be over 50 million people in the US over the age of 65 by 2020 and 80 million by 2040, up from 39 million in 2009. This will put walker sales at about 640 thousand in 2020 and over 1 million in 2040. Our market is growing rapidly and it will continue to do so for quite some time.

4.2 Industry Research

In conducting industry research, we interviewed several local retailers, including Belmont Medical Supply, Champa Apothacary, and Cambridge Medical Supply, and asked them about the dominant suppliers and customers' buying patterns. We found some key facts about the manufacturers, retailers and customers.

³ Merck & Co. U.S. Demographics. The Merck Manual of Geriatrics, September 2005 (Accessed March 24, 2010). <http://www.merck.com/mkgr/mmg/sec1/ch2/ch2b.jsp>

4.2.1. Manufacturers

There are two types of manufacturers. One type is the large, widely recognized brand name manufacturer, such as Invacare and Medline. They produce a wide variety of products, ranging from durable medical equipment to medical devices. They have a strong distribution network, and they usually ship a bundle of supplies to retailers. Because their revenues are driven by the sales across a variety of products, they often give bundle discounts for retailers to distribute multiple product lines. Furthermore, economy of scale from the large volume makes it easier for them to provide regular assistance to retailers. The second type of the manufacturers is the smaller manufacturers, such as Numex, who are primarily contractors for companies such as Invacare and Medline, providing low cost, high quality production service. Although they occasionally sell directly to retailer as well, their small, regional based operation often prevents them from offering adequate customer service to the retailers.

4.2.2. Retailers

There are very few retailers in this field, and wherever they are, they often hold monopoly in the local community. This is due to the limited mobility of the elderly citizens. Moreover, the retailers often have been in the business for more than ten years and they have strong ties to the community, including the medical communities nearby. Most of their customers have been referred to them by the doctors, and most of the customers come in with doctors' notes. It should also be noted that the smallest retailers lack the power to negotiate with the branded manufacturers due to their small capacity. **Figure 15** below shows the approximate area each retailer serves and their approximate annual volume sales. Of all the walkers sold, more than half are rollators. In launching our product, we need to contact each of these retailers separately, since they are subject to little influence by other retailers in the greater Boston area.

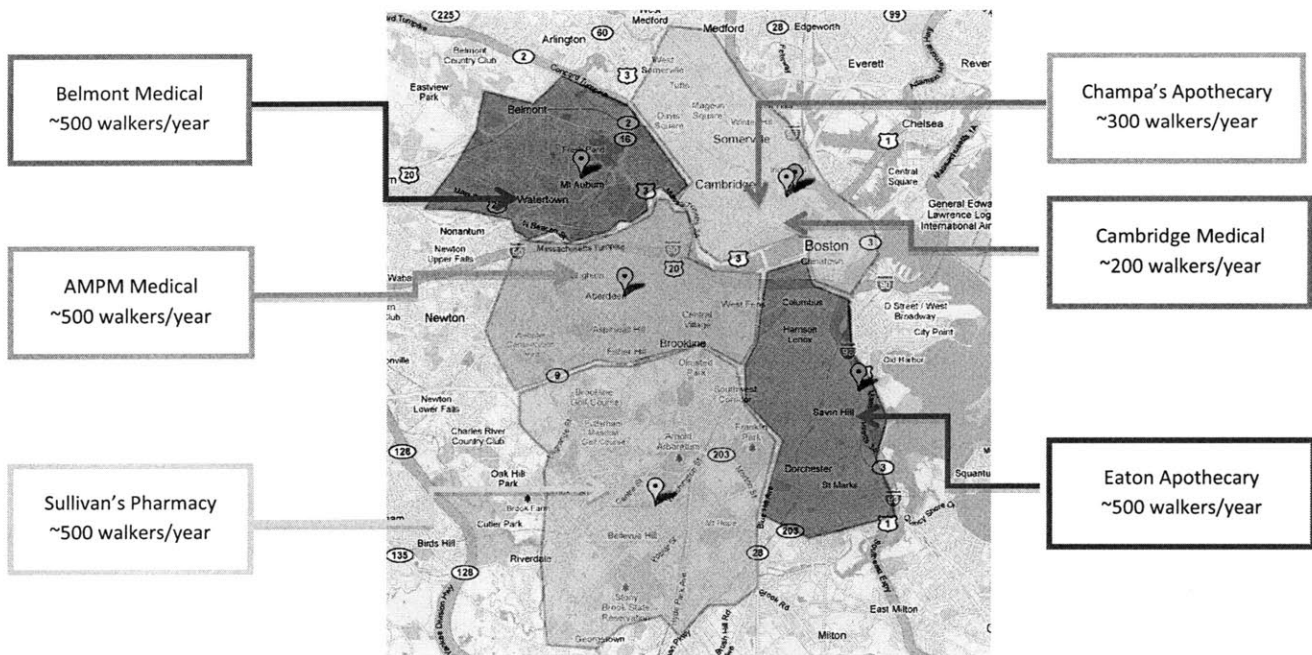

Figure 15. Walker retailer in Boston, each of their market, and their annual sales

4.2.3. Elderly

Walkers and rollators are usually purchased by the people who need them, and purchase by family members is rare. Walkers are also purchased by some nursing homes, although many residents have a walker before entering such institutions. Therefore, we will focus our energy on the bulk of the market, the elderly who live independently. When elderly individuals purchase a walker, they usually have little information regarding the product and they use their friends, doctors, and store clerk for reference. When they make a purchasing decision, they consider which products can be reimbursed by the insurance and how much do they need to pay out of their own pocket. Our research has revealed that seniors are willing to pay some extra money for a more expensive model, so long as the majority of the cost is covered by the insurance. We have also found that seniors compare their walker with their friends' and when one person within a group purchase a rollator, the rest of the group tend to follow the trend. This serves well for us since our walker is designed with the style conscious elderly in mind. It also means that if we successfully market our product to the leader of the pack within the community, the rest of the community will follow.

4.2.4. Doctors

Within this industry, doctors hold a peculiar role. Although they do not purchase the walker directly, they decide which retailer the patient should go to through referrals and they recommend which walker to use through prescription. However, the doctor's influence on which retailer the patient uses is much more significant than his or her

influence on which walker to buy, and the patient can often easily ask the doctor to amend the prescription from a regular walker to a rollator. Nevertheless, the doctor will never prescribe any product that is deemed unsafe. Thus, we also need to get doctors to acknowledge the effectiveness and reliability of our product

4.2.5. Insurance Provider

The last piece of this industry is the insurance provider. They help patients cover most of the cost associated with the walker purchase, and few patients will purchase a walker without having it be covered by his or her insurance. Our product needs to be approved by the insurance provider for reimbursement if we are to succeed.

4.2.6. Summary of Industry Research

From our research, we have concluded that we need to possess the following.

- 1). Partnership with brand manufacturer/distributor
- 2). Recognition by the retailers
- 3). Recognition by the opinion leaders within the elderly community
- 4). Recognition by the doctors for our safety and effectiveness
- 5). Recognition by the insurance company

We have also summarized our findings in the following chart, including some of the key incentives and questions for each party (**Figure 16.**).

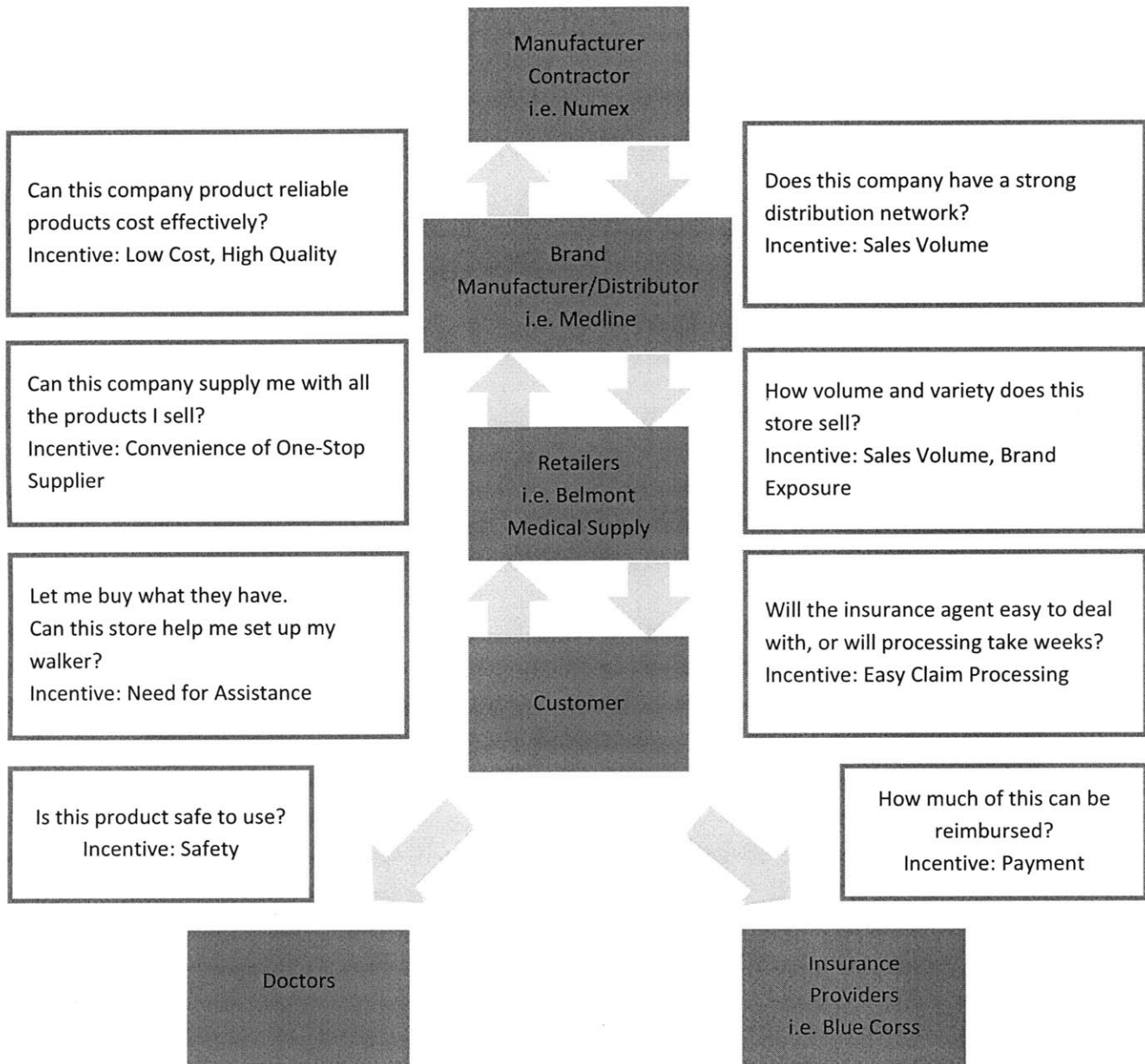

Figure 16. Stakeholders in the walker market and their key incentives

5 . Strategy and Implementation Summary

5.1 Patenting Competitive Advantage

The iXa Walker will be marketed as a lifestyle product that returns users their independence. It is an aesthetically pleasing mobility aid that not only helps its users to walk, but also helps them to safely get off of chairs, sofas, and toilets without having to wait for assistance from caretakers. Unlike existing products, such as lift chairs, toilet rails, and lifting cushions, iXa Walker is an independent, safe, aesthetically pleasing solution.



The iXa Walker accomplishes this by kneeling to a position that places arm supports next to the user's hips when seated. The user can then use those supports to stand up and return the walker to its upright position. In the upright position the iXa walker functions like a standard two-wheeled walker. Users will enjoy a more attractive walker that doesn't make them look or feel like medical patients.



Figure 18. iXa walker prototype in kneeling position

In the first year of operation, we will spend \$10,000 in legal counsel to secure patents protecting our competitive advantage. Existing competitors are large durable medical equipment companies that can easily develop a similar product, and we need to protect ourselves. In addition, securing the patent will give us more leverage in partnering with existing players in the future.

5.2 Partnership with Existing Manufacturers

Since the existing manufacturers possess the distribution network and legal resources to navigate the landscape of durable medical equipment market, we will be seeking to partner with one of the large existing manufacturers in launching iXa Walker. After patenting, we will create marketing materials, such as additional prototypes and demonstration videos, so we may use them to approach existing manufacturers.

5.3 Pricing

We estimate that each iXa walker will cost about \$80 to produce. We will price the iXa walker between \$190 and \$240, which is in the range of a high end rollator (**Figure 19.**). It is also comparable to the combined cost of a basic walker or rollator, one chair lift, and a set of toilet rails, all of which it would likely replace. By pricing the iXa Walker in this range we can expect a profit margin of 38 percent and gross margin of 52 percent in our fifth year of operation.

iXa Walker	Walker, Lift Cushion, Toilet Rails	Rollator, Lift Cushion, Toilet Rails
\$240	\$170	\$210

Figure 19. Prices of iXa Walker and competitive devices

The iXa walker will be classified as “Durable Medical Equipment” and will be eligible for Medicare coverage. Medicare coverage will offset most of the cost of a walker.

5.4 Marketing Campaign

Since the iXa walker is a new product, marketing for the walker will focus on an awareness campaign to educate the public about the existence and benefits of the iXa Walker. In order to maintain low advertising costs we will take advantage of many opportunities for free or cheap marketing through non-traditional channels. The goal of early marketing will be twofold:

- 1) Introduce the iXa Walker and the benefits of its use to the public
- 2) Generate buzz and word of mouth marketing

Marketing will include details on the walker given through press releases to the media and websites such as youtube.com and iXawalker.com. More traditional marketing through radio and print ads will be avoided early on in order to minimize costs.

5.4.1 Initial/Test Marketing

Initial marketing will be aimed at nursing home residents in the Boston area. Interviews with nursing home patients and observations in nursing homes suggest that if one person in a nursing home gets a new walker or rollator and likes it then many people will follow. The high percentage of walker users in nursing home populations, sometimes as high as 40%, will give us a specific initial sales market to cater to, allowing us to focus marketing on a specific segment of the population and to experience a higher return on our initial marketing efforts. This smaller initial market will also give us a group of users that are easy to contact, from whom we can gather feedback on our products for possible improvements before we begin mass marketing.

Word of mouth marketing will be a powerful tool in nursing homes and assisted living communities and we will take advantage of it by marketing to early adopters in Boston area communities and encouraging users to tell their friends about us. Since many nursing homes do not have internet access, these early users will be able to order an iXa walker using mail-in order forms attached to brochures (**Figure 20**) that describe the walker and its benefits to nursing home patients in detail, explain the customization options available, and allow potential users to order a walker to be delivered to the nursing home.

In nursing homes where brochure marketing is not effective we will give demonstrations and information sessions detailing the benefits of an iXa Walker over a standard walker or rollator.

Designed to meet your needs . . .

SAFETY

Specially engineered joint mechanism can support up to 300 lbs without instability.

Internal ratchet system provides continuous support throughout the rising process in the event of falls.

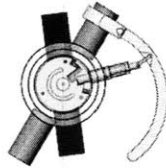

Ergonomically designed chassis helps users get up in a method recommended by medical professionals.

VERSATILITY

Highly graduated height adjustments allow you to pick the height you like best.

Tight turn radius and big wheels allow you to easily walk through small spaces and over obstacles.

Ergonomically designed handles makes everyday use of the walker comfortable.



Lightweight at only 10 pounds.

Folds easily and fits into the trunks and backseats of cars.

Two-wheel design creates a balance between support and mobility.

STYLE

Rich colors enhance its appeal.

Its intuitive design is sleek, modern, and fits your lifestyle.

Its compact size means you are still what everyone sees first, not your walker.



The Ixa Walker



The walker that lets you get up and get on with your life.

Figure 20. Sample nursing home brochure

5.4.2 Marketing Through the Media

Marketing to the general population will be initiated through print media in the form of newspaper and magazine articles. We will send press releases to area newspapers such as the Boston Globe and Boston Herald touting a new wave of innovation in the walker industry. The headlines and opening paragraphs for the articles will be geared toward attracting the attention of potential buyers and they will emphasize the company's MIT connections. Print and internet articles are an excellent source of free advertising and we plan to take advantage of them.

5.4.3 Marketing Through Retailers

It is also important for us to establish a strong presence in the locations that walkers are sold. Many walker users buy the best walker that they see when they enter a shop and don't go to the walker store looking for a specific brand or even style of walker. We will take advantage of this by providing store owners with a display walker and literature advertising the walkers. We will also educate store owners about the benefits of the walker. By maintaining a strong presence in stores that sell walkers we will make it more likely that consumers will notice and buy the iXa Walker. We expect marketing through retailers to cost us less than \$100 in material cost.

5.4.4 Marketing Through the Internet

We will also establish a strong internet presence in order to attract customers using online catalogues. We will accomplish this by taking steps to ensure that our website and walker is high on the results list for searches for geriatric walkers and mobility aid devices and companies that sell those products. We will also design our website to show up high in searches for products similar to ours and in searches for the company name or parts of it. Additionally, we will partner with websites and directories that are related to the walker and geriatric mobility industry to have them post links to our website on their web pages. We expect our internet advertising campaign to cost up to \$2,000 per year plus \$5 thousand to \$10 thousand for website design.

5.4.5 Marketing Through Caregivers

Nearly all walker users buy their walkers as a result of a doctor recommendation and we recognize the powerful opportunity that exists in gaining the trust and recommendation of doctors. In order to increase our exposure and maximize our number of potential customers we will distribute brochures to local geriatric doctors and speak with them personally to express the benefits of the iXa Walker. As a result we hope to get doctors to prescribe their patients with walkers that will help them to safely get up out of a chair which will help to lead walker users to buy iXa Walkers.

5.4.6 Radio and Television Advertising

A radio ad campaign in Boston would cost about \$500 per ad. Additionally, television ad campaigns in the Boston area would cost several thousand dollars to produce and put on the air. In order to maintain low overhead we will not use radio or television advertising in the first five years. This is common practice in the industry.

5.5 Sales and Distribution

The iXa Walker Company will partner with a large manufacturer for the purpose of manufacturing and distributing iXa products. iXa Walker will then make sales to consumers through both a company run website and third party retailers.

Sales through the company website will be shipped directly to consumers using a contracted shipping company. Shipping individual walkers will cost between \$10 and \$20 per walker depending on where in the US the walkers are shipped and will take up to 5 days to get from distributor to user.

Sales through third party retailers will be shipped to the retailers using traditional wholesale product delivery methods and will be made only in select markets. Third party sales will begin in the Boston area. As the company grows and our ability to ship increases we will expand retail sales to other cities in the New England region. However, we do not intend to expand retail sales within the first five years of operation. This will give us time to build up a national customer base through the internet and install the infrastructure needed to be able to ship to our intended markets. Shipping to retailers is expected to cost up to \$15 per walker and take up to 5 days for delivery.

Sales and Distribution Channels

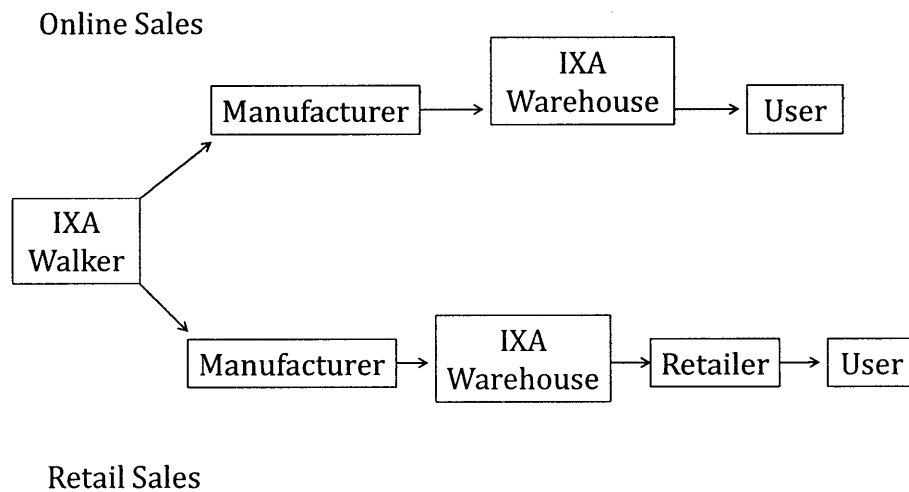

Figure 21. Sales and distribution channels

At 14% market penetration a retailer selling 500 walkers per year will sell about 73 iXa walkers in a year, or about 6 per month. Since this is a small number of walkers per month,

we expect that retailers will keep about a 2 month supply of walkers in stock along with a display walker. We will maintain normal contact with our retailers to ensure that they are properly stocked. We will also keep a small inventory of walkers in our own warehouse in case a local retailer sells out of walkers. If a retailer communicates that they would like to stock more walkers off cycle then we will deliver some of our inventory to the retailer.

6. Financial Plan

Our financial plan reflects the business decisions we will be making, as described in previous section.

6.1 Income Statement

Income Statement	Year 1	Year 2	Year 3	Year 4	Year 5
Revenue					
Gross revenue	\$24,000	\$36,000	\$110,400	\$149,040	\$193,752
Cost of goods sold	16,800	25,200	52,780	71,253	92,629
Gross margin	\$7,200	\$10,800	\$57,620	\$77,787	\$101,123
Other revenue [source]	\$0	\$0	\$0	\$0	\$0
Interest income	\$0	\$0	\$0	\$0	\$0
Total revenue	\$7,200	\$10,800	\$57,620	\$77,787	\$101,123
Operating expenses					
Sales and marketing	\$2,000	\$2,000	\$4,000	\$4,000	\$4,000
Payroll and payroll taxes	0	0	0	0	0
Depreciation	0	0	0	0	0
Insurance	5,000	5,000	5,000	5,000	5,000
Maintenance, repair, and overhaul	0	0	0	0	0
Utilities	0	0	0	0	0
Property taxes	3,000	3,000	3,000	3,000	3,000
Administrative fees	1,000	1,000	1,000	1,000	1,000
Other	10,000		10,000		
Total operating expenses	\$21,000	\$11,000	\$23,000	\$13,000	\$13,000
Operating income	(\$13,800)	(\$200)	\$34,620	\$64,787	\$88,123
Interest expense on long-term debt	763	609	447	278	100
Operating income before other items	(\$14,563)	(\$809)	\$34,173	\$64,509	\$88,023
Loss (gain) on sale of assets	0	0	0	0	0
Other unusual expenses (income)	0		0	0	0
Earnings before taxes	(\$14,563)	(\$809)	\$34,173	\$64,509	\$88,023
Taxes on income	15%	0	0	5,126	9,676
Net income (loss)	(\$14,563)	(\$809)	\$29,047	\$54,833	\$74,820

6.2 Balance Sheet

Assets	Initial	Year 1	Year 2	Year 3	Year 4	Year 5
Cash/ short term investments	\$36,300	\$18,661	\$14,621	\$38,876	\$90,147	\$161,228
Accounts receivable	0	0	0	0	0	0
Total inventory	700	700	700	2,100	2,100	2,100
Prepaid expenses	0	0	0	0	0	0
Deferred income tax	0	0	0	0	0	0
Other current assets	0	0	0	0	0	0
Total current assets	\$37,000	\$19,361	\$15,321	\$40,976	\$92,247	\$163,328
Buildings	\$0	\$0	\$0	\$0	\$0	\$0
Land	0	0	0	0	0	0
Capital improvements	0	0	0	0	0	0
Machinery and equipment	0	0	0	0	0	0
Less: Accumulated depreciation	0	0	0	0	0	0
Net property/equipment	\$0	\$0	\$0	\$0	\$0	\$0
Goodwill	\$0	\$0	\$0	\$0	\$0	\$0
Deferred income tax	0	0	0	0	0	0
Long-term investments	0	0	0	0	0	0
Deposits	0	0	0	0	0	0
Other long-term assets	0	0	0	0	0	0
Total assets	\$37,000	\$19,361	\$15,321	\$40,976	\$92,247	\$163,328
Liabilities	Initial	Year 1	Year 2	Year 3	Year 4	Year 5
Accounts payable	\$0	\$0	\$0	\$0	\$0	\$0
Accrued expenses	0	0	0	0	0	0
Notes payable/short-term debt	0	0	0	0	0	0
Capital leases	0	0	0	0	0	0
Other current liabilities	0	0	0	0	0	0
Total current liabilities	\$0	\$0	\$0	\$0	\$0	\$0
Long-term debt	\$17,000	\$13,923	\$10,693	\$7,301	\$3,740	\$0
Other long-term debt						
Total debt	\$17,000	\$13,923	\$10,693	\$7,301	\$3,740	\$0
Other liabilities	0	0	0	0	0	0
Total liabilities	\$17,000	\$13,923	\$10,693	\$7,301	\$3,740	\$0
Equity	Initial	Year 1	Year 2	Year 3	Year 4	Year 5
Owner's equity (common)	\$20,000	\$20,000	\$20,000	\$20,000	\$20,000	\$20,000
Paid-in capital	0	0	0	0	0	0
Preferred equity	0	0	0	0	0	0
Retained earnings	0	(14,563)	(15,372)	13,675	68,508	143,328
Total equity	\$20,000	\$5,437	\$4,628	\$33,675	\$88,508	\$163,328
Total liabilities and equity	\$37,000	\$19,361	\$15,321	\$40,976	\$92,247	\$163,328

6.3 Cash Flow

	Year 1	Year 2	Year 3	Year 4	Year 5	Total
Operating activities						
Net income	(\$14,563)	(\$809)	\$29,047	\$54,833	\$74,820	\$143,328
Depreciation	0	0	0	0	0	0
Accounts receivable	0	0	0	0	0	0
Inventories	0	0	(1,400)	0	0	(1,400)
Accounts payable	0	0	0	0	0	0
Amortization	0	0	0	0	0	0
Other liabilities	0	0	0	0	0	0
Other operating cash flow items	0	0	0	0	0	0
Total operating activities	(\$14,563)	(\$809)	\$27,647	\$54,833	\$74,820	\$141,928
Investing activities						
Capital expenditures	\$0	\$0	\$0	\$0	\$0	\$0
Acquisition of business	0	0	0	0	0	0
Sale of fixed assets	\$0	\$0	\$0	\$0	\$0	0
Other investing cash flow items	0	0	0	0	0	0
Total investing activities	\$0	\$0	\$0	\$0	\$0	\$0
Financing activities						
Long-term debt/financing	(\$3,077)	(\$3,230)	(\$3,392)	(\$3,562)	(\$3,740)	(\$17,000)
Preferred stock	0	0	0	0	0	0
Total cash dividends paid	0	0	0	0	0	0
Common stock	0	0	0	0	0	0
Other financing cash flow items	0	0	0	0	0	0
Total financing activities	(\$3,077)	(\$3,230)	(\$3,392)	(\$3,562)	(\$3,740)	(\$17,000)
Cumulative cash flow	(\$17,639)	(\$4,039)	\$24,255	\$51,271	\$71,080	\$124,928
Beginning cash balance	\$36,300	\$18,661	\$14,621	\$38,876	\$90,147	
Ending cash balance	\$18,661	\$14,621	\$38,876	\$90,147	\$161,228	

7. Conclusion

We believe that iXa Walker is an innovative product with many promises to the elderly. We believe that with help of an established manufacturer, we will be able to navigate the landscape of the durable medical equipment industry. We hope that this business plan has established the fact that this is a profitable venture and that you would consider investing your resources to iXa Walker.

8. Acknowledgement

We would like to thank our advisor, Maria Yang, whose guidance this semester has helped us tremendously. We would also like to thank the 2.009 purple team members for their help and support developing this business plan.

Lastly, we thank Somerville Homes, Champa Apothecary, Cambridge Medical Supply, and Belmont Medical Supply Company for their help in the research and development of the iXa walker.