

University of Warwick institutional repository: <http://go.warwick.ac.uk/wrap>

A Thesis Submitted for the Degree of PhD at the University of Warwick

<http://go.warwick.ac.uk/wrap/4453>

This thesis is made available online and is protected by original copyright.

Please scroll down to view the document itself.

Please refer to the repository record for this item for information to help you to cite it. Our policy information is available from the repository home page.

IMPROVED PROCESSES FOR THE PRODUCTION OF SOIL-CEMENT BUILDING BLOCKS

**AUTHOR : DOMINIC EDWARD MAXWELL
GOODING**

**SUBMITTED FOR
THE DEGREE OF : DOCTOR OF PHILOSOPHY
IN THE FACULTY OF ENGINEERING**

SUBMITTED TO : THE UNIVERSITY OF WARWICK

**RESEARCH
CONDUCTED AT : DEPARTMENT OF ENGINEERING
THE UNIVERSITY OF WARWICK**

DATE SUBMITTED : NOVEMBER 1994

SUMMARY

Stabilised-soil cement building blocks are an established building material in many areas of the Less Developed World. This thesis has been split into three parts. Part A presented an overview of the process of soil-stabilisation and outlined the roles which soil structure and curing play in stabilisation. It examined methods of testing soils, highlighting errors presented in the published literature and presenting corrected testing procedures and unified plans for their implementation.

Part B examined the conventional quasi-static block compaction process (slowly applied pressure) and established that no cost-effective increase in the compacted block density can be achieved by altering such moulding configurations as mould-wall roughness, mould-wall taper, number of applied pressure cycles and double-sided pressure application. The tests were also used to assess the plausibility of several theoretical mechanisms underlying quasi-static compaction.

Cement may be traded against compaction pressure for a given final cured strength. The relation of compaction pressure and cement content to well-cured strength was established for 50 mm diameter cylinders and used to assess the financial benefit of high-pressure compaction. It was shown that savings in the cost of cement associated with high-pressure compaction were outweighed by the additional cost of such machinery. However there were additional benefits found to high-density compaction, beyond the saving in stabiliser costs. It was established that a high-density moulding machine in the range £1000 - £1500 would allow these benefits to become cost competitive.

Part C examined both experimentally and theoretically an alternative dynamic (impact blow) compaction process, establishing that optimised dynamic compaction may produce strength equivalent to quasi-static high-density moulding while requiring only 25-50 % of the energy. Five theoretical models of the process were developed and the Combined Airlock/Friction/Compression Wave Model was shown to have the most explanatory power.

CONTENTS

1	INTRODUCTION	page
1.1	SOIL AS A BUILDING MATERIAL	15
1.2	LITERATURE REVIEW	18
1.2.1	<i>SOIL STABILISATION METHODS AND MECHANISMS</i> .	18
1.2.2	<i>SOIL AND STABILISER SELECTION AND TESTING</i> ...	19
1.2.3	<i>LITERATURE DESCRIBING THE STANDARD QUASI-STATIC MOULDING PROCESS</i>	21
1.2.4	<i>THE DYNAMIC MOULDING PROCESS</i>	27
1.3	THE STRUCTURE OF THIS THESIS	35
1.3.1	<i>OUTLINE OF PART A</i>	35
1.3.2	<i>OUTLINE OF PART B</i>	36
1.3.3	<i>OUTLINE OF PART C</i>	37
 PART A SOIL STABILISATION		
2	SOIL STABILISATION METHODS AND MECHANISMS	
2.1	UNSTABILISED-SOIL WALLING	40
2.1.1	<i>INTRODUCTION</i>	40
2.1.2	<i>THE EFFECT OF WATER ON UNSTABILISED SOIL</i> ...	41
2.1.3	<i>SOIL PROPERTIES AFFECTING STRENGTH</i>	43
2.2	STABILISED-SOIL WALLING	45
2.2.1	<i>INTRODUCTION</i>	45
2.2.2	<i>IMPROVED BUILDING DESIGN (ARCHITECTURE)</i> ...	45
2.2.3	<i>INCREASED DENSITY</i>	46
2.2.4	<i>WATERPROOFING</i>	47
2.2.5	<i>CEMENTITIOUS BINDERS</i>	49
2.2.6	<i>SUMMARY OF STABILISATION METHODS</i>	51
2.2.7	<i>CEMENT-STABILISED SOIL WALLING</i>	52
2.3	PRODUCTION AND CURING OF STABILISED SOIL-CEMENT BUILDING BLOCKS	54
2.3.1	<i>INTRODUCTION</i>	54
2.3.2	<i>OPTIMUM MOISTURE CONTENT</i>	54
2.3.3	<i>SOIL MIXING, BATCHING AND MOULD FILLING</i> ...	58
2.3.4	<i>SOIL COMPACTION, BLOCK EJECTION AND CURING</i>	61

3 SOIL TESTING FOR SOIL-CEMENT PRODUCTION

3.1	PROPERTIES OF SOIL FOR SOIL-CEMENT	64
3.1.1	GENERAL PROPERTIES	64
3.1.2	PARTICLE GRADING	65
3.1.3	PLASTICITY (FINES CONTENT)	67
3.2	SUITABLE SOILS	69
3.2.1	OVERVIEW	69
3.2.2	SURVEY OF AVAILABLE CRITERIA FOR SOIL SUITABILITY	69
3.2.3	THE SOIL USED FOR EXPERIMENTAL INVESTIGATIONS CONTAINED IN THIS THESIS	75
3.3	TESTS FOR SOILS	75
3.3.1	TYPES OF TEST	75
3.3.2	FIELD TESTS	76
3.3.3	LABORATORY TESTS	79
3.4	COHERENT SOIL TESTING PLANS	93
3.4.1	INTRODUCTION	93
3.4.2	PRELIMINARY ON-SITE SOIL TESTING PLAN	97
3.4.3	FIELD TESTING TREE TO ILLUSTRATE A COHERENT SOIL-TESTING PLAN	100
3.4.4	LABORATORY TESTING PLANS	101

PART B SLOW COMPACTION

4 QUASI-STATIC COMPACTION OF SOIL-CEMENT BLOCKS

4.1	INTRODUCTION TO QUASI-STATIC COMPACTION	104
4.2	MODELS TO DESCRIBE THE INTERNAL COMPACTION MECHANISM FOR COMPRESSED BLOCKS PRODUCED BY QUASI-STATIC COMPRESSION	106
4.2.1	SIMPLE HYDROSTATIC FLUID MODEL	107
4.2.2	PIPE FLOW MODEL	107
4.2.3	SOLID MODEL (POISSON'S RATIO)	109
4.2.4	FRictional POISSON FLOW	111
4.2.5	EFFECTIVE-PRESSURE MODEL	112
4.3	INTRODUCTION TO QUASI-STATIC EXPERIMENTATION ..	114
4.4	SINGLE-SIDED COMPACTION - THE DATUM PROCESS	116
4.4.1	ANALYSIS OF THE SINGLE-SIDED COMPACTION PROCESS	120
4.5	DOUBLE-SIDED COMPACTION	123

4.6	REDUCTION IN MOULD-WALL FRICTION	126
4.7	MOULD-WALL TAPER	127
4.8	PRESSURE CYCLING	129
4.8.1	<i>FULL PRESSURE CYCLING</i>	130
4.8.2	<i>PARTIAL PRESSURE CYCLING</i>	132
4.8.3	<i>ANALYSIS OF APPLIED PRESSURE CYCLING</i>	133
4.9	THE EFFECTS OF QUASI-STATIC SINGLE AND DOUBLE-SIDED COMPACTION ON CEMENT-STABILISED SOIL BLOCKS.	137
4.9.1	<i>INTRODUCTION</i>	137
4.9.2	<i>THE COMPRESSIVE STRENGTH OF CEMENT-STABILISED BLOCKS COMPACTED BY SINGLE AND DOUBLE-SIDED COMPACTION METHODS</i>	138
4.9.3	<i>A COMPARISON OF THE INTERNAL DISTRIBUTION OF STRENGTH RESULTING FROM SINGLE AND DOUBLE-SIDED COMPACTION</i>	139
5	THE RELATION OF STRENGTH AND DURABILITY TO CEMENT CONTENT AND MOULDING PRESSURE	
5.1	INTRODUCTION	146
5.2	EXPERIMENTAL INVESTIGATION OF THE RELATION OF STRENGTH TO CEMENT CONTENT AND MOULDING PRESSURE	149
5.3	THE EFFECT OF COMPACTION PRESSURE AND ENERGY ON SEVEN-DAY WET COMPRESSIVE STRENGTH	151
5.4	THE EFFECT OF CEMENT CONTENT ON SEVEN-DAY WET COMPRESSIVE STRENGTH	153
5.5	THE PRESSURE-CEMENT-STRENGTH RELATIONSHIP	154
5.6	A SIMPLE ECONOMIC COMPARISON BETWEEN MACHINES GIVING RESPECTIVELY 2 AND 10 MPa COMPACTION	157
5.7	THE EFFECT OF COMPACTION PRESSURE ON GREEN BLOCK STRENGTH	168
5.8	THE RELATION OF BLOCK DURABILITY TO COMPACTION PRESSURE AND CEMENT CONTENT	169
5.9	THE EFFECT OF POOR CURING ON STRENGTH AND DURABILITY RELATED TO COMPACTION PRESSURE AND CEMENT CONTENT	175
5.9.1	<i>INTRODUCTION</i>	175
5.9.2	<i>EXPERIMENTAL INVESTIGATION OF THE EFFECT OF SIMULATED SOLAR CURING ON BLOCK COMPRESSIVE STRENGTH AND SURFACE SCRATCH RESISTANCE</i>	177
5.9.3	<i>DISCUSSION OF EXPERIMENTAL RESULTS</i>	179

5.10	RECOMMENDATIONS FOR BLOCK CURING	185
5.11	CONCLUSIONS CONCERNING CHAPTER FIVE	187

PART C DYNAMIC COMPACTION

6 INTRODUCTION TO DYNAMIC COMPACTION

6.1	INTRODUCTION	191
6.2	MACHINE IMPLICATIONS OF DYNAMIC COMPACTION ...	192
6.3	THE POTENTIAL BENEFITS OF DYNAMIC COMPACTION FOR BLOCK PROPERTIES	189
6.4	THE APPLICATION OF AN IMPACT BLOW	194
6.5	MODELS TO DESCRIBE THE PROCESS OF COMPACTION BY IMPACT	196
6.5.1	<i>FAST QUASI-STATIC MODEL</i>	196
6.5.2	<i>AIRLOCK MODEL</i>	197
6.5.3	<i>SOFT HYSTERIC SPRING</i>	198
6.5.4	<i>COMPRESSION WAVE MODEL</i>	199
6.6	INTRODUCTION TO THE EXPERIMENTAL INVESTIGATION OF DYNAMIC COMPACTION	201
6.7	EXPERIMENTAL DESIGN	202
6.7.1	<i>CALCULATION OF THE ENERGY APPLIED BY THE IMPACT RIG</i>	203

7 ANALYSIS OF EXPERIMENTAL INVESTIGATION OF DYNAMIC COMPACTION

7.1	IMPACT COMPACTION EFFICIENCY	206
7.2	THE COMPRESSIVE STRENGTH OF IMPACT AND QUASI- STATIC CYLINDERS	210
7.3	OPTIMISATION OF IMPACT COMPACTION	212
7.3.1	<i>TOTAL APPLIED ENERGY</i>	213
7.3.2	<i>NUMBER OF BLOWS</i>	214
7.3.3	<i>IMPACTOR MOMENTUM</i>	216
7.3.4	<i>IMPACTOR ENERGY</i>	218
7.4	ANALYSIS OF DYNAMIC COMPACTION MODELS	220
7.4.1	<i>FAST QUASI-STATIC MODEL</i>	220
7.4.2	<i>AIRLOCK MODEL</i>	221
7.4.3	<i>SOFT HYSTERIC SPRING</i>	222
7.4.4	<i>COMPRESSION WAVE MODEL</i>	223
7.4.5	<i>COMBINED MODEL</i>	223
7.5	IMPLICATIONS FOR MACHINE DESIGNS FOR STANDARD-SIZE BLOCK COMPACTION	226
7.6	CONCLUSIONS CONCERNING CHAPTER SEVEN	228

8 COMPUTER SIMULATION OF CONFINED DYNAMIC SOIL COMPACTION

8.1	INTRODUCTION	231
8.2	SIMULATION LOGIC	232
8.3	RESULTS OF SIMULATION	236

CONCLUSIONS

9 CONCLUSIONS AND AREAS FOR FURTHER WORK

9.1	CONCLUSIONS CONCERNING SOIL STABILISATION	241
9.2	QUASI-STATIC COMPACTION	243
9.3	DYNAMIC COMPACTION	250
9.4	AREAS FOR FURTHER WORK	255

BIBLIOGRAPHY	258
---------------------------	------------

APPENDICES

APPENDIX A: DESCRIPTION OF <i>SOIL-A</i>	263
APPENDIX B: RECOMMENDED SOIL-TESTING PROCEDURES FOR FIELD USE	265
APPENDIX C: RECOMMENDED SOIL-TESTING PROCEDURES FOR LABORATORY USE	277
APPENDIX D: EXPERIMENTAL METHOD USED TO PRODUCE STANDARD-SIZE BLOCKS AND SMALL CYLINDERS (50mm diameter) BY QUASI-STATIC COMPACTION	287
APPENDIX E: EXPERIMENTAL EQUIPMENT AND INSTRUMENTATION USED DURING QUASI-STATIC COMPACTION OF STANDARD-SIZE BLOCKS	292
APPENDIX F: EXPERIMENTAL READINGS FOUND DURING QUASI-STATIC COMPACTION OF STANDARD-SIZE BLOCKS	300
APPENDIX G: COMPRESSIVE STRENGTH VALUES OBTAINED BY SECTIONING STANDARD-SIZE BLOCKS STABILISED WITH 5% CEMENT	316
APPENDIX H: EXPERIMENTAL DATA USED TO CONSTRUCT THE PRESSURE-CEMENT-STRENGTH RELATION	319

APPENDIX I: DESCRIPTION OF THE SCRATCH TESTING APPARATUS	323
APPENDIX J: EXPERIMENTAL READINGS CONCERNING THE SCRATCH TEST	325
APPENDIX K: DESCRIPTION OF THE EXPERIMENTAL RIG USED FOR IMPACT COMPACTION	328
APPENDIX L: EXPERIMENTAL METHOD USED DURING IMPACT COMPACTION	338
APPENDIX M: NUMERICAL RESULTS FOUND DURING IMPACT COMPACTION	340
APPENDIX N: UNCOMPILED FORTRAN LISTING OF FINAL SIMULATION PROGRAM	343

LIST OF TABLES

3.3.2	Field tests reported by other authors	78
4.4	Average transmitted pressure recorded by LVDT's	119
4.8a	Pressure transmission on full-pressure cycling	130
4.8b	Pressure values relating to figure 4.8c	133
4.9.2	The compressive strength and bulk ejection density resulting from single and double-sided compaction methods.	138
4.9.3a	Pattern of strength distribution for standard single-sided compaction	142
4.9.3b	Pattern of strength distribution for double-sided compaction	144
5.5	The relative effects of pressure, energy and cement on compressive strength	156
5.6a	Block production cost comparison (Sri Lanka)	163
5.6b	Percentage breakdown of block costs (Sri Lanka)	164
5.6c	Block production cost comparison (rural Zimbabwe)	165
5.6d	Percentage breakdown of block costs (Zimbabwe)	165
5.6e	Block production cost comparison (if £6.00 per 50 kg of cement in Sri Lanka)	166
5.6f	Capital cost required of a high pressure compaction machine for economic parity with low pressure compaction	168
5.9a	The effect of solar curing on block-side surface strength	179
5.9b	The effect of solar curing on surface strength for top and base block faces	182
5.9c	Wet compressive strength comparison between blocks manufactured by high and low pressure compaction subjected to standard and solar curing	183

6.7	Impact combinations used to generate a total impact energy of 464J . .	205
7.2	Comparison of compressive strength for a constant bulk density produced by quasi-static and impact compaction	210

LIST OF ILLUSTRATIONS

2.1.2	Water layers surrounding a clay particle	41
2.3.2a	Dry density plotted against water content	55
2.3.2b	Flocculated structure	57
2.3.2c	Dispersed structure	58
2.3.3	Cured strength loss due to compaction delay after West in Ingles & Metcalf (1972)	60
3.2.2a	Interpretation of Atterburg Limits	70
3.2.2b	Particle size criteria granulation curve	72
3.2.2c	Triangular chart for particle size classification of soils	73
3.2.2d	Plasticity chart showing soils most suitable for stabilisation	74
3.4.3	Field testing tree to illustrate a coherent soil-testing plan	100
4.2.2	The rate of change of top layer velocity and displacement with time for pipe-flow behaviour	109
4.2.5	Schematic representation relating to the effective-pressure model, showing the migration of the saturated zone during compaction	113
4.4a	The effect of applied top compaction pressure on pressure transmitted to the mould by the compacting soil	117
4.4b	The location of the LVDT transducers in the mould wall	118
4.4c	The effect of top pressure on block height during initial compaction and 4 subsequent full pressure cycles	120
4.5	The effect of double-sided pressure application on the pressure transmitted to the mould	124
4.6	The effect of smooth walls on applied top pressure transmission	126

4.7	The effect of 1° mould wall taper on applied top pressure transmission	128
4.8a	Pressure recorded on the mould wall (upper, central and lower) at the peaks of 5 successive full-pressure cycles	130
4.8b	The effect of top pressure on block height during compaction for 5 successive full-pressure cycles	131
4.8c	The effect of partial pressure cycling on applied top pressure transmission to the mould walls	132
4.9.3	Schematic representation of the identification sequence used when sectioning the blocks	140
5.3a	The effect of increasing compaction pressure on seven-day wet compressive strength	151
5.3b	The effect of compaction energy on seven-day wet compressive strength	152
5.4	The effect of cement content on seven-day wet compressive strength . .	153
5.5a	A contour plot relating compressive strength to cement content and compaction pressure	154
5.5b	The relation of compacted bulk density to seven-day compressive strength, when the cement content is kept constant	157
5.8a	The correlation of durability with the inferred compressive strength . .	171
5.8b	The correlation of durability with dry density	172
5.8c	The correlation of durability with compaction pressure	173
5.8d	The correlation of durability with cement content	174
5.9	The effect of compaction pressure on water loss when subjected to simulated solar curing	178
6.7	Energy used by the quasi-static compaction of a standard-size block to 9.7 MPa	203

7.1a	The effect of the number of impact blows on bulk density	207
7.1b	The density-energy-pressure relations for a quasi-statically compacted (standard-size) block	208
7.1c	The density-energy-pressure relations for a sample compacted quasi- statically in the impact cylinder mould	209
7.3.1	Density gain during discrete impact compaction	213
7.3.3a	The effect of momentum per blow on compacted bulk density	216
7.3.3b	The effect of cumulative momentum on bulk density	217
7.3.3c	The effect of impact velocity on bulk density	218
7.3.4a	The effect of energy per blow per kg on bulk density	219
7.3.4b	The effect of Joules per blow on bulk density at different levels of total energy	219
8.2a	Schematic diagram indicating the spring/mass orientation used during the simulation	233
8.2b	Schematic representation of the spring constants used to simulate hysteresis	235
8.3a	Absolute layer displacement against time for a single blow from the 64 blow sequence of the 23.35kg impactor mass	237
8.3b	Absolute layer displacement against time for a single blow from the 1 blow sequence of the 23.35 kg impactor mass	238
E1	LVDT transducer assembly drawing	294
E2	LVDT transducer spring body	295
E3	LVDT transducer parts	296
E4	Calibration of the LVDT transducer No.1	297
E5	Calibration of the LVDT transducer No.2	297
E6	Transducer location sites in mould-side wall	298

G	Schematic diagram to illustrate the number sequence used to identify the block sections tested for compressive strength	318
I	Schematic illustration of scratch testing apparatus	324
K1	Assembly drawing of the impact rig showing the pneumatic ram, guide tube, mounting points and base plate	333
K2	Detail showing dimensions of the impact base on which the mould is located	334
K3	Detail showing dimensions of lower mount collar which couples the lower guide pipe with the impact mould	334
K4	Detail showing dimensions of top access mounting plate	335
K5	Detail showing dimensions of top access mounting collar	335
K6	Detail showing dimensions of datum mounting plate	336
K7	Detail showing dimensions of upper ram mounting plate	336
K8	Detail showing dimensions of upper ram mounting collar	337
K9	Circuit diagram showing power supply and switch system for the electromagnet	337

ACKNOWLEDGEMENTS

The author wishes to express his gratitude to Dr T H Thomas and Dr C E Oram of the University of Warwick for their supervision of this thesis and their valuable time spent discussing aspects of this research.

The author also wishes to thank Dr D J Petley and Dr D Anderson for the use of their laboratory and office space.

Sincere thanks also to Mr C Banks, Mr D Smith and Mr G Hackett for their assistance with the construction and operation of the experimental apparatus used.

DECLARATION

This thesis is the exclusive work of the author except for the numerical results presented in section 5.8, The relation of block durability to compaction pressure and cement content (pages 166 - 169). These results were obtained by Sutcliffe (1994), a third-year undergraduate engineering student at the University of Warwick, who was advised by the author.

1 INTRODUCTION

1.1 SOIL AS A BUILDING MATERIAL

Soil is one of the oldest building materials in the world. It is usually readily won and processed with only simple hand tools. The processed soil may be easily moulded or compressed to form a building material which possesses good compressive strength, while it remains dry. As some form of soil covers virtually the whole land surface of the earth it is not surprising that soil has been traditionally used for construction in all but the wettest climates, indeed it is probably still true that there are "more buildings in the world whose walls are built with soil than with any other material" Spence and Cook (1983). The large scale use of soil in the past and its continued widespread availability as a raw material suggests that it will continue to be a significant building material for the foreseeable future.

There are essentially four types of traditional unstabilised soil walling which are known as; wattle and daub, cobb, sun-dried mud brick and rammed earth. In more recent times these materials have become stigmatised as being second rate and inferior to the more modern concrete and fired brick. The huge variation in soil types which exist within one country, let alone the world, has led to great difficulty in predicting the properties of soil-based building materials. The more modern materials are by contrast more predictable and hence are preferred by engineers and architects. Moreover traditional unstabilised-soil building methods result in structures which frequently have a short life or a high maintenance cost as a result of their low strength

and poor dimensional stability. This experience with *unstabilised* soil structures has led to the association of soil with substandard or temporary buildings in the minds of many. This thesis is concerned with *stabilised* earth walling and stabilised soil building blocks in particular. Some mention will be made of the densification techniques common to rammed earth walling but other than this the traditional techniques for unstabilised construction are not covered. The bulk of the thesis focuses specifically on soil-cement.

The prime drawback to building with earth is that its compressive strength is lost when it becomes wet; even highly compressed rammed earth will revert to mud if it is subjected to prolonged water saturation. The aim of the various soil stabilisation processes is two fold, to increase the wet strength of the wall such that even after prolonged saturation the wall will not collapse and to increase the wall's durability thereby reducing the maintenance cost and extending the building's life. With successful stabilisation, soil may be fully comparable with other types of walling material.

Historically in many countries any buildings which were considered to be of importance were built of brick or stone, both of these materials being substantially more durable and requiring much lower maintenance than soil. However with the emergence of Soil Mechanics (the scientific study of soil) in the 1930's it became possible to specify and select soils for building in terms of their properties. The particle grading, plasticity and organic or soluble salt level could be used to help predict the suitability of soils for certain construction uses.

The modern methods of soil stabilisation were first developed forty years ago for the construction of roads and runways. Fitzmaurice (1958) noted that "There is now a large fund of scientific knowledge of soils and methods of stabilising them, but with a strong bias towards the special requirements of the highway and airfield engineer....the problem at the present time is to translate some of the large fund of

knowledge in earth engineering to the needs of the builder in earth walling". Twenty five years later Spence and Cook (1983) seemed to echo Fitzmaurice, saying "There is a shortage of recent good works on soil and stabilised soil construction technology; some of the best reviews were published some years ago." Another ten years on Fitzmaurice's (1958) observation that "On the scientific plane, (earth) building has been somewhat neglected" is still true. Moreover the "large fund of scientific knowledge" to which he refers is becoming progressively harder to access as the various works are now long since out of print.

It is these early studies which form the basis for much of the construction done in the field. Indeed in many cases the more recent publications are somewhat misleading, reproducing earlier work out of context and misquoting to the extent that the original meaning of the work is lost.

Much of the practical work on soil stabilisation which has been reported in the literature is poorly documented both in terms of the characteristics of the soil used as the basis for stabilisation and the method used to compact the sample. For example Lunt (1980), writing for the Building Research Establishment, describes the effect of lime stabilisation on two Ghanaian soils namely "Kumasi soil" and "Fumesua soil". Although a particle size grading is given for both soils it is of very limited use as it groups the silt and clay fractions of the soil together as a single fines content. In the case of the Kumasi soil this fines content is quoted as 56% and that for the Fumesua 49%. The clay and silt soil fractions have dramatically differing effects on chemical stabilisation and compaction as a result of their differing specific surface areas; typically $0.23\text{m}^2/\text{g}$ for silt and $1000\text{m}^2/\text{g}$ for montmorillonite clay (Head 1980). Moreover neither the liquid limit nor the plastic limit are given. Although this poor definition of the soil properties does not invalidate the results reported it does lead to great difficulty in relating this work to that of others engaged in similar research.

As a result of this rather loose reporting, the literature review conducted at the outset of this research raised rather more questions than were answered. The following sections will describe the state of knowledge which has become apparent from the literature available to the author and outline the work which has been conducted to extend and unify this knowledge.

1.2 LITERATURE REVIEW

1.2.1 SOIL STABILISATION METHODS AND MECHANISMS

In general the published literature may be divided into two categories, one biased towards an academic overview and one towards the field practitioner. Very little laboratory-type academic research has been conducted.

The field practitioner texts describe how to stabilise a soil in various ways without conveying the basis for understanding why the various methods work. The stabilisation methods are frequently described in practical detail, even to the level of when and how to add water to the soil mix. However they appear to have been written as the result of practical field projects rather than the result of scientific study. They tend to make definitive statements on methodology which are unfortunately not universally applicable to all soil types, possible locations or machinery. The detailed level of instruction suggests to the inexperienced reader that the indicated method is the only acceptable one. Although practical detail is useful to the field worker, it is impossible to describe the most appropriate method for every situation. Instead it would appear far better to include sufficient theoretical background, presented in simple terms, to enable the individual project to determine which methodology is most useful. The general trend is to oversimplify or omit explanation of the mechanisms thought to be responsible. The more modern publications are particularly susceptible to this criticism.

Conversely the academically orientated texts provide explanations of the mechanisms involved but without the practical detail to enable actual production. There is no adequate text on soil stabilisation which contains both the practical and the theoretical information necessary to promote understanding and hence enable maximum production efficiency. Although the field-worker texts do contain references to the academic texts it is unlikely that their readers would be able to gain access to such material particularly as the references are frequently 30-40 years old.

In summary, soil stabilisation methods are broadly understood although when examined closely the practical details are frequently misleading. Soil stabilisation is highly susceptible to faults resulting from poor understanding and consequent poor quality control, a comprehensive publication which includes both the practical and the theoretical information required to develop understanding is lacking.

1.2.2 SOIL AND STABILISER SELECTION AND TESTING

The selection of a suitable soil or the modification of an unsuitable soil is one of the most important stages in the production of stabilised soil-cement blocks. As soil constitutes at least 90% of the final block it should not be surprising that the type of soil has a profound effect both on the type and amount of stabiliser required and on the final properties exhibited by the block.

There are a number of recommended specifications for soil suitable for soil-cement block production (Fitzmaurice (1958), United Nations (1964), Doat et al (1972), Spence & Cook (1983), Stulz (1983), ILO (1987)) however these range widely, reflecting the different types of soil, compaction machinery and final cured strength required of the block. Again the theoretical background to enable an understanding of why some soils are suitable and some are unsuitable is generally absent from the field worker-type literature.

The soil testing procedures which are recommended by the literature may be divided into two groups; field tests and laboratory tests. The laboratory tests are generally recommended for "large" projects. These tests are either the British or American standard tests (B.S. or A.S.T.M). Both sets of test are well proven and accurate, however they require specialised equipment which is frequently not available in developing countries.

The field tests are simplified versions of the standard tests, requiring less complicated equipment which should be more readily available. These field tests are neither well proven nor adequately reported. The methodology described in the literature is frequently inadequate and in some cases incorrect.

At the outset of this research the author attempted to use a number of the field tests to classify several soils and as a consequence of the poor results conducted a systematic review of the tests in the available literature. The results of this review are presented in chapter three, while a recommended field testing procedure is included in Appendix B. Subsequent to this investigation, Dr Peter Walker of the University of Zimbabwe conducted a similar set of trials for the field tests reported in Norton (1986) and also concluded that the methods reported are inadequate.

A fundamental discussion which is frequently absent from the soil selection and testing literature is whether an existing and available soil should dictate the type of stabilisation process used or whether the type of stabilisation should infer the type of soil to be found. This issue is discussed briefly in chapter three although it is essentially beyond the scope of this thesis.

The criteria for selecting suitable soil varies significantly from publication to publication and usually lacks a discussion of how the various soil properties interact with the stabiliser and the effect of compaction pressure on soil selection. The concept of soil modification (improving soil properties by blending different soils) is very poorly covered from a practical viewpoint: soil modification is frequently

mentioned but no guidelines are given. Although the decision to modify the soil must be made on the information relevant to each individual site certain simple guidelines would be useful to the practitioner.

1.2.3 LITERATURE DESCRIBING THE STANDARD QUASI-STATIC MOULDING PROCESS

Introduction

The general trend in stabilised soil block production has been to use slowly applied pressure (quasi-static compaction) rather than either impact or vibration (dynamic compaction) to compact the soil-cement mixture. This course seems to have been followed without any detailed investigation into the benefits and drawbacks associated with this form of compaction. Rather it appears that pressure has been used as a result of early work done with the Cinva Ram, a very simple and robust pressure compaction device. This machine compacted the soil-cement mixture to a comparatively low pressure of typically 1.5 - 2 MPa. For pressure in this range such a manually operated lever-type press is adequate, however the blocks produced at this low pressure display poor properties (low values for wet compressive strength, fresh demould strength and durability) unless quite large quantities of cement are used. Moulding may be carried out under higher compaction pressures to enable a reduction in the amount of cement required, however above compaction pressures of 3-4 MPa a simple lever press is inadequate and a hydraulic circuit must be used. The incorporation of a hydraulic circuit renders the machines expensive (typically ten times as expensive as the Cinva Ram type) and slow (the hydraulic circuit must be pressurised in addition to pre-compaction by lever toggle). Any machine incorporating a hydraulic circuit is also more susceptible to breakdown or sabotage. In the event of the failure of a hydraulic circuit, local repair would depend on the supply of spare

parts rather than simply the availability of a competent local fabricator as would be the case for a Cinva Ram.

Process factors affecting the strength of blocks

During the course of the literature review it became rapidly apparent that little study has been made of the quasi-static compaction process in terms of such process factors as the type of moulding machinery, orientation and force application.

No references have been found which describe the effect of altering moulding parameters, with the exception of the effect of compaction pressure on the cured strength of lime-stabilised blocks (Lunt 1980). The other parameters which could affect the block compaction process in terms of the absolute densification, distribution of density through the block and the ease of block ejection are mould-wall friction, mould-wall taper, applied pressure cycling and double-sided pressure application.

Lunt (1980) has shown for lime stabilisation of two soils with a high fines content, that an increase in quasi-static compaction pressure gives rise to an increase in cured compressive strength. This may be intuitively expected, as an increase in compaction pressure will result in an increase in green block density and hence an increase in cured block strength.

Lunt used the same stabiliser content throughout his investigation of increased compaction pressure concluding that "presses operating in the range 8 to 16 MPa could give satisfactory and economical results". If it is assumed that by increasing compaction pressure the block density and hence the compressive strength will be increased, then an important corollary is that for a constant strength raising compaction pressure allows cement content to be reduced. If highly compacted blocks are to be economical then for a given strength the increased plant costs and compaction time must be offset by an equivalent or greater cost saving in the stabiliser

quantity required. No investigation of such pressure-stabiliser trade off appears to have been conducted.

Moreover Lunt reported that the long term durability of the final cured blocks would be improved by higher compaction pressures, in this case durability was judged by a water spray-erosion test. As all of the blocks were made with the same stabiliser content and hence increased in strength as the compaction pressure was raised, it would be expected that durability would increase. What has not been examined is the change in durability of blocks of *equal* compressive strength produced under different combinations of compaction pressure and stabiliser content.

The cured strength required of the blocks appears to have been one of the prime reasons for the investigation of high pressure compaction. Webb (1988) has recommended that the cured wet strength should be 2.8 MPa (the minimum strength required of conventional concrete blocks), as with such a high wet strength the wall should be adequately durable without resorting to any external renderings. For low pressure compaction significant quantities of cement are required to produce such a strength (frequently greater than 10%). A less stringent strength standard of 0.7 - 1.4 MPa has also been used by a number of authors (first quoted by Fitzmaurice, 1958). These lower strength standards provide sufficient structural strength for single storey buildings but are generally inadequate for long term durability. Low strength blocks are therefore usually rendered to increase the building's durability. However rendering a low strength block has its own associated problems, because of the low dimensional stability of such blocks renders must be maintained at frequent intervals.

Actual durability (estimation of building life) is difficult to test as no calibrated durability measure has yet been established for soil-cement. Relative durability may be judged by a variety of accelerated erosion tests such as the water spray test used by Lunt (see above). What is not clear is the advantage or disadvantage of high pressure compaction in terms of durability. It is likely that blocks of the same wet

strength but moulded at different compaction pressures (hence having different dry density, permeability and cement content) will have different durabilities. It is the author's opinion that adequate durability, rather than high compressive strength, is the key to widespread acceptance of soil-cement.

It may be argued that higher pressure compaction produces higher density blocks which are hence less permeable to water and therefore will be more durable. However it could also be argued that low pressure blocks, having a higher cement content to compensate for their lower density, will exhibit increased particle restraint and hence increased durability. Without testing it is impossible to say which factor if either will dominate durability.

No report of any investigation of the transmission of pressure through the block during the compaction process has been found. The transmission of the pressure applied to the soil during compaction is of interest to mould designers to enable the forces acting on the mould walls during compaction to be estimated and hence allow the most economic use of mould-wall material to be made. It is also of interest in evaluating the effectiveness of varying the moulding parameters.

It appears unclear on what basis the prevailing moulds have been designed. As pressure transmission has not apparently been studied, the internal state of the soil during moulding is unknown. If the soil attains a hydrostatic condition then the entire mould-box should be designed to withstand the pressure applied to the moving face. Moreover if the internal conditions were hydrostatic then it may prove possible to apply the compaction pressure to one of the smaller block faces, hence requiring a lower static load, and still gain the same degree of densification. However if the soil behaves as a very viscous fluid generating significant shear forces with the mould-wall (as seen in fluid pipe flow) then the depth from the moving mould face which applies the compaction pressure would be more significant. If this pipe flow-type wall friction were to prove significant then either true double-sided or "floating mould"

compaction should give increased densification without increasing the static load applied.

The compaction of semi-dry soil-cement shares certain similarities with the formation of both compacted sintered bearings and precast concrete elements. Both fields have been examined by the author in the course of the literature review but neither have been helpful. Several researchers have attempted to predict the internal compaction state for sintered bearings but none have been successful. Sintered bearing compaction is therefore only empirically tested.

A commercial literature search was conducted by the British Concrete Association to find any experimental or theoretical investigations concerning the compaction of semi-dry concrete used in the production of precast elements. This revealed little information, any predictive information which may exist appears to be regarded as a commercial secret and is not available in the public domain. The production of these elements is facilitated by very high pressure compaction with the purpose of expelling water from the mould through porous filter paper. The low initial water content of soil-cement mixes, typically 8-15% and the high cost of the expulsion equipment and filter paper do not make this a viable process for the production of stabilised soil-cement blocks. Moreover the literature concerned with the "optimisation" of this compaction process centres around production efficiency in terms of plant and equipment location rather than compaction methodology. Concrete compaction by impact and vibration were also examined and are discussed below under "the dynamic moulding process".

Material properties affecting the strength of blocks

Material factors (the effects of a change of soil condition on the final compacted block) have been more fully investigated. However the majority of this information has been collected in the field of soil mechanics and its interpretation into

the field of block compaction is incomplete, particularly in terms of the behaviour of freshly demoulded blocks that have been compacted at differing pressures.

The optimum moisture content for compaction is a prime example of a material factor whose effects are well documented in the soil mechanics field but somewhat lacking in the soil-cement literature. It is frequently not realised that the optimum moisture content is a variable which for a particular soil depends on the compaction pressure used and to a lesser extent on the type and quantity of stabiliser added.

The field practitioner literature frequently sites an optimum moisture content hand-test. For this test a ball of soil is dropped onto a hard surface from a height of one meter. The manner in which the soil ball behaves on hitting the floor is taken to be indicative of the moisture content relative to the ideal moisture content. This test has been reported with at least four interpretations which are significantly different and contradictory. As the optimum moisture content depends on the soil grading and on the magnitude of force used to compact the sample this is not surprising. However the lack of explanation, including mention of the compaction pressure for which the test is suitable, renders such a test inadequate and possibly highly misleading. In at least two papers (Hawkins (1988) & Perera (1993)) the drop test was used to determine the optimum moisture content for compaction. It was not clear which interpretation of the test had been used and therefore whether the moisture content used was the optimum for the situation.

Soil grading and plasticity are frequently used to define a soil's suitability for stabilisation with cement as mentioned above. What is not clear from the literature is the influence of compaction pressure on these selection criteria. In particular breakage rates as high as 50%, for freshly demoulded blocks, have been reported by Lawson (1992). The strength of freshly demoulded blocks depends on the fraction of soil which is cohesive (clay) and on the demoulded density which in turn depends on the compaction pressure used.

In summary, quasi-static compaction is sufficiently understood for a skilled practitioner to make useful blocks, if a thorough empirical testing procedure is followed. However there is little understanding of the compaction process at a scientific level. High pressure compaction has been put forward as an economical method of improving block properties but without sufficient scientific justification. It has been proved that for a given soil with a given quantity of stabiliser high pressure compaction will produce stronger, more durable blocks. It appears that high pressure compaction does have advantages if a wet strength of 2.8 MPa is required of the blocks, as low pressure compaction requires large quantities of cement to achieve such a strength. Even if high strengths are not required from the block, high pressure compaction and consequent increased density may provide increased strength for the freshly demoulded block and reduce block breakage rates.

Regardless of the compaction pressure used the internal condition of the soil mixture during compression is unknown. If the internal pressure transmission could be improved then the fundamental advantage of high pressure compaction, namely high demould density, could be achieved without increasing the pressure beyond the range which may be applied by a simple lever press machine.

1.2.4 THE DYNAMIC MOULDING PROCESS

In order to achieve the benefits of high pressure compaction without incurring the cost of a machine capable of supplying a sustained high force, alternative methods of high force application need to be examined. The most simple way to generate a high force is through impact. Although the magnitude of the force which may be generated in this way is high, depending on the kinetic energy of impacting weight, the duration of this force is very short, fractions of a second. Dynamic moulding is the term used to refer to the compaction processes of impact and repeated impact (vibration). Very little work has been done in the field of soil-cement block forming

to investigate this method of compaction even though it appears to have potential advantages over quasi-static compaction. Research into dynamic compaction has been confined to rammed earth walling. In this type of construction the soil-cement mix is compacted either by a manual or a pneumatic ramming implement. The mix is placed inside solid shuttering and hence may be imagined to have considerably less lateral confinement than would be the case for block production. The data published in this field deals with the selection of ergonomic rammer heads such that the operator may continue to work for extended periods without diminishing compaction efficiency. This data is not transferable to the field of block compaction where hand or discrete pneumatic ramming would not be used.

Only one reference to block compaction by impact has been found, the work of Agas Groth (Groth 1984) conducted at the University of Warwick. This work showed that adequate soil-cement blocks could be made by impact-type dynamic compaction. This paper contained no firm information on how best to apply the impact blow or blows as only a small number of blocks were produced and the scatter in the results was too great. However this project did illustrate that blocks could be made by impact which were broadly similar to blocks compacted quasi-statically to 8 MPa. Agas's subsequent application of the technique to build two houses in Botswana in 1986 has not been documented.

The study of soil compaction techniques in the field of road construction and sublayer foundation preparation is somewhat more advanced, though still not completely understood. In particular, much attention has been given to the question of how best to compact a quantity of unconfined soil. The link between road construction and block making is likely to be moderately close, the major difference being that for road and sublayer foundation compaction the soil is not finitely contained, at least not to the extent of a rigid mould-box. From a study of this

literature there appears to be promise in methods of compaction other than by pressure, namely impact and vibration (repeated impaction).

One early study of the performance of soil compaction plant conducted by the Road Research Laboratory, Road Research Technical Paper No. 17 (Williams & Maclean, 1950) studied the differing effects and efficiencies of six soil compaction machines: three smooth-wheeled rollers, two sheepfoot rollers and one frog-rammer. The areas of the study which appear to be relevant to stabilised soil block production concern:

1. The number of passes of the plant required to bring the soil to a given degree of compaction, allowing a tentative estimate of process efficiency may be made.
2. The depth to which the soil may be compacted, and the degree of compaction reduction with depth, yielding a measure of the uniformity of compaction which may be expected.

The study was conducted with commercial compaction machines on a full size test track. Unfortunately the energy transferred to the soil by the machines was not quantified for each machine, in particular only the deadweight and base diameter of the frog-rammer machine were given, hence it is not possible to make a direct comparison on an applied energy basis. However general trends may be drawn if it is assumed that the machines are similar as suggested by Williams & Maclean.

The smooth-wheeled rollers may be considered to approximate to a slowly applied pressure which is repeated with successive passes. The sheepfoot roller may be assumed to be a somewhat more remote approximation to a rammed earth (Pise de Terre) method, repeated discrete loads or small impacts. The frog-rammer may be considered to approximate larger dynamic impact.

The number of passes required to bring a variety of soil types to various degrees of relative compaction were recorded graphically and subsequently compared.

The general trend for all types of machine tested was an initial rapid increase in dry density over the first few passes but thereafter the increase became progressively less. This is a corroboration of the work conducted by Lunt (1980), confirming that density increase diminishes with successive increases in applied compaction pressure.

The smooth-wheeled rollers gave full compaction (compaction to "refusal") between 8 and 16 passes depending on the type of soil in question. The frog-rammer gave full compaction with from 2 to 4 passes. The sheepsfoot rollers did not compact to refusal, additional densification was still apparent after 64 passes. It should be noted that for an unexplained reason one pass with the frog-rammer was equated to six with the other types of plant for the purpose of comparison. It is not at all clear from the text why this has been done, namely whether this was an attempt to equate compaction energy entering the ground or the total energy required for the complete operation, including the energy required for the necessary forward backward strokes to cover the same area as a roller type. However by examining the graphical results presented in the paper it could be seen that even equating one frog-rammer pass to six roller passes, the rate of increase of dry density falls in the same range as that for the other equipment. If a unity comparison is possible, namely equating one compaction coverage of the rammer to one pass of the roller then the rammer rate of density gain would exceed all others. Further the ultimate compacted dry density obtained with the rammer was consistently one of the highest for all of the plant over all the types of soil tested.

There was a correlation between the soil type and the more successful method of compaction. Both the non-plastic (granular) soils, sand and gravel-sand-clay were best compacted by smooth-wheeled rollers, while the most plastic (cohesive) soils, heavy clay, silty clay and sandy clay were best compacted by the sheepsfoot rollers. The frog-rammer was always just below the best compacting machine. Soil for soil-cement blocks would ideally lie between the two soil types mentioned above.

The results of the field experiments to determine the density of compaction at depth showed that the frog-rammer was consistently able to compact a considerably greater depth of soil with a smaller fall off in density with depth than any of the other types of machine. (A rapid reduction of dry density with depth was found for the other plant.) This indicates that more uniform compaction is apparently possible with impact than slowly applied pressure.

The above results then suggest that compaction efficiency by impact, may be of the same (or greater) order as that for pressure, as judged by the rate of density gain. If efficiency is regarded in terms of soil surface area compacted per hour, as it was for this paper, then the frog-rammer is considerably less efficient, due to its lower net forward speed. However as the rammer's compaction is deeper than the rollers', if efficiency were judged on volume of soil compacted the balance would change. In the case of stabilised soil block manufacture the efficiency would be judged in terms of the energy expended for the uniform compaction of a volume of soil and so impact would appear promising in terms of the uniform compaction with depth apparently obtainable. This supports the view that soil compaction may be successfully performed by methods other than slowly applied pressure. However it must be remembered that the soil tested was essentially unconfined perhaps allowing easier escape for air and free water than would be the case for a confined sample in a comparatively small mould. It would intuitively be the faster force application process, namely impact, which would be most affected by this. This factor could well negate the deep compaction benefit seen in road base construction, the trapped air perhaps acting as an elastic shock absorber.

A second area in which dynamic compaction has been studied in the construction industry is ground treatment by deep compaction. Within this group of techniques dynamic consolidation is the one of most interest for soil block production. Such consolidation has been used successfully to increase the dry density and

consequently the bearing capacity of many soils. A heavy weight, typically several tonnes, is dropped from a large height, typically 15-40m. The resulting "very high intensity" impacts have improved the soil mechanical characteristics to depths of 10-30m. The normal technique consists of dropping the mass over well defined intervals of time and space appropriate to the particular site character.

Two papers have been examined which deal with this method of compaction, "Theoretical and practical aspects of dynamic consolidation" by Menard & Broise and "Soil compaction by impact" by Scott & Pearce both contained in "Ground treatment by deep compaction" (I.C.E., 1976). Although these papers are again dealing with an essentially unconfined situation, where the movement of trapped gas and water may be significantly easier, some possibly relevant information may be gained from them. Menard's paper is primarily concerned with attempting to theoretically explain the practical aspects of the compression of saturated clay soil, a medium classically considered as incompressible when subject to rapid loadings, its low permeability opposing any rapid movement of pore water. Menard puts forward the theory that the observed compaction occurs as a result of the presence of micro-bubbles whose conditions of equilibrium are "more or less" (Menard) irreversibly modified by shocks or vibration. As energy is applied to the soil in the form of repeated impacts the gas gradually becomes compressed. As the gas volume approaches zero the soil starts to react as an incompressible material and begins to liquify. As a result of this liquefaction "a very slight local increase of pore-water pressure is sufficient to start a tearing of the soil tissues by splitting, and quite naturally the flow of liquid concentrates in these newly created fissures" (Menard). It is this apparent high permeability which would account for the escape of the pore-water and trapped gas. The regular pattern of tamping providing a network of these fissures sufficient to enable a general densification of the soil. It should be noted that these fissures are "created regularly around the impact points", not directly beneath the impact zone.

This theory, if correct, could then explain the greater penetrating power of the impact compaction devices in use for road base stabilisation. However compaction of stabilised soil cement blocks by impact may appear less attractive. If it is the creation of these fissures around the impact point which are responsible for the greater effect, then in the confined case these fissures may not form. Furthermore if they were to form within the structure of the block they could act as possible stress concentrators and hence reduce the strength despite an increased density.

However if the interface between the soil mixture and the mould could act as such a fissure then impact may be viable, the distance for any trapped gas to travel to an interface would be small for a typical block. If the soil-mould interface could act as a suitable fissure this would suggest that impact compaction may be better applied to the smallest face of the block thus allowing the smallest travel path, rather than the largest, as is currently the case. Indeed the primary drawback to "end compaction", the poor compaction of the lowest material due to poor pressure transmission in the case of slowly applied pressure would be overcome. Full advantage of the greater compaction depth seen with impact could then be taken. The pressure wave produced by the rapid deceleration of the weight is analogous to a concentrated band of energy and penetrates further into the medium than the more dispersed energy resulting from slowly applied pressure. However Menard's explanation leaves several uncertainties for the confined compaction of a loose essentially aerated soil, as would be the case for block making. Does the required increase in soil permeability depend on soil liquefaction and if so can an aerated soil be liquified at realistic energy levels? The key for block production by impact appears, from Menard's work, to be finding a suitable method of removing the majority of air entrained within the soil to allow full compaction. Complete removal of the contained air is not likely to occur without excessive energy application. However if the volume fraction of air is reduced, initially by expulsion and

subsequently by compression then the effective stiffness of the soil may be increased such that an applied shock wave may propagate unattenuated to a greater depth. The cohesive nature of soil used for soil-cement might then restrain the expansion of this highly compressed air, generating a pressure gradient which would result in continued air expulsion even after the applied pressure peak has passed.

A third area which was considered was the compaction of conventional concrete by vibration. However the conventional concrete compaction process is concerned with the removal of air from a viscous liquid. Vibration is used to reduce the viscosity of the concrete such that air migration becomes possible under the influence of buoyancy. Conventional concrete vibration is not relevant to the compaction of soil-cement, soil-cement is a much drier medium.

One author has been found who examines the compaction of semi-dry concrete for the formation of precast elements (Afanasjew, 1986). However this publication is only available in Russian, translation of which revealed that the information contained was somewhat confused and entirely empirical. It examined among other things the effect of decoupled vibration (small impacts) on submerged reinforcing bar but did not provide any relevant information for confined compaction of cement stabilised soil.

A large scale machine has been developed which compacts soil-cement blocks by pressurised vibration. This machine is called the Dynaterre and is produced by Ets Raffin (France). As reported in Mukerji (1988), the research for this machine was carried out by the School of Architecture of Saint Etienne. Unfortunately it has not proved possible to gain access to this work. Repeated requests have been made to CRA Terre for information relating to the operating parameters of this machine but these have not been successful.

1.3 THE STRUCTURE OF THIS THESIS

The preceding literature review has shown that the production system for stabilised soil-cement blocks is not fully understood. This thesis has been split into three parts, each of which deals with a separate aspect of production. The first, Part A, examines the general processes of soil selection and stabilisation. Part B analyses the process of compacting soil by slowly applied pressure (quasi-static compaction) and presents the results of the research conducted in this area. Part C puts forward dynamic-impact as an alternative method of compaction and presents the supporting experimental evidence.

1.3.1 *OUTLINE OF PART A (Chapters 2 and 3)*

The first issue which is addressed is the fundamental one of theoretical understanding of soil strength and stabilisation. If the users' theoretical understanding of the process is improved, then the need for care in soil selection and consistency in production methods should become self evident, and self perpetuating. This part of the thesis is concerned with assembling this theoretical information and presenting it in a useful format alongside practical details of its application.

Chapter 2 explores what gives unstabilised soil its dry strength and how successful stabilisation, by whatever path, allows some strength to persist even if the soil becomes completely saturated. The most common methods of stabilisation are examined and an explanation of how certain soils are best suited to certain types of stabilisation is given.

Cement-based stabilisation is then examined in more detail, paying special attention to the much misunderstood concept of optimum moisture content and the effects of too dry or too wet a mix. Soil mixing, batching and mould filling are also examined to assess the degree of care which must be exercised in these operations to

achieve a uniform quality and maximum benefit from the added stabiliser. A similar discussion of soil compaction, block ejection and curing is given. It is shown that a process which on first sight appears to be very simple is in fact highly dependant on skilled implementation for success.

By examining soil stabilisation in this theoretical way, it was hoped that a more unified understanding of soil stabilisation techniques, in particular those applicable to cement stabilisation would be forthcoming.

Chapter 3 examined the soil itself and methods of selecting a suitable soil. As soil is the major constituent of a soil-cement block it is important that the most appropriate soil available is selected. With a comprehensive set of field tests and a good understanding of the role of each element of the soil constitution, the number of soils used for any trial block production run may be greatly reduced by rejecting less suitable soils at an early stage.

It was found that descriptions of field methods of soil testing in the literature were confusing and on occasion incorrect, the drop test has already been sited above as one such example. Chapter 3 surveys the published criteria for suitable soils and examines the reported soil tests, highlighting methodological errors and areas for caution. This chapter concludes with a proposal for a unified testing procedure, illustrating how these tests may be best combined to maximise efficiency and minimise experimental time. Such a unified testing plan has been universally omitted from the published literature.

1.3.2 OUTLINE OF PART B (Chapters 4 and 5)

Part B of this thesis presents the results of a scientific study of the quasi-static compaction process. Quasi-static compaction is the most common production method for soil-cement blocks and yet none of the literature which has been examined has attempted to describe the mechanisms behind it. Moreover the effects of relatively

simple variations to the moulding process are unknown. Both physical mould variations such as mould-wall friction and process variations such as pressure cycling might improve the efficiency of compaction, by increasing the compacted density resulting from a given compaction pressure. If simple process variations could provide the same benefit as higher pressure compaction then production economics could be easily improved.

Chapter 4 examines the effects of variations to the quasi-static moulding process by examining both the variation in pressure transmission through the soil and the overall gain in density. In this way the subsequent study of dynamic compaction in Part C has a fixed reference against which to be judged. The study of process variations also allows recommendations to be made concerning machine design.

The theory of the compaction process is also addressed. A number of simple models are put forward to describe the compaction process and then compared with the experimental results observed to assess their accuracy.

In order to assess the real economic benefit or disadvantage of the high pressure quasi-static compaction route advocated by Lunt (1980), the relationship between compaction pressure, cement content and final wet compressive strength is examined in Chapter 5. By producing a mathematical relation which allows the compressive strength of a certain soil to be predicted from its compaction pressure and cement content, an economic analysis can be constructed. This model can then be used to investigate the financial saving resulting from reducing the cement content as a consequence of using high pressure compaction and compare this with the increased capital cost of a high pressure machine.

1.3.3 OUTLINE OF PART C (Chapters 6, 7 and 8)

Part C addresses dynamic compaction. The research conducted in part B indicated that there are advantages to high pressure compaction but that at present the

high machine cost of quasi-static compaction machines outweighs them. Dynamic impact compaction is one method of generating very large forces, without requiring that a high force is sustained. It is likely that for a given degree of compression an impact-based machine would be less expensive than quasi-static one and hence might allow the practical advantages of high pressure compaction to become financially beneficial.

This Part examines the process of impact compaction to establish whether it can produce compacted samples of density equivalent to that produced by high pressure quasi-static compaction and whether the energy expenditure is broadly equivalent. The TRRL report has indicated that there may be additional benefits associated with impact compaction such as a more uniform density distribution resulting in a higher compressive strength and durability for a given total density. Chapter 7 examines the process of dynamic compaction, comparing energy, density and compressive strength with those occurring under high pressure quasi-static compaction. It establishes the potential merit of dynamic compaction. It examines the significance of impact blow momentum and energy on final compacted density and puts forward theoretical models to extend the understanding of confined dynamic compaction. Chapter 8 presents a computer simulation which is able to confirm some of the pertinent factors relating to the theoretical models put forward to describe dynamic compaction.

Chapter 9 is the final section of the thesis. It presents the conclusions from each Part of the thesis and argues the case for further research. The most pressing areas for future work are then identified.

PART A:

SOIL STABILISATION

CHAPTER 2

SOIL STABILISATION METHODS AND MECHANISMS

2.1 UNSTABILISED-SOIL WALLING

2.1.1 INTRODUCTION

Naturally occurring soil is one of the most variable materials known. It is made up by five main solid fractions, organic matter, clay, silt, sand and gravel, besides air and water. Organic matter is the decomposed remains of vegetable material and is normally only present in the top stratum of soil. Gravel, sand, silt and clay form bands in a size continuum¹. Gravel and sand are generally referred to as the coarse fraction while silt and clay are termed the fine fraction. Gravel, sand and silt are usually chemically inert products of the mechanical weathering of rock, while clay is usually the product of chemical attack and is able to take part in ion substitution reactions². The large variation in soil characteristics is a result of the differing chemical compositions and angularities of these different size fractions which vary with the type of parent rock from which they originate. The percentage shares of a

¹. A number of different particle sizes have been used to define the break points between gravel, sand, silt and clay. The standard used in this thesis is British Standard 1377.

². Silt may be considered to have some cohesive properties but these are usually negligible compared to the clay fraction.

soil's constituent fractions is collectively known as the soil grading³, a well graded soil has similar quantities of each of the fractions, while a poorly or gap graded soil has one or more dominant fractions.

The primary drawback to building with raw unstabilised earth is its low resistance to water. Soil loses its strength and swells rapidly on exposure to water. The underlying mechanism is best understood by examining the physical changes a plastic soil undergoes in drying from a wet saturated liquid condition to a dry state.

2.1.2 THE EFFECT OF WATER ON UNSTABILISED SOIL

A saturated soil in a "liquid state" is one which cannot support a shearing force without flowing. The soil particles are separated by free water. This water fills the inter-particle voids within the soil and effectively acts as a lubricant. If a force is applied to a soil in such a state it will flow, the soil particles sliding over each other.

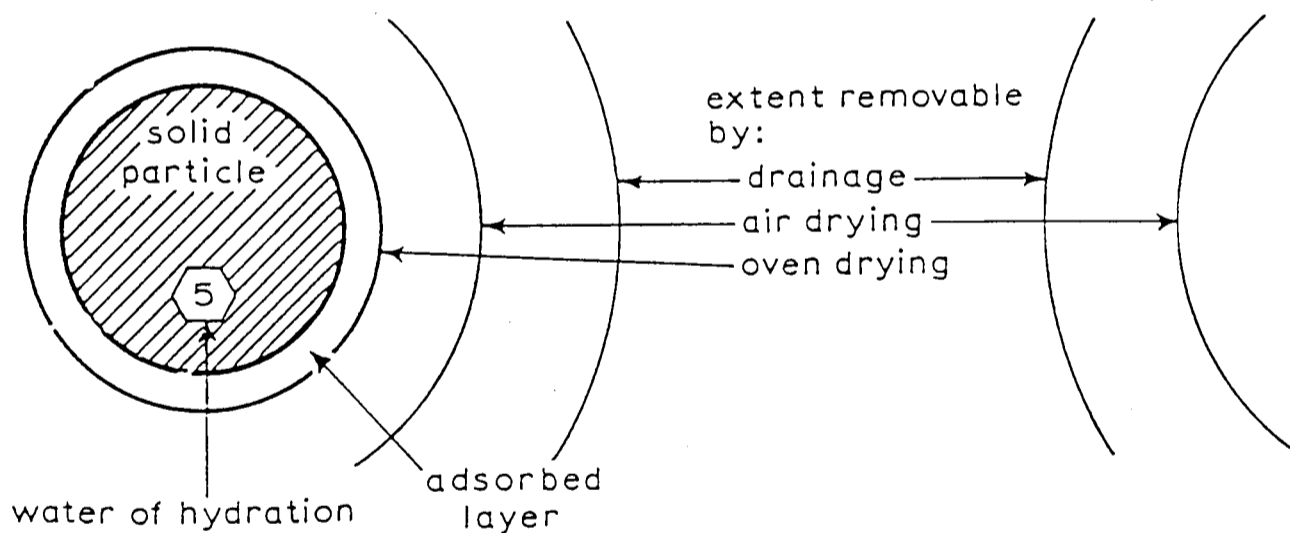

Figure 2.1.2 Water layers surrounding a clay particle

³ The organic content of a soil to be used for building should be approximately zero. Organic soil is unsuitable for construction and should not be used. An organic fraction will not be detected by particle size analysis and hence will not be shown in the soil's grading. Grading is also unable to identify the soil's chemical composition, certain (e.g. lateritic) soils are slightly chemically active and this can affect their behaviour.

As a saturated soil dries from the liquid state to the plastic state the volume of inter-particle water decreases. For a soil-water system the adhesive force between a water molecule and a soil grain is higher than the cohesive force between two adjacent water molecules. This adhesive force between the water and the soil particles gives rise to a tension effect in the pore water which effectively pulls neighbouring soil particles closer together until the attractive force is balanced by a contact force between touching soil grains. The contact force generates a degree of friction between contacting grains, giving the soil an apparent cohesion without a rigid bond system. The soil now has some resistance to shearing forces and can be moulded or non-elastically deformed without fracturing. This is defined as the plastic state. As more water is dried off this tension effect becomes greater and the soil becomes progressively more rigid and less plastic⁴.

As a plastic soil continues to dry, it reaches a point where the bulk of the pore water has been removed and no further shrinkage occurs (the shrinkage limit). The soil grains are considered to be in a state of intimate packing, the voids between them just filled with water. Drying beyond this point allows air to enter the soil pores, in effect producing water drops at the points of contact and increasing the air/water surface area. During further drying the number of air filled pores increases. It can be imagined that the increasing water surface area leads to a net increase in the surface tension force, increasing the inter-particle contact friction. Even when thoroughly oven dried (105 degrees centigrade) micro-droplets exist at the points of contact between clay particles as a result of the presence of the adsorbed⁵ water layer.

⁴. The change from liquid through plastic to solid is a continuum. The defined boundaries are artificially fixed by standard tests.

⁵. Clay particles normally exist with a net electrostatic charge as a result of ion substitution. The degree of substitution varies with the clay type and the surface area of the individual clay particles, kaolin in general having a lower tendency for
(continued...)

Any attempt to deform this more strongly bound solid soil results in cracking. This mechanism does not appear to explain the retention of dry strength by clays even up to the temperature of decomposition. The adsorbed water will remain at oven drying temperatures (105-110 degrees centigrade) but even this should be driven off before the clay decomposes. A further extension to this model is possible to provide a more complete explanation. As the last layer of water molecules is removed, at high temperature, the electrostatic forces of repulsion between the particles cease to exist and are replaced by very short range Van der Waal type forces. This electrostatic model is supported by the fact that when non-polar liquids such as xylene or petroleum ether are substituted for the simple dipole water, neither plasticity nor dry strength develop.

2.1.3 SOIL PROPERTIES AFFECTING STRENGTH

The clay fraction of the soil acts like a glue which holds the larger fractions together on drying. Sand and silt sized soil particles do not generally possess an adsorbed water layer as they are not normally electrostatically charged. When a pure sand sample is dried it will not display any significant plasticity and its slight cohesion will be lost as the water evaporates. The dry compressive strength of a soil can now be seen to depend on two factors; the overall soil grading or the number of points of particle contact (packing density) and the type and percentage of clay present.

For a given percentage and type of clay a stronger structure will result from a well graded soil than a gap graded soil as the packing density will be improved. For any soil grading an increase in clay content will increase the dry strength of the soil. Similarly the greater the specific surface area of the clay, which varies according to

⁵(...continued)

substitution than montmorillonite. The higher the net electrostatic charge then the more strongly held the adsorbed water layer.

clay type, the greater the number of potential sites for ion substitution, increasing the dry strength by increasing the number of electrostatic bonds. Head (1980) reports that the approximate surface area of fine sand and medium silt are 0.023 and 0.23 square metres per gram while for three major clay groups, kaolinite, illite and montmorillonite this increases to 10, 100 and 1000 square metres per gram respectively. The large difference in surface areas between these clays should then be expected to play a significant role in the final strength and explain the differing degrees of plasticity and expansion on wetting exhibited.

If a dry soil is exposed to water then capillary suction quickly draws water into the body of the soil, rapidly reducing the cohesive force by increasing the size of the water droplets at the points of contact, thus allowing the soil to soften and subsequently swell. The amount that a soil will swell is primarily dependant on the type and quantity of clay present. Clay usually exists in small agglomerations which expand in three dimensions on wetting as water penetrates some of the numerous individual particle boundary fissures. As the soil swells it passes back through the plastic and ultimately to the liquid phase with the corresponding loss of strength. The rate of loss of strength depends on the time taken for the water to penetrate the soil, a less permeable soil will withstand water attack for a longer period of time but if the exposure is sufficiently prolonged ultimate collapse will follow.

A soil wall's susceptibility to water results in the poor performance of such structures wherever they come into contact with water. On repeated wetting and drying cycles the exposed sections of wall will crack and spall, the external surface expanding and contracting at a different rate to that of the main body, thus rapidly deteriorating the surface finish and eventually reducing the load bearing capability. An unstabilised soil wall exposed to water will require frequent labour-intensive maintenance.

2.2 STABILISED SOIL WALLING

2.2.1 INTRODUCTION

There are many methods to reduce a soil's susceptibility to weakening by water. These fall into the following broad categories:

- protecting the wall from exposure to water through improved building design and surface rendering
- reducing the permeability of the wall by increasing the soil density
- making the soil water-repellant by the addition of a water-proofing agent
- providing a secondary cementitious-type strength mechanism which is largely unaffected by water

2.2.2 IMPROVED BUILDING DESIGN (ARCHITECTURE)

The simplest method to improve a soil wall's performance is to protect it from exposure to water by using more suitable building designs. Large eaves overhanging by one metre or more will help to reduce the amount of rainwater hitting the wall. A stone or concrete footing, extending above ground level, will protect the base of the wall from rain splashing back from the ground. A simple damp course will stop capillary suction from drawing any ground water into the wall. This is a short list, for a more detailed account of such possible improvements see CRA Terre (1979) and Lawson (1992).

These improvements do not affect the wall's susceptibility to water but simply reduce the chance of water contact, as such they should be used wherever possible to supplement any of the other methods mentioned below.

An allied technique is that of surface rendering. A good surface render will reduce the permeability of the external faces of the wall and protect the wall's surface

from direct erosion. The render will erode but can be reapplied as required. Render adhesion to the underlying wall is frequently a problem for low strength stabilised-soil walling (compressive strengths less than 1 MPa). The render does not prevent the underlying wall from becoming wet if rain exposure is prolonged, consequently the wall may still expand and contract. If the expansion characteristics of the render differ from those of the wall this causes the render to flake away prematurely. This flaking is lessened on higher strength walling where the dimensional stability of the wall on wetting is greater. Unfortunately it is the low strength walling which is in greatest need of the durability improvement provided by rendering. High strength walling is frequently adequately durable without rendering.

It is frequently debated whether it is preferable to construct with cheap low strength walling and subsequently apply a render coating, accepting the ongoing cost of render maintenance or to construct with more expensive but more durable higher strength walling and omit the render coating entirely. This issue has not been adequately addressed by the literature and is beyond the scope of this thesis. However it should be noted that increased material costs associated with higher strength blocks may be offset against the savings made by omitting a render coating, without necessarily adversely affecting the durability of the building.

2.2.3 INCREASED DENSITY

As the density of a soil wall increases then the number of points of particle contact increase and both the void size and the number of connected voids reduce. The larger number of points of particle contact increases the load bearing capacity of the soil while the reduced number of connected voids reduces the soil's permeability. An increase in density thus increases both the soil's dry strength and the time taken for it to absorb any water to which it is exposed. The reduced permeability slows

down the absorption of water hence increasing the wall's durability but it does not change the effect of the absorbed water; cracking, spalling and ultimately collapse.

The soil density may be improved by selecting a better graded soil and/or improved mechanical compaction. A well graded (and well mixed) soil will provide a more densely packed mass, progressively finer soil fractions can fill the voids between larger particles.

Mechanical compaction may apply a higher force to the soil than simple hand compaction, so that it may be compacted in a drier condition. The applied mechanical force overcomes the increased friction and forces the particles to move into a more closely packed arrangement by displacing the void air. Mechanical compaction is not normally able to expel water from the soil pores. Hence the correct water content is vital as either too much or too little water will result in a less dense product. For a given compaction force applied to a given soil, too little water will result in increased soil particle friction resisting the compaction force before the majority of the void air has been expelled. Too much water will also result in a less dense structure as although the majority of the void air will be expelled the soil particles will be at least partially separated by the excess void water which is considered incompressible and cannot be expelled without sophisticated filtration equipment and very high compaction pressures. Mechanical densification may be used by itself or with any waterproofer or cementitious stabilising agent. When cementitious stabilisers are used it is normal to compact the soil in order to gain the most dense structure and hence minimise the quantity of stabiliser.

2.2.4 WATERPROOFING

When soil is mixed with a bitumen emulsion it becomes water-repellant. The degree of water repellency exhibited depends largely on how many of the soil's particles become emulsion coated. Bitumen reduces the passage of water by virtue

of water's low adhesion with it compared to that with sand, silt or clay. The reduced water adhesion reduces the capillary and surface tension effects which in turn lowers the soil's capillary suction. The waterproofed nature of the soil then enhances the durability of the wall. However reduced adhesion often results in lower dry strength for fine materials which rely on the micro-droplet dry strength mechanism.

For bitumen stabilisation to be successful a high percentage of the soil particles should be coated, as uncoated linked voids will provide a water transportation channel around which local softening and swelling will occur. For fine clay and silt-based soils the quantity of bitumen emulsion required to produce significant improvement may frequently be uneconomically large as a result of the high specific surface area of these fine components. Hence bitumen is predominantly used for granular soils with low silt/clay contents which would normally be unsuitable for construction because of their low dry strength. In such soils bitumen emulsions may actually improve the dry cohesion and wet strength by "sticking together" larger size soil grains which would otherwise be only loosely held by weak surface tension effects⁶. The dry strength of such a stabilised granular soil is frequently very close to and dependant upon the strength of the bitumen. In tropical countries this may present a problem when the wall becomes hot. As the bitumen heats up the wall surface becomes soft and sticky and may stain anything which brushes against it. In severe high temperatures the wall may even be seen to sag.

To enable adequate mixing the bitumen is usually heated and dissolved in a solvent such as kerosene and subsequently formed into an emulsion with water. If the soil to be stabilised is local and "free" the cost of the process is largely dependant on the cost of the kerosene, the bitumen and the chosen heating fuel. If cheap indigenously produced bitumen is not locally available then this method of

⁶ As mentioned above surface tension forces are low for granular soils as these have a comparatively low specific surface area.

stabilisation may rapidly become alarmingly expensive. Moreover because the quantities of kerosene and water required to make the bitumen sufficiently workable to allow uniform mixing are quite large, the final soil wall may frequently have a lower density and consequent higher porosity than would be the case for other stabilisation methods.

2.2.5 CEMENTITIOUS BINDERS

Introduction

Three types of cementitious binders have been commonly used, *ordinary portland cement, lime and pozzolanic mixtures*. All three serve the purpose of wet strength improvement and reduced expansion on wetting by forming a system of cementitious bonds which are unaffected by water. The precise mechanism by which a small (up to 10%) content of cementitious binder can drastically alter the soil's properties is not fully understood. Ingles and Metcalf (1972) report that ordinary portland cement is thought to form either strong nuclei distributed throughout the soil mass or a hard skeleton throughout the soil voids in such a manner that the unaffected soil is restrained, in both cases the material formed is an insoluble hydrated calcium silicate. Analysis of cured soil cement by electron microscope generally shows a large number of fibre like cementitious filaments in a randomly interlocked matrix, supporting the skeletal theory.

The production method for each of the three cementitious stabilisers is the same. A suitable quantity of stabiliser is added to a known quantity of dry soil and thoroughly mixed. Once dry-mixed, a suitable quantity of water is added to the mixture and re-mixed. The resulting damp soil mass is then formed into wall components by compaction. The compaction is performed either by a Cinva Ram type of block press, producing blocks which are then cured before use, or by tamping the

soil within constraining shuttering to form a wall directly (Pise de Terre), curing in this case being done in situ.

Ordinary portland cement

Ordinary portland cement is made up of 45% tricalcium silicate (C_3S)⁷ and 27% dicalcium silicate (C_2S). In the presence of damp soil these components hydrate to form mono and di-calcium silicate hydrate gels (CSH and C_2SH). These gels then slowly crystallise into the interlocking matrix.

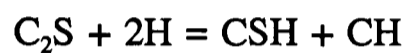
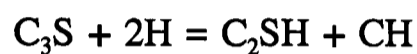

The free lime (CH) released then reacts further with the clay fraction (pozzolanic reaction) by the removal of silica from the clay minerals and subsequently forms more calcium silicate gel which gradually crystallises. The secondary pozzolanic reaction takes significantly longer to occur and will not usually contribute significantly to wet strength until 60 days of curing have elapsed.

Lime

Lime stabilisation produces a similar network of interlocking calcium silicate hydrate fibres however the formation mechanism is different. Lime is normally used for predominantly clay-based soil. On the addition of lime it reacts with the clay minerals by removing silica (as for cement above), or with any other fine pozzolanic material, eg hydrous silica. The lime stabilisation process proceeds more slowly than that for cement as the silica first has to be removed from the clay fraction. The removal reaction has the further effect that the overall reaction rate is to a degree

⁷ C and S here follow concrete convention and refer to calcium and silica respectively. The equations are simplified and do not represent fully balanced chemical reactions.

dependent on the clay type present and the ease with which this clay will give up silica.

Over a longer time period any unreacted lime will carbonise, reacting with atmospheric carbon dioxide to form calcium carbonate. This carbonation is of less relevance to wall construction as it is the strength of the material at the time of construction which is important. The carbonation reaction may well continue for 50 to 100 years.

Pozzolan mixtures

Pozzolan mixtures are formed by mixing pozzolanic material; burnt clay, rice husk ash, blast furnace slag etc., with lime and adding the resulting mixture to the soil to be stabilised. The pozzolan provides the silica necessary for the formation of calcium silicate. As the silica is more readily available to react with the lime the setting and curing times are brought closer to those of cement. The lime also reacts with the soil's clay fraction, as above, and again carbonises slowly over time.

2.2.6 SUMMARY OF STABILISATION METHODS

Any of the methods mentioned above may increase the strength and durability of a soil wall when correctly used. The building design modifications suggested are independent of the actual type of walling used. Improved building design should always be encouraged as the costs involved are usually low and there is always an improvement in durability when a wall is sheltered from water.

Increasing a soil wall's density will increase its dry strength and reduce its permeability hence increasing its durability. However the improvement gained without the addition of a stabiliser is not sufficient to make such a wall fully comparable with burnt brick or concrete walling. With the addition of a suitable stabiliser and adequate densification full comparability may be achieved.

Waterproofing methods of stabilisation rely on a suitable local supply of bitumen and kerosene which are sufficiently cheap. These materials are frequently not indigenous to the Developing World and in consequence may be expensive. In areas where bitumen cutback is available as a cheap byproduct of petroleum distillation then the generally lower strength resulting from such stabilisation techniques may be acceptable. In other areas where such material costs are high, cementitious-based stabilisation is likely to be more appropriate.

Cementitious stabilisation in combination with densification gives soil both wet strength and erosion resistance. Ordinary portland cement is the most commonly used stabiliser and at present usually the cheapest. Lime and lime-pozzolan stabilisation are growing in popularity because, unlike cement, lime may be produced economically by small-scale batching kilns. However, at present the quality of lime produced by such small-scale kilns is highly variable and liable to change from one batch to another. Moreover, a system of price subsidy exists in many countries so that cement remains cheaper than lime even though cement is more costly to produce.

At present it appears that the material with the greatest chance of success in terms of widespread applicability and quality of the stabilised product is soil stabilised with cement.

2.2.7 CEMENT-STABILISED SOIL WALLING

Cement-stabilised soil walling may be either rammed in situ (Pise de Terre) or laid with pre-formed blocks. The prime advantage to monolithic walling is that curing of the soil-cement mixture takes place in situ. The prime disadvantages are that monolithic curing can result in shrinkage cracking and that quality control is difficult. Shrinkage cracking of the wall during curing causes structural weakness, providing areas of local high permeability and sites of shelter for disease vectors. The equipment required for non-destructive quality testing is expensive and not likely to

be available. Hence destructive testing of a monolithic wall is likely to be the only reliable method of quality testing. This is not desirable, particularly so as most standard testing procedures require the stabilised mixture to cure for at least seven days prior to testing.

The prime advantages of pre-formed blocks are the increased compaction pressure possible by mechanical in-mould forming and that any shrinkage occurs during curing before the block has been laid in the wall, so cracks in the wall do not occur. Moreover destructive quality checking may be carried on sample blocks from each batch prior to use. The disadvantages of pre-formed blocks are the expense of the compaction equipment (particularly for high pressure compaction) and the flat level area of ground required to lie out the blocks during curing. However if the soil selection and block compaction processes are refined to maximise the strength of freshly demoulded blocks and minimise shrinkage during curing, then it may prove possible to lay blocks directly onto the wall without lengthy curing. Again quality control would remain more simple than in conventional monolithic walling. Provided the correct cement content is ensured, cured strength will depend on the block density and curing procedure. Block density may be checked on demoulding and curing should be improved as the blocks should be less susceptible to drying out, the surface area to volume ratio would be effectively reduced.

For this thesis soil-cement block production has been selected as the technology for study although much of what has been examined is also appropriate for monolithic walling.

2.3 PRODUCTION AND CURING OF STABILISED SOIL-CEMENT BUILDING BLOCKS

2.3.1 INTRODUCTION

Soil-cement is produced by dry-mixing a suitable soil with a small quantity of cement and re-mixing the product with a specific quantity of water (to get the optimum moisture content). From the resulting damp soil, batches are taken to be placed in the mould, compressed, ejected and subsequently cured for 4-7 days without being allowed to lose the water present during compaction. Finally the blocks are left for ideally a further two weeks to continue final curing, towards the end of this period they may be allowed to slowly dry before incorporation in a building.

The production method detail depends upon the equipment and soil used. Prior to production an extensive testing procedure must be conducted. The soils available for use should be tested to determine their characteristics so that the most suited soil or blend of soils is used. Once the soil is fixed then the compaction equipment to be used should be decided⁸. Differing compaction equipment compacts the soil-cement mixture to differing moulding pressures. Both the optimum moisture content and the cement content are affected by the compaction pressure used, moreover the optimum moisture content is also affected by the quantity of cement used. Hence for process optimisation empirical testing is required.

2.3.2 OPTIMUM MOISTURE CONTENT

Any soil placed in the mould for compaction should contain a known quantity of water. Earlier literature on the subject has suggested that there exists an optimum moisture content (OMC) at which the maximum density of the soil may be reached.

⁸. Alternatively if the compaction equipment is known then a soil suited for use with this machine should be found.

This is correct. By definition the resulting cured dry density will be highest for a block which has been compacted at its OMC. It should be forcefully noted however that the OMC is not a parameter solely dependant on the soil, it varies considerably with the compaction pressure used to form the block. In general, as the compaction pressure increases so the OMC decreases. The moisture content may be conveniently thought of as a lubricant which has adverse effects in excessive quantities. At higher compaction pressure the applied force is greater, the soil particles will move more readily and hence less lubricant (water) will be required.

The sensitivity of any particular soil to moisture depends on the soil's particular composition. The enormous range in particle size from gravel (6mm) to clay (less than 0.002mm) results in a large difference in the specific surface area (SSA) of soils containing different proportions of different sized particles. When a soil is made up of predominantly fine material then the SSA of that soil is very large. For a high SSA soil, a small change in water content will have little effect on the compaction process as the area over which the water acts will be relatively large and result in only minor physical change. Conversely for a low SSA soil, the area over which the water acts is reduced and hence the physical effect on the soil is greater.

This effect is illustrated in figure 2.3.2a. Dry density after compaction is plotted against moisture content at the time of compaction. Curve A shows the pattern for a well graded soil containing a range of particles from gravel to clay size, Curve B shows the pattern for a more

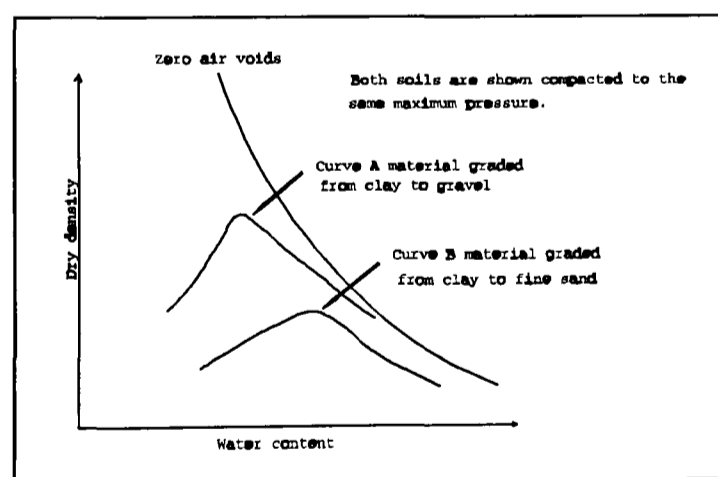

Figure 2.3.2a Dry density plotted against water content.

narrowly graded soil containing particles from only fine sand to clay size. It can be easily seen that curve A has a more pronounced peak than curve B. It may also be

noted that the density peak for curve B is shifted towards higher moisture contents and that the peak dry density is reduced. The increased optimum water content would be expected from the above discussion of SSA while the reduction in dry density would be expected from the discussion on particle grading. Well graded soils including a substantial fraction of large-size particles will be more sensitive to moisture content variation than soils with smaller fractions of large-size material. The degree of sensitivity to change in moisture content is an important parameter to consider when producing blocks. If the soil material being used does contain a significant quantity of large-size material then the control of the moisture content is more critical.

At the outset of this research a number of tests were conducted to establish the optimum moisture content for *soil-A* (this soil was chosen as a standard for use with a variety of mechanical treatments). To this end a number of small cylinders were produced at varying water contents and at both 2 and 10 MPa. *Soil-A* was well graded and the largest size fraction was coarse sand. This type of soil was found to have a low sensitivity to water (it contained a negligible proportion of gravel-size material), resulting in a flat moisture/density curve. However as a result of the low aspect ratio of the cylindrical mould used, the soil strength required for successful demoulding was quite high. This emphasised the importance of "green strength" (i.e. strength immediately upon demoulding) from an early stage in the experimental proceedings. By lowering the moisture content at compaction, the green block produced will be stronger although the final cured strength will be lower. The extent to which the reduction in moisture content will reduce the latter depends on the nature of the soil. In general a more sensitive soil will show a larger drop in final strength as a result of the larger drop in compacted density. It is usually the case that

compaction above⁹ the optimum water content will result in a weak green compact. If this green compact is not sufficiently strong to allow handling on ejection then it is likely that the breakage rate both on ejection and subsequent transportation will be high. The OMC for *soil-A* at 10 MPa was found to be 8% and the cylinders became too weak to allow demoulding without the most careful and elaborate system at 10%!

Low green strength is one of the major problems for many block production systems. Indeed Lawson (1992) found breakage rates to be as high as 50% for blocks produced on a Cinva Ram type of machine in Nigeria. If an excessive green breakage rate is found then the water content should be reduced. It should be remembered that any block which has been broken on ejection or during handling operations is lost. It may not be broken up and recompacted, as the cement hydration reaction will have progressed to such an extent that the amount of remaining unreacted cement would be too low for adequate stabilisation.

The moisture content at the time of compaction also has an effect on the durability in terms of the blocks' permeability. It has been reported by CRAterre that

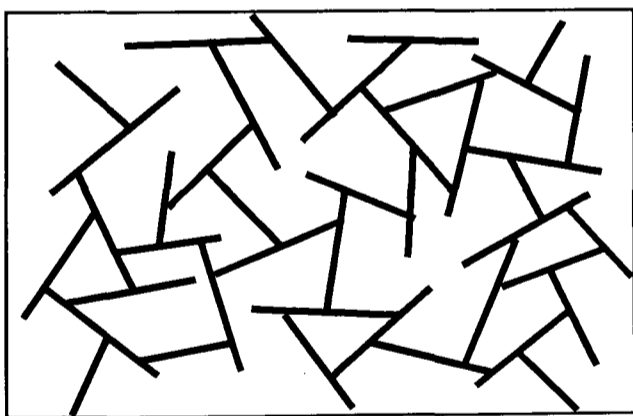

Figure 2.3.2b Flocculated structure

compaction at moisture contents less than the optimum will result in a more permeable structure than compaction above optimum. CRAterre use the concept of flocculated and dispersed microstructure to explain this phenomenon (Doat et al, 1979). At low

water contents the plate-shaped clay particles mutually attract each other. The outer edge of one plate electrostatically attracts the centre section of the neighbouring plates, leading to a flocculated clay structure (fig 2.3.2c). At high water contents, the surface charge of the clay plates is largely neutralised by the surrounding water dipoles and

⁹ With low clay content soils even compaction at the OMC may produce blocks with inadequate green strength.

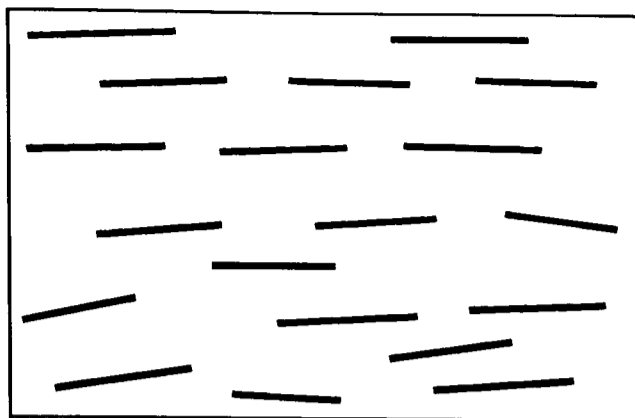

Figure 2.3.2c Dispersed structure

creates a pattern of mutually repelling particles or a dispersed structure (fig 2.3.3b).

However at present the magnitude of this permeability change is not clear. In wet climates where water penetration is likely to be of importance then compaction slightly

wetter than the OMC may be appropriate to increase the blocks' resistance to water.

In summary, compaction at the OMC will produce the most dense blocks (by definition). Compaction wetter than the OMC will produce blocks with a lower green strength on demoulding but possibly a lower permeability when cured. Compaction drier than the OMC will produce blocks with a higher green strength on demould but possibly a higher permeability.

Compaction at the OMC is normally the best compromise. However in dry climates and where low green strength has been seen to be a problem, the moisture content may be reduced. By contrast in wet climates where low green strength has not appeared as a problem then compaction at slightly increased moisture content may be considered. It should be remembered that the final cured strength of the block may be increased and the permeability reduced by increasing the cement content (although this may be costly) whereas the green strength may only be increased by improving the structure of the soil, compacting to higher pressure or reducing the moisture content.

2.3.3 SOIL MIXING, BATCHING AND MOULD FILLING

Once the soil, cement content and optimum moisture content have been determined then the amount of mix required for each block must be decided. With a fixed-volume type of compaction machine variations in the amount of soil used to

fill the mould will result in blocks of differing density, while with a fixed-pressure type of machine blocks of differing size will result.

The standard method of controlling the amount of material used per moulding operation is a gauge box of fixed volume. However this method can result in quite large variation in the mass of soil moulded. If the moisture content of the soil varies so does its specific volume. Thorough mixing is critical to batch homogeneity. If manual soil mixing is employed then the effort required for thorough mixing should not be underestimated and neither should the tendency for less thorough mixing to occur as the working day progresses. Although more costly it is desirable for quality consistency that mechanical mixing be employed; failing this care must be taken to ensure a uniform and consistent mix is obtained.

In tropical climates the water lost due to evaporation during the production process may become a significant factor. Large batch mixing has the advantage that block variation should be reduced, if well mixed. However large batches are significantly more difficult to mix homogeneously. Moreover the time between water addition to the batch and the moulding of the last block is significant as is discussed below. Large batch sizes increase the potential for moisture content variation within the batch and also reduce the final strength of the cured blocks as a result of wasted cement hydration.

The strength of the final cured block depends heavily on the adequate hydration of the cement. Cement is usually the most expensive ingredient in the production of stabilised-soil blocks. Ordinary portland cement starts to react immediately on coming into contact with water, the resulting fibres of insoluble calcium silicate hydrate skeleton extend throughout the soil voids. The fibres' effect is significantly reduced if they are deposited as discrete entities rather than as a continuous skeleton. Most of the fibres which form prior to the compaction of the soil cement mix will be broken during the pressing process and are then not as effective.

The most effective precipitation occurs after the compaction process when the soil particles remain undisturbed. As a result, the final strength of the stabilised block depends to a degree on the length of time for which the cement is exposed to water prior to compaction. Ingles and Metcalf (1972) have reproduced a graph from West which indicates that over 50% of the final strength of cement stabilised soil may be lost by a delay of 2 hours (Fig 2.3.3). Even after half an hour West indicates that between 30 and 40% of the strength is lost. A set of trials conducted by the author on cylindrical test compacts has failed to convincingly reproduce such dramatic results. This may be because the samples were too weak for adequate testing in the particular compression-test equipment available. However, a general trend was observed confirming some loss in (7-day) strength with increased delay between water addition and compaction. A 2 hour delay in compaction produced a strength loss of about 20%. Batch times in excess of one hour are unacceptable, times in the region of half an hour are more appropriate.

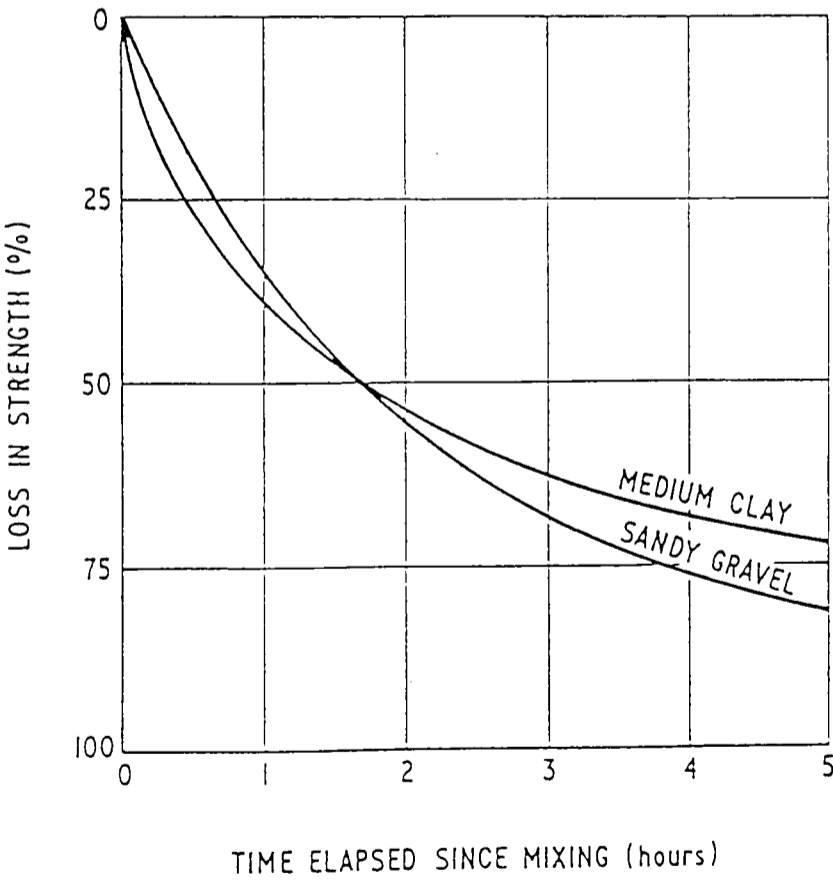

Figure 2.3.3 Cured strength loss due to compaction delay after West in Ingles & Metcalf (1972).

Occasional soil testing should be carried out during production to ensure that the soil being used has not changed significantly from the soil which was used for the initial pre-production trials. For example a slow gradual change in the clay content, which may occur naturally as the area of soil excavation progresses, may not be noticed by the person responsible for soil mixing and in extreme cases will cause substandard blocks even if all production processes are correct.

The method of placing soil in the gauge box also affects the amount of mass which is moulded. Gentle placement of loose soil mix will result in a much lower mass of mixture than tamping. For the purpose of this thesis all mould filling was conducted on a weight basis (although this requires the use of weighing equipment which will inevitably be more complex than volume measurement it is strongly recommended for field use).

2.3.4 SOIL COMPACTION, BLOCK EJECTION AND CURING

The detailed adjustment and operation of the moulding machine depends on the equipment used. If the correct amount and type of soil at the optimum moisture content is provided by the mould batching procedure then applying the same moulding force will produce blocks of constant density which will be dimensionally equal. If the operational method employed during moulding is inconsistent or the machine is poorly maintained or badly adjusted then either dimensional or density variations will be observed: dimensional variations will be seen with constant-pressure moulding machines while density variations will be found with constant-volume compaction.

Quality testing on block ejection is required to detect such variations. Dimensional variation is readily apparent on inspection however density variation can only be detected by weighing. If sub-standard blocks are the result of systematic error then remedial action may be taken immediately. If the blocks are only tested after curing (either at seven, fourteen or twenty eight days) then all of the blocks produced

by that machine during the chosen pre-test curing time are likely to be sub-standard and must be discarded. Quality control testing carried out on freshly demoulded blocks will drastically improve material wastage and reduce the temptation for unscrupulous producers to market the sub-standard blocks. It should be repeated that inferior blocks should not be broken up and recompacted, as the time from the first addition of water is likely to be excessive and significant cement hydration may have occurred.

If inadequate compaction goes undetected then high block breakage rates will occur and low strength will be seen in the cured blocks. If compaction quality control is omitted then it will not be clear whether low strength seen in cured blocks is as a result of poor compaction or poor curing. *Unstabilised-soil* blocks are allowed to begin drying out immediately after ejection from the mould. For *cement-stabilised* blocks the moulding moisture content must be retained for at least 4 days (up to 14 days if possible) to allow the bulk of the cement hydration reaction to occur: drying out of the blocks will stop the cementitious hydration reaction and hence not allow the blocks to gain their full strength.

The green blocks are weak until the chemical hydration reaction has occurred and any significant breakage rate will have an adverse effect on the economics of the project. The safest way to transport green blocks to the curing area is to place them on individual boards and subsequently carrying the board to the curing site. The blocks may be placed onto and removed from the board by placing the palms of the hands flat against the largest sides of the block and squeezing the hands together just enough to grip the block to lift it. The curing area should be a flat level area which must be protected from direct sunlight and rain. Direct sunlight would cause the blocks to dry out too quickly, while rain would easily erode the fresh blocks at least until the cement has had time to hydrate.

The strength of the freshly demoulded blocks depends on four factors: soil grading, clay content, moisture content and moulding pressure. Deficiencies in soil grading, clay content and moisture content should be found through pre-moulding quality control procedures. Moulding pressure deficiency should be found by quality checking the freshly ejected block. In this way the final wet compressive strength of the block will serve as an overall check on moulding and pre-moulding procedures as well as block-curing practice and correct addition of cement.

CHAPTER 3

SOIL TESTING FOR SOIL-CEMENT PRODUCTION

3.1 PROPERTIES OF SOIL FOR SOIL-CEMENT

3.1.1 GENERAL PROPERTIES

Using a suitable soil for soil-cement block production will result in:

- strong blocks, namely those that after curing possess high wet strength and erosion resistance
- handleable blocks, that immediately upon demoulding can be transferred to a curing area without a high breakage rate
- blocks which will not seriously distort or crack during curing
- blocks which will not expand and contract excessively in the building if subjected to wetting and drying cycles

Specifically disqualified soils are:

- those containing organic matter
- those which are highly expansive
- those containing excessive soluble salts e.g. gypsum and chalk

For building purposes soil can be generally characterised in two ways, by a particle size distribution analysis and by a plasticity index. The particle size analysis will give information on the soil's ability to pack into a dense structure and the quantity of fines present (combined silt and clay fraction), while the plasticity index gives an idea of the cohesion of the fines.

3.1.2 PARTICLE GRADING

The British Standard classification of soil particle sizes is given below:

coarse gravel	60 to 20 mm
medium gravel	20 to 6 mm
fine gravel	6 to 2 mm
coarse sand	2 to 0.6 mm
medium sand	0.6 to 0.2 mm
fine sand	0.2 to 0.06 mm
coarse silt	0.06 to 0.02 mm
medium silt	0.02 to 0.006 mm
fine silt	0.006 to 0.002 mm
clay	< 0.002 mm

Gravel larger than 6 mm is not usually used in soil-cement production, as the large particle size may lead to a poor (rough) surface finish. A suitable soil will contain a mixture of sand, silt and clay-sized particles. The proportions of each of these three fractions influence the properties of the block and will be discussed below.

A particle size analysis will determine the fraction of a soil's particles that fall within each of the above size bands. If a dense block is to be produced, it is important that the soil used is well graded. The theoretical distribution of particle sizes to provide a perfectly packed structure is called the Fuller curve. The Fuller curve is based upon the assumption that all of the particles are spherical and that the largest particles just touch each other, while there are enough intermediate particles

to fill the voids between the largest, but without holding them apart. The intermediate-sized particles are also similarly arranged with progressively finer particles filling the voids between larger ones. The Fuller distribution is an ideal model and never occurs naturally. However, a natural soil which has an even distribution of particle sizes, termed well graded, is a good approximation.

The value of a well graded soil for soil cement is that such a distribution of sizes gives a dense structure with a low specific surface area as mentioned in chapter 2. Moreover as the secondary cementitious strength mechanism depends on an interlocking calcium silicate matrix which extends through the soil voids, a more compact void system requires less cement to provide a matrix of equal efficiency. If it is imagined that cement coats the soil particles' surface, a high specific surface area will lead to cement blinding, or a lower specific surface area soil will require less cement to provide the same particle surface coverage and consequently the same strength and durability.

The upper and lower limits to the soil's grading also need to be considered. A soil may be considered well graded with a uniform distribution of particles from fine silt to coarse sand (coarse soil) or from clay to fine sand (fine soil). The coarse soil will have a lower specific surface area than the fine soil as the same mass of soil will contain fewer and larger particles.

From the above consideration of specific surface area, it might be concluded that the more coarse soil would produce strong blocks with a lower cement content than that needed for the fine soil. This is however only the case when the blocks are kept within the mould to cure. A coarse soil containing no fines (silt and clay) is non-plastic and will not have sufficient cohesion to retain its shape on ejection from the mould or to allow easy transportation to the curing area. If the blocks are left to cure in their moulds (and the moulds are made strong enough to withstand a significant compaction pressure) then the machinery costs escalate unacceptably. The coarse soil

could be considered to be a form of sand-cement containing large voids (a result of the lack of fines). Large voids would increase the porosity of the block and lead back to the common sand-cement problem of rapid drying before the cement has had time to adequately cure. Such a soil would be considered well graded but still be unsuitable for soil-cement block production. Conversely a well graded fine soil, containing little sand but a high clay content, would have a high specific surface area and expansivity (see below). The high clay content would give the soil cohesion and stability on ejection from the mould, but the high specific surface area would require a large amount of cement to provide a reasonable particle coverage.

Thus a suitable soil will be well graded but certain other conditions should also be satisfied: The largest particle size present should not be sufficiently large to cause a poor surface finish. Sufficient fines (silt and clay) should be present to allow handleability on demoulding but not enough to blind the small quantity of cement to be used.

3.1.3 PLASTICITY (FINES CONTENT)

The silt and clay content of a soil are responsible for soil cohesion and it is these fines which provide the fresh blocks with handleability until the initial set of the cement has occurred. The degree of cohesion provided to the block is dependant both on the fines present and the degree of compaction used to form the block. In general terms, a low-pressure moulding process will require a higher fines content than a high-pressure moulding process. This is because increased compaction will force the soil particles into more intimate contact, thus strengthening the fresh compact.

The fines also affect the final cured block's expansion on wetting. Clay usually exists in small agglomerations which expand in three dimensions on wetting as water penetrates some of the numerous individual particle boundary fissures. The expansion of the clay fraction must be largely restrained by the calcium silicate matrix

in order to minimise expansion and contraction of the cured block on repeated wetting and drying. Hence for durability the clay fraction should be as small as possible to allow the lowest cement content. It might be expected from the large difference between the specific surface areas of the three clay types mentioned in chapter 2 that different clays have significantly differing expansion characteristics on wetting. This is indeed the case: as the surface area of the clay fraction rises, so does the amount it will expand on wetting. Thus the type of clay as well as the quantity present will affect the block.

The fine fraction can be seen to be helpful to the block production process but to adversely affect the wet strength and durability of the final cured block. The quantity and type of clay should therefore be considered important soil parameters. The quantity of fines may be measured by using one of the sedimentation tests described later, however the clay type present is very difficult to determine without highly complex tests. In fact it is not necessary to know the clay type present but it is important to know the properties exhibited by the clay. The Atterburg tests defining liquid limit, plastic limit and plasticity index are used to quantify the plasticity of the finer fraction of a soil (only particles less than 0.425 mm are tested). These tests measure the percentage water contents at which the soil passes from a liquid state to a plastic state (liquid limit) and from a plastic state to a solid state (plastic limit). The numerical difference between the liquid and plastic limit (the plasticity index) thus gives the range of water content over which the soil may be considered plastic. As plasticity is dependent on the soil cohesion, it has been found that this index reflects the cohesive characteristics of the soil. Furthermore as cohesion is largely dependent on the specific surface area of the fines, these plasticity limits also reflect the expansivity of the soil. A soil with a low plasticity index will display low cohesion and usually low expansion on wetting, while a high index soil will display the reverse.

3.2 SUITABLE SOILS

3.2.1 OVERVIEW

From the preceding discussion we can characterise a suitable soil. It should not contain organic material or excessive soluble salts which would interfere with the setting of the cement. Its sand fraction should be well graded to provide a densely packed load-bearing skeleton for the block and its largest size particle should be small enough to give a smooth surface finish. The fine fraction should be just sufficient to provide enough cohesion to the fresh block to prevent damage on ejection and transportation from the mould. Too large a fines content will either require a large cement content for adequate stabilisation or will reduce the durability and wet strength of the final cured block. The cohesion of the fresh block will depend on the compaction pressure and moisture content used and the type as well as the quantity of clay present in the fines.

If the soil available on site appears unsuitable, it should be remembered that natural soil exists in distinct strata with differing compositions. If the different strata are adequately tested then it is a comparatively simple operation to mix suitable masses of two or more strata to produce an acceptable soil. Given the need to select at least a broadly suitable soil then the case for adequate soil testing should be clear.

3.2.2 SURVEY OF AVAILABLE CRITERIA FOR SOIL SUITABILITY

The following is a brief review of published selection criteria from other authors. It is not an exhaustive review but rather included as an indication of the variation between authors and as an illustration that such criteria should be used as a guide in initial soil selection rather than as a rigid set of rules. This variation is not surprising given the enormous variability of soil itself and the variation in production methods used by the different authors working in different climates. Some of the

authors recommend criteria based only on particle size while others use criteria based solely on the Atterburg limits (Plasticity Index). In general it would be wise to consider both.

Norton (1986). "Building With Earth, a Handbook".

Atterburg limit criteria for stabilisation:

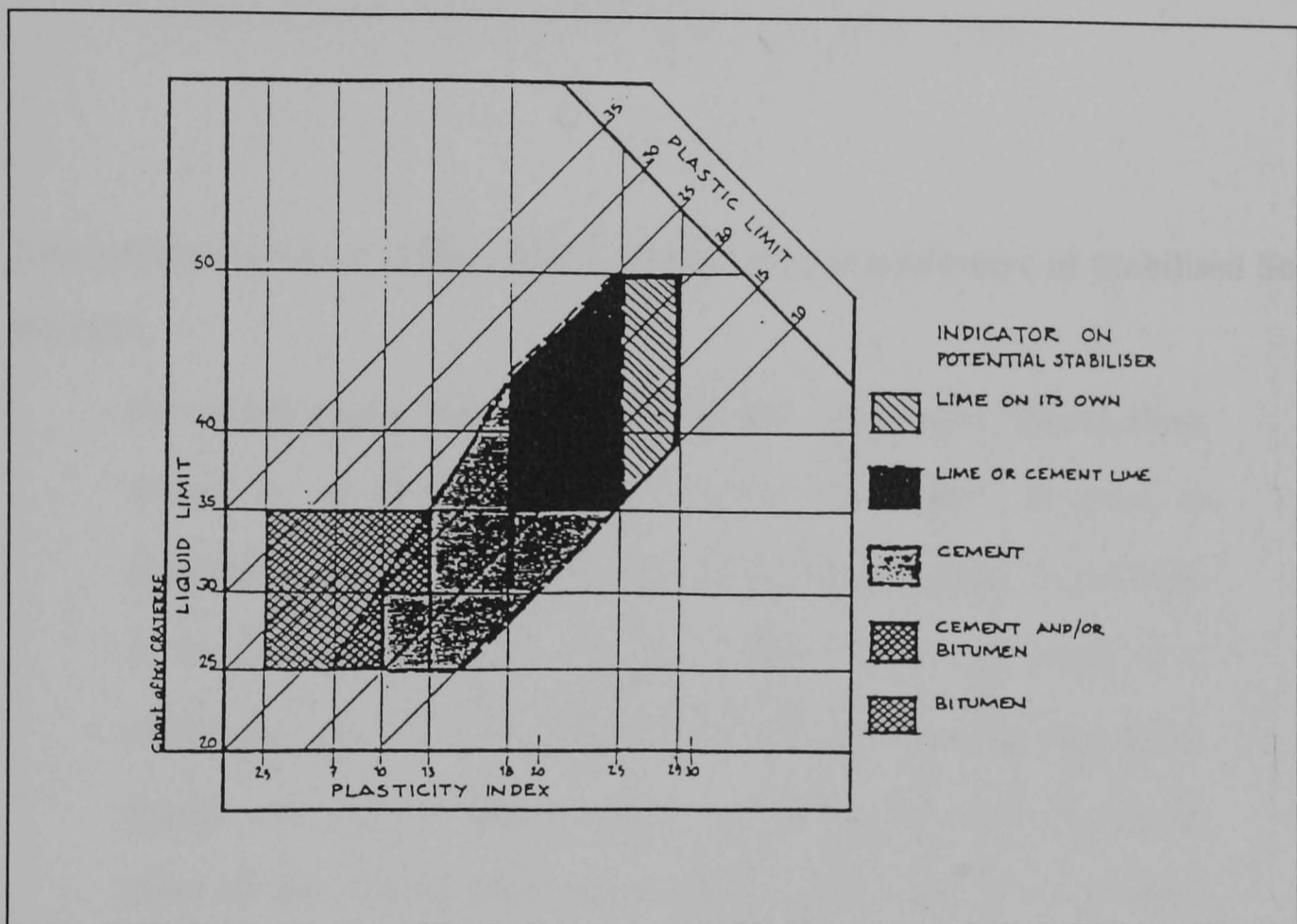

Figure 3.2.2a Interpretation of Atterburg Limits. Reproduced unmodified by Norton from a CRATerre original (Doat et al, 1972)

Particle size criteria for soil cement:

Optimum: no specific optimum, "should have a high sand content".

Limits : sand/fine gravel (<5-6 mm)	45 - 75 %
silt	15 - 30 %
clay	10 - 25 %
cement : variable	8 - 16 %

Not mentioned whether above is by weight or volume.

United Nations (1964). "Soil-cement, its Use in Building".

Particle size criteria for soil-cement:

Optimum: 75% sand
25% silt and clay, of which more than 10% is clay.

Limits: minimum of 45% sand. 55% silt and clay.
maximum of 80% sand. 20% silt and clay.

cement : variable, between 4.75 % and 12.5 % by volume.

International Labour Office (1987). "Small-scale Manufacture of Stabilised Soil Blocks".

No criteria is explicitly mentioned. Instead it is said that "Ideally, there should be an even distribution of each soil fraction in order to manufacture good-quality stabilised soil building blocks. If this were to be the case, about five per cent cement would be needed as a stabilising agent." The five fractions mentioned are: greater than 6 mm (coarse and medium gravel), greater than 2 mm (fine gravel), greater than 0.2 mm (coarse and medium sand), greater than 0.06 mm (fine sand) and less than 0.06 mm (combined silt and clay).

Fitzmaurice (1958). Contained in Spence & Cook (1983). "Manual on Stabilised Soil Construction for Housing".

Atterburg criteria for soils most suitable for stabilisation:

Liquid limit : less than 40 %
Plasticity index : less than 22 % and greater than 2.5 %

Fitzmaurice's note : primarily derived from temperate soils and only of limited application to tropical soils particularly laterites.

Stulz (1983). "Appropriate Building Materials".

Atterburg criteria for portland cement stabilisation:

- Plasticity index: 0 - 12
- Cement content: 6 - 10 % (down to 3 % for sandy soils).

Also "cement stabilisation of clayey soils (like red cotton soil) seems not to be useful".

Includes Atterburg three-axis graph by CRATerre (Doat et al, 1972). Identical to that used by Norton (1986) but without a similar key (Figure 3.2.2a).

Particle size criteria for compressed soil bricks:

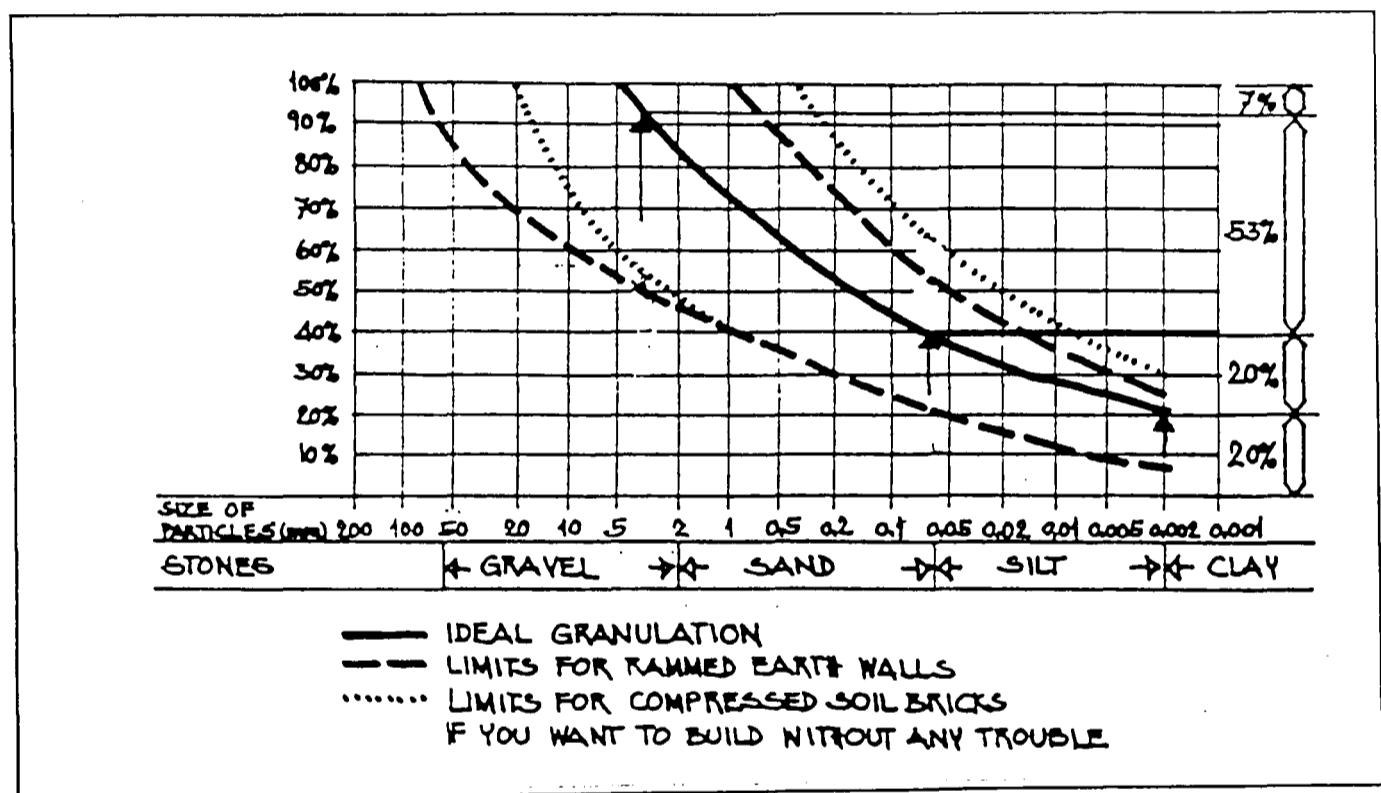

Figure 3.2.2b Particle size criteria granulation curve. Included in Stulz after CRATerre (Doat et al, 1972)

Spence & Cook (1983). "Building Materials in Developing Countries".

Particle size criteria for soil-cement:

Spence and Cook include a graphical plot on a triangular U.S. Bureau of Public Roads particle-size graph roughly between the limits:

sand: 90 - 60 %

silt: 25 - 0 %

clay: 25 - 0 %

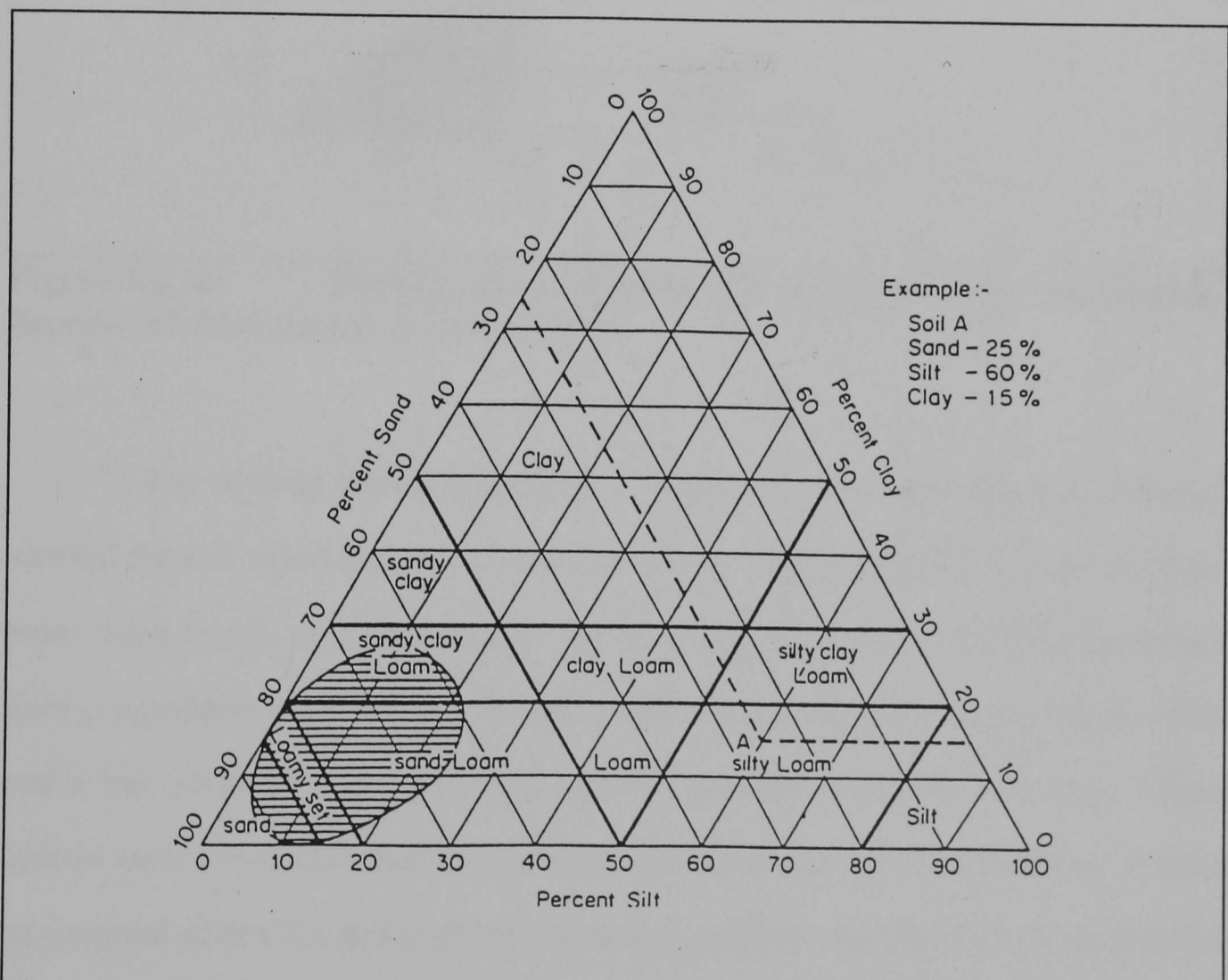

Figure 3.2.2c Triangular chart for particle size classification of soils. Shaded area indicates soils most suitable for stabilisation. Reproduced from Spence & Cook (1983).

Atterburg limit criteria for stabilisation:

Applicable only to the fraction of soil finer than 0.4 mm, roughly
between the limits:

plasticity index	0 - 22 %
liquid limit	7 - 40 %

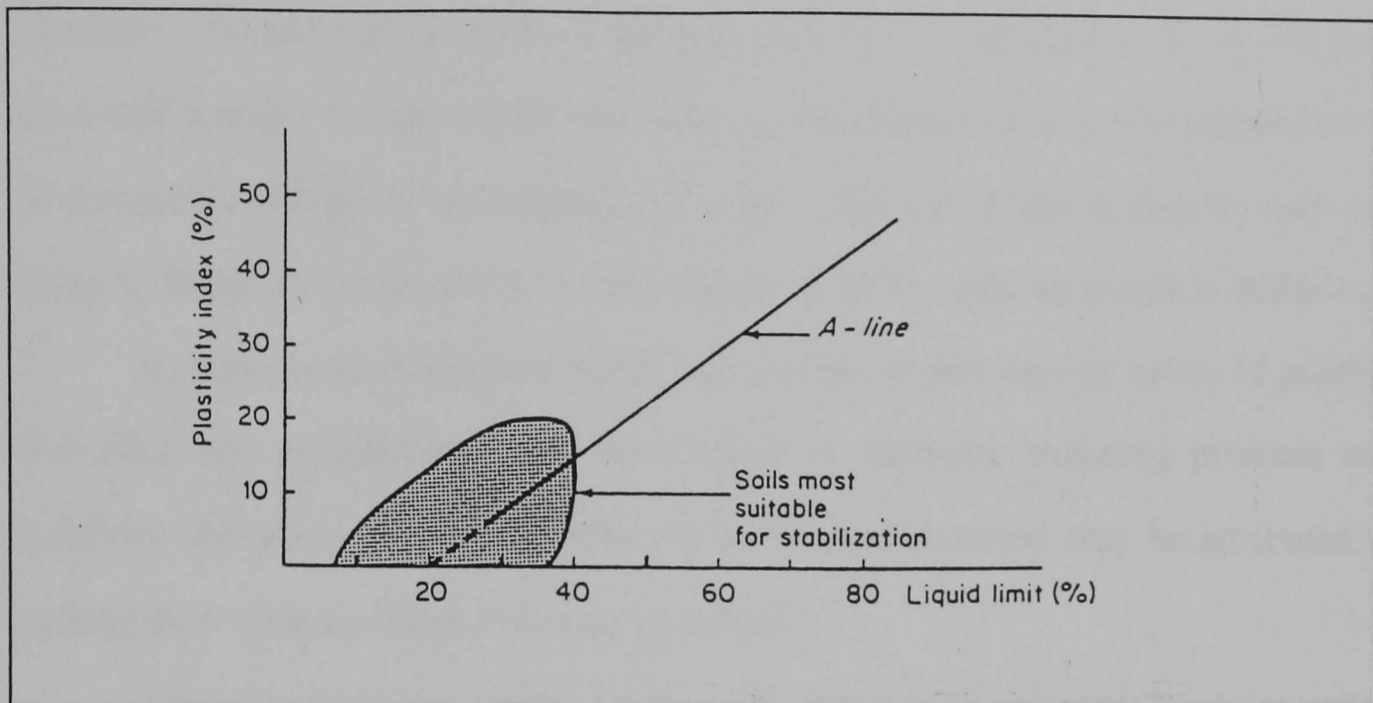

Figure 3.2.2d Plasticity chart showing soils most suitable for stabilisation. Reproduced from Spence & Cook (1983).

It can be seen from the above that there have been a number of criteria put forward for soil selection based on particle size or Atterburg limits or both. In broad terms these criteria are in agreement. A soil suitable for cement stabilisation should have a significant sand content (at least greater than 50%, preferably closer to 75%) and a low plasticity index and clay content (typically less than 25% clay). These criteria are however intended for use as a broad initial guide for soil selection. It must be emphasised that the testing procedure is not complete until the soil or soils selected have been used to produce, cure and test a trial set of blocks. Only after a trial set has proven to be acceptable should the main production run begin.

3.2.3 THE SOIL USED FOR THE EXPERIMENTAL INVESTIGATIONS CONTAINED IN THIS THESIS

As soil is the largest component of soil-cement blocks it was considered essential for experimental repeatability to use a soil which was both well suited to cement stabilisation and readily available with minimal variation in both grading and plasticity. To this end an artificial soil was produced by blending ordinary building sand with kaolin. It may be said that using a manufactured soil is not representative of the soils available in developing countries. However it would also be true that using a Ghanaian soil would not be representative of the soils available in Botswana.

By using a soil which is easily reproducible within narrow limits of grading and plasticity, comparisons between compaction methods, moulding pressure and stabiliser contents may be made and any differences observed may be attributed to variations in method rather than soil variations.

The soil which was used throughout the duration of this work has been called *soil-A*. It was thoroughly tested using both the British Standard methods of test for soils (BS 1377) and the field tests mentioned in appendix B. It is a soil which satisfies the criteria mentioned above. A full description of this soil is given in appendix A.

3.3 TESTS FOR SOILS

3.3.1 TYPES OF TEST

Prior to soil-cement block production there are three main types of test which may be conducted:

- Field tests can divide the soils into broadly suitable and unsuitable categories and if suitable into potential high and low cement classes.

- Laboratory tests can be used to characterise the soils by particle size distribution, plasticity or other numerical measures for relation to the selection criteria (see section 3.2) and enable simple soil modification by blending.
- Trial production tests can be carried out on manufactured blocks to check that the final block properties required (dry strength, wet strength and durability) can be achieved.

Most small-scale manufacturers of blocks, especially those producing blocks at a rural building site, have little or no access to laboratory facilities and in particular to accurate mass measurement to 0.01 g. For these block makers, judicious use of the field tests, the shrinkage test, production trials and past experience has to suffice. The laboratory tests are appropriate where medium or large-scale production is planned, where minimising cement content is especially important or when soil-cement block making is moving into a new area.

The field and laboratory test procedures reported in the literature have been conducted by the author and evaluated using *soil-A*, a carefully characterised soil (of a type suitable for soil-cement block making). For each published test he observed the accuracy of its description, its ease of performance and the accuracy of its results (in terms of internal consistency and agreement with British Standard Tests). A number of the tests examined were found to be misleading and incorrect in parts. The following sections are concerned with highlighting these problematic areas in an attempt to improve testing procedures as a whole.

3.3.2 FIELD TESTS

Field tests are for preliminary site surveying, to identify the soils most likely to be suitable and so restrict the number of soils to be more rigorously assessed by laboratory tests or trial production. The tests (described in appendix B) will provide

a rough idea of a soil's grading and plasticity and also indicate whether a soil contains significant organic matter (reject outright), a predominance of gravel, a predominance of sand or a predominance of fines. They may also be able to distinguish whether silt or clay is the more significant fraction of the fines. They are generally fairly easy to perform and often require little or no experimental equipment, making them very cheap to implement.

However field tests are frequently reported without acknowledging the reliance they place on the operator's senses: although the methods employed are generally simple, the interpretation of the results is a skilled operation. Consider for example the dry strength test. The prepared soil sample is crushed between the fingers and the ease of crushing is taken as a measure of the soil's clay content. For a novice operator the ease of crushing is difficult to assess and as a result so too is the clay content. A skilled operator may compare the ease of crushing with that of soils he/she has previously tested and hence arrive at a more precise conclusion. Tests which rely on personal judgement are open to differing interpretation between operators and depend on the operator's skill for their accuracy. With training and experience these tests may provide a fast, quite accurate determination of the soil's characteristics, however for a novice they can only be expected to provide a more basic picture.

Table 3.3.2 (overleaf) shows which tests are reported by which publication. The glass-jar sedimentation test will be discussed under *laboratory tests* as it contains problems in common with the syphon sedimentation test. The remaining field test methods are generally in agreement and as such no further detailed comments will be made. The test descriptions and notes included in appendix B have been compiled by the author and are a combination of earlier reported methods and the author's own modifications. Each test begins with a brief resumé by the author giving comments on the use to which the test may be put, the accuracy which may be expected from the results, the time taken for completion and the limitations of the test.

All of the test results observed (both the good and the bad), plus the location and depth of the soil samples in question should be recorded in case it is later necessary to use a soil for blending which on preliminary examination had been rejected.

Table 3.3.2 Field tests reported by other authors

TEST NAME	REF.1	Stulz (1983)	Norton (1986)	ILO (1987)	Webb (1988)	U.N. (1964)
SMELL	√	√	√	√	√	x
VISUAL-TOUCH	√	√	x	x	x	√
THREAD	√	√	x	√	ND	x
RIBBON	√	√	√	x	ND	√
SHINE	√	√	√	√	√	√
SEDIMENTATION GLASS-JAR *	x	√	√ a	√ b	√ c	√
DRY STRENGTH	√	√	√	x	x	√
SURFACE WATER	√	√	x	x	√	√

REF No.1 : "Handbook for Building Homes of Earth". Department of Housing and Urban Development, O.I.A, Washington, (undated).

ND : Mentioned but not adequately described.

* : These tests are described in the laboratory test section covering sedimentation test.

a : Ill advised recommendation to add salt, ignores flocculation.

b : Over-concentrated solution causes inaccurate estimation of sand and fines content, salt added ignoring flocculation.

c : Over-concentrated solution, test not intended to discriminate fines into silt and clay.

3.3.3 LABORATORY TESTS

General classification

The laboratory tests establish numerical values for certain soil parameters, primarily the percentage distribution of the different sizes of soil particle present and the plasticity limits. These values are subsequently used to determine the best available soil or combination of soils. All of these tests rely on accurate weighing and/or some form of laboratory equipment. Scales with a resolution higher than one thousandth of the chosen sample weight are desirable. There are four main types of test:

- *sieving tests*
- *sedimentation tests*
- *Atterburg (plasticity) tests*
- *shrinkage tests*

The *sieving tests* separate the different size fractions of the soil into discrete parts thereby indicating the soil's particle grading. The silt and clay fractions are too small to be easily separated by sieving and as such are normally reported as a combined fraction. The larger particles may be separated into a number of size fractions, depending on the number of sieve sizes available, according to the MIT and British Standard particle classification boundaries, given in section 3.1. A full laboratory analysis would give the percentage by weight of each of these size bands.

The *sedimentation tests* if correctly conducted have the ability to separate the larger sand and gravel size fractions from the combined fines fraction and under favourable circumstances to further distinguish the combined fraction into separate silt and clay fractions. However the simplest test, the glass-jar sedimentation test, is usually included under field tests because visual discrimination of the silt/clay boundary may not be possible. In this case the test can only be used to give an idea of the general relative proportions of sand and fines. In its coarsest form the glass-jar sedimentation test provides no more information than a sieving test and although less

accurate, it does not require any mass measurement. Further, although the sedimentation time is long the operator time required to conduct the test is less than that for a sieving test.

The *Atterburg or plasticity tests* define the soil's liquid limit, plastic limit and plasticity. The test methods included are simplified versions of the more rigorous British Standard methods after Norton (1986). The Atterburg limits allow the soil's plasticity characteristics to be related to the criteria given above in section 3.2.

The *shrinkage test* is a test of the soil's contraction on drying and gives a combined measure of the soil's particle grading, plasticity and clay type. It gives an overall idea of the soil's behaviour and suitability for stabilisation. The degree of contraction may be thought of as a measure of the expansive force which the soil stabiliser will have to withstand when a manufactured block is exposed to water. The degree of contraction is then taken as a measure of the quantity of stabiliser required. The shrinkage test may be used as a straight-forward method of determining a soil's suitability for use where more complex testing is not possible or not justified for small-scale production. However it must be remembered that this test gives no direct information on the soil's constituent parts and as such will not allow easy soil modification. It was empirically designed for use with the Cinva Ram, a low-pressure (2 MPa) manual-compaction moulding machine developed by VITA. It was intended to gauge the amount of stabiliser required for a given soil compacted with this machine¹. It is very suitable for small-scale production if soil modification is not considered cost-effective but it must be used in conjunction with tests on trial blocks.

¹. It should be remembered from the above discussion of soil suitability that the compaction pressure used to compact the block does affect the soil requirements. The shrinkage test was empirically calibrated for the Cinva Ram (2 MPa) and is not directly applicable to a machine operating at a different compacting pressure. In general if the machine compacts to a higher pressure then the cement content may be reduced for a given soil shrinkage, or alternatively the range of acceptable soil shrinkage values may be increased.

If the results from these tests are to be useful, a great deal of time and care must be taken. This point is seldom mentioned. These tests appear simple to carry out and they produce numerical values which are relatively easy to interpret, but they are not fool-proof and will produce misleading results if not carefully performed. The sedimentation tests in particular are very delicate, requiring time and practice to perfect. In general soil tests are subject to two accuracy limitations, experimental care and measurement resolution. The following four sections deal with each of the four main test types, giving a simple theoretical background and examining certain misleading and inaccurate aspects contained in earlier reported test methods.

Sieving tests

The sieving tests may be conducted wet or dry, on a complete natural soil sample or on the residue from a syphon sedimentation test. In order to appreciate which of these is the more suitable for any given circumstance a brief consideration of the underlying theory should be given. A sieve test separates the soil fractions by allowing particles with a diameter slightly smaller than the diameter of the sieve holes to pass and retains those which are slightly larger. For an accurate determination of the size fractions present the soil particles must be separate i.e. the soil should be in distinct particles not agglomerations of particles. The ease with which any given soil may be broken up into separate particles determines which method of sieving is appropriate (wet or dry). It should be noted here that dry sieving is only recommended by the British Standards Institute (BS 1377) for clean sands and gravels (i.e. without any significant quantity of cohesive material).

A sieve test conducted on oven-dry soil particles (dried to constant weight at 105-110°C) should be preceded by a breaking-down operation where the particle agglomerations are broken into separate particles. For low cohesion soils, those with only a small clay content, this is quite readily done with a pestle and mortar; however

for soils with a high clay content this may be very difficult. If the soil is not adequately broken down then an over-estimate of the larger sizes and an under-estimate of the combined silt and clay fraction is likely. This is particularly so for lateritic soils which become very hard on drying. In this case a significant quantity of clay-sized particles may remain trapped with the larger sand-sized particles. If on examination it appears that the soil has not been completely broken down then the soil is unsuitable for dry sieving and should be wet sieved or sedimented and subsequently dry sieved (see below).

For wet sieving a measured weight of oven dry soil is soaked in a large quantity of water or preferably water and a suitable dispersing agent. By soaking the soil any particle agglomerations soften and subsequently break up if the resulting suspension is adequately stirred. In order to successfully sieve this soil suspension a large quantity of excess water is required both to wash the particles through the sieves and to separate those particles which loosely adhere to each other as a result of the water's surface tension. Moreover a number of particles slightly smaller than a given sieve's diameter may be retained by water tension across the sieve holes. As a result an improvement in accuracy will be found if the retained samples are dried and resieved.

If the soil is first subject to a syphon sedimentation test, which removes the clay fraction, then a dry sieve test may be conducted on the settled soil residue. This soil residue will be cohesionless, if sedimentation separation has been successful, and therefore very easily broken down into separate particles.

ILO (1987) reports the dry sieve test as a "further soil testing procedure" without any mention of the necessity to break down the lumps of soil which are usually formed on drying and the consequent inaccuracy. The ILO also includes a section on laboratory testing methods which are "briefly discussed". A wet sieve test

is mentioned² but without discussing when or why it should be used in preference to the dry sieve test, indeed the only sieving test method contained in the publication is the under-explained dry sieve method.

Norton (1986) does not report a dry sieve test on soil in a natural condition but rather only a dry sieve test on the residue from a syphon-sedimentation test. This is acceptable providing that the sedimentation test is correctly carried out. However the syphon-sedimentation test as reported by Norton may lead to flocculation (see Sedimentation Tests below) and consequently lead to subsequent further inaccuracy in the dry sieving.

A wet sieve test has also been reported by Norton. He states that "it should be used for analysing lateritic soils in order to ensure that clay particles trapped in fissures on larger particles are washed out". However he does not advocate soaking of the soil to facilitate this but rather to "mix the soil sample with water, and wash it through the sieves". If the soil sample is not soaked before mixing then significant quantities of clay will remain adhered to the larger particles. The wet sieve test relies on water to disperse the soil grains, if sufficient soaking time is not allowed for this dispersion to take place then the test will be subject to the same inaccuracies mentioned above for the dry sieve test.

Norton does not mention that the initial soil sample to be tested should be carefully weighed out nor does he state whether the sample should be oven dried, air dried or damp. Rather he suggests that all of the material remaining on the sieves should be dried out and weighed and that the material carried by the wash water should be collected, dried out and separated with the syphon sedimentation test. In order to sieve such a wet sample a considerable quantity of water is required to wash

². A reference is given to a Road Research Laboratory paper, West & Dumbleton "Wet sieving for the particle size distribution of soils" (Crowthorne, United Kingdom, Road Research Laboratory, 1972).

the particles through, frequently tens of litres (several gallons). To collect and dry such a large quantity of water is both time consuming and impractical without very large collection vessels. If this method is employed for soils containing significant quantities of combined silt and clay then concentration problems will be encountered with the syphon sedimentation test. For example if 1kg of a fine soil containing 40% combined silt and clay fraction is wet sieved either 400g of material will have to be sedimented (four times the recommended concentration) or the dried material will have to be re-wetted, thoroughly mixed (to evenly re-distribute the silt and clay fractions) and subdivided before re-drying to ascertain the new dry weight of the smaller samples.

The wet sieving test, as reported by Norton, will be very time consuming if the wash water is collected and dried. A more sensible method would be to accurately weigh an oven-dried soil sample, soak this in water or preferably water and a dispersing agent and allow the wash water to go uncollected. The weight of the separate dry retained materials may then be related to the original dry sample weight to give the percentage of each size fraction and the combined silt and clay fraction may be assumed to be the difference between the original total dry sample weight and the sum of the dry fraction weights. The clay content may be determined by a separate syphon sedimentation test and the silt fraction assumed to be the difference between the original sample weight and the combined sand, gravel and clay fractions.

Sedimentation tests

The sedimentation tests are based upon Stoke's law of sedimentation which predicts the velocity in free fall of any diameter spherical particle of known specific gravity in a fluid of known viscosity at low concentration. For sedimentation testing it is assumed that the specific gravity is the same for each soil particle, each particle is approximately spherical and each soil grain exists as a separate particle. Hence the

rate of fall is dependant only on the diameter of the particle. Larger diameter particles will fall more quickly than smaller diameter ones and hence the settled material will be graded with large particles at the bottom and fine particles at the top. One problem which may be thought of with this method of separation concerns the distances that particles have to fall. A small particle initially close to the bottom of the vessel falling slowly may settle in the same time as a large particle initially at the top of the vessel, leading to contamination. This does occur, but as the velocity of fall is proportional to the square of the particle diameter larger particles fall significantly faster than small ones and the contamination is only minor.

At high concentrations the particles interfere with each other, leading to "wipe-down" whereby small particles are carried down by larger ones. Similarly if the soil sample is not sufficiently dispersed agglomerations of particles will fall more quickly than would be the case for separate particles. Particle agglomeration may occur as a result of two separate factors; firstly, as the result of insufficient soaking whereby particles, primarily clay and silt, remain bound together or bound to larger sand particles and secondly when the silt and clay particles, initially dispersed, reassociate as a result of electrostatic interaction to form flocs (flocculation). In either case settlement will be affected and the measured fractions incorrect.

The glass-jar sedimentation test uses the differential settlement phenomena to give an idea of the relative proportions of different sized particles. A suspension of soil is allowed to settle undisturbed in a parallel-sided vessel. As a result of the differential settling and a usually slightly discontinuous range of particle sizes, the material forms settled layers of gravel, sand, silt and clay. The height of each different soil layer formed is measured relative to the total settled height and taken to be the relative proportions of each discernable size fraction. The formation of layers is readily visible in light coloured soils which do not contain a perfectly continuous range of particle sizes but for other soils the layers may be less visible. For most

soils it is possible to determine the boundary between the sand and silt layers as sand grains may be individually discriminated while silt grains appear as a homogenous mass. However it is frequently difficult to see the boundary between silt and clay as both materials' grains are too small to be discerned. More complex timed methods have been put forward to attempt to overcome this discrimination problem but there are also problems with these (see below).

The syphon sedimentation test also uses the differential settlement phenomena. Rather than attempting to use the settled layers as indicators of the sample's different size fractions it attempts to separate the clay fraction by allowing heavier soil fractions to settle out of a suspension so that the remaining fluid, containing the clay particles, can be dried separately. If the initial dry soil mass is known then the percentage of clay may be found. This test depends on the clay remaining in suspension longer than any other heavier soil component and as such relies on the initial suspension being dilute and effectively dispersed. If "wipe-down" or agglomeration occur then the material syphoned off in suspension will be less than the true clay fraction. Moreover if flocculation occurs it is frequently not possible to discern the level of the settled material and hence the correct level for the separation disk. The flocs, containing both silt and clay particles, interfere with each other and slowly settle en masse in a loosely packed arrangement rather than as discrete particles. In this condition silt does not settle significantly faster than clay and hence cannot be distinguished. The formation of a flocculated suspension is usually readily apparent as a pronounced clear layer of water will form quite rapidly above the remaining suspended material during settlement. If the syphon sedimentation test is to be used the soil suspension must be both fully dispersed and deflocculated, a point frequently neglected by the literature.

The "sedimentation bottle test" (glass-jar sedimentation test) of ILO (1987), reports that "the bottle is first filled to one third with clean, uncontaminated water. Approximately the same volume of dry soil (which has passed through the 6 mm

sieve) and a teaspoon full of common salt are added. Salt facilitates the dispersion of soil particles". Using equal volumes of dry soil and water will give a highly concentrated suspension of soil and lead to significant wipe-down of the fine fraction (see above). The diagram included with this description actually worsens this situation with mistaken captions. Diagram 1 shows "1. Bottle one third filled with water." diagram 2 then shows a full bottle with a one third volume of water resting on a two thirds volume of soil stating "2. Add one teaspoon full of salt and fill bottle with soil". Filling a bottle containing one third of water with dry soil will produce an intensely concentrated suspension.

Having shaken the soil bottle it is stated that "Two or three minutes later the water will start clearing....Two or three distinct layers will be observed, with the lowest layer containing fine gravel, the central layer containing the sand fraction and the top layer containing the combined silt and clay fraction....The individual percentages can be determined by direct measurement of the depth of each layer". This is most misleading. The above implies direct measurement of the layer height after only two to three minutes. Only the sand-sized fraction would have settled in this short time, silt and clay particles fall much more slowly (clay falling at approximately twelve millimetres per hour) and would still be in suspension. Moreover unless the soil were to be predominantly clean gravel and sand, a high concentration of fines would be present which would not enable "distinct layers" to be seen, rather the entire depth would appear muddy. This sedimentation bottle test has failed to produce any distinct layers when performed by the author on a known well graded soil containing 76 % sand, 15 % clay and 9 % silt. The solution was too concentrated, the whole appearing as thick flocculated liquid. The relative volume of soil to water should be reduced to at least one quarter to three quarters.

Furthermore, Grimshaw (1971) has reported that salt is a clay flocculant causing these particles to agglomerate into larger flocs, not to disperse as mentioned

above. The addition of salt has been put forward, by Webb (1988) reporting that "salt will speed up the final settlement of particles". This is correct as the flocs formed are larger and heavier than individual clay particles and hence fall more quickly. However Webb puts forward this glass-jar type sedimentation test with salt to quickly and roughly determine the relative sand and fines content. It must be remembered that the fines are not separated into silt and clay fractions and may not be distinguished when flocculation occurs (see above). More suitable dispersants which do not cause flocculation are listed in appendix C.

Norton (1986) suggests a "Simple particle separation by sedimentation" test which uses a timed observation system rather than visually discriminating settled layers. This test advises that a jar should be one third filled with slightly compacted dry soil and this height (h), measured from the base of the jar, be recorded. Water and a pinch of salt is then added to fill the jar to three quarters full. The jar is shaken, soaked for one hour and re-shaken. After the final shaking the jar is left to stand and a stopwatch is started. "When one minute is up, mark on the side of the jar....This amount (T1) is fine gravel and sand....After 30 minutes mark again....(T2) is fine gravel, sand and silt together. After 24 hours mark again....(T3) includes fine gravel, sand, silt and clay. The depth of clay = $T3-T2$. The depth of silt = $T2-T1$. Divide each depth by the total (h)...." and so gain the percentage proportion of each particle size. As has been mentioned earlier, a dry soil will expand on wetting. If the settled heights are related to the initial compacted height of the soil as described, then in general the sum of the soil fractions will exceed 100 %. A more satisfactory solution is to relate the measured heights to the total settled soil height of the soil after twenty four hours. Again it is recommended that "a pinch of salt" should be added. This is not correct, in this test Norton is proposing to separate the silt and clay fraction and has apparently ignored the flocculating effect of salt. If flocculation occurs the level of the fully settled material will be obscured by the semi-settled

flocculated layer. If the top of the flocculated layer is taken to be the settled height nonsensical results will follow as the settled height apparently reduces as the floc settles. Again flocculation will be apparent as a marked clear layer quickly appearing above the remaining suspended material. If flocculation occurs the suspension must be deflocculated.

Soil flocculation may occur without the addition of salt (chlorinated water among other things may have this effect), if it does then the suspension must be treated with one of the compounds listed in appendix C to deflocculate and redisperse it.

Atterburg tests

The Atterburg or plasticity tests define the moisture content at which the soil passes from a liquid state to plastic state and from a plastic state to a solid state; these boundary points are the liquid and plastic limits respectively. The transition from liquid to plastic to solid is a gradual process, viscosity and shear resistance increase as the water content decreases. The precise boundaries between the states are defined by the tests themselves and not as a result of theoretical analysis or an intrinsic soil property, e.g. the plastic limit of a soil is the moisture content at which a thread of soil with particles greater than 0.425mm removed will break when rolled down to 3mm. Because of this reliance on the testing method different test procedures and even different test operators will give varying results. It is therefore most important that care is taken to follow the method given and to have the tests conducted by the same operator. The most important piece of equipment for the plasticity tests given in appendix C is the hand of the operator.

The plastic limit test described in appendix C is that used by the British Standards Institute (BS1377). The liquid limit test reported is a simplified version of the Casagrande liquid limit test. The full Casagrande test requires the use of a piece

of specialised equipment which mechanically taps the curved dish by vertically dropping it a set distance at a set rate. In the simplified version of the test the curved dish is tapped horizontally by the operator's hand. The simplified test given was first reported in "Handbook for Building Homes of Earth" (O.I.A, undated) and subsequently repeated unaltered by Norton (1986) and Stulz (1983). It should be remembered when using this variant of the test that it is likely to give more variable results than the original. The force which is used to manually tap the curved dish depends on the operator, so it is desirable that the same operator conducts each test if comparisons are to be valid.

Other authors either describe very similar tests to those given in appendix C or refer the reader to the British Standard tests (BS1377). Concerning those tests which they describe two points need to be mentioned. Firstly sample preparation may be incompletely specified, it is not always clear that the soil sample to be tested must have all particles larger than 0.425 mm removed prior to testing for both the liquid and plastic limit tests. Secondly, the soil mixing operations should be very thorough. The soil should be mixed for at least 10 minutes (up to 30 or 40 minutes for heavy clays). Mixing should continue for several minutes even after the disappearance of any wet or dry spots. For the liquid limit test it is not sufficient to add and mix soil or water to the sample while it is still in the curved dish. The sample should first be removed from the dish to allow mixing in a larger, more suitable container.

Stulz (1983) suggests that "If you already know that you are going to add a stabiliser to your soil, then add the same proportion of stabiliser to your sample as you intend to use in your house". This is misleading as the term stabiliser is normally used to include cementitious compounds; cement, lime and pozzolanas etc. I believe that by "stabiliser" Stulz is referring to soil modifiers i.e. sand and clay rather than stabilisers. The modified soil should be tested but without the addition of cementitious stabilisers which will dramatically change the plasticity of the soil. In

the case of cement the hydration reaction begins immediately the cement contacts water and initially progresses quickly. As a result the plasticity of the soil will change quickly with time and not allow any meaningful results to be obtained.

Shrinkage test

There are a large number of shrinkage-type tests which have been reported. The test which will be discussed here is a linear shrinkage test conducted on natural soil which has had particles larger than 6mm removed. This test has been included as a laboratory test because it requires a large mould and up to seven days of drying. The shrinkage test gives an idea of the gross behaviour of the soil on drying. The change in length of the soil sample may be considered to represent the expansion force which the soil stabiliser will have to resist when the final block becomes wet. In general the smaller the soil's contraction on drying the smaller the quantity of stabiliser required.

This test has been reported with two different but broadly similar experimental techniques. The method included here requires the soil mix to be at or near its liquid limit, while the other method frequently reported requires the soil to be at its optimum moisture content for maximum density moulding. The near-liquid-limit method has been chosen as this mixture of soil will contain more water and hence give slightly higher shrinkage values. The greater variation in liquid limit moisture content (between soils) compared to the more similar optimum moisture content will give a broader range of shrinkage values for different soils and hence will allow better discrimination. Again the recommended cement addition given by this test are only a guide and must be verified with trial block production.

The test has been calibrated by VITA for use with the Cinva Ram compacting machine (details are given with the test in appendix C) but not for other machines. Webb (1988) has suggested a very similar set of values for the Brepack machine

which operates at five times the compaction pressure of the Cinva Ram, however it appears that the two sets of data are not comparable as the set given for the Brepack will produce blocks to a higher strength standard than that for the Cinva Ram. The cement saving appears small unless blocks of the same strength are compared. For instance, Webb cites blocks produced in Kenya from "Murram soil containing about 16 per cent clay stabilised with 4 per cent cement by weight under a compaction pressure of 10 MPa" and states that these "compared favourably with blocks made on a block press machine which used 18 per cent cement as a stabiliser. In this case the compacting pressure was 2 MPa". In this case the 18 % cement content used with low-pressure compaction was apparently equivalent to a 4 % content at high-pressure compaction. This is an extreme example but does illustrate the trend which is not apparent from the table included with the shrinkage test in appendix C.

One final point to mention with respect to the cement content table from Webb is that for shrinkages of less than 15mm (in 600 mm) the soil should not be automatically rejected. It is not clear why Webb has chosen to reject this class of shrinkage. If the soil does have some plasticity, sufficient to allow adequate green strength for demoulding, then a low shrinkage soil should produce admirable blocks when compacted to high pressure. Lower shrinkage on drying will reflect the soil's potential to produce blocks which will be less prone to expansion on wetting and hence more durable. It is the requirement for green strength on demoulding which governs the minimum cohesion and hence shrinkage value. It would be expected that a high pressure machine should be able to handle soils with lower shrinkage than would a low pressure machine; from the VITA table the reverse would appear to be the case. A better guide would be that at either pressure soils with shrinkage down to a nominal value of 5mm should be investigated but zero shrinkage materials (0 - 5 mm) should be rejected.

This test is most useful where the scale of production does not justify the use of more elaborate tests or where it has been initially decided that soil modification will not be used. It does not give useful information for predictive soil modification but may be used to check the effectiveness of soil modification by trial.

3.4 COHERENT SOIL TESTING PLANS

3.4.1 INTRODUCTION

In general the literature concerned with soil testing provides a number of suitable tests but does not provide a logical testing plan for their implementation. The following section discusses the soil-testing needs for differing project sizes and purposes. From this discussion it is hoped that the reader may be able to appreciate the need for different scales of soil testing. The large variation in scale of production, climatic conditions and use to which the final structure is put does not lend itself to specific recommendation, however certain generalisations are possible and would appear helpful as these are usually lacking elsewhere. The section is completed with an example of a coherent testing plan, comprising a testing tree for the field tests and a set of coherent laboratory tests, suitable for a medium-scale producer.

In general there are two paths which may be followed by a soil-cement block producer, to use the available soil in its natural state or to use a modified soil (one produced by the combination of two less suitable soils). The decision whether to modify the natural soil is a complicated one. If the available soils are quite unsuitable for block production then either the soil must be modified or an alternative site must be found. Often however, although the available soil is acceptable for production in its natural condition, if it is modified blocks may be produced which are cheaper or of better quality. The former is achieved by maintaining the cement content while improving the soil hence increasing block strength, the latter by maintaining the

strength while reducing the cement content. The difference in cost or block properties resulting from modification depends on the degree of improvement which would be possible. The further away from the "ideal" soil the natural soil lies then the greater the improvement possible and hence the greater the justification for modification.

In small-scale block production, for example for a single building (self-built unit), the savings made through soil modification of an acceptable soil³ are likely to be small. In this case the additional cost in terms of time and equipment required to perform all of the laboratory soil tests may not be justified. If the soil appears suitable from the field tests and the simple shrinkage box test, it would generally be more appropriate to use the natural soil, increasing the cement content if greater wet strength is required. If none of the available soils are suitable then modification will be necessary or an alternative building material should be found. Modification may be done by trial and error, checking the results with the simple shrinkage box test. This will then not require the grading or plasticity to be known but will take a significant time to perform adequately (the shrinkage test may take up to 12 days to complete). If the equipment is available it will always be beneficial to conduct the laboratory tests but adequate blocks may be produced without. The most fundamental piece of equipment required for laboratory testing is an accurate weighing balance, ideally capable of weighing to one thousandth of the sample weight.

In medium-scale block production, for example local village/community building programmes, the economies resulting from modification may be more significant and hence justify the increased testing costs resulting from a more complete laboratory testing program. Such a programme would include the determination of the soil's grading and plasticity characteristics. A more complete testing program enables

³. "acceptable soil" here means one which may be stabilised without modification (even if quality improvement is possible through modification) as opposed to an unacceptable soil which will not allow adequate stabilisation unless it is modified.

faster more reliable modification processes to be used. The soil may be predictively modified to meet the criteria mentioned earlier in section 3.2, rather than imprecise modification by trial and error. The choice between modifying or not modifying should be based on the relative cost of the cement to that of the labour or machinery required to perform the additional soil blending operation. If the relative cost of cement is high and significant cement saving is possible through modification, then in general it will be economically beneficial to modify such a soil to minimise its cement content. However if labour costs are high then it may be preferable to accept a high cement content and not modify the soil. Each case should be judged on its own merits.

For large-scale block production, involving considerable capital expenditure, then a full laboratory analysis including soil grading, plasticity and chemical composition may be justified. This type of test programme is not feasible without a well equipped, dedicated soil testing laboratory. (These are usually available through the government department dealing with road building). In this case several soil samples considered suitable from the field test selection process would be sent away to a soil laboratory to be tested, either so that the best can be identified or so that an optimum soil-blending formula can be devised. Even after full laboratory soil testing, trial block production testing must be carried out with the modified soil and local on-site laboratory testing is desirable to monitor the soil used throughout the project.

The above argument assumes that the final properties required of the soil-cement blocks are known. This is frequently not the case and deserves a brief consideration. Numerous standards have been developed for fired clay products and concrete blocks, especially in the developed world. However building material standards are much less advanced in Developing Countries and in the case of soil-cement blocks frequently non-existent. One draft specification for stabilised-soil building blocks backed by the United Nations Commission for Human Settlements

(UNCHS) in Nairobi, Kenya 1990, was based on a report presented by the Building Research Establishment (Webb 1991). This specification requires that water absorption after 24 hours of soaking should not exceed 15% of the original mass and that the minimum unconfined wet compressive strength after 24 hours immersion should not be less than 1.5 MPa (N/mm²). This specification may be used as an initial base standard for simple single storey buildings constructed with soil-cement blocks in arid or semi-arid regions. However it might be as well to remember that, provided enough strength is present to allow the wall to be self-supporting, durability is the factor which governs the building's life. A wet strength of 1.5 MPa should be sufficient to prevent building collapse⁴ but might be inadequate for reasonable durability in less arid regions. The field of building standards relating to stabilised-soil building blocks is one which requires a large amount of further work. The wide variation in climatic conditions throughout the world necessitates regional or national building standards rather than global ones. At present these standards do not exist and a degree of judgement must be used when deciding the final block properties required. It would seem that the above specification can be taken as the minimum acceptable standard but that for areas with high rainfall the wet strength requirement should be increased to 2.8 MPa or an external render applied to the wall. In such conditions any economic analysis carried out to assess the viability of soil modification should include due consideration of the cost of this external render or lack of it.

It may now be seen that the soil testing programme should be tailored to the scale of the project and the available testing equipment or testing funds. Soil testing is a supplement to reduce the number of trial blocks which need to be produced. A thorough testing plan should identify soils which are likely to be suitable and disqualify the unsuitable ones. All the above scales of production should utilise the

⁴ A wall of blocks with this strength could be built about 65 m high before the bottom courses started to crush.

basic field tests to reduce the number of soils to be subsequently considered. The simple laboratory tests will then further simplify the selection and modification of the soil. Full-scale laboratory testing will provide more accurate values for the grading and plasticity of the tested soils, although this accuracy improvement should be very minor if the simple laboratory tests are carried out correctly. Full-scale testing will also provide information on the chemical composition of the soil. The chemical composition may reveal the presence of soluble salts, primarily sulphates, which can attack the hardened cement's calcium silicate hydrate matrix and possibly lead to a reduction in strength with time. This reduction in strength with time may take several years to become apparent and therefore cannot be tested practically by trial block production.

The following sections show how the soil tests given in appendices B and C may be used to provide a coherent soil test plan without undue duplication. Not every test mentioned in the appendices need be conducted in every case; a number of the tests are alternatives which may be used according to the equipment available or can be used as cross checks if required.

3.4.2 PRELIMINARY ON-SITE SOIL TESTING PLAN

The initial field tests should be conducted on-site to assess the gross suitability of the available soils, arranging them into one of the categories listed below. Fines in this categorisation refers to the combined silt and clay content but it should be noted that a soil containing clay-free fines regardless of the quantity of fines should be reported as very low clay and considered unsuitable.

- *Organic* *Unsuitable. REJECT*
- *Very low clay* *Unsuitable unless clay added*
- *Very low/zero fines* *Unsuitable unless clay/silt added*
- *Low fines* *Suitable, low cement content likely*
- *High fines* *Suitable, high cement content likely*
- *Very high fines* *Unsuitable unless sand added*

TEST NAME

OBSERVATIONS RECORDED

- Smell** If musty smell is present record as organic and reject soil as unsuitable. If no smell, proceed.
- Visual-touch** To determine relative coarse/fine fraction present. If no fines are present record as *unsuitable, no fines*. If no sand/gravel present record as *unsuitable, very high fines* (proceed to shine and bite test to determine if fines are predominantly silt or clay for future reference). If a mixture of coarse and fine present, proceed.
- Thread** To identify high plastic clay content and non-plastic soils. If a high plastic clay content is present record as *unsuitable, very high fines*. If it is not possible to form a thread then non-plastic, record as *unsuitable, very low fines*. If neither, proceed. (The ribbon test may be used as an alternative or for verification).
- Shine** To tentatively determine whether a combination soil is high or low fines. If predominantly sandy record as *suitable, low fines*. If predominantly silty or clayey record as *suitable, high fines*. Proceed with sedimentation test (use one third of a jar of soil if predominantly sandy and one quarter to one sixth if predominantly fines).

Sedimentation To give a rough analysis of relative sand/silt/clay composition. (Here the fines content may be further described by recording the separate percentages of silt and clay not previously included in the above categorisation plan.) Less than 50 % sand/gravel record *unsuitable, very high fines*. 50 - 70 % sand record as *suitable, high fines*. 70 - 80 % sand record as *suitable, low fines*. Greater than 80 % sand record as *unsuitable very low fines* (these are arbitrary boundaries and intended as a guide only). If no clay is present record as *unsuitable, very low clay*.

Dry strength and wet-shaking These are additional tests on the fine soil fraction (< 0.425 mm.) and provide information on the clay content of the fines. These tests should be carried out if the glass-jar sedimentation test fails to discriminate silt from clay. If these tests show that no clay is present in the fines then the soil should be reported as *unsuitable, very low clay*.

Soils which are considered suitable from the on-site testing plan may then be more closely examined with the simple shrinkage box test and/or the following simple laboratory tests (dependant on the equipment and funds available). Such further testing will determine which soil is likely to produce the most acceptable blocks, remembering the points mentioned above in the consideration of suitable soils, section 3.2.

3.4.3 FIELD TESTING TREE TO ILLUSTRATE A COHERENT SOIL-TESTING PLAN

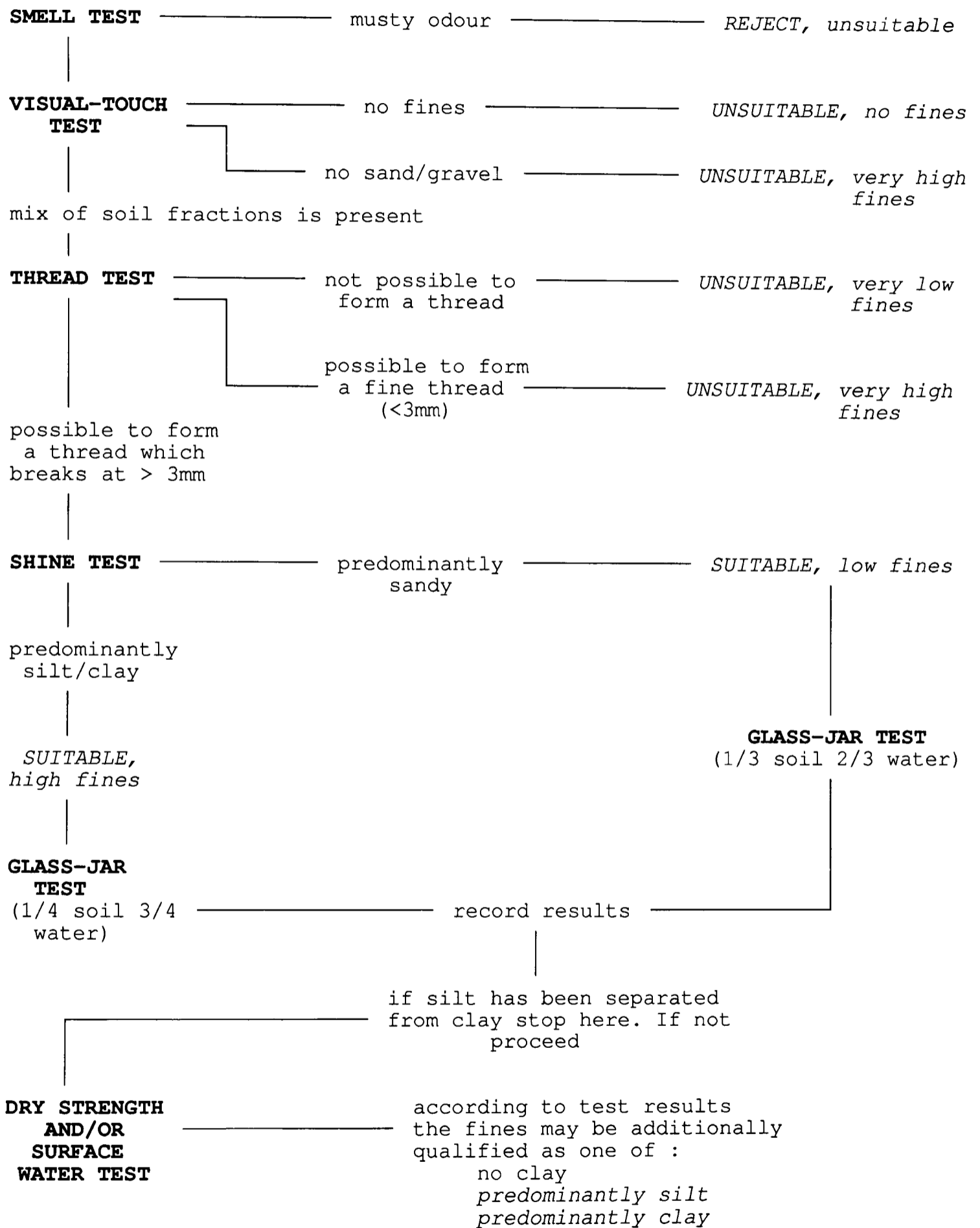

This field testing tree diagram illustrates one sequence in which the field tests may be carried out. This diagram does not include every possible field test but should illustrate that basic soil selection is possible if the tests are used coherently in a logical order.

3.4.4 LABORATORY TESTING PLANS

Laboratory tests will provide more precise detailed information on the soil's grading and plasticity. This information should be used to select the soil most likely to produce acceptable blocks based on the selection criteria given in section 3.2. Laboratory test analysis for soils considered suitable on the basis of the above preliminary tests may be conducted using one of the following plans. Which plan is used depends on the resources available, Plan 1 requires accurate weighing equipment as the soil samples used for sedimentation and dry sieving are small. Plan 2 requires a moderately large supply of water for effective wet sieving. Plan 3 relies on representative soil samples being used. Other plans are of course possible.

If no single soil seems suitable or only barely suitable then a combination of two (or more, if justified) soils may frequently produce a more successful material. For example a soil without fines may be improved (modified) by adding a suitable quantity of a clayey soil containing a high fines content. The grading information gained from the laboratory tests will enable the relative amounts of each soil type required to be provisionally calculated. Although the modified soil should be re-tested using the laboratory tests the modification process will be greatly simplified.

PLAN 1.

Sedimentation test (syphon);

Used to measure the clay fraction of the soil. The settled material may be subsequently dried and used in the dry sieve test.

Dry sieve test;

The settled material from above may be sieved dry to determine the gravel, sand and silt fractions.

Atterburg tests;

Should be conducted using the original soil, suitably sieved, to determine the liquid/plastic limits and plasticity index.

PLAN 2.

Wet sieve test;

Used to determine the gravel and sand (fines retained) fraction of the soil and to separate the silt/clay fraction for sedimentation.

Sedimentation test (syphon);

The material passing the 0.063 mm wet sieve may be separated into silt and clay fractions.

Atterburg tests;

As above.

PLAN 3.

Wet sieve test;

Used to determine the gravel and sand (fines discarded) fractions of the soil.

Sedimentation test (syphon);

A separate portion of the above sample is sedimented to determine the clay fraction. The silt fraction is found by adding the total measured soil percentages and taking this figure away from 100 %.

Atterburg tests;

As above.

Part B:
SLOW COMPACTION

CHAPTER 4

QUASI-STATIC COMPACTION OF SOIL-CEMENT BLOCKS

4.1 INTRODUCTION TO QUASI-STATIC COMPACTION

Quasi-static or slowly applied compaction is the process used by the majority of soil-block making machines. The loose soil is compressed by slowly applying a large force to a piston which moves into a parallel-sided mould. The magnitude of the pressure which is applied varies from machine to machine but is generally within the range of 1-10 MPa. The Cinva Ram is a well known low-pressure machine which uses force applied manually through a lever mechanism to produce a compaction pressure of up to 2 MPa. The Brepack is an example of a high-pressure machine which applies between 8 and 10 MPa compaction. The Brepack uses a lever mechanism for the initial compaction and finishes with a manually operated hydraulic ram.

If a standard block's dimensions are assumed to be 290x140x100 mm (standard-size) and that pressure application is to the largest block face then compaction pressures of 2 and 10 MPa equate to static loads of 8.3 and 41.4 metric tonnes. These are appreciable loadings for the structure of any machine to withstand. As has been discussed in chapter 1 (section 1.2.3) the quasi-static compaction method appears to have been followed as a result of the early use of simple Cinva Ram type machines. There has been very little research conducted to assess the effectiveness

of this method of compaction compared to the alternative dynamic methods. The compaction pressure exerted by quasi-static block forming machines has been measured by Webb (1988) among others by placing a load cell inside the mould box. Different sized packing pieces were used to change the effective bridging span of the load cell until maximum force was recorded. This method of measurement only indicates the maximum force applied to the surface of the block nearest to the moving mould-piston. No investigation appears to have been carried out to measure the force transmitted through the soil during compaction and hence the compaction pressure experienced by regions of the block further away from the moving piston is unknown. Lunt (1980) has shown that for a given quantity of stabiliser increasing the compaction pressure will result in stronger cured blocks. This increase in cured strength must be a result of improved densification of the soil. If it were possible to improve the internal pressure transmission by reducing mould-wall friction, tapering the mould, using pressure cycling or double sided compaction, then the strength benefit of increased density would become available without requiring higher compaction pressures (Lunt recommends compaction pressures in the range 8-16 MPa).

No report of any investigation into the internal condition of the soil during compaction has been found. As a result the internal state of the soil is not known and any discussion of the potential effects of varying the above mentioned moulding parameters is speculative. At the outset of this research a number of simple models were postulated to describe the condition of the soil during compaction. These are described below in section 4.2. Each model has different implications for the moulding parameters mentioned above. For example if the soil attains a pseudo-hydrostatic condition then double-sided compaction would have no effect as the transmission of pressure is already perfect. Indeed if a pseudo-hydrostatic condition was found, equivalent compaction pressures could be generated by applying the

moulding force to one of the smaller blocks faces. Conversely if friction with the mould wall is significant then moulding force applied to one of the smaller block faces will result in significantly reduced compaction in the regions of the block furthest from the moving piston. In this case double-sided compaction would be a considerable advantage, effectively halving the mould wall area available for frictional shear.

The following chapter describes the research carried out to investigate the internal state of the soil during compaction and the manner in which the applied pressure is transmitted through the block. It utilises direct measurement of mould wall and mould base pressures during compaction to assess whether varying the moulding parameters would produce a significant increase in the mean density or the minimum density within the block.

The experimental method and instrumentation details are included in appendices D and E respectively. *Soil-A* was used for all of the blocks produced and in each case the optimum water content of 8% was used.

4.2 MODELS TO DESCRIBE THE INTERNAL COMPACTION MECHANISM FOR COMPRESSED BLOCKS PRODUCED BY QUASI-STATIC COMPRESSION

A number of simple models were initially postulated to describe the internal compaction mechanism; a *Simple Hydrostatic Fluid Model*, a *Pipe Flow Model*, a *Solid Model* (based on Poisson's Ratio), a *Frictional Poisson Flow Model* (based on a combination of Poisson's Ratio and frictional flow) and an *Effective-Pressure Model*. The models which are presented are intended to provide *simple* working models at a most basic level. They do not attempt to provide a precise mathematical model of the

soil behaviour, any such mathematical model would be inherently dependent on the assigned values for the soil parameters. A finite element analysis was not conducted as the properties of the soil vary greatly during compaction and may not be easily predicted as they depend not only on the current state of the soil but also its past history. In chapter eight a finite element analysis has been conducted specifically to investigate the build-up of a compression wave front under dynamic compaction. No such phenomena was expected in quasi-static compaction and hence finite element analysis was not considered to be justified in this case.

4.2.1 SIMPLE HYDROSTATIC FLUID MODEL

The simplest model which might be used to describe the compaction process is the Hydrostatic Fluid Model. This assumes that the soil behaves like a contained fluid, namely that the pressure within the soil is the same in all lateral directions and increases in a downward vertical direction only as a result of the overburden pressure (weight of soil above the layer in question). This overburden pressure is insignificant compared to the external pressures applied to a block during moulding.

This model predicts that if a compaction pressure of 10 MPa is applied to the top surface of the mould, both the mould-walls and the base of the mould should also experience a transmitted pressure of 10 MPa. It requires that there is no shear force between the soil and the mould-walls. If this model were to prove correct then the moulding force may be applied to the smallest block face without affecting the final density of the block. The force required to produce a compaction pressure of 2 and 10 MPa could then be reduced to 2.8 and 14 metric tonnes respectively.

4.2.2 PIPE FLOW MODEL

This model assumes that the soil is behaving like a viscous compressible fluid flowing through a pipe. A viscous fluid may support a shear force while it is flowing.

The more viscous the fluid, the longer it will take to flow and the larger the shear force it can maintain. An applied axial force will result in acceleration which will cause velocity. This velocity will result in the generation of shear forces, the magnitude of which depend on the viscosity of the soil. These shear forces will reduce the axial force reaching lower layers while the soil is moving and hence reduce the lateral pressure there. After a time the velocity results in displacement causing compression. This builds up pressure which then opposes the applied top force, reducing first the acceleration and subsequently the velocity. According to fluid theory, when the velocity of flow reduces to zero, hydrostatic conditions should again prevail as a stationary fluid cannot support a shear force. In which case there should be no difference between conventional and smallest face compaction at the end of compression.

By applying the moulding force to the smallest face the load required to produce a given pressure is greatly reduced however the mould-wall area available for shear is increased. If the fluid flow concept of "hydraulic radius" is adapted for this situation to mean mould wall circumference divided by the surface area over which the moulding force is applied, then for conventional orientation of a standard-size block this is 21.2 cm, rising to 34.3cm for smallest face compaction. This indicates that the time taken for the soil to "flow" may be significantly increased by smallest face compaction even though the final compression remains the same (see figure 4.2.2). Thus this model predicts that smallest face compaction should be as effective as conventional orientation but that the maximum applied force would have to be sustained for longer, thereby reducing the block production rate.

As the flow of soil may be expected to have stopped when the compacting piston ceases to move, this zero soil flow should result in equalised hydrostatic conditions and the mould wall pressure equalising to a simple hydrostatic condition. If the mould wall pressure does not equalise then either the soil has become so

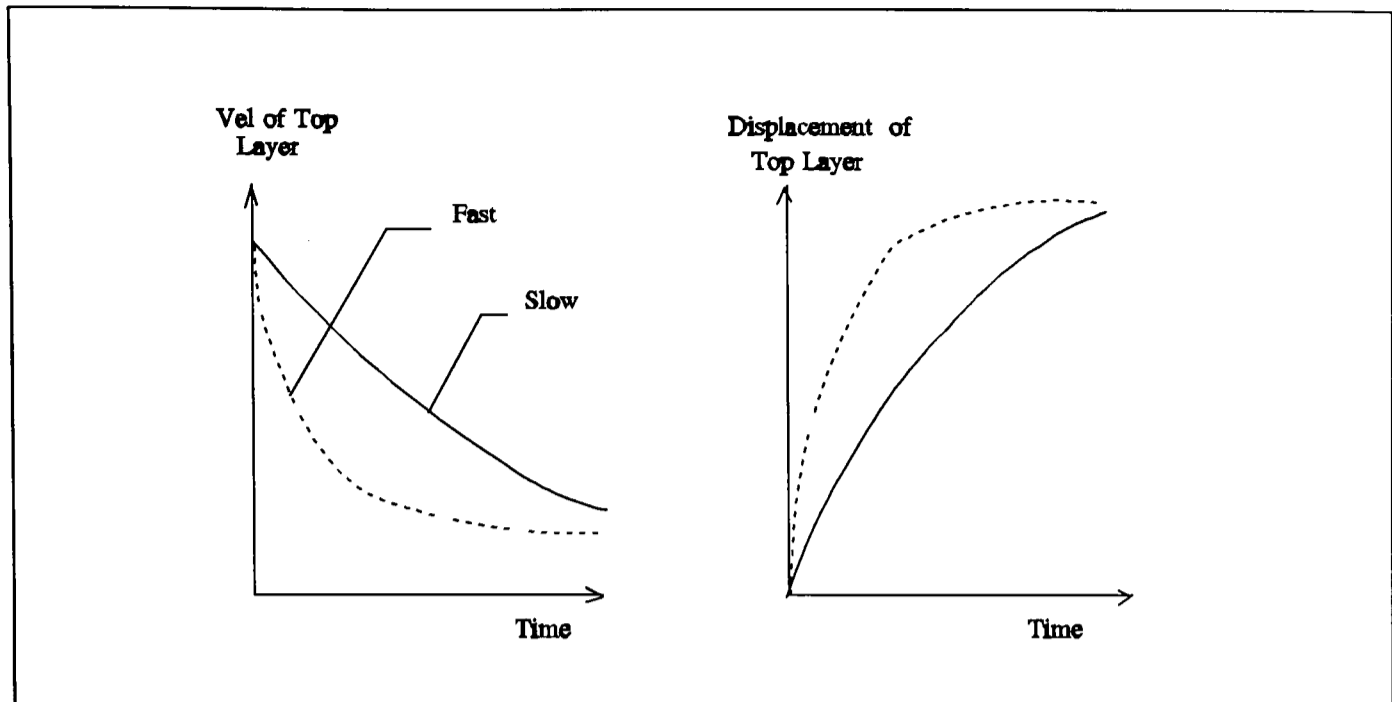

Figure 4.2.2 The rate of change of top layer velocity and displacement with time for pipe-flow behaviour.

viscous that its rate of flow is too slow to show this equalisation in the time available (typically 30 seconds for block production) or the soil may no longer be described as a fluid by the end of compaction, resisting shear forces by behaving as a solid.

Shear forces with the mould wall play an important part in this model. If the shear forces generated by soil friction with the mould walls dominate, as suggested by this model, then an improvement in compaction achieved within a given short time will result from reducing the mould wall friction coefficient.

4.2.3 SOLID POISSON MODEL (POISSON'S RATIO)

By applying a pressure to the top surface of a solid object, vertical compressive strain is induced in the medium. This results in a lateral tensile strain. The ratio of lateral tensile strain to vertical compressive strain is defined as the Poisson's Ratio of the medium and is constant within the elastic deformation regime. Typically, for most metals, Poisson's Ratio is around 0.3 (for a fluid it would be 0.5).

Poisson's Ratio is normally used to describe the deformation of unconfined solids when subjected to compressive or tensile stress. A simple unconfined example would be the compression of a steel cube. In this simple case the Poisson's Ratio is

straightforward to define, the three axial strains being simple to measure and uncomplicated by constraint interference, other than any lateral constraint exerted by the compression apparatus¹. In the case of soil block compaction this is not the case, lateral soil strain is much reduced by the constraint of the mould-wall.

The mould-walls' restraining influence complicates the model as the wall is stiff but not completely rigid. If the wall were completely rigid no lateral expansion of the soil would be possible. The wall would however experience a certain fraction of the applied vertical stress as determined by the soil's Poisson's Ratio. Since the wall is not completely rigid it deflects under the influence of this lateral stress. As the wall deflects lateral soil strain occurs which reduces the stress acting on the wall. There should then exist a balanced condition where the restraining force exerted by the wall is equal to the outward force due to the residual soil stress.

What effect this residual soil stress will have is unclear. The walls' restraining force may be considered as producing a lateral compressive force which in turn would produce a vertical stress opposing the initial compaction force. Mathematical analysis is complex as the order in which the strains take place affects the final shape and resultant stresses.

Soil compaction may be described by this Solid Model provided that the soil's Poisson's Ratio is assumed to change as the compaction cycle progresses. During initial compaction (say up to 10% of the final compaction pressure) a large reduction in block height takes place, typically 80-90% of the total, with almost no measurable lateral strain. This indicates largely plastic flow; on the removal of the compacting force only limited recovery takes place (typically 1-3 mm, 1/80th of the total

¹ If the constraint exerted by the force application apparatus is significant then barrel-shaped deformation is seen. Lower lateral deflection occurs in the vicinity of the constraint.

deflection). As the block height reduces further the amount of relaxation expansion increases.

If the Poisson's Ratio was assumed to be initially zero or near zero (pure plastic deformation) and to increase progressively as the soil density increases during compression then, provided that mould wall and piston face² friction may be neglected, a uniform mould side-wall pressure distribution would be expected. For a very stiff mould, the magnitude of this pressure would depend mainly on the applied vertical stress and the Poisson's Ratio of the soil and would be only marginally reduced as a result of the lateral deflection of the mould. As the applied stress increases so the soil density and Poisson's Ratio increase. The rate of increase in lateral mould wall pressure would then be determined both by the rate of increase of the applied vertical stress and by the rate of increase of the Poisson's Ratio.

The effect of cycling the moulding pressure on this model is unclear, as the order in which the depressurisation strains would occur is indeterminate yet this order determines the pattern of subsequent pressure distributions.

4.2.4 FRICTIONAL POISSON FLOW MODEL

If the concepts of mould-wall friction and Poisson's Ratio are amalgamated then a further model may be formulated. Vertical compression of a laterally constrained soil results in an outward force by the soil upon the mould-walls (whose size depends on both the compressive stress and the local value of Poisson's Ratio). This in turn generates a friction force opposing the downward movement of soil past the mould walls, thereby reducing the compression attained in the lower layers of the block. Initially the Poisson's Ratio is low and this mechanism is slight. However once some compaction is achieved the Poisson's Ratio rises and the mechanism

² If piston face friction is sufficient to cause a lateral constraint, then a barrel shaped pressure distribution would be expected.

rapidly intensifies. The outcome is that higher soil layers are both more compressed than lower ones and have higher Poisson's Ratios. For both these reasons the lateral pressures on the mould-walls is higher near the piston than it is nearer the base plate.

On decompression this model would predict that the region of the block nearest to the moving piston must be the first to decompress and that decompression would progress away from the moving piston as subsequent layers' mould-wall friction was reduced.

4.2.5 EFFECTIVE-PRESSURE MODEL

The concept of effective pressure, found in the field of soil mechanics, may be used to formulate a final compaction model. Effective pressure is used to describe the behaviour of a partially saturated soil under relatively rapid loading³. A partially saturated soil is one which contains both air and water in the pores between soil grains. As a soil in this condition is loaded, the applied force is initially taken by the soil skeleton which is made up of the solid soil grains. At this point total and effective stress are the same. As the applied load is increased the soil grains move into more intimate contact, increasing the number of particle contact points and the soil density. In conjunction with this, air is expelled from the pore voids so that the volume fraction of pore water increases. When all or nearly all of the pore air is expelled, the soil grains begin to experience hydrostatic pressure. Once hydrostatic conditions occur the effective stress (i.e. that born by the solid skeleton) stays constant and any increase in total stress is taken by increased pore water pressure. No further densification of the soil will result unless the pore water can migrate away.

For block compaction the Effective-Pressure Model assumes that the largest material movement exists in the region of the block closest to the moving piston and

³ Relatively rapid here means sufficiently fast to allow an increase in the pressure of water contained in the soil pores.

that this area experiences a higher initial wall shear friction in a Poisson-type manner as above. As this material is compressed by the moving piston, pore air is expelled. The upper central area of the block may then be expected to possess high density, low permeability and small pore sizes, relative to the lower areas of the block. As the compaction pressure increases further, the centre of this area would then be expected to be the first to become sufficiently saturated with water to develop significant pore pressures.

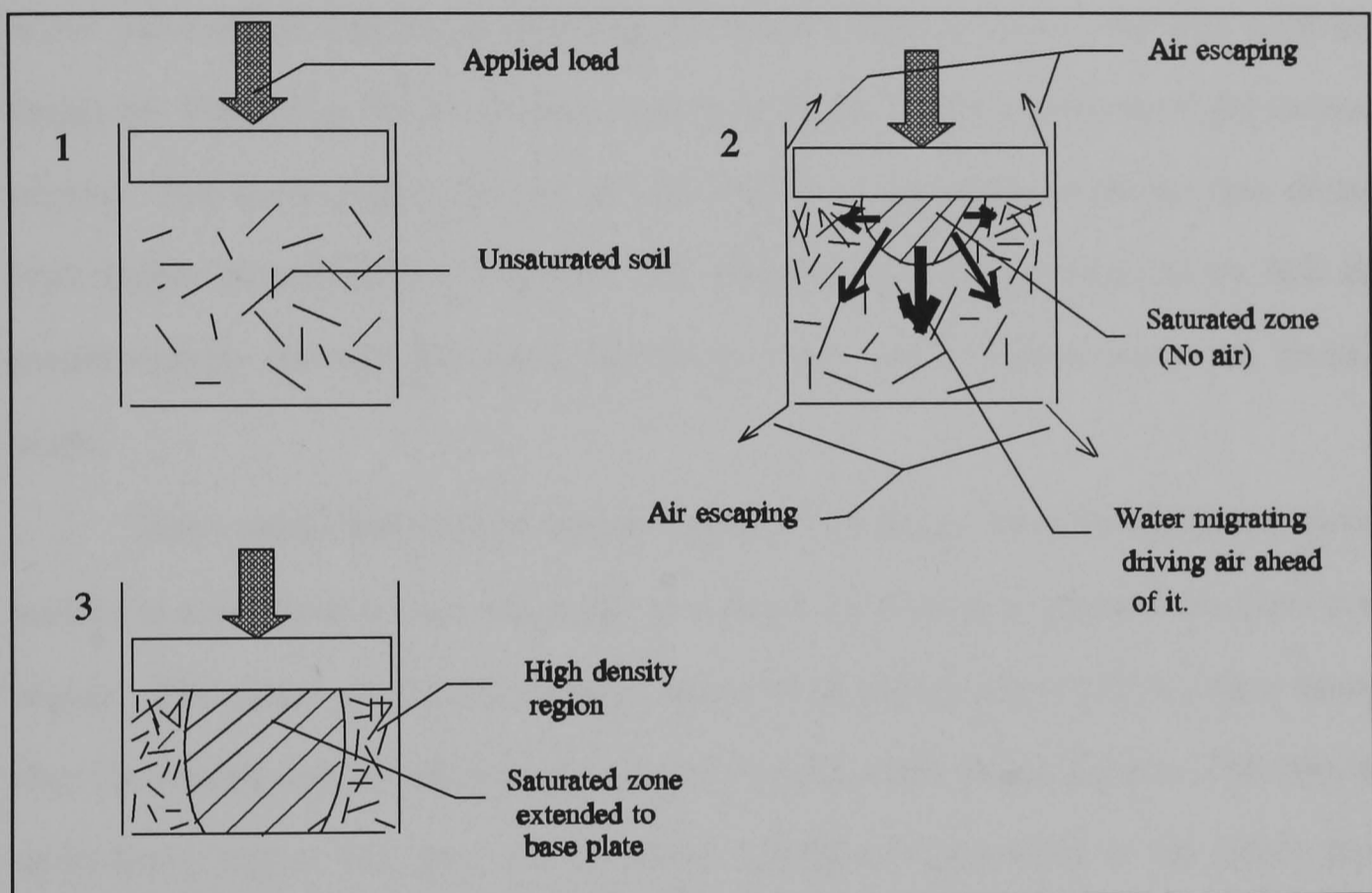

Figure 4.2.5 Schematic representation relating to the effective-pressure model, showing the migration of the saturated zone during compaction.

Once pore pressures begin to develop, the concept of total and effective stress may be used to allow the saturated material to resist higher confinement pressure without further compaction. The edges of the moving piston and of the mould base are open to the atmosphere and so these must maintain atmospheric pressure. As soil is compressed the air contained in its voids will move towards these areas of low pressure. This air movement will result in regions close to these edges remaining only

partially saturated and hence able to undergo further compaction. Meanwhile the saturated hydrostatic condition in the upper central region of the block will result in a hydraulic (i.e. pore water) pressure equal to the difference between the total and effective stresses. Although attenuated through inter-particle friction this additional lateral pressure will further increase the frictional wall shear and hence reduce the build up of total stress in lower regions of the block. As the compaction progresses the pore pressure in the saturated central region will continue to increase. The pore water will continuously but slowly migrate towards regions which were only partially saturated, displacing the air in them and resulting in a slow extension of the central region. The lower regions of the soil will be less compacted and hence less dense with higher permeability. Therefore the extension of the saturated region will be predominantly towards the lower stationary piston rather than towards the mould walls.

This model then predicts that the centre of the upper and central block regions will be in a saturated or near saturated condition with a pressure gradient out from this region. The upper areas of the block closest to the piston edges will be more dense than the central regions which will be more dense than the lower regions. The central hydrostatic region will produce increased mould-wall pressures in the upper and central block areas.

4.3 INTRODUCTION TO QUASI-STATIC EXPERIMENTATION

Blocks are commonly moulded in a single cycle by moving a piston down into a parallel-sided mould containing the soil mix. The mould-walls may have some roughness due to machining during manufacture, and this may increase due to soil abrasion during use. This common moulding process was examined in detail to increase the understanding of confined soil compaction and evaluate the above models. It was subsequently taken as a datum ("standard compaction"), against which the

effect of variations in moulding parameters may be judged. The following section describes the research which was undertaken to investigate the effect of the following moulding variations:

- Double-Sided Compaction (instead of single-sided)
- Mould-Wall Friction (high verses low)
- Mould-Wall Taper (instead of parallel-sided mould)
- Pressure Cycling (instead of simple compression)

The effects of the changes in moulding parameters were observed by measuring the mean density of the resultant block and the pressure transmitted to the mould wall through the compacting soil. The transmitted pressure was recorded by placing an LVDT-based pressure transducer (designed in-house) in seven separate locations in the mould wall and mould piston (see figure 4.4b). The compacting pressure was applied in discrete increments up to 10 MPa. At each increase in load the block height, mould-wall deflection and transmitted pressure were recorded. Details of the experimental method and the experimental instrumentation are included in appendices D and E. Experimental readings are included in appendix F.

The pressure transmitted through the soil to the bottom of the mould was taken as a key variable that should correlate strongly with block density and subsequent cured block strength. The pressure transmitted to the mould walls gives an indication of the state of the soil during compaction. Measurement of the pressure within the body of the block was considered but found to be too complex to reliably instrument.

The initial testing was conducted on blocks made without the use of cement so that the material could be reused and the testing procedure would be less time dependant. Moreover, without the addition of cement the soil mix has a higher internal friction⁴ and therefore amplifies the effect of the changes in pressing

⁴ The fine cement particles appear to act like a dry lubricant during quasi-static compaction. Without cement the soil mix displays higher internal friction.

parameters. It has been assumed that although the magnitude of the variation in the observed parameters will be different for cement mixes, the pattern of change will be similar. Any variation apparent in a non-cement mix is likely to be present in a mix containing cement, but to a lesser degree.

The moulding parameters which were examined were those which appeared to have the most potential to effect the transmission of applied pressure and hence those most likely to affect the final block density. The purpose of this investigation was threefold:

- to assess whether any alternatives to the datum moulding configuration provide a significant improvement in the density of the compacted block on ejection from the mould
- to better understand the mechanism of confined soil compaction and the forces which must be withstood by the mould walls during compaction
- as a base from which to judge any improvements found by using dynamic compaction.

4.4 SINGLE-SIDED COMPACTION - THE DATUM PROCESS

The first case which was examined was that of single-sided compaction. This is used as the datum against which to compare the other cases. Figure 4.4a shows the pressure variation as recorded by the LVDT transducers⁵. The pressure applied to the top face of the block, via the piston, was increased in eight 5 tonne steps to simulate a uniform increase over time. It was then reduced in four steps of 10 tonnes back to zero (1 tonne force corresponds to a mean pressure of 0.24 MPa on the top face of the block). After each step pressure and displacement readings were made, the applied

⁵ The detailed description of the performance, calibration and location of the LVDT transducers is given in appendix D.

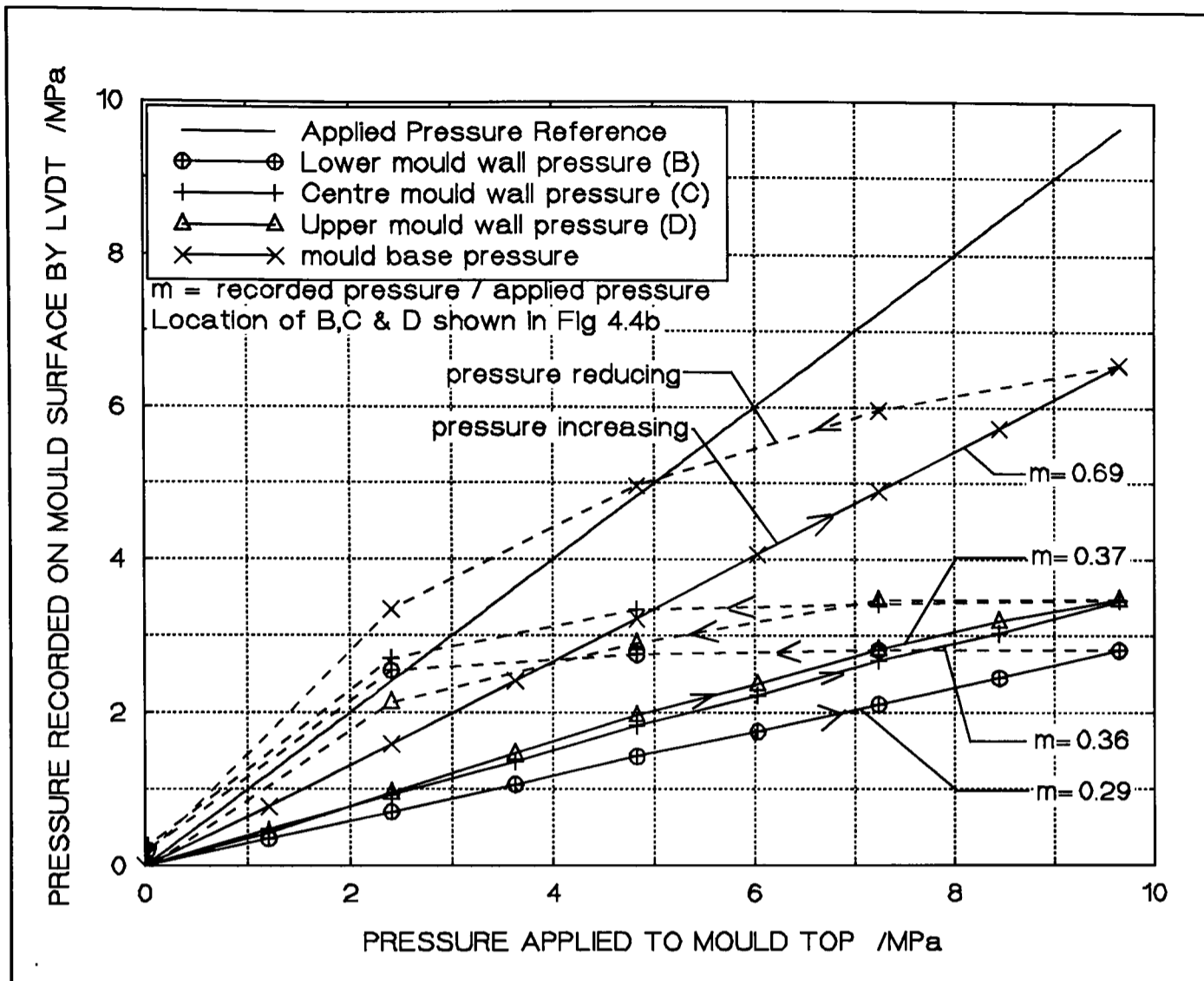

Figure 4.4a The effect of applied top compaction pressure on pressure transmitted to the mould by the compacting soil. (For a standard-size block compacted under standard conditions).

pressure being held constant for long enough for these readings to stabilise (quasi-static process). Pressure recorded on the block wall is plotted against pressure on the mould top (applied pressure calculated from the applied force and the known area of the mould surface). Only one transducer was initially available whose location could only be changed after pressings. Hence the traces in figure 4.4a are actually the amalgamation of eight separate block pressings, each trace being the average of two presses.

The maximum pressure readings agreed surprisingly well (within 0.25 MPa) between pairs of blocks. A plot of the applied top pressure has been included in the figure for ease of comparison and plots as a straight line with a maximum of 9.66 MPa (40 tonnes applied to the largest block face). In general the internal pressures

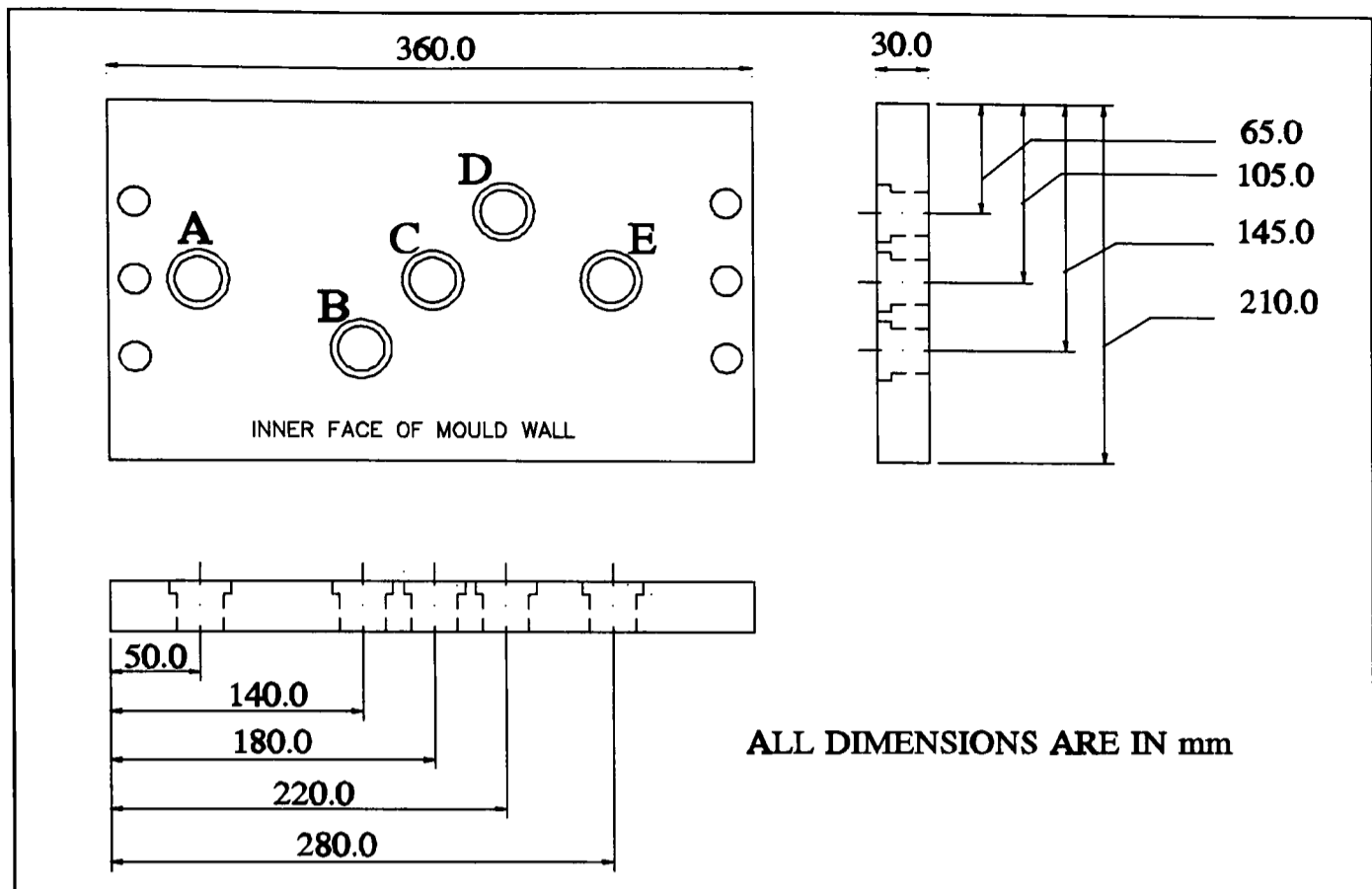

Figure 4.4b The location of LVDT transducers in the mould wall.

throughout the mould increase linearly with the applied top pressure but with differing rates of "gain" around the block (see table 4.4; "gain" = local pressure / top pressure). The transducer on the mould base recorded the highest pressure gain of 69%, rising to a maximum of 6.7 MPa; compared to the applied 9.7 MPa this represents a loss of 3 MPa. The transducers located at the upper and central regions (see figure 4.4b, sites D and C respectively) of the mould side-wall both gave recorded maximum pressures close to 3.5 MPa (3.51 MPa for the upper region and 3.48 MPa for the central region i.e. gain = 36%). However the lower centre side-wall transducer, location B, recorded a maximum pressure of only 2.8 MPa (gain = 29%). The pressure distribution along the length of the block at mid-height was also recorded using the three transducer locations A, C & E see Fig 4.4 b. The respective maximum pressures were 3.5, 3.5 and 3.9 MPa (gain of 36%, 36% and 40%) indicating little variation until the corner of the mould is approached.

Table 4.4 Average Transmitted Pressure Recorded by Static

Location of LVDT	Average Max Pressure /MPa	95% Confidence bounds	Pressure Gain %
Base	6.67	6.40..6.94	69
Upper Side	3.51	3.47..3.55	36
Centre Side	3.48	3.14..3.83	36
Lower Side	2.80	2.75..2.86	29

The pattern of quasi-static pressure reduction was also recorded. The mould base pressure begins to drop off as soon as the applied top pressure is reduced and continues to reduce at an increasing rate. Although a strong hysteresis pattern is exhibited there is no residual bottom pressure when the top pressure is returned to zero.

The mould wall pressures also fall back as lag curves. There is a lag between when the applied pressure is reduced and when the mould wall pressures begin to drop significantly. Thus the top pressure has to have fallen by about 25%, 50% and 75%, before there is a noticeable fall in the lateral pressures on the top, centre and bottom of the sides respectively. Again despite this hysteresis behaviour, on final removal of the top pressure all the side pressures also fall to approximately zero.

The material inside the mould under full (9.7 MPa) compression will have undergone both plastic and elastic deformation. Large plastic deformation is evident from the significant volume reduction, typically 1.5:1. Elastic deformation is also apparent, although less pronounced, by the increase in block height as the applied load is removed (see Fig 4.4c).

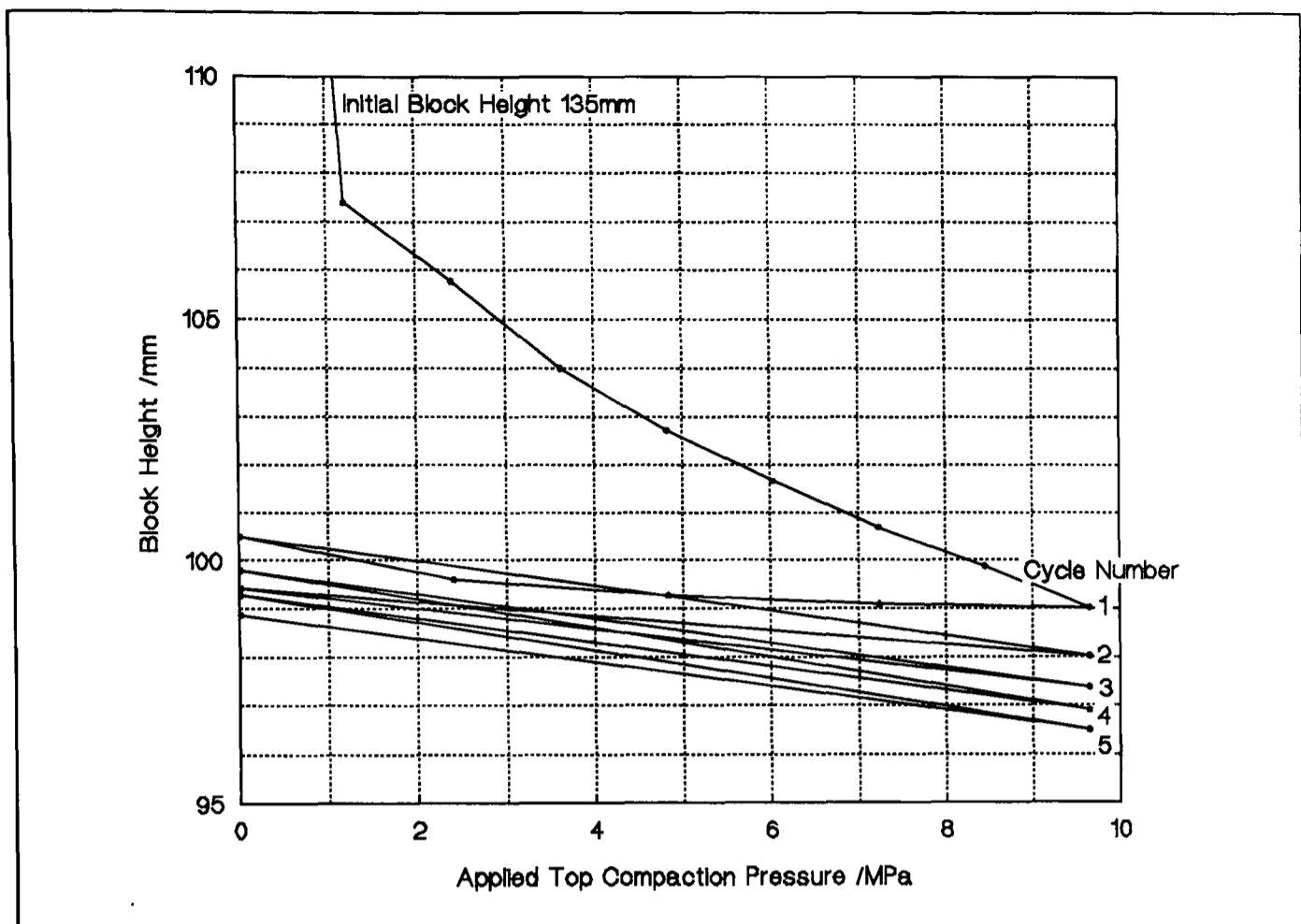

Figure 4.4c The effect of top pressure on block height during initial compaction and 4 subsequent full pressure cycles. For a standard-size block, all other conditions are as for standard compaction.

4.4.1 ANALYSIS OF THE SINGLE-SIDED COMPACTION PROCESS

The pattern of mould wall pressure distribution recorded on compression clearly indicates that the *Simple Hydrostatic Model* is inadequate. The soil does not achieve a uniform distribution of pressure, neither during compression nor decompression.

The *Pipe Flow Model* predicts that until equilibrium is reached the mould base pressure should be less than the applied compaction pressure and that the lateral pressure acting on the mould side-walls should decrease with distance from the compacting piston. A drop in lateral pressure is indeed apparent between the top and bottom of the mould but the rate of pressure drop is non-uniform, the lateral pressure in the centre of the mould side-wall is the same as that in the upper region. Moreover under a sustained static loading neither the mould side-wall nor the mould base

pressure tend towards a hydrostatic condition. It could be that under full compaction the soil has become so viscous that the time for which the static load was maintained was insufficient to show this trend. However this seems unlikely as even after sustaining the applied maximum load for twenty minutes no trend towards hydrostatic conditions was apparent.

The *Solid Poisson model* would predict a barrel-type pressure distribution (for a uniform Poisson's Ratio) with side-wall pressures lower in both the upper and lower mould regions than in the central region. If it were assumed that the Poisson's Ratio in the upper mould region was higher than that in the lower region, as a result of increased material compaction, an increase in the upper mould side-wall pressure might be expected. However without the inclusion of frictional shear with the mould-wall (see *Frictional Poisson Flow Model*) it is difficult to explain such a change in Poisson's Ratio.

On decompression the *Solid Poisson Model* would predict that the lateral pressures would decrease simultaneously, rather than showing a pronounced lag pattern. Therefore this model also appears inadequate.

The *Frictional Poisson Flow Model* allows increased material compaction in the upper mould region to locally increase the Poisson's Ratio in this area so that a significant lateral deflection of the soil material may result in significant frictional shear, hence reducing the compaction force seen by lower regions of the mould. This model predicts that the lateral pressure would decrease with distance from the compacting piston. However if end constraint is also significant then it would be expected that the upper region, in contact with the compacting piston, would display lower lateral strain and hence lower lateral pressure. Such an end constraint could then partially explain why the upper mould region might display a similar lateral pressure to the central region.

On decompression the pattern of mould pressure fall indicates a pattern which is compatible with the Frictional Poisson Flow model. As the applied pressure is reduced so those regions of the block nearest to the moving piston begin to decompress. In the upper regions of the block this decompression takes place initially in the vertical direction, the direction of movement. The resulting elastic expansion of the material is vertical as the mould maintains a lateral constraint. When the applied load is reduced the frictional shear stress acting on the mould-wall reverses direction to *oppose the upward movement* of the contained soil. This movement relieves the lateral stress which is being applied to the mould side-walls. As the lateral stress in the upper region of the mould reduces so does the restraining frictional shear stress with the mould wall. The consequent reduction in restraining mould wall friction then effectively reduces the vertical constraining force, allowing the lower regions of the block to decompress. As the applied pressure is reduced further so the region of elastic expansion moves downward.

The upper region of the block, being the nearest to the moving piston during compaction, would be expected to be in the most stressed/compacted state, with the highest Poisson's ratio. Therefore it could be assumed that this region would exhibit the largest recovery and consequently the most rapid rate of reduction in side-wall pressure and restraining friction. The central region of the block would be in a similar condition but could not begin to significantly decompress until the upper layer's vertical restraining influence had sufficiently diminished. This would then result in an effective lag in lateral decompression which would increase with distance from the moving piston i.e. towards the lower regions.

The *Effective-Pressure Model* agrees with the recorded pressure distribution pattern seen during compression. However during decompression it would predict that vertical expansion due to a reduction in vertical stress would increase the permeability of the soil material and allow any hydrostatic or near-hydrostatic areas to quickly

reduce in pressure. This reduction in pressure in the central block regions would then be expected to result in a quick reduction in the lateral pressure acting on the mould-walls. Once the central region had lost its hydrostatic pressure and become able to export its pore water, it would be further compressed by the relaxation of the mould-walls. This model would indicate that decompression would not be delayed by the gradual progressive reduction in mould wall friction, so it would not predict the lag in decompression seen in practice.

None of the models exactly describe the actual pattern of pressure distribution seen. The *Frictional Poisson Flow Model* correlates most closely if an end constraint phenomenon is included however this model too appears lacking when the pattern produced on applied pressure cycling is considered (see below).

4.5 DOUBLE-SIDED COMPACTION

There are various ways of applying "double-sided" pressure. The one used here was to fix the base plate, move the top plate (piston) and to let the side-walls of the mould "float". An exact equality of top and bottom pressures was not achieved, as it might have been with mechanically linked top and bottom pistons. The base pressure rose and fell linearly with top pressure but with a gain of only 0.81 instead of 1. Perfect double-sided compression might have raised the side-wall pressure a little higher, probably to about 50% of the applied piston pressure.

The plot of applied pressure against recorded pressure is shown as Figure 4.5. The arrangement of the double-sided compaction rig was such that only the central side-wall and base pressures could be recorded. Both of the recorded pressures were seen to be significantly higher than for single-sided, 7.9 MPa and 4.4 MPa for the base and centre-side respectively. This represents a 12% increase in mould base

pressure and a 9% increase in mould side-wall pressure (to 81% and 45% of applied top pressure respectively).

This would appear to clearly indicate that double-sided compaction was more effective in compressing the block. However, although significant in terms of pressure transmission for a high internal friction mix (no cement), when 5% cement was added

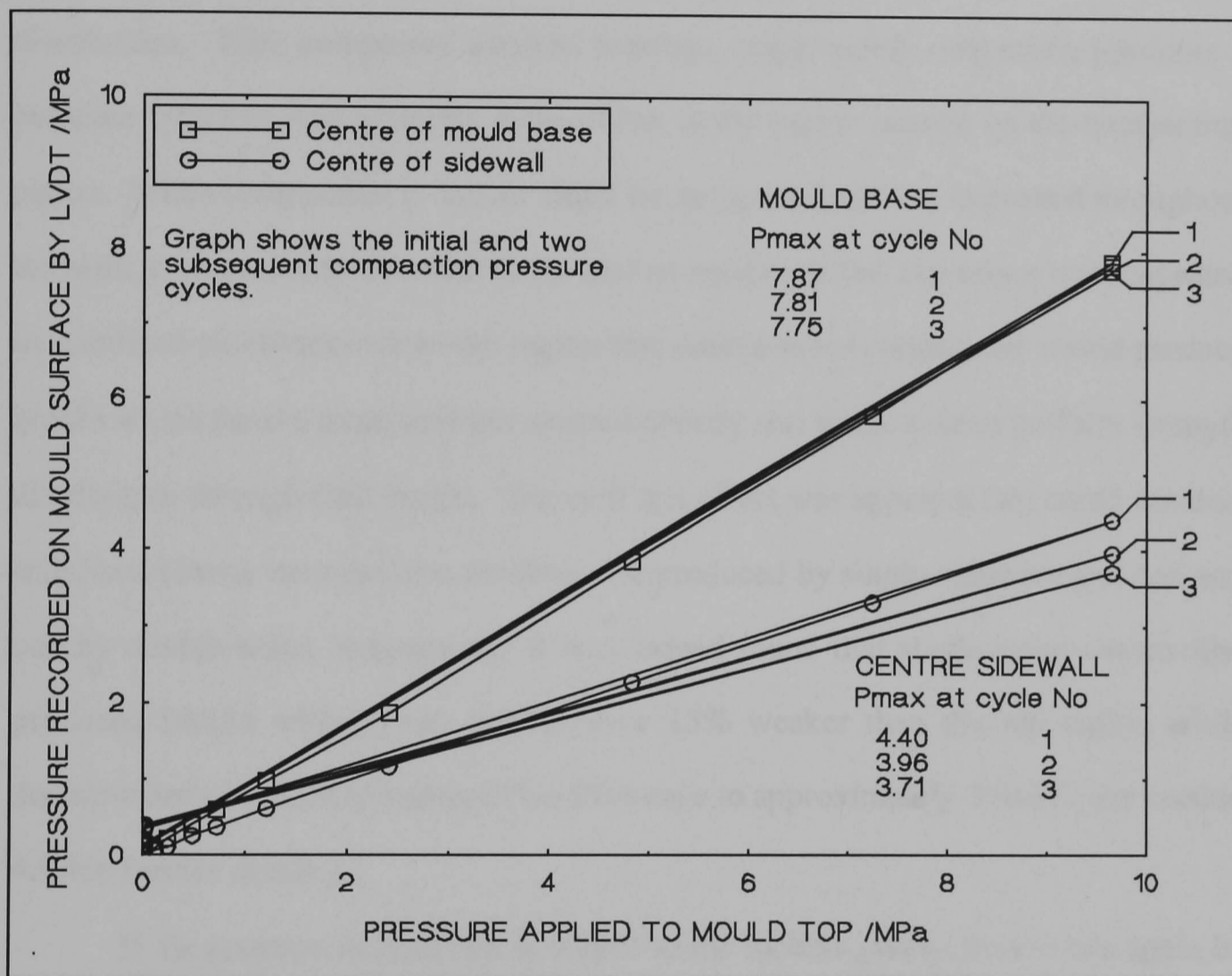

Figure 4.5 The effect of double-sided pressure application on the pressure transmitted to the mould. For a standard-size block under going 3 full cycles, all other conditions as standard compaction.

to the mix the pressure difference between single-sided and double-sided reduced to 10% and 5% for base and centre respectively.

Having initially stated that by using a soil mix without cement the internal friction would be higher, the difference between the above cases with and without cement should be expected. The apparently large increase in transmitted pressure for the no-cement blocks translates into only a small increase for the cement blocks.

Furthermore, when these cement-stabilised blocks were tested for wet compressive strength after seven days of damp curing, the single-sided ones gave an average of 2.84 MPa (std 0.076) while the double-sided ones gave an average of 3.04 MPa (std 0.087). This represents a statistically significant increase in wet compressive strength but only of 7%.

This increase in strength may suggest a more uniform internal density distribution. With compacted sintered bearings, single-sided compaction produces a compact which is demonstrably more dense in the region nearest to the compacting piston. When compaction is double-sided the compact density is improved throughout but with a reduced improvement in the central region. If this behaviour were repeated in stabilised-soil blocks we would expect that double-sided compaction would produce blocks which have a more uniform internal density and hence a more uniform strength distribution through their height. To see if this effect was apparent two cured cement-stabilised blocks were cut into sections, one produced by single-sided compaction and one by double-sided compaction. It was indeed found that single-sided compaction produced blocks whose base regions were 15% weaker than the top region while double-sided compaction reduced this difference to approximately 0 (0.4%, see section 4.9 for further details).

If the pressure distribution is related to the models given above it can again be seen that both the *Simple Hydrostatic* and *Pipe Flow Models* are inadequate as no equalisation of pressure is evident. The increase in base and mould-wall pressure would be expected from both *Poisson Models* and the *Effective-Pressure Model*. As no pressure data was obtained for the upper and lower mould wall regions no further differentiation may be made between these models.

Double-sided compaction is more effective than single-sided compaction, as is clearly shown by the increase in both base and mould wall pressures. However the partially double-sided compaction of these experiments gave an increase of only 7%

in 7-day wet strength. Perfect double-sided compaction might achieve a 15-20% increase. The additional mechanical complexity and associated cost required to produce a commercial double-sided block press would appear unwarranted by such modest improvements.

4.6 REDUCTION IN MOULD-WALL FRICTION

The effect of reducing mould-wall friction was examined by lining a parallel-sided mould with a twin thickness of plastic sheeting, separated by a lubricating oil film. Figure 4.6 shows the plot of side and bottom pressure against the top pressure applied via a single moving piston. (Lining the mould with plastic was appropriate

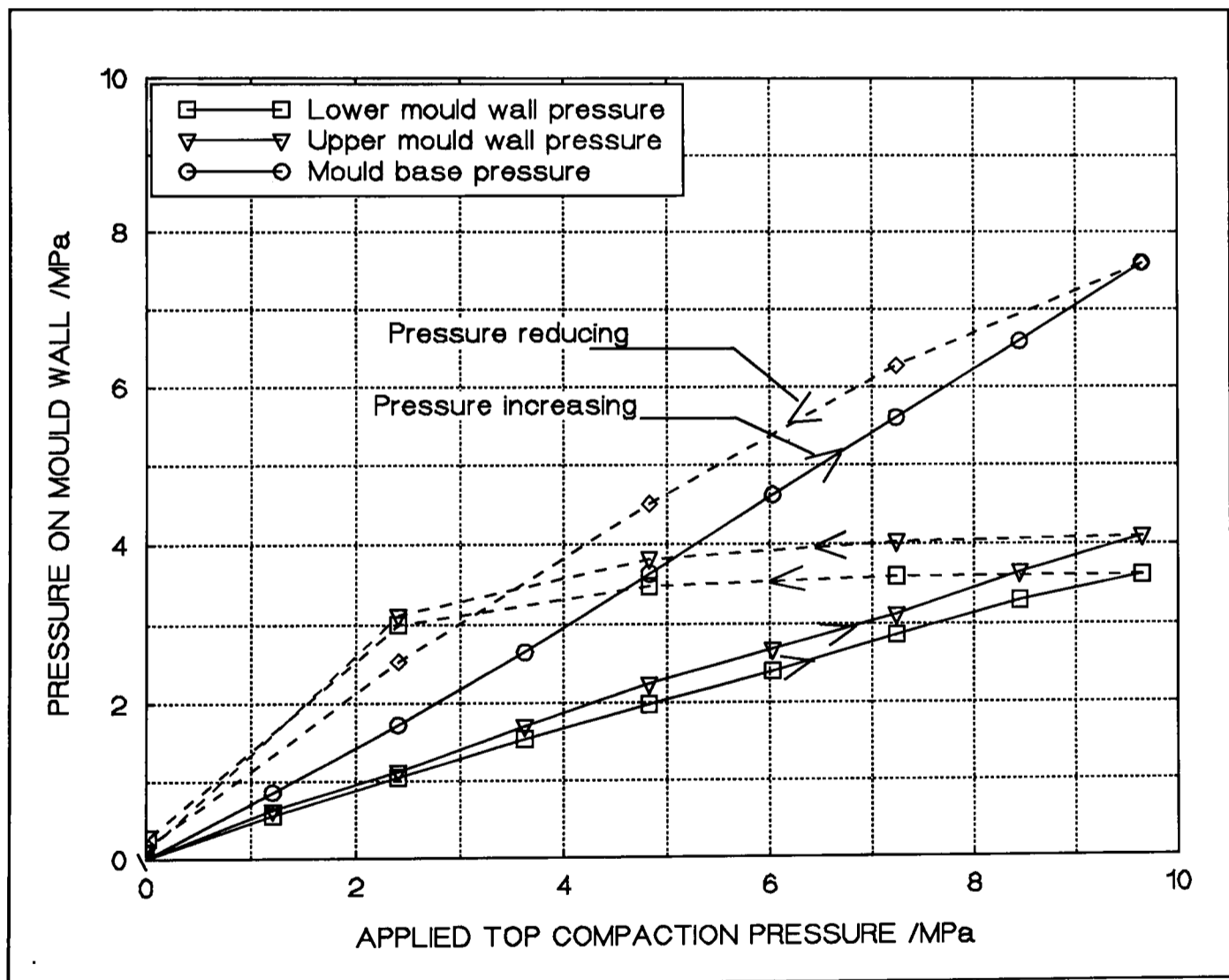

Figure 4.6 The effect of smooth walls on applied top pressure transmission. For a standard-size block, all other conditions are as standard compaction.

as an experimental technique but would not be recommended for field use.) During compaction the inner layer of plastic was dragged down with the compacting soil and forced to ruck into the body of the block thus producing slightly flawed blocks. However, this should not invalidate the pressure transmission data gathered.

Both the base pressure and the two recorded mould wall pressures were seen to rise significantly compared with the much rougher datum process illustrated in Figure 4.4a. The base pressure rose to 7.6 MPa whilst the upper and lower mould wall pressures rose to 4.1 and 3.6 MPa respectively. These represent increases of 14%, 17% and 29% over the standard (rougher wall) case. Again it would be expected that this would translate into an increase (albeit lesser) in the final wet strength of the blocks and shows that mould wall friction plays an important role in determining the effectiveness of the applied pressure in block compaction. It is therefore recommended that the mould should be as smooth as possible and that any machining marks etc. should be orientated in the direction of the soil material movement during compaction i.e. perpendicular to the compacting piston.

4.7 MOULD-WALL TAPER

Mould-wall taper was investigated by angling the mould side-walls to first 1° then to 5° from the vertical. In all other respects the mould and moulding procedures were as for the single-sided datum process in section 4.4. The taper was produced by separating the mould-walls and bolting them in place with tapering sets of shim steel to produce the desired angles. The mould was arranged such that the moving piston applied pressure from the larger side of the taper. Figure 4.7 shows the plot of applied pressure against recorded pressure. The base pressure was seen to rise slightly to 6.9 MPa (+3% compared to the single-sided datum) but this was believed to be a function of the experimental method. The same dry mass of soil was used to produce each block throughout the set of tests and as a result of the manner in which the

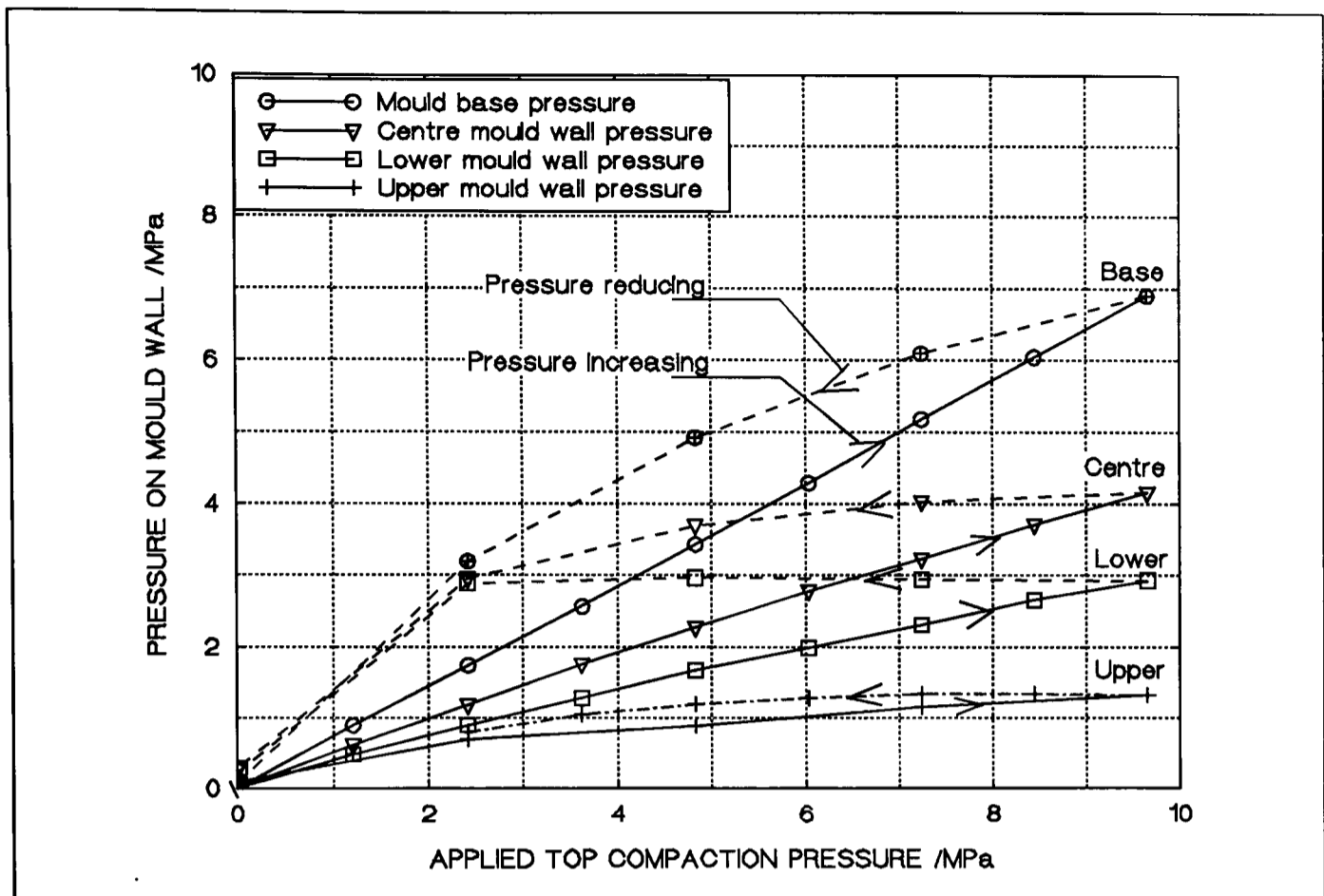

Figure 4.7 The effect of 1° mould wall taper on applied top pressure transmission. For a standard-size block, all other conditions as standard compaction.

mould was tapered, the final block height was reduced by about 4.5%. Therefore some increase in base pressure would be expected as the height through which the applied pressure was acting was reduced. The mould side-wall pressures were also recorded. The upper region pressure was significantly lower than that for the standard mould configuration, however the readings from the pressure transducer in this upper wall position were rendered unreliable by the transducer now being incompletely submerged in soil. The central and lower region pressures were slightly increased, at 4.2 and 2.9 MPa but not above what might be expected as a result of the increase in projected area seen by the compacting material. The 5° taper mould produced similar results; the base pressure increased to 7.5 MPa (+12% compared to the single-sided datum) while the central wall pressure increased to 4.4 MPa. In this case the final block height reduced by about 20% compared to the datum.

In conclusion, mould taper does not have any significant beneficial effect on pressure transmission. The ejection of blocks from a tapered mould however required

much lower forces than for a parallel-sided mould and these forces had to be sustained for a much shorter period of time. Taper may therefore be used to ease ejection but the somewhat awkward shape of the blocks does not seem to justify the improved ease of ejection. Taper is not recommended for incorporation into block production machines.

4.8 PRESSURE CYCLING

Here the term pressure cycling is used to imply the decompression of a fully pressurised block to various intermediate levels of pressure and its subsequent recompression back to the original pressure.

The manner in which a soil block would respond to applied pressure cycling was unclear. Three alternative outcomes were postulated prior to experimentation:

- the cycling would have no effect on the pressures transmitted to the mould sides and base, the transducers there recording the same value of peak pressure as that recorded for the initial cycle
- the cycling would progressively increase the transmitted pressure to a limiting maximum. The rate of increase in transmitted pressure would depend on the magnitude of the cycle, while the limiting value of the transmitted pressure would remain unchanged; low magnitude cycles would require multiple repetition to achieve the same pressure transmission as a single large magnitude cycle
- the cycling would progressively increase the transmitted pressure to a limiting maximum value. The maximum value would be dependant on the depth of the cycle, pressure cycling from full to zero would result in a higher limit to the transmitted pressure than cycling from full to some partial (greater than zero) pressure.

4.8.1 FULL PRESSURE CYCLING

Table 4.8a shows the pattern of pressure change in the mould side-wall for cycling from 9.7 to 0.1 MPa (effectively zero) for standard single-sided compaction. It can be seen that the base pressure remains almost constant, rising slightly with successive cycles but not significantly. The mould side-wall pressure appears to drop significantly with each cycle, although by less with each successive cycle.

Table 4.8a Pressure transmission on full-pressure cycling (all pressures are expressed as a percentage of the peak applied top pressure)

Cycle No	Maximum applied pressure /MPa	Maximum mould base pressure /%	Maximum upper mould wall pressure /%	Maximum centre mould wall pressure /%	Maximum lower mould wall pressure /%
1	9.66	69.6	36.0	36.7	29.4
2	9.66	70.9	26.4	35.0	23.4
3	9.66	71.7	22.1	33.1	21.1
4	9.66	71.6	19.4	32.9	19.6
5	9.66	71.6	17.8	32.4	18.7

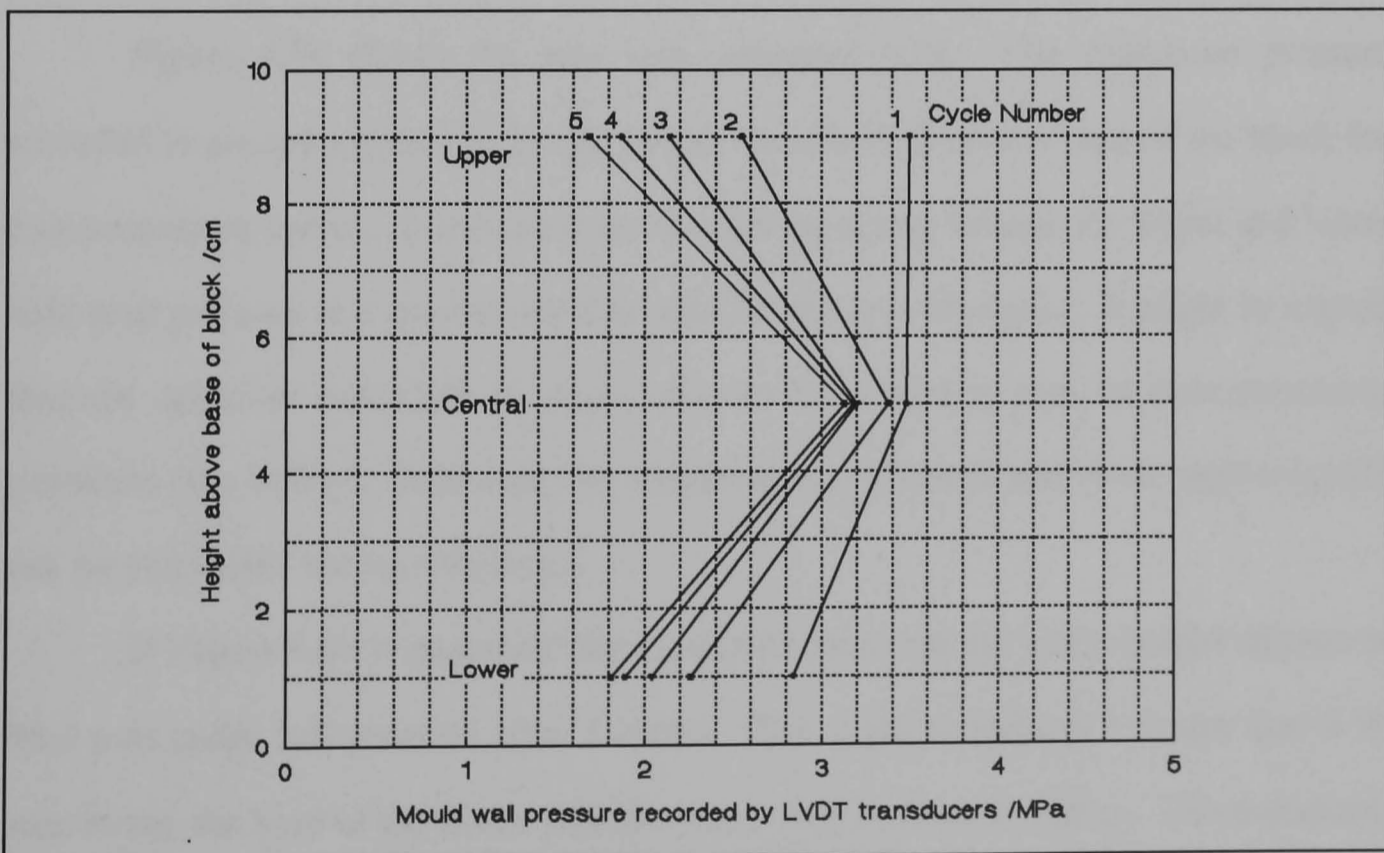

Figure 4.8a Pressure recorded on the mould wall (upper, central and lower) at the peaks of 5 successive full-pressure cycles. For a standard-size block, all other conditions as standard compaction.

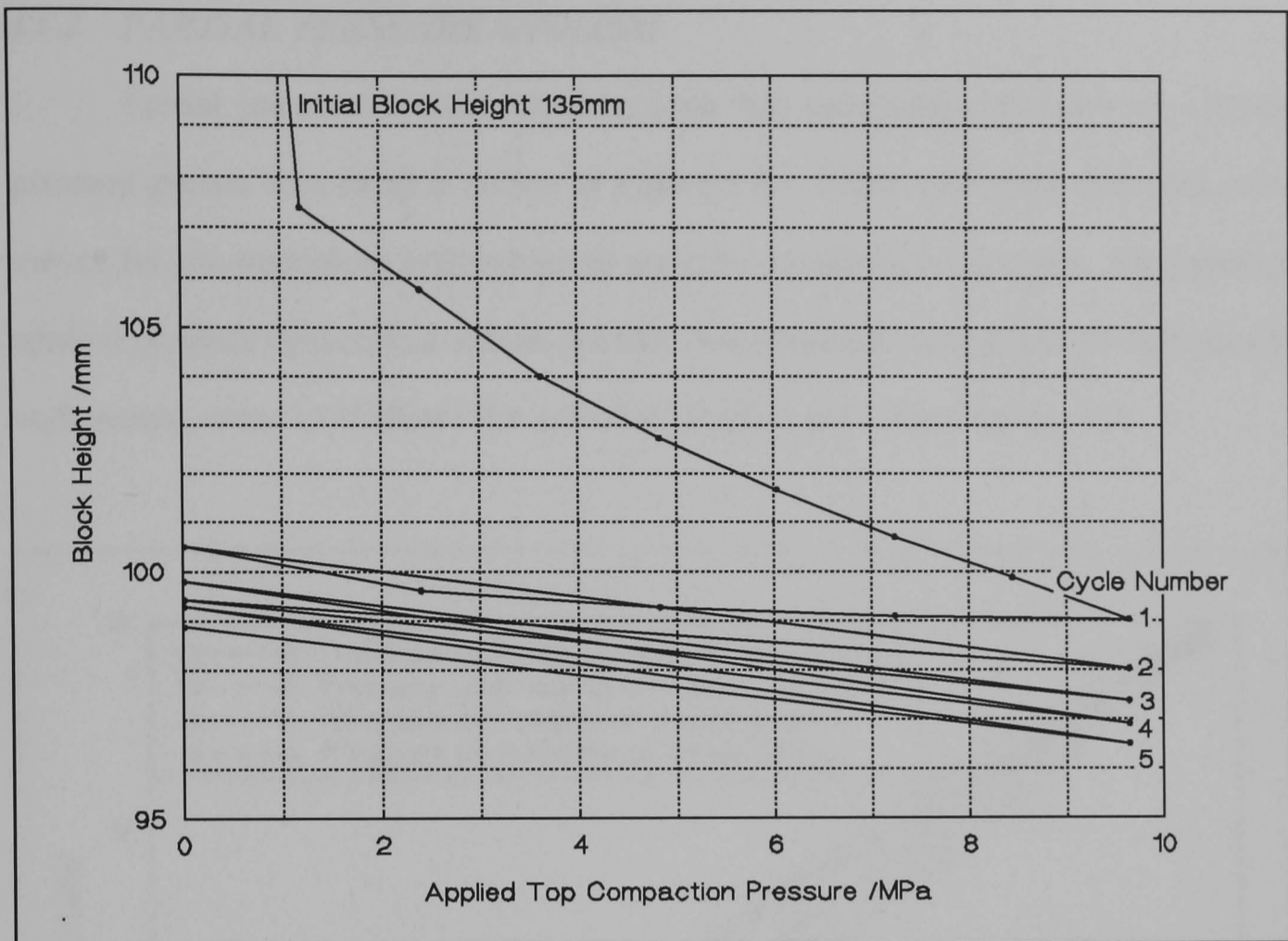

Figure 4.8b The effect of top pressure on block height during compaction for 5 successive full-pressure cycles. For a standard-size block, all other conditions as standard compaction.

Figure 4.8a shows the side wall pressures only. The maximum pressure recorded is plotted against the height of the transducer from the base of the block for five successive cycles. It indicates that the cycling action reduces the upper and lower side-wall pressure at a greater rate than that for the central region. It might be argued that the apparent reduction in upper side-wall pressure is due to instrumentation problems (see below). However, the reduction in the central and lower regions could not be accounted for on this basis.

If Figure 4.8b is examined then it can be seen that the block height reduces to 96.5 mm under full pressure after 5 cycles. The upper transducer's centre line is 90 mm above the base of the block and the active face is 5mm in radius. The transducer is therefore recording the upper side-wall pressure from 3.9-13.9 mm below the upper surface for the first cycle and from 1.5-11.5 mm below the surface for the fifth cycle.

4.8.2 PARTIAL PRESSURE CYCLING

Partial pressure cycling (cycling from full compaction pressure to a lesser pressure greater than zero) is shown as Figure 4.8c. Table 4.8b shows the numerical values for the maximum and minimum pressure values for each cycle. This plot of applied pressure against transmitted pressure was obtained using a (lubricated) smooth wall mould, even so it shows the effect of residual wall shear forces well.

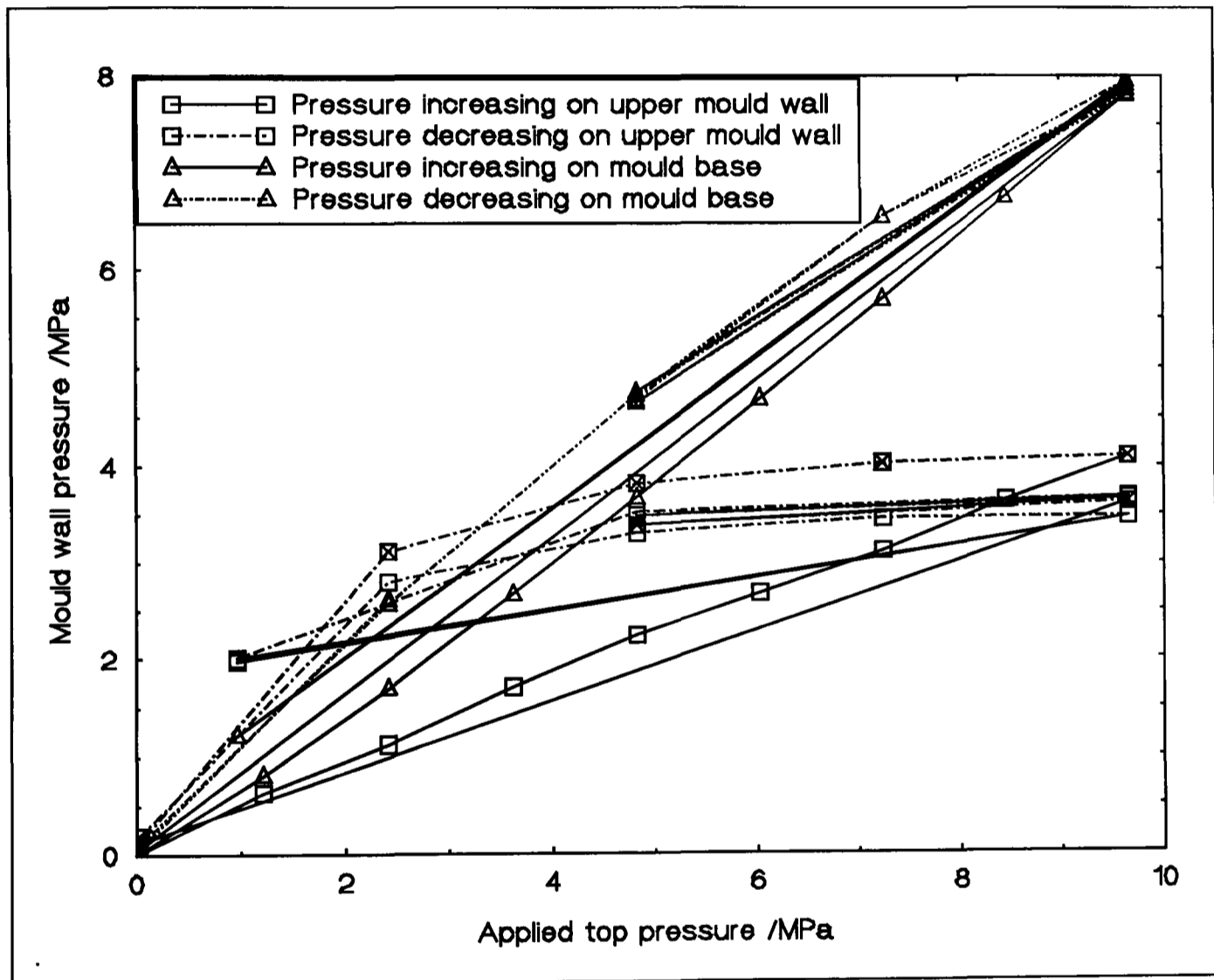

Figure 4.8c The effect of partial pressure cycling on applied top pressure transmission to the mould walls. For a standard-size block, with smooth walls, all other conditions as for standard compaction.

The block shown in Figure 4.8c was cycled in the following manner:

Cycle No	Top Pressure /MPa	Cycle No	Top Pressure /MPa
CYCLE 0	0.1 → 10	CYCLE 3	10 → 5 → 10
CYCLE 1	10 → 0.1 → 10	CYCLE 4	10 → 1 → 10
CYCLE 2	10 → 5 → 10	CYCLE 5	10 → 1 → 10
		END	10 → 0.02

Deep cycling (cycles 1 and 4) produces significant further compaction accompanied by a drop in sidewall pressure. Shallow cycling (cycles 2 and 3) has little effect. This appears to suggest that pressure cycling has little or no effect on a region unless the pressure is dropped back to significantly less than the lag pressure mentioned above (section 4.4).

Table 4.8b Pressure values relating to figure 4.8c

Cycle No	Applied pressure /MPa	Mould base pressure /MPa	Upper mould wall pressure /MPa
0	0.00 → 9.66	0.00 → 7.80	0.00 → 4.10
1	9.66 → 0.10 → 9.66	7.80 → 0.05 → 7.82	4.10 → 0.12 → 3.63
2	9.66 → 4.83 → 9.66	7.82 → 4.64 → 7.86	3.63 → 3.39 → 3.67
3	9.66 → 4.83 → 9.66	7.86 → 4.75 → 7.87	3.67 → 3.49 → 3.68
4	9.66 → 0.97 → 9.66	7.87 → 1.22 → 7.91	3.68 → 2.01 → 3.48
5	9.66 → 0.97 → 9.66	7.91 → 1.22 → 7.95	3.48 → 1.97 → 3.48
UNLOADING	9.66 → 0.02	7.95 → 0.10	3.48 → 0.19

4.8.3 ANALYSIS OF APPLIED PRESSURE CYCLING

The pattern of pressure change on full and partial pressure cycling indicates that none of the three postulates mentioned at the start of this section (4.8) are representative of the actual change in transmitted pressure. The pressure transmitted to the mould base marginally increases on cycling, while side-wall pressures decrease. The values to which the latter decrease depends on the depth of the pressure cycle. The decrease in pressure due to cycling is most pronounced in the upper and lower regions of the block walls.

Of the models which were postulated in section 4.2 neither the *Simple Hydrostatic* nor the *Pipe Flow Model* will be considered since no equalisation of pressure was apparent.

The *Solid Poisson Model* would predict that the Poisson's Ratio of the block would increase with successive cycles as the material became more compressed. This would result in an increase in the mould side-wall pressures while the base pressure remained unchanged. As this is the opposite of what has been recorded by the pressure transducers this model must again be rejected.

The *Frictional Poisson Flow Model* predicted that on first compression, the upper mould side-wall pressure would be higher than the central side-wall pressure, though less so if an end constraint were significant. It further predicted that this central side-wall pressure would in turn be higher than the lower side-wall pressure.

On subsequent re-application of full pressure it would be expected that the upper region of the block, being the most compacted, would be stiffer than the lower regions of the block. Having a greater stiffness the compressive strain experienced by this layer would not become significant until the lower layers could exert a moderate resistive force. In this way the increase in lateral strain of the upper layers of the block would be delayed. Hence the frictional wall shear would also be reduced and consequently a greater proportion of the applied load would be passed on to lower layers of the block.

As the lower layers of the block experience a larger compressive force they will become compacted and increase their Poisson's Ratios thereby generating increased mould side-wall pressure. In the same manner as the initial compaction cycle, the central block region would be expected to display higher lateral pressure than the lower region. With successive cycles this area of high lateral pressure would be expected to spread towards the bottom of the mould.

As the effective area for frictional shear with the mould side-wall reduces slightly with each successive cycle (as the block height reduces) it would also be expected that a slightly greater fraction of the applied load would be passed on to the mould base.

Partial pressure cycling would be expected to exhibit a similar pattern of pressure change, however the magnitude of the lateral pressure change would depend on the degree of decompression. This model predicts a lag in decompression as a result of sustained frictional shear with the mould walls (see above). Lower layers of the block only decompress significantly once the frictional shear of upper layers is sufficiently reduced. On partial pressure cycling lower layers of the block experience a reversal of the direction of the frictional shear without a change in confinement pressure. Hence only those layers which experience a significant reduction in shear force would be affected by partial pressure cycling.

In short, this model predicts that on full pressure cycling the upper mould side-wall pressure should reach a limiting value which will depend on the limiting value of the Poisson's Ratio for the compacted block. The region of high lateral pressure should progress down towards the base of the block with successive cycles, increasing the lower side-wall lateral pressure and the pressure transmitted to the mould base.

The pressure pattern predicted by this model for full pressure cycling has not been observed. Although the mould base pressure marginally increases with successive cycles both the upper side-wall lateral pressure and the lower mould side-wall pressure consistently fall while the central region only marginally reduces. The pattern of pressure distribution seen on partial pressure cycling is in agreement with that observed, to the extent that the degree of lateral pressure change is dependant on the magnitude of the applied pressure cycle and that lower layers of the block are unaffected by this cycling unless decompression is sufficiently large to reduce the magnitude of the frictional mould side-wall shear.

The *Effective-Pressure Model* could account for the pressure reduction in the upper side-wall if it is assumed that the edge region of the compaction piston is at atmospheric pressure (0 MPa on the LVDT scale) and that a region of transition from 0 to 3.5 MPa (max side-wall pressure on the first cycle) exists. As the upper face of the block moves downward approaching the upper LVDT then it might be expected that the region of pressure transition would move with the top piston and hence the recorded pressure might drop. However this would not explain the lower side-wall pressure drop.

Confined soil compaction is not accurately described by any of the models postulated. It would appear that highly complex non-linear phenomena occur during compaction. These phenomena probably involve frictional, effective-pressure and Poisson-type arguments, however their interaction is multifaceted and beyond the scope of this thesis to model further.

It may be concluded that the condition of the soil during compaction is not a simple hydrostatic one. It appears unlikely that the mould side-walls, under datum conditions, ever experience more than 50% of the applied top pressure and normally experience less than 40%. This being the case, significant material savings in mould-wall design stiffness and hence thickness would appear possible. Significantly less than 100% of the pressure applied to the compacting piston reaches the base plate, this may be assumed to be indicative of internal shear and particle/mould-wall friction. The mould-wall shear is significant and may be reduced by smoothing/lubricating the mould-walls. Taper has little or no beneficial effect on the compaction process but it does reduce both the ejection force and the length of time for which this force must be applied. Double-sided compaction does significantly increase final density but the benefit of this would be small compared to the cost of the extra mechanical complexity entailed. An increase in block density is also evident on both partial and full pressure cycling. However no increase in mould base pressure was observed for

low magnitude partial pressure cycling, suggesting that the densification resulting from partial pressure cycling is confined to the upper regions of the block. Full pressure cycling has a more penetrating effect. However full pressure cycling is not possible with simple fixed-volume compaction machines and would be likely to significantly reduce machine outputs if it were implemented in hydraulic fixed-pressure compaction machines. If it is assumed that it takes 20 strokes of the hydraulic ram to pressurise a Brepack compaction machine then four full pressure cycles would add 1 minute 20 seconds to the production of each block and reduce the daily block production rate from 248 to 146, a drop of 40%. The corresponding increase in density would be 2.5% equating to a 13.5% increase in compressive strength determined on the basis of the empirical relation derived in chapter 5, assuming a 5% cement content.

4.9 THE EFFECTS OF QUASI-STATIC SINGLE AND DOUBLE-SIDED COMPACTION ON CEMENT-STABILISED SOIL BLOCKS.

4.9.1 INTRODUCTION

Following the tests reported above, two further sets of four blocks were produced with the addition of cement, one set by the datum process and one by double-sided compaction, these two sets giving the greatest variation in pressure transmitted to the base of the mould. These blocks were allowed to cure for seven days and then tested for wet compressive strength to assess the actual improvement in strength resulting from double-sided compaction. Three of the blocks from each set were cut in half, each half was then tested independently for wet compressive strength while the fourth blocks from each set were sectioned as shown in figure 4.9.3.

4.9.2 THE COMPRESSIVE STRENGTH OF CEMENT-STABILISED BLOCKS COMPACTED BY SINGLE AND DOUBLE-SIDED COMPACTION METHODS

The compressive strength values found for the blocks which were cut in two is given in table 4.9.2 the letters A and B denoting the two halves of what was originally one full-size block. It was found that double-sided compaction increased the block density from 2086 kg/m³ to 2103 kg/m³ and block strength from 2.84 MPa to 3.04 MPa, a 0.8 % increase in density and a 7% increase in strength. In the following chapter an empirical relation is established to relate compressive strength with the applied compaction force and cement content. This relation would predict a 4.8 % increase in compressive strength for the increase in density seen with double-sided compaction, rather than the 7% actually found. Although the magnitude of the values predicted by this relation are only strictly valid for small cylindrical samples it is expected that the trends exhibited should be similar for standard-size blocks.

Table 4.9.2 The compressive strength and bulk ejection density resulting from single and double-sided compaction methods. Data given is for standard-size blocks which have been cut in half following 7-day damp curing.

Single-sided compaction	C1A	C1B	C2A	C2B	C4A	C4B	AVG C
Bulk density on ejection /kg/m ³	2086		2085		2087		2086
7-day wet compressive strength /MPa	2.70	2.90	2.87	2.85	2.81	2.90	2.84
Double-sided compaction	CD2A	CD2B	CD3A	CD3B	CD4A	CD4B	AVG CD
Bulk density on ejection /kg/m ³	2098		2100		2111		2103
7-day wet compressive strength /MPa	3.01	3.08	2.89	3.08	3.08	3.13	3.05

This difference between the predicted and recorded values of compressive strength would appear to indicate that the strength increase seen in double-sided compaction is due to two separate factors. Double-sided compaction has increased the total density of the block, effectively reducing the significance of frictional wall shear by halving the distance through which the applied force must be transmitted. A simple total density increase of this size would be expected to produce a strength increase of 4-5% on the basis of the empirical relation. It is proposed that the additional 2-3 % compressive strength seen in practice is due to the more uniform density distribution obtained using double-sided compaction. It is likely that the base of a double-sided block experiences greater additional compaction than the top. The compressive strength of a block depends on that of its weakest section, hence by increasing the density of the base, the weakest section of a block, the overall compressive strength will be substantially increased. If two blocks of having the same mean density were produced one by single-sided compaction and one by double-sided compaction this would predict that the double-sided one would be stronger.

4.9.3 A COMPARISON OF THE INTERNAL DISTRIBUTION OF STRENGTH RESULTING FROM SINGLE AND DOUBLE-SIDED COMPACTION

To see if the internal strength distribution was affected by single or double-sided compaction, the fourth blocks of each cement-stabilised set were sectioned after seven days of wet curing. The blocks were cut in half and subsequently each half into 27 near cube specimens (See figure 4.9.3). Each cube was capped with dental paste and 6 mm fibre board and tested for compressive strength. As a result of the length of time taken in cutting, capping and testing these half blocks (1 day), each half of each block was treated as a separate sample. A full listing of the compressive strength values obtained is given in appendix G.

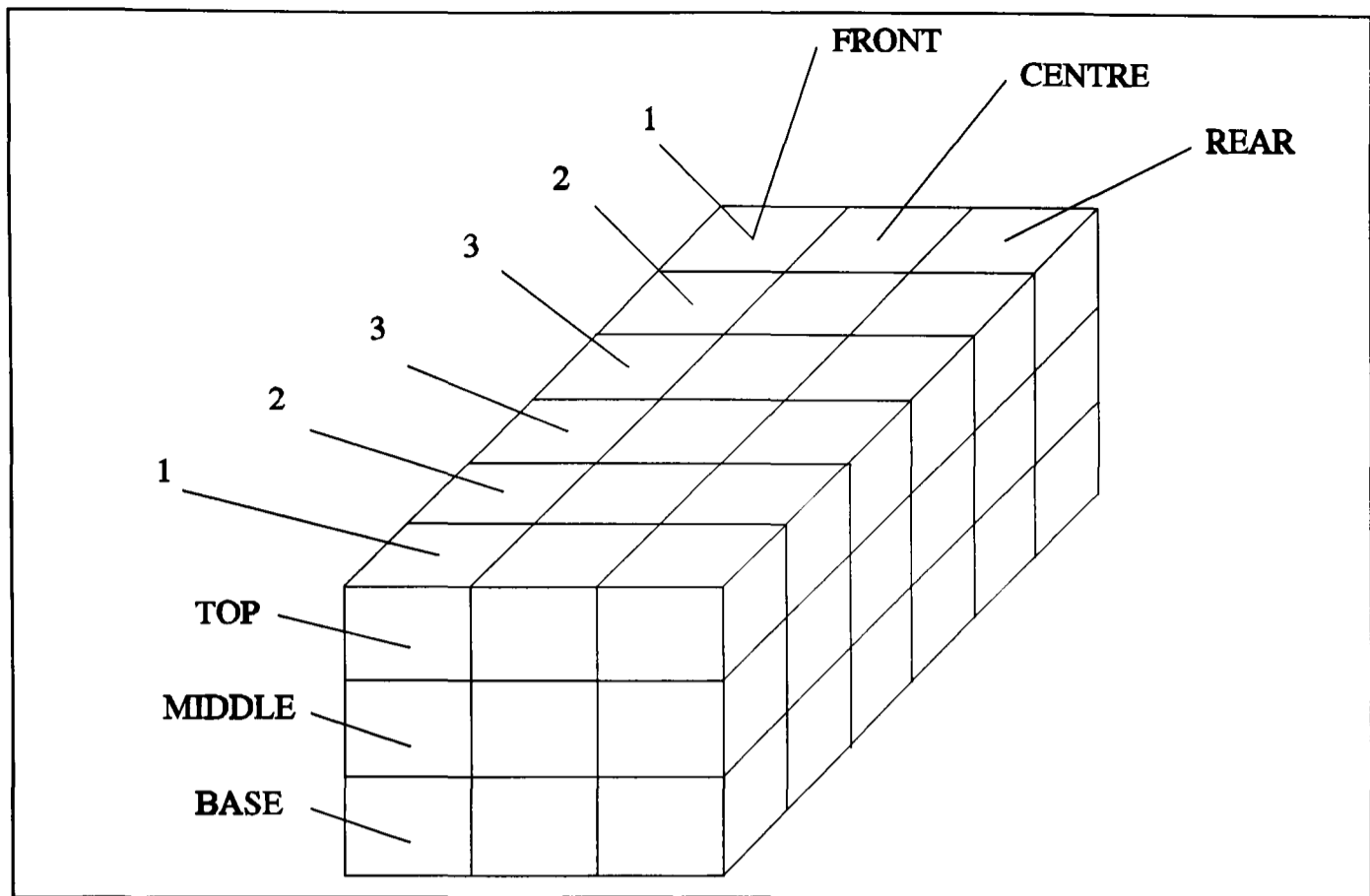

Figure 4.9.3 Schematic representation of the identification sequence used when sectioning the blocks.

The compressive strength data gathered from these block sections was analysed for any trend in strength distribution using a standard error of difference significance test. A significant difference between two samples was deemed to exist if the difference between the means of two samples was greater than 2 times the standard error of difference, this giving a 95% level of confidence.

Standard error = standard deviation ÷ square root of the sample size.

Standard error of difference = square root of the sum of the standard errors squared.

The data was correlated to determine whether double-sided compaction produced a more uniform vertical distribution of strength, whether there was any observable non uniform lateral strength distribution and whether there was any observable difference between surface and body sections.

The mean strength for all block sections was found to be 3.805 MPa (variance 0.030) for double sided compaction and 3.703 MPa (variance 0.213) for single sided compaction. These values are appreciably higher than those found for the unsectioned blocks. It is thought that the difference in specimen shape and size is largely responsible for this increase.

The surprisingly slight difference in compressive strength between the two methods is a result of inadequate soaking of one of the four block halves used for sectioning. One half (c3a) of the block compacted by single-sided compression was unfortunately not adequately soaked prior to compression testing: it was submerged for only 5 hours rather than 16 for the remaining block halves. This resulted in an overall increase in compressive strength for sections of this block half, the mean compressive strength of all sections of the inadequately soaked block being 4.07 MPa (variance 0.386) compared to a mean of 3.33 MPa (variance 0.174) for the adequately soaked half.

Direct comparison of overall block compressive strengths cannot be made from the sectioned data. However it would be expected that the relative internal strength distribution would be unaffected by an overall strength increase. Tables 4.9.3a and 4.9.3b give the result of the statistical analysis for single and double-sided compaction respectively. The average value for the compressive strength of each small section was found by combining the values found for each half. Significance was calculated to a 95% confidence level.

It can be seen from table 4.9.3a that there is a significant fall in block strength both between the top and base (15%) and between the middle and base (11%) but not between the top and middle. This is in broad agreement with the mould wall pressure recorded by the LVDT transducers, indicating a poor vertical distribution of compressive strength. It would then appear that a significant reduction in density occurs as distance from the moving compaction piston increases.

Table 4.9.3a Pattern of strength distribution for standard single-sided compaction, determined by direct compression testing of small block sections.

Areas compared	standard error of difference	difference between means	percentage change in compressive strength	significance to a 95% level of confidence
VERTICAL STRENGTH DISTRIBUTION				
Top/base layer	0.475	0.526	15	SIG
Top/middle layer	0.429	0.148	4	NON SIG
middle/base layer	0.309	0.378	11	SIG
HORIZONTAL STRENGTH DISTRIBUTION				
one/three	0.438	0.507	15	SIG
one/two	0.435	0.380	11	NON SIG
two/three	0.248	0.126	4	NON SIG
SURFACE/BODY STRENGTH				
1,2&3 external surfaces/no external surfaces	0.209	0.194	6	NON SIG
3 external surfaces/no external surfaces	0.867	0.516	15	NON SIG

Examination of the horizontal distribution of strength showed that a significant 15% difference in compressive strength was found between vertical sections 1 and 3 (the end and centre of the whole block, see figure 4.9). A large although not significant 11% difference was found between sections 1 and 2 and a small not significant 4% difference between sections 2 and 3. This indicates that strength may also depend on the proximity of a section to an external block surface, each specimen in section 1 having at least one external surface, while section 2 and 3 both contain a specimen with no external surfaces.

To investigate the effect of proximity to an external surface two further comparisons were made, one between all sections having at least one external surface and those which have no external surfaces and one between sections having three

external sections and those having no external sections. Although a 15% difference in strength was found between sections having three external surfaces (corner sections) and those having none (central body sections), the small number of samples and large variation between the samples indicates that this difference is not significant. The failure of this significance test would be expected on the basis of the vertical strength distribution, since two of the corner sections are from the top of the block while two are from the base. The quite large difference in these means (three external/no external) might indicate that external surfaces are stronger than central regions but a larger sample size would be required to statistically validate this finding. The smaller difference between the means for sections containing 1,2 or 3 external surfaces and that for sections containing none (6%) is similarly not statistically significant. This horizontal and surface data then indicates that the proximity to an external surface does affect the compressive strength but is not as prime a determinant of strength as vertical height.

In contrast Table 4.9.3b shows that there is no significant difference in compressive strength between the top and base (0.4%) of a block compacted by double-sided compaction but that there is a significant difference between the top and middle (4.3%) and a similar, though smaller, not significant difference between the middle and base (-3.8%). It should be noted that this latter difference only marginally fails the significance test. This is in broad agreement with the expectations of double-sided compaction, base strength is increased and the lowest strength is in the central region of the block. The smaller difference in strength between the middle and base compared to the top and middle would also be expected as the method of compaction was not "perfect" double-sided compaction; the base of the block experienced only 81% of the compaction force experienced by the top of the block.

Table 4.9.3b Pattern of strength distribution for double-sided compaction, determined by direct compression testing of small block sections.

Areas compared	standard error of difference	difference between means	percentage change in compressive strength	significance to a 95% level of confidence
VERTICAL STRENGTH DISTRIBUTION				
Top/base layer	0.178	0.015	0.4	NON SIG
Top/middle layer	0.142	0.160	4.3	SIG
middle/base layer	0.148	-0.145	-3.8	NON SIG
HORIZONTAL STRENGTH DISTRIBUTION				
one/three	0.162	0.163	4.3	SIG
one/two	0.170	0.167	4.5	NON SIG
two/three	0.087	-0.005	-0.1	NON SIG
SURFACE/BODY STRENGTH				
1,2&3 external surfaces/no external surfaces	0.082	0.076	2.0	NON SIG
3 external surfaces/no external surfaces	0.184	0.319	8.5	SIG

Examination of the horizontal strength distribution showed a similar trend to that found for single-sided compaction, namely that a significant (4.3%) difference existed between the end and central regions of the block (sections 1 and 3). It also showed that a similar, though not proven significant, difference (4.5%) existed between sections 1 and 2, while a negligible difference existed between sections 2 and 3 (0.1%). Again it should be noted that both of the differences between sections 1 and 3, and sections 1 and 2 are very close to the significance boundary.

When the surface data was examined, a significant (8.5%) difference was found between specimens having three external surfaces and those having none. However this would be expected from the vertical strength distribution as the specimens having

three external surfaces all lie either in the top or base regions of the block while those with no external surfaces lie in the central region of the block. When the difference between specimens having 1,2 or 3 external surfaces and those having no external surfaces was examined, only a small (2%) difference was found. The similarity of the horizontal and surface strength distributions with those for single-sided compaction would be expected, no change in lateral distribution of the applied compaction force had been made. Hence it would appear that although areas of the block nearest to an external surface will be stronger, this trend is out weighed by the vertical distance of a given area from the nearest moving piston.

In general the strength distribution was much more uniform for double-sided compaction, indicated specifically by the low variance of the samples, 0.030 for double-sided against 0.213 for single-sided compaction. This data has indicated that single-sided compaction does result in a vertical strength variation, a 15% loss in compressive strength is evident in the base region of the block, compared to the block top. Moreover it has been shown that pseudo double-sided compaction can increase the uniformity of strength, reducing the difference in strength between the top and bottom to approximately zero and the difference between the middle and top and base regions to approximately 4%.

The horizontal and surface/interior distributions indicate that quasi-static compaction does produce increased strength in regions closest to the mould walls. This is in agreement with the *Effective-Pressure Model* put forward earlier. The vertical distribution data indicates that friction is significant, as suggested by the *Frictional Poisson Flow Model*, and that the effect of friction may be reduced by the process of double-sided compaction. It has been shown that double-sided compaction improves both the total strength of the block and the uniformity of strength distribution.

CHAPTER 5

THE RELATION OF STRENGTH AND DURABILITY TO CEMENT CONTENT AND MOULDING PRESSURE

5.1 INTRODUCTION

By examining the relative influence of compaction pressure and cement content on strength, durability and susceptibility to poor curing of blocks produced by quasi-static compaction, this chapter extends the understanding of the benefits and drawbacks associated with high and low pressure compaction. The compaction pressure and the cement content used in the manufacture of stabilised soil blocks are prime determinants of the block's final cured strength and durability. For a given soil, compaction pressure and cement content may be traded against each other for a given final cured strength. It is known that block durability increases with increased strength. However it is not known whether it is the block strength, the block density (dependant on compaction pressure) or the cement content which is primarily responsible for this increase in durability. This chapter first sets out the research conducted to assess the relative influence of compaction pressure and cement content on cured strength and then goes on to examine durability issues. On the basis of the

investigation of cured strength an empirical relationship is derived which relates the wet compressive strength of well-cured samples to their compaction pressure and cement content. Although it is generally accepted that the performance of a block will be improved both by raising the compaction pressure and by increasing the stabiliser content, the relative effect of these two changes appears to be uncharted. For example, does a doubling of compaction pressure give the same improvement in strength as a doubling of cement content? Without this information any economic modelling of the relative cost of high and low pressure compaction is impossible.

Lunt of the UK Building Research Establishment (Lunt, 1980) conducted a series of tests on two Ghanaian soils (both with high fines content, 49.0 and 56.0%) to assess the effect of increased compaction pressure on the blocks' performance when stabilised with 6% lime by dry weight. He concluded that "Improved performance can be achieved by increasing the compaction pressure although the degree of improvement diminishes as this pressure is increased. It is suggested that presses operating in the range 8 to 16 MPa could give satisfactory and economical results". This work thus suggests that there may be some economic advantage in using a high pressure compaction machine. However, Lunt's research did not examine the effect of increased stabiliser content on strength. Using the empirical relationship between strength, compaction pressure and cement content derived for *soil-A*, a simple economic model is constructed to assess whether higher compaction or increased cement is likely to be the more cost efficient method of increasing well-cured strength.

At present building regulations concerning soil-cement are still in their infancy. However those that exist usually cite a wet compressive strength standard for the blocks (typically 1.0 - 1.4 MPa, or 2.8 MPa). Such standards have been chosen because a compressive strength test may be conducted in a few minutes while a quick predictive durability test has not yet been developed. Any quick durability tests are relative measures which can determine which of two blocks is likely to be more

durable but cannot predict the actual effect of long term exposure to the elements. The only way of assessing the latter is to expose a test wall to the natural weathering elements in the proposed area of use.

Given that long term durability testing is unlikely to become part of the standard testing procedure it would be helpful to broadly know how durability is related to compressive strength and in particular whether durability is solely determined by a block's compressive strength or whether the relative balance of compaction pressure and cement content are also important. Will a block compacted at 2 MPa with a high cement content be significantly more or less durable than a block compacted at 10 MPa with a low cement content, having the same wet compressive strength and soil composition?

A further factor related to the pressure-cement balance is the effect of poor curing. It is always recommended that freshly ejected blocks are kept shaded and wet for *at least* four days to allow the majority of cement hydration reaction to occur. In practice this frequently does not occur and blocks are left to "dry out" in the same way as simple adobe. It would be expected that blocks of differing density, produced by different compaction pressures, would have differing permeability and hence lose water at different rates. As blocks produced by high pressure compaction require a lower cement content for a given strength than those produced by low pressure compaction, it may also be expected that the reduced permeability of the former coupled with their lower water demand (to hydrate the reduced quantity of cement) would cause a lesser loss in strength on poor curing than for low pressure blocks.

If the blocks are left to dry out it is the block surface which loses water first and hence this may result in a greater loss of strength in the surface than in the bulk of the block. Given that it is the surface of the block which is exposed to the weathering elements, it is this which will govern block durability and consequently building life. Any significant reduction in the ratio of surface strength to bulk strength

evident on poor curing would suggest that a compressive strength standard alone is not a good predictor of block durability. Again it would be of interest to establish whether any such change in the surface to bulk strength ratio is reduced by using higher compaction pressure.

5.2 EXPERIMENTAL INVESTIGATION OF THE RELATION OF STRENGTH TO CEMENT CONTENT AND MOULDING PRESSURE

A number of soil-cement cylinders were produced for a range of compaction pressures from 1 to 10 MPa and a range of cement contents from 3% to 11%. For each combination of pressure and cement three cylinders were produced, the average value of the wet compressive (seven day) strength was used in subsequent comparisons. The *soil-A* used is described in *appendix A*. This soil was selected as one which should be suitable for stabilisation based on previous authors' reports (United Nations, 1964). Although the numerical values given below are unlikely to be correct for other soil types, it is expected that the trends exhibited will be, provided that the other soils fall within the range of suitable soils as defined in chapter 3.

The mould used was that specified in BS1924 (British Standards Institution, 1975). A constant water content of 8% was used throughout the set of experiments¹. The mould was filled with a constant mass ($\pm 0.2\%$) of stabilised mixture regardless of the cement content. The cylinders produced were between 110mm and 125mm high, depending on the compaction pressure used, each having a nominal diameter of 50mm. The compacted green cylinders were sealed inside plastic bags in batches of

¹ The optimum water content at the time of compaction should strictly have been found for each compaction pressure and cement content. However the *soil-A* used has a low sensitivity to moisture content and the effect on the experimental data of holding water content constant should be minimal.

three, with a wet tissue to provide a damp atmosphere. They were then left to cure for seven days before complete immersion in water for 16 hours prior to wet compressive strength testing. *Appendix H* contains the full experimental data.

The results of the testing showed that both an increase in cement and an increase in compaction pressure increases the seven-day wet strength, however the relative influence of each is different. Figure 5.3a and 5.4a respectively show the rate of gain in strength when either cement or compaction pressure is held constant and the other is increased. On each graph the data points connected by dashed lines are the average of three experimental results. The error bars associated with the data points represent a statistical confidence level of 95%, the length of the bars giving an indication of the scatter in results.

In order to relate cement percentage and compaction pressure, the raw experimental data (compaction pressure, cement percent and cured strength) was used as the input for a PC-based modelling package SPSS. A number of models were tried of which a natural log against natural log type plot was found to be the best. The solid lines on the figures given below represent the best fit to the data generated by SPSS;

$$\ln(\text{str}) = (0.315 \times \ln(\text{pr})) + (1.216 \times \ln(\text{cem})) - 2.178$$

Where; str = compressive strength in MPa

 pr = compaction pressure in MPa

 cem = cement content percentage.

This model gave an adjusted R square measure of fit of 98.2% (Multiple R 99.1%)

5.3 THE EFFECT OF COMPACTION PRESSURE AND ENERGY ON SEVEN-DAY WET COMPRESSIVE STRENGTH

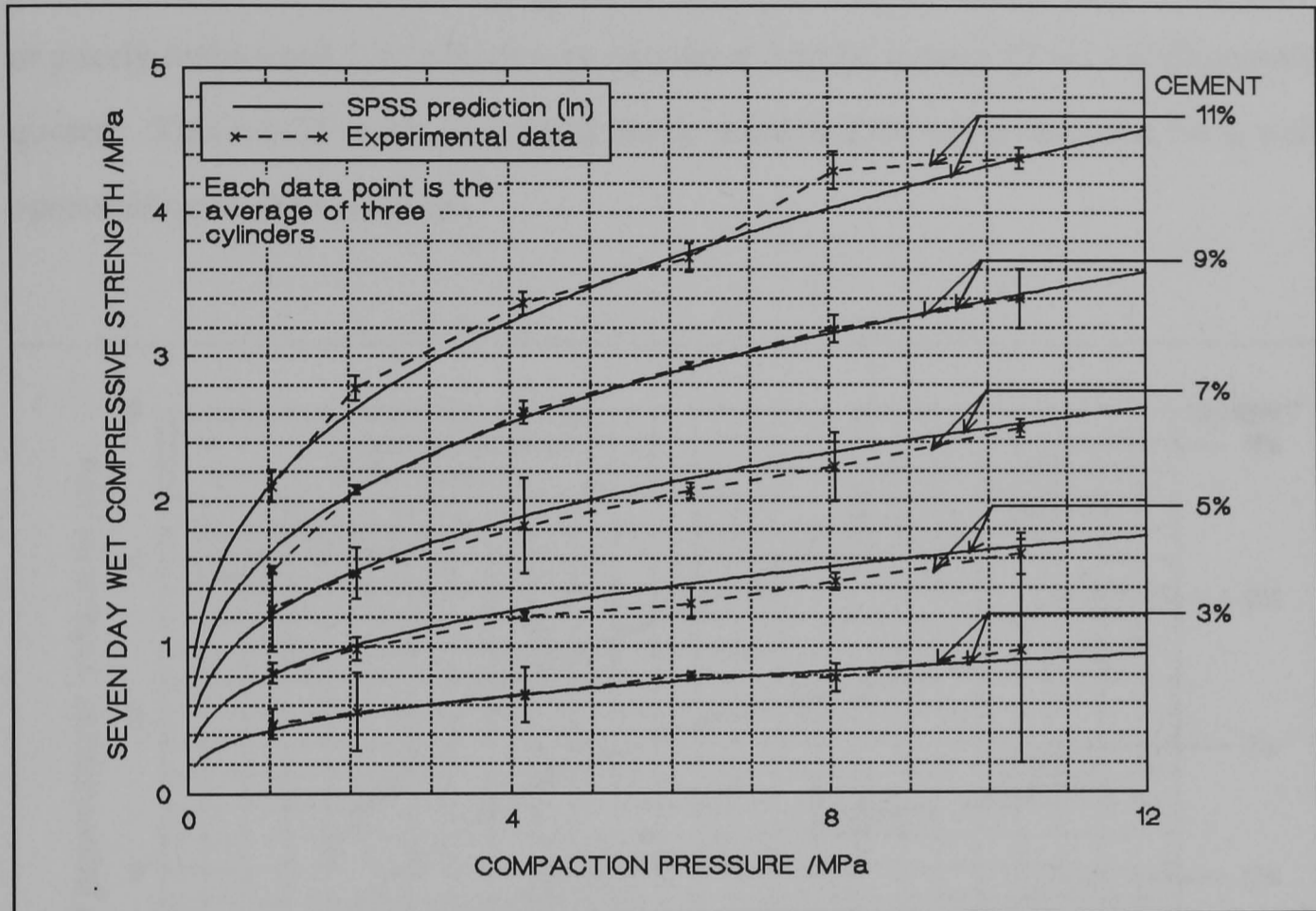

Figure 5.3a The effect of increasing compaction pressure on seven-day wet compressive strength. The error bars represent a 95% confidence level in the experimental data.

For a given cement content (Fig 5.3a) strength increases with increased compaction pressure. Below 2 MPa the increase is rapid while above this the rate of increase reduces, tending towards a limit strength, in agreement with Lunt (1980). The top band of Table 5.5 (section 5.5) shows the effect of doubling compaction pressure on the wet compressive strength. The figure given is the fractional increase in wet compressive strength resulting from doubling the respective variable. It can be seen that although the absolute gain in strength is higher for high cement contents, the fractional increase in strength is fairly constant. A doubling of compaction

pressure results in roughly 23% increase in wet compressive strength throughout the range.

Figure 5.3a shows that a modest change in the compaction pressure of low pressure machines will have a large effect on the cured strength. A poorly operated or poorly maintained Cinva Ram may operate at 1 MPa, instead of the 2 MPa usually quoted. This would result in a cured block strength 25% lower than that for a well operated/maintained machine.

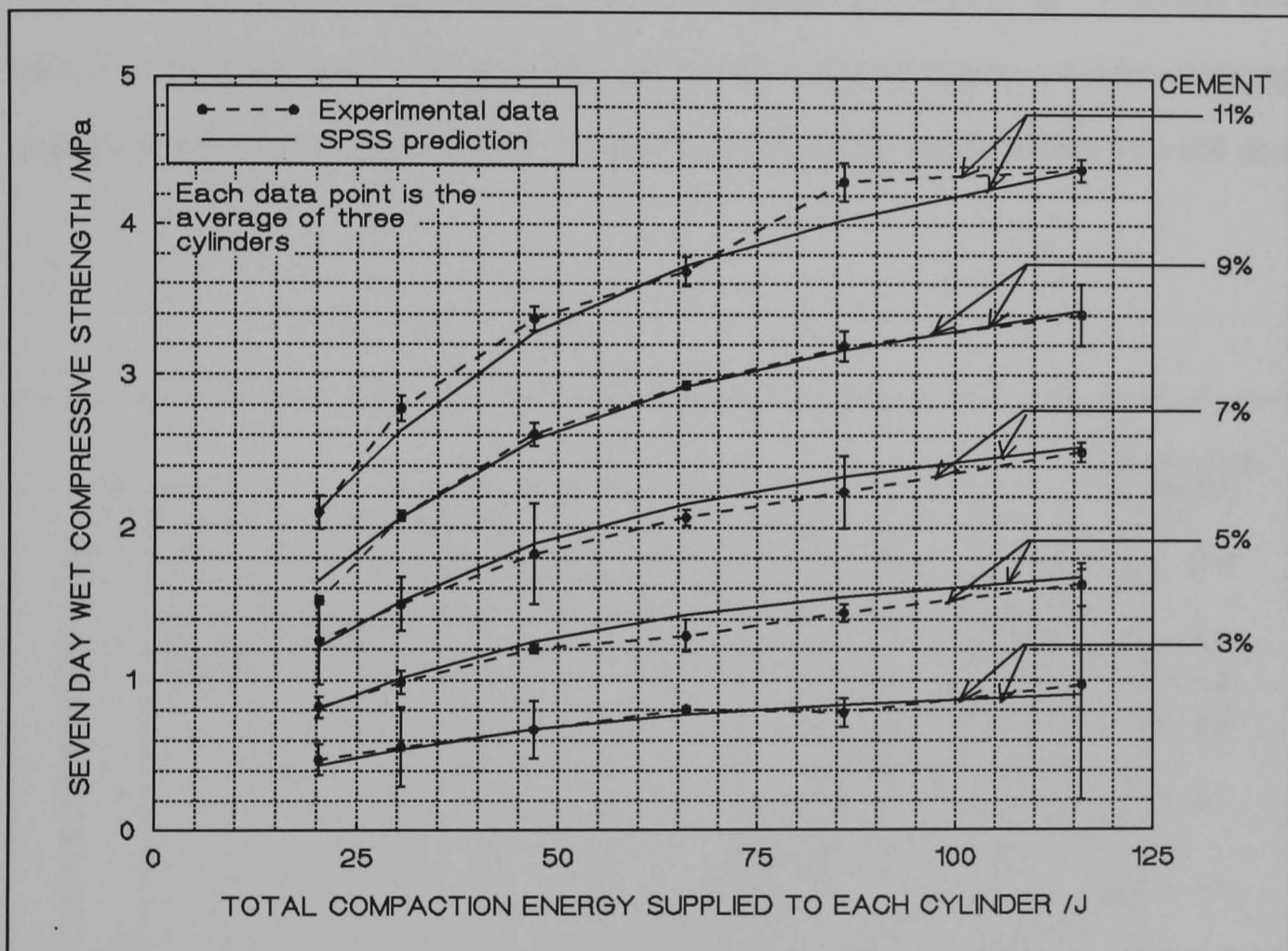

Figure 5.3b The effect of compaction energy on seven-day wet compressive strength. The error bars represent a 95% level of confidence in the experimental data.

Figure 5.3b is similar to 5.3a but shows the compaction process in terms of the energy expended in compacting the samples. If the 3% cement trace is examined then it can be seen that by doubling the compaction energy from 25 to 50J the compressive strength increases by 37%, but redoubling the energy from 50J to 100J only increases

it by a further 22.9%. This is consistent with the results shown in figure 5.3a as the energy required to increase the compaction pressure by one unit is greater at higher pressures than at lower ones and hence the diminishing return.

5.4 THE EFFECT OF CEMENT CONTENT ON SEVEN-DAY WET COMPRESSIVE STRENGTH

If figure 5.4 is examined it can be seen that for a given pressure the rate of increase in absolute strength increases with increasing cement content. However, (see table 5.5) the fractional increase in strength remains approximately constant, reducing slightly at higher cement contents. A doubling of cement content from 3 to 6% at a

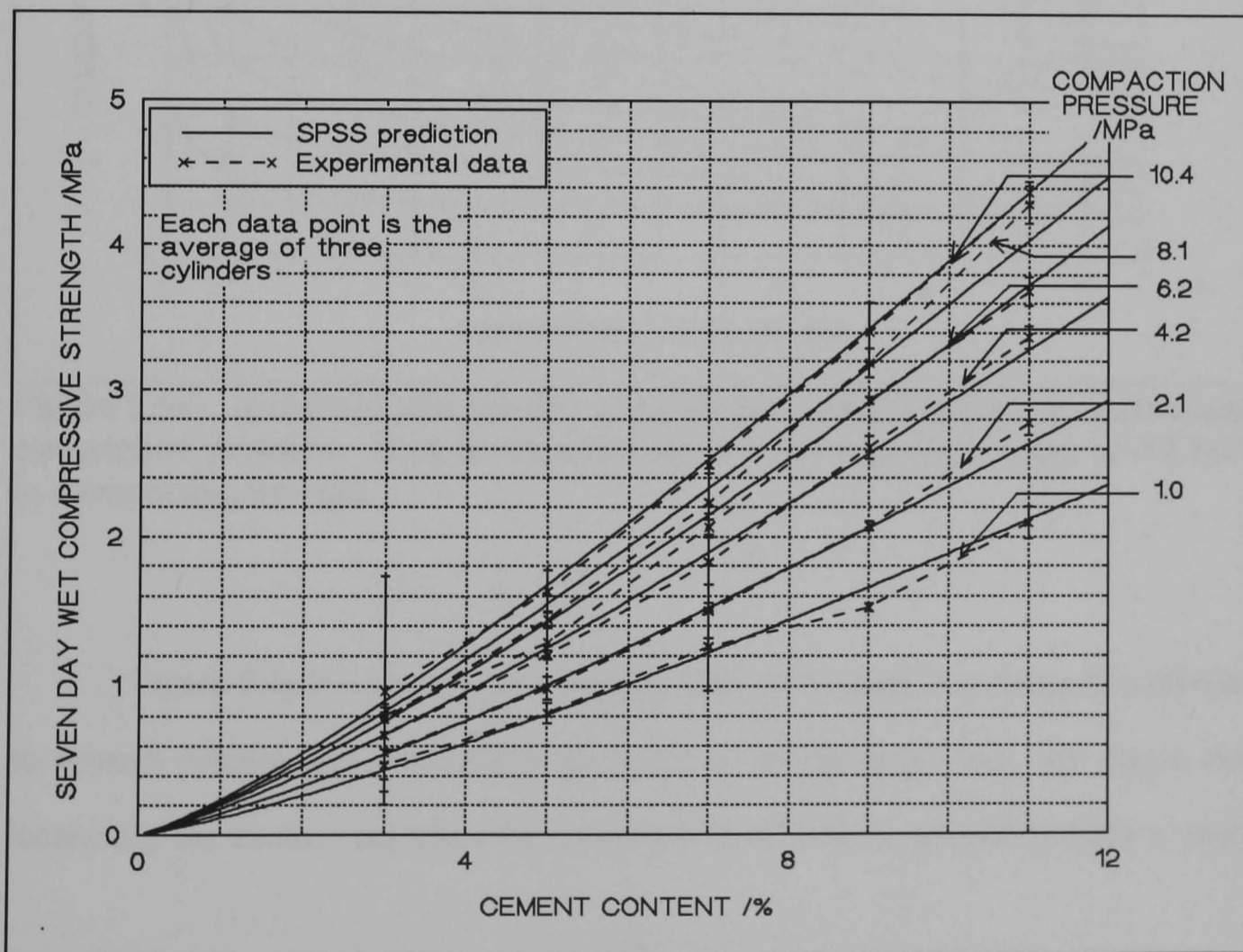

Figure 5.4 The effect of cement content on seven-day wet compressive strength. The error bars represent a 95% confidence level for the experimental data.

compaction pressure of 1.0 MPa produces a strength increase of 140% while a further doubling of cement from 6 to 12²% produces an increase of 133%.

5.5 THE PRESSURE-CEMENT-STRENGTH RELATIONSHIP

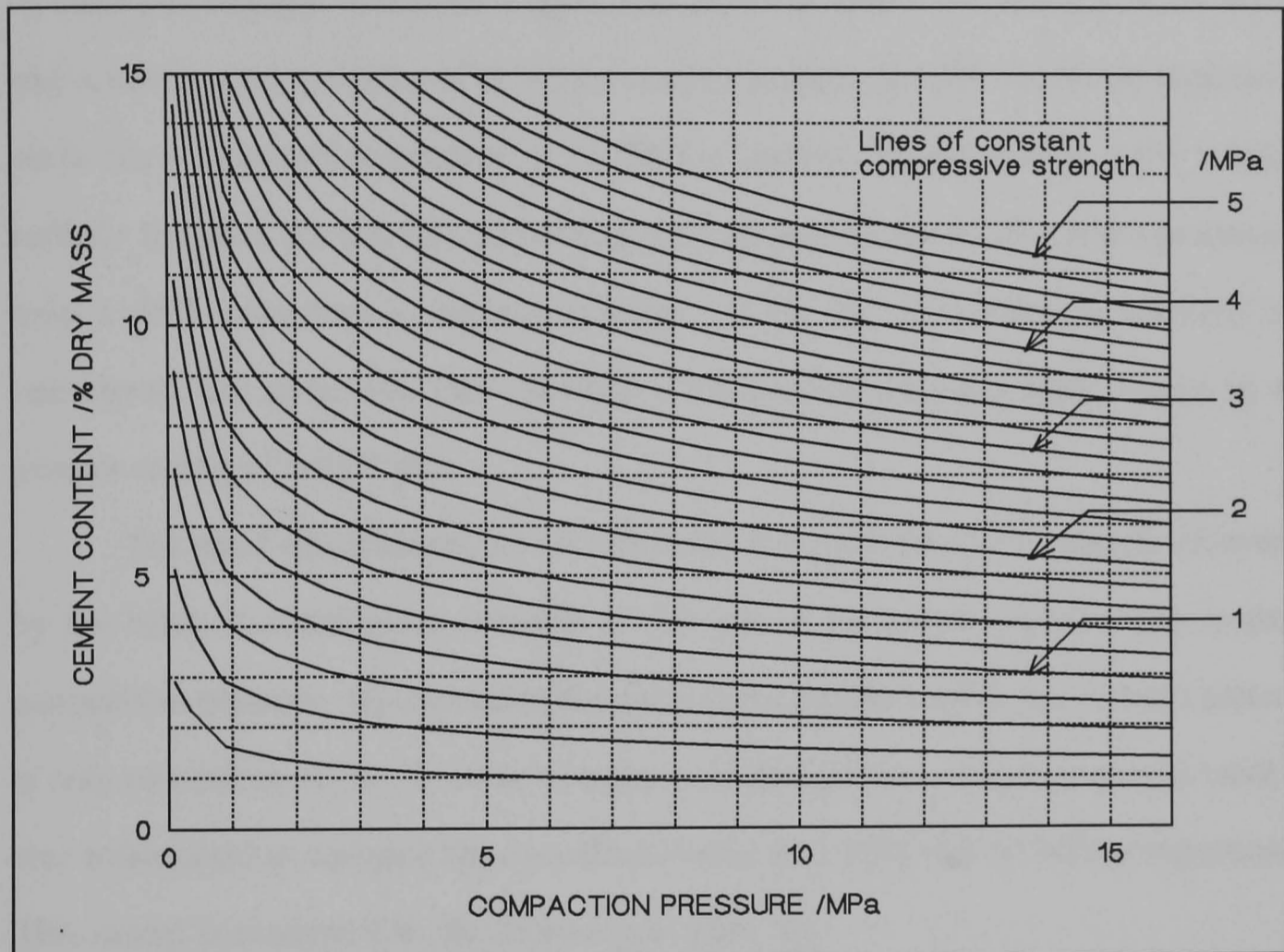

Figure 5.5a A contour plot relating compressive strength to cement content and compaction pressure. Each intermediate contour line represents a step of 0.2 MPa in compressive strength.

Figure 5.5a is a contour plot showing lines of constant wet strength in relation to cement content and compaction pressure. It can be seen from this figure that increasing the cement content of a stabilised block will in general provide a more

² The values for 6 and 12% cement content used here are based on the SPSS model rather than actual experimental readings.

effective method of increasing strength than increasing compaction pressure. Two standard wet strength values are normally quoted, either 1.4 MPa (Fitzmaurice 1958) or 2.8 MPa (Webb 1988)³. The relative effect of cement and compaction pressure may be examined by regarding the reduction in cement content required when changing production from a 2 MPa compaction machine to a 10 MPa machine at each of these two strength standards. Figure 5.5a shows that for a wet strength of 1.4 MPa and a compaction pressure of 2 MPa a cement content of 6.6% would be required, while for a compaction pressure of 10 MPa a cement content of only 4.3% would suffice. In effect, for this soil, increasing the compaction pressure five times produces only a 35% reduction in cement demand. If the 2.8 MPa strength standard is considered, the same five fold increase in compaction pressure again results in a cement saving of only 35%.

The trend which emerges from this study is that the final wet strength achieved by the block is much more sensitive to changes in the cement content than in the compaction pressure. By increasing the compaction pressure 400% the cement content is only reduced by 35 %. In order to interpret these figures, a simple economic model was constructed to compare the cost effectiveness of 2 MPa and 10 MPa compaction. This model is presented in the following section, 5.6.

³ Strength standards for soil-cement blocks are now becoming more widespread and vary from country to country to reflect differing climates and building techniques.

Table 5.5 The relative effects of pressure, energy and cement on compressive strength.

Doubled Parameter	Strength Increase	Strength Increase
Compaction Pressure Doubled (11%cem) (3%cem)	(Compaction 2 → 4 MPa) 2.59 → 3.23 MPa + 24.7%	(Compaction 4 → 8 MPa) 3.23 → 4.03 MPa + 24.7%
	0.54 → 0.67 MPa + 24.1%	0.67 → 0.82 MPa + 22.4%
Compaction Energy Doubled (11%cem) (3%cem)	(Energy 25 → 50 J) 2.38 → 3.35 MPa + 40.7%	(Energy 50 → 100 J) 3.35 → 4.20 MPa + 25.0%
	0.49 → 0.70 MPa + 37.0%	0.70 → 0.86 MPa + 22.9%
Cement Content Doubled (10.4MPa) (1.0MPa)	(Cement 3 → 6 %) 0.90 → 2.10 MPa + 133.3%	(Cement 6 → 12 %) 2.10 → 4.89 MPa + 132.9%
	0.42 → 1.01 MPa + 140.5%	1.01 → 2.35 MPa + 132.7%

The relation between seven-day wet compressive strength and compacted bulk density on ejection from the mould may also be found from this set of experiments. Figure 5.5b shows that, for a given cement content and curing regime, strength increases linearly with density. A 2.5% increase in density from 2000 kg/m³ results in an 18.6 and 21.6 % increase in strength for 11 and 3 % cement contents respectively. This shows that a given increase in density will result in a marginally greater increase in strength for low cement contents.

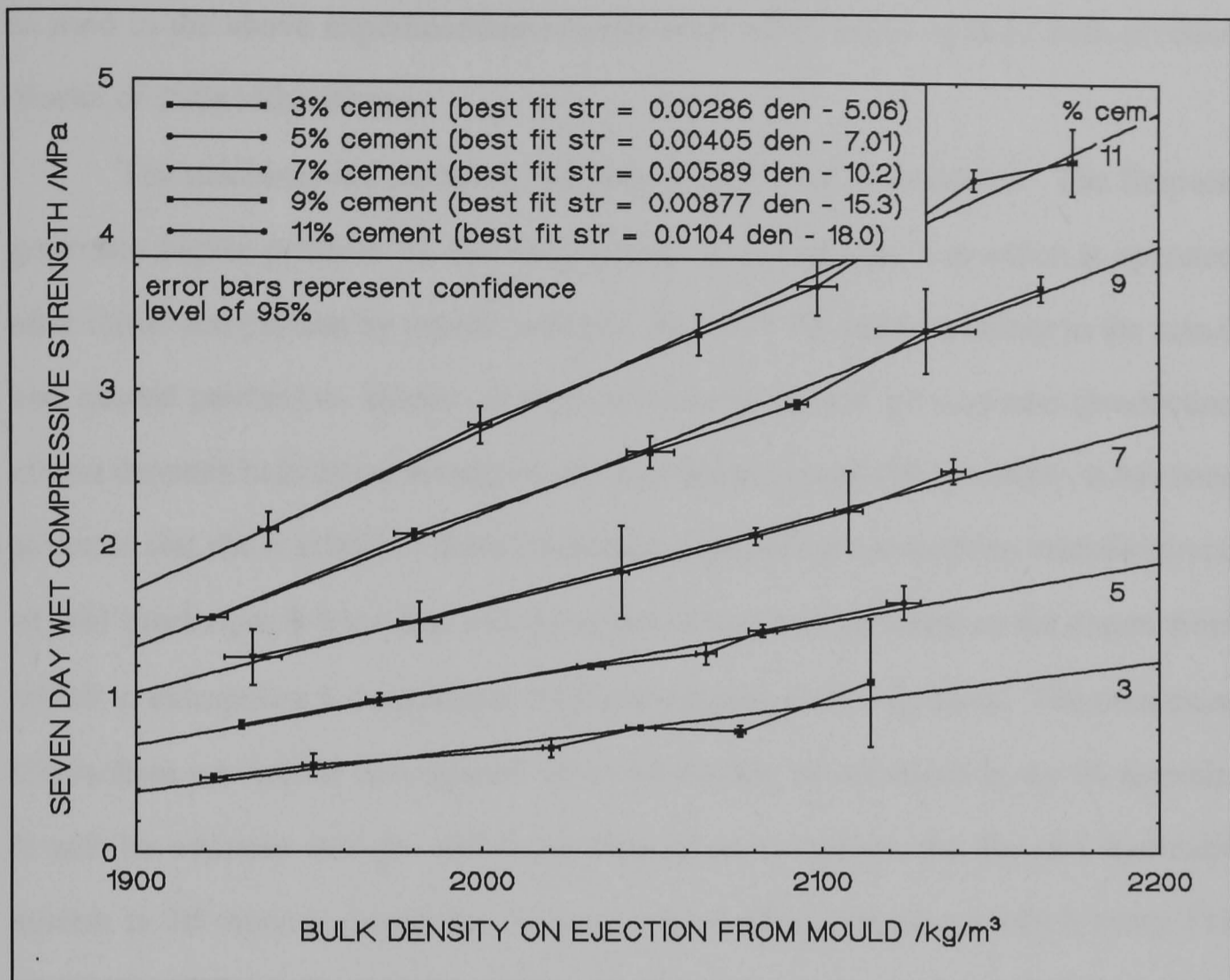

Figure 5.5b The relation of compacted bulk density to seven-day compressive strength, when the cement content is kept constant.

5.6 A SIMPLE ECONOMIC COMPARISON BETWEEN MACHINES GIVING RESPECTIVELY 2 AND 10 MPa COMPACTION

The following model uses the Cinva Ram and the Brepack machines for comparison, these compact to 2 and 10 MPa respectively. Two comparisons are initially made, one for blocks of 1.4 MPa wet compressive strength and one for blocks of 2.8 MPa wet compressive strength.

It is assumed that both machines are operating in the same country with the same cost for cement and labour; £3.00 per 50 kg bag and £3.50 per man day (the costs quoted are those for Sri Lanka in 1993). Both machines use the same *soil-A*,

as used in the above experimentation, compacted at 8% water content, both produce blocks of 290x140x100mm.

The machines are manually operated toggle lever mechanisms. The Brepack generates higher pressure by the incorporation of a hydraulic ram which is operated after initial compaction by toggle lever has occurred. As large variations in the actual and quoted production outputs of each of these machines are common (production output depends heavily on the experience and dedication of the operators), it has been assumed that the maximum Cinva Ram output, quoted by the machine manufacturers, of 300 blocks per 8 hour day will be achieved and will be taken as the datum from which to extrapolate a comparable production figure for the Brepack. The maximum Cinva Ram production rate equates to the production of one block every 96 seconds. It will be assumed that the additional time taken to operate the Brepack hydraulic system is 20 seconds giving the Brepack a production rate of one block every 116 seconds or 248 blocks per 8 hour day.

The labour requirement for the Brepack may also be based on that for the Cinva Ram. The machines produce different numbers of blocks of different density; 300 blocks per day (see above) of 1980 kg/m³ for the Cinva and 248 blocks per day of 2130 kg/m³ for the Brepack. Hence the labour required, per day or per block, for soil winning and block compaction is different. If the labour distribution shown below is assumed for the Cinva Ram when producing blocks of 1.4 MPa wet compressive strength (requiring 2,084.4 kg of soil per 300 blocks) then soil winning/processing labour costs may be calculated per kg of soil required. Similarly the labour cost of compaction and stacking may be calculated per block, 16 man hours are required to compact 300 Cinva Ram blocks (a labour cost of £0.023 per block) while 16 man hours are required to produce 248 Brepack blocks (£0.028 per block).

- It is assumed that the soil used is free and the only cost is then the cost of winning which is included in the labour cost.
- It is assumed that the working life of a Cinva Ram is 3 years at full production resulting in 270,000 blocks when working for 6 days per week and 50 weeks per year. The life of the Brepack is also assumed to be 270,000 blocks.
- It is assumed that the initial capital will be recouped with 30% interest within the working life of the machine assuming a 60% utilisation i.e. in five years for the Cinva Ram and six years for the Brepack. This results in a discount factor of 2.436 for the Cinva Ram and 2.643 for the Brepack.

LABOUR COSTS

Labour per day for a Cinva Ram producing 300 blocks (1.4 MPa wet compressive strength) per 8 hour day

soil winning	2 men to dig the soil, spread it out for drying and crush/sieve the dried material.
soil preparation	1 man to mix the material and prepare batches for compaction.
block pressing	2 men to operate the machine and stack the green blocks for curing.

Assuming the above labour distribution for a Cinva Ram production unit then the cost of labour per kg of soil used may be found.

Soil required per block	6.948 kg
No of blocks produced per day	300
Total mass of soil required	2,084.4 kg

Labour cost per man per day	£3.50
Labour required to win/process soil	3 man days
Total soil winning labour cost	£10.50
Soil winning labour cost per kg	£0.0050
Labour cost for block pressing (Cinva Ram)	£0.0233 per block
Labour cost for block pressing (Brepack)	£0.0282 per block

CEMENT COST

Cement cost per 50kg bag	£3.000
Cement cost per kg	£0.060

CINVA RAM DATA (prices in Pounds Sterling 1993)

Purchase cost of machine	£382.88 (1988 cost reported by Webb (1988) inflated by 5% pa)
Total freshly demoulded weight of one block	8.0kg (demould density 1980 kg/m ³ , volume 290x140x100mm)

1.4 MPa wet compressive strength

Cement percentage required for 1.4 MPa wet strength (based on figure 6.5a)	6.6%
Mass of soil per block	6.948 kg
Mass of cement per block	0.459 kg
Mass of water per block	0.593 kg

2.8 MPa wet compressive strength

Cement percentage required for 2.8 MPa wet strength (based on figure 6.5a)	11.7%
Mass of soil per block	6.631 kg
Mass of cement per block	0.776 kg
Mass of water per block	0.593 kg

CINVA RAM COST ANALYSIS

1.4 MPa wet compressive strength

Cost of cement per block 0.459 kg cement per block @ £0.060 per kg	£0.0275
Cost of soil winning labour per block 6.948 kg soil per block @ £0.0050 per kg	£0.0347
Cost of soil pressing labour per block (for Cinva Ram)	£0.0233
Cost of machine depreciation per block $£(382.88 \div 2.436) \times 5 \div 270,000$	£0.0029
	<hr/>
Total cost per block	£0.0884

CINVA RAM COST ANALYSIS

2.8 Mpa wet compressive strength

Cost of cement per block 0.776 kg cement per block @ £0.060 per kg	£0.0466
Cost of soil winning labour per block 6.631 kg soil per block @ £0.0050 per kg	£0.0332
Cost of soil pressing labour per block (for Cinva Ram)	£0.0233
Cost of machine depreciation per block $£382.88 \div 2.436 \times 5 \div 270,000$	£0.0029
	<hr/>
Total cost per block	£0.1060

BREPACK DATA (prices in Pounds Sterling 1993)

Purchase cost of machine	£3828.80 (1988 cost reported by Webb (1988) inflated by 5% pa)
Total freshly demoulded weight of one block	8.65kg (demould density 2130 kg/m ³ , volume 290x140x100mm)

1.4 MPa wet compressive strength

Cement percentage required for 1.4 MPa wet strength	4.3%
Mass of soil	7.679 kg
Mass of cement	0.330 kg
Mass of water	0.640 kg

2.8 MPa wet compressive strength

Cement percentage required for 2.8 MPa wet strength	7.6%
Mass of soil	7.444 kg
Mass of cement	0.566 kg
Mass of water	0.640 kg

BREPACK COST ANALYSIS

1.4 MPa wet compressive strength

Cost of cement per block	
0.330 kg cement per block @ £0.060 per kg	£0.0198
Cost of soil winning labour per block	
7.679 kg soil per block @ £0.0050 per kg	£0.0384
Cost of soil pressing labour per block (for Brepack)	£0.0282
Cost of machine depreciation per block	
$£3828.80 \div 2.643 \times 6 \div 270,000$	£0.0322
Total cost per block	£0.1180

2.8 MPa wet compressive strength

Cost of cement per block 0.566 kg cement per block @ £0.060 per kg	£0.0340
Cost of soil winning labour per block 7.444 kg soil per block @ £0.0050 per kg	£0.0372
Cost of soil pressing labour per block (for Brepack)	£0.0282
Cost of machine depreciation per block $£3828.80 \div 2.643 \times 6 \div 270,000$	£0.0322
Total cost per block	£0.1316

Discussion

The data given above is summarised in table 5.6a below. It can be seen that for a final wet strength of 1.4 MPa and 2.8 MPa, high pressure compaction is 33.5% and 24.1% more expensive respectively. The above model assumes a 30% interest rate and hence penalises the Brepack as a result of its higher capital cost. However this high capital cost is not the only penalty. The Brepack compaction process takes longer than the Cinva Ram as an additional hydraulic circuit must be pressurised and hence the compaction cost in terms of operator labour is also higher as the productivity is reduced.

Table 5.6a Block production cost comparison (Sri Lanka)

Cost per Block	wet strength 1.4 MPa	wet strength 2.8 MPa
Cinva Ram 2 MPa compaction	£0.088	£0.106
Brepack 10 MPa compaction	£0.118 +33.5% over 2 MPa	£0.132 +24.1% over 2 MPa

Compaction at higher pressure produces denser blocks which use less cement but more soil. Hence the costs associated with the soil are increased. In the above

model it was assumed that the soil would be available free of charge except for the labour cost involved in winning it. If a secondary cost must be paid for the soil, land rental or a purchase price, then the high pressure compaction route is further disadvantaged.

Table 5.6b Percentage breakdown of block costs (Sri Lanka).

Cost Parameter	Cinva Ram 1.4 MPa strength	Brepack 1.4 MPa strength	Cinva Ram 2.8 MPa strength	Brepack 2.8 MPa strength
cement	31.1%	16.6%	44.0%	25.8%
soil winning labour	39.2%	32.4%	31.3%	28.3%
pressing labour	26.4%	23.8%	22.0%	21.4%
machine depreciation	3.3%	27.2%	2.7%	24.5%
total	100%	100%	100%	100%

Table 5.6b shows the percentage cost breakdown for the four blocks produced. It can be seen that although the high pressure compaction machine does reduce the cement demand, both the machine depreciation and the labour costs counteract this benefit. For these machines using this soil type, increasing the cement content appears to be more economic than increasing the compaction pressure. Even if the life of the high pressure machine is doubled high pressure compaction remains the more costly. However what is not clear from this analysis is the quality of the final blocks. Although both machines should produce blocks with the same wet compressive strength, their densities will be different. Ultimate bearing strength when wet is not the only valid measure of performance but the most expedient to test and numerically quantify. The blocks' durability may be different as a result of their differing density. This is examined from section 5.8 onwards.

The above analysis is only valid for the cement and labour rates quoted for Sri Lanka. In other areas the relative cost of cement and labour may be completely different. For example in rural Zimbabwe the cost of cement is increased to £3.50 per

50kg bag while the wage rate is reduced to £0.80 per man per day. The effect of this shown in tables 5.6c and 5.6d

Table 5.6c Block production cost comparison (rural Zimbabwe)

Cost per Block	wet strength 1.4 MPa	wet strength 2.8 MPa
Cinva Ram 2 MPa compaction	£0.0479	£0.0698
Brepack 10 MPa compaction	£0.0701 +46.3% over 2 MPa	£0.0864 +23.8% over 2 MPa

It can be seen that even for a rural environment, where the daily wage rate is much lower than the cost of a bag of cement, high pressure compaction remains the more expensive option. For this case it is primarily the machine depreciation cost which dominates the analysis as the labour costs are greatly reduced.

Table 5.6d Percentage breakdown of block costs (Zimbabwe)

Cost Parameter	Cinva Ram 1.4 MPa strength	Brepack 1.4 MPa strength	Cinva Ram 2.8 MPa strength	Brepack 2.8 MPa strength
cement	67.0%	32.9%	77.8%	45.9%
soil winning labour	15.8%	12.1%	10.4%	9.5%
pressing labour	11.1%	9.1%	7.6%	7.3%
machine depreciation	6.1%	45.9%	4.2%	37.3%
total	100%	100%	100%	100%

If the cement cost were increased to £6.00 per 50kg bag while the labour cost remained at the Sri Lankan value of £3.50 per man per day then the high pressure compaction route still remains the more expensive although the margin of difference is reduced (table 5.6e) to 18.8% and 8.5% for 1.4 MPa and 2.8 MPa strength standards respectively.

Table 5.6e Block production cost comparison (if £6.00 per 50 kg of cement in Sri Lanka)

Cost per Block	wet strength 1.4 MPa	wet strength 2.8 MPa
Cinva Ram 2 MPa compaction	£0.1160	£0.1525
Brepack 10 MPa compaction	£0.1378 +18.8% over 2 MPa	£0.1655 + 8.5% over 2 MPa

In most situations low pressure compaction will be more economic than high pressure compaction, provided that the block breakage rate is acceptably low, i.e. a moderate to high⁴ clay content soil is used (see section 5.7 below). If however the cost of high pressure machines can be significantly reduced, while keeping the production rate similar to that of the low pressure machines, then high pressure compaction may prove more economic. Moreover if high pressure compaction is found to increase block durability or reduce green block breakage rates, then a small cost premium may be acceptable.

The primary additional cost for high pressure compaction is the purchase cost of the compaction machine, the Brepack is ten times more expensive than the Cinva Ram. If high pressure compaction is to compete with low pressure compaction on a cost basis the price of the machinery must be reduced. In order to ascertain the purchase cost which would be required of a high pressure compaction machine for cost parity with a Cinva Ram the following analysis was conducted.

The purchase cost of a high pressure machine required for parity of block cost was calculated for each of the cases considered above. It was assumed that the soil processing, labour and cement costs associated with the Brepack block would apply to any machine compacting to an equivalent pressure. It has also been assumed that

⁴ Moderate and high clay contents within the acceptable clay content bounds of 10 - 30%.

the production rate and payback period would remain the same, any attempt to modify the production rate of a hypothetical machine is arbitrary. The capital cost required was calculated by assuming that the difference in block costs for any given case must be nullified solely by a reduction in the cost attributed to machine depreciation (calculated above at £0.0322 per block). The difference in block cost was deducted from the Brepack machine depreciation cost and a new machine depreciation cost per block found. Using this new depreciation figure the capital cost of the machine was found from the equation given below:

$$CC = ((DCB \times \text{No of blocks produced}) \div \text{payback period}) \times DF$$

where

CC = capital cost of machine

DCB = depreciation cost per block

DF = discount factor

The results of this analysis are presented in table 5.6f. This table shows that there is a wide variation in the parity cost required of a high pressure compaction machine which depends on the conditions used for the economic model, the purchase price varying between £262 and £2284, a nine fold variation. Where wage rates are higher than the cost of 50 kg bag of cement as is the case for the standard Sri Lankan model then the machine purchase price which would result in parity for high pressure compaction is unrealistically low. For the 1.4 MPa strength standard the high pressure machine would have to be £74 cheaper than a Cinva Ram! However when the price of cement is higher than the daily wage it would appear that a high pressure machine costing in the range of £1000 to £1500 would be able to produce blocks which were cost competitive with those produced by a Cinva Ram. Moreover if a high pressure machine were available at a cost of £1000-1500, then even in Sri Lanka the price

differential would be more than halved, reducing from 33.5% to 7-12%, for a 1.4 MPa strength and from 24.1% to 2-6% for a 2.8 MPa strength. Although it is unlikely that a traditional high pressure quasi-static machine could be produced for this price, it is possible that a dynamic-type machine could, since dynamic compaction does not require a costly hydraulic circuit or heavy duty bearings (see chapter 6).

Table 5.6f Capital cost required of a high pressure compaction machine for economic parity with low pressure compaction.

Economic model for which capital cost was calculated	Blocks manufactured to a 1.4 MPa strength standard	Blocks manufactured to a 2.8 MPa strength standard
Sri Lanka	£309	£737
Rural Zimbabwe	£1189	£1855
Modified Sri Lanka (cement cost £6.00 per 50 kg)	£1237	£2284

5.7 THE EFFECT OF COMPACTION PRESSURE ON GREEN BLOCK STRENGTH

The economic analysis above is not able to cover differences in production efficiency and adaptability or differentiate any superior block properties. Compaction to high pressure produces blocks which have a higher freshly demoulded (green) strength as a result of their higher density. This reduces the risk of block breakage during ejection and transportation to the curing area which has been reported by Lawson (1992) to be as high as 50% in extreme cases.

Moreover, because of the increased block density the range of soil which can be used for production is larger for the high pressure machines. Green strength depends on the soil particle grading and the block density. If the block density is

reduced then for the same green strength or handleability the soil's clay content must be increased. Thus high pressure compaction allows the use of soils with lower clay contents than those acceptable for low pressure compaction.

To determine the magnitude of the increase in green strength as a result of increased compaction pressure, two blocks were tested for compressive strength immediately on ejection from the mould, one having been compacted to 2 MPa and one to 9.7 MPa. The 2 MPa block failed at a load of 6.6 kN (pressure 0.16 MPa) while the 9.7 MPa block failed at a load of 15.3 kN (pressure of 0.38 MPa). For this soil (*soil-A*) high pressure compaction produced a green block which was 2.4 times as strong as low pressure compaction. This is a significant increase in green strength and would be expected to cut block breakage rates. Moreover the increased green strength would allow blocks produced by high pressure compaction to be stacked at least twice as high for curing. This would result in a significant saving in the area required for storing the blocks during curing and, because of the increased volume to surface area ratio of a larger stack, also reduce the rate of water loss. With a lower rate of water loss the curing process would be more efficient and the blocks would be less prone to dramatic strength loss as a result of "drying out" (see section 5.9).

5.8 THE RELATION OF BLOCK DURABILITY TO COMPACTION PRESSURE AND CEMENT CONTENT

The following section is based on the work of a third year engineering student (Sutcliff, 1994) who was advised by the author. For a final year undergraduate engineering project, Sutcliff examined the relationship between cement content, compaction pressure and durability for cylinders manufactured to three separate seven-day wet compressive strengths, 4, 2, and 1 MPa. For each strength three compaction pressures were used, 2, 6 and 10 MPa in conjunction with a suitable quantity of

cement, as determined from the empirical pressure-cement-strength relation given above (section 5.2). *Soil-A* and the BS1924 cylindrical mould were used to ensure compatibility with this relation.

Durability was determined on the basis of a water spray erosion test. Following seven days of damp curing the cylinders were dried out in an oven at 105°C. Each individual batch, containing five cylinders, was stacked in the rotating test rig and sprayed with water at a pressure of five bar from a distance of 40 mm for eight hours. The stack of cylinders rotated at 10.6 rpm and the spray rate was 14 litres per minute. After eight hours the cylinders were removed from the rig and re-dried in an oven at 105°C and the weight lost during the spray test recorded.

Unfortunately on completion of the experimental work it was found that the oven was too small to dry the samples completely and very spurious mass *gains* were recorded for the high strength cylinders. The wide variation of the results did not allow the formulation of an empirical relation by Sutcliff. He concluded that for a given strength no significant difference in durability resulted from different compaction pressure or cement contents. As the cylinders' compressive strength increased so did durability. An additional factor worth noting from Sutcliff's work is that tests involved both erosion by direct spraying and erosion by the subsequent flow of water down the sample surfaces. Weight comparison of the samples at the top of a stack of 5, suffering little run-off, and samples at the bottom of the stack, suffering maximum run-off, indicated that a substantial fraction of the erosion is attributable to run-off rather than direct spray contact.

The author has subsequently re-analysed the data gathered by Sutcliff to produce the graphs shown below. The data was analysed upon the assumption that incomplete drying affected all blocks similarly, so that the weight difference between nearly dried blocks represents differences in the amount of soil removed by the spray erosion test. Although there is a wide spread in the recorded mass loss, when the

data was subjected to linear regression and a series of "best fit" lines calculated a consistent set of trends were found. The graphs use the raw mass loss figures recorded by Sutcliff, including the misleading mass gain figures and hence the durability scale rises from -8 to +3 grams.

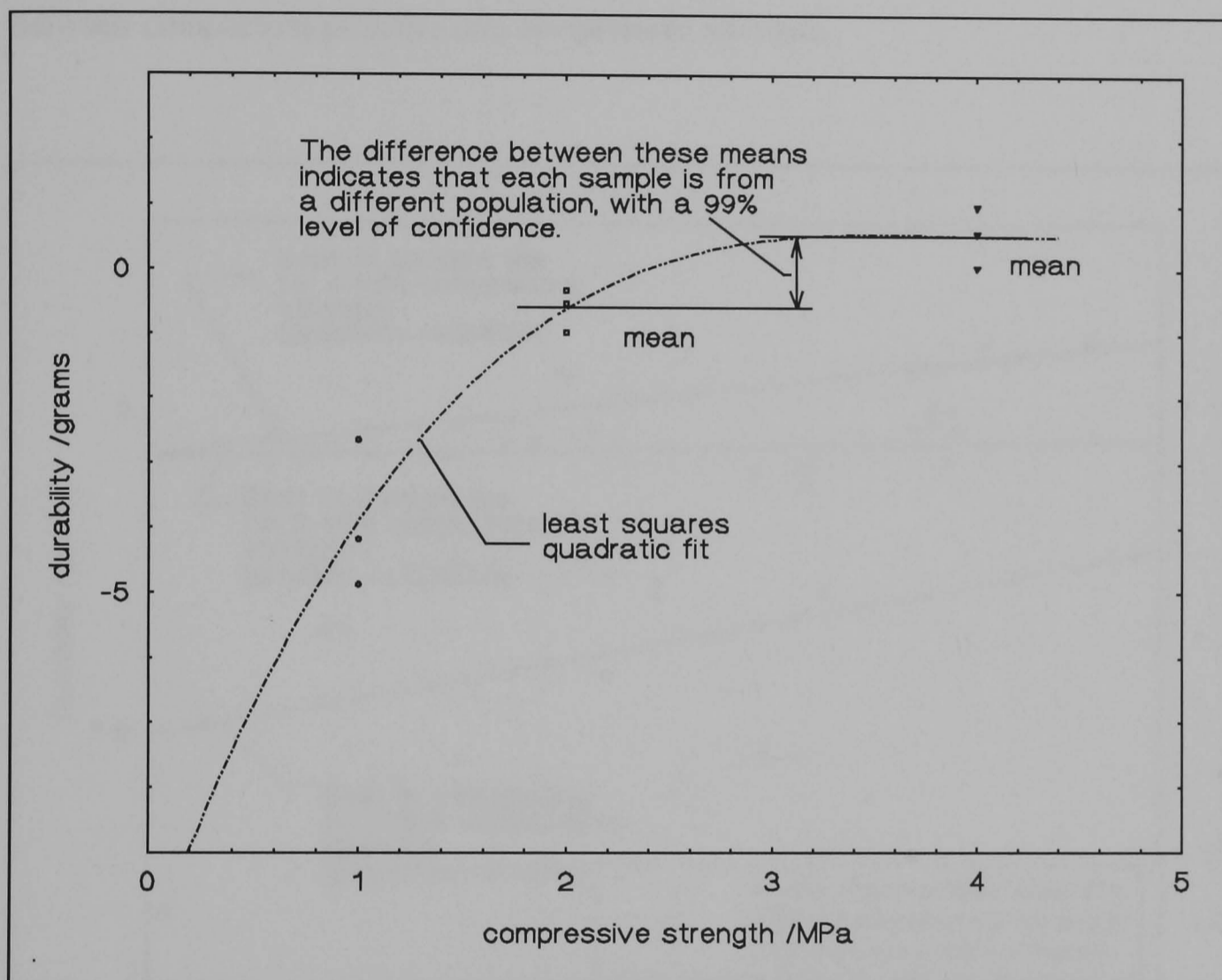

Figure 5.8a The correlation of durability with inferred compressive strength. Determined for small quasi-statically compressed cylinders. Each data point is the average of three experimental readings.

Figure 5.8a shows a plot of durability⁵ against compressive strength. It can be seen that durability shows a positive correlation with strength. Although the 2 and 4 MPa compressive strength data overlaps, the significant error difference method (see

⁵ Durability has been defined here as minus the weight loss per cylinder during spray testing. Thus ideal durability is represented by the value zero, poor durability by a value below about -2.

below section 5.9) determined that the difference between the two means was indicative of two separate samples, to a confidence of over 95%. This graph then suggests that compressive strength is a good indicator of block durability for blocks which have been identically cured. It would appear that a diminished increase in durability occurs on increasing compressive strength, similar to the relationship between compaction pressure and compressive strength.

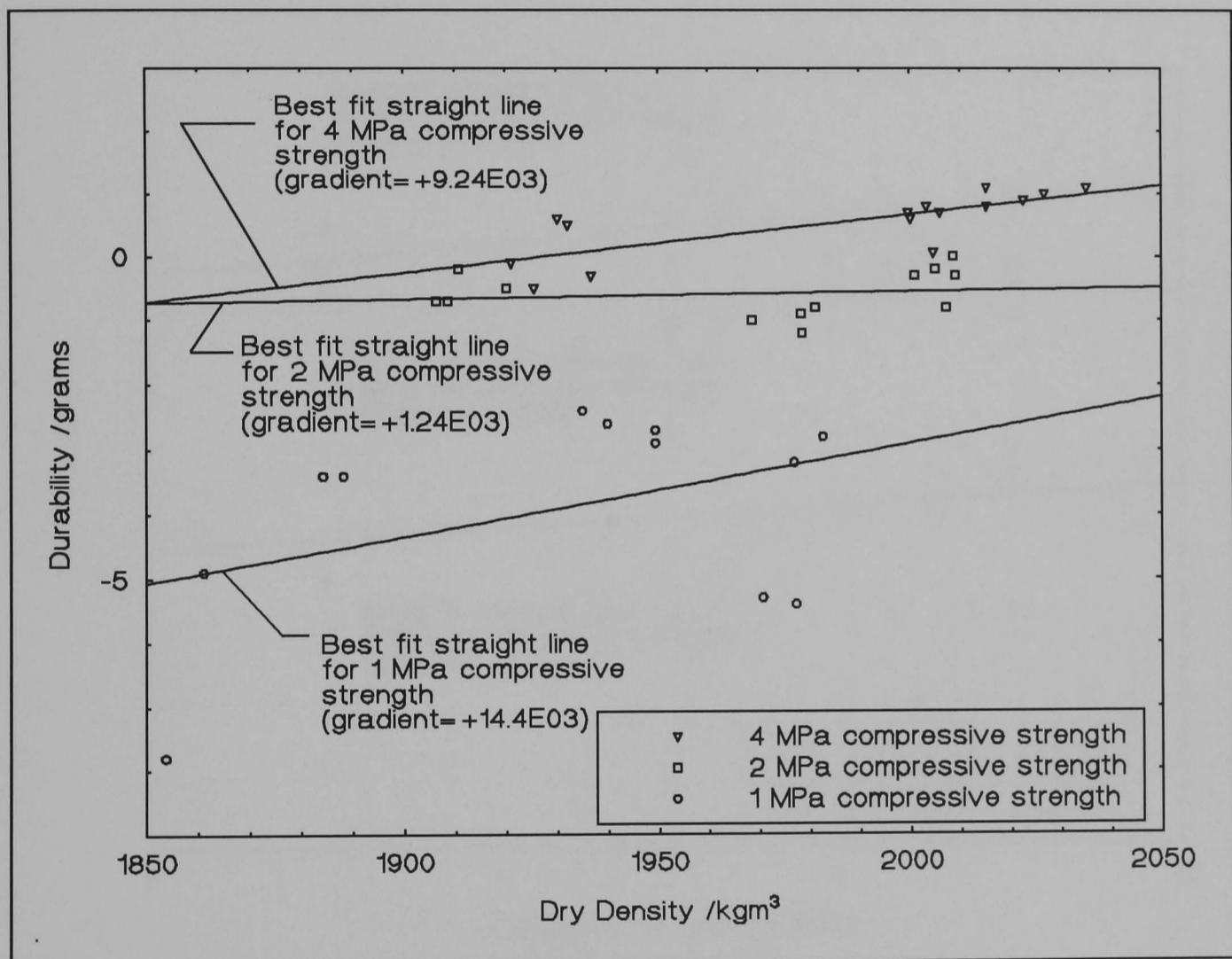

Figure 5.8b The correlation of durability with dry density. For small quasi-statically compressed cylinders. Each data point represents an experimental reading.

Figure 5.8b shows a plot of durability against dry density before erosion. Although large scatter is evident in Sutcliff's results, when the data for each separate compressive strength was linearly regressed a common trend appeared, namely that durability positively correlates with increased dry density. However regardless of dry

density, compressive strength appears to be a better indicator of durability (for equally well cured samples) than density. It can be seen that cylinders with 2 MPa compressive strength are universally more durable than those of 1 MPa strength despite a wide range in density. This trend is repeated between the 4 MPa and 2 MPa strength cylinders, although a degree of overlap is evident, it can be seen that this is small compared to the variation in dry density.

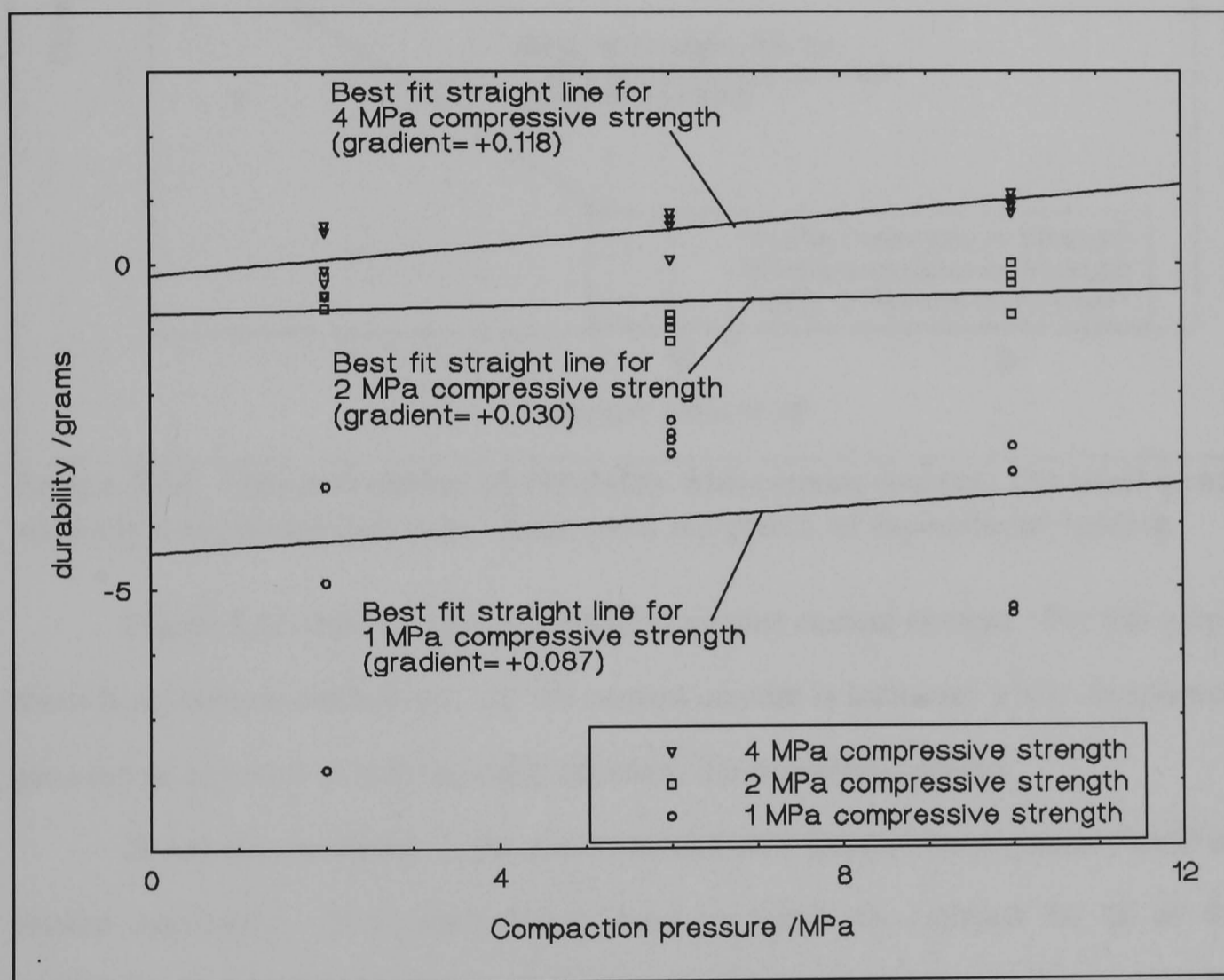

Figure 5.8c The correlation of durability with compaction pressure. For small quasi-statically compressed cylinders. Each data point represents an experimental reading.

Figure 5.8c shows a plot of durability against compaction pressure used to form the cylinders. This shows a positive correlation of durability with compaction pressure for each separate compressive strength. In this case compressive strength would again appear to be a better indicator of durability than the compaction pressure.

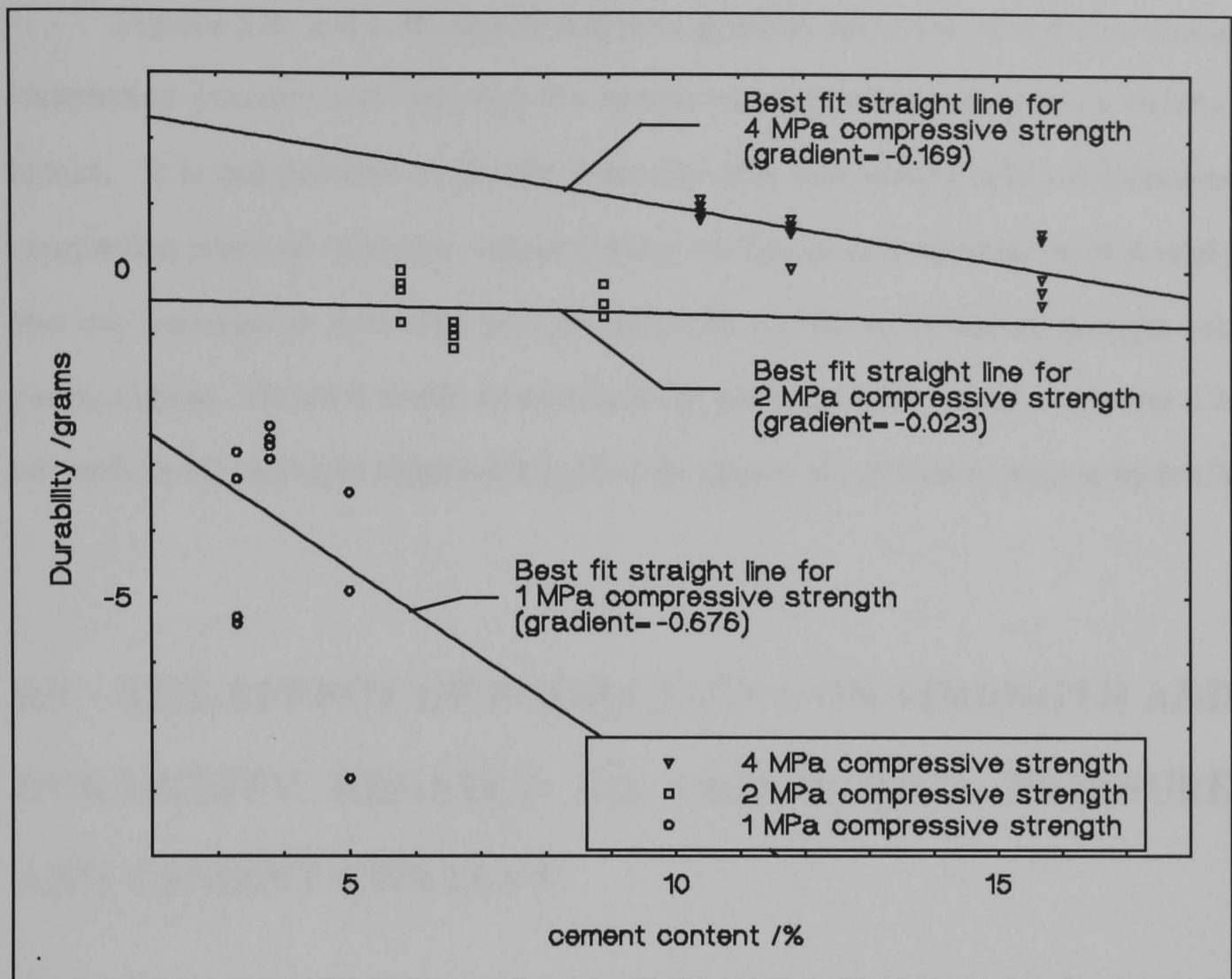

Figure 5.8d The correlation of durability with cement content. For small quasi-statically compressed cylinders. Each point represents an experimental reading.

Figure 5.8d shows a plot of durability against cement content. For this graph there is an inverse correlation. As the cement content is increased while compaction pressure is adjusted to hold strength constant, the durability reduces.

Given the variability in the results recorded by Sutcliff these graphs should be treated cautiously. The trends which have appeared are common for all of the different strength cylinder batches and hence should reflect a real trend, however the magnitude of such trends may not be estimated from these results. It would appear for a given curing regime and a given soil, compressive strength is a good indicator of durability. Spence (1975) has said that "*durability is strongly correlated with dry density*" This is supported by Sutcliff's results however it would appear that compressive strength shows a stronger correlation than dry density (figure 5.8b).

Figures 5.8c and 5.8d suggest that for a given compressive strength increasing compaction pressure and reducing the cement content will produce more durable blocks. It is not possible to exactly determine this relationship between increased compaction pressure - reduced cement content and increased durability, but it is likely that any variation in durability will be small for a given compressive strength and curing regime. Hence it would be assumed that although such a trend may exist it is not sufficiently strong to significantly affect the choice of production process by itself.

5.9 THE EFFECT OF POOR CURING ON STRENGTH AND DURABILITY RELATED TO COMPACTION PRESSURE AND CEMENT CONTENT

5.9.1 INTRODUCTION

As mentioned above (section 5.1) it would be expected that blocks of different density produced by different compaction pressures would have different permeability and consequently lose water at different rates if poorly cured. In an ideal situation this would not affect the final cured strength of the blocks as they would be stored in a shaded area, under sacking which would be kept permanently damp. However in practice soil-cement blocks are frequently poorly cured, a large number of field producers do not appreciate the need to keep the fresh blocks damp. Indeed this goes completely against the traditional adobe practice where block "curing" is a process of water loss (see chapter 2).

Correct curing of soil-cement entails additional cost to the operator, ideally a covered curing area is required to shade the blocks, sacking must be purchased, labour is required to maintain the sacking in a damp condition and in many areas the water

required is a scarce commodity. Moreover strength loss due to poor curing is only apparent when blocks are tested for compressive strength (which does not happen very often). Hence it is of interest to determine if increased density resulting from high pressure compaction would significantly reduce the rate of water loss such that, on poor curing, high pressure blocks would suffer a lower loss in strength than low pressure ones.

Coupled with the loss of compressive strength resulting from the loss of water from the main body of the block is the more localised but perhaps the more critical issue of water lost from the surface of the block. It is not known how the loss of water affects the surface properties of a block. It is the block surface which is primarily responsible for the block's durability. Inadequate curing allows the surface of the block to dry out long before all of the water has been lost from its body. Once the block surface has dried, water vapour continues to pass through on its way from the block body to the atmosphere. It is not clear whether the migration of this water vapour is sufficient to maintain an adequate moisture content for continued cement hydration. If cement hydration ceases once the block surface becomes dry then a dramatic reduction in surface strength may occur without a correspondingly large drop in block compressive strength. It has been said by Lea (1976) that during setting "The cement grains are acted upon by water to form a supersaturated solution from which the gel-like mass of crystals precipitates". This would suggest that water vapour alone would not be sufficient to allow normal cement curing to progress; once the surface areas of the block have dried out, the quantity of gel formed by the presence of water vapour rather than liquid is likely to be much lower.

If poor curing does have a pronounced effect in the surface region of the block then it follows that two blocks of equal cured strength, (one ideally cured, and one which should have been stronger but has been poorly cured) may have dramatically different durabilities.

5.9.2 EXPERIMENTAL INVESTIGATION OF THE EFFECT OF SIMULATED SOLAR CURING ON BLOCK COMPRESSIVE STRENGTH AND SURFACE SCRATCH RESISTANCE

To investigate the effects of poor curing, two sets of standard-size blocks were produced to nominally the same compressive strength (using the pressure-cement-strength relation derived empirically in section 5.2). One set used a compaction pressure of 2 MPa and one used a compaction pressure of 9.7 MPa. Once ejected from the mould two of each set were placed directly underneath a solar array (an artificial source of sunlight) while one was sealed inside a plastic bag with a wet tissue and left to cure in a separate laboratory (standard curing 20°C). No further water was added to any of the blocks. The blocks under the solar array were weighed repeatedly throughout a seven day curing period to assess the rate of water loss found with high and low pressure compaction (figure 5.9).

It is widely known that curing temperature affects the rate of strength gain for cement. In order to equate the two different curing temperatures a table of cement strength increase provided by Lea (1976) was assumed to be representative of the pattern of strength increase with temperature. The surface temperature of trial blocks placed under the solar array rose to between 35 and 45°C (45° for the exposed block top, 35° for the indirectly exposed block sides) while the laboratory used for standard curing maintained a temperature of 20°C. Using these temperatures to linearly interpolate the Lea data, 7-day solar curing should be broadly equivalent to 21-day standard curing in terms of strength gain. The prediction was somewhat complicated by the wide range in temperature of the solar cured blocks but was assumed sufficiently accurate for relative comparisons.

After seven days for the solar dried blocks and 21 days for the standard cure blocks, they were immersed in water until saturated and then subjected to a surface strength test based on a uniform-pressure scratch. Details of this apparatus are

included in appendix I. Three scratches were made on the top, bottom and longer sides of each block and the depth of the scratch squared taken as a representative relative measure of surface strength. The averaged results of the scratch test are presented in tables 5.9a and 5.9b (the raw results are presented in appendix J), the rows titled maximum and minimum depth give the maximum and minimum bounds for the average scratch depth squared based on two standard error⁶ divisions, a 95 % level of confidence. Following the scratch test each block was cut in half, capped with dental paste and 6mm fibre board prior to compressive strength testing. The results of the compressive strength testing are presented in table 5.9c.

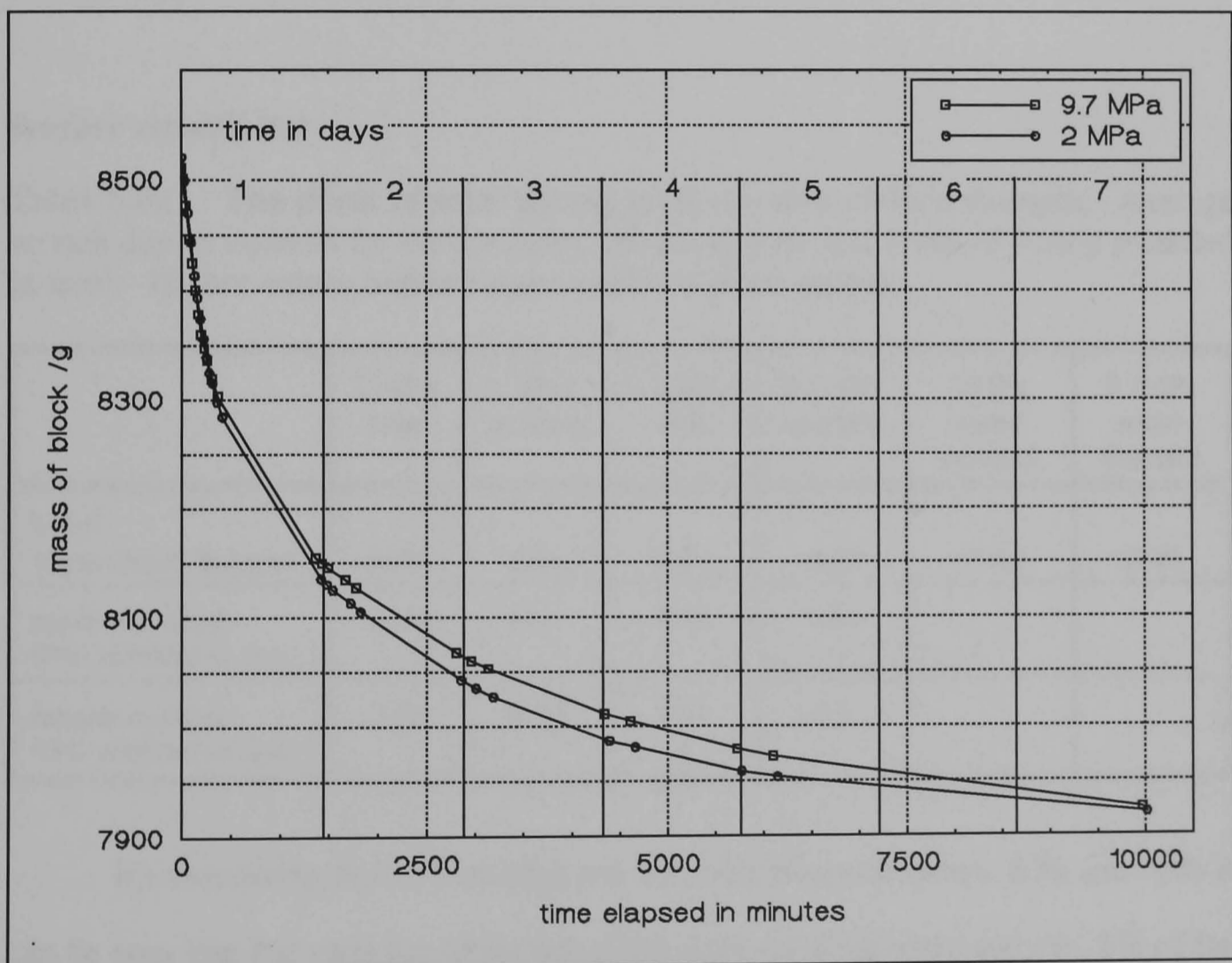

Figure 5.9 The effect of compaction pressure on water loss when subjected to simulated solar curing. For a standard-size block stabilised with 5%, compacted under standard (Chapter 4) conditions.

⁶ Standard error = standard deviation of the sample \div square root of the sample size. Minimum sample size for this table = 6.

5.9.3 EXAMINATION OF EXPERIMENTAL RESULTS

Rate of water loss on solar curing

It can be seen from figure 5.9 that the rate of water loss does not depend significantly on the compaction pressure used to form the blocks, both blocks lose water at approximately the same rate. As cement requires a certain minimum quantity of water to hydrate (25% by weight for complete hydration), this will result in the 2 MPa block, which contains more cement, reaching an inadequate water content marginally before the 9.7 MPa block. This would then predict that the 2 MPa block should display a marginally higher loss of compressive strength when subjected to solar curing.

Surface scratch test

Table 5.9a The effect of solar curing on block-side surface strength. Average scratch depths squared for blocks under simulated solar and standard curing recorded in mm². Higher values indicate more easily erodible surface.

	2 MPa solar	2 MPa standard	9.7 MPa solar	9.7 MPa standard	2MPa solar/ standard	9.7MPa solar/ standard
SIDE						
Mean Depth Squared	10.05	0.76	7.03	0.65	13.22	10.81
maximum depth 95% confidence level	11.92	0.97	8.02	0.81		
minimum depth 95% confidence level	8.33	0.57	6.11	0.51		

By examining the 95% confidence intervals shown in tables 5.9a and 5.9b it can be seen that the variation in scratch depth squared is approximately $\pm 25\%$ of the mean, in spite of this large variation significant⁷ differences can be observed.

⁷ Significance has been judged by the method of significant error difference whereby any difference between sample means which is greater than twice the size
(continued...)

In conventional use it is the sides (290x100mm) of the block which are exposed to the weathering elements and hence the most critical to a structure's durability. Normally the top and base of the blocks will be shielded by surrounding block courses.

If the block side data is examined it can be seen that the drop in scratch resistance on solar curing is pronounced, 1322 % and 1081 % respectively for low and high pressure compaction. When standard cured, the block side is always significantly more resistant to scratching than either the top or base. This is most probably due to the smoothing effect of "swipe" on compression and ejection. This swipe produces a surface which is visibly less granular than either the top or base. During compression the majority of material movement is in a vertical direction with only a small amount of lateral movement. This causes the soil closest to the mould-side wall to slide a greater distance over the mould-wall than that of either the top or base, on ejection this is even more pronounced as the block sides are subjected to a prolonged swipe as the block is pushed from the mould while the top and base plates are directly lifted away.

The visible reduction in side surface granularity is indicative of a reduction in side-wall porosity and an increase in the amount of fines present. The depth of influence of this swipe effect is likely to be very low, in the order of 1-2 mm. The increase in fines present in these surfaces is likely to be accompanied by an increase in the quantity of cement present. When standard-cured these slightly cement rich areas are allowed to develop "full" strength as water is adequately retained within the block. As a result the sides are more resistant to scratching than either the top or

⁷(...continued)

of the significant error difference is significant to a confidence level of 95%. (Significant error difference = square root of standard error of sample A squared plus the standard error of sample B squared).

base. On solar-curing the increased rate of water loss prevents these swipe areas from developing their potential strength and the actual side-wall strength drops to that of the unaffected subbase which is similar to that of the top and base.

By examining the data presented for the block tops in table 5.9b, it can be seen that solar curing significantly reduces the resistance of the blocks to scratching, the 9.7 MPa solar-cured block is twice as susceptible as the standard-cured block (solar-cured scratch depth squared \div standard-cure scratch depth squared = 2.0). Moreover if the 2 MPa solar-cured block top is compared with both the 9.7 MPa solar and standard-cure blocks it can be seen that it is respectively twice and nearly four times as susceptible.

A difference in the effect of solar curing on the top compared to the base surfaces is also evident. In general there is a greater drop in top scratch resistance than in the base resistance. This would be expected as it is the top of the block which is directly exposed to solar radiation and hence although it has a higher surface temperature, which could potentially increase the rate of strength gain⁸, it has a much higher rate of water loss than the base and hence this strength is not allowed to develop. The rate of water loss from the base is limited as it is in direct contact with its supporting board.

⁸ According to conventional concrete literature (Lea 1976) increasing the curing temperature beyond a certain point will reduce final cured strength. The critical temperature varies with the type of cement and the water/cement ratio.

Table 5.9b The effect of solar curing on surface strength for top and base block faces. Average scratch depths squared for blocks under simulated solar and standard curing recorded in mm².

Scratch Location	2 MPa solar	2 MPa standard	9.7 MPa solar	9.7 MPa standard	9.7MPa solar/standard
TOP					
Mean Depth Squared	10.10	N/C	5.80	2.89	2.00
maximum depth 95% confidence level	13.45	N/C	6.79	3.29	
minimum depth 95% confidence level	7.23	N/C	4.89	2.51	
BASE					
Mean Depth Squared	4.36	N/C	4.04	2.79	1.45
maximum depth 95% confidence level	5.09	N/C	5.12	3.09	
minimum depth 95% confidence level	3.69	N/C	3.10	2.51	

N/C results not comparable as block cured upside down.

For the 9.7 MPa standard cure block the difference between the block top and base is 3 % which is not significant, while for the solar cured block the difference is a significant 44 %. For the 2 MPa solar cured blocks the difference between the top and base is 131 %, which is also significant. However, the data for the standard cure 2 MPa block is not comparable as this block was inadvertently cured upside down, resulting in a stronger top and weaker base than would otherwise have been the case. This does not allow a comparison of the relative change in top and base pressure for 2 verses 9.7 MPa compaction. This inadvertent inversion is highly unlikely to have affected the side scratch data.

Wet compressive strength tests

Table 5.9c shows the averaged results of the compressive strength testing. Each block was cut in half prior to compressive testing and hence the results are the

average of both block halves. An estimate of the spread in results is included in brackets and is based on a 95% level of confidence derived for similar blocks compacted to 9.7 MPa containing 5% cement. It can be seen that the strength of 2 and 9.7 MPa blocks is not equal, the 2 MPa block being 13% weaker than the 9.7 MPa block. A slight variation such as this would be expected as the empirical relation used to prepare the soil samples was derived from the results of tests conducted using the considerably smaller standard cylindrical mould described in BS1924. Although the strengths are not equal it is likely that the relative change between standard-cure and solar-cure will be similar. It can be seen that both blocks lose a significant degree of strength when solar-cured, 23 % for 2 MPa and 19.5% for 9.7 MPa. This indicates that the low pressure compaction blocks lose marginally more strength than the high pressure blocks. However such a small difference in strength loss would not be considered significant as the variation between similar blocks manufactured in the laboratory has been found to be $\pm 5.6\%$. Moreover block variation in field production is likely to be considerably higher, in the order of $\pm 25\%$.

Table 5.9c Wet compressive strength comparison between blocks manufactured by high and low pressure compaction subjected to standard and solar curing.

Block Identification	Wet compressive strength /MPa	% strength of solar cure relative to standard cure	% strength of low pressure compaction relative to high pressure compaction	Ratio of standard cure strength to solar cure strength
2 MPa standard cure	2.85 (2.69...3.01)	100	87	1.29
2 MPa solar cure	2.2 (2.08...2.32)	77	83	
9.7 MPa standard cure	3.29 (3.10...3.47)	100	100	1.24
9.7 MPa solar cure	2.65 (2.50...2.80)	81	100	

Comparison of scratch and compressive strength data

The scratch test was used to determine the surface shear strength of the blocks to estimate the variation in surface durability on poor curing. It is not known how such a test will relate to durability characteristics. It is however certain that a deeper scratch indicates a less durable block. For the purposes of this investigation the scratch depth squared was taken as a more representative measure of the volume of material removed than simply the scratch depth, in this way the increased width of the scratch with increasing depth was taken into account. However what is not known is the relation between scratch depth squared and durability, for example whether a doubling of scratch depth squared would reflect a halving of block durability or whether a sliding scale should be used. Further research of this nature is required but is beyond the scope of this thesis.

This having been said, it is apparent from the above results that solar curing reduced the block compressive strengths by approximately 20 % while the surface scratch depths squared increased by significantly more, 1300% and 1080% for 2 and 9.7 MPa blocks respectively. For both the scratch and the compressive tests the low pressure blocks suffered a greater deterioration in properties, although in each case the magnitude of the difference was too small for field production to be based solely on such a discrimination.

What is of more interest is the much greater loss of surface strength compared to bulk strength evident on solar curing. While a 20 % loss of compressive strength may be seen as surprisingly small, given the severity of the solar curing regime used, a 1000 % decrease in scratch resistance is likely to result in significantly less durable blocks. When handling the solar-cured blocks it was very evident to the author that the surface strength was substantially less than that of standard-cured blocks. Indeed, even with very delicate handling it was impossible not to damage the edges of the solar-cured blocks. Although durability has not been directly related to scratch

resistance it is the author's opinion that poor curing will have a significantly greater adverse effect on block durability than on block strength. For this reason it would be recommended that some form of durability test be included when block standards are being designed. An area which deserves future research effort would be to examine the nature of the relationship between scratch resistance and quality of curing. A scratch test of the type used above would appear to readily distinguish well cured blocks from poorly cured ones.

5.10 RECOMMENDATIONS FOR BLOCK CURING

On the basis of the research described above it is clear that poor curing practices may have a dramatic effect on the final block properties. Block durability, and to a lesser extent compressive strength are reduced by the premature loss of water during the first few days of curing. The published literature has tended to overlook the process of curing, concentrating on stabiliser and soil selection instead. If it is remembered that for *soil-A* a 20 % drop in compressive strength, as a result of poor curing, would be equivalent to halving the compaction pressure used to form the block, if well cured, then it would appear that more attention should be paid to curing.

The method of standard curing used in the above experimentation was based on that recommended by ILO (1987) "One method of keeping the block moist is simply to insert the block in a plastic bag". Although this was found to work successfully at the ambient temperature found in a British laboratory (20°C) when this method was used in conjunction with solar curing (35-45°C) it was not successful. The solar-cured plastic bag created a "green house" effect whereby the solar radiation caused the surface temperature of the block to become elevated above the local dew point for the water. This allowed water to evaporate from the block and condense on the inside of the bag before running down to collect in a pool. When tested for

scratch resistance there was no significant difference between bagged and open blocks. If the block had been shaded then this "green house" effect would not have occurred. The alternative curing procedure put forward by ILO (1987) whereby "freshly moulded blocks can be laid out in a single layer, on a non-absorbent surface, and covered with a sheet (e.g. plastic sheets) to prevent moisture from escaping" suffers from similar criticisms. Although it is said that "it is imperative that the moisture of the soil mix is retained within the body of the block for a few days", no mention is made of either shading the blocks from sunlight or of watering the blocks if they are seen to begin drying. Instead it is recommended that after the blocks complete their "primary cure" they should be stacked. "The top layer should always be wetted and covered, and the lower layers should be allowed to air dry and achieve maximum strength".

Maintaining all surfaces of the blocks in a moist condition should be considered to be of great importance during the early stages of curing. To this end the blocks should be shaded from direct sunlight and if possible from drying winds. This is an onerous condition on a small commercial blockmaker if the blocks are cured in the common configuration of being laid out in a single layer on the ground. If however the blocks can be stacked say 4 or more blocks high, the condition becomes much easier to meet. The blocks therefore should be stacked in a closely packed formation as soon as they are ejected from the mould, if they possess enough green strength. Low pressure compaction may not provide sufficient green strength to allow immediate stacking but high pressure compaction usually will. The stack should be covered with a layer of material to further reduce water loss. A layer of straw or reeds would be suitable with a layer of plastic laid beneath this if desired. If the blocks are seen to lighten in colour, indicating water loss, they should be re-wetted by sprinkling with water. The fresh blocks should stay in such a stack for seven days. At the end of seven days the covering material may be removed and the

blocks allowed to dry out in situ. If, during humid conditions, drying takes more than two weeks, subsequent block stacks should be restacked in a more open formation at the end of the seven-day period. If this method is followed strength and durability reduction resulting from water loss during curing will be minimised.

5.11 CONCLUSIONS CONCERNING CHAPTER FIVE

The work which has been reported in this chapter has examined the costs and benefits associated with high and low pressure compaction. The empirical relation derived for *soil-A* has shown that the cured strength of a soil-cement block is more dependant on the cement content than the compaction pressure, a doubling in compaction pressure producing the same strength improvement as a 20% increase in the amount of cement used. The economic analysis has shown that for *soil-A*, high pressure compaction using conventional quasi-static machinery is a more expensive production route than low pressure, high cement by between 8 and 46 % for both high and low strength blocks.

However, blocks produced by high and low pressure compaction exhibit differences in their green strength, durability and resistance to poor curing. Such differences result in "hidden" differences in the quality of the final blocks, which could not be easily included in the economic model. As no previous research had been found which examined these areas, the experimentation reported in sections 5.7, 5.8 and 5.9 was carried out to assess the importance of compaction pressure on these block properties and to qualitatively determine if high pressure compaction might warrant the additional cost compared to low pressure compaction.

Green block strength was shown to be significantly higher for high pressure compaction. This is likely to result in reduced block breakage rates on block ejection and transportation prior to curing. Moreover it would allow blocks to be stacked to

a greater height on ejection from the mould and hence reduce the rate of water loss during the early stages of curing.

The effect of compaction pressure on block durability, determined by the water spray test conducted by Sutcliff, was minor. However it would appear that, although minor, a trend is apparent whereby for a given strength a more durable block will be produced by high pressure compaction with a reduced cement content.

The study of the effect of poor curing on block strength and durability showed that both the compressive strength and the durability would be reduced, durability being measured by means of a surface scratch test in this case. Although the compressive strength is reduced the reduction in surface durability appears to be far more significant and emphasises the importance of good curing practice. Moreover, in agreement with the water spray erosion test, high pressure compaction is marginally less susceptible to poor curing.

Each of the above results in isolation would not be sufficient reason to justify the additional costs of conventional quasi-static high pressure compaction. However when all are taken together there would appear to be a definite benefit resulting from production using high pressure compaction over and above the savings in cement costs for a given strength. The production efficiency would be improved through lower block breakage rates, the range of soil which may be stabilised is increased, earlier block stacking may reduce the water lost from the blocks during curing thereby improving both the strength and durability and for a given strength and curing regime high pressure compaction may produce blocks which are marginally more durable.

With the exception of lower block breakage rates and the improved stacking potential, these extra benefits are marginal. It seems unlikely that in a free market situation these benefits would warrant a 46% price differential (standard Sri Lankan model) to the end user. However if the machine cost may be brought down to the £1000-1500 range, as may be possible with a dynamic-type compaction machine, then

the price differential is greatly reduced. Such a machine could produce blocks which, without accounting for any reduction in breakage rate, would be only 2-12 % more expensive if produced in Sri Lanka, between 10% cheaper and 5% more expensive for rural Zimbabwe and between 7% cheaper and 2 % more expensive if produced in Sri Lanka with the higher cement cost (the figures given are the best and worst case based on both a 1.4 and 2.8 MPa strength standard and a machine cost varying from £1000-1500). If a high pressure machine may be designed to such a cost then it would appear that high pressure compaction may be justified both on an economic and a "hidden" benefit basis.

PART C:

DYNAMIC COMPACTION

CHAPTER 6

INTRODUCTION TO DYNAMIC COMPACTION

6.1 INTRODUCTION

The final section of this thesis will examine the process of dynamic impact for the purpose of compaction to high pressure. In part B the quasi-static compaction process was examined in some detail. From this examination it was concluded that there are advantages in using high-pressure compaction, namely:

- reduced stabiliser content for a given strength
- increased density
- wider range of soil may be stabilised
- increased durability
- reduced susceptibility to poor curing
- increased strength of the fresh compact
- reduced block breakage rates
- the ability to stack cure on demould.

However these benefits are difficult to economically quantify. The primary benefit to the block manufacturer is the saving in stabiliser costs, while the primary drawback is the substantially increased purchase cost of a high-pressure machine.

Dynamic impact deserves investigation for two distinct reasons. Firstly a high-pressure machine, based on a dynamic method of force application, is likely to be

cheaper than a conventional quasi-static one. Secondly there is evidence to suggest that dynamic force application may produce a greater increase in density at depth than quasi-static compaction. Hence it may produce blocks with a more uniform density distribution giving greater compressive strength and durability, for a given mean density.

The purpose of the following investigation is to establish whether dynamic compaction may produce blocks equivalent to those produced by high-pressure quasi-static compaction without a significant additional expenditure of energy and also to establish whether any additional benefit in terms of compressive strength for a given density is evident as a result of dynamic compaction.

6.2 MACHINE IMPLICATIONS OF DYNAMIC COMPACTION

As discussed in chapter 1, the quasi-static force application approach appears to have been widely followed as a result of the early work done with simple Cinva Ram type devices which compacted to low pressure, around 2 MPa. At such a pressure the force which must be applied to a standard size block is 4 tonnes. The gearing ratio required to convert the force which one person may supply, to that which is required, is 116 (based on an operator force of 700 N). Although this is large and will entail significant transmission losses, it is achievable using a toggle lever arrangement on simple plain bearings. Hence these machines may be inexpensively manufactured by local artisans.

The research conducted in Part B of this thesis has shown that there are advantages to compacting to higher pressure, around 10 MPa. However at this compaction pressure the gearing ratio required rises to 580. This is not feasible with a toggle lever system operating on plain bearings and hence this type of machine

incorporates an additional hydraulic circuit which greatly increases its cost. Machines of this type, such as the Brepack, are too expensive to allow the manufactured blocks to be cost competitive with those produced on a low-pressure machine (see economic analysis chapter 5). A dynamic impact type machine would not suffer from the fundamental drawbacks associated with slowly applying a large force. These drawbacks may be summarised as follows:

1. For quasi-static compaction the full force must be transmitted through elements which move relative to each other. This leads to high wear rates and a short machine life. The wear rate is particularly high for soil compaction, where grit contamination is unavoidable, unless expensive sealed bearings are used or a regular daily maintenance programme is followed.
2. The compaction force must be transmitted through the body of the machine hence requiring it to be relatively massive, more so for high-pressure compaction where the transmitted force is of the order of 40 tonnes.
3. To manually generate the required compaction force a very large gearing ratio is required.

For a dynamic impact compaction machine there would be no large force transmission through elements moving relative to each other. Guidance of the impactor mass would be the area most affected by frictional wear, however the guidance forces would be low. The impact mould must be strong enough to resist the applied shock loading but would not have to transmit a high static load in the way that the lever link must for quasi-static compaction.

The large gear ratio required may be achieved by "dynamic lever". Potential energy is supplied to the impactor weight by raising it slowly; it is then released and falls gaining kinetic energy which is given up as a large force exerted for a very short

time as it decelerates on striking the block. In principal a dynamic machine may be capable of providing the advantages of high-pressure compaction and be significantly cheaper to produce than the equivalent hydraulic machine. Moreover it could still be manufactured by local artisans.

6.3 THE POTENTIAL BENEFITS OF DYNAMIC COMPACTION FOR BLOCK PROPERTIES

The research conducted by the Road Research laboratory (Williams and Maclean, 1950, see chapter 1) appeared to indicate that for road compaction, dynamic impact compaction by frog-rammer was able to increase soil density to a greater depth than that for compaction by a variety of rollers which, it has been assumed, are broadly equivalent to quasi-static compaction. Compaction of the soil-cement mix inside a constraining mould is essentially a process of air expulsion and, to a lesser extent, particle rearrangement and water migration over small distances. For road compaction the soil is unconfined which may allow easier expulsion of air during compaction, the permeability of the surrounding soil is largely unaffected by the impact blow and hence would allow air to be expelled laterally. For block compaction the soil is contained within a rigid impermeable mould and any expelled air must leave the mould solely from the impacted side. Thus, if the permeability of the soil is rapidly reduced during the impact blow then the air contained in the soil might become trapped, acting as a soft spring, and preventing permanent compaction of the soil mixture. However if the interface between the soil mixture and the mould wall can act as a high permeability channel to allow the passage of the expelled air, then compaction may occur. The successful dynamic impact compaction of soil-cement blocks by Agas Groth (1984) appears to suggest that the possible air spring

phenomena either does not occur or is not large enough to significantly retard densification.

Compaction by dynamic impact produces a large force in a very short period of time, generating a pressure wave. It is the duration of the resulting pressure peak which is likely to be of significance for block compaction. It will take a finite time for air to be expelled from the mould and this time will depend on the driving pressure gradient and the instantaneous soil permeability. For impact compaction the driving pressure is generated over a much shorter period of time and in consequence either the effective pressure gradient must be of greater magnitude or the instantaneous permeability must be increased relative to quasi-static compaction. The research conducted by the Road Research Laboratory has indicated that air expulsion (or temporary compression) is adequate to allow soil densification to occur in an unconfined situation, while the blocks produced by Groth, appear to confirm that air expulsion is also adequate in a confined case. If confined dynamic compaction does allow for adequate air expulsion and provides a more uniform density distribution then it would appear to be a more appropriate method of compaction than quasi-static.

6.4 THE APPLICATION OF AN IMPACT BLOW

The characteristics of an impact blow may be defined by the mass and velocity of the impactor immediately prior to contact with the soil. For a given applied kinetic energy per blow (kinetic energy = $\frac{1}{2} \times \text{mass} \times \text{velocity}^2$) an infinite number of mass and velocity combinations may be used (near zero velocity being quasi-static compaction), hence the impactor may have an infinite number of momentum magnitudes (momentum = mass x velocity). The kinetic energy of the impactor at the moment of striking determines the maximum amount of energy which may be transferred to the soil while the momentum of the impactor reflects the time it will

take to reduce the velocity of the impactor to zero (for a given retardation force). For a given impact energy, the larger the impactor mass, the higher the impactor momentum and the longer the time it will take to stop the impactor.

For impact compaction there are three variables to consider: the total level of energy applied to the soil, the energy applied per blow and the impactor momentum immediately prior to contact with the soil. It is likely that the level of energy applied to the soil will show the same type of relation to compressive strength as that found in chapter 4 for quasi-static compaction, namely that compressive strength will increase with increased compaction energy expended but that the increase will become progressively reduced as the energy level is increased. It might also be expected that there will exist an optimum level of energy per blow in which to apply any given energy level and similarly that there may exist an optimum impactor momentum for a given energy level.

6.5 MODELS TO DESCRIBE THE PROCESS OF COMPACTION BY IMPACT

Four models were initially postulated to describe the internal compaction mechanisms likely to occur on dynamic compaction; a "Fast" Quasi-Static Model, an Airlock Model, a Soft Hysteric Spring Model and a Compression Wave Model. Each of these models is presented as an idealisation, no single model attempts to explain all of the expected complexities.

6.5.1 FAST QUASI-STATIC MODEL

The Fast Quasi-Static Model assumes that the mechanisms which operate in quasi-static compaction (examined in chapter 4 section 4.2) also operate in dynamic compaction and that the increased velocity of the compacting piston has no significant

effect. The process of quasi-static compaction is not fully understood but it is known that it is not a hydrostatic process and that friction causes a reduction in compaction with depth.

For a given applied energy per blow, if the velocity of impact was immaterial, it would be expected that differences in impactor momentum would have no effect on the compaction process. It would also predict that a single high energy blow would cause greater densification than a single low energy blow. Moreover the density increase with successive blows would reduce in a manner similar to that seen in the applied pressure cycling of quasi-static compaction.

6.5.2 AIRLOCK MODEL

The Airlock Model assumes that compaction efficiency depends on the ability of entrained air to escape from the soil. As the applied impactor velocity is increased so the rate of permeability reduction in the upper layer of the cylinder increases (as a result of both vertical densification and the Poisson-type expansion discussed in chapter 4). As the upper layer's permeability decreases so the rate at which the air may be expelled reduces and less of the entrained air may escape in any given time, thereby reducing the degree of compaction. However it should be said that this would only be the case provided that the pressure gradient driving the expulsion of the air remains similar. Any rise in the driving pressure gradient may partially or wholly mitigate any reduction in permeability. If the driving pressure gradient increased more rapidly than the reduction in permeability with an increase in impactor velocity, then air expulsion might even be increased.

Assuming that the reduction in permeability was the more significant factor, the Airlock Model would predict that for a given applied energy per blow, a faster impactor would produce less densification than a slower one, namely that a higher

impactor momentum would be more efficient. It would also predict that, for a given total applied energy, a larger number of lower velocity blows would be more effective and in the limit quasi-static compaction would be more efficient than dynamic compaction.

6.5.3 *SOFT HYSTERIC SPRING*

The Soft Hysteric Spring Model assumes that above a certain low impactor velocity, the compacting soil velocity is sufficient for mould wall friction to reduce to its lower sliding or dynamic friction value. As this dynamic friction replaces static friction, the soil compresses more uniformly throughout its depth. Further, the air expelled from the soil would move radially towards the mould wall where it would then escape vertically upwards, towards the moving impactor. This would form an air curtain which would serve to further reduce the mould wall friction.

With friction reduced in this manner it would be expected that lower soil layers would experience higher compaction forces than would be the case for quasi-static compression and hence these lower layers would be expected to become more densely compacted.

The escaping air would provide the basis for hysteresis losses. It would produce a dissipating resistance to compaction and in the process of its expulsion, absorb energy. As the impactor moved down into the mould, the soil would behave as a rising rate spring and provide increasing resistance until the impactor's velocity was reduced to zero. At this point the soil too would have zero velocity and the sliding friction would return to the larger static friction value. The amount of subsequent expansion of the compressed soil (the amount of hysteresis exhibited) would then depend on the amount of applied energy used in overcoming the initial mould-wall friction, the amount of energy absorbed by air expulsion and the level of final static mould-wall friction.

This model would predict that, for a given energy per blow, as the velocity of impact was increased from near zero, so the effect of mould-wall friction would be reduced and a more uniform densification would occur. It would predict that for a given low energy per blow, a high velocity (low momentum) blow would be more effective than a low velocity one (high momentum). If the airlock phenomenon may be ignored (section 6.5.2), it would also predict that a single high energy blow would be more effective than a number of lower energy blows of the same cumulative energy.

At high velocities this model should be modified to include a compressions wave phenomenon (see Compression Wave Model).

6.5.4 COMPRESSION WAVE MODEL

The Compression Wave Model is an extension of the Soft Hysteric Spring Model. As the impact velocity is increased, there comes a point at which the soil spring propagates a compression wave superimposed on its existing compression.

When a spring is compressed by a moving mass, one of two things may happen. If the velocity of the impacting mass is slow then the spring compresses uniformly, if the velocity of impact is high then differential compression may occur. Differential compression allows the region of the spring hit first to compress more than lower layers of the spring as a result of mass inertia. The spring layer closest to the impact region accelerates until it is travelling at the same velocity as the impacting mass. During this acceleration this section of the spring is also compressing. Once this section of the spring is travelling at the same velocity as the impactor, the energy which was stored as spring potential energy, during the compression of this section of the spring, is released. This stored energy then further accelerates this section of the spring, generating a compression wave, which moves away from the impacting mass at a velocity higher than the impacting mass. The

generation of such a wave may be thought to be equivalent to a partially inelastic collision of two bodies, governed by Newton's experimental law of impact. The relevant mechanism of spring compression is determined by a function of the velocity and momentum of the impactor, the local spring constant and the mass (inertia) of each element of the spring.

The Compression Wave Model assumes that when a blow of sufficient energy and velocity is applied, a localised compression wave is generated and imposed on the overall compaction of the soil. This compression wave moves ahead of the impactor mass as a band of over-compressed soil. The band of over-compressed soil might be expected to compress and trap more of the entrained air in situ, rather than to expel it as would be the case for slower compression. In consequence it would be expected that compaction efficiency would drop as the velocity of impact was raised beyond the value at which, for the given set of conditions, such a compression wave phenomena would occur.

The trapped air would be compressed during the passage of the compression wave, storing energy, which could then be released once the localised over-compression had reduced. Once the compression wave reached the base of the mould it would be reflected back towards the impactor as a rarefaction or tensile wave. If it is remembered that confined soil may show a high compressive strength but that the tensile strength under the same circumstances is comparatively negligible, it may be imagined that the passage of any tensile wave may cause the localised fracture of the compacted soil. Moreover it is likely that any compressed air will decompress along any lines of material fault such as small tensile fracture cracks and in the process exaggerate them. We should therefore expect that if air over-compression does occur to a significant extent, there would be signs of planes of fault, these fault planes being caused by the escape of compressed air following channels possibly initially generated by the passage of the reflected tensile wave.

This model assumes that the Soft Hysteric Spring Model would operate until the energy of impact, for a given impactor mass, was raised above a certain value, sufficient to produce a compression wave. Once this energy of impact was exceeded the compaction efficiency would drop. For a given total applied energy this would indicate that there is an optimum level of energy per blow. Below this optimum the soft hysteric spring mechanism would be operating at less than full efficiency. At the optimum, the soil would be fully compressing just before the onset of a compression wave. Above the optimum, compression waves would be disrupting the densification as a result of the compression rather than expulsion of the entrained air and its subsequent rapid decompression.

6.6 INTRODUCTION TO THE EXPERIMENTAL INVESTIGATION OF DYNAMIC COMPACTION

The purpose of the investigation into dynamic compaction, which is described in the following sections, was to examine:

- whether dynamic compaction is capable of producing blocks equivalent in density to those produced by quasi-static compaction
- whether the energy required to dynamically form blocks of a given density is of greater, lower or the same magnitude as that needed for quasi-static compaction
- whether there exists an optimum number of blows for a given level of applied energy
- whether for a given applied energy level per blow, impact momentum has an effect on compacted density
- whether a block produced by dynamic compaction will be stronger than a block produced by quasi-static compaction for a given block density

6.7 EXPERIMENTAL DESIGN

In order to assess the potential of impact compaction for the production of stabilised blocks it was necessary to design a test rig capable of applying a consistently repeatable amount of energy by one or more blows. This energy should be provided by impactors of various masses travelling at various velocities so that the effect of impactor mass may be examined while holding the applied kinetic energy constant.

The experimental rig used by Groth consisted of a rope and pulley arrangement to raise a single weight which was dropped from varying heights by releasing the rope. It is no longer possible to use such a rig in a British University as it fails to meet the safety criteria now required by the Health and Safety Executive. In order to conduct this series of experiments a new impact rig had to be designed and built. The new impact rig (see appendix K fig K1) was designed to ensure that the impactor remained completely enclosed within a finger-proof inner safety cage at all times, this also performing the role of impactor guide system, and could only be removed from this guide system while the operator was outside a second locked safety cage. In conjunction with the double safety cage, a system of electronic interlocks was included to render the electromagnet-based weight raising device inoperable with the outer cage door open and instantly to deactivate the electromagnet, causing any weight being lifted to fall within the inner safety cage, should any attempt to open the door of the outer safety cage be made while an experiment was under way.

The rig was designed around a standard cylindrical mould, 200mm high 100mm diameter, used for curing concrete samples for quality control purposes (BS 1881). The height and weight combinations used for the experiments were found by extrapolating the energy per unit volume used when quasi-statically compacting a standard size block (see section 6.7.1 below).

The rig consisted of a 2m pneumatic ram fitted with an electromagnet to raise the impactor weights to predetermined heights where they would activate a micro-switch, thereby turning off the electromagnet and thus allowing the impactor to fall freely until it contacted the surface of the soil mixture. Full details of the experimental rig are included in appendix K.

6.7.1 CALCULATION OF THE ENERGY APPLIED BY THE IMPACT RIG

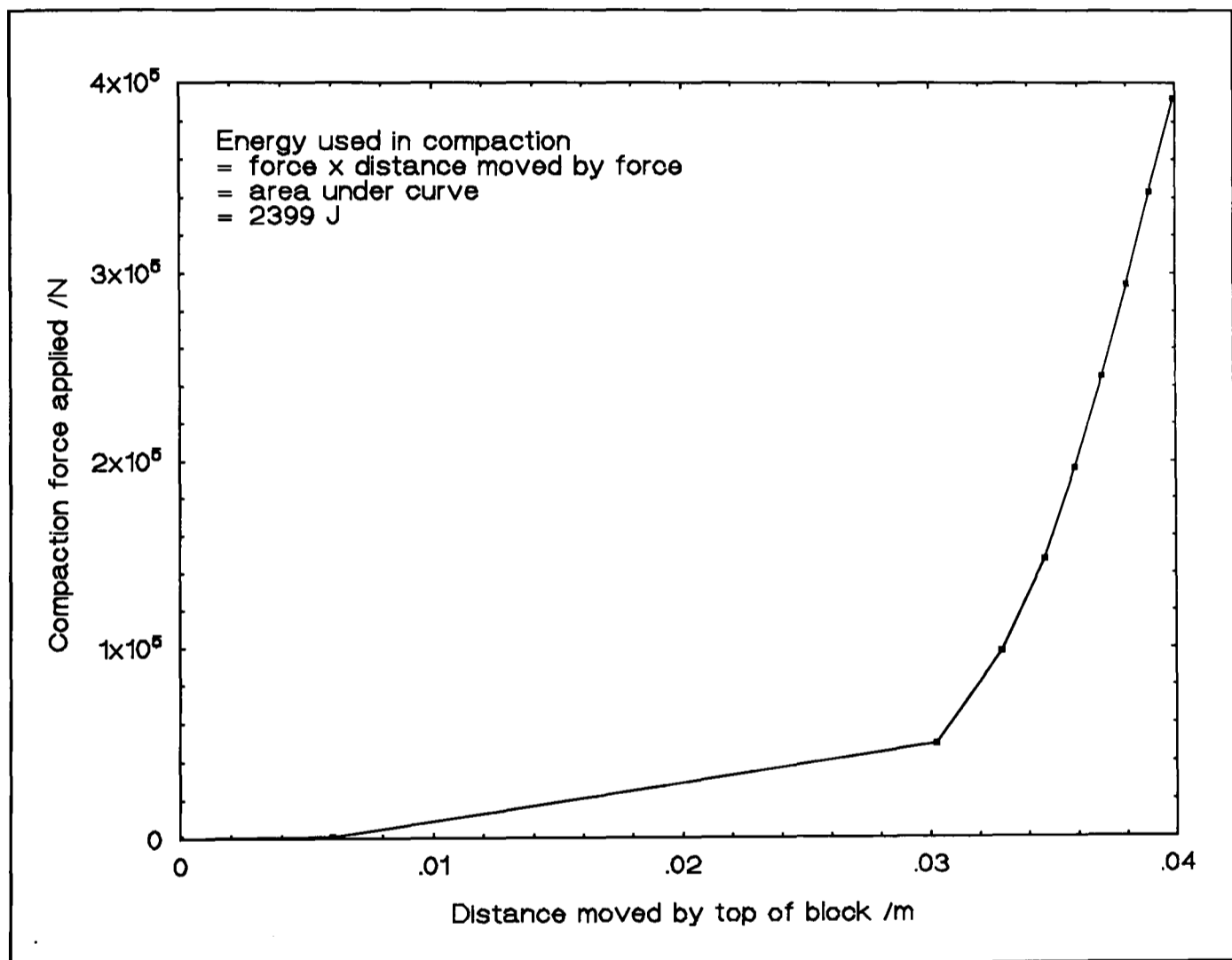

Figure 6.7 Energy used by the quasi-static compaction of a standard-size block to 9.7 MPa.

The energy to be applied to the cylindrical mould was calculated by scaling the energy used in quasi-statically compacting a standard-size block to 9.7 MPa, using the compacted volume as the scaling factor. The energy used to compact a standard-size block was found by plotting the applied compaction force in Newtons against the distance moved by the top of the mould in metres and calculating the integral area

(the area under the curve), using a Simpson rule algorithm. The data used for this calculation is shown graphically in figure 6.7, a value of 2400J per standard-size block has been used in subsequent calculations. The compacted block volume was calculated to be $4.06 \times 10^{-3} \text{m}^3$ hence the energy per unit of compacted volume was found to be $591 \times 10^3 \text{ J/m}^3$. The final compacted height of the soil cylinder was to be 100mm and hence the final volume of the soil compact was to be $785 \times 10^{-6} \text{ m}^3$. This then requires an applied energy level of 464 J ($591 \times 10^3 \times 785 \times 10^{-6}$) to produce compaction equivalent to that of 9.7 MPa quasi-static loading.

Having established the energy required of the impact blow, the mass and drop height combinations were calculated on the basis of potential energy (potential energy = mass x drop height x acceleration due to gravity), the impact velocity then found by assuming all of the potential energy was transferred to kinetic energy (kinetic energy = $\frac{1}{2} \times \text{mass} \times \text{velocity}^2$). A series of optimisation and compromise resulted in the maximum drop being set at 2.05m and three impact masses being set at 46.8, 35.0 and 23.35 kg. The combinations of drop height, impactor mass and number of blows which were used in the experimental investigation are given in table 6.7 (over leaf), all were designed to give a total cumulative impact energy of 464 J.

Full details of the experimental method used are given in appendix L.

Table 6.7 Impact combinations used to generate a total impact energy of 464J.

Impact mass /kg	number of blows	drop height /m	energy applied per blow /J	velocity per blow /m/s	momentum per blow /kg/m/s
23.35	1	2.026	464	6.3	147.20
23.35	2	1.013	232	4.46	104.09
23.35	4	0.506	116	3.15	73.60
23.35	8	0.253	58	2.23	52.04
23.35	16	0.127	29	1.58	36.80
23.35	32	0.063	14.5	1.11	26.02
23.35	64	0.032	7.25	0.79	18.40
35.00	1	1.351	464	5.15	180.22
35.00	2	0.676	232	3.64	127.44
35.00	4	0.338	116	2.57	90.11
35.00	8	0.169	58	1.82	63.72
35.00	16	0.084	29	1.29	45.06
35.00	32	0.042	14.5	0.91	31.86
35.00	64	0.021	7.25	0.64	22.53
46.80	1	1.011	464	4.45	208.40
46.80	2	0.505	232	3.15	147.36
46.80	4	0.253	116	2.23	104.20
46.80	8	0.126	58	1.57	73.68
46.80	16	0.063	29	1.11	52.10
46.80	32	0.032	14.5	0.79	36.84
46.80	64	0.016	7.25	0.56	26.05

CHAPTER 7

ANALYSIS OF EXPERIMENTAL INVESTIGATION OF DYNAMIC COMPACTION

7.1 IMPACT COMPACTION EFFICIENCY

The soil used for compaction was unstabilised *soil-A*. Cylinder density was used to determine the compaction efficiency. Density was found by recording the compacted cylinder height and mass on ejection from the mould. A full listing of the numerical results is given in appendix M.

Figure 7.1a shows a plot of final compacted bulk density against the number of impact blows for each of the three impactor masses used. In each case the soil sample received 279 J/kg¹ of applied energy or 464 J per cylinder. This graph shows a maximum density for all of the impactor masses occurs when the total energy was applied via 16 equal blows (each of 29 J). It also shows that for a given energy per blow a higher momentum blow is more effective. Above the 16 blow optimum there is an indication that this may be reversed and that a lower momentum blow may be more effective: the 64 blow samples show this reversal. However this is sufficiently remote from the optimum to be neglected for machine design purposes.

¹ This figure was chosen as equalling the energy per unit mass consumed when quasi-statically compressing a full-size block to a pressure of 9.7 MPa.

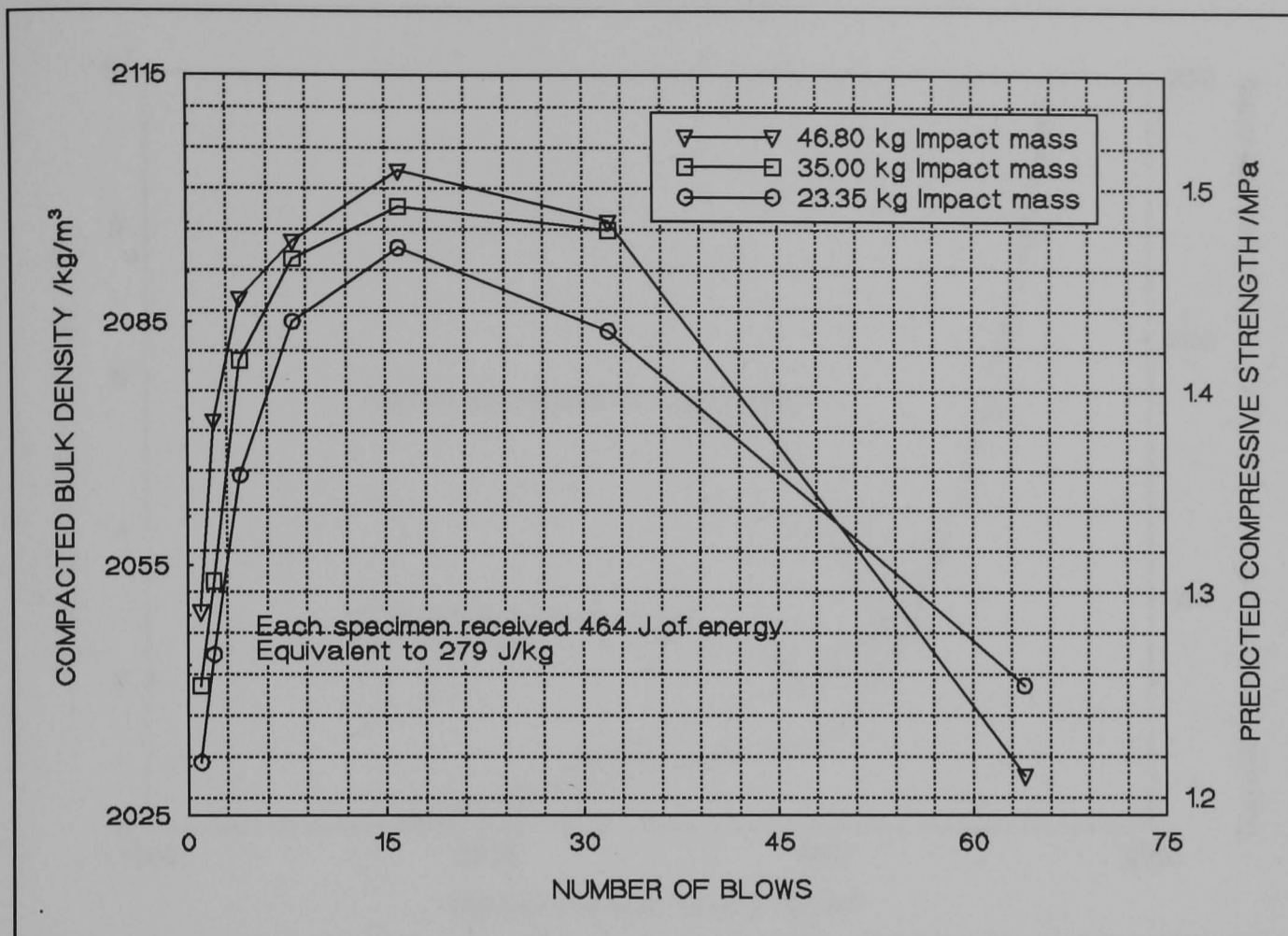

Figure 7.1a The effect of the number of impact blows on bulk density. Compressive strength values have been predicted using the empirical relation found in chapter 5, assuming a cement content of 5%.

Figure 7.1b and 7.1c respectively show the compacted density of a quasi-static full-size block and a quasi-static cylinder (the same mould as used for impact compaction). These figures include both the applied compaction pressure and the energy used during compaction. It can be seen that although the bulk density produced by a given applied energy per kg is different for the different moulds it is only slightly so: the cylinder required 8% less energy (257 J/kg) than a standard-size block (279 J/kg) to achieve a density of 2038 kg/m³. This should allow any subsequent comparisons between the cylindrical quasi-static and impact compacted samples to reflect the effects on standard-size blocks, however no direct testing of standard-size blocks compacted by impact has been conducted.

For both the quasi-statically compressed samples the resulting bulk density achieved at a given energy per kilogramme is significantly lower than that for impact

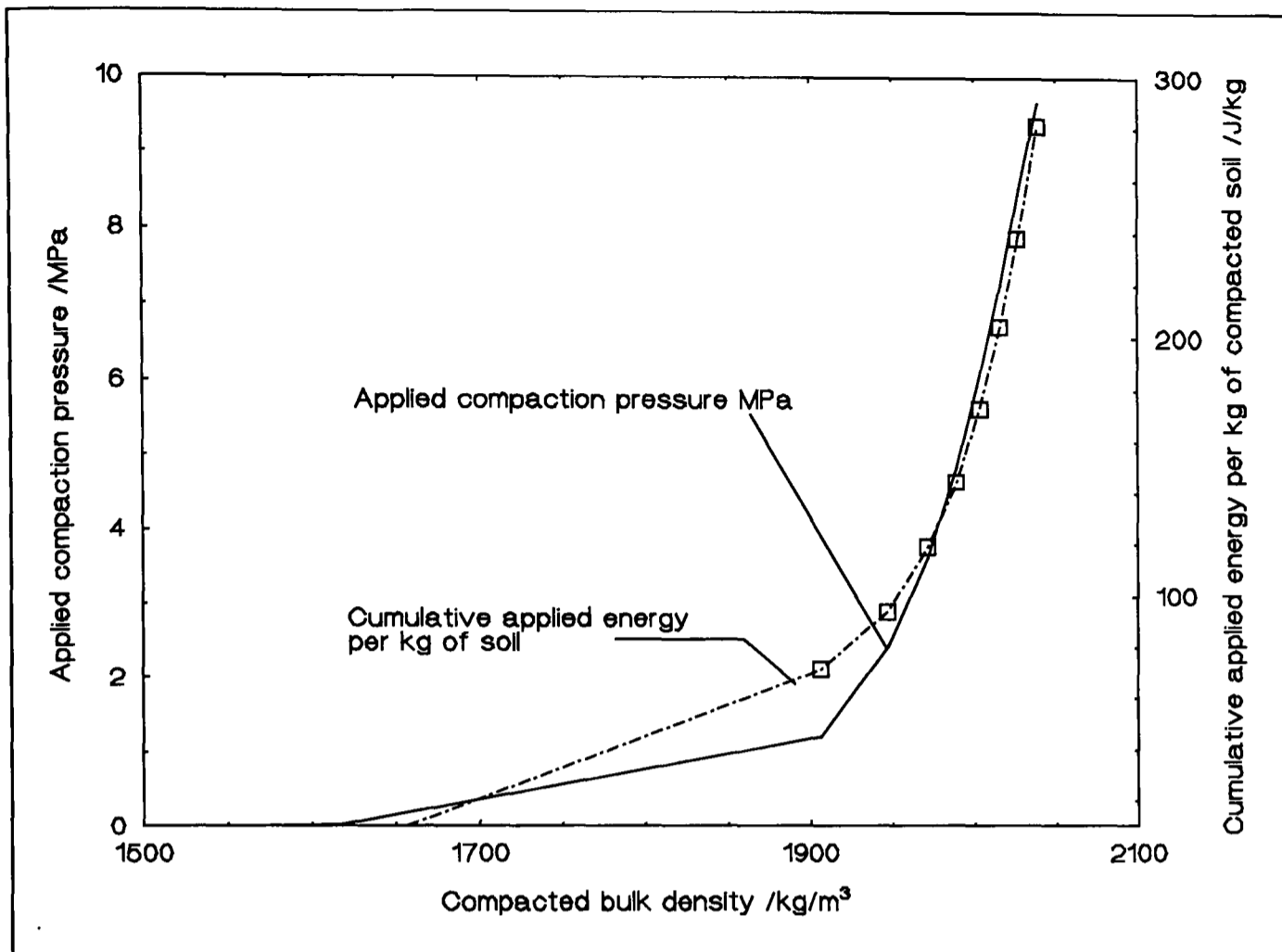

Figure 7.1b The density-energy-pressure relations for a quasi-statically compacted (standard-size) block. The soil used was unstabilised *soil-A* at 8% moisture content.

compaction, being between 2038-2048 kg/m³ for quasi-static compaction and between 2093-2103 kg/m³ for impact compaction. If it may be assumed that the density-to-strength relation found empirically for the small cylindrical samples may be applied, then this difference in bulk density equates to a 13% difference in seven-day compressive strength for a 5% stabiliser content, *assuming* that there is no additional benefit of greater uniformity in density for the impact compacted sample.

Impact compaction is thus capable of producing the same densification as quasi-static compaction, using less applied energy. If figure 7.3.1 (section 7.3.1) is examined it can be seen that when using only 9 blows of the 16 blow configuration, provided by the lightest impact mass (the least efficient) a density of 2046 kg/m³ may be achieved for an applied energy of 157 J/kg, an energy saving of 43% compared to quasi-static cylinder compaction (which required 274 J/kg for this density).

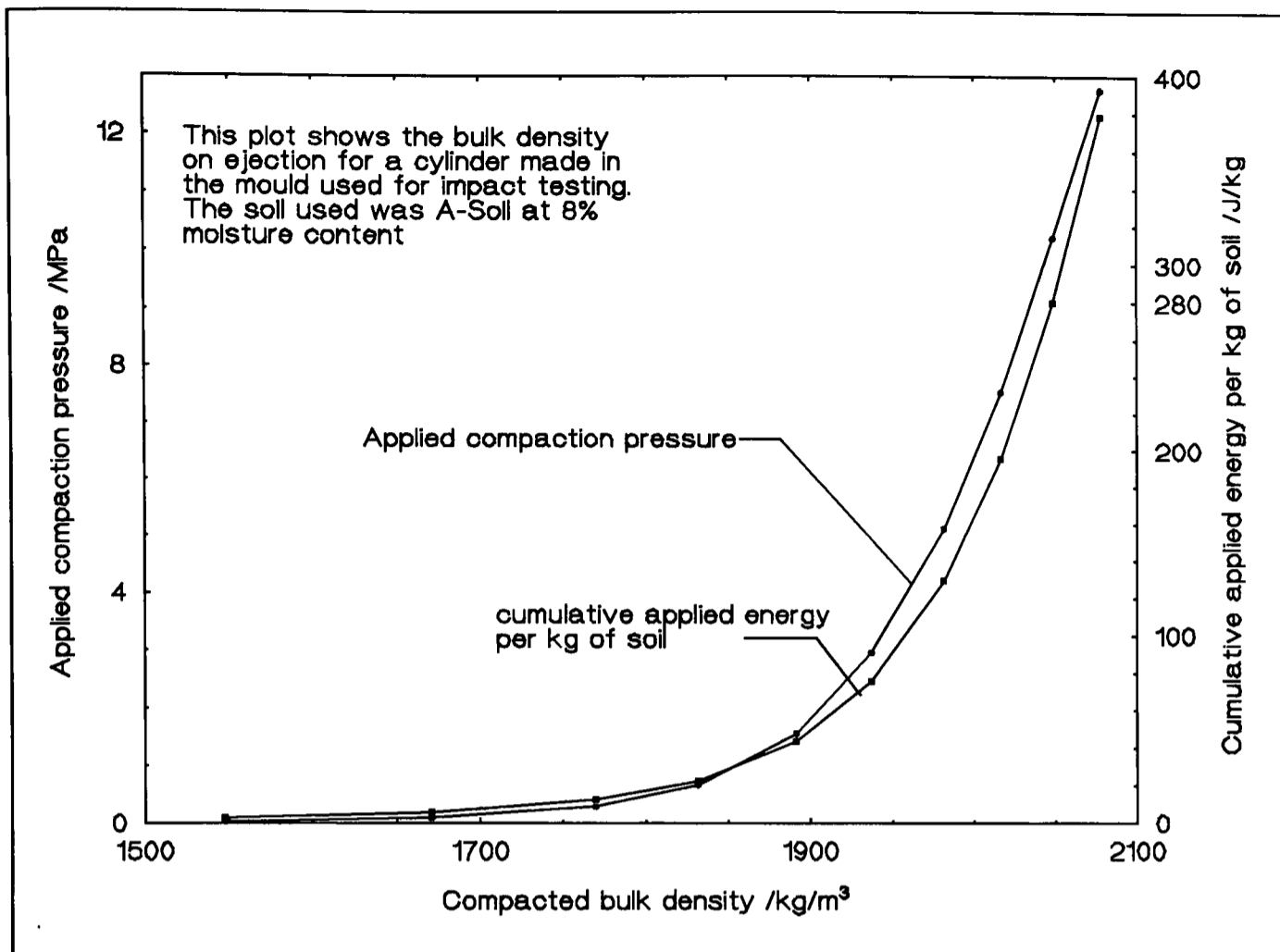

Figure 7.1c The density-energy-pressure relations for a sample compacted quasi-statically in the impact cylinder mould. The soil used was unstabilised *soil-A* at a moisture content of 8%.

Alternatively, the energy required to quasi-statically compact a sample to a density equivalent to that obtained by (279 J/kg) impact compaction would be 436 J/kg, an additional 56%.

Observations made during dynamic experimentation

It should be mentioned at this point that some of the cylinders produced by these impact blows were visibly flawed. The cylinders which were compacted by one, two and four blows of each mass displayed multiple radial cracks which lay roughly parallel with the top and bottom faces of the mould and increased in severity as the blow velocity increased. At and above eight-blow compaction these flaws were not visible.

A further point which should be mentioned is the ease with which the dynamically compacted cylinders were ejected from the mould. A qualitative comparison of the ease of ejection was made between cylinders compacted quasi-statically and dynamically. Dynamically compacted cylinders consistently required significantly less force to eject than quasi-statically compacted ones.

7.2 THE COMPRESSIVE STRENGTH OF IMPACT AND QUASI-STATIC CYLINDERS

To examine the effect of compaction method on compressive strength three cylinders were produced using the light mass to apply a total of 279 J/kg in 16 equal blows, using *soil-A* stabilised with 5% cement. The density produced by dynamic compaction was then replicated in three quasi-statically formed cylinders through compaction of an identical soil/stabiliser mix in an identical mould. In this way six

Table 7.2 Comparison of compressive strength for a constant bulk density produced by quasi-static and impact compaction. (*soil-A* + 5% cement at 8% moisture content).

CYLINDER IDENTIFICATION	BULK DENSITY /kg/m ³	COMPRESSIVE STRENGTH /MPa
Quasi-static 1	2051.4	1.910
Quasi-static 2	2048.6	1.897
Quasi-static 3	2062.5	1.999
Impact 1	2060.5	2.494
Impact 2	2058.0	2.435
Impact 3	2050.6	2.270
AVG Quasi-static	2054.2	1.935 (100%)
AVG Impact	2056.4	2.399 (124%)

cylinders of near equal density were produced and left to damp cure for seven days prior to testing for seven-day wet compressive strength. Table 7.2 shows the compacted bulk density and the seven-day wet compressive strength for each cylinder. It can be seen that for the conditions used compaction by impact produced, for the same density, a 24% increase in the compressive strength. This suggests that dynamic impact compaction does produce a more uniform distribution of density and consequently produces a stronger block for a given soil, stabiliser content and mean density.

It should be noted that the actual value of the compressive strength obtained is not that which would be predicted by the empirical relation derived in chapter 5 for slowly pressed smaller cylinders. This relation predicts that the cylinder should have a compressive strength of 1.3 MPa for a bulk density of 2055 kg/m³ and a cement content of 5%, whereas the average strength of the 3 corresponding cylinders is 1.935 MPa, approximately 50% higher. Moreover it may be noticed that the compacted density of the impact cylinders is 37 kg/m³ less than that for the same soil without the addition of cement (see Fig 7.1a). This is a result of the change in optimum moisture content when cement is added. The moisture content used had been optimised for quasi-static compaction. No moisture content optimisation tests have been conducted for impact compaction, it was assumed that as the soil has a low moisture sensitivity when quasi-statically compacted the same should be true for impact compaction. Moreover to correctly determine the optimum moisture content for each of the impact combinations used would have required at least an additional 252 cylinders to be produced. However it appears that the optimum moisture content should be specifically determined for the circumstances used for compaction.

Having indicated the above discrepancies, it is still possible to roughly estimate the combined impactive energy saving for strength equivalence to quasi-static compaction. The cylinders compacted by impact required 279 J/kg to reach a density

of 2056 kg/m³. Section 7.1 indicated that impact compaction required 43% less energy than quasi-static compaction to reach a given density and hence it may be inferred that the quasi-statically compacted cylinders required 489 J/kg. The impact cylinders were 24 % stronger than the quasi-static cylinders for this density and therefore for an equivalent strength the impact cylinders would require less densification. The density required may be calculated from the pressure-cement-strength relation, if it is assumed that the rate of change in strength with density is similar for this size of cylinder. A density of 2056 and a cement content of 5% would produce a strength of 1.31 MPa, a reduction of 24% in strength to 0.99 MPa would then require the density to reduce to 1977 kg/m³. If it is further assumed that the shape of the density-energy relation shown in figure 7.3.1 will apply, 279 J/kg producing 2054 kg/m³ instead of 2093kg/m³, then a density of 1977 kg/m³ would require 111 J/kg. Impact compaction to produce an equivalent strength to quasi-static compaction would then result in an energy saving of 77% (111 J/kg for impact and 498 J/kg for quasi-static). This figure should be treated with caution as it is based on several assumptions rather than direct experimental measurement however it is sufficiently large to suggest that it reflects a true trend. It would be concluded that impact compaction requires between 50 and 75 % less energy than quasi-static compaction for strength equivalence. This is a highly significant saving.

7.3 OPTIMISATION OF IMPACT COMPACTION

Unlike quasi-static compaction, the manner in which the energy is applied to the soil affects impact compaction efficiency. For impact compaction there are three prime variables; the total energy applied to the soil, the number of discrete blows in which this energy is applied and the momentum of each blow, if unequal blows are used then a fourth variable, the sequence of energy levels per blow is also important.

The following section describes the effect of each of these variables, although it should be remembered that they are inter-related.

7.3.1 TOTAL APPLIED ENERGY

It would be expected from the Fast Quasi-Static Model of compaction that a higher total applied energy should universally produce a greater final density. If figure 7.3.1 is examined it can be seen that this is not true. Figure 7.3.1 shows the density after successive impact blows (the 32 blow (14.5 J/blow) trace shows the

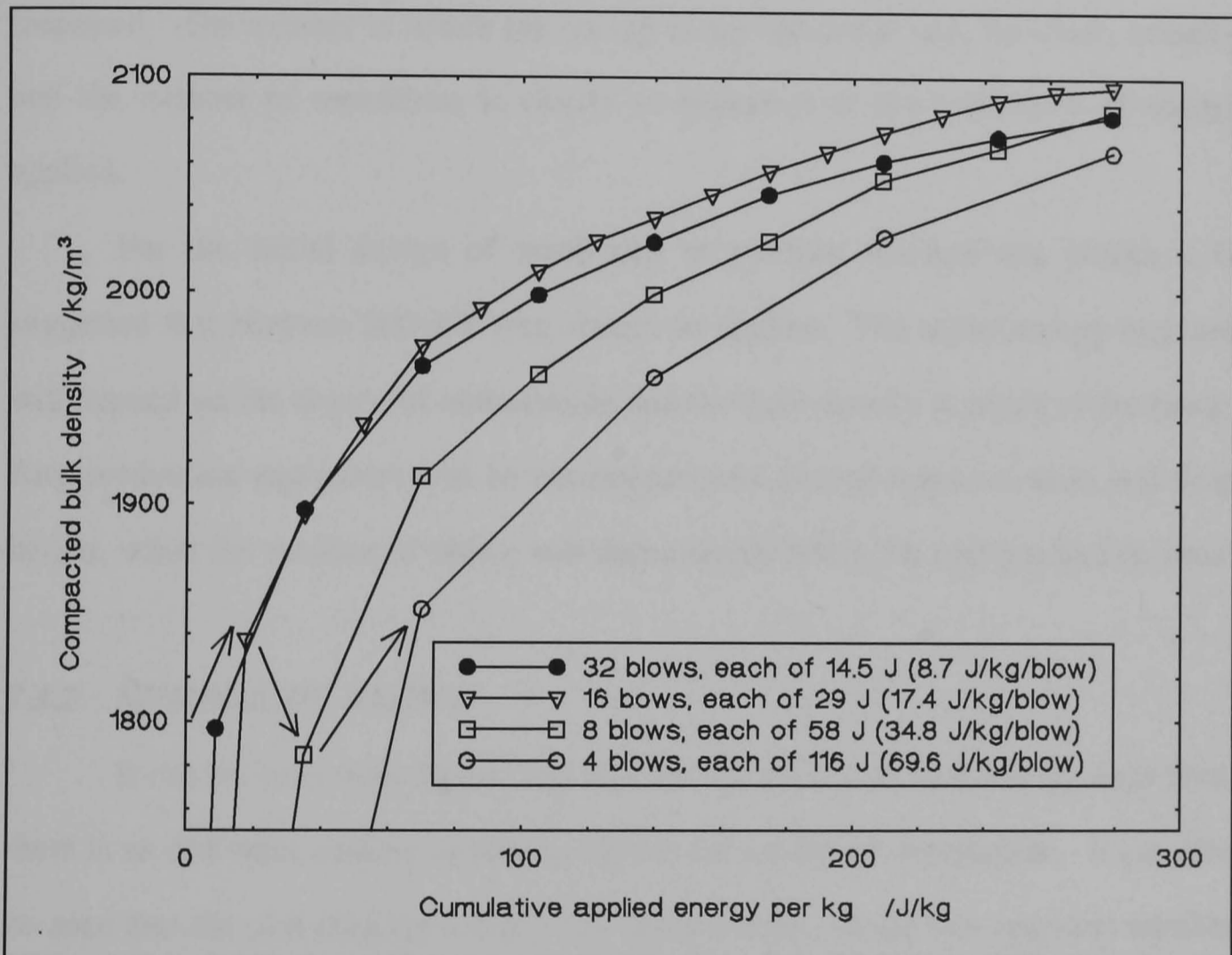

Figure 7.3.1 Density gain during discrete impact compaction. All samples were compacted with the 23.35 kg impactor. Each sample weighed 1.66kg, including weight of water.

result of the first blow and then every fourth blow). If the first blow of each trace is examined, the effect of increasing the total applied energy by increasing the drop height for a given mass can be seen. Density does not rise uniformly with the total applied energy: there is a discontinuity at the 16 blow sequence (29 J/blow). The

compacted density generally increases with increasing applied energy but there is a drop between the 29 and 58 J/blow level, as shown by the arrow sequence in figure 7.3.1. It would be expected that a 58 J blow would produce a more dense compact than a 29 J one, rather than the less dense one observed. After the drop in density at the 8 blow energy level the expected pattern of increased applied energy resulting in increased density recurs.

For a given blow strength, increasing the number of blows does increase the density. However the additional density gain falls as the number of blows is increased. The manner in which the energy is applied to the soil, the mass, velocity and the number of repetitions is clearly as important as the total level of energy applied.

For the initial design of machinery to produce standard-size blocks it is suggested that between 200-300 J/kg should be applied. The actual energy required will depend on the degree of optimisation and the final density required of the block. Any production equipment will be constrained to a limited impactor mass and drop height, while the number of blows will considerably affect the unit production time.

7.3.2 NUMBER OF BLOWS

It can be seen from figure 7.1a that for the particular total energy used here, there is an optimum number of blows (16) for most efficient compaction. It can also be seen that the plot displays a fairly flat characteristic around this optimum number of blows, between 8 and 32. Using the empirical relation derived in chapter 5 and assuming a 5% cement content, the variation in density between 8 x 58 J/blow and 32 x 14.5 J/blow corresponds to less than 3% variation in compressive strength. Similarly the difference in compressive strength between the lightest and heaviest impactor mass is also less than 3% at 16 blows, if the total energy is kept constant. This is a desirable characteristic for any impact machine design, suggesting that

although the manner in which the energy is applied affects the final density there is a degree of leeway around the optimum before any dramatic fall off in density is seen.

If figure 7.3.1 is again examined it can be seen that initially the highest rate of gain in density per unit of applied energy occurs when 29 J blows are used (the 16 blow sequence) but that after approximately the 200 J/kg level a higher energy of 112 J per blow (4 blow sequence) gives a greater gain. This would suggest that there could be savings in energy and compaction time, if a series of blows of increasing magnitude were used. Initial compaction could be performed by light blows and final compaction by heavier blows. Although it was noted in section 7.1 that very heavy blows (the 1-4 blow sequences) produced flawed samples, samples partially compacted by 8 (x29 J) blows of the 16 blow sequence did not show any signs of flaws when their compaction was completed with a single 232 J blow (corresponding to a 2 blow sequence). This indicates that decompression of air trapped by a compression wave (see Compression Wave Model in section 6.5.4) may be primarily responsible for the severity of the flaws observed and suggests that high energy blows may be used once the air fraction of the soil has been sufficiently reduced. Although varying the magnitudes of successive blows would require additional machine complexity, it would reduce the time required to compact each unit, if this was seen as a production constraint.

7.3.3 IMPACTOR MOMENTUM

Figures 7.3.3a and 7.3.3b show respectively the effect of momentum per blow and the total applied momentum on bulk density. Again the plot of momentum per blow shows a maximum density for the 16 blow sequence (29 J/blow). At most levels of momentum per blow it can be seen that a lower velocity (thus higher mass) blow produces a greater densification, it is only at very low levels that the higher velocity blow is more effective. It should be noted that the optimum momentum per blow is different for each of the masses.

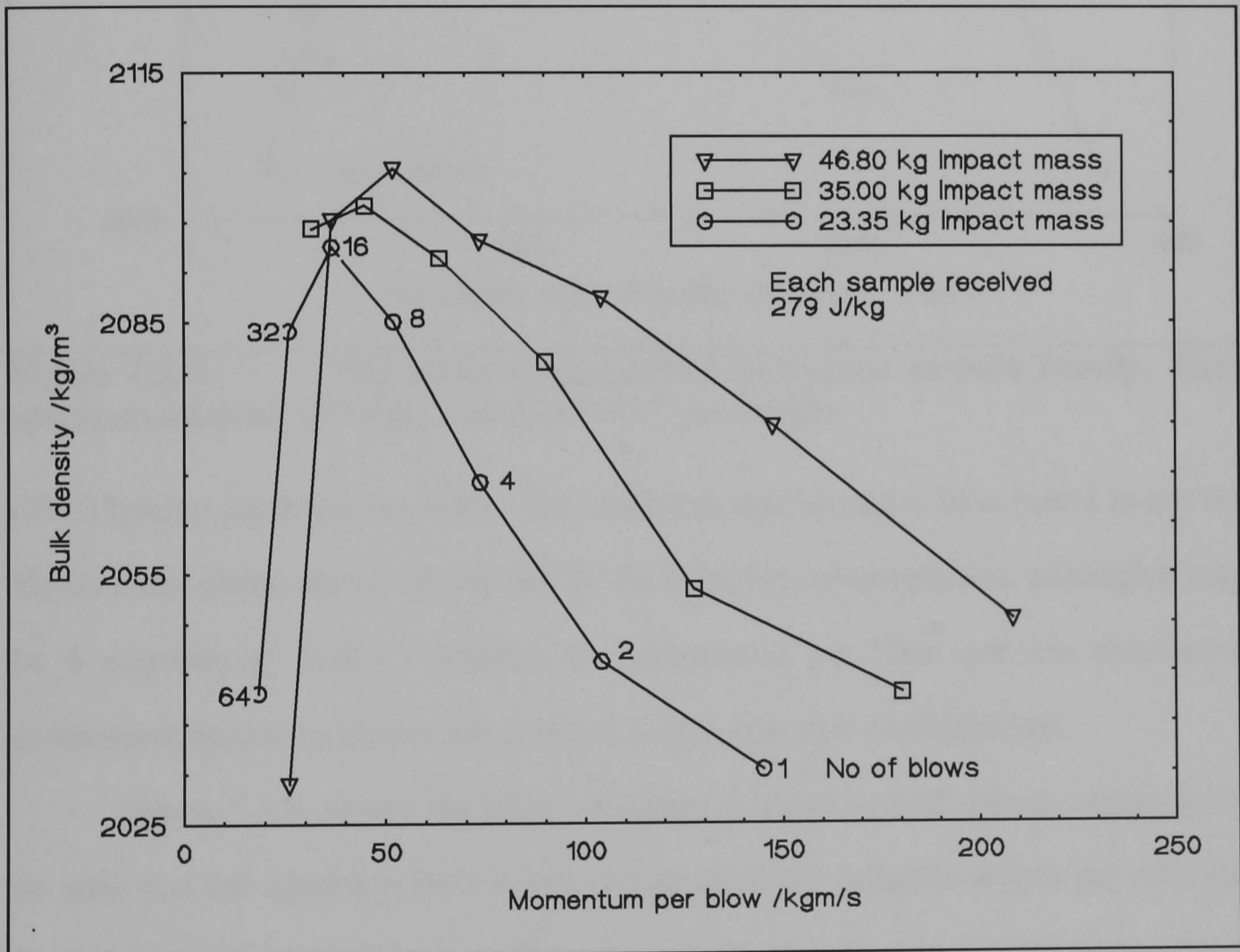

Figure 7.3.3a The effect of momentum per blow on compacted bulk density. Each sample received 279 J/kg or a total of 464 J per specimen.

If the plot of cumulative total applied momentum is examined it can be seen that up to 600 kgm/s the cumulative applied momentum is a good predictor of bulk density. The point at which the cumulative momentum ceases to be a useful predictor of compacted density is different for each of the masses used but occurs at the same

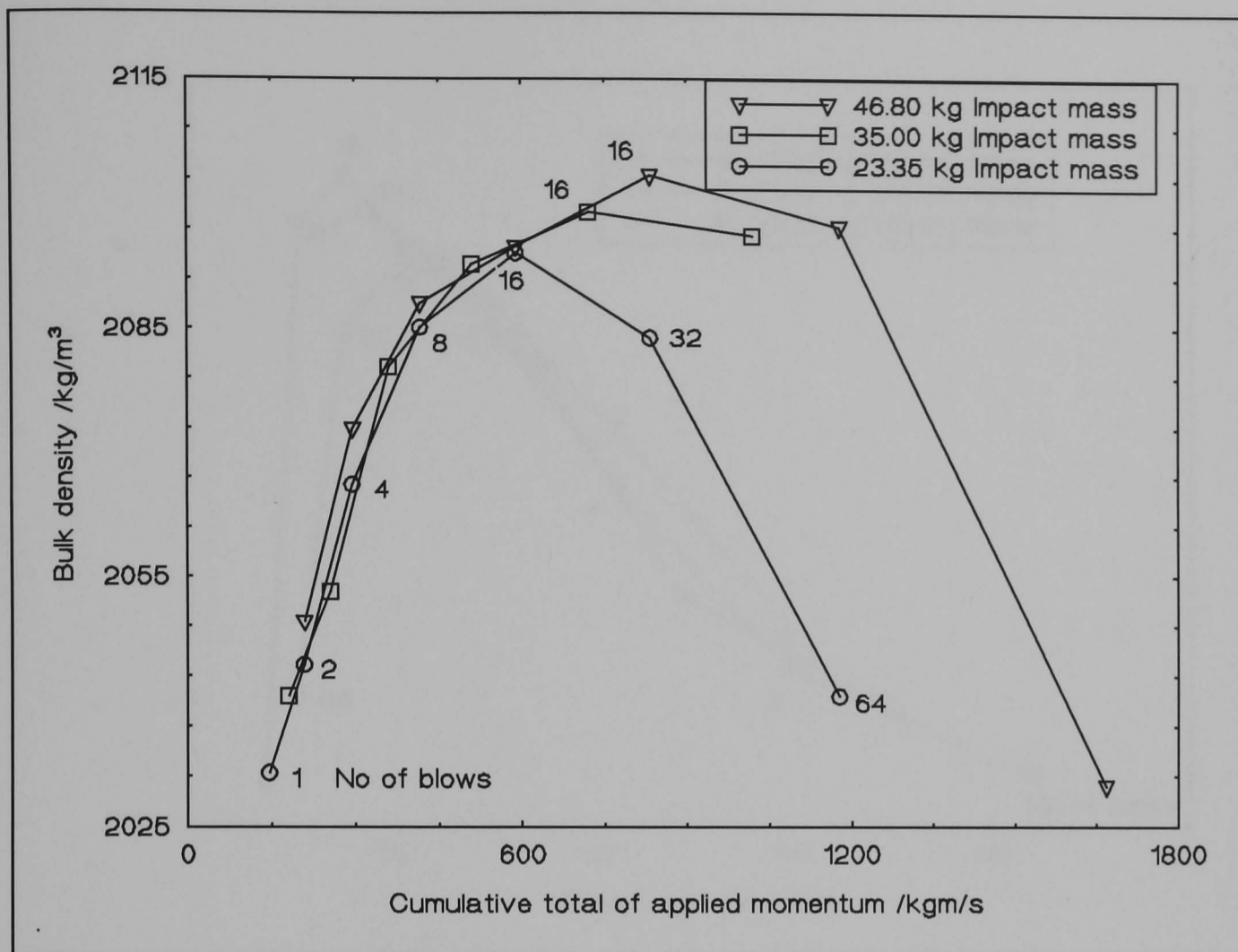

Figure 7.3.3b The effect of cumulative momentum on bulk density. Each specimen received 279 J/kg, a total of 464 J per sample.

(29 J) energy per blow for each. This indicates that impactor momentum is not the fundamental characteristic which defines the efficiency of compaction, although it may be a contributory factor. Neither the momentum per blow nor the cumulative momentum appear to dictate the position of the optimum configuration.

Figure 7.3.3c shows the effect of impact velocity on bulk density, again it can be seen that the optimum blow configuration does not coincide with a set velocity. It can be seen that the 16 blow configuration of the 46.8 kg mass has the same impact velocity as the 32 blow configuration for the 23.35 kg mass but that the resulting densities are different. Blow velocity alone cannot explain this discrepancy in density.

The mean optimum momentum for this set of experiments was centred on 45 kgm/s, at an impact velocity of approximately 1.4 m/s. The general conclusion on momentum would be that when operating near the optimum a higher momentum blow

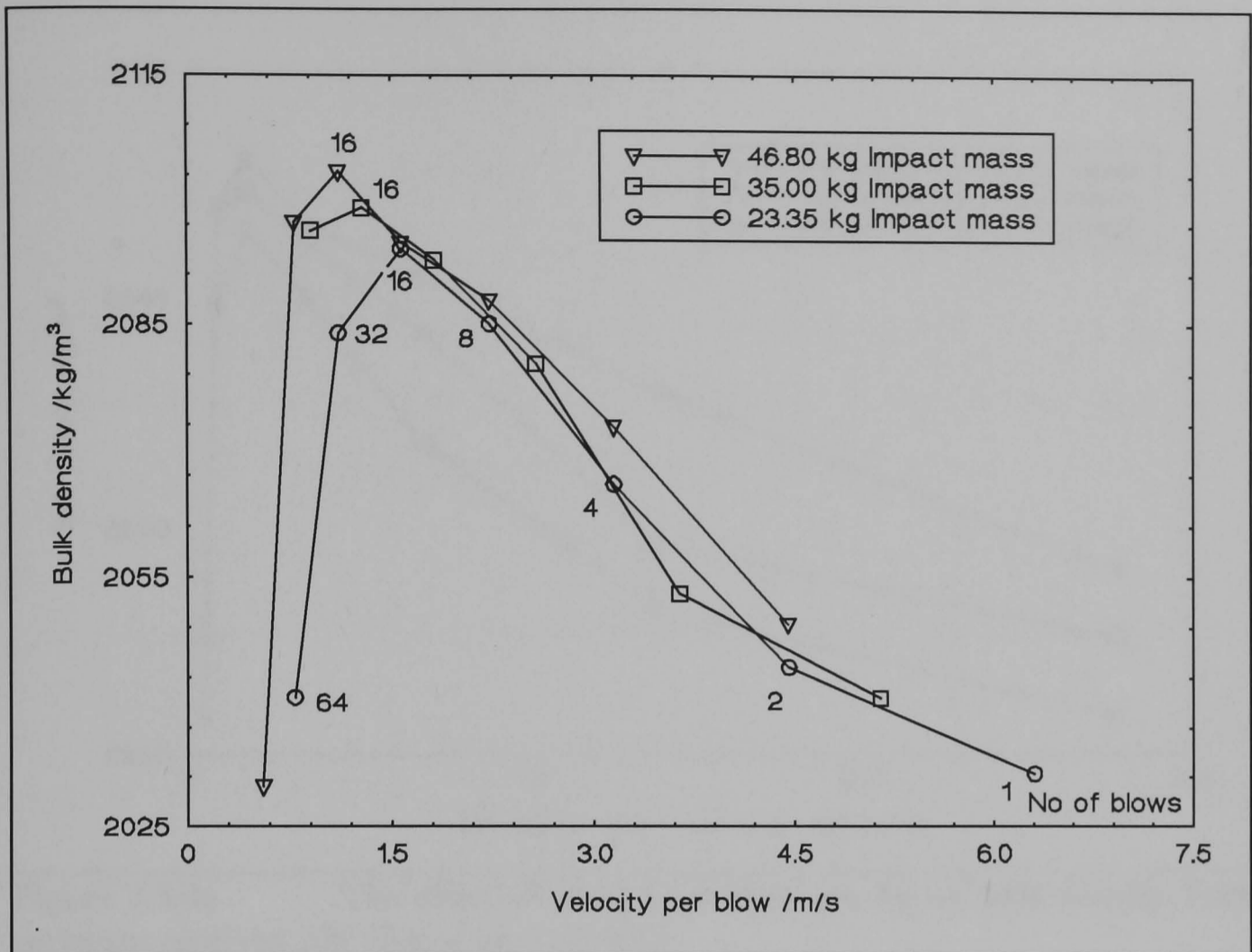

Figure 7.3.3c The effect of impact velocity on bulk density. Each specimen received 279 J/kg, a total of 464 J.

will be more efficient. For machine design this would require the largest practical impact mass to be used.

7.3.4 IMPACTOR ENERGY

Figure 7.3.4a shows the effect of energy per blow on the final bulk density (each sample having received 279 J/kg). This is similar to figure 7.3.3a in that at high levels of energy per blow a slower moving impactor creates a more dense cylinder, while at low energy levels per blow a faster moving impactor is more effective. Here the optimum 29 J per blow (17.4 J/kg/blow) is most clearly visible. It is the value of energy per blow which most precisely defines the optimum configuration for all of the masses used. This would indicate that however the under-lying mechanism of compaction acts and whatever the nature of the change which occurs at or around the

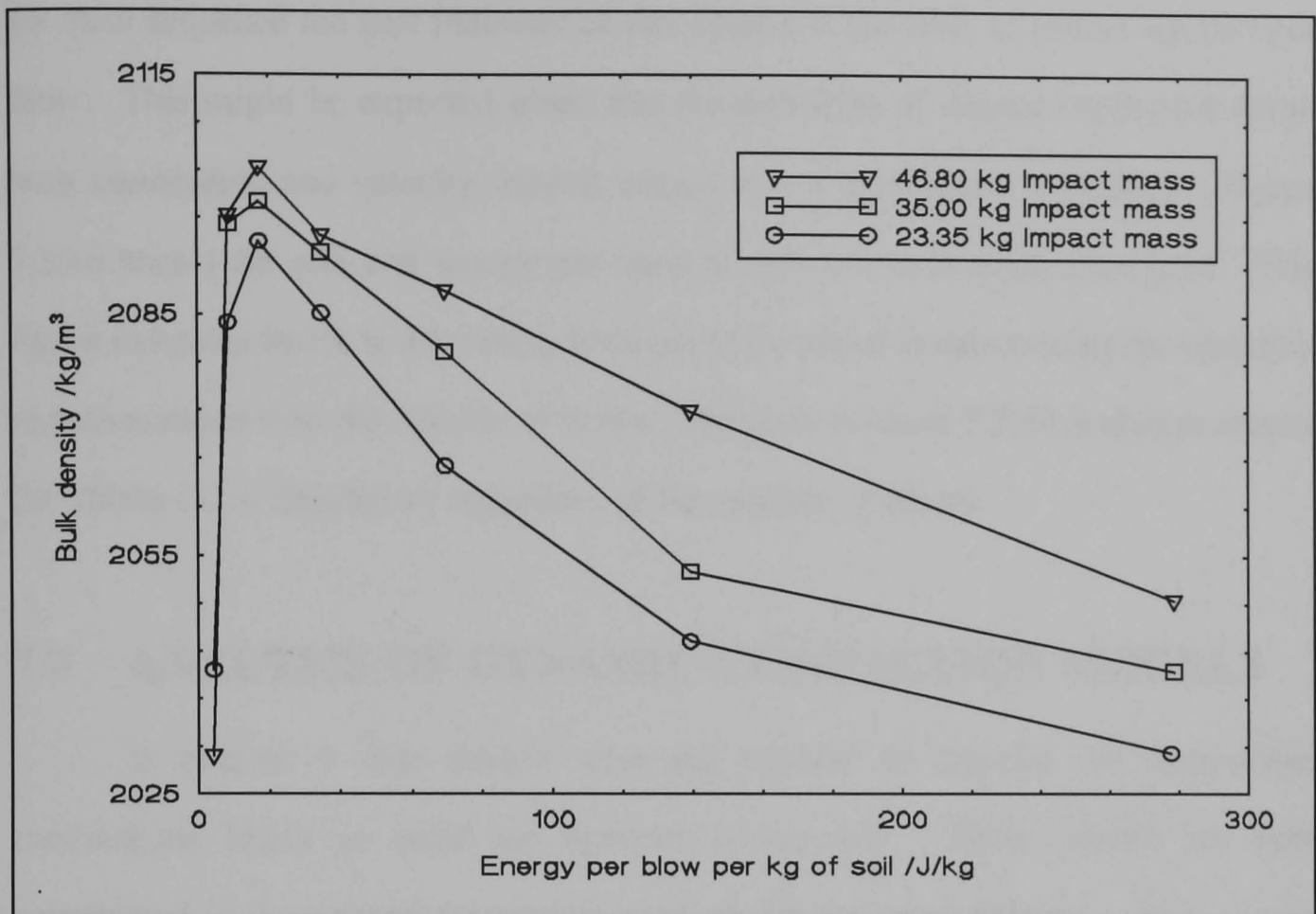

Figure 7.3.4a The effect of energy per blow per kg on bulk density. Each specimen received 279 J/kg, a total of 464 J.

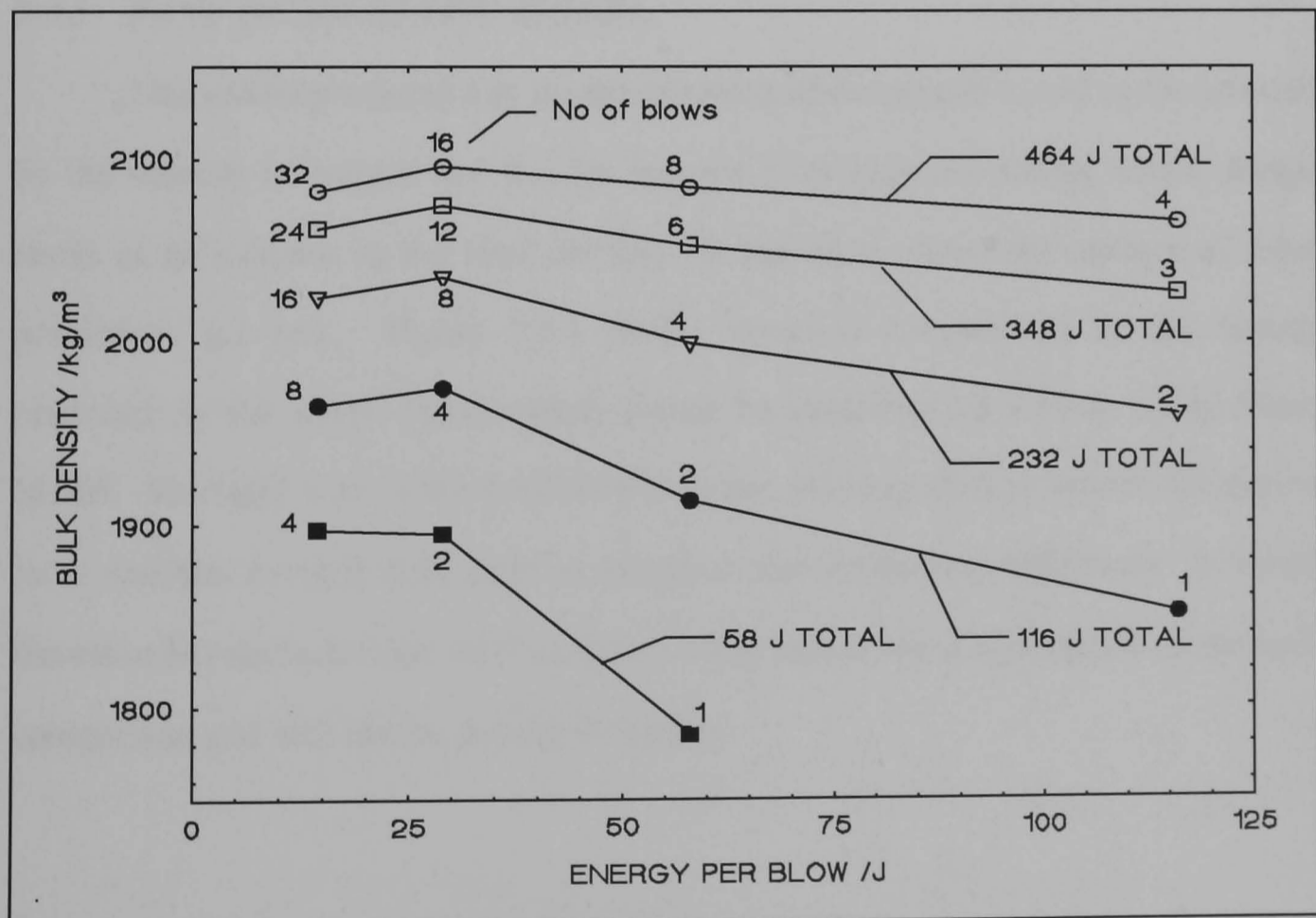

Figure 7.3.4b The effect of Joules per blow on bulk density at different levels of total energy.

16 blow sequence the best indicator of this change is the level of energy applied per blow. This might be expected given that the definition of kinetic energy combines both momentum and velocity; kinetic energy = $\frac{1}{2}$ x momentum x velocity. Figure 7.3.4b shows the effect of energy per blow at different total applied energies. This figure indicates that it is the energy level per blow which is determining the optimum sequence rather than the number of blows. The peak in figure 7.3.4b is always around 29 J/blow (17.4 J/kg/blow) regardless of the number of blows.

7.4 ANALYSIS OF DYNAMIC COMPACTION MODELS

In chapter 6 four models were put forward to describe the compaction mechanisms likely to occur on dynamic compaction. These models are now reexamined in the light of the experimental results discussed above.

7.4.1 FAST QUASI-STATIC MODEL

This model predicted that the densification of the sample would not be affected by the velocity of impact and that an increase in the applied energy would always result in an increase in the final density. It has been shown that neither of these predictions are true. Figure 7.3.1 clearly shows a discontinuity in the density produced by the single blows which cannot be explained by a faster Quasi-Static Model. Similarly it has been found that impactor velocity (differences in momentum for a constant energy) does have an effect on the compaction efficiency. It would therefore be concluded that the Fast Quasi-Static Model is not appropriate to dynamic compaction and will not be discussed further.

7.4.2 AIRLOCK MODEL

The Airlock Model predicted that for a given applied energy a low momentum (high velocity) impact would produce less densification than high momentum blow. If figure 7.1a is again examined it can be seen that for every sequence other than the 64 blow, this is true. For a given total energy and a given energy per blow the lower velocity (higher momentum) blow is more effective. For the very low velocity 64 blow sequence however this is reversed and contradicts the Airlock Model.

If figure 7.3.3c is again examined it can be seen that above the velocity of impact associated with the 29 J blows any increase in blow velocity results in a reduction of density. This is in agreement with the Airlock Model. However below the optimum blow energy any reduction in velocity also causes a marked drop in compacted density, where the Airlock Model would predict that such low velocities should be the most effective.

It would appear that at low impact velocities airlock is not a dominant factor in compaction although it may be at higher velocities, particularly at velocities greater than the optimum. However the Airlock Model cannot easily predict the presence of such a pronounced optimum without a complex interaction between the driving pressure gradient and the reduction in permeability.

To investigate the possibility of reduced permeability in the *upper* layers of the cylinder providing the basis for an airlock, three further cylinders were compacted in a modified mould. Three sheets of progressively finer steel mesh were placed between the mould and the mould base plate such that the mould base would allow the escape of air, without allowing the soil to escape, even if the upper layers became impermeable. These cylinders were subjected to a single 464 J compaction blow by the lightest mass and compared to the samples similarly compacted in the standard mould configuration.

A minor increase in density was found with the meshed samples and a marginal reduction in the severity of the flaw lines. However these observations were not sufficient to support a theory of airlock based solely on the reduction in permeability of the upper layers. If the upper layer impermeability theory had been correct it would be expected that a significant increase in density would occur when the lower layer was ventilated in this way, because the lowest layers of the cylinder would be the slowest to increase in permeability. Hence it would be expected that a significant additional volume of air could be expelled through the mould base.

As the effect was minor this would seem to support the compression wave theory which would allow the soil to become suddenly compressed as the compression wave passed through it. If the velocity of the compression wave was larger than the velocity of the air which was being expelled, the meshed mould base would have little effect other than on the region immediately next to it.

7.4.3 SOFT HYSTERIC SPRING

This model stated that as the velocity of impact was increased from near zero so the effect of friction would be reduced and a more uniform densification would occur. It predicted that for a given low energy per blow, a high velocity (low momentum) blow would be more effective than a low velocity one (high momentum). This has been shown to be the case for the 64 blow sequence where the higher velocity blow was more effective. However for all other sequences it is the lower velocity blow which is the more effective.

This model also predicted that a single high energy blow would be more effective than a number of lower energy blows. This has not proved correct and would indicate that this model too only provides a partial explanation of the mechanism and is only valid for very low velocity blows.

7.4.4 COMPRESSION WAVE MODEL

This model predicted that the Soft Hysterical Spring Model would operate until the velocity of impact was raised above a certain value, sufficient to produce a compression wave. In fact the hysterical model was only valid for very low energy blows (64 blow sequence) and failed before the optimum energy per blow was reached. However the existence of the optimum is indicative of a change occurring at this point and may therefore support the onset of a compression wave.

If the reduction in density at velocities greater than the optimum is a result of the formation of progressively stronger compression waves then it would be expected that for a given energy per blow a higher velocity blow would produce a more pronounced compression wave and hence be a less efficient method of compaction. This is in agreement with the observed results. The Compression Wave Model then provides a mechanism to explain the observed optimum and the reducing compaction efficiency seen at velocities greater than the optimum.

7.4.5 COMBINED MODEL

None of the above models can predict all of the observed results. However in combination they may provide a working model. Using very small blows the soil compaction is dominated by friction. The velocity of impact is too low for the airlock phenomenon to be significant. The soil may compress more uniformly than would be the case for quasi-static compression as the velocity of impact is sufficient to allow a fraction of the static friction to reduce to the lower dynamic friction value. Low momentum small blows are more effective than high momentum ones as their higher velocity allows a greater fraction of this static friction to reduce to the dynamic level (the Soft Hysterical Spring Model).

Between the 7 J and 29 J blow energies the increasing velocity of impact further reduces the effect of friction but at the same time the expulsion of air becomes

more significant to compaction. As the velocity of impact increases so to does the driving pressure gradient but at a lesser rate than the reduction of permeability. Although overall the compaction efficiency of the 14.5 J blow is greater than that of 7 J ones, it is now the lower velocity blow which is more efficient. This would indicate that a type of airlock phenomenon was becoming more significant but acting in conjunction with the soft hysteric spring effect.

The optimum compaction blow energy may be thought of as the point at which the velocity of impact, for a given impactor mass, is on the verge of producing a compression wave but falls just short. For this experimental configuration the optimum occurs at 29 J per blow (16 blow sequence or 17.4 J/kg/blow).

At energy levels per blow greater than the 29 J optimum the onset of a compression wave would be expected to greatly increase the difficulty in air expulsion. As the energy per blow increased the compression wave would form earlier in the compaction process and travel through the soil more quickly, progressively trapping a greater fraction of the entrained air. Once the compression wave had passed through to the bottom of the mould it would then be reflected back as a rarefaction, creating small tensile cracks as a result of the low tensile strength of the soil. These tensile cracks would then act as local channels of high permeability and allow the compressed entrained air to rapidly decompress, possibly enlarging the tensile cracks. This Combined Model may then be used to explain all aspects of the observed results. On the basis of such a model it would be expected that the near-zero velocity of quasi-static compaction would be inefficient as the dominating factor would be static friction.

Velocity has been used in this argument for clarity, however it should be noted that the velocity of impact does not define the optimum configuration irrespective of the impactor's mass, the optimum velocity changes for different mass impactors. It is the energy per blow which forms the more precise definition of the optimum

configuration, for a given total applied energy level. This Combined Model would predict that if a sufficiently wide range of momentum had been used for the experimental investigation, further gains in density would have been found with higher momentum impactors, applying 29 J per blow.

The density gain found by using progressively more massive impactors would continue until the velocity of impact had reduced sufficiently to allow the static/dynamic friction balance to become the more significant limiting factor. Once the static/dynamic friction balance had become significant any further increase in blow momentum would result in a reduction in the compacted density.

The flat peak of figure 7.1a suggests that the onset of any compression wave phenomenon is gradual. It is proposed in conclusion that the dynamic compaction process is the result of a complex interaction between the rate of air expulsion, the degree of frictional resistance offered by the soil and the point at which a compression wave may form.

For the cylindrical mould used in this investigation, the optimum level of energy per blow was found to be 29 J (16 blow sequence). The difference in strength resulting from 58 or 14.5 J blows (8 or 32 blow sequence) rather than 29 J is only 3% (based on the empirical relation derived in chapter 5). It could then be considered that for any practical implementation of dynamic compaction the optimum may be broadened to a range equivalent to 58 to 14.5 J per blow (8 to 32 blow sequence, 34.8 to 8.7 J/kg/blow) with little fall off in performance. Moreover the lowest compacted bulk density produced by blow configurations within the above range (2084 kg/m^3), is still significantly greater than the compacted density resulting from the quasi-static application of the same energy (2048 kg/m^3).

7.5 IMPLICATIONS FOR MACHINE DESIGNS FOR STANDARD-SIZE BLOCK COMPACTION

It has been shown that dynamic compaction is capable of producing soil-cement equivalent in density to that produced by quasi-static compaction. Moreover it has been found that dynamic compaction may produce equivalent density for a lower expenditure of energy.

This research was conducted on cylindrical samples and not on standard-size blocks. It was shown that quasi-static compaction of this size of cylinder to a specific density required 8 % less energy per unit of compacted volume than compaction of a standard-size block. It would therefore be expected that the energy per unit volume required to compact a standard-size block by impact would be higher than that required to compact a cylinder. However it seems that the mechanism which underlies impact compaction is not the same as that which governs quasi-static compaction, in which case it is not possible to predict the amount of additional energy which would be required. It is possible to predict the trends which would operate but not the actual optimum mass and velocity combination for standard-size block compaction. In particular the models which have been put forward to explain the dynamic compaction process do not allow for the effects of mould size and shape.

Compaction of a conventionally orientated standard-size block will increase the surface area which is impacted, compared to the cylinders used in the above experimental research, and hence change the energy intensity per unit area provided by a given level of energy per blow. The effects of such changes are not known. The above Combined Model discusses the optimum in terms of the velocity at which a compression wave is on the verge of forming, however it is the energy level per blow which is the common feature to define the optimum regardless of impactor mass (within the range tested). If the optimum energy level for the cylinder (29 joules per

blow) were to be applied to a standard-size block the energy intensity would drop from 3692 J/m^2 to 714 J/m^2 . This would be expected to reduce the density gain per blow, however if the energy intensity is scaled to allow for the additional impacted area, a figure of 150 joules per blow is found. Such an energy level would require a 50 kg mass (probably the largest which could be conveniently used for a manually operated machine) to be dropped from 0.3m and would impact the block with a velocity of 2.4 m/s. Although the energy intensity of such a blow would be equivalent to that for the compacted cylinder the impact velocity would be substantially higher. As discussed below it is likely that the expulsion of air would be a more significant constraint for standard-size compaction and hence any increase in blow velocity may result in a reduction in compaction efficiency.

The ratio of the impacting piston surface area to compacted block perimeter area might also be expected to affect the efficiency of compaction as this ratio will affect the area available through which the entrained air may be expelled and the distance which it would have to travel to reach a soil-mould interface. The piston area to perimeter area ratio is 0.472 for a standard-size block while it is 0.250 for the cylinders used above. This means that the cylinder has 1.89 times more perimeter area per unit of impacted surface area than the standard-size block (if the block is compacted in the conventional orientation). This might be expected to increase the significance of air expulsion for standard-size block compaction, any entrained air would have further to travel and a given volume of air would have to escape through a smaller area of perimeter.

If the expulsion of air were to prove a severe constraint to standard-size block compaction it might be suggested that end compaction be investigated. By applying the impact blow to the smallest face of the block the surface area to perimeter ratio would be reduced to 0.029 m. End compaction has not been successful for quasi-static compaction for two reasons. The fall off in density with distance from the

moving piston is too great, resulting in a large strength difference between the two ends of the block. The force required to eject the block would be higher as the surface area of the block in sliding contact with the mould is larger and the ejection force would have to be sustained for longer. Dynamic compaction does not suffer from as drastic a drop off in density with distance from the impacted face and it has been found that the force required for ejection is lower.

The information gained from this experimental investigation is not likely to be directly transferrable to standard-size block production. It has been shown that there is sufficient potential advantage to impact compaction to warrant further work, however it is likely that the values found in these experiments will only be valid for the dimensions of the compaction mould used.

For a given total applied energy there is an optimum energy level per blow and within the range tested a higher impact mass will produce a more dense sample. For standard-size compaction it would be suggested that an initial value be assigned to the cumulative total of applied energy, based on between 200 - 300 J/kg of soil. 200 J/kg should allow optimised impact compaction to produce block densities broadly equivalent to quasi-static compaction to 9 MPa. If energy levels significantly greater than 300 J/kg are required to produce density comparable to 9 MPa quasi-static compaction, this would indicate that impact compaction is not efficient for standard-size block compaction. Once the total energy is set the largest convenient mass should be selected and a process of optimisation should be conducted where the optimum energy level per blow should be established by experimental trial.

7.6 CONCLUSIONS CONCERNING CHAPTER SEVEN

Although no direct recommendations may be made as to the optimum configuration for standard-size block compaction, a significant body of evidence has

been gathered to support the case for further investigation of dynamic compaction of standard-size blocks.

Dynamic compaction to a density equivalent to that of a 9 MPa quasi-statically compacted cylinder was found to require 43 % less energy. Optimised dynamic compaction has been used to produce cylinders which are 24 % stronger than their equivalent density, quasi-statically compacted, counterparts (a larger strength gain would have been apparent if a heavier impactor had been used). Moreover it was estimated that these factors would combine to significantly reduce the energy required for impact compaction to between 25 and 50% of that required for quasi-static compaction. This would apparently support the TRRL finding that impact compaction does produce a greater increase in density at depth than is possible with quasi-static compaction.

Four models were put forward to describe the compaction mechanisms likely to occur on dynamic compaction. The first model, Fast Quasi-Static compaction was shown to be inadequate, impact compaction is not simply a "faster" version of quasi-static compaction. The three remaining compaction models were each able to contribute an explanation for a particular aspect of the compaction process. By amalgamating these three models a simple working model (the Combined model) was formed which was able to explain the effects of impact velocity, momentum and energy per blow. Impact compaction is the result of a complex interaction between the rate of air expulsion, the degree of frictional resistance offered by the soil and the point at which a compression wave may form. The Combined model does not allow the magnitudes of effects to be predicted from a given change in variable but does allow the direction of change to be predicted.

The tests indicate that there is an optimum number of blows between which the total impacting energy should be shared. Too few (and therefore too large) blows result in the generation of damaging negative pressure shock waves. Too many (too

small) blows result in poor densification. The range of efficient blow energies was 15 to 60 J per kg of the specific soil being compressed (*soil-A*). With blows of an efficient size a large mass travelling more slowly performed better than a low mass travelling faster.

The combination of a reduction in the energy required to produce a given density, with the increased strength found for that density, must warrant a further investigation of such dynamic methods of compaction. Optimised impact apparently needs between 25 and 50% of the energy required for quasi-static compaction to achieve the same block strength. It seems probable that blows of a suitable energy and momentum, to efficiently compress a standard-size block to a high density, could be obtained in a machine of realistic size and weight.

Even if the energy and compressive strength benefits seen with this type of cylindrical specimen are reduced or nullified when compacting a standard-size block, the potential saving in machine cost for dynamic compaction, compared to high pressure compaction by quasi-static machines such as the Brepack, would appear to be sufficient justification in itself (see simple economic analysis chapter 5).

CHAPTER 8

COMPUTER SIMULATION OF CONFINED DYNAMIC SOIL COMPACTION

8.1 INTRODUCTION

A computer simulation was produced to investigate the dynamic compaction process further by and attempting to identify any gross change in compaction which could be indicative of the transition from uniform spring compression to a compression-wave phenomenon (see compression wave model chapter 7). The simulation tried to verify the spring and compression wave models by examining how a set of massless springs connecting small finite masses would behave when subject to various magnitude impact blows. This simulation was not intended to exactly reproduce all aspects of dynamic compaction but rather to investigate the build-up of a compression wave front under conditions of high energy impact. It was used as a tool to determine whether such a compression wave could develop when the confined soil was subjected to high energy impact blows.

It was expected that at low levels of energy per blow simple spring compression would be observed, whereby all sections of the spring/mass system would move in unison, following a short initiation lag period. All elements of the system would initially move in the same direction, the top element having the same velocity

as the impactor. Compression would continue until the velocity of the impactor had been reduced to zero, whereupon the segments would uniformly decompress in a similar manner to that seen during compression.

At high levels of energy it was expected that a compression wave might be observed. This would be signified by spring/mass elements accelerating above the velocity of the impact mass and a region of over-compressed material moving ahead of the impact mass.

The program was developed in a number of phases, from a simple model which used a single spring constant for all stages of compaction and relaxation, to a more complex model which could select the appropriate value for the "plastic" (see below) spring constant by considering both the current forces acting and the previous history of each element of the spring. The simple programme was used to test and develop the simulation logic, while the more complex model more accurately replicated the compression by including hysteresis.

8.2 SIMULATION LOGIC

The simulation was a finite element programme which modelled the progress of the compaction process by stepping a very small increment of time and updating the relevant parameters of each element of the modelled soil in succession, starting with the impactor and working down through the soil. The soil was treated as 20 discrete masses, separated by 21 massless springs (see figure 8.2a). Each mass element was 83.8g, giving a total soil mass of 1.666kg. The spring constants were found by quasi-statically compressing a sample of soil in the impact mould, using a Tensometer type E machine to record both the load applied to the soil and its deflection.

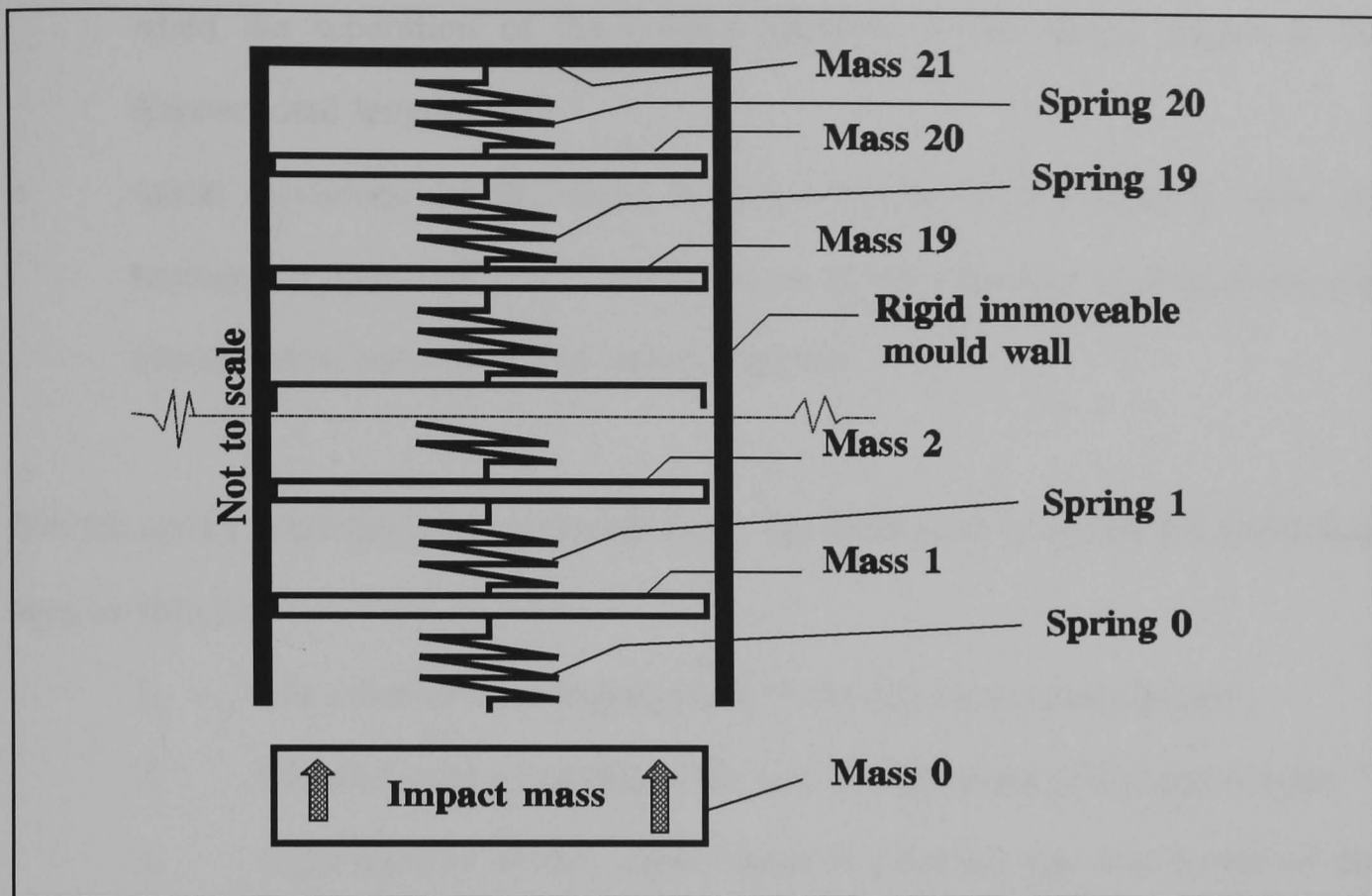

Figure 8.2a Schematic diagram indicating the spring/mass orientation used during the simulation

System constraints:

- Every spring lies between two masses which are equal except for the first spring (where the upper mass is the impactor mass) and the last spring (where the lower mass is infinite).
- As the springs are massless the force they exert on the mass below them is equal (but of opposite sign) to the force they exert on the mass above them. This force is a non-linear function of spring length. (See hysteresis discussion below).
- When springs are attached to masses, the velocity and displacement of the spring ends are those of the adjacent masses. Once one end of a spring is disconnected it retains its length at the time of disconnection. The displacement of the other end is determined from the velocity and acceleration of the adjacent mass to which it remains connected. Reconnection occurs

when the separation of the masses adjacent to the spring returns to its disconnected length.

- Initial conditions are all masses stationary except for the impactor mass, all springs are preloaded by the static weight of the stationary masses above, the impact mass has a specified impact velocity.

For the spring currently being considered, the sequence used to update the simulation was as follows:

1. Old velocity and displacement of the adjacent masses known
2. Velocity used to calculate the new displacement of the upper mass
3. Displacement of the masses used to calculate the new length of the spring
4. Length of the spring used to calculate the force in the spring
5. Force in the spring used to calculate the forces on both masses
6. Forces on the masses used to calculate the acceleration of the masses
7. Acceleration of the masses used to calculate the new velocity of the masses
8. System variables updated for the spring and mass pair under consideration
9. The processes 1 to 8 are repeated until the last spring is considered, whereupon time is incremented by one interval and process repeated until predetermined run time has elapsed.

A full listing of the final uncompiled Fortran program is given in appendix N. The final development of the program tested the condition of each spring element to determine whether it was compressing or expanding and assigned a value for the spring constant, depending on its current state of compression and its previous

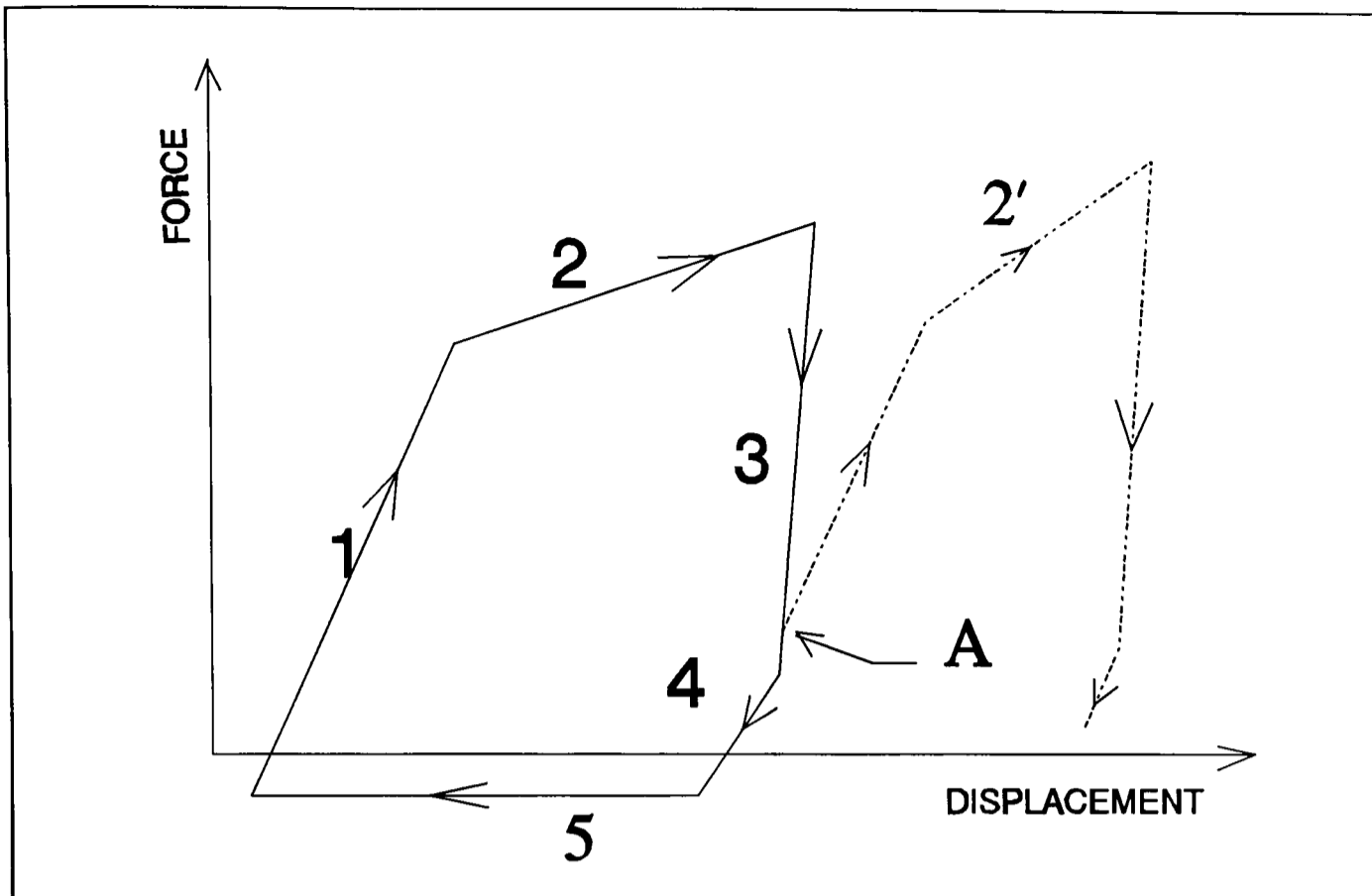

Figure 8.2b Schematic representation of the spring constants used to simulate hysteresis. The dotted extension beginning at point A shows how the hysteresis loop may progress during compaction.

maximum compression. In this way a hysteresis loop was constructed to simulate energy loss and therefore damping. This damping was effectively sequence dependant while the actual soil system damping would be expected to be speed dependant. Although not strictly correct it was assumed that this form of damping would approximate that occurring in reality.

Figure 8.2b shows a schematic representation of the relation of the different spring constants forming a hysteresis loop, numbered 1 to 5. This pattern of variation in spring constant was found during the experimental quasi-static compression of the soil sample and agrees with the soil behaviour seen under cyclic loading reported by O'Reilly & Brown (1991) among others. Number one (1) represents an elastic compression and is assumed to hold until the magnitude of force is approximately

75% of the historical maximum¹. Number two (2) represents a softer spring equivalent to plastic compression and applies when the magnitude of the force is greater than 75% of the historical maximum. Number three (3) is a constant representing stiff relaxation which operates until the magnitude of force is less than 5% of the most recent maximum². While number four (4) is a softer constant which operates until the force is less than -1% of the historical maximum. Below -1% of the historical maximum the spring is assumed to have snapped (represented as constant 5). The dotted extension shown in figure 8.2 indicates how the hysteresis loop moves as the compaction progresses. At point A the spring ceases to reduce and begins to increase as a result of interactions with other spring/mass elements. This increase is governed by spring constant 1 until it reaches 75% of the historical maximum whereupon the constant is updated to the plastic spring constant (2'). This diagram indicates the action of the final simulation programme where the value of spring constant 2 was updated to 2' to reflect the increasing stiffness of the soil as the compaction progresses.

8.3 RESULTS OF SIMULATION

The final version of the simulation programme used a fifth order polynomial expression to allow the "plastic" spring constant to be predicted for each spring segment, at each time increment. With this continuously updated spring constant it was possible to observe two apparently distinct compaction process, which may represent the change from the soft hysteretic spring model to the compression wave model of operation (see chapter 6).

¹ The largest value of force so far experienced by this spring since the start of the simulation.

² The largest value of force experienced in the most recent cycle.

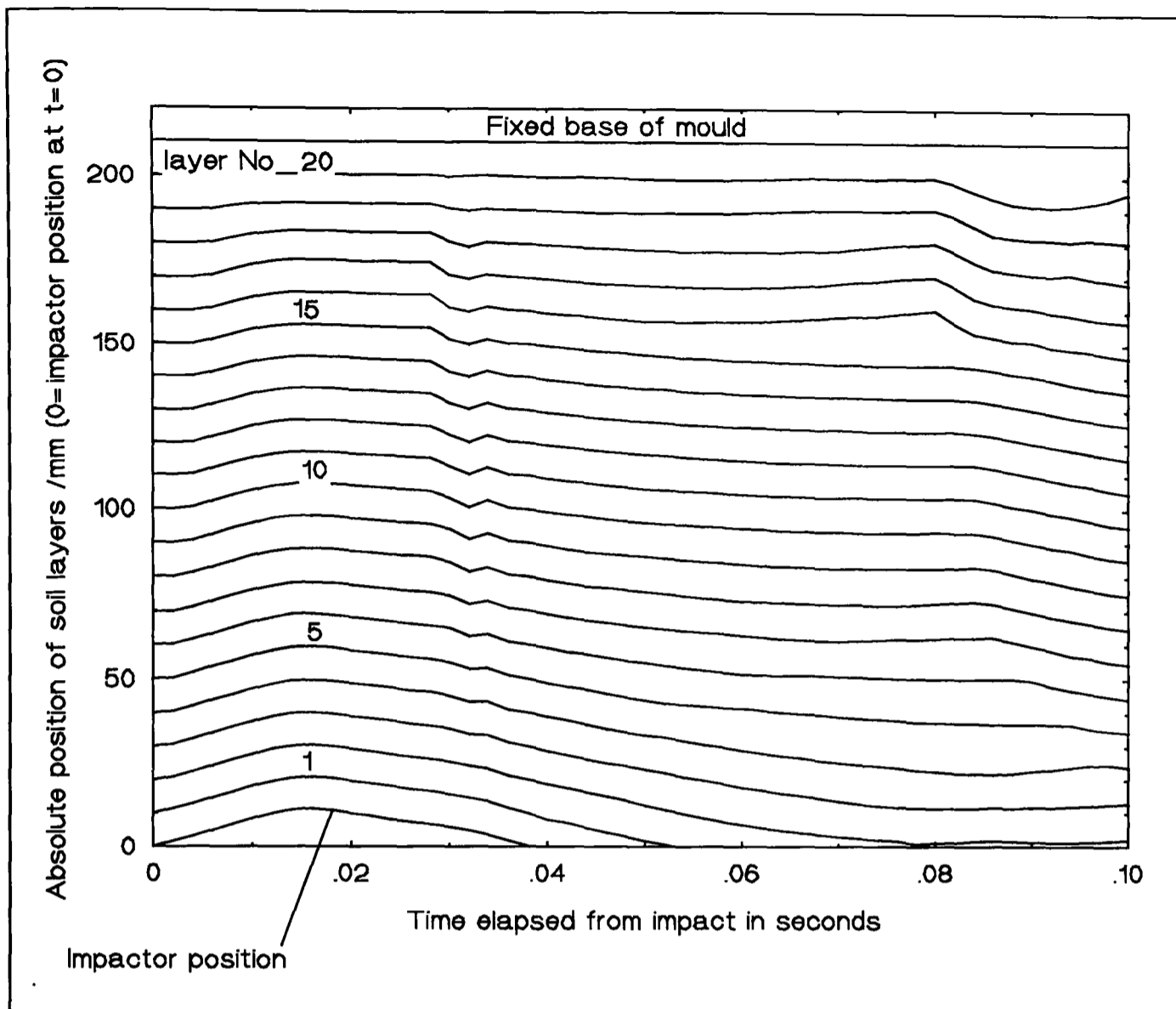

Figure 8.3a Absolute layer displacement against time for a single blow from the 64 blow sequence of the 23.35 kg impactor mass (velocity of impact = 0.79 m/s, energy of impact = 7.3 J).

Figure 8.3a shows a plot of the absolute displacement of each soil segment against time from the moment of impact for a quite low (0.79 m/s) velocity blow of the 23.35 kg impactor. This plot shows a near uniform compression and in particular the lag period (the length of time for which segment $n+1$ remains motionless after segment n has begun to move) remains constant for all of the mass segments. Figure 8.3b shows the result of a much faster (6.3 m/s) velocity blow. In this case the compression is clearly not uniform. The lag period reduces dramatically from the soil layers 0 to 5 (The computer plot is the inverse of the practical apparatus in that the impactor is effectively rising from below. 0 is the impactor position at $t = 0$) to layers 15 to 20. The near vertical progression of the lag front in layers 15 to 20 appears to

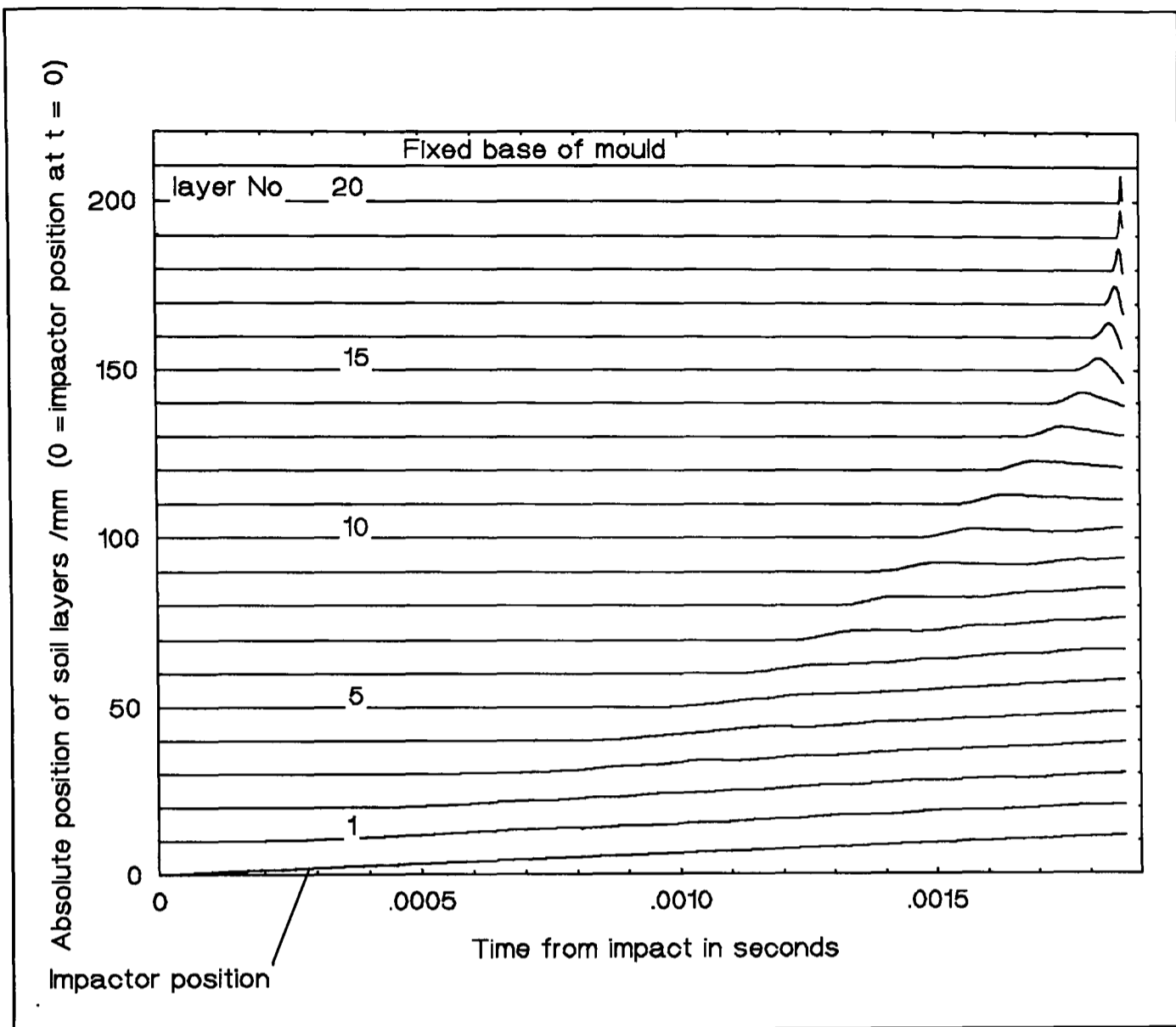

Figure 8.3b Absolute layer displacement against time for a single blow from the 1 blow sequence of the 23.35 kg impactor mass. (velocity of impact = 6.3 m/s, energy of impact = 464 J)

indicate the formation of a compression wave. The mass segments in this near vertical lag phase accelerate to a velocity greater than that of the impactor mass, the necessary condition for a compression wave. The simulation was not able to show any subsequent decompression trends for the high velocity impact as the forces generated in arresting and reversing this motion rapidly became too large to be accommodated by the software architecture, even with a 10^{-10} second interval.

Figure 8.3a also shows what may be interpreted as the formation of a tensile crack. If this figure is examined at $t = 0.08$ it can be seen that at a height of approximately 150 mm the separation between adjacent masses is significantly greater than the spring free length, indicating that the spring has broken in tension. This too

would be compatible with the observations recorded during actual soil compaction and would tend to confirm that the flaws seen with real high energy impacts are the result of the enlargement of these cracks by the escape of trapped compressed air.

Computer simulation of dynamic compaction was not as successful as was hoped. The simulation was found to be highly dependent both on the values used for the spring constants and the points at which the constants were changed. Figures 8.3a and 8.3b are the product of many iterative simulations, changing the values used for the constants and the positions of changeover. Each of these iterations used a value determined from the experimental quasi-static compression tests, however quasi-static compression produced many possible values for each of the spring constants, depending on both the currently experienced confining pressure and the historical path which lead to this pressure. The difficulty with a simulation such as this is justifying the use of a particular set of spring constants. For example a completely different set of spring constants may be found by quasi-statically compressing a sample to 1, 2 or 4 MPa. Similarly the spring constants found at any compression level depended on the previous history of that sample, namely whether it had been compacted directly to a certain pressure in a single cycle or had undergone any prior applied pressure cycling.

Because of the above mentioned uncertainties this simulation could not be used to determine the conditions governing the changeover from uniform to compression-wave compaction, as was initially hoped. Any values determined would have been dependant on the assumptions of the simulation rather than reflecting the precise soil behaviour. Instead the simulation was used to search for gross changes in compaction mechanism.

In conclusion the simulation has shown, in gross terms, that near uniform compression occurs at low impact energies and it has produced indications that a compression wave type phenomenon occurs at high energies. Moreover it has shown

that tensile fracture on decompression is also possible as predicted by the combined model in chapter 7. It is not recommended that computer simulation be used to study dynamic compaction process. The variations in soil properties during compaction are too large to be approximated by constants and are neither simple to record in practice nor may they be easily predicted.

CHAPTER 9

CONCLUSIONS AND FURTHER WORK

9.1 CONCLUSIONS CONCERNING SOIL STABILISATION

Part A of this thesis served three roles:

- It presented a broad overview of the processes of soil stabilisation, acting as an introduction to cement-based stabilisation and providing a theoretical background against which soil strength and stabilisation procedures may be better understood.
- It highlighted the complexity which underlies soil stabilisation, as a result of the near infinite variation in soil composition, explaining how a soil's grading, plasticity and clay type as well as compaction pressure, moisture and stabiliser content affect the compacted block density, its strength on demoulding (handleability) and its final cured strength. It explained the importance of selecting an appropriate soil and why the definition of an appropriate soil depends on the production equipment used and the properties required of the final cured block.

- It examined the field and laboratory soil-testing procedures previously published by other authors, highlighting methodological flaws and presenting corrected soil-testing procedures which are more reliable. It also indicated how to best combine different soil tests to enable a fast efficient discrimination of soil properties without undue repetition.

The literature review conducted at the outset of this research found that the process of soil stabilisation is not fully understood and that models or explanations of the various process are rather under-reported. Chapter 2 of Part A described the mechanism responsible for the dry strength of unstabilised soil and how such an unstabilised soil is adversely affected by exposure to water. It also described some of the more common methods used to improve the performance of soil walling, including explanations of how these methods provide improved performance in the light of the unstabilised-soil strength mechanism. It indicated which stabilisation methods may be used together and which methods are most suitable for which soil type.

Given that the most important variable in soil-cement walling is the type of soil used, it can be seen that a thorough, accurate soil testing programme is essential if mass trial and error testing is to be minimised. Chapter 3 dealt specifically with soil for soil-cement block production. It presented an explanation of how a soil's grading and plasticity affects stabilisation and also how both the degree of compaction applied and the moisture content used interact with these properties. It surveyed the criteria presented by other authors to define a "soil suitable for cement-based stabilisation", concluding that although certain broad criteria may be given (the soil should be well graded containing around 75% sand and gravel and 25% fines of which more than 10% should be clay) the wide variety of soil both in terms of the grading and clay type does not allow one specific optimum to be presented, particularly so as

any definition of an optimum soil would depend on the degree of compaction used during block pressing.

Soil selection affects the entire production process, from the amount of stabiliser required to the handleability of the freshly ejected block and its final compressive strength and durability. The soil testing procedures reported by other authors were carefully examined for accuracy and were found to be deficient in a number of areas. The specific errors in the reported experimental methods were corrected and explanations given as to why the corrections had been made (corrected testing procedures are reported in appendices B and C). It is most important that the tests which are used are accurate, misclassification of a soil may lead to poor quality blocks and increased stabiliser quantities.

9.2 QUASI-STATIC COMPACTION

Potential improvements to the quasi-static moulding process

Part B of this thesis examined the process of quasi-static compaction of soil-cement blocks. It appeared that the quasi-static compaction route had historically been followed as a result of the early research carried out with the Cinva Ram, a simple manually-operated machine which can apply up to 2 MPa compaction pressure. When compacting to low pressures a simple toggle lever can apply the required force. However if high pressure compaction (10 MPa) is required then a hydraulic system must be used, greatly increasing the cost of the machine (typically a ten fold increase).

Lunt (1980) had shown that for a given quantity of stabiliser increasing compaction pressure results in stronger cured blocks. This increase in cured strength must be a result of improved densification of the soil. If it were possible to improve the internal pressure transmission efficiency by reducing mould-wall friction, tapering the mould, using pressure cycling or double-sided compaction, then the strength

benefit of increased density would become available without requiring higher compaction pressures (Lunt recommends compaction pressures in the range 8-16 MPa).

The effects of varying the above mentioned moulding parameters were examined, both to identify the mechanisms acting during compaction and to establish whether a significant improvement in density would be possible through means other than by increasing the compaction pressure.

A standard compaction process was defined and examined in detail, being subsequently used as a datum against which the effect of variations in moulding parameters were judged and to evaluate the postulated theoretical models.

The standard compaction process was found to allow the transmission of 69 % of the applied top pressure to the mould base and 36, 36 and 29 % to the upper, central and lower mould-wall regions respectively. The transmitted pressure was seen to rise linearly with increasing top pressure but to display a strong hysteresis pattern on unloading, although there was negligible residual bottom pressure when the top pressure was reduced to zero. The top pressure had to drop by 25, 50 and 75 % (lag fractions) respectively before there was a noticeable fall in the upper, central and lower lateral mould-wall pressures. Again on final removal of the top pressure all the side pressures fell to approximately zero.

Mould-wall friction was found to have a significant effect on compacted block density and the magnitude of the transmitted pressure. Reducing the mould-wall friction by lubrication increased the pressure transmitted to the mould base by 14 % (gain increasing from 69 % to 76 %) and the upper and lower lateral mould-wall pressures by 17 and 29 % respectively. The experimental method used to reduce the wall friction could not be used in actual block production as the plastic rucked into the block producing partially flawed blocks. However this experiment did reaffirm the significance of friction and hence it is strongly recommended that the mould

should be as smooth as possible, in particular that any machining marks should be orientated parallel to the direction of movement of the compacting piston.

It was found that although tapering the mould walls improved the ease with which a block could be ejected it did not improve the block density. Thus mould-wall taper is not recommended for incorporation in block presses as the awkward block shapes would unnecessarily complicate construction.

Pressure cycling was found to increase block density. The degree of improvement depended on the magnitude of the pressure cycle. Partial pressure cycling had no effect on lower soil layers unless the lower bound of the cycle was less than the lag fraction of the applied top pressure for that area (see above). Full pressure cycling did have a beneficial effect on all areas of the block, four full 10 MPa pressure cycles produced a 2.5% increase in compacted density (equivalent to a 13.5 % increase in cured compressive strength on the basis of the pressure-cement-strength relation described in chapter 5). However it was noted that pressure cycling is not possible with a fixed volume type press and could reduce the daily block output of a hydraulic (Brepack) machine by 40 %. It is not recommended that pressure cycling be used with manual block pressing machinery.

True double-sided compaction (an exact equality of top and bottom applied pressures rising and falling in unison) was not achieved as might be the case for mechanically linked pistons. In the "floating mould" configuration used the base pressure was only 81% of the top pressure compared to the 100% of perfect double-sided compaction and 69% for standard single-sided compaction, the 7-day cured strength of blocks compacted in this way was only 7 % greater than that for the standard process. If perfect double-sided compaction had been achieved it would be expected that no more than a 15-20 % increase in 7-day strength would have been found, relative to standard compaction. Given this small increase in strength it

appears likely that the additional mechanical complexity required to apply double-sided compaction would not be warranted.

In summary it was found that only minor improvements in compacted density may be obtained through improving the quasi-static compaction method and any such improvements other than minimising mould friction would be likely to increase the cost of a machine significantly. The pressure transmitted to the mould walls during compaction was found to be significantly less than the applied top pressure and unlikely to ever exceed 50 % of it. Therefore less material could potentially be used in the mould walls as hydrostatic conditions do not occur.

Theoretical quasi-static compaction mechanisms

Five theoretical models were put forward to describe the condition of the soil during quasi-static compaction, a Simple Hydrostatic Model, a Pipe Flow Model, a Solid Model (based on Poisson Ratio), a Frictional Poisson Flow Model (a combination of the pipe flow and solid models) and an Effective-Pressure Model. None of these models were found capable of explaining all of the phenomena observed during the experimental research programme, although some of them did explain specific aspects.

Hydrostatic conditions were never observed regardless of the moulding configuration used and hence the Simple Hydrostatic Model was dismissed. Similarly the pipe flow model was found inadequate. Although it did predict a fall in mould-wall pressure with distance from the compacting piston, no sign of pressure equalisation was found, indicating that the soil may not be described as a fluid at the end of the compaction process and moreover the pattern of lagged pressure fall on decompression was not compatible with the decompression of a fluid.

The Solid Model incorrectly predicted that a uniform mould side-wall pressure distribution should be found and that the pressure applied to the top of the mould

should be transmitted to the base of the mould undiminished. On decompression it predicted a uniform reduction in mould-wall lateral pressures rather than the lag pattern observed. Hence this model too was considered incompatible with the recorded results.

The Frictional Poisson Flow Model correctly predicted the reduction in the pressure transmitted to the mould base and the reduction in lateral mould-wall pressure with distance from the compacting piston. Moreover this model predicted the lag pattern seen in decompression and the limited effect of partial top pressure cycling (cycling down from full pressure to some intermediate pressure and back to full pressure). However it could not explain the pattern of reduction in the *upper and lower* lateral mould-wall pressures (while the central lateral pressure dropped only slightly) seen on full pressure cycling.

The Effective-Pressure Model could predict the pattern of lateral and base mould-wall pressures seen on compression but could not predict the lag pattern seen on decompression or the pattern seen on pressure cycling.

It was concluded that confined soil compaction cannot be exactly described by any of the models presented. In particular the pattern of reduction in lateral mould side-wall pressure seen on full pressure cycling could not be adequately explained. The reduction in mould base pressure relative to the applied top pressure, the fall in lateral mould-wall pressure with distance from the compacting piston and the 15% reduction in the base region's compressive strength compared to the top (for standard single-sided compaction) were assumed to be indicative of frictional wall shear forces. It would appear that highly complex non-linear phenomena occur during compaction, involving frictional, effective pressure and Poisson-type arguments.

Economics of quasi-static compaction

The pressure-cement-strength relation presented in chapter 5 refuted Lunt's claim that very high pressure compaction offers cost savings. It indicated that the cured compressive strength of a sample was more dependant on cement content than compaction pressure; a doubling of cement content produced an increase of 135 % in compressive strength while a doubling of the applied compaction pressure produced only a 25 % increase. An economic investigation to determine the cost of blocks produced by high and low pressure established that the savings in cement associated with increased compaction pressure were outweighed, primarily by the increased machine cost. However, in regions where the cost of a 50 kg bag of cement was significantly higher than the daily wage rate, high pressure compaction was less disadvantaged. In every case examined, high pressure compaction with less stabiliser was the most expensive, varying between 19 and 46 % more expensive for the 1.4 MPa strength standard and 9 and 24 % more expensive for the 2.8 MPa strength standard.

Based on this economic analysis it was established that a machine capable of high compaction costing in the region of £1000-£1500 (relative to £400 for a Cinva Ram) would allow blocks to be produced at roughly the same cost as those produced by low pressure compaction.

"Hidden" benefits of high pressure compaction

A number of advantages were found using high pressure compaction, in addition to the saving in stabiliser costs. It was not possible to reliably value these advantages and hence they were not included in the economic analysis.

It was found that a block compacted to 9.7 MPa was 2.4 times stronger on ejection from the mould than one compacted to 2 MPa. This additional green strength would allow a wider variety of soil (lower plasticity soils) to be stabilised and

decrease the block breakage rate on ejection and transportation to the curing area. Moreover increased green strength would allow more efficient stack curing which would significantly reduce the area required for curing blocks, saving the manufacturer the cost of additional covering material/structures. Furthermore the increased volume to surface area ratio of a larger stack would reduce the tendency for the blocks to prematurely dry out. Sutcliff's work (once re-analysed) also indicated, that for a given (well-cured) strength, a block compacted to higher pressure will display a marginally increased durability. The scratch tests conducted to assess the susceptibility of blocks to poor curing also indicated that compaction to higher pressure is marginally less susceptible to poor curing.

Each of these "hidden" benefits was minor, however when considered together there appears to be a significant advantage to high pressure compaction beyond simply a saving in stabiliser costs.

Overall conclusions concerning quasi-static compaction

It may be concluded that the mechanisms which govern quasi-static compaction are highly complex and non-linear. The soil does not reach a hydrostatic state during compression and the mould walls are unlikely to ever experience more than 50% of the applied top pressure. Friction is a significant factor, causing a 15% loss of strength in the base regions of the block, and should be minimised wherever possible by ensuring smooth mould walls. For the soil used in this research, compaction to high pressure by conventional quasi-static machines is not economic due to the high capital cost of such machines. Only marginal improvements to the quasi-static compaction process are possible through moulding refinements and the most significant of these, double-sided compaction, would entail increased machine costs. There are potential advantages to high pressure compaction, however these advantages are not justified unless the price of high pressure compaction equipment can be

significantly reduced, from £4000 to £1000-£1500. It appears unlikely that any high pressure quasi-static machine could be produced for this price.

9.3 DYNAMIC COMPACTION

Dynamic compaction was investigated as the method of compaction most likely to produce densities equivalent to those resulting from high pressure quasi-static compaction, without requiring such costly machines. The literature review had also indicated that dynamic compaction may be capable of producing a more uniform soil densification, in particular it may result in higher density at depth than quasi-static compaction.

Impact justified as an alternative to quasi-static compaction

The dynamic experimentation used 100mm diameter cylinders rather than standard-size blocks, due to experimental constraints. The energy which was applied to these cylinders by impact was calculated from that required to compact a standard-size block to 10 MPa. It was found that this cylinder size required only 8 % less energy to experience a quasi-static compaction pressure of 10 MPa than a standard-size block. Thus it was assumed that the results found for the cylindrical mould would be broadly representative of any trends exhibited by standard-size block compaction.

The results presented in Chapter 7 have shown that compaction by impact is more efficient than quasi-static compaction for the cylindrical mould used. Optimised impact produced density equivalent to quasi-static compaction while requiring 43 % less energy and for a given density was found to produce cylinders which were 24 % stronger. In combination, these factors could result in a 50-75 % overall saving in the energy required to achieve a given compressive strength, for impact compaction

compared to quasi-static compaction. The additional strength seen with impact, for a given density, has been assumed to be a result of improved uniformity of compaction as all experimental parameters other than the mechanism of compaction were identical to those used during quasi-static compaction. This is compatible with the increased density seen at depth with dynamic compaction of unconfined soil, as reported by the TRRL.

Modelling of impact compaction mechanisms

In order to establish a better understanding of the mechanisms acting during dynamic compaction, the experimental configuration used was designed to allow the effects of kinetic energy and momentum per blow to be investigated and compared with the theoretical models presented in Chapter 6. It was found that the Fast Quasi-static Model was inadequate, since a higher applied impact energy did not necessarily result in increased density. The remaining three models were each able to explain certain aspects of the observed behaviour and amalgamated to form the combined model.

The Airlock Model which assumed variable soil permeability was found to be compatible with the recorded result at energies per blow greater than 4.4 J/kg. However when the base of the mould was modified to increase the permeability of the lower regions of the cylinder, to test the theory of upper soil-layer impermeability, only a small increase in compacted density was found. This indicated that the phenomenon was more complex than simply a reduction in upper layer permeability. Moreover a reversal of the velocity trend was seen at very low energies per blow, a higher velocity blow then being more effective. This model alone was not able to explain the existence of an optimum without a complex interaction between the driving pressure gradient and reduction in permeability.

The Soft Hysteric Spring Model was found to be compatible with the pattern of densification seen at very low energies per blow. However at all energies per blow

greater than the lowest used (4.4 J/kg/blow) it was found to be partially incompatible. Although as the energy per blow increased so did the compacted density, above 4.4 J/kg/blow it was the slower velocity blow which was more effective (for a given energy per blow). This suggests that an Airlock-type phenomenon may be acting in conjunction with the Soft Hysteric Spring Model.

The Compression Wave Model was able to predict the existence of an optimum blow sequence, if the onset of a compression wave could be considered to be detrimental to compaction. It has been assumed that when a compression wave forms the speed of propagation of such a wave is much higher than the speed of uniform compaction. This increased speed of compaction then reduces the time available for any entrained air to escape, trapping and compressing the air in situ rather than expelling it. Both the negligible increase in density seen with the mesh-based mould and the flawed cylinders resulting from very high energy blows support this model.

The computer simulation described in chapter 8 was able to demonstrate both the near uniform compression proposed for low energy impact (Soft Hysteric Spring Model) and the shock wave-type compression (Compression Wave Model) proposed to occur at high impact energies. The simulation was a gross simplification of the system, precise modelling of the compaction process was not possible as the change in soil parameters depended on both the current state and the previous local history of the soil. The method used to determine the simulation spring constants, quasi-static compaction, was not truly compatible with the dynamic system which was being simulated. A more thorough determination of these parameters during dynamic compaction would have required highly sophisticated instrumentation which was not considered justified.

The final model presented in chapter 7, the Combined Model, amalgamated the compatible factors from the Airlock, Spring and Compression Wave Models. It allows the compaction process to be understood but does not allow precise predictions to be

made. Below the optimum value of energy per blow the Soft Hysteric Spring and Airlock Models interact. At very low energies per blow airlock is not significant and a higher velocity blow is more effective, at higher energies per blow airlock becomes more significant and lower velocity blows are more effective. At and above the level of energy per blow sufficient to cause a compression wave, the trapping of entrained air causes reduced density and decompression flaws. The optimum energy level per blow is defined as that just below the compression-wave threshold.

Optimisation and machine implications for impact compaction

It was found in practice that the optimum energy per blow was not highly critical, a relatively flat characteristic was found between energies per blow of 14.5 and 58 J (8.7 J/kg and 34.8 J/kg respectively). The difference in compacted density resulting from these values equated to less than a 3% variation in predicted compressive strength. Moreover the difference in density found by using a 46.8 kg impactor rather than a 23.4kg impactor was similarly limited to less than 3% at the optimum energy. This tolerance around the optimum would be expected with repeated equal-size blows as the occurrence of a compression wave is dependant on the density of the soil being impacted as well as the applied energy. This is useful for machine design as it allows a range of energies per blow and number of blows to be used without a serious adverse effect on compacted density resulting. Moreover further improvements in density for a given applied energy would be possible by using blows of progressively increasing size, however this would lead to more complex and hence more costly machines.

For the initial design of standard-size block compaction equipment it is suggested that between 200-300 J/kg be applied. However if the energy savings found when compacting cylinders is also found with standard-size blocks, this energy may be reduced accordingly for production equipment. Since it has not been possible to

predict the effect of mould shape on impact compaction, the actual energy required to compact a standard-size block should be determined by experimentation, as should the best values for impactor mass, drop height and number of blows. As a starting point the optimum value of 17.4 J/kg/blow, found for the cylindrical specimens produced for this thesis, is recommended.

It was noted in chapter 7 that in general when operating near to the optimum energy, a heavier impactor will be more efficient because of its lower velocity, hence any standard-size compaction machines should aim to use the largest practicable impactor mass. However maximising impactor weight should not be followed to extremes since if the velocity falls too low (in the limit quasi-static compaction) then although the airlock phenomenon will be minimised, the static/dynamic friction conversion will not occur and compaction will be diminished. In general the upper limit to the impactor mass will be fixed by machine and operator constraints to the order of 50 kg.

Assuming the energy saving found with cylindrical samples is evident for standard-size blocks, the total energy required for equivalence to 10 MPa quasi-static compaction would be reduced to as little as 70 J/kg. This could be easily applied by a 50 kg mass in only four 150 J blows (17.6 J/kg/blow), the corresponding drop height being 30cm. If no energy saving was evident then 12-17 blows would be required which is still feasible for commercial production.

Overall conclusions concerning dynamic compaction

The research reported in this thesis has shown that dynamic impact compaction has the ability to produce high density soil-cement cylinders and that for a given density a cylinder (100mm diameter) produced by impact is stronger than one produced quasi-statically. Moreover it has shown that the potential energy saving resulting from impact compaction may be as high as 75%. Energy savings of this

potential magnitude warrant the investigation of this method of compaction for standard-size block forming. It was found that quasi-static compaction of standard-size blocks required more energy per kilogram than quasi-static compaction of one of these cylinders but only 8% more. Hence it appears likely that dynamic compaction of a standard-size block will also require more energy but perhaps only 8-10% more.

Even if the energy savings indicated by the research conducted on cylinders significantly diminishes, the case for further investigation of dynamic compaction remains. Impact compaction to high density would require much less costly machines than high pressure quasi-static compaction. Hence it could allow the hidden benefits of high pressure compaction while allowing the blocks produced to be cost competitive with blocks produced through the currently less expensive, low pressure quasi-static compaction route.

9.4 AREAS FOR FURTHER WORK

Areas for further work concerning part A

The development of the Brepack and similar high pressure compaction machines was intended to increase block durability and hence obviate any external render, other than for aesthetic reasons. A field study should be conducted to establish the combined cost of high-strength unrendered building compared to low-strength rendered walling.

Areas for further work concerning part B

Chapter 5 established that the surface strength of blocks was more susceptible to poor curing than the main body strength. It is the author's opinion that good durability is more important than high strength and that the latter does not necessarily indicate the former. Further work is required to devise direct, simple means of

determining surface strength. Any such test should be simple and quick to use. The standard spray-erosion durability test is not appropriate for most block producers as it is time consuming and requires very accurate mass measurement. If a test based on a standardised scratch is developed, testing would be greatly simplified and brought within the reach of even the smallest field producer. In conjunction with this it would be advisable to develop standard curing regimes and to undertake training to increase the significance of curing in the field producers' minds.

The pressure-cement-strength relation reported in chapter 5 is only strictly valid for the particular soil and mould size used during the testing procedure. It would be useful to test this relationship on other soil types with different particle gradings and clay types, formed in standard-size moulds.

One potential advantage of high density moulding, which has not been examined in this thesis and which deserves attention, is the possibility of in-wall curing. With high density moulding the dimensional stability of the blocks is improved. If it may be improved sufficiently then blocks may be laid directly onto a wall, eliminating the need for a costly separate curing area and minimising the level of stock held by a manufacturer. It should be noted that the block need not be completely rigid if a weak mortar is used. Such a curing practice would combine the speed of rammed-earth construction with the quality control of conventional block construction.

Areas for further work concerning part C

The dynamic investigation reported in this thesis dealt with cylindrical samples. Although it was established that these samples were similar to standard-size blocks for quasi-static compression, no dynamic standard-size testing was carried out. It is now necessary to conduct standard-size trials to establish whether the energy savings and improvement in density uniformity recur with larger blocks.

It would also be useful to conduct a further investigation of the compression wave phenomenon to establish its exact defining characteristics. With this information optimisation could be simplified, although it is not necessary for production as a trial and error determination would suffice.

If the findings of this thesis are validated for standard-size blocks suitable machines should be designed to utilise this method of compaction. These should aim to protect the users from the inherent danger associated with a falling weight system but at the same time be sufficiently simple to allow repair by local artisans.

Finally, if the unit production time is found to be long compared to other forms of compaction, the use of blows of increasing magnitude should be investigated. Increasing the blow magnitude during compaction will reduce the number of blows required for a given energy, hence reducing the unit time and also producing the added benefit that the total amount of energy may be reduced too.

BIBLIOGRAPHY

1. Afanasjew, A.A.: Technologie der Impulsverdichtung von Betongemengen. (Moscow, Bauverlag, 1886).
2. Agarwal, A.: Mud, Mud. The Potential of Earth-based Materials for Third World Housing. (London, International Institute for Environment and Development, 1981).
3. Blackedge, .F.: Concrete Practise. (Slough, British Cement Association, 1990).
4. British Standards Institution: Testing Concrete. Method for making test cylinders from fresh concrete. doc. BS1881 part 110 (London, BSI, 1983).
5. British Standards Institution: Methods of Testing Soils for Civil Engineering Purposes. doc. BS1377 (London, BSI, 1991).
6. British Standard Institution: Methods of Test for Stabilised Soil. doc. BS1924 (London, BSI, 1975).
7. Building Research Establishment.: Building in Hot Climates, A Selection of Overseas Building Notes. (London, H.M.S.O., 1980).
8. Carter, M. & Bentley, S.P.: Correlations of Soil Properties. (London, Pentech Press, 1991).
9. Craig, R.F.: Soil Mechanics. fourth ed. (Wokingham, Van Nostrand Rheinhold (UK) Co Ltd, 1987).
10. CRATerre.: Earth Building Materials and Techniques, Select Bibliography. (Eschborn, Federal Republic of Germany, German Appropriate Technology Exchange, 1991).
11. Das, B.M.: Fundamentals of Soil Dynamics. (New York, Elsevier Science Publishing Co, 1983).
12. Doat, P. et al.: Construire en Terre. (Paris, CRATerre, 1979).
13. Fitzmaurice, R.: Manual on Stabilised Soil Construction for Housing. (New York, United Nations, 1958).

14. Grimshaw, R.W.: Chemistry and Physics of Clays and Allied Ceramic Materials. (London, Ernest Benn Ltd, 1971).
15. Groth, A.: The Use of Impact Blows to Compact Soil-Cement Blocks. (Third-year undergraduate engineering project conducted at the University of Warwick, 1984).
16. Handbook For Building Homes of Earth. Department of Housing and Urban Development, Office of International Affairs, Washington, D.C. 20410 (undated).
17. Harris, C.M. & Crede, C.E.:Shock and Vibration Handbook. (London, McGraw-Hill, 1961).
18. Harrison, R.: The Devon Earth Building Initiative. (in English Heritage Conservation Bulletin, No.16, Feb 1992).
19. Hawkins, A.M.: Soil Stabilised with Cement. (Third-year undergraduate engineering project conducted at the University of Warwick, 1988).
20. Head, K.H.: Manual of Soil Laboratory Testing. (London, Pentech Press, 1980).
21. Holthaus, E.W.: Vibratory Techniques in the Production of Precast Concrete Parts and Blocks. (in Concrete Works International, Sept 1992).
22. Holthaus, E.W.: Progress in the Compaction of Industrially Produced Concrete Products by the Use of the Latest Technologies. (in Betonwerk + Fertigteil - Technik, issue 9, 1988).
23. Holthaus, E.W.: Progress in the Compaction of Industrially Produced Concrete Products by the Use of the Latest Technologies. (in Betonwerk + Fertigteil - Technik, issue 10, 1988).
24. Holthaus, E.W.: Optimizing of Concrete Compacting Facilities. (in Betonwerk + Fertigteil - Technik, issue 3, 1992).
25. Hohaus, W.: Optimization of Vibratory Compaction Parameters on a Block Making Machine. (in Betonwerk + Fertigteil - Technik, issue 2, 1992).

26. Hohaus, W.: Effective Compaction - a Prerequisite for Further Automation, Higher Production Output and Improved Quality in Concrete Block Production. (in Betonwerk + Fertigteil - Technik, issue 4, 1992).
27. Ingles, O.G. & Metcalf, J.B.: Soil Stabilization Principles and Practice. (London, Butterworths, 1972).
28. The Institution of Civil Engineers.: Ground Treatment by Deep Compaction. (London, ICE, 1976).
29. International Labour Office.: Small-scale Manufacture of Stabilised Soil Blocks. (Geneva, Switzerland, Technology Series, Technical Memorandum No.12, ILO Publications 1987).
30. Intermediate Technology Development Group (Zimbabwe).: How to Make Stabilised Soil Blocks - Technical Advice Notes Number 2. (Harare, ITDG, undated).
31. Kaysser, D.: Vibration Compaction of Concrete - Fundamental Facts and Interrelations. (in Betonwerk + Fertigteil - Technik, issue 2, 1992).
32. Kuch, H.: Model Formation in Vibratory Compaction of Concrete. (in Betonwerk + Fertigteil - Technik, issue 2, 1992).
33. Kuch, H.: Technical Process Problems Related to the Moulding and Compaction of Small-Sized Concrete Products. (in Betonwerk + Fertigteil - Technik, issue 4, 1992).
34. Lawson, W. Personal communication. (1992).
35. Lawson, W.: Materials for Low-Cost Building in North East Nigeria - Working Paper No.35. (Coventry, Development Technology Unit, University of Warwick, 1991).
36. Lea, F.M.:The Chemistry of Cement and Concrete. (London, Edward Arnold (publishers) Ltd, 1976).
37. Lunt, M.G.: Stabilised Soil Blocks for Building in Building Research Establishment.: Building in hot climates, A Selection of Overseas Building Notes. (London, H.M.S.O., 1980).

38. Mason, K.: Sedimentation Jar and Linear Shrinkage Mould Tests - Suffix to Interim Report. (Report outlining results of Dr Peter Walker at the University of Zimbabwe, ITDG Zimbabwe, 1992).
39. Mukerji, K.:Soil Block Presses. (Eschborn, Federal Republic of Germany, German Appropriate Technology Exchange, 1988).
40. Mukerji, K & Worner, H.: Soil Preparation Equipment. (Eschborn, Federal Republic of Germany, German Appropriate Technology Exchange, 1991).
41. Norton, J.: Building With Earth: A Handbook. (London, Intermediate Technology Publications Ltd, 1986).
42. Ola, S.A. & Mbata, A.: Durability of Soil-cement for Building Purposes - Rain Erosion Resistance Test. (Butterworth-Heinemann Ltd, Construction & Building Materials Vol. 4 No.4, Dec 1990).
43. O'Reilly, M.P. & Brown, S.F.: Cyclic Loading of Soils: from Theory to Design. London, Blackie, 1991).
44. Parsons, A.W.: Compaction of Soils and Granular Materials: A Review of the Research Performed at the Transport Research Laboratory. (London, HMSO, 1992).
45. Perera, A.: Landcrete Blocks (Cement Stabilized Laterite Soil Blocks). (Department of Civil Engineering, University of Moratuwa, Sri Lanka, 1993).
46. Perera, A.: Low Cost House Using Cement Stabilised Blocks and Timber Poles. (Department of Civil Engineering, University of Moratuwa, Sri Lanka, 1993).
47. Spence, R.J.S. & Cook,D.J.: Building Materials in Developing Countries. (Chichester, Wiley, 1983).
48. Spence, R.J.S.: Predicting the Performance of Soil-cement as a Building Material in Tropical Countries. (Building Science, 10, 1975)
49. Stulz, R.: Appropriate Building Materials. (London, U.K / SKAT. St.Gallen, Switzerland, Intermediate Technology Publications Ltd, 1983).

50. Sutcliff, J.: Quality Assurance of Stabilised Soil-Cement Blocks. (Third-year undergraduate engineering project conducted at the University of Warwick, 1994).
51. United Nations.: Soil-Cement its Use in Building. (United Nations Publication, Sales No.: 64.IV.6, 1964).
52. Volunteers in Technical Assistance: Making Building Blocks with the Cinva-Ram Block Press. (Mt. Rainier, Maryland, VITA, 1977).
53. Warwick Graduate School.: Guide to Examinations for Higher Degrees by Research. (The University of Warwick, Sept 1993).
54. Webb, D.J.T.: Stabilised Soil Building Blocks. (University of Newcastle-upon-Tyne, Ph.D. Thesis, 1988).
55. Webb, D.J.T.: The Work of the Building Research Establishment, on Lime Stabilised Soil Blocks for Third World Housing. (Paper presented at the First International Seminar on Lime and Other Alternative Cements, 9-11 December 1991, Stoneleigh, UK, held by the Intermediate Technology Development Group, Rugby, UK, 1991).
56. Williams, F.H.P. & Maclean, D.J.: The Compaction of Soil. A Study of the Performance of Plant. Transport & Road Research Technical Paper No. 17. (London, H.M.S.O., 1950).
57. Worrall, W.E.: Clays: Their Nature, Origin and General Properties. (London, Maclaren, 1968).

APPENDIX A:

DESCRIPTION OF SOIL-A

Soil-A is an artificial soil produced at the University of Warwick by blending building sand with grade E kaoline powder. This soil was used for all experimentation to aid repeatability and allow a consistent soil composition throughout the course of the current research work. The soil was blended such that it fell within the ideal specification for soil-cement given by United Nations (1964). This states that the optimum soil composition is; 75% sand, 25% silt and clay, of which more than 10% is clay.

Building Sand:

Grading:	Sand	84.2%
	Silt	8.8%
	Clay	7.0%

Building sand grading curve:

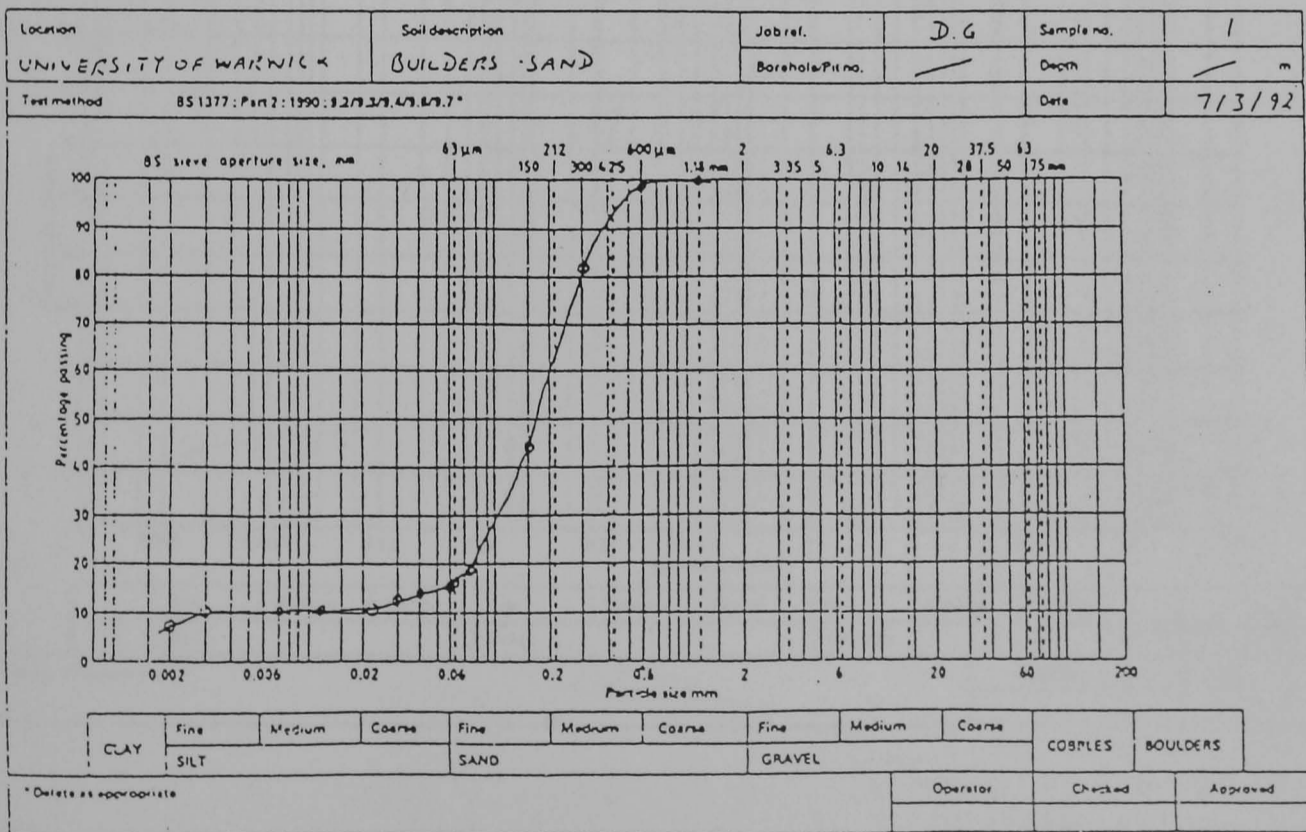

Kaoline Grade E powder:

Specific gravity	2.6
Specific Surface Area	8.0 M ² /g
Water soluble salts	0.15 %
SiO ₂	50 %
Al ₂ O ₃	35 %
Ph	5 ± 0.5

Soil-A mix proportions:	Building Sand	9 parts	(7.2 kg)
	Kaoline	1 parts	(0.8 kg)

Soil-A grading	76.5% Sand
	8.0% Silt
	15.5% Clay

Soil-A grading curve:

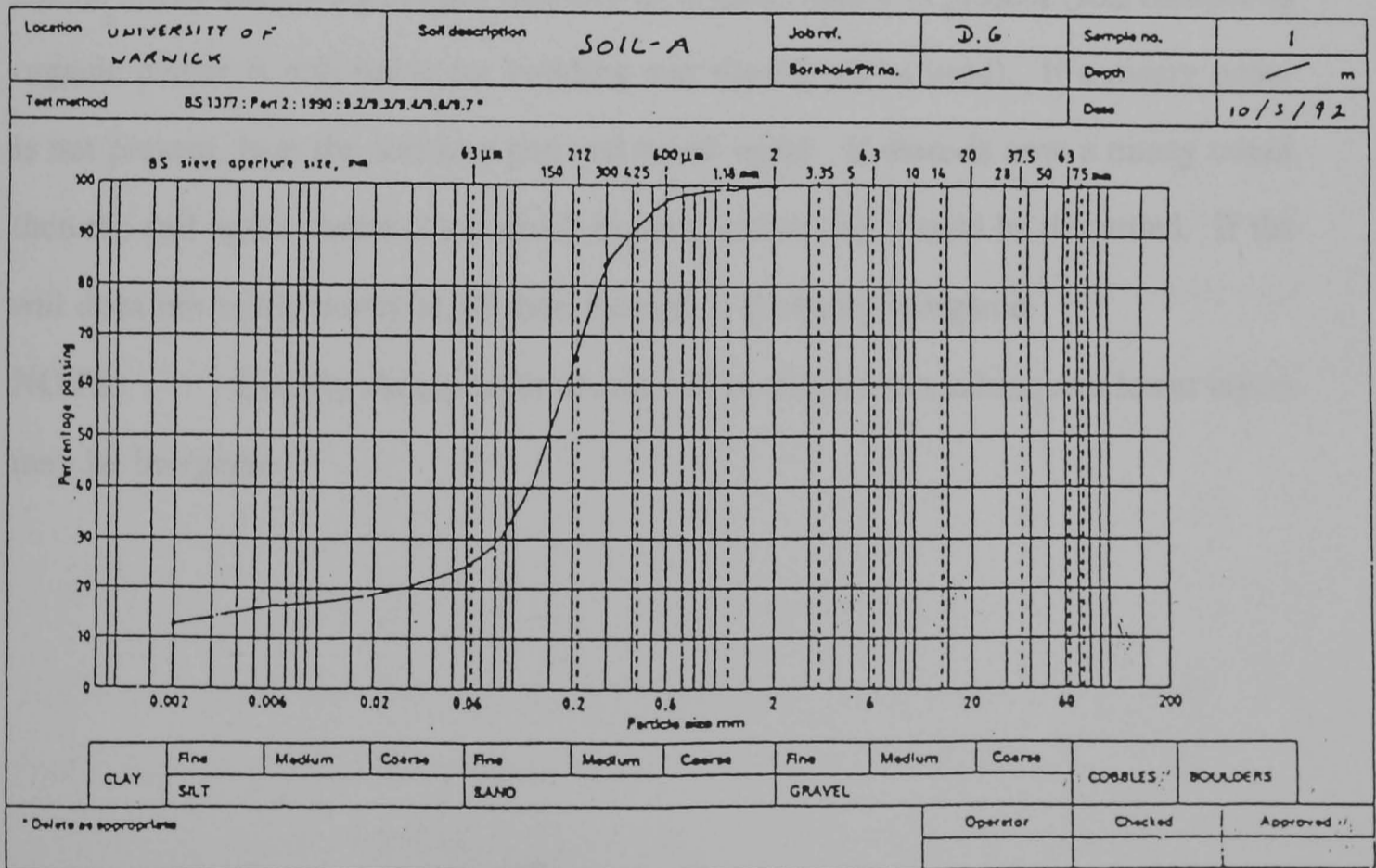

APPENDIX B:

RECOMMENDED SOIL-TESTING PROCEDURES FOR FIELD USE

Smell test

USE : For determining the presence of organic material.
ACCURACY : Medium to high.
TIME : Fast.
LIMITATIONS : This test does not determine the quantity of organic matter present.

EQUIPMENT: Minimal; small cooking stove or fire and a suitable pan.

METHOD: Take a representative sample of moist soil and smell it. If the soil smells musty then a significant quantity of organic matter is present (soil containing organic matter is unsuitable for building and should not be used). If a musty odour is not present, heat the soil in a pan and smell again. If there is now a musty odour then the soil again contains too much organic matter and should be discarded. If the soil does not smell musty at all then the soil is probably inorganic.

NOTE: Usually the top layer of soil will be organic but subsequent lower layers may be inorganic.

Visual-Touch test

USE:	For initial on-site examination of soil to determine the presence of gravel, sand, silt and clay.
ACCURACY:	Dependant on skill of tester.
TIME:	Fast.
LIMITATIONS:	Very difficult to tell silt from clay by a visual examination.

EQUIPMENT: None.

METHOD: *Visual.* Take a representative dry sample of soil. Breakdown any lumps or clods by rubbing between the fingers and examine to gain an idea of the proportion of different size particles. Particles larger than 2 mm are defined as gravel (BS1377) while those smaller than this but still visible to the naked eye form a continuum of coarse through medium to fine sand. The smallest grains visible to the naked eye are fine sand, approximately 0.06 mm. The conventional size boundaries are listed below. The dust which cannot be distinguished as single grains is a combination of silt and clay, normally called the fines.

Touch. The feel of the soil can also be an indicator of its basic components if rubbed both wet and dry. Sands are coarse particles which have a rough feel when rubbed between the fingers. They lack cohesion when wet, they do not stick together well. Dry silt has a similar but less pronounced feel to dry sand and shows limited signs of cohesion when wet. Dry clay usually forms hard but smooth clods. If these are broken down when dry the resulting powder has a smooth slippery feel. When wet, clay has a greasy or sticky feel and is very cohesive.

NOTE: This test is useful if it is used to gain a first broad idea of the soil constituents however unless the soil is a pure sand, silt or clay or the operator has considerable experience it is very difficult to assess the percentage composition. A no fines soil should be reported as *unsuitable, no fines*. Similarly a soil with little or

no sand/gravel should be reported as *unsuitable, very high fines*. Further testing should be carried out if a mixture of sizes is observed.

British Standard and MIT definition of soil particle sizes:

Coarse gravel	60 - 20 mm
Medium gravel	20 - 6 mm
Fine gravel	6 - 2 mm
Coarse sand	2 - 0.6 mm
Medium sand	0.6 - 0.2 mm
Fine sand	0.2 - 0.06 mm
Silt	0.06 - 0.002 mm
Clay	> 0.002 mm

Thread test

USE:	To test for the presence of a large quantity of plastic clay or pronounced lack of fines.
ACCURACY:	Low.
TIME:	Fast.
LIMITATIONS:	Only gives a vague estimate as different clay types have different plasticity. Requires prior operator experience for successful interpretation.

EQUIPMENT: A smooth surface, a sheet of glass or similar.

METHOD: A small representative sample of moist, easily mouldable, soil should be formed into a cylinder about the same size as a thumb. This cylinder should then be lightly rolled with uniform pressure on a smooth flat surface by the outstretched fingers of one hand, forming a thread of soil (if it is not possible to form a thread report as *unsuitable, very low fines*). The thread will reduce in size until it breaks, either by snapping into shorter pieces or shearing along the length of the sample. The size at which the thread breaks gives an indication of the clay content. If the sample

will easily form a 3 mm or lower diameter thread then there is probably a high plastic clay content. If the thread breaks at a larger diameter than 3 mm then there is either a moderate sand and silt fraction present or the clay is only slightly plastic. If the sample appears to have a high plastic clay content then it should be reported as unsuitable, very high fines.

NOTE: This is a simplified version of the Atterburg plastic limit. For the full test see the laboratory tests section.

Ribbon test

USE:	To test for the presence of a large quantity of plastic clay or pronounced lack of fines.
ACCURACY:	Low.
TIME:	Fast.
LIMITATIONS:	Only gives a vague estimate as different clay types have different plasticity. Requires prior operator experience for successful interpretation.

EQUIPMENT: none

METHOD: Take a representative sample of soil sufficient to form a roll about the diameter of the thumb but three times longer (a comfortable size to fit in the palm of the hand with the fingers rolled in to make a hollow fist). Wet this soil so that the sample is damp but not overly sticky. Hold the sample in the palm of the hand with the fingers rolled over and push the sample out from between the thumb and first finger, flattening it to form a ribbon 4 - 6 mm in thickness. Let the ribbon hang down from the hand, without supporting it, and see how long it gets before it breaks. Compare the length at which it breaks with the lengths given below.

- 0 cm, no ribbon at all. This indicates that the soil contains very little or no clay and should be reported as *unsuitable, no clay*.

- 4 - 10 cm, short ribbon. This indicates a soil containing a low to moderate quantity of clay and should be reported as provisionally suitable. The longer the ribbon then the larger the quantity of stabiliser which will be required for adequate stabilisation.
- 25 cm and longer, long ribbon. This indicates a soil containing a high quantity of clay and should be reported as *unsuitable very high fines*. Such a soil would require an uneconomically high quantity of stabiliser for adequate durability.

NOTE: The lengths given above are not a set of rigid rules but should be treated as a set of guidelines. With experience of testing the local soils these lengths should be revised to improve the selection accuracy.

Shine test

USE:	For determining the major soil components and identifying a silt or clay dominated soil.
ACCURACY:	Low.
TIME:	Very fast.
LIMITATIONS:	This test determines which is the major soil component (sand, silt or clay). It does not determine the quantities present.

EQUIPMENT: Sharp knife (optional).

METHOD: Take a representative sample of soil. Moisten it and form into a ball. Cut the ball with sharp knife or polish a section of it with a fingernail. If the resulting surface is shiny the soil is predominantly clay. If the surface is dull and feels abrasive or harsh then the soil is predominantly sand or silt. Sand and silt may be

distinguished by closely examining the surface. If the surface appears grainy then the soil is a sand. If grains cannot be seen the soil is silty.

Bite test

USE: For differentiating between silt and clay on-site.
ACCURACY: Dependent on skill of tester.
TIME: Very fast.
LIMITATIONS: Only useful for distinguishing on a presence/absence basis.

EQUIPMENT: None.

METHOD: Take a pinch of soil and lightly grind it between the front teeth. Any sand present will feel harsh or gritty and unpleasant. Silt will also feel gritty but much less unpleasant. Clay will feel smooth or flour-like.

Sedimentation test (glass jar)

USE: A simple test to give a rough numerical value to the percentage fraction of soil components.
ACCURACY: Medium to low.
TIME: Slow (up to 24 hours).
LIMITATIONS: The results from this test give an idea of the soil's component parts to a low accuracy. The low accuracy is due to the difficulty in discriminating the layer boundaries and the slow settling movement of these boundaries over time.

EQUIPMENT:

- 1 Wide transparent glass jar (> 65 mm diameter), straight sided and flat bottomed with a capacity greater than half a litre.
- 1 Bung for the glass jar (optional).
- 1 Stopwatch or clock.
- 1 Ruler long enough to measure the height of settled material.
A supply of clean drinking water.

METHOD: A representative sample of soil is loosely placed in the glass jar up to one quarter of its depth for sandy soils or one quarter to one sixth of its depth for silty or clayey soils. Clear drinking water is placed into the jar to fill it almost to the top. The bung is then placed in the mouth of the jar and the jar left undisturbed until the soil is completely soaked with water. The jar is then shaken vigorously for one or two minutes and placed on a flat level surface to stand undisturbed for one hour. The jar is then reshaken for a further minute, replaced on the flat surface and the stopwatch started. The jar must now be left **UNDISTURBED**. After forty five minutes it should be possible to see a layer of sand settled at the bottom of the jar and a further layer of silt settled above. The cloudy suspension above the silt layer is the soil's clay content (if a pronounced clear layer is seen the soil has flocculated and should be treated with one of the chemical agents listed below). The clay settles out much more slowly than the sand or silt, settling at approximately 12 mm per hour. After a further 12 - 24 hours the clay should also have settled. The different components can now be measured by measuring the height of the three layers. If the silt/clay boundary cannot be seen and the suspension has not flocculated then the experiment may be repeated using the timing system put forward by Norton (1986), the height of settled material is recorded after 1 minute, 30 minutes and 12 to 24 hours (depending on fineness of clay). The total depth of the sediment (not including the water remaining above) is taken as 100% of the soil. The height of each layer is then recorded as a percentage of the total depth. The three values then taken to be the sand, silt and clay content of the soil.

NOTE: This test has been in wide use for a long time but with some significantly different methods of application. The test is based upon Stoke's law of sedimentation which predicts the rate of settling for a spherical particle in free fall. This is only strictly valid for low concentrations of spherical particles. The jar test then has two

sources of primary error in that the particle concentration is not low and the particles are not spherical, particularly so when considering the clay fraction, most clay particles being a plate-like shape. Results from this test should always be treated with caution.

This test frequently contains instructions to add a pinch of salt as a deflocculent. This is incorrect: salt should not be added except under special circumstances (for details see above, section 4.3.3 Sedimentation tests). Suitable deflocculents / dispersants are listed below.

Deflocculents after Head (Head 1980):

sodium bicarbonate	starch
sodium carbonate	sodium silicate
sodium hexametaphosphate	tannic acid
sodium tetraphosphate	sodium hydroxide
sodium oxalate	trisodium phosphate 4l for laterites
sodium tripolyphosphate	tetrasodium phosphate l for laterites
sodium polyphosphate	

also: gum arabic (United Nations 1964)

Dry strength test

USE:	Additional test to estimate whether silt or clay predominate in the fines of a combination soil.
ACCURACY:	Low, dependant on operator judgement.
TIME:	Slow if sedimentation is used to prepare the sample, faster if dry sieved.
LIMITATIONS:	Only low accuracy without prior operator experience.

EQUIPMENT:

EITHER	1	Wide transparent glass jar (> 65 mm diameter), straight-sided and capacity greater than half a litre.
	1	Syphon tube of suitable length approx 5 mm diameter.
	1	Separation disk with stem. A flat disk just smaller than the diameter of the glass jar attached to a suitable stem so that the disk may be lowered into the jar.
	1	Stopwatch to time thirty seconds.
	1	Wide dish to collect the syphoned liquid. Approx 150 mm diameter.
		A source of clean water (as clear as possible).
OR	1	0.06 mm. sieve and collector.

SYPHONING METHOD: Place loose soil into the jar up to one quarter of its depth. Add water to nearly fill the jar, cover the mouth and shake vigorously. Leave to stand for one hour to allow the soil to soak.

Shake the jar vigorously for approx two minutes and stand on a solid flat surface. Time for thirty seconds from placing the jar on the flat surface.

Lower the separation disk quite quickly into the jar so that it covers (without disturbing) the sand settled after thirty seconds. Syphon off the liquid containing the remaining suspended matter into the wide dish. The easiest way of doing this is to tie one end of the syphon tube to the base of the separation disk's stem. This anchors the tube, preventing it from floating.

The particles will slowly settle out of the water in the wide dish leaving clear water. This water should then be decanted off, either by carefully pouring, without disturbing the settled material, or preferably by syphoning. Not all of the water should be removed like this as inevitably some material would be lost. The remaining water should be evaporated off.

DRY SIEVING METHOD: If a 0.06 mm sieve is available the silt and clay portion of the soil may be removed from the soil mass by dry sieving. A representative sample of soil should be dried and completely sieved through the 0.06 mm sieve. The material passing through the sieve should be collected and used for the test below. See section 4.3.2 for a discussion of sieving techniques.

The resulting material should then be well mixed with a little water to evenly distribute the particles and a representative sample should be formed into a 2 cm diameter ball. This ball should be soft but not sticky, (a dough-like consistency).

The ball should then be dried out either by gently heating or by leaving in the sun.

When dry the ball should be crushed between the first finger and thumb. The resistance of the ball to crushing gives an estimate of the type of fine predominating. If the ball falls apart when picked up then the soil either has a very low fines content or no clay and should be reported as *unsuitable, very low fines*. If the ball crushes easily the fines are very fine sand, inorganic silt or a combination of very fine sand, silt and a small quantity of clay. This reaction should be reported as *suitable, low fines*. If it crushes with moderate difficulty the fines are an organic clay, a silty clay or a sandy clay and should be reported as probably *suitable, high fines*. If the ball cannot be crushed or only with considerable difficulty the fines are an inorganic highly plastic clay and should be reported as probably *unsuitable, very high fines*.

Surface water test

USE:	Additional test to estimate whether silt or clay predominate in the fines of a combination soil.
ACCURACY:	Low to medium.
TIME:	Slow if sedimentation is used to prepare the sample, faster if dry sieved.
LIMITATIONS:	Requires careful observation.

EQUIPMENT: As for the dry strength test above.

METHOD: Follow the instructions for the dry strength test (above) to produce a soft 2 cm ball. The ball is then held in the palm of one hand and repeatedly jarred horizontally by striking against the other hand.

As the ball is jarred either a film of water may appear on the surface, characterised by a shiny appearance, or no change will occur. After noting the preceding reaction, squeeze the ball with the fingers of the other hand. Either the water will disappear from the surface, the mass hardening and eventually crumbling or the appearance will not change, the ball being deformed into a soft plastic mass.

Repeat the above shaking and squeezing steps several times to be sure of the reaction.

If water appears and disappears quickly, the ball hardening when squeezed then the fines are a very fine sand or an inorganic silt. Reported as *unsuitable, very low clay*.

If water appears and disappears slowly then the fines are a slightly plastic silt or a silt containing a small amount of clay. Reported as *suitable, low clay*.

If no water appears on shaking and the ball is deformed into a soft plastic mass on squeezing then the fines are predominantly clay. Reported as *provisionally unsuitable, very high clay*.

NOTE. If the sample is a silt containing some clay, water will appear on shaking but may only partially disappear on squeezing, the ball feeling slightly plastic. Reported as *suitable, high clay*.

APPENDIX C:

RECOMMENDED SOIL-TESTING PROCEDURES FOR LABORATORY USE

Dry Sieve Test

USE:	To separate grades of sand on a size basis and give a value for the total fines content (silt and clay) for low-cohesion soils.
ACCURACY:	High (providing the soil is sufficiently broken down).
TIME:	Medium/slow.
LIMITATIONS:	The results from this test usually give an accurate breakdown of the sand fractions but silt and clay are too fine to be easily separated by sieving. If the soil is not easily broken down into individual particles the wet sieve test should be used.

EQUIPMENT:

1 SET	Nesting sieves	6 mm	Coarse and medium gravel
		2 mm	Fine gravel
		0.6 mm	Coarse sand
		0.2 mm	Medium sand
		0.063 mm	Fine sand
1	Suitable sized collector to catch the combined silt and clay fraction passing the 0.063 mm sieve.		
1	Mass measurement balance.		

METHOD: The dry sieve test is very simple to conduct if suitable sized sieves are available or can be made. A large (2 Kg) representative sample of soil is taken and thoroughly dried either in a pan over a stove or by spreading the sample out and leaving it in strong direct sun. From the dry sample two accurately weighed sub samples of about 1 Kg are taken, (500 g is adequate if the soil is fine). The following procedure is then carried out on each and the results averaged. The sieves are stacked

in order of decreasing size, the 6 mm sieve at the top of the stack and the collector at the bottom. The weighed soil sample is then broken down into individual particles either by hand or by light grinding in a pestle and mortar. Re-weigh the sample if any material is lost in grinding. Place the weighed sample in to the top sieve. The set of sieves is then shaken until no more material passes from one sieve to the next, this may take some time to complete, (15 minutes or more), as particles slightly larger than the sieve aperture size tend to jam in the holes and blind the sieve. If this occurs gentle brushing of the sieve with a soft brush will unblock these holes, but care must be taken not to force material through the holes as this would give a false value.

Once material transfer has stopped the soil particles lying on top of each sieve are carefully removed and weighed, remembering to brush the material from any blinded holes. The mass of the material on each sieve is converted to a percentage of the total mass hence giving a simple particle size analysis, but without distinguishing silt and clay. Soil loss during the experiment can be checked by comparing the initial mass with the sum of the mass of the separated fractions.

NOTE: This test may be carried out with the sediment from the syphon test (described below), the material in the collector should then be silt as the clay will have been removed but the smaller sample size requires more accurate mass measurement. If accurate mass measurement is available this will give a more reliable result than dry sieving as the clay fraction, which tends to adhere to larger particles when dry, will have been washed off.

Sedimentation test (syphon)

USE:	A more accurate version of the glass jar test enabling direct measurement of the clay fraction weight.
ACCURACY:	Medium to high.
TIME:	Slow.
LIMITATIONS:	The accuracy of the results depend on successfully separating the clay fraction (see comments above on flocculation).

EQUIPMENT:

- 1 Flat-bottomed glass jar, approximately 65 mm internal diameter and 1 litre capacity (a rubber bung to close the end of the cylinder is useful but not essential).
- 1 Flat circular disk on a stem such that it may be lowered into the cylinder. The disk should be slightly smaller than the internal diameter of the cylinder with the stem 10 cm longer than the height of the cylinder.
- 1 Flexible rubber syphon tube to remove suspended material from the cylinder.
- 1 Stopwatch or clock.
- 1 Weighing balance accurate to at least 0.1 g preferably 0.01g.
- 1 Heat proof container to receive the syphoned suspension.
A clean supply of water.

METHOD: Weigh out a representative 100 g sample of dry soil and place it in the cylinder. Add clean water to 200 mm, measuring the height from the internal cylinder base. Close the cylinder with the palm of one hand or a suitable sized rubber bung and shake it vigorously end over end to produce a uniform suspension of soil. This may take some time depending on the type of soil. If the soil does not appear to form a uniform suspension then leave it to soak for thirty minutes and reshake. Once a uniform suspension has been formed place the cylinder on a flat steady level surface and begin to time 20 minutes.

At the end of 20 minutes slowly lower the disk to cover the settled material, taking care not to disturb it. If the soil contains a high proportion of fines, it may not be possible to see the upper edge of the settled layer. If this is the case then repeat the experiment using a smaller soil sample. (The top layer of material is silt, if the

disk is allowed to rest on the surface then some silt will be forced up around the edge of the disk. Any silt forced back into suspension will give a misleadingly high value for the clay fraction.) The remaining suspended material may now be syphoned off with the rubber syphon tube. The syphoning operation is more simple to perform if the tube is tied to the stem just above the upper face of the disk. This stops the tube from floating or curling.

The material syphoned off is then dried, weighed and recorded as the clay fraction. The purity of the dried clay fraction may be tested with the bite test above if silt contamination is suspected. The settled material should then be combined sand and silt, these should now be separated by sieving. The sieving may be done wet or dry. In this case, the soil having had the cohesive clay component removed, dry sieving is the more appropriate. The settled material should be dried and placed into the top of the set of sieves as described above for the dry sieve test. In this case the material passing the 0.063 mm sieve is the silt fraction.

NOTE: This test is also based on Stoke's law of sedimentation and hence open to the problems mentioned for the glass jar sedimentation test. In particular salt is not a suitable deflocculent, one of the reagents mentioned above (Glass-jar sedimentation test) should be used if required. Flocculation should always be avoided if possible as it results in significant "wipe down" of the clay fraction (see below) and frequently results in a semi-settled layer of combined silt and clay above the settled material, causing difficulty in determining the level for the disk.

The syphon test uses a less concentrated sample of soil than the glass jar test and hence is more accurate but it is still prone to "wipe down" whereby the larger soil particles carry the smaller particles down with them. These effects can be reduced by carrying out a second syphon test on the settled remains of the first test, subsequently combining the two clay fraction values to give a more accurate reading. However this does increase the time required for the test.

Wet sieve test

- USE:** To separate sand from the fines, particularly for lateritic soils which are difficult to breakdown when dry and may contain clay trapped in particle fissures.
- ACCURACY:** Medium to high.
- TIME:** Slow, dependant on the drying time after wet washing.
- LIMITATIONS:** Flushing the soil particles down through the set of sieves requires quite large quantities of water which must be subsequently dried off before weighing the sample. Care must be taken when handling this water to prevent loss.

EQUIPMENT:

- | | | | |
|-------|---|----------|--------------------------|
| 1 set | Nesting sieves | 6 mm | Coarse and medium gravel |
| | | 2 mm | Fine gravel |
| | | 0.6 mm | Coarse sand |
| | | 0.2 mm | Medium sand |
| | | 0.063 mm | Fine sand |
| 2+ | Two or more large-sized collectors to catch the wash water carrying the combined silt and clay fraction passing the 0.063 mm sieve. | | |
| 1 | Mass measurement balance. | | |
| | A clean supply of drinking water. | | |

METHOD: A representative dry sample of soil is weighed out accurately, about 1 kg for fine soils and 2 kg for coarse soils. This sample is mixed in a suitable clean bowl with an excess of water and left to soak for 1 hour. If available a dispersant should be added to aid the particle separation. Suitable dispersants are listed above under the glass jar sedimentation test. After one hour the soil is remixed and poured into the nesting sieves making sure to rinse any soil residue into the sieves with more water. The soil is then washed through the sieves with more water until no further particle transfer occurs between sieves. This may be checked by judicious inspection. This will require a large quantity of water and hence the collector should be regularly checked and replaced when nearly full.

When washing has been completed the soil fractions on each sieve should be dried, weighed and recorded as a percentage of the initial mass.

The wash water should be left to stand undisturbed until clear. This clear water can then be removed by syphoning or carefully pouring off without allowing any material to be lost. The residue is then either dried, weighed and recorded as a percentage as above or further separated into silt and clay fractions by the Sedimentation test (syphon).

SIMPLIFIED METHOD: If the wash water is allowed to run to waste then the total fines content may be found by subtracting the combined collected masses from the initial mass. The clay fraction may then be found from a separate sedimentation test and the silt fraction would be assumed to be the difference between the combined sand and clay percentage and 100%.

Atterburg Limit tests

USE: To provide an indication of the properties of the soil fraction finer than 0.425 mm.

ACCURACY: Medium to high.

TIME: Medium/slow.

LIMITATIONS: Considerable difficulty may be experienced finding the plastic limit when the soil contains a low plasticity clay. Tests on the same sample may give different results if performed by different operators.

EQUIPMENT:

- 1 Curved dish approx 93 mm diameter, 27 mm deep at centre.
 - 1 Grooving tool to form a 2 mm wide, minimum 8 mm deep groove with sides 60 degrees off horizontal, or a knife to cut the groove.
 - 2 Water proof, air-tight containers, one large enough to hold approx 250g of soil, the other large enough to hold approx 100 g of soil.
 - 1 0.425 mm. sieve.
 - 1 Flexible blade to mix the soil.
 - 1 Smooth surface. eg. plate glass 200 x 200 mm.
 - 1 3 mm diameter rod (optional).
 - 1 Mass measurement balance.
- A supply of clean drinking water.

METHOD: Dry a representative sample of soil, grind it in a pestle and mortar to break up any agglomerations of particles and sieve it through the 0.425 mm sieve to give a sample of about 200 g. Place this sample into the larger air-tight container and seal it. The following two tests should be performed on this sieved sample.

Liquid Limit. Mix about 70 g of the soil sample with the drinking water to form a thick homogenous soil paste. The mixing operations should continue for about 10 minutes but if the soil contains a moderate to high quantity of clay then the mixing stages should be very thorough taking up to 30 or 40 minutes each. With the flexible blade, smooth this paste into the curved dish, taking care not to trap any air. The soil should be 8 mm deep at the centre of the dish and full height at the edge. Using the grooving tool (or a sharp knife), divide the paste in two across a diameter leaving a clean groove 2 mm wide with sides 60 degrees from the horizontal.

Solidly hold the dish level in one hand with the groove pointing away from the body. Gently tap the dish horizontally against the heel of the other hand by moving it 30-40 mm (keep the empty hand still). After 10 taps the groove should close so that the two portions of soil come into contact along the bottom of the groove over a continuous distance of 13 mm. If the groove closes before 10 taps then the soil is too wet. It should be removed from the dish and more dry soil mixed with it and the test repeated. If the groove does not close after 10 taps then the soil is too dry. It should be removed, mixed with more water and the test repeated.

When the groove just closes over 13 mm the soil is at its liquid limit, put the sample into a pre-weighed container, seal it and reweigh it. Then dry the sample and weigh it again. The plastic limit is now found by calculating the mass of water in the sample as a percentage of the soils dry mass.

Plastic Limit. Take about 10 g of the sieved soil sample and mix it with water to form a thick paste which should be malleable but not sticky. Roll the soil into a ball with the hands until it begins to dry and crack slightly. Divide the ball into four roughly equal parts and follow the following procedure for each part.

Mould the soil into a cylinder about 6 mm diameter. Place it on the flat surface and roll it under the fingertips with an even light pressure to reduce its diameter to 3 mm (check with the 3 mm rod) after between five and ten back-and-forth movements, slightly more for heavy clays. It is important to maintain a uniform rolling pressure throughout (do not reduce the rolling pressure as the thread approaches 3mm). If the sample breaks into pieces by shearing longitudinally or laterally at 3 mm diameter it is at the plastic limit. If it breaks before 3 mm, slightly wet the sample and retest. If it does not break at 3 mm it is too dry. Roll the sample between the palms of the hands and retest. If the soil always breaks before 3 mm then it should be recorded as non plastic¹.

When the soil breaks at 3 mm, quickly gather the pieces together, place them into a pre-weighed air-tight container, seal the container and repeat the test with the next soil sample. When all samples have been tested weigh and record the sealed container's mass then dry the sample and reweigh. Calculate the percentage of water as a fraction of the dry weight. This percentage is the plastic limit.

Plasticity Index. The plasticity index is the numerical difference between the liquid and plastic limit recorded as the nearest whole number.

¹. A non plastic soil may still be suitable for soil cement production provided that some clay is present. The plastic limit test is a standard reference and failure to produce a result does not automatically mean that the soil should be rejected. For soil with a low clay content or containing a clay of low plasticity considerable difficulty may be experienced in attaining a plastic limit despite the soil exhibiting some plasticity.

Shrinkage test

USE:	To provide an indication of the cement content required for a given soil compacted with a low pressure moulding machine such as the Cinva Ram.
ACCURACY:	Medium.
TIME:	Slow (at least seven days drying time).
LIMITATIONS:	Requires a large soil sample and mould. It may take seven days for the shrinkage to be complete. This test has been calibrated for use with particular presses and as such is not directly relevant to machines operating at different compaction pressures.

EQUIPMENT:

- 1 rectangular mould box of internal dimensions 40x40x600 mm.
- 1 6 mm sieve.
- 1 mixing container and mixing implements.
- a supply of clean water (drinking water).
- a ruler or tape measure.
- a lubricant, either silicone grease, mould release oil, used engine oil or grease.

METHOD: The internal length of the mould cavity is accurately measured and recorded. All of the internal mould faces are smeared with the available lubricant to reduce the tendency of the soil to adhere to the mould.

A representative damp soil sample is taken and sieved through the 6mm sieve. This soil is then thoroughly mixed with water until it has a wet pudding or porridge-like consistency (this should occur near the liquid limit, see above). The mould is then filled with this soil mixture, in three roughly equal layers. After the addition of each layer the mould box is tapped to remove any air trapped in the soil. When the final layer has been tapped the excess soil is removed from the top of the mould leaving a smooth, flat soil surface. It is important that the soil does not extend beyond the internal edge of the mould wall as this will increase the soil drag as the sample dries.

The mould containing the soil sample is then placed in a shaded area to dry. Once the soil appears to be shrinking away from the box sides it may be moved into direct sunlight to speed the drying process. The mould should be protected from rain throughout the drying time.

When the drying is complete the length of the dry soil sample should be accurately measured and recorded. If the sample has cracked across its width and separated into several pieces these pieces should be pushed together and the combined length recorded. If the soil has hogged up out of the mould forming a crescent-shaped length, the length of both upper and lower faces should be measured and their average recorded as the dry length. Cracking indicates a soil containing a high sand/silt fraction while hogging indicates a high clay content.

The linear shrinkage on drying may then be found by subtracting the dry soil length from the length of the mould box. This shrinkage length may then be referred to the table given below after VITA for the low-pressure (2MPa) Cinva Ram machine and after Webb for the high-pressure (10MPa) Brepack machine (Ref 5, Webb 1988).

Measured Shrinkage (mm. per 600 mm)	Recommended* Cement percentage (for Cinva Ram)	Recommended* Cement percentage (for Brepack)
under 5	too difficult to handel when block making	
5 - 15	5.56	perhaps insufficient clay (see sect'4.3.5)
15 - 30	6.25	5.0
30 - 45	7.14	6.7
45 - 60	8.33	8.3
over 60	not suitable for use unless more sand is added	

* The Cinva Ram blocks are to meet a wet strength criteria of around 1MPa, while the Brepack blocks meet a criteria of around 2.8 MPa. If the same strength criteria were to be used the high-pressure Brepack blocks would probably require about 40% less cement that the low-pressure Cinva blocks.

APPENDIX D:

EXPERIMENTAL METHOD USED TO PRODUCE STANDARD-SIZE BLOCKS AND SMALL CYLINDERS (50mm diameter) BY QUASI-STATIC COMPACTION

UNSTABILISED BLOCK PRODUCTION (290X140X100mm)

For each block a batch of *Soil-A* was manufactured and mixed for 5 minutes with distilled water to give a moisture content of 4% (for batch proportions see below). This batch was then left overnight to homogenise before remixing to 8% moisture content. All batch proportions were weighed to $\pm 0.05\text{g}$. All mixing was mechanical, using a large Hobart soil mixer.

The material to fill the mould was weighed out as three equal quantities into three plastic bags and sealed. After oiling the mould with a release agent (engine oil), the soil was placed in the mould. The contents of each bag was lightly tamped before adding the next. The mould top was then placed on the soil and its height above the compression machine bed measured and recorded. A dial gauge was then positioned such that the block height during compaction could be measured.

The block was then compressed in 5 tonne force increments up to 40 tonnes. After each force increment the applied force was held constant long enough for the block height and both LVDT readings to stabilise and be recorded (typically 1 minute). The block was then decompressed in a similar manner.

The compressed block was ejected from the mould by pressing the mould walls down over the lower piston. The green block was then transferred to a wooden base plate and its final dimensions recorded.

UNSTABILISED MIX PROPORTIONS

7.200kg builders sand (0.5% moisture content)
0.800kg kaoline grade E powder (0.7% moisture content)
0.277kg distilled water (for 4% homogenisation)
0.318kg distilled water (8% moisture content for compaction)

Mass of 8% moisture content *soil-A* for block compaction 8.532kg

STABILISED BLOCK PRODUCTION (290X140X100mm)

For stabilised block production the above method was used but after homogenisation at 4% moisture content, 0.398kg of cement and 0.350kg of distilled water were added.

On ejection from the mould the green blocks were transferred to a plastic bag containing a damp tissue and sealed. The blocks were then left to cure for six days before immersion in water for the final 24 hours. Curing temperature was 22-24°C. After seven days the blocks were tested for wet compressive strength. Both the upper and lower block faces were capped with fibre board before compressive strength testing in a Denison concrete testing machine.

STABILISED SOIL-CEMENT CYLINDERS (ϕ 50mm, height 100mm)

The method given below is a copy of that used during manufacture. Six days after compaction each sample was soaked for 24 hours. On the seventh day after compaction the samples were capped with fibre board and tested for compressive strength in a Denison concrete testing machine. Although the Denison machine was operating below its range of grade 1 calibration (± 1 %) it had been recently recalibrated by an authorised testing house who indicated that the largest error given by the machine would be ± 3 % of the recorded value.

1. Measure out all ingredients for required batch. The water should be weighed into a pre-wetted container to allow for the quantity which remains in the container.
2. Place the 4% homogenised soil in the mixer. Sprinkle the cement onto the soil and note the time. Mix for 2 to 3 minutes or until the mixture looks uniform in colour, place a large plastic bag around the top of the mixer's bowl to reduce the evaporation of the water. Sprinkle in the weighed water, try not to pour the water onto the sides or the mixing paddle. Mix for a further 3 to 4 minutes or at least until the mixture looks uniform.
3. Weigh out 453.6g of the mixture, leaving the mixing bowl covered with a large plastic bag to reduce the moisture loss.
4. Oil the mould with the release oil and assemble for filling. Place approximately one third of the mixture into the mould using the paper funnel. Take care not to spill any soil. Tamp the soil down with the steel bar. Repeat this for the next two thirds of the mix. Place the mould piston on top and try to centralise the main body between the end pistons.
5. Place the mould, red ring down, in the centre of the compression machine plated and compress to the required force twice (forces listed below).
6. Lift off the compression machine. Remove top and bottom pistons. Place the ejection ram in the base and the collars on top of the mould. Lower the compression machine to eject the sample. If you try and rotate the mould while compressing, it will be apparent when the sample has been ejected far enough for final removal by hand. Note the time that the sample was ejected.
7. Write the identification number on the top face and place it into a plastic bag. Repeat the above for the next two cylinders and then weigh and measure the length of each. Finally place them inside a plastic bag with one moist tissue and seal the bag.

Compaction forces:

1 MPa	= 1.960 kN	use 2.0 kN	(1.018 MPa)
2 MPa	= 3.93 kN	use 4.0 kN	(2.037 MPa)
4 MPa	= 7.85 kN	use 8.0 kN	(4.074 MPa)
6 MPa	= 11.78 kN	use 12.0 kN	(6.112 MPa)
8 MPa	= 15.71 kN	use 16.0 kN	(8.149 MPa)
10 MPa	= 19.63 kN	use 20.0 kN	(10.186 MPa)

ORDER:

Start with 10 MPa compression and 11% cement. Follow with 10 MPa 9% etc. This should minimise confusion with the compression machine!

BATCH PROPORTIONS:

All cylinders are to be compacted at 8 % moisture content and a dry mass of soil + cement of 420g, giving a fill mass per cylinder of 453.6g .

The figures below relate to batch mass measures. Each batch should contain enough material to make 3 cylinders with some material left over, approximately 225g.

It is important to remember to note the time when the cement is added to the 4% moisture content soil.

BATCH TO MIX UP AND STAND OVERNIGHT (measure all mass to ± 0.05 g):

9kg	lab-dry soil
1kg	kaolin from bag
0.347kg	distilled water

3% CEMENT BATCH:

1484.4g	4% homogenised soil
42.7g	cement
60.6g	distilled water

5% CEMENT BATCH:

1456.0g	4% homogenised soil
70g	cement
61.7g	distilled water

7% CEMENT BATCH:

1428.7g	4% homogenised soil
96.3g	cement
62.7g	distilled water

9% CEMENT BATCH:

1402.5g	4% homogenised soil
121.5g	cement
63.8g	distilled water

11% CEMENT BATCH:

1377.3g	4% homogenised soil
145.6g	cement
64.8g	distilled water

APPENDIX E :

EXPERIMENTAL INSTRUMENTATION AND EQUIPMENT USED DURING QUASI-STATIC COMPACTION OF STANDARD- SIZE BLOCKS AND SMALL CYLINDERS (50mm diameter)

THE LVDT TRANSDUCER

The LVDT transducer (see figures E1, E2 and E3) was designed to flush-mount in the mould-walls. The main body of the transducer is machined from EN24T steel to form a circular spring. The thickness and shape of the spring are such that it will remain well inside the elastic region of the steel such that deflection is proportional to the applied load. The spring is deflected by a cylindrical piston mounted in a tubular guide. Both the outer faces of the tubular guide and of the cylindrical piston are flush with the spring body face and mould wall under conditions of no load.

The LVDT plunger is screwed into the rear spring boss. The LVDT body is clamped inside the transducer by the olive ring. Any deflection of the spring is sensed by the LVDT and converted into a voltage signal. The voltage output from the LVDT is fed into a conditioner and finally displayed on a digital voltmeter. The LVDT transducers and conditioners are both made by Schlumberger Industries and were supplied by RS Components Ltd, catalogue No. 646-527 and No. 646-599 respectively. The Schlumberger Part numbers are LVDT SM1 and type OD3 911040 transducer conditioner.

Initially quite large hysteresis was observed on unloading. This was found to be caused by an airlock between the piston and the spring body. The design was subsequently modified by including a 1.5mm diameter vent hole. Two such transducers were manufactured and used during the experimentation.

Figures E4 and E5 show the calibration plots for transducer No.1 and No.2 respectively. Minor machining differences led to each unit having a different spring constant and hence a different gain. The gain of each unit was found to be constant over time and constant within normal laboratory temperatures. The zero offset was found to vary with time, typically 1mV per 30 minutes. The zero load voltage was recorded immediately before each experiment so that the zero offset could be determined, this offset was assumed to remain constant for the duration of each test (20 minutes). The transducers' hysteresis lead to a 0.1MPa over reading after four full cycles.

The pressure transmitted to the mould wall was found by entering the recorded voltage into the transducer equation:

$$y = mx + c$$

where y = transmitted pressure /MPa

m = transducer gain (found from calibration curves) /MPa/mV

x = recorded voltage /mV

c = zero offset correction (found by $c = - mx$ at zero load)

Figure E6 shows the possible locations for the transducers in the mould side wall.

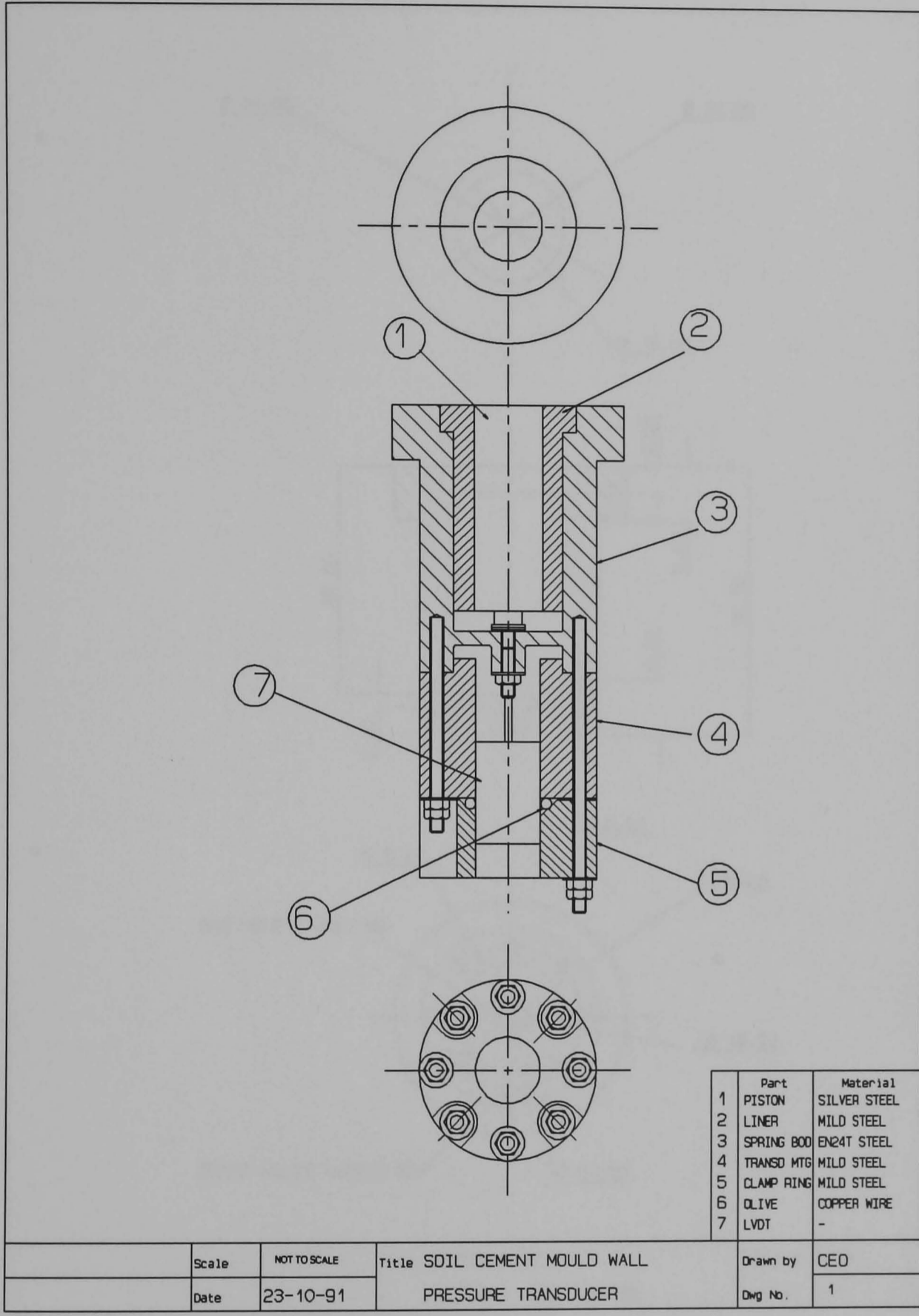

Figure E1 LVDT Transducer Assembly Drawing

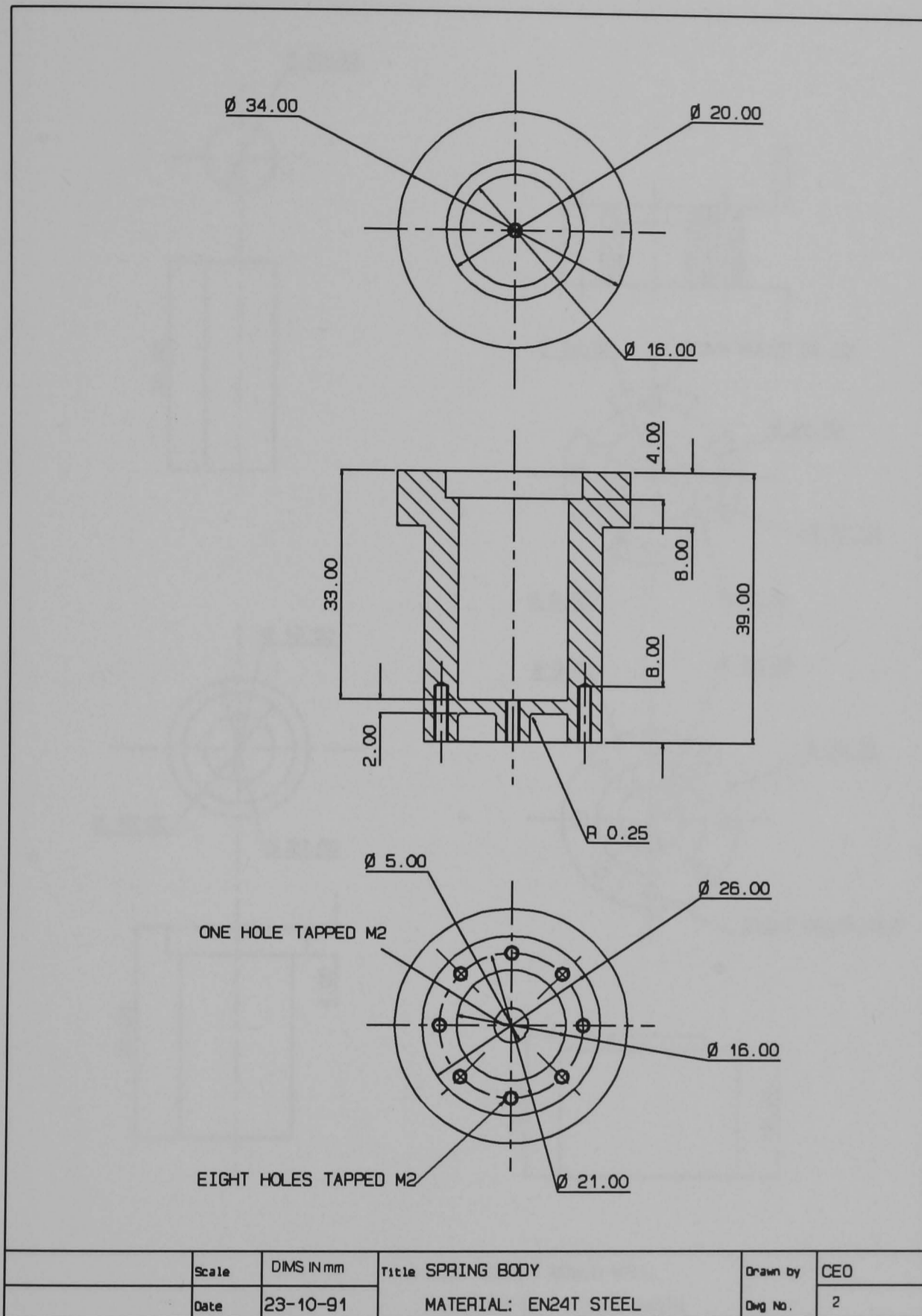

Figure E2 LVDT Transducer Spring Body

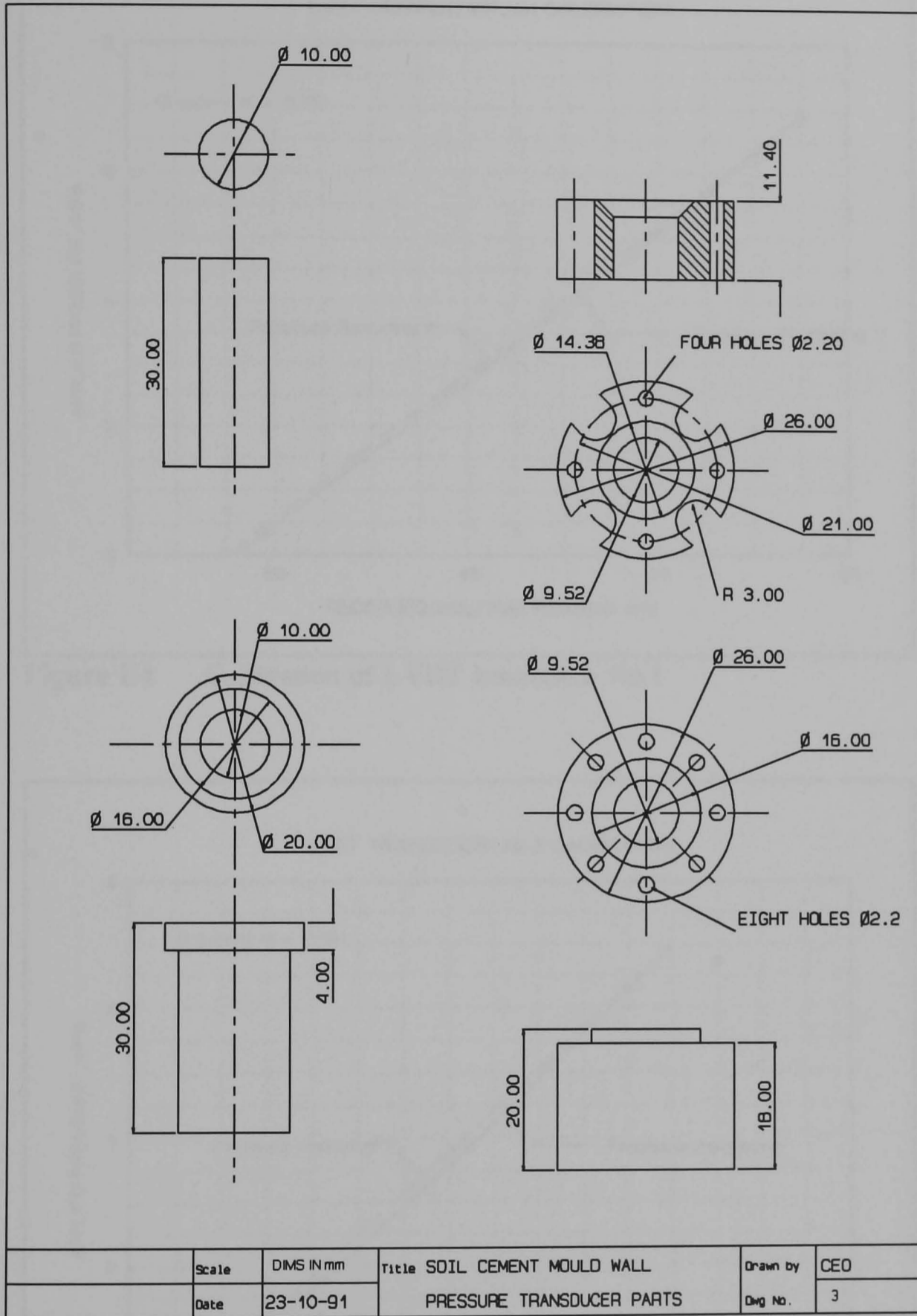

Figure E3 LVDT Transducer Parts

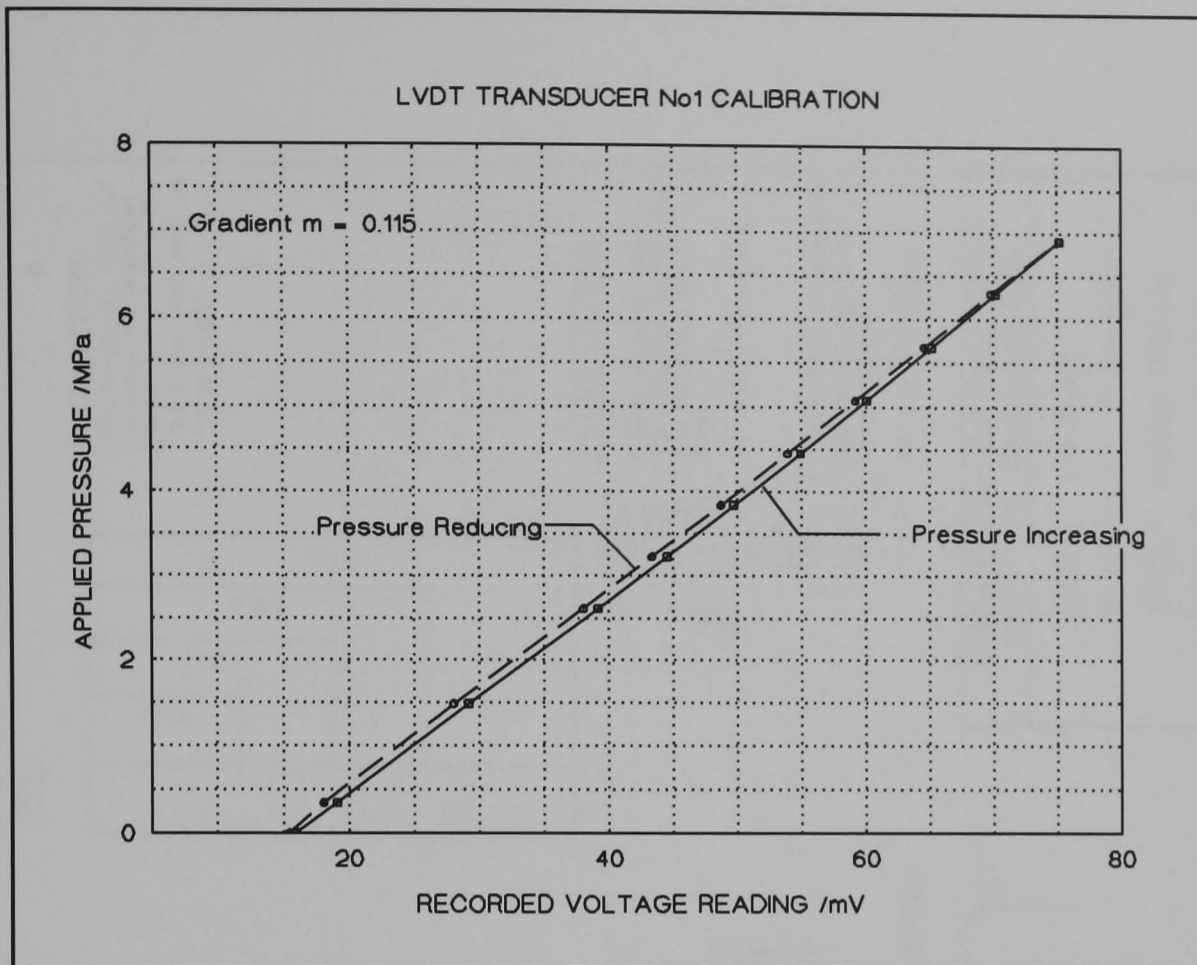

Figure E4 Calibration of LVDT transducer No.1

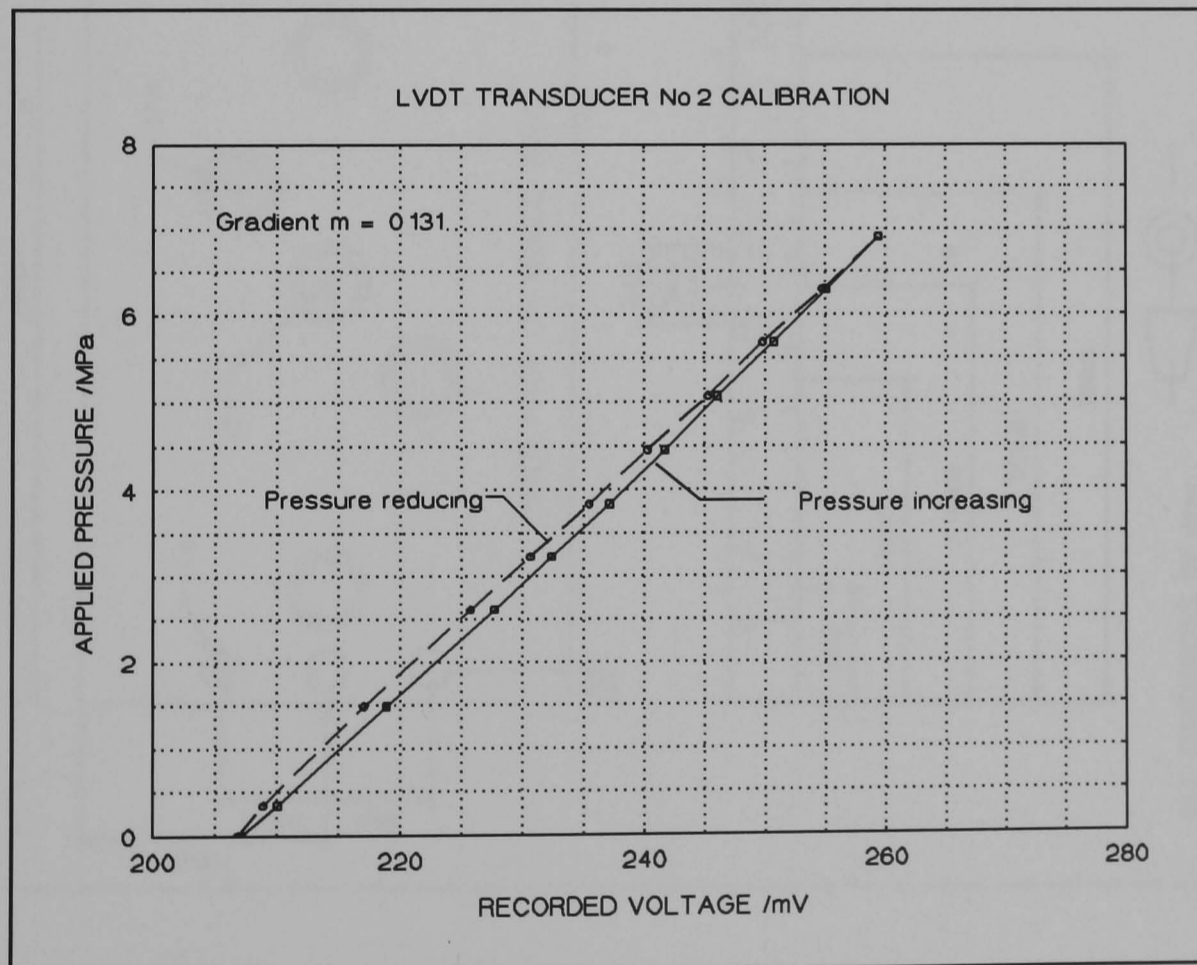
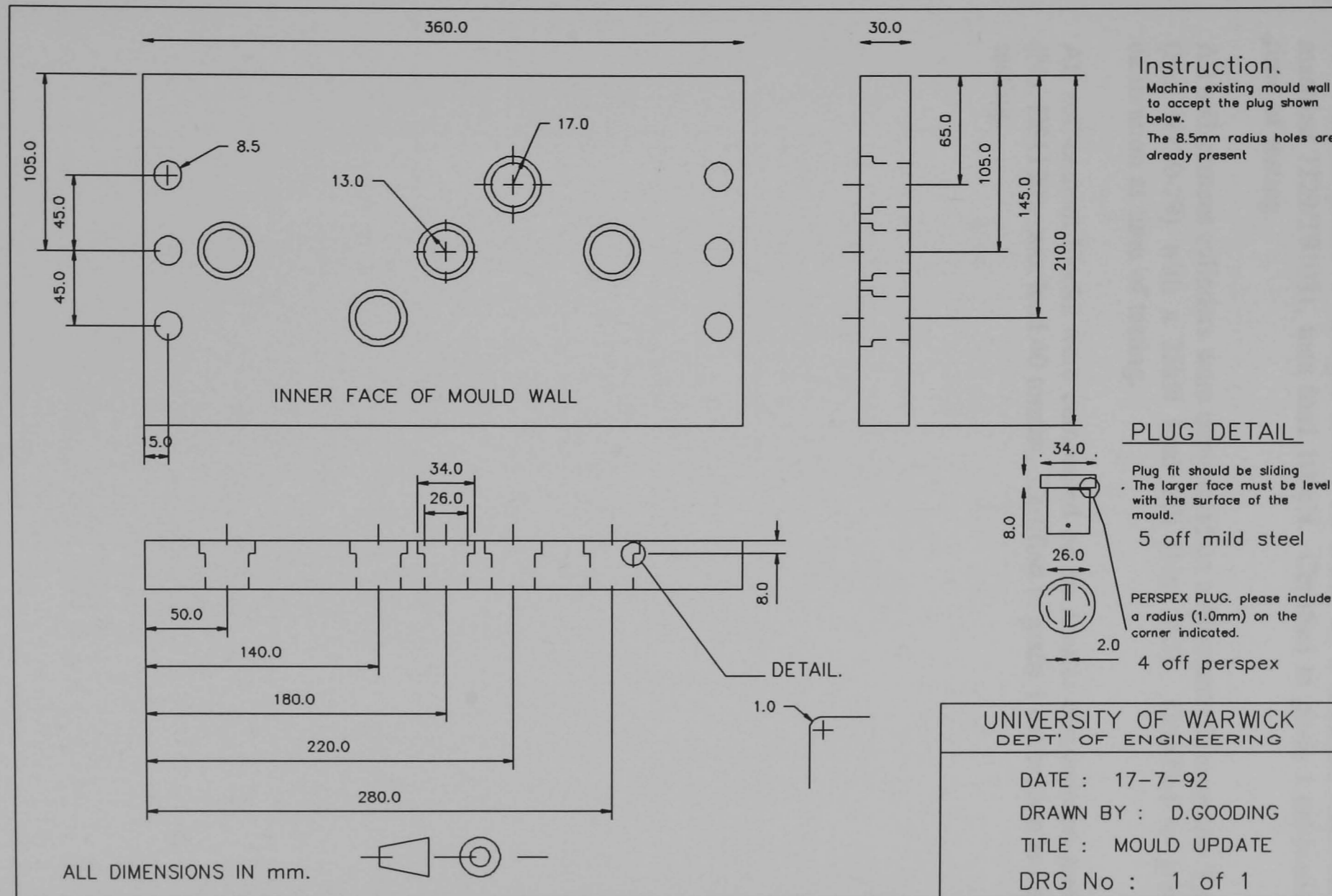

Figure E5 Calibration of LVDT transducer No.2

Figure E6

Transducer location sites in mould-side wall



TESTING MACHINE DETAILS:

- All wet compressive strength tests were made on a Denison Concrete test machine 7229/T91081, max load 100kN. Certified to grade 1 calibration at time of testing.
- All soil-cement cylinders were compacted on a Monsanto Tensometer Type E (No. N120-79) with a 25kN load cell (No. 263). Certified to grade 1 calibration at time of testing.
- All soil-cement blocks were compacted on an Amsler compression machine (No. ES1120), max load 40 tonnes. Certified to grade 1 calibration at time of testing.

APPENDIX F:

EXPERIMENTAL READINGS FOUND DURING QUASI-STATIC COMPACTION OF STANDARD-SIZE BLOCKS

Block Identification No			0		
Method of compaction			Standard datum		
Location of LVDT block 0			Centre side		
Force on top of mould /tonnes	Pressure on top of mould /MPa	Pressure on LVDT Block 0 /MPa	Height of Block 0 /mm	Lateral mould deflection (Upper) /mm	Lateral mould deflection (centre) /mm
0	0.00	0.00	140.00	0.00	0.00
5	1.20	0.58	109.75	0.04	0.25
10	2.40	1.08	107.10	0.42	0.38
15	3.62	1.52	105.35	0.55	0.50
20	4.83	2.02	104.10	0.68	0.62
25	6.03	2.43	103.00	0.80	0.75
30	7.24	2.89	102.00	0.94	0.89
35	8.45	3.24	101.10	1.07	1.03
40	9.65	3.69	100.10	1.21	1.17
35	8.45	3.69	100.10	1.21	1.17
30	7.24	3.65	100.20	1.18	1.14
25	6.03	3.63	100.25	1.13	1.09
20	4.83	3.65	100.35	1.10	1.03
15	3.62	3.35	100.46	0.90	0.92
10	2.40	2.95	100.60	0.71	0.78
5	1.20	2.24	100.85	0.46	0.56
0.1	0.02	0.32	102.40	0.09	0.10

Block Identification No			1		
Method of compaction			Standard datum		
Location of LVDT block 1			Centre side		
Force on top of mould /tonnes	Pressure on top of mould /MPa	Pressure on LVDT Block 1 /MPa	Height of Block 1 /mm	Lateral mould deflection (Upper) /mm	Lateral mould deflection (centre) /mm
0	0.00	0.00	129.00	0.00	0.00
5	1.20	0.38	109.40	0.30	0.26
10	2.40	0.78	106.80	0.48	0.39
15	3.62	1.20	105.10	0.61	0.51
20	4.83	1.63	103.90	0.71	0.62
25	6.03	2.01	102.80	0.84	0.75
30	7.24	2.45	101.80	0.95	0.86
35	8.45	2.82	101.00	1.08	0.98
40	9.65	3.22	100.01	1.22	1.12
35	8.45	3.20	100.01	1.20	1.10
30	7.24	3.18	100.08	1.17	1.08
25	6.03	3.12	100.16	1.12	1.04
20	4.83	3.04	100.26	1.06	0.98
15	3.62	2.80	100.39	0.90	0.88
10	2.40	2.45	100.55	0.66	0.78
5	1.20	1.86	100.79	0.38	0.54
0.1	0.02	0.20	102.30	0.07	0.08

Block Identification No			2		
Method of compaction			Standard datum		
Location of LVDT block 2			Mould base		
Force on top of mould /tonnes	Pressure on top of mould /MPa	Pressure on LVDT Block 2 /MPa	Height of Block 2 /mm	Lateral mould deflection (Upper) /mm	Lateral mould deflection (centre) /mm
0	0.00	0.00	134.50	0.00	0.00
5	1.20	0.73	109.32	0.37	0.29
10	2.40	1.51	106.62	0.58	0.47
15	3.62	2.27	105.02	0.71	0.57
20	4.83	3.04	103.72	0.83	0.69
25	6.03	3.87	102.62	0.94	0.79
30	7.24	4.67	101.72	1.06	0.90
35	8.45	5.50	100.82	1.18	1.01
40	9.65	6.34	99.92	1.30	1.14
35	8.45	6.07	99.92	1.30	1.14
30	7.24	5.75	99.97	1.27	1.11
25	6.03	5.31	100.04	1.23	1.08
20	4.83	4.78	100.14	1.17	1.04
15	3.62	4.07	100.27	1.02	0.92
10	2.40	3.13	100.42	0.75	0.71
5	1.20	1.94	100.65	0.45	0.40
0.1	0.02	0.04	101.12	0.07	0.08

Block Identification No			3		
Method of compaction			Standard datum		
Location of LVDT block 3			Mould base		
Force on top of mould /tonnes	Pressure on top of mould /MPa	Pressure on LVDT Block 3 /MPa	Height of Block 3 /mm	Lateral mould deflection (Upper) /mm	Lateral mould deflection (centre) /mm
0	0.00	0.00	136.00	0.00	0.00
5	1.20	0.91	110.00	0.45	0.38
10	2.40	1.75	107.10	0.61	0.51
15	3.62	2.62	105.40	0.73	0.62
20	4.83	3.47	104.00	0.85	0.73
25	6.03	4.33	102.90	0.95	0.83
30	7.24	5.18	101.95	1.07	0.93
35	8.45	5.98	101.05	1.18	1.04
40	9.65	6.82	100.20	1.29	1.14
35	8.45	6.61	99.50	1.29	1.14
30	7.24	6.31	100.20	1.27	1.13
25	6.03	5.89	100.29	1.23	1.10
20	4.83	5.36	100.40	1.17	1.07
15	3.62	4.67	100.55	1.06	0.99
10	2.40	3.72	100.72	0.81	0.80
5	1.20	2.42	100.98	0.53	0.55
0.1	0.02	0.26	101.65	0.06	0.10

Block Identification No			4		
Method of compaction			Standard datum		
Location of LVDT block 4			Lower centre side		
Force on top of mould /tonnes	Pressure on top of mould /MPa	Pressure on LVDT Block 4 /MPa	Height of Block 4 /mm	Lateral mould deflection (Upper) /mm	Lateral mould deflection (centre) /mm
0	0.00	0.00	132.00	0.00	0.00
5	1.20	0.35	109.82	0.57	0.40
10	2.40	0.71	107.10	0.74	0.51
15	3.62	1.06	105.38	0.87	0.65
20	4.83	1.43	104.05	0.98	0.76
25	6.03	1.75	102.95	1.10	0.87
30	7.24	2.10	101.95	1.22	0.98
35	8.45	2.45	101.00	1.34	1.10
40	9.65	2.81	100.08	1.46	1.22
35	8.45	2.82	100.08	1.45	1.21
30	7.24	2.81	100.17	1.43	1.19
25	6.03	2.79	100.27	1.38	1.15
20	4.83	2.76	100.40	1.32	1.10
15	3.62	2.69	100.56	1.21	0.96
10	2.40	2.54	100.75	1.02	0.87
5	1.20	1.96	101.08	0.73	0.65
0.1	0.02	0.20	101.70	0.05	0.11

Block Identification No		5	
Method of compaction		Standard datum + fast cycle	
Location of LVDT block 5		Lower centre side	
Force on top of mould /tonnes	Pressure on top of mould /MPa	Pressure on LVDT Block 5 /MPa	Height of Block 5 /mm
0	0.00	0.00	131
39.6	9.56	2.76	98.4
0.05	0.01	0.21	100.92
39.8	9.61	2.17	97.2
0.15	0.04	0.29	99.44
39.85	9.62	1.93	96.6
0.15	0.04	0.28	98.85
39.95	9.64	1.78	96.13
0.15	0.04	0.31	98.32
40.25	9.72	1.67	95.76
0	0.00	0.30	97.89
39.95	9.64	1.61	95.43
0.1	0.02	0.39	97.42
39.95	9.64	1.54	95.22
0.05	0.01	0.36	97.26
39.95	9.64	1.54	95.01
0.1	0.02	0.23	96.88
0	0.00	0.28	97.53

Block Identification No			6	
Method of compaction			Standard datum + fast cycle	
Location of LVDT No.1			Upper centre side	
Location of LVDT No.2			Mould base	
Force on top of mould /tonnes	Pressure on top of mould /MPa	Pressure on LVDT No.1 /MPa	Pressure on LVDT No.2 /MPa	Height of Block 6
0	0.00	-0.05	0.00	135.00
5	1.20	0.43	0.70	107.39
10	2.40	0.96	1.51	105.77
15	3.62	1.47	2.34	104.00
20	4.83	1.96	3.15	102.73
25	6.03	2.36	3.98	101.67
30	7.24	2.82	4.83	100.69
35	8.45	3.19	5.69	99.87
40	9.65	3.47	6.53	99.02
30	7.24	3.55	5.83	99.09
20	4.83	2.90	4.75	99.27
10	2.40	2.13	3.18	99.60
0.1	0.02	-0.02	0.07	100.50
40	9.65	2.55	6.61	98.02
0.1	0.02	0.02	0.10	99.42
40	9.65	2.14	6.71	97.37
0.1	0.02	0.02	0.09	99.79
40	9.65	1.87	6.73	96.90
0.1	0.02	-0.01	0.09	99.28
40	9.65	1.69	6.77	96.50
0.1	0.02	0.00	0.09	98.87

Block Identification No			7	
Method of compaction			Standard datum + cycle	
Location of LVDT No.1			Centre side	
Location of LVDT No.2			Mould base	
Force on top of mould /tonnes	Pressure on top of mould /MPa	Pressure on LVDT No.1 /MPa	Pressure on LVDT No.2 /MPa	Height of Block 7 /mm
0	0.00	0.00	0.00	139.38
5	1.20	0.52	0.81	109.73
10	2.40	1.00	1.67	105.85
15	3.62	1.47	2.51	105.12
20	4.83	1.91	3.32	103.73
25	6.03	2.34	4.15	102.60
30	7.24	2.77	5.05	101.60
35	8.45	3.17	5.87	100.70
40	9.65	3.55	6.66	99.86
30	7.24	3.55	5.85	99.88
20	4.83	3.50	4.77	100.06
10	2.40	2.87	3.16	100.42
0.1	0.02	0.24	0.13	102.30
40	9.65	3.38	6.84	98.76
0.1	0.02	0.21	0.11	102.31
40	9.65	3.20	6.90	98.15
0.1	0.02	0.24	0.14	100.58
40	9.65	3.18	6.89	97.69
0.1	0.02	0.21	0.09	100.12
40	9.65	3.13	6.90	97.33
0.1	0.02	0.22	0.15	99.00
0	0	0.26	0.03	100.20

Block Identification No			8	
Method of compaction			Standard datum + cycle	
Location of LVDT No.1			Lower centre side	
Location of LVDT No.2			Mould base	
Force on top of mould /tonnes	Pressure on top of mould /MPa	Pressure on LVDT No.1 /MPa	Pressure on LVDT No.2 /MPa	Height of Block 8 /mm
0	0.00	0.00	0.00	139.50
5	1.20	0.38	0.93	110.22
10	2.40	0.76	1.83	106.17
15	3.62	1.10	2.68	105.32
20	4.83	1.45	3.54	103.93
25	6.03	1.80	4.39	102.70
30	7.24	2.16	5.29	101.65
35	8.45	2.49	6.18	100.74
40	9.65	2.84	6.97	99.84
30	7.24	2.83	6.24	99.97
20	4.83	2.82	5.16	100.20
10	2.40	2.66	3.45	100.71
0.1	0.02	0.16	0.05	103.12
40	9.65	2.26	7.10	98.98
0.1	0.02	0.15	0.08	102.05
40	9.65	2.04	7.18	98.35
0.1	0.02	0.16	0.11	101.31
40	9.65	1.89	7.14	97.90
0.1	0.02	0.19	0.07	100.80
40	9.65	1.81	7.09	97.53
0.1	0.02	0.19	0.05	100.40
40	9.65	1.74	7.09	97.24
0.1	0.02	0.21	0.04	100.05
0	0.00	0.17	0.04	100.57

Block Identification No			9	
Method of compaction			Reduced friction, standard datum	
Location of LVDT No.1			Lower centre side	
Location of LVDT No.2			Mould base	
Force on top of mould /tonnes	Pressure on top of mould /MPa	Pressure on LVDT No.1 /MPa	Pressure on LVDT No.2 /MPa	Height of Block 9 /mm
0	0.00	0.00	0.00	134.00
5	1.20	0.56	0.91	110.33
10	2.40	1.05	1.76	107.43
15	3.62	1.54	2.63	105.66
20	4.83	1.98	3.60	104.25
25	6.03	2.40	4.55	103.08
30	7.24	2.86	5.52	102.07
35	8.45	3.29	6.43	101.20
40	9.65	3.61	7.41	100.30
30	7.24	3.59	5.99	100.37
20	4.83	3.48	4.35	100.70
10	2.40	3.00	2.45	101.00
0.1	0.02	0.27	0.26	103.28
40	9.65	3.23	7.25	99.20
20	4.83	3.09	4.29	99.46
40	9.65	3.27	7.25	99.02
20	4.83	3.14	4.31	99.35
40	9.65	3.29	7.23	98.93
20	4.83	3.17	4.35	99.26
40	9.65	3.29	7.27	98.86
20	4.83	3.15	4.36	99.21
40	9.65	3.30	7.26	98.79
20	4.83	3.19	4.35	99.14
0	0.00	0.31	0.33	101.80

Block Identification No			10	
Method of compaction			Reduced friction, standard datum	
Location of LVDT No.1			Upper centre side	
Location of LVDT No.2			Mould base	
Force on top of mould /tonnes	Pressure on top of mould /MPa	Pressure on LVDT 1 /MPa	Pressure on LVDT 2 /MPa	Height of Block 10 /mm
0	0.00	0.00	0.00	135.00
5	1.21	0.63	0.81	110.21
10	2.41	1.13	1.69	107.39
15	3.62	1.71	2.67	105.62
20	4.83	2.24	3.67	104.20
25	6.03	2.68	4.68	103.07
30	7.24	3.12	5.69	102.02
35	8.45	3.64	6.75	101.05
40	9.66	4.10	7.80	100.27
30	7.24	4.03	6.55	100.30
20	4.83	3.82	4.67	100.50
10	2.41	3.12	2.62	100.88
0.1	0.02	0.12	0.05	102.12
40	9.66	3.63	7.82	99.10
20	4.83	3.39	4.64	99.45
40	9.66	3.67	7.86	98.98
20	4.83	3.49	4.75	99.30
40	9.66	3.68	7.87	98.89
20	4.83	3.53	4.72	99.16
4	0.97	2.01	1.22	100.04
40	9.66	3.48	7.91	98.59
4	0.97	1.97	1.22	99.73
40	9.66	3.48	7.95	98.33
30	7.24	3.46	6.55	98.48
20.00	4.83	3.31	4.72	98.68
10.00	2.41	2.81	2.58	99.03
0.10	0.02	0.19	0.10	101.09

Block Identification No			11	
Method of compaction			1 Deg taper, standard datum	
Location of LVDT No.1			Lower centre side	
Location of LVDT No.2			Mould base	
Force on top of mould /tonnes	Pressure on top of mould /MPa	Pressure on LVDT No.1 /MPa	Pressure on LVDT No.2 /MPa	Height of Block 11 /mm
0.00	0.00	0.00	0.00	128.00
5.00	1.21	0.48	0.94	107.24
10.00	2.41	0.89	1.83	105.14
15.00	3.62	1.28	2.68	102.77
20.00	4.83	1.67	3.57	101.39
25.00	6.03	1.98	4.46	100.29
30.00	7.24	2.31	5.37	99.24
35.00	8.45	2.66	6.20	98.32
40.00	9.66	2.94	7.08	97.48
30.00	7.24	2.95	6.32	97.57
20.00	4.83	2.97	5.15	97.78
10.00	2.41	2.89	3.41	98.14
0.10	0.02	0.24	0.09	100.21
40.00	9.66	2.31	7.02	96.39
4.00	0.97	1.66	1.64	97.64
40.00	9.66	2.24	7.09	95.98
4.00	0.97	1.98	1.79	97.17
40.00	9.66	2.18	7.10	95.70
4.00	0.97	1.91	1.75	96.92
40.00	9.66	2.19	7.06	95.39
4.00	0.97	1.93	1.80	96.61
0.10	0.02	0.34	0.16	98.05
40.00	9.66	1.97	7.04	95.04
0.10	0.02	0.34	0.19	96.50
0.00	0.00	0.24	0.08	97.84

Block Identification No		12		
Method of compaction		1 Deg taper, standard datum		
Location of LVDT No.1		Centre side		
Location of LVDT No.2		Mould base		
Force on top of mould /tonnes	Pressure on top of mould /MPa	Pressure on LVDT No.1 /MPa	Pressure on LVDT No.2 /MPa	Height of Block 12 /mm
0.00	0.00	0.00	0.00	131.00
5.00	1.21	0.62	0.95	106.15
10.00	2.41	1.18	1.83	103.45
15.00	3.62	1.75	2.68	101.77
20.00	4.83	2.27	3.56	100.49
25.00	6.03	2.79	4.42	99.38
30.00	7.24	3.24	5.33	98.50
35.00	8.45	3.71	6.22	97.62
40.00	9.66	4.17	7.06	96.83
30.00	7.24	4.04	6.20	96.91
20.00	4.83	3.70	5.01	97.06
10.00	2.41	2.96	3.24	97.30
0.10	0.02	0.30	0.16	98.85
40.00	9.66	3.72	6.97	95.52
4.00	0.97	1.95	1.65	96.49
40.00	9.66	3.77	6.97	95.18
4.00	0.97	2.03	1.72	96.12
40.00	9.66	3.79	6.94	94.90
4.00	0.97	2.08	1.73	95.83
40.00	9.66	3.78	6.93	94.71
4.00	0.97	2.09	1.76	95.61
0.10	0.02	0.39	0.20	97.03
40.00	9.66	3.60	6.98	94.32
0.10	0.02	0.42	0.17	96.51
0.00	0.00	0.15	0.07	97.85

Block Identification No		14		
Method of compaction		5 Deg taper, standard datum		
Location of LVDT No.1		Lower centre side		
Location of LVDT No.2		Mould base		
Force on top of mould /tonnes	Pressure on top of mould /MPa	Pressure on LVDT No.1 /MPa	Pressure on LVDT No.2 /MPa	Height of Block 14 /mm
0.00	0.00	0.00	0.00	128.00
5.00	1.21	0.63	0.77	94.00
10.00	2.41	1.18	1.63	92.00
15.00	3.62	1.75	2.62	89.00
20.00	4.83	2.29	3.61	87.00
25.00	6.03	2.74	4.59	86.00
30.00	7.24	3.20	5.61	85.00
35.00	8.45	3.62	6.55	84.00
40.00	9.66	4.08	7.49	83.00
30.00	7.24	4.02	6.43	83.00
20.00	4.83	3.85	4.92	83.00
10.00	2.41	3.37	3.00	83.00
0.10	0.02	0.42	0.00	85.00
40.00	9.66	3.53	7.35	82.00
4.00	0.97	2.43	1.42	83.00
40.00	9.66	3.47	7.34	82.00
4.00	0.97	2.49	1.43	83.00
0.10	0.02	0.42	0.00	84.00
0.00	0.00	0.26	0.00	84.00

Block Identification No			15	
Method of compaction			Floating mould, double sided	
Location of LVDT No.1			Centre side	
Location of LVDT No.2			Mould base	
Force on top of mould /MPa	Pressure on top of mould /MPa	Pressure on LVDT No.1 /MPa	Pressure on LVDT No.2 /MPa	Height of Block 15 /mm
0.00	0.00	0.00	0.00	151.00
0.50	0.12	0.06	0.08	121.42
1.00	0.24	0.11	0.21	115.99
2.00	0.48	0.25	0.40	112.99
3.00	0.72	0.37	0.60	111.29
5.00	1.21	0.61	0.98	109.29
10.00	2.41	1.17	1.87	106.59
20.00	4.83	2.27	3.84	103.59
30.00	7.24	3.31	5.78	101.39
40.00	9.66	4.40	7.87	99.49
0.10	0.02	0.34	0.15	101.89
40.00	9.66	3.96	7.82	98.29
0.10	0.02	0.39	0.14	100.77
40.00	9.66	3.71	7.75	97.74
0.10	0.02	0.37	0.12	100.10

Block Identification No			16	
Method of compaction			Floating mould, double sided	
Location of LVDT No.1			Centre side	
Location of LVDT No.2			Mould base	
Force on top of mould /MPa	Pressure on top of mould /MPa	Pressure on LVDT No.1 /MPa	Pressure on LVDT No.2 /MPa	Height of Block 16 /mm
0.00	0.00	0.00	0.00	150.11
0.50	0.12	0.06	0.08	120.53
1.00	0.24	0.11	0.21	115.10
2.00	0.48	0.26	0.39	112.10
3.00	0.72	0.38	0.58	110.40
5.00	1.21	0.63	0.95	108.40
10.00	2.41	1.21	1.81	105.70
20.00	4.83	2.35	3.73	102.70
30.00	7.24	3.42	5.62	100.50
40.00	9.66	4.54	7.65	98.60
0.10	0.02	0.36	0.14	101.00
40.00	9.66	4.08	7.60	97.40
0.10	0.02	0.41	0.14	99.88
40.00	9.66	3.83	7.53	96.85
0.10	0.02	0.38	0.12	99.21

APPENDIX G:

COMPRESSIVE STRENGTH VALUES CONCERNING SECTIONED STANDARD-SIZE BLOCKS STABILISED WITH 5% CEMENT

7-day compressive strength data for non-sectioned block halves formed by single and floating mould double-sided compaction. Each block was made from *Soil-A* with 8% moisture content and 5% cement content by dry weight.

Compaction method	Block ID	Dimension x /m	Dimension y /m	Compression area /m ²	strength /kN	Strength /MPa
single	c1a	0.1402	0.1280	0.0179	48.4	2.70
single	c1b	0.1402	0.1433	0.0201	58.3	2.90
single	c2a	0.1402	0.1455	0.0204	58.5	2.87
single	c2b	0.1402	0.1425	0.0200	56.9	2.85
single	c4a	0.1402	0.1441	0.0202	56.7	2.81
single	c4b	0.1402	0.1340	0.0188	54.5	2.90
double	cd2a	0.1402	0.1427	0.0200	60.3	3.01
double	cd2b	0.1402	0.1453	0.0204	62.7	3.08
double	cd3a	0.1402	0.1440	0.0202	58.4	2.89
double	cd3b	0.1402	0.1441	0.0202	62.2	3.08
double	cd4a	0.1402	0.1333	0.0187	57.5	3.08
double	cd4b	0.1402	0.1500	0.0210	65.9	3.13

Compaction method: **single** represents single-sided forming under standard datum conditions

Double represents floating-mould double-sided compaction

7-Day compressive strength data for sectioned block halves. Section location key overleaf

Section location	Block cd1a	Block cd1b	Block **c3a**	Block c3b	Avg all cd	Avg all c
1TF	4.08	4.18	6.45	4.25	4.13	5.35
1MF	4.22	3.72	4.58	3.69	3.97	4.13
1BF	3.78	4.62	3.73	3.16	4.20	3.45
1TC	4.11	3.78	4.81	3.67	3.94	4.24
1MC	3.74	3.93	4.34	3.73	3.84	4.04
1BC	3.79	3.96	3.62	3.68	3.87	3.65
1TR	3.60	3.89	4.13	4.37	3.75	4.25
1MR	3.31	3.49	3.93	3.61	3.40	3.77
1BR	4.05	4.23	3.21	3.01	4.14	3.11
2TF	3.79	3.66	4.01	3.15	3.73	3.58
2MF	3.37	3.92	4.73	3.29	3.64	4.01
2BF	3.61	3.99	4.35	2.92	3.80	3.63
2TC	3.87	3.92	3.85	3.13	3.89	3.49
2MC	3.90	3.62	4.06	3.10	3.76	3.58
2BC	3.47	3.65	4.02	3.70	3.56	3.86
2TR	3.99	3.78	4.29	3.18	3.88	3.73
2MR	3.68	3.60	4.03	3.27	3.64	3.65
2BR	4.00	3.62	3.28	2.77	3.81	3.03
3TF	3.45	4.05	4.02	3.49	3.75	3.75
3MF	3.73	3.75	4.17	3.32	3.74	3.74
3BF	3.64	3.91	3.58	2.67	3.77	3.13
3TC	3.64	4.06	3.86	3.38	3.85	3.62
3MC	3.75	3.66	3.81	3.11	3.71	3.46
3BC	3.95	3.69	4.07	3.47	3.82	3.77
3TR	4.07	3.61	3.51	3.16	3.84	3.33
3MR	3.69	3.57	4.08	3.16	3.63	3.62
3BR	3.73	3.58	3.39	2.61	3.66	3.00
avg all sections	3.78	3.83	4.07	3.33	3.80	3.70

Each block was compacted at 8% moisture content, stabilised with 5% cement. Those indexed with "c" were single sided while those with "cd" were double sided. After 7 days of curing the blocks were soaked in water for 16 hours (see note) and cut into sections (as shown in Figure G). The sections were capped with 6mm fibre board prior to testing for compressive strength.

Note: block half c3a was inadvertently soaked for only five hours, all other sections were soaked for 16 hours

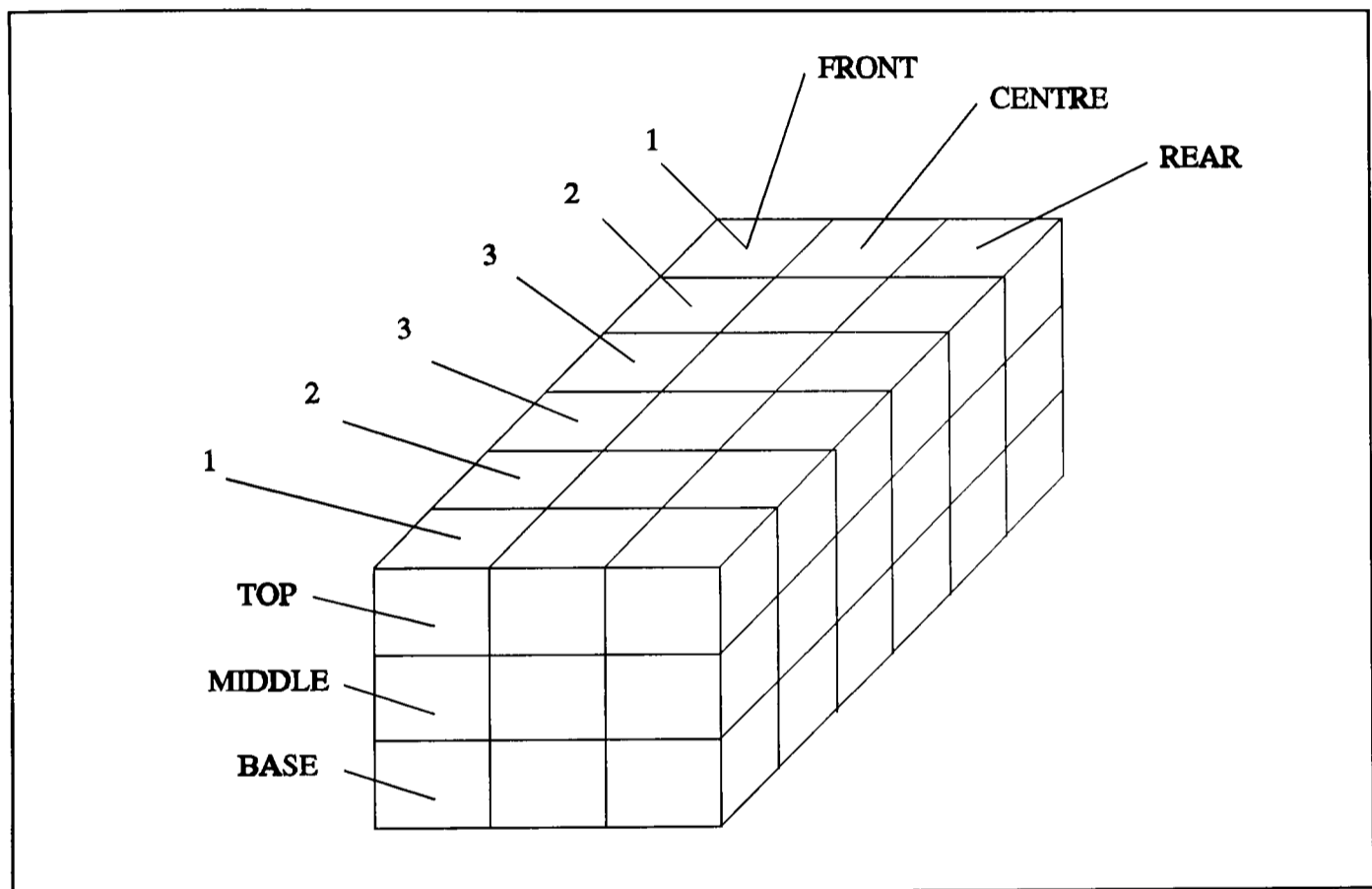

Figure G Schematic diagram to illustrate the number sequence used to identify the block sections tested for compressive strength

APPENDIX H:

EXPERIMENTAL DATA USED TO CONSTRUCT THE PRESSURE-CEMENT-STRENGTH RELATION

Sample ID: r represents repeated experiment
 first two digits represent the applied compaction force in kN
 second two digits represent cement content used, % by dry mass
 final digit represents number of cylinder in series, 1, 2 or 3

Cured strength: Is 7-day cured compressive strength, tested after 16 hour immersion in water.

Sample ID No	Applied force /kN	Cement content /%	Fill mass /g	Eject mass /g	Ejected length /mm	Ejected bulk density /kg/m ³	Cured strength /kN	Cured strength /MPa
20111	20	11	453.6	453.26	108.45	2175	8.39	4.37
20112	20	11	453.6	451.92	108.90	2160	7.84	4.08
20113	20	11	453.6	453.12	108.50	2174	8.90	4.63
r2091	20	9	453.6	453.49	109.00	2165	6.91	3.60
r2092	20	9	453.6	453.32	109.00	2165	7.17	3.73
r2093	20	9	453.6	453.38	109.00	2165	7.13	3.71
20091	20	9	453.6	453.25	108.60	2172	8.58	4.47
20092	20	9	453.6	450.46	108.70	2157	8.65	4.50
20093	20	9	453.6	453.32	108.90	2167	8.10	4.22
20071	20	7	453.6	453.50	110.30	2140	4.85	2.52
20072	20	7	453.6	452.99	110.10	2141	4.88	2.54
20073	20	7	453.6	453.38	110.50	2136	4.64	2.42
20051	20	5	453.6	453.20	110.80	2129	3.33	1.73
20052	20	5	453.6	453.18	111.25	2120	2.95	1.54
20053	20	5	453.6	452.49	110.90	2124	3.12	1.62
20031	20	3	453.6	452.86	111.45	2115	2.53	1.32
20032	20	3	453.6	453.24	111.60	2114	1.72	0.90
20033*	20	3	408.5	406.90	101.60			

Continued overleaf

Sample ID No	Applied force /kN	Cement content /%	Fill mass /g	Eject mass /g	Ejected length /mm	Ejected bulk density /kg/m ³	Cured strength /kN	Cured strength /MPa
r16111	15.5	11	453.6	453.45	110.00	2146	8.63	4.49
r16112	15.5	11	453.6	453.35	110.00	2145	8.77	4.56
r16113	15.5	11	453.6	453.35	110.00	2145	8.32	4.33
16111	15.5	11	453.6	453.18	111.60	2114	8.71	4.53
16112	15.5	11	453.6	453.10	110.45	2135	8.26	4.30
16113	15.5	11	453.6	453.34	110.70	2131	7.77	4.04
r1691	15.5	9	453.6	453.50	111.00	2126	7.14	3.72
r1692	15.5	9	453.6	453.40	110.00	2145	6.49	3.38
r1693	15.5	9	453.6	453.30	111.25	2121	5.97	3.11
16091	15.5	9	453.6	452.95	111.20	2120	7.46	3.88
16092	15.5	9	453.6	453.22	111.35	2118	6.24	3.25
16093	15.5	9	453.6	453.21	111.30	2119	5.81	3.02
16071	15.5	7	453.6	453.18	111.80	2110	4.50	2.34
16072	15.5	7	453.6	453.08	111.75	2110	4.58	2.38
16073	15.5	7	453.6	453.50	112.20	2104	3.78	1.97
16051	15.5	5	453.6	453.42	113.10	2087	2.75	1.43
16052	15.5	5	453.6	453.38	113.45	2080	2.85	1.48
16053	15.5	5	453.6	453.57	113.45	2081	2.72	1.42
16031	15.5	3	453.6	452.96	113.50	2077	1.52	0.79
16032	15.5	3	453.6	453.57	113.80	2074	1.56	0.81
16033	15.5	3	453.6	453.41	113.70	2076	1.44	0.75

Continued overleaf

Sample ID No	Applied force /kN	Cement content /%	Fill mass /g	Eject mass /g	Ejected length /mm	Ejected bulk density /kg/m ³	Cured strength /kN	Cured strength /MPa
12111	12	11	453.6	453.60	112.40	2100	6.88	3.58
12112	12	11	453.6	453.50	112.25	2103	7.43	3.87
12113	12	11	453.6	453.24	112.70	2093	6.92	3.60
12091	12	9	453.6	453.12	112.55	2095	4.33	2.25
12092	12	9	453.6	453.60	112.80	2093	5.67	2.95
12093	12	9	453.6	453.31	112.90	2090	5.60	2.91
12071	12	7	453.6	453.17	113.30	2082	3.87	2.01
12072	12	7	453.6	453.32	113.50	2079	4.00	2.08
12073	12	7	453.6	453.35	113.40	2081	4.04	2.10
12051	12	5	453.6	453.20	114.05	2068	2.37	1.23
12052	12	5	453.6	453.34	114.20	2066	2.47	1.29
12053	12	5	453.6	453.23	114.35	2063	2.60	1.35
12031	12	3	453.6	453.23	115.20	2048	1.54	0.80
12032	12	3	453.6	453.39	115.15	2049	1.56	0.81
12033	12	3	453.6	453.38	115.55	2042	1.54	0.80
8111	8	11	453.6	453.37	114.35	2064	6.22	3.24
8112	8	11	453.6	453.39	114.30	2065	6.55	3.41
8113	8	11	453.6	453.30	114.35	2063	6.64	3.46
8091	8	9	453.6	453.60	114.80	2057	4.84	2.52
8092	8	9	453.6	453.25	115.30	2046	5.18	2.70
8093	8	9	453.6	453.22	115.30	2046	5.01	2.61
8071	8	7	453.6	453.37	115.50	2043	3.88	2.02
8072	8	7	453.6	453.09	115.65	2039	3.71	1.93
8073	8	7	453.6	453.42	115.65	2041	2.94	1.53
8051	8	5	453.6	452.59	115.70	2036	2.35	1.22
8052	8	5	453.6	453.36	116.25	2030	2.29	1.19
8053	8	5	453.6	453.37	116.25	2030	2.31	1.20
8031	8	3	453.6	453.32	116.70	2022	1.36	0.71
8032	8	3	453.6	453.52	116.80	2021	1.34	0.70
8033	8	3	453.6	453.36	116.95	2018	1.17	0.61

Continued overleaf

Sample ID No	Applied force /kN	Cement content /%	Fill mass /g	Eject mass /g	Ejected length /mm	Ejected bulk density /kg/m ³	Cured strength /kN	Cured strength /MPa
4111	4	11	453.6	453.55	118.00	2001	5.52	2.87
4112	4	11	453.6	453.56	118.25	1996	5.37	2.79
4113	4	11	453.6	452.73	117.70	2002	5.13	2.67
4091	4	9	453.6	453.46	118.90	1985	3.93	2.05
4092	4	9	453.6	453.54	119.15	1981	3.99	2.08
4093	4	9	453.6	453.46	119.50	1975	4.04	2.10
4071	4	7	453.6	453.53	118.85	1986	2.63	1.37
4072	4	7	453.6	453.22	118.90	1984	2.97	1.55
4073	4	7	453.6	453.56	119.50	1975	3.04	1.58
4051	4	5	453.6	453.30	119.50	1974	1.94	1.01
4052	4	5	453.6	453.38	119.90	1968	1.82	0.95
4053	4	5	453.6	453.38	119.90	1968	1.92	1.00
4031	4	3	453.6	453.60	120.85	1954	1.15	0.60
4032	4	3	453.6	453.32	120.90	1952	1.13	0.59
4033	4	3	453.6	453.29	121.10	1948	0.93	0.48
2111	2	11	453.6	453.24	121.55	1941	4.10	2.13
2112	2	11	453.6	453.38	121.75	1938	3.82	1.99
2113	2	11	453.6	453.21	121.85	1936	4.18	2.18
2091	2	9	453.6	453.47	123.00	1919	2.89	1.50
2092	2	9	453.6	453.35	122.50	1926	2.94	1.53
2093	2	9	453.6	453.28	122.80	1921	2.95	1.54
2071	2	7	453.6	453.63	121.60	1942	2.69	1.40
2072	2	7	453.6	453.39	122.20	1931	2.49	1.30
2073	2	7	453.6	453.31	122.35	1928	2.09	1.09
2051	2	5	453.6	453.44	122.25	1931	1.54	0.80
2052	2	5	453.6	453.50	122.30	1930	1.63	0.85
2053	2	5	453.6	453.48	122.25	1931	1.56	0.81
2031	2	3	453.6	453.51	122.60	1925	0.92	0.48
2032	2	3	453.6	453.50	122.75	1923	0.87	0.45
2033	2	3	453.6	453.45	123.00	1919	0.95	0.49

APPENDIX I:

DESCRIPTION OF THE SCRATCH TESTING APPARATUS

Figure K (overleaf) shows the scratch testing apparatus used to scratch the surface of cured blocks. It consisted of a mild steel 10mm diameter rod with a hardened blunt point (included angle 45°) contained within a stainless steel guide tube (11mm internal diameter). Above the scratch rod four calibrated compression springs were installed giving a combined spring constant of 0.072 kg/mm. The combined spring length was long compared to the scratch depth and hence the load applied by the scratch rod was approximately constant. The tube containing the scratch rod was rigidly mounted on an aluminium block which was free to slide along two parallel steel guide bars. The steel guide bars were screwed into two mounting blocks and secured with locking nuts. The preload on the springs could be adjusted by means of the threaded preload adjuster situated on the upper end of the scratch rod guide tube.

A test was conducted by rigidly clamping the scratch tester a fixed distance above the surface of the block to be scratched, ensuring that it was parallel to the block surface. Once the preload had been set the force applied by the scratch tester was determined by the distance between the unit and the block face. For all of the tests conducted in this thesis the force applied was 21.2N (2.16 kg). Once correctly set up the scratch rod was moved over the face of the block to produce a scratch. The depth of the scratch was then measured using a dial gauge. The tip of the dial gauge was modified such that it record the full depth of the scratch without touching the edges.

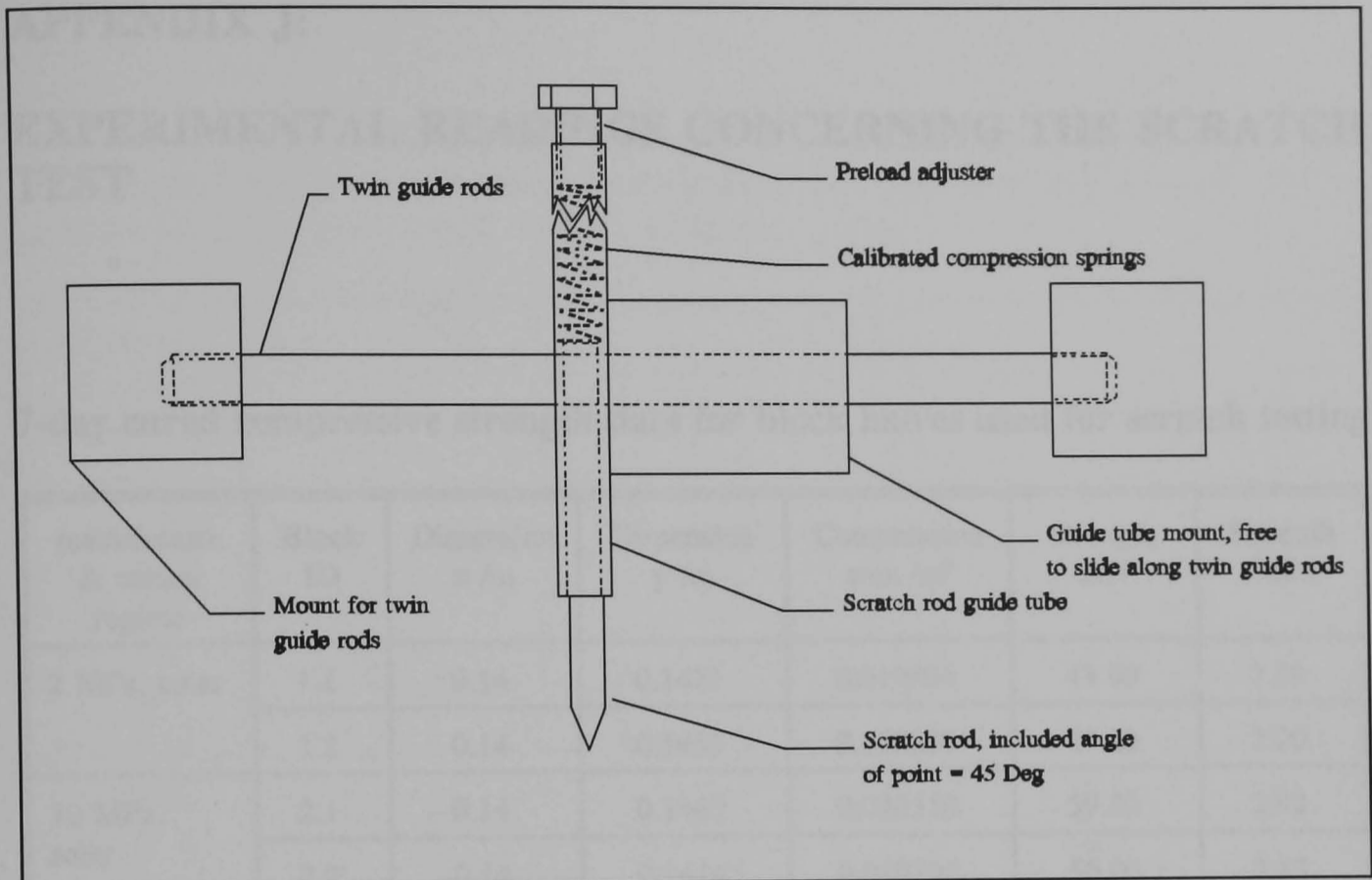

Figure I Schematic illustration of scratch testing apparatus

APPENDIX J:

EXPERIMENTAL READINGS CONCERNING THE SCRATCH TEST

7-day cured compressive strength data for block halves used for scratch testing

manufacture & curing regime	Block ID	Dimension x /m	Dimension y /m	Compression area /m ²	strength /kN	Strength /MPa
2 MPa, solar	1.1	0.14	0.1421	0.019894	43.60	2.19
	1.2	0.14	0.1455	0.020370	44.80	2.20
10 MPa, solar	2.1	0.14	0.1465	0.020510	59.80	2.92
	2.2	0.14	0.1414	0.019796	56.00	2.83
10 MPa, solar	6.1	0.14	0.1458	0.020405	50.00	2.45
	6.2	0.14	0.1420	0.019880	48.10	2.42
10 MPa, normal	N1.1	0.14	0.1439	0.020143	61.50	3.05
	N1.2	0.14	0.1439	0.020143	70.90	3.52
2 MPa, normal	N2.1	0.14	0.1439	0.020139	56.20	2.79
	N2.2	0.14	0.1439	0.020139	58.50	2.90

Key to tables in Appendix J

Manufacture & curing regime: Indicates compaction pressure used during forming and subsequent curing regime

Block ID: Block identification, each whole scratched block was cut in two before testing for compressive strength

Dimension x & y: Dimensions of block face subjected to compression loading

Compression area: Area of block over which compression applied during compressive strength testing

Strength: Largest load or pressure sustained prior to failure, blocks cured for 7-days (soaked in water for 16 hours prior to testing)

Raw scratch depth data for the two longest block sides (data is not squared). The depth of each scratch was recorded in three separate locations along its length. Three separate scratches were made on each block face tested.

manufacture & curing regime	side 1			side 2		
	scratch 1 /mm	scratch 2 /mm	scratch 3 /mm	scratch 1 /mm	scratch 2 /mm	scratch 3 /mm
2 MPa solar Block 1	3.30	3.10	4.40	2.80	2.90	3.65
	3.20	3.35	4.25	2.60	2.60	2.90
	3.30	3.35	4.00	2.60	2.00	2.75
	avg	3.27	3.27	4.22	2.67	2.50
10 MPa solar Block 2	2.60	3.00	3.60	3.30	2.65	2.65
	2.50	2.75	3.50	2.45	2.45	2.55
	1.55	1.80	2.90	2.00	2.20	2.15
	avg	2.22	2.52	3.33	2.58	2.43
10 MPa solar Block 6	2.90	2.90	3.55	3.30	3.40	3.30
	2.55	2.70	3.20	2.90	2.90	2.60
	2.20	1.90	2.85	1.70	2.15	1.85
	avg	2.55	2.50	3.20	2.63	2.82
AVG 10 MPa solar	2.38	2.51	3.27	2.61	2.63	2.52
10 MPa normal Block N1	0.88	0.60	0.98	0.75	0.80	0.94
	0.70	0.81	0.73	0.91	1.02	1.03
	0.73	0.50	0.40	0.70	1.00	1.18
	AVG	0.72	0.64	0.70	0.79	0.94
2 MPa normal Block N2	0.88	0.60	1.10	1.35	0.65	1.10
	0.72	0.61	0.90	1.10	0.80	1.10
	0.78	0.50	0.92	0.80	0.52	1.25
	AVG	0.79	0.57	0.97	1.08	0.66

Raw scratch depth data for block top and base (data is not squared). The depth of each scratch was recorded in three separate locations along its length. Three separate scratches were made on each block face tested.

manufacture & curing regime	top			base		
	Scratch 1 /mm	Scratch 2 /mm	Scratch 3 /mm	scratch 1 /mm	Scratch 2 /mm	Scratch 3 /mm
2 MPa solar Block 1	4.10	3.35	4.15	2.40	2.30	2.30
	3.50	2.70	3.75	2.35	1.90	2.15
	2.10	2.15	2.80	1.90	1.80	1.70
avg	3.23	2.73	3.57	2.22	2.00	2.05
10 MPa solar Block 2	2.90	2.55	2.30	1.60	1.40	1.90
	2.55	2.25	2.25	1.50	1.50	1.85
	1.75	1.65	1.75	1.25	1.40	1.45
avg	2.40	2.15	2.10	1.45	1.43	1.73
10 MPa solar Block 6	2.90	2.65	3.20	2.80	2.10	2.90
	2.60	2.70	2.80	2.50	1.85	2.80
	2.20	2.25	2.10	2.30	2.10	2.80
avg	2.57	2.53	2.70	2.53	2.02	2.83
AVG 10 MPa solar	2.48	2.34	2.40	1.99	1.73	2.28
10 MPa normal Block N1	1.80	1.42	1.65	1.70	1.74	1.45
	1.70	1.62	1.95	1.70	1.83	1.55
	1.80	1.45	1.90	1.70	1.85	1.52
AVG	1.77	1.50	1.83	1.70	1.81	1.51
2 MPa normal Block N2	1.80	1.45	1.60	2.30	2.34	2.08
	1.98	1.60	1.80	2.80	2.85	3.00
	2.20	2.16	2.20	3.20	3.18	3.43
AVG	1.99	1.74	1.87	2.77	2.79	2.84

APPENDIX K:

DESCRIPTION OF THE EXPERIMENTAL RIG USED FOR IMPACT COMPACTION

Figure K1 to K8 show the dimensions and locations of the impacting assembly parts. The external safety cage is not shown. The external safety cage fully enclosed the impacting assembly. It was made from 22 gauge mild steel sheeting and formed a rigid box 1.5m high. Access to the impacting assembly was made by opening a door in the outer safety cage. This door was secured by means of a long bolt (500mm). Two micro-switches were in place on this door, one to sense the location of the door bolt and one to sense the location of the door (see circuit diagram Figure K9). Both of these switches were closed when the door was shut and bolted. If the door was moved one or both of these switches would open and disconnect the current to the electromagnetic lifting device, causing the impactor weight to immediately disconnect and fall safely within the guide pipe.

A type L7 electromagnet (Boxmag-rapid Ltd, Aston. 50 mm diameter with 3 fixing holes M5 x M5 & fly leads) was attached to the arm of the pneumatic ram. This was operated from a 24V dc power supply and produced a lifting force of 700N. The combined control and safety circuit is shown in Figure K9). The impactor guide tube was 98mm ID UPVC high pressure plastic water pipe. It was drilled with multiple (finger proof) vent holes both to act as a system of vents to allow air to escape in front of the falling impactor mass and to allow the disconnection-position sensor to be located. The disconnection-position sensor was inserted such that the top of the impactor being lifted would touch it at the point at which disconnection was required.

The pneumatic ram was a Bosch double-stroke double-cushioned ram (Bosch Part No 0822 221 0/2000) which was operated via a variable flow plate valve which allowed the rate of movement of the ram to be controlled. Control and adjustment of the ram movement were made manually

The impactor masses used by this apparatus were 23.35, 35.00 and 46.80 kg. These were made from mild steel, external diameter 96mm.

A full Risk Assessment was conducted, according to the directions of the Health and Safety Executive, during the design of this equipment and a Safe Scheme of work produced (both are included below).

RISK ASSESSMENT

A risk assessment has been conducted in accordance with the schedule indicated by the Health and Safety Executive. The point pertinent to the impact rig have been dealt with below.

1. *Agents present which may be hazardous to health.* Free falling weights of up to 45kg. Low voltage electrics (24V dc)
2. *Foreseeable health hazards from these agents.* None to either operator or bystanders when used in accordance with the safe scheme of work.
 - a) During testing any free falling weights are contained within a double safety cage fitted with electronic safety cutouts. The shortest time between opening the outer cage door and encroaching on the weight impact area is significantly greater than the fall time for the weight (<0.5 second) under every circumstance. The rig can not be operated from inside the safety cage and must not be operated from outside with personnel inside the safety cage.
 - b) During test set-up the weights may be changed only by the use of the designated certified lifting apparatus.

- c) The electric supply used to power the electromagnet and supply the safety cutout switches is 24 Volts dc. The maximum current used is 200mA. This is not hazardous to humans.
- 3. *Risk under the anticipated conditions of use.* None.
- 12. *Surveillance.* No reliance will or should be placed on surveillance to prevent risk of accident.

SAFE SCHEME OF WORK

General

1. The rig must not be operated with personnel inside the safety cage.
2. The operator must wear safety shoes.
3. The rig may only be operated by authorised personnel.

Changing the impact mass if mass is greater than 5 kg

1. The impact mass (rammer) will be lifted from its holder and transported to the test rig base using only the yellow counter balanced hoist in conjunction with the certified coupling device.
2. The rammer will be slid into position on the impact base. The operator will leave the safety cage, closing and bolting the door.
3. With the door closed the electromagnet may be activated and the pneumatic ram lowered onto the rammer.
4. The pneumatic ram will then be raised, lifting the rammer to its safe rest position and the securing bolt located.
5. The rammer will be lowered full onto the safe rest securing bolt and the electromagnet deactivated.
6. The rammer is now secure and access to the safety cage is permitted.

Testing procedure

1. The rammer will be in the safe rest position at the start of each test.
2. The soil mould will be filled and secured to the impact base by means of the clamps provided.
3. The rigid mass guide will be fitted and secured by means of the lower locating collar and upper tie.
4. The operator will leave the safety cage, closing and bolting the door.
5. The electromagnet will be activated and the pneumatic ram used to lift the rammer off the safe rest bolt.
6. The safe rest bolt will be removed.
7. The pneumatic ram will be raised until the microswitch automatically decouples the rammer and allows it to free fall onto the soil sample. Once the rammer is decoupled the electromagnet is automatically reset to magnetised
8. Sections five through to seven may be repeated the desired number of times until the test is complete.
9. The pneumatic ram will then be raised, lifting the rammer to its safe rest position and the securing bolt located.
10. The rammer will be lowered full onto the safe rest securing bolt and the electromagnet deactivated.
11. The rammer is now secure and access to the safety cage is permitted to remove the lower rigid guide and compacted soil sample.

Safety features.

1. During testing the rammer is completely enclosed by a rigid guide pipe within the safety cage.
2. During any rammer lifting operation the rammer is contained within the safety cage.

3. During any rammer lifting operation the outer safety cage must be closed and secured or the electromagnet will not activate.
4. If for any reason the safety cage door is opened during a rammer lifting operation the electromagnet will deactivate and the rammer will free fall to the ground.
5. The safety cage securing bolt travel is sufficiently long that the door may not be opened before the rammer hits the ground.
6. In the event of an electrical power failure the electromagnet will decouple and the rammer will free fall, either within the confines of the rigid guide tube or onto the impact base. In either case there is no risk to personnel see 2 above.
7. In the event of a pneumatic main failure the pneumatic ram will slowly lower until any mass being lifted rests either on the ground or on the safe rest securing bolt.
8. The outer safety cage is made from 22 gauge mild steel and stands 1.5m high. It is not possible to reach over the safety cage and encroach on the impact area. The steel is sufficiently thick/rigid to contain any material which might be ejected from the moulding area if the rammer were to hit the mould or the impact base out of true.
9. The inner rigid mass guide is made from high pressure UPVC piping which is capable of restraining the heaviest rammer (45kg). The piping is drilled to allow the escape of air under the dropping rammer. These holes are too small to allow finger access (10mm diameter).
10. The safe rest securing bolt is three times stronger than required to support the 47 kg rammer.

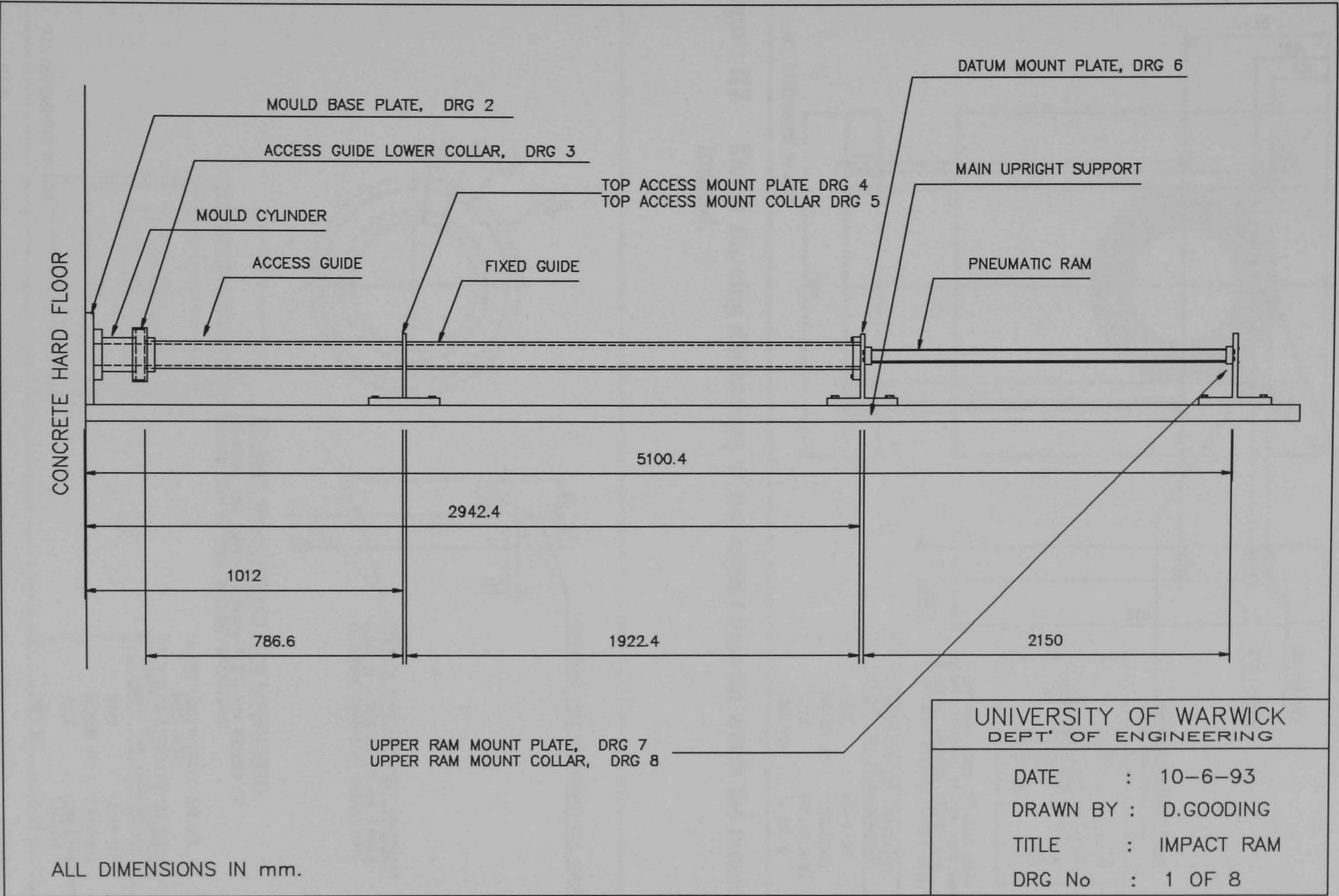

Figure K1 Assembly drawing of impact rig showing the pneumatic ram, guide tube, mounting points and base plate.

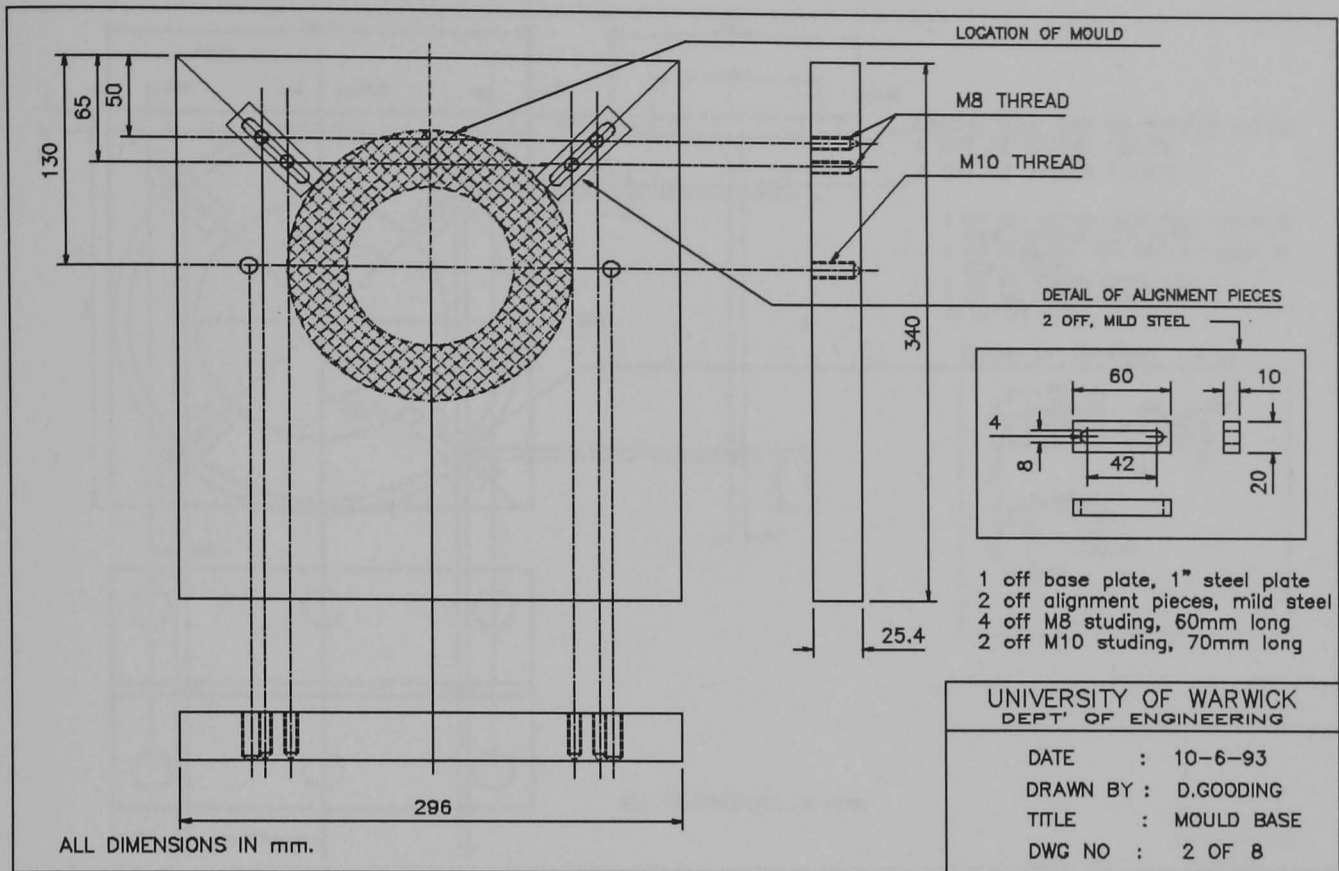

Figure K2 Detail showing dimensions of the impact base on which the mould is located.

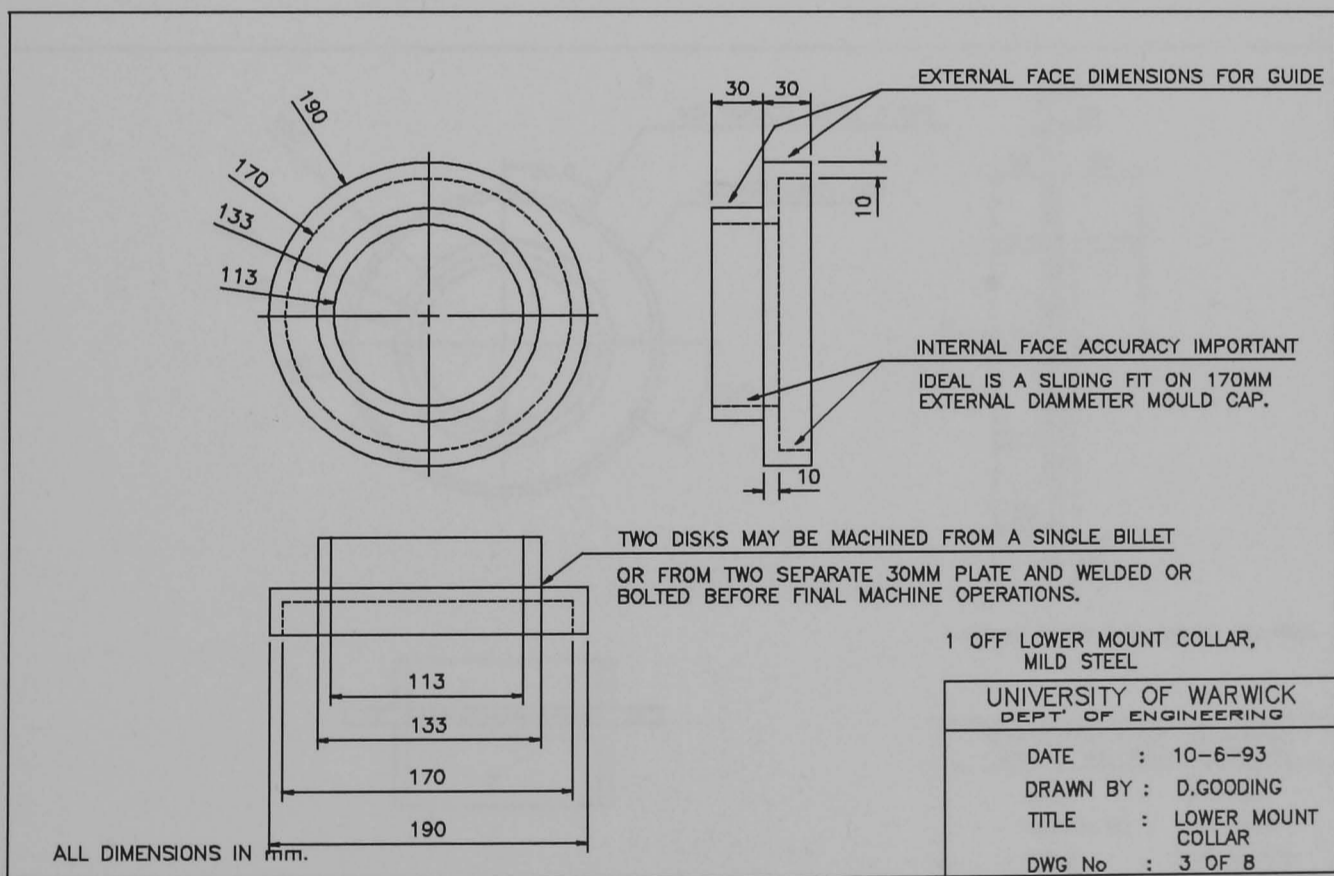

Figure K3 Detail showing dimensions of lower mount collar which couples the lower guide pipe with the impact mould

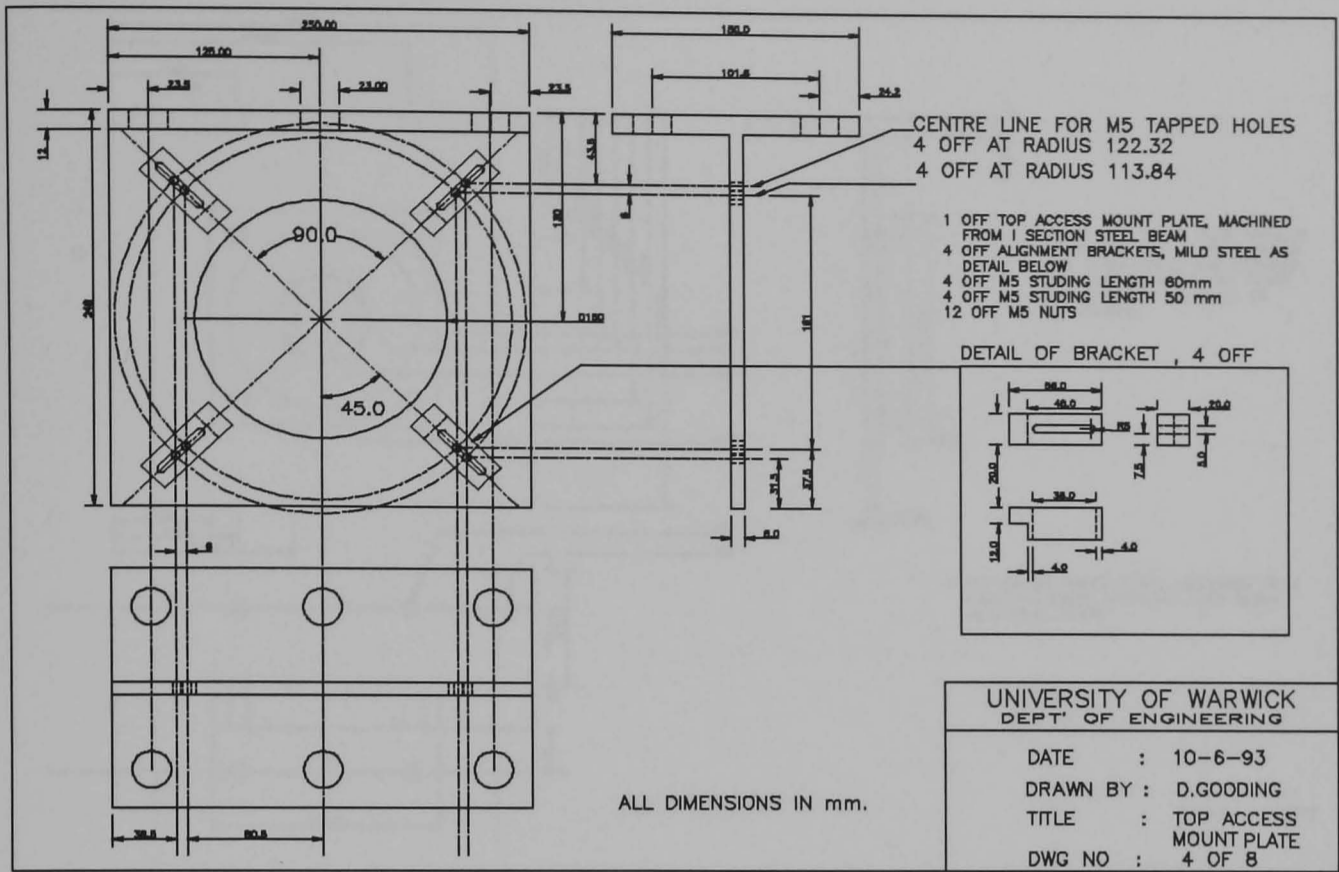

Figure K4 Detail showing dimensions of top access mounting plate

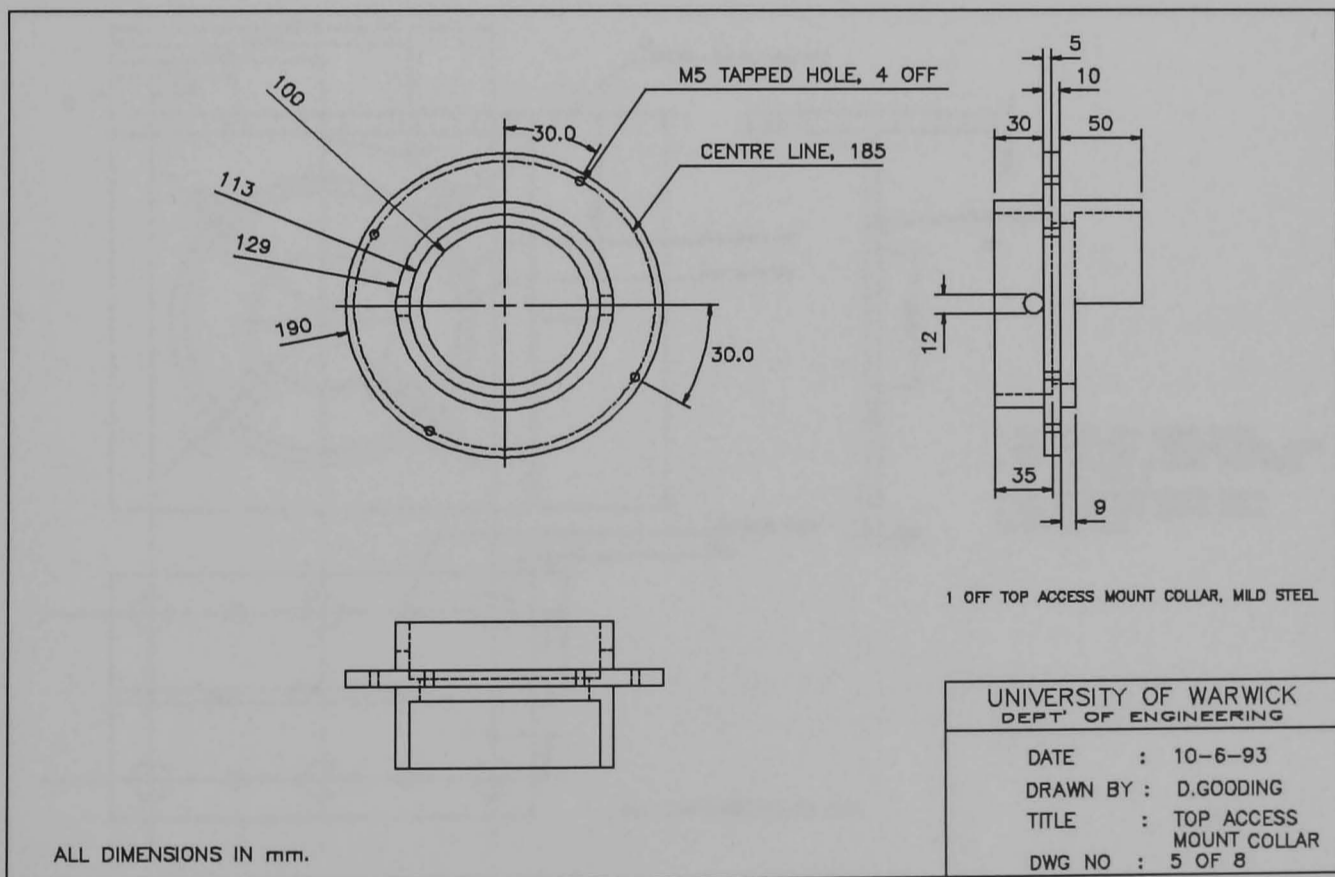

Figure K5 Detail showing dimensions of top access mounting collar

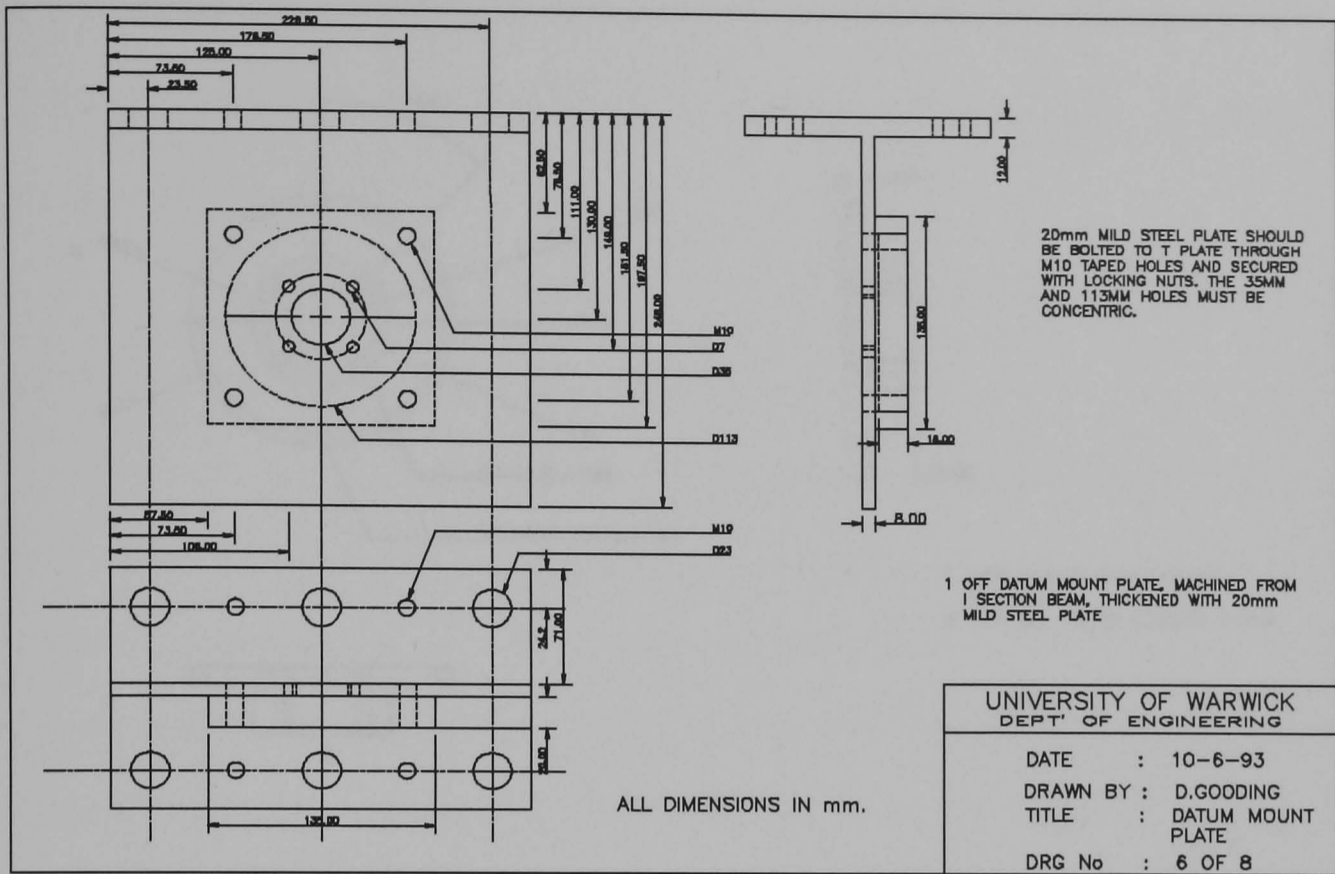

Figure K6 Detail showing dimensions of datum mounting plate

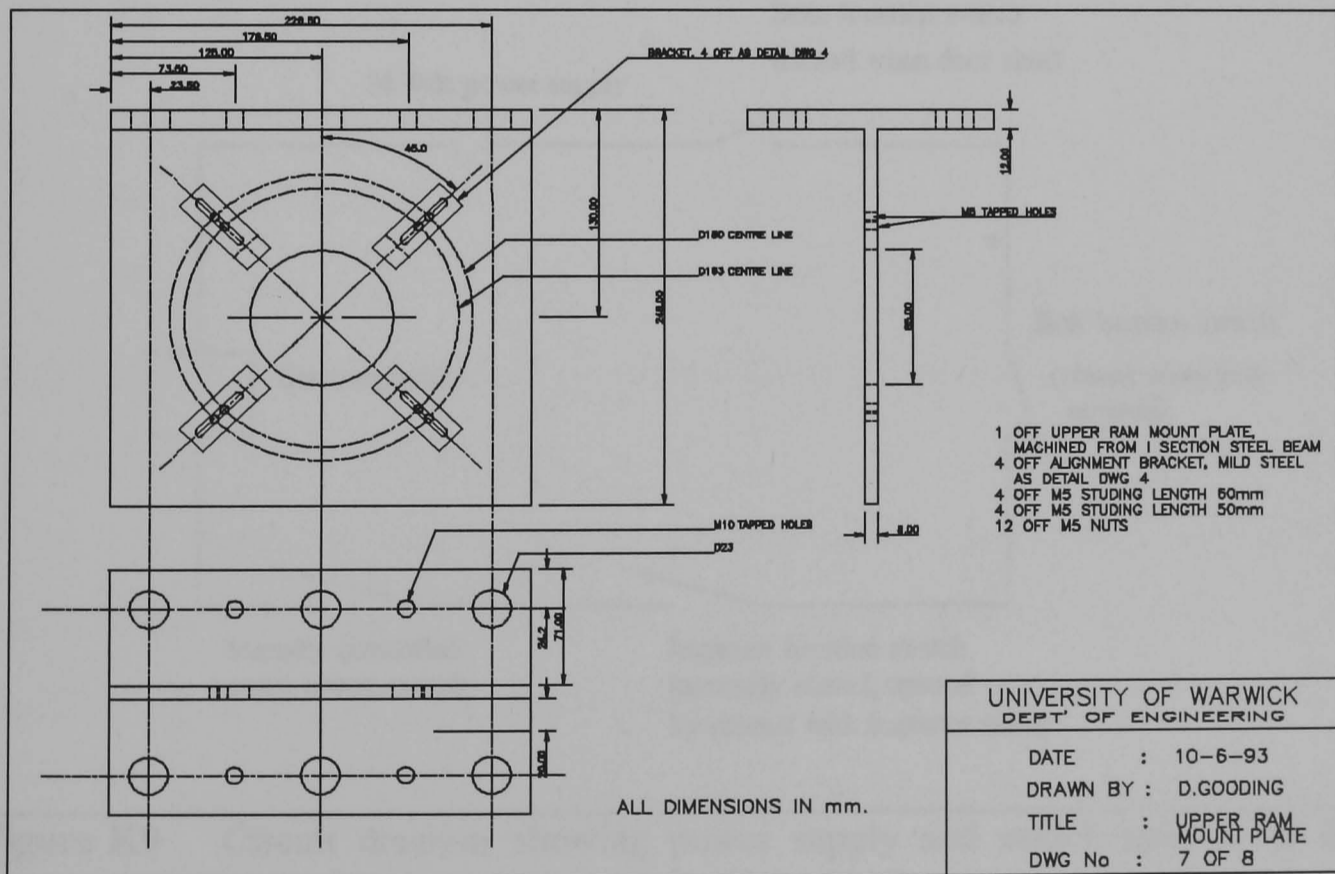

Figure K7 Detail showing dimensions of upper ram mounting plate

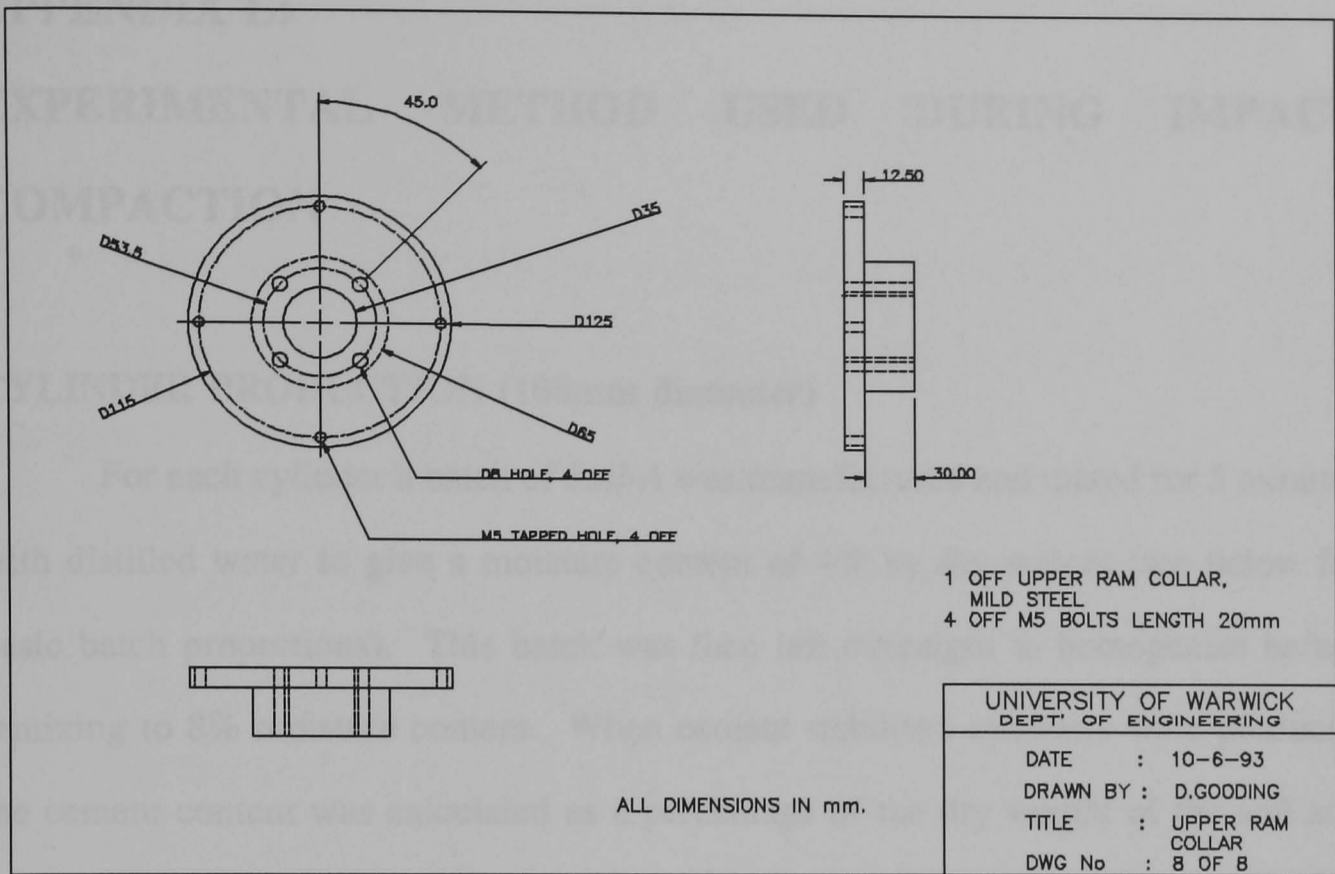

Figure K8 Detail showing dimensions of upper ram mounting collar

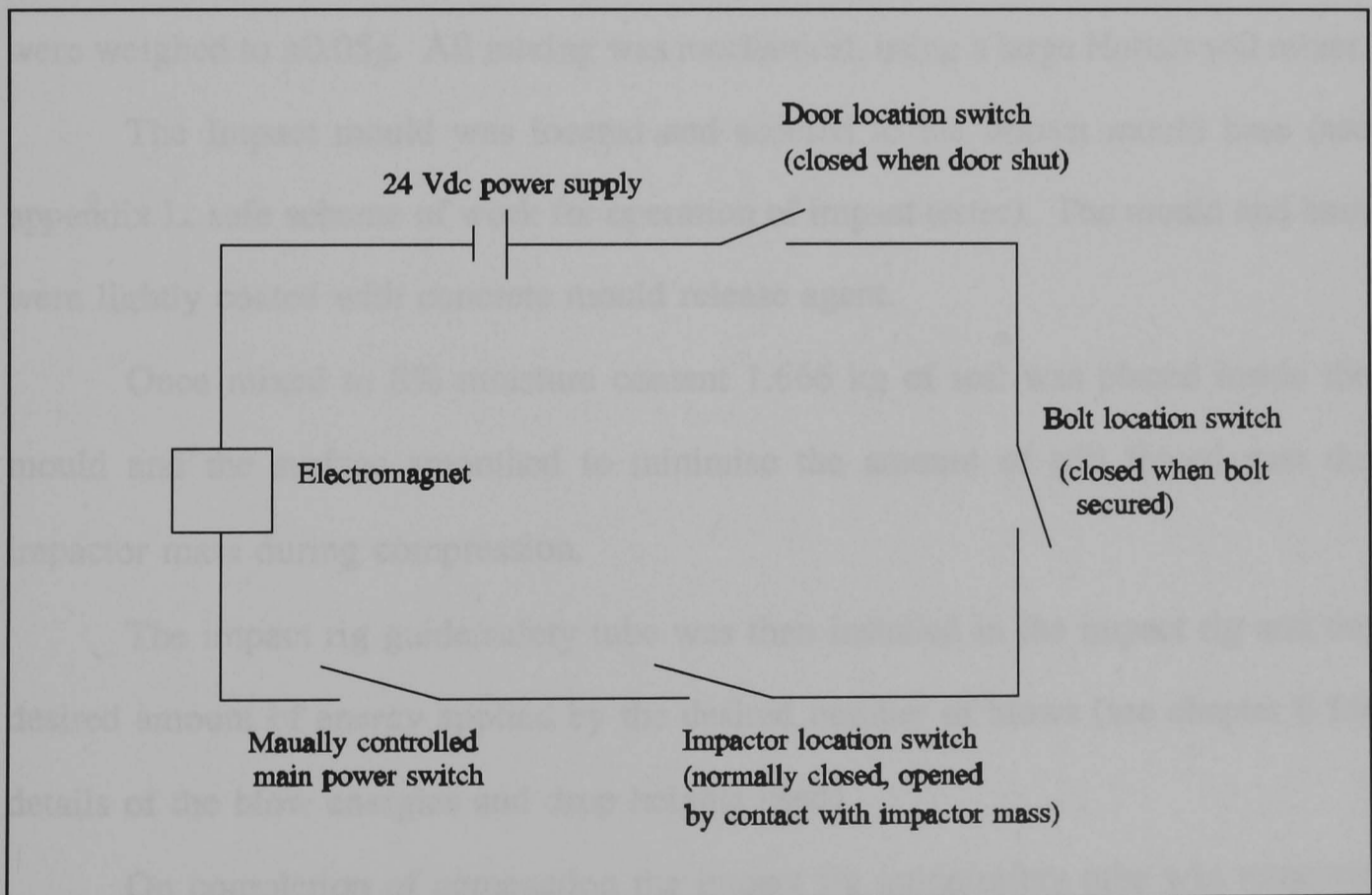

Figure K9 Circuit diagram showing power supply and switch system for the electromagnet

APPENDIX L:

EXPERIMENTAL METHOD USED DURING IMPACT COMPACTION

CYLINDER PRODUCTION (100mm diameter)

For each cylinder a batch of *Soil-A* was manufactured and mixed for 5 minutes with distilled water to give a moisture content of 4% by dry weight (see below for basic batch proportions). This batch was then left overnight to homogenise before remixing to 8% moisture content. When cement stabilised cylinders were produced the cement content was calculated as a percentage of the dry weight of the soil and added to the 4% homogenised batch. The cement batch was then mixed for a further 5 minutes before adding the remaining water and remixing. All batch proportions were weighed to $\pm 0.05\text{g}$. All mixing was mechanical, using a large Hobart soil mixer.

The Impact mould was located and secured to the impact mould base (see appendix L, safe scheme of work for operation of impact tester). The mould and base were lightly coated with concrete mould release agent.

Once mixed to 8% moisture content 1.666 kg of soil was placed inside the mould and the surface smoothed to minimise the amount of soil forced past the impactor mass during compression.

The impact rig guide/safety tube was then installed in the impact rig and the desired amount of energy applied by the desired number of blows (see chapter 6 for details of the blow energies and drop heights used).

On completion of compaction the impact rig guide/safety tube was removed and the mould removed from the base plate prior to cylinder ejection. The cylinder was ejected manually by inverting the mould and pushing it over one of the unused impact masses.

Once ejected the height of the cylinder was measured in at least four places using a set of vernier callipers. The weight of the cylinder was determined by weighing to the nearest 0.01g.

Cement stabilised cylinders were then placed inside a plastic bag containing a wet tissue and sealed before being left to cure for at least seven days. Unstabilised cylinders were left to dry out.

BASIC UNSTABILISED MIX PROPORTIONS

7.200kg builders sand (0.5% moisture content)

0.800kg kaoline grade E powder (0.7% moisture content)

0.277kg distilled water (for 4% homogenisation)

0.318kg distilled water (8% moisture content for compaction)

APPENDIX M:

NUMERICAL RESULTS FOUND DURING IMPACT COMPACTION

The experimental results for 100mm diameter cylinders impacted by a 23.35 kg impactor. Each sample received 464 J (279 J/kg)

Cylinder ID	No of blows	Impactor drop height /m	Ejected height /mm	Ejected mass /kg	Visible defects on ejection	Ejected bulk density /kg/m ³	Avg'ej' bulk density /kg/m ³
1.1.1	1	2.026	103.75	1.66182	flaws	2039	2031
1.1.2	1	2.026	104.10	1.66100	flaws	2032	
1.1.3	1	2.026	104.60	1.66230	flaws	2023	
1.2.1	2	1.013	103.40	1.65869	sml crks	2042	2044
1.2.2	2	1.013	103.65	1.65956	sml crks	2039	
1.2.3	2	1.013	103.00	1.65990	sml crks	2052	
1.4.1	4	0.506	102.30	1.65820	none	2064	2066
1.4.2	4	0.506	102.40	1.66049	none	2065	
1.4.3	4	0.506	101.90	1.65639	none	2070	
1.8.1	8	0.253	101.55	1.66419	none	2087	2085
1.8.2	8	0.253	101.50	1.66112	none	2084	
1.8.3	8	0.253	101.55	1.66288	none	2085	
1.16.1	16	0.127	101.20	1.66326	none	2093	2094
1.16.2	16	0.127	100.70	1.65990	none	2099	
1.16.3	16	0.127	101.20	1.66178	none	2091	
1.32.1	32	0.063	102.10	1.66336	none	2074	2084
1.32.2	32	0.063	101.00	1.65834	none	2091	
1.32.3	32	0.063	101.50	1.66283	none	2086	
1.64.1	64	0.032	103.70	1.65799	none	2036	2041
1.64.2	64	0.032	103.20	1.65505	none	2042	
1.64.3	64	0.032	103.10	1.65531	none	2044	

For cylinder ID key see overleaf

The experimental results for 100mm diameter cylinders impacted by a 35.00 kg impactor. Each sample received 464 J (279 J/kg)

Cylinder ID	No of blows	Impactor drop height /m	Ejected height /mm	Ejected mass /kg	Visible defects on ejection	Ejected bulk density /kg/m	Avg' ej' bulk density /kg/m
2.1.1	1	1.351	103.50	1.66060	med crks	2043	2041
2.1.2	1	1.351	103.65	1.66122	med crks	2041	
2.1.3	1	1.351	103.65	1.65933	med crks	2038	
2.2.1	2	0.676	103.00	1.66028	none	2052	2053
2.2.2	2	0.676	103.00	1.65956	none	2051	
2.2.3	2	0.676	102.85	1.66033	none	2055	
2.4.1	4	0.338	101.70	1.65973	none	2078	2080
2.4.2	4	0.338	101.70	1.66225	none	2081	
2.4.3	4	0.338	101.70	1.66295	none	2082	
2.8.1	8	0.169	101.25	1.66242	none	2091	2093
2.8.2	8	0.169	101.15	1.66248	none	2093	
2.8.3	8	0.169	101.05	1.66254	none	2095	
2.16.1	16	0.084	100.85	1.66242	none	2099	2099
2.16.2	16	0.084	100.80	1.66184	none	2099	
2.16.3	16	0.084	100.80	1.66184	none	2099	
2.32.1	32	0.042	100.95	1.66034	none	2094	2096
2.32.2	32	0.042	100.75	1.66068	none	2099	
2.32.3	32	0.042	100.95	1.66166	none	2096	

Cylinder Id: first number represents impactor mass used;
1 = 23.35 kg, 2 = 35.00 kg, 3 = 46.8 kg
Second number represents number of equal blows used to achieve a total of 464 J
Third number represents number of sample in its set of three; 1, 2 or 3

The experimental results for 100mm diameter cylinders impacted by a 46.80 kg impactor. Each sample received 464 J (279J/kg)

Cylinder ID	No of blows	Impactor drop height /m	Ejected height /mm	Ejected mass /kg	Visible defects on ejection	Ejected bulk density /kg/m	Avg' ej' bulk density /kg/m
3.1.1	1	1.011	103.10	1.66082	sml crks	2051	2049
3.1.2	1	1.011	103.15	1.65942	sml crks	2048	
3.1.3	1	1.011	102.90	1.65605	sml crks	2049	
3.2.1	2	0.505	101.95	1.66146	none	2075	2073
3.2.2	2	0.505	101.97	1.66009	none	2073	
3.2.3	2	0.505	102.00	1.65888	none	2071	
3.4.1	4	0.253	101.40	1.66314	none	2088	2088
3.4.2	4	0.253	101.40	1.66208	none	2087	
3.4.3	4	0.253	101.35	1.66238	none	2088	
3.8.1	8	0.126	101.05	1.66243	none	2095	2095
3.8.2	8	0.126	101.00	1.66137	none	2094	
3.8.3	8	0.126	100.90	1.66056	none	2095	
3.16.1	16	0.063	100.40	1.66018	none	2105	2103
3.16.2	16	0.063	100.60	1.66021	none	2101	
3.16.3	16	0.063	100.60	1.66205	none	2104	
3.32.1	32	0.032	100.75	1.65748	none	2095	2097
3.32.2	32	0.032	100.90	1.65867	none	2093	
3.32.3	32	0.032	100.50	1.66086	none	2104	
3.64.1	64	0.016	103.60	1.65360	none	2032	2030
3.64.2	64	0.016	103.70	1.65458	none	2032	
3.64.3	64	0.016	103.90	1.65300	none	2026	

APPENDIX N:

UNCOMPILED FORTRAN LISTING OF FINAL SIMULATION PROGRAM

It is again stressed that the computer program given here is not recommended for further use as it is highly dependent on the values used for the spring constants.

```
c      for spring compression < 0.54716mm assume it is a straight line
c      f(N)=849x(mm)+8.06
c      for x>0.54716 assume to a good approximation, with no points of
C      inflexion f(N)=2160.94x^6-5526.15x^5+4435.16x^4+291.967
c      kfu= constant k1, =894 for spring compression < 0.54716
c      kfu=(6*j1*x^5)-(5*j2*x^4)+(4*j3*x^3)
```

```
*****
*      define variables                      *
*****
```

```
REAL*8 T,DT,G,ELASTIC1,RELAX3,U2CUTOFF
REAL*8 NEGL4CO, CSEP
REAL*8 RELAX4,L3CUTOFF
REAL K1,J1,J2,J3,DTORG
INTEGER N,I,P,NUM,D,E
T = 0
DTORG = 0.000000005
DT=DTORG
G = 9.81
N = 0
I = 0
NUM=0
D=0
E=0
```

```

ELASTIC1 = 23.8887E6
C ELASTIC1 FOR 4 MPa CURVE = 65.93E6
C ELASTIC1 FOR 2 MPa CURVE = 23.8887E6
RELAX3 = 106.1538E6
C RELAX3 FOR 4 MPa CURVE = 226.229E6
C RELAX3 FOR 2MPa CURVE = 106.1538E6
C RELAX4 = 12.537E6
U2CUTOFF = 0.938
NEGL4CO = -0.01
K1=894
J1=2231.7
J2=5703.42
J3=4550.1

*****
* DEFINE ARRAYS *
*****

REAL*8 FD(0:20,-1:2), FU(0:20,-1:2), V(0:21,0:2)
REAL*8 A(0:20,1:2), X(0:21,1:2), M(0:20)
REAL*8 PF(0:20), FUMAXT(0:20), FUMAXP(0:20)
REAL*8 XUSEP(0:20), KFU(0:20,0:1), KFUMAX(0:20)
REAL*8 SFL(0:20), SEP(0:20), SL(0:20)
INTEGER FLAGFU(0:20)

*****
* OPEN EXTERNAL FILES CONTAINING ARRAY DATA *
*****

OPEN (UNIT=10, FILE='FD.DAT', STATUS='OLD')
OPEN (UNIT=11, FILE='FU.DAT', STATUS='OLD')
OPEN (UNIT=12, FILE='V.DAT', STATUS='OLD')
OPEN (UNIT=13, FILE='A.DAT', STATUS='OLD')
OPEN (UNIT=14, FILE='XF.DAT', STATUS='OLD')
OPEN (UNIT=15, FILE='M.DAT', STATUS='OLD')

```

```
*****
*   OPEN FILE FOR DATA TO BE STORED (SEQUENTIAL) *
*   EITHER ALL OP OR ALL PF FILES USED, NOT BOTH *
*****
```

```
C   OPEN (UNIT=16, FILE='OP02.DAT', STATUS='NEW')
C   OPEN (UNIT=17, FILE='OP35.DAT', STATUS='NEW')
C   OPEN (UNIT=18, FILE='OP68.DAT', STATUS='NEW')
C   OPEN (UNIT=19, FILE='OP911.DAT', STATUS='NEW')
C   OPEN (UNIT=20, FILE='OP1214.DAT', STATUS='NEW')
C   OPEN (UNIT=21, FILE='OP1517.DAT', STATUS='NEW')
C   OPEN (UNIT=22, FILE='OP1820.DAT', STATUS='NEW')
```

```
OPEN (UNIT=23, FILE='PF02.DAT', STATUS='NEW')
OPEN (UNIT=24, FILE='PF35.DAT', STATUS='NEW')
OPEN (UNIT=25, FILE='PF68.DAT', STATUS='NEW')
OPEN (UNIT=26, FILE='PF911.DAT', STATUS='NEW')
OPEN (UNIT=27, FILE='PF1214.DAT', STATUS='NEW')
OPEN (UNIT=28, FILE='PF1517.DAT', STATUS='NEW')
OPEN (UNIT=29, FILE='PF1820.DAT', STATUS='NEW')
OPEN (UNIT=30, FILE='PFLAG.DAT', STATUS='NEW')
```

```
*****
*   READ DATA FROM .DAT FILES INTO ARRAY           *
*   AND INITIALISE WORKING ARRAYS                   *
*****
```

```
READ (10,*) (FD(I,-1), FD(I,0), FD(I,1), FD(I,2), I=0, 20)
READ (11,*) (FU(I,-1), FU(I,0), FU(I,1), FU(I,2), I=0, 20)
READ (12,*) (V(I,0), V(I,1), V(I,2), I=0, 21)
READ (13,*) (A(I,1), A(I,2), I=0, 20)
READ (14,*) (X(I,1), X(I,2), I=0, 21)
READ (15,*) (M(I), I=0, 20)
```

```

*****
*   AS IMPACTOR MASS ALWAYS SUBJECT TO GRAVITATIONAL   *
*   ACCELERATION, ALWAYS SUBJECT TO DOWNWARD FORCE     *
*   =MASS*g                                             *
*****

```

```

FD(0,-1)=M(0)*G
FD(0,0)=M(0)*G
FD(0,1)=M(0)*G
FD(0,2)=M(0)*G

```

```

DO 2 D=0,20
  FUMAXT(D)=0
  FUMAXP(D)=0
  KFUMAX(D)=0
  KFU(D,0)=K1*1000
  KFU(D,1)=0
  FLAGFU(D)=1

```

```
2 CONTINUE
```

```

DO 3 E=0,20
  SFL(E)=10
  SL(E)=0
  SEP(E)=0

```

```
3 CONTINUE
```

```

*****
*           WRITE INITIAL DATA TO OUTPUT .DAT FILE   *
*****

```

```

C   WRITE (16,180) T, X(0,1), X(1,1), X(2,1)
C   WRITE (17,180) T, X(3,1), X(4,1), X(5,1)
C   WRITE (18,180) T, X(6,1), X(7,1), X(8,1)
C   WRITE (19,180) T, X(9,1), X(10,1), X(11,1)
C   WRITE (20,180) T, X(12,1), X(13,1), X(14,1)
C   WRITE (21,180) T, X(15,1), X(16,1), X(17,1)
C   WRITE (22,180) T, X(18,1), X(19,1), X(20,1)

```

5 FORMAT (E12.5,1X,I4)

6 FORMAT (I2,1X,E17.10,1X,I2,1X,E17.10)

```
*****
*      TIME OUT TEST FOR T                      *
*****
```

```
10 IF (T.GE.0.5) GOTO 1000
    N=0
```

```
*****
*      NEW DATA VALUES...COMPUTATION          *
*****
```

```
20 IF (N.LE.20) THEN
    IF (N.EQ.0) THEN
        FD(N,2)=FD(N,1)
    ENDIF
```

```
*****
*      NOTE TEMP AND PER MAX FOR FU AND POSITION IN      *
*      HYSTERESIS LOOP                                  *
*****
```

```
40  IF (FLAGFU(N).EQ.0) GOTO 80
    IF (FU(N,-1).LE.FU(N,0).AND.FU(N,0).LE.FU(N,1)) THEN
        IF (FU(N,1).GT.FUMAXT(N)) THEN
            FUMAXT(N)=FU(N,1)
            IF (FUMAXT(N).GT.FUMAXP(N)) THEN
                FUMAXP(N)=FUMAXT(N)
            ENDIF
        ENDIF
        GOTO 45
    ENDIF
    IF (FU(N,-1).LE.FU(N,0).AND.FU(N,0).GE.FU(N,1)) THEN
        FUMAXT(N)=FU(N,0)
        IF (FUMAXT(N).GT.FUMAXP(N)) THEN
```

```

        FUMAXP (N) =FUMAXT (N)
    ENDIF
GOTO 55
ENDIF
IF (FU (N, -1) .GE. FU (N, 0) .AND. FU (N, 0) .GE. FU (N, 1)) GOTO 55
IF (FU (N, -1) .GE. FU (N, 0) .AND. FU (N, 0) .LE. FU (N, 1)) GOTO 45
45 IF (FU (N, 1) .GE. (U2CUTOFF*FUMAXP (N) )) THEN
    SEP (N) = (X (N+1, 1) -X (N, 1) )
    SL (N) = (SFL (N) -SEP (N) )
    IF (SL (N) .LE. 0.547619) THEN
        KFU (N, 1) = (K1) *1000
C        *1000 to put kfu in N/M
        IF (KFUMAX (N) .LT. KFU (N, 1) ) THEN
            KFUMAX (N) =KFU (N, 1)
        ENDIF
        GOTO 80
    ELSE
        KFU (N, 1) =1000* ( (6*J1*SL (N) **5) - (5*J2*SL (N) **4) +
+        (4*J3*SL (N) **3) )
        IF (KFUMAX (N) .LT. KFU (N, 1) ) THEN
            KFUMAX (N) =KFU (N, 1)
        ENDIF
    ENDIF
    GOTO 80
ELSE
    KFU (N, 1) =ELASTIC1
    IF (KFUMAX (N) .LT. KFU (N, 1) ) THEN
        KFUMAX (N) =KFU (N, 1)
    ENDIF
    GOTO 80
ENDIF
55 IF (FU (N, 1) .GE. (NEGL4CO*FUMAXP (N) )) THEN
    KFU (N, 1) =RELAX3
    IF (KFUMAX (N) .LT. KFU (N, 1) ) THEN
        KFUMAX (N) =KFU (N, 1)
    ENDIF
ELSE

```

```

      KFU(N,1)=0
      FU(N,1)=0
      FD(N+1,1)=0
      XUSEP(N)=(X(N+1,1)-X(N,1))
      FLAGFU(N)=0
      WRITE (30,6) FLAGFU(N), T, N, XUSEP(N)
      PRINT *, 'SEGMENT ', N, ' DECOUPLED AT T= ', T
      GOTO 110
ENDIF

*****
*          TEST TO SEE IF FD/FU STILL DETACHED IF YES CONTINUE*
*          IF NO UPDATE FD/FU VALUES TO ELASTIC1 RANGE          *
*****

80    IF (FLAGFU(N).EQ.0) THEN
      IF (X(N+1,1)-X(N,1).LT.XUSEP(N)) THEN
        FLAGFU(N)=1
        PRINT *, 'SEGMENT ', N, ' GOOD AGAIN AT T= ', T
        CSEP=(X(N+1,1)-X(N,1))
        WRITE (30,6) FLAGFU(N), T, N, CSEP
        FU(N,2)=ELASTIC1*((SFL(N)-(X(N+1,1)-X(N,1)))/1000)
C     NOTE DIVIDED BY 1000 TO CONVERT X(*,*) POSITION DATA
C     FROM MM TO M AS REQUIRED FOR SPRING CONSTANTS
        IF (FU(N,2).GE.U2CUTOFF*FUMAXP(N)) THEN
          DX=((U2CUTOFF*FUMAXP(N))/ELASTIC1)*1000
C     *1000 TO CONVERT DX FROM M TO MM
          DX2=(X(N+1,1)-X(N,1))
C     NOTE DX2 ALREADY IN MM
          SL(N)=(SFL(N)-DX2)
          IF (SL(N).LE.0.547619) THEN
            KFU(N,1)=(K1)*1000
C     NOTE *1000 TO CONVERT KFU FROM N/MM TO N/M
            IF (KFUMAX(N).LT.KFU(N,1)) THEN
              KFUMAX(N)=KFU(N,1)
            ENDIF
          ENDIF
        ENDIF
      ENDIF

```

```

          FU(N,2) = (U2CUTOFF*FUMAXP(N)) + (KFU(N,1) *
+          ((SFL(N)-DX-DX2)/1000))
          FD(N+1,2) = FU(N,2)
          GOTO 150
        ELSE
          KFU(N,1) = 1000 * ((6*J1*SL(N)**5) - (5*J2*SL(N)**4) +
+          (4*J3*SL(N)**3))
C          NOTE *1000 TO CONVERT KFU FROM N/MM TO N/M
          IF (KFUMAX(N) .LT. KFU(N,1)) THEN
            KFUMAX(N) = KFU(N,1)
          ENDIF
          FU(N,2) = (U2CUTOFF*FUMAXP(N)) + (KFU(N,1) *
+          ((SFL(N)-DX-DX2)/1000))
          FD(N+1,2) = FU(N,2)
          GOTO 150
        ENDIF
      ENDIF
    ENDIF
    FD(N+1,2) = FU(N,2)
    KFU(N,1) = ELASTIC1
    XUSEP(N) = 0
    GOTO 150
  ENDIF
ENDIF
110 IF (N.EQ.20) THEN
      FU(N,2) = FU(N,1) + (((KFU(N,1)-KFU(N,0))/2) + KFU(N,1))
+      *DT*0.5 * ((3*V(N,1)) - V(N,0))
      GOTO 150
    ENDIF
140 FU(N,2) = FU(N,1) + (((KFU(N,1)-KFU(N,0))/2) + KFU(N,1))
+      *DT*0.5 * (((3*V(N,1)) - V(N,0)) - (3*V(N+1,1))
+      - V(N+1,0)))
      FD(N+1,2) = FU(N,2)
150 A(N,2) = G + ((FD(N,2) - FU(N,2))/M(N))
      V(N,2) = V(N,1) + (DT*0.5*(A(N,2) + A(N,1)))
      X(N,2) = X(N,1) + (DT*500*(V(N,2) + V(N,1)))
160 PF(N) = ((FD(N,2) + FU(N,2))/2) / (7.85398E-3)
      N=N+1

```

```
GOTO 20
ENDIF
```

```
*****
*      INITIAL VALUES OF PF AT TIME = 0      *
*****
```

```
IF (T.EQ.0) THEN
  WRITE (23,180) T, PF(0), PF(1), PF(2)
  WRITE (24,180) T, PF(3), PF(4), PF(5)
  WRITE (25,180) T, PF(6), PF(7), PF(8)
  WRITE (26,180) T, PF(9), PF(10), PF(11)
  WRITE (27,180) T, PF(12), PF(13), PF(14)
  WRITE (28,180) T, PF(15), PF(16), PF(17)
  WRITE (29,180) T, PF(18), PF(19), PF(20)
ENDIF
```

```
*****
*      VALUES OF X RECORDED IN A SEQUENTIAL FILE      *
*****
```

```
IF (NUM.EQ.400) THEN
  PRINT 5, T
C   WRITE (16,180) T, X(0,2), X(1,2), X(2,2)
C   WRITE (17,180) T, X(3,2), X(4,2), X(5,2)
C   WRITE (18,180) T, X(6,2), X(7,2), X(8,2)
C   WRITE (19,180) T, X(9,2), X(10,2), X(11,2)
C   WRITE (20,180) T, X(12,2), X(13,2), X(14,2)
C   WRITE (21,180) T, X(15,2), X(16,2), X(17,2)
C   WRITE (22,180) T, X(18,2), X(19,2), X(20,2)

  WRITE (23,180) T, PF(0), PF(1), PF(2)
  WRITE (24,180) T, PF(3), PF(4), PF(5)
  WRITE (25,180) T, PF(6), PF(7), PF(8)
  WRITE (26,180) T, PF(9), PF(10), PF(11)
  WRITE (27,180) T, PF(12), PF(13), PF(14)
  WRITE (28,180) T, PF(15), PF(16), PF(17)
```

```

        WRITE (29,180) T, PF(18), PF(19), PF(20)
170    FORMAT (E17.10,1X,I1,5(1X,E17.10))
180    FORMAT (E17.10,1X,3(E17.10,1X))
        NUM=0
    ENDIF

```

```

*****
*      INCREMENT TOTAL RUN TIME (T) BY STEP (DT)      *
*****

```

```

        T=T+DT
        NUM=NUM+1

```

```

*****
*      UPDATE ARRAY VALUES                          *
*****

```

```

        P=0
190    IF (P.LE.20) THEN
            FD(P,-1)=FD(P,0)
            FD(P,0)=FD(P,1)
            FD(P,1)=FD(P,2)
            FD(P,2)=0
            FU(P,-1)=FU(P,0)
            FU(P,0)=FU(P,1)
            FU(P,1)=FU(P,2)
            FU(P,2)=0
            V(P,0)=V(P,1)
            V(P,1)=V(P,2)
            V(P,2)=0
            A(P,1)=A(P,2)
            A(P,2)=0
            X(P,1)=X(P,2)
            X(P,2)=0
            PF(P)=0
            KFU(P,0)=KFU(P,1)
            KFU(P,1)=0

```

```
        P=P+1
        GOTO 190
    ENDIF
    GOTO 10
1000  END
```