



European Coordination for Accelerator Research and Development

## PUBLICATION

# Distributed Radiation Monitoring System for Linear Accelerators based on CAN Bus

Kozak, T (Technical University of Lodz) *et al*

04 February 2010

The research leading to these results has received funding from the European Commission under the FP7 Research Infrastructures project EuCARD, grant agreement no. 227579.

This work is part of EuCARD Work Package **10: SC RF technology for higher intensity proton accelerators and higher energy electron linacs.**

The electronic version of this EuCARD Publication is available via the EuCARD web site <<http://cern.ch/eucard>> or on the CERN Document Server at the following URL : <<http://cdsweb.cern.ch/record/1237831>>

# Distributed Radiation Monitoring System for Linear Accelerators based on CAN Bus

Tomasz Kozak, Dariusz Makowski, Andrzej Napieralski  
Department of Microelectronics and Computer Science  
Technical University of Lodz  
Lodz, Poland

**Abstract**—Gamma and neutron radiation is produced during the normal operation of linear accelerators like Free-Electron Laser in Hamburg (FLASH) or X-ray Free Electron Laser (X-FEL). Gamma radiation cause general degeneration of electronics devices and neutron fluence can be a reason of soft error in memories and microcontrollers. X-FEL accelerator will be built only in one tunnel, therefore most of electronic control systems will be placed in radiation environment. Exposing control systems to radiation may lead to many errors and unexpected failure of the whole accelerator system. Thus, the radiation monitoring system able to monitor radiation doses produced near controlling systems is crucial. Knowledge of produced radiation doses allows to detect errors caused by radiation, make plans of essential exchange of control systems and prevent accelerator from serious damages. The paper presents the project of radiation monitoring system able to monitor radiation environment in real time.

**Index Terms**—Controller Area Network, gamma radiation dosimetry, neutron radiation dosimetry, Radiation sensing Field-Effect Transistor, linear accelerator, X-ray Free Electron Laser

## I. INTRODUCTION

During normal operation of high-energy accelerator like FLASH or X-FEL, the gamma and neutron radiation is produced as a side effect. Great majority of electronic devices and system is sensitive to this kind of radiation. Therefore, many researches has been made to estimate radiation destructive influence [1]. The results show that the gamma radiation is responsible for general degradation of electric parameters of devices. As an example in MOS transistors threshold voltage, transconductance, leakage current or drain-source breakdown voltage are affected. The neutron fluence is a reason of Single Effects Events (SEE) in memories, microcontrollers and others devices. The SEE can be divided into two groups: destructive effects, which cause permanent device damage and non-destructive effects, which are reversible. To the first group can include e.g. Single Event Latch-Up (SEL), Single Event Snapback (SEB) or Single Event Burnout (SEB). The other one is represented by Single Event Upset (SEU), Single Event Transient (SET) or Single Event Functional Interrupt (SEFI) [2, 3]. All mentioned factors cause the best solution during designing linear accelerators is building two parallel tunnels and place main beam pipe and control systems in separated tunnels. Unfortunately it dramatically increases costs of project. Therefore the newest project carried out at DESY research centre - X-FEL will be built in only one tunnel [4, 5]. Thus all

electronic control systems and devices will be exposed to high-energy radiation and that is why radiation monitoring system able to measure doses absorbed by electronic devices is crucial. The system should be able to monitor radiation environment in real time and store measured data for further analysis.

## II. RADIATION MONITORING SYSTEM

The radiation monitoring system must be able to monitor gamma and neutron radiation doses in real time in crucial parts of the accelerator tunnel. General block diagram of the system is shown in Fig. 1.

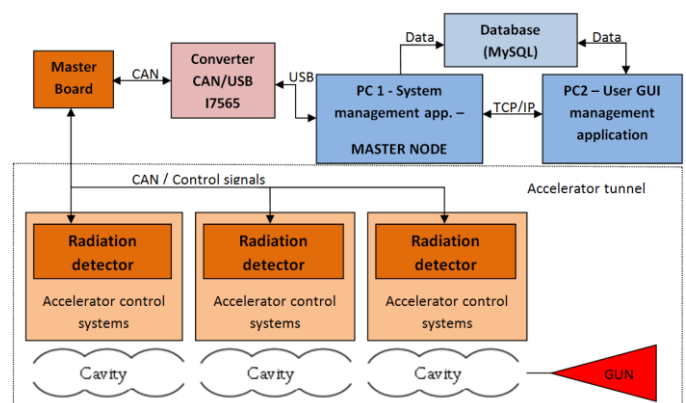

Figure 1. Block diagram of Radiation Monitoring System based on CAN

It is a distributed system, which consists of three main modules:

- 1) active radiation detectors
- 2) management application
- 3) user GUI application

All components will be briefly described in next parts of the paper. The detectors are prepared to be placed near all crucial accelerator controlling systems. Both applications are created to work on PC computer which must be placed in safe, non-radiation area. Management application and GUI use TCP/IP protocol to communicate between each other and connect to database. Therefore GUI software and database can run on independent computers, but placed in the same network as the Management application. Master Board node, whose main task is generating controlling signals essential to proceed hard reset of detectors, is also placed in the system. The system is designed to work with a maximum number of 60 detectors, which will be placed on distance of few hundreds meters in

whole accelerator tunnel. Old version of radiation monitoring system based on RS232 interface, called RadMon, has been designed and installed in FLASH accelerator, which is a research facility created to develop technologies necessary for X-FEL [4]. RadMon was used to develop and test radiation measurement methods, which are also used in described system [1]. X-FEL will be around 8 times bigger than FLASH, therefore new system capable to operate on bigger distances with high reliability is essential. A few communication interfaces have been considered to be used. Communication standard for distributed radiation monitoring system must provide at least three main features: reliability, immunity to radiation and electromagnetic disturbance (EMI) and possibility to communicate at distances over 1 kilometre. Fast transmission rate is not critical demand, because used bandwidth will be quite low (<10kb/s). All the above requirements are fulfilled by CAN (Controller Area Network) standard.

### A. Controller Area Network

The CAN standard was designed for automotive application in the late 80's, but it can be successfully used in other areas. Main goal of creating this protocol was receiving fast, flexible, immune, reliable and safe communication interface. Basic features of CAN are:

- 1) Fast transmission speeds (up to 1 Mb/s) and long distances (up to 10 kilometres)
- 2) Differential transmission of data which provide immunity to EM disturbances
- 3) Broadcast transmission in multi-master system
- 4) Message oriented protocol
- 5) Effective data correctness and delivery mechanisms
- 6) Simple 2-wire bus

Theoretically there is no limit in the amount of nodes, but in practice this number is limited by CAN bus capacity to approximately 120. Maximum speed of data transmission depends on bus length as it is shown in Fig. 2.

Distance [m]	Maximum data rate [kb/s]
40	1000
100	500
200	200
500	100
1000	50
10000	5

Figure 2. CAN bus speeds in bus length function

CAN uses a differential transmission to achieve immunity to EMI disturbances. There are two states of the bus – dominant (logical false - 0) and recessive (logical true - 1). The dominant state has higher priority than recessive. When two devices transmit a different bit (0 and 1) in the same time the device, which transmit logical 0 receives the bus and second device will wait until bus will be free. This property is used in arbitration mechanism [7]. The priority of frame is determined by its ID field (see Fig. 4). The lower ID, the higher priority. The arbitration process is visualized on Fig. 3.

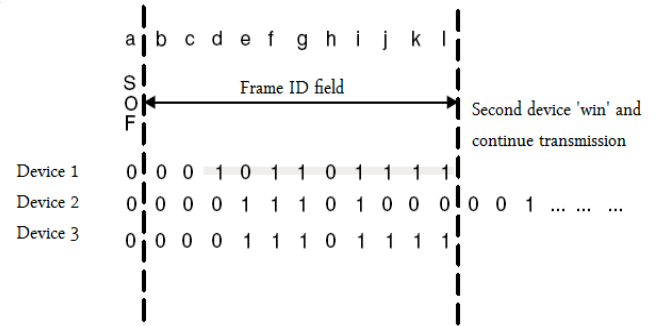

Figure 3. Arbitration process between three CAN nodes

A CAN network can be configured to support two subtypes of standard - CAN2.0A (base frame format) or CAN2.0B (extended frame format). The only difference between the two format is that CAN2.0B utilize 29-bit length frame identifier and CAN2.0A supports only 11-bit identifiers what allows to use 2040 (the seven most significant bits (ID-10 - ID-4) must not be all 'recessive') messages in system, what could be not enough in complex applications. In presented radiation monitoring system CAN2.0A is used. There are four frames type defined in CAN standard [6].

- 1) Data frame – frame contains node data
- 2) Remote frame – request for transmission of data frame with specified identifier field
- 3) Error frame – frame transmitted when any node detects a bus error
- 4) Overload frame – used to provide extra delay for data processing between data or remote frames

Structure of CAN2.0A data frame is presented below.

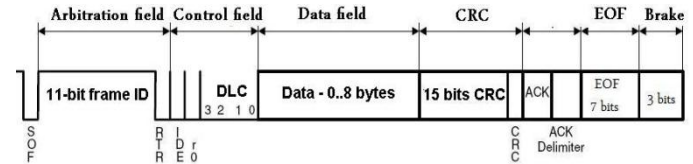

Figure 4. CAN standard data frame

Start Of Frame (SOF) and End Of Frame (EOF) are markers of begin and end of frame. RTR (Remote Transmission Request) bit determines if it is data or remote frame. IDE (Identifier Extension) bit is used only in CAN2.0B frames and it is always dominant in standard frames. DLC (Data Length Code) field specifies the amount of data, which will be transmitted in the frame. CRC (Cyclic Redundancy Check), which is added to every data frame is one of mechanisms of data transmission validity. CRC and ACK delimiters, EOF have fixed form and are used to check frame format correctness. In CAN interface method of bit stuffing is used to code non-fixed part of frame (arbitration, control, data and CRC fields). Bit stuffing automatically inserts a complementary bit in the actual transmitted bit stream whenever a transmitter detects five consecutive bits of identical value in the bit stream. It is essential because the whole bit stream is coded in the Non-Return-to-Zero (NRZ) format and without bit stuffing transmission synchronization could be lost. CAN protocol defines five types of errors,

which are automatically handled by CAN controllers. These errors are:

- 1) Bit error – every node during bit sending simultaneously monitors state of bus. If detected value is different from sent one an error is reported.
- 2) Stuff error – error occur when 6<sup>th</sup> consecutive equal bit levels are detected in fields, which are coded with stuffing method.
- 3) CRC error – error is reported, when CRC calculated by receiver is different than CRC received .
- 4) Form error – occurs when a fixed-form bit field contains one or more illegal bits.
- 5) Acknowledgement error – error detected by a transmitter whenever it does not monitor a ‘dominant’ bit during ACK slot.

CAN standard contains effective methods of error correcting, which cause that residual error probability for undetected corrupted messages is equal to message speed rate multiply by  $4.7 \cdot 10^{-11}$  [6]. All this features cause that CAN bus deemed to be a very good solution to be used in radiation monitoring system, which first of all must be able to reliably work for extended periods of time in hard environmental conditions.

### B. Active radiation detector

To perform measurement of radiation doses a dedicated detector, whose block diagram is show in Fig. 5, has been designed.

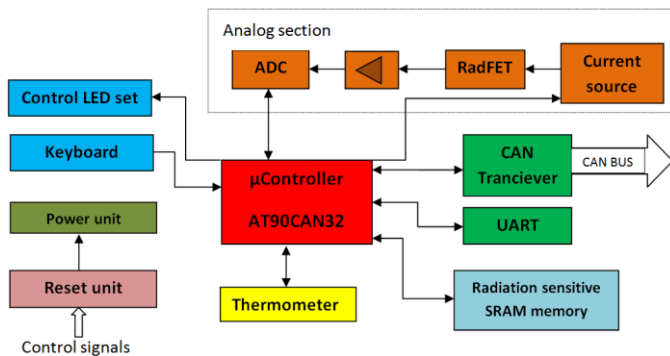

Figure 5. Block diagram of radiation detector

The detector is based on AVR core microcontroller AT90CAN32 produced by Atmel. The main reason of choosing this device was its built in CAN controller, which facilitates implementation of communication in the system. It has 32 kB of reprogrammable FLASH memory that is much more immune to radiation than e.g. SRAM and is utilized to store program and data. Sensor is active which means that after measurement it automatically initiates data transmission to the Master Node. RadFET and SRAM memory are used as a radiation dosimeters [1]. The RadFET dosimeter is a PMOS based sensor susceptible mainly to gamma radiation, which can be easily used in a digital readouts systems to supply real time absorbed doses measurements. The reader circuit configuration is shown below.

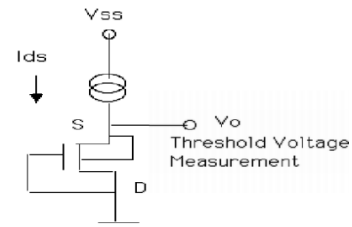

Figure 6. RadFET reader circuit configuration

The value of  $I_{ds}$  current is constant, therefore the threshold voltage is determined by transistor parameters, which are affected by radiation. Voltage shift can be easily converted to absorbed gamma dose. The sensitivity of dosimeter is a function of silicon oxide thickness and can be adjusted according to the requirements. The neutron fluence gauge is based on special sensitive SRAM where SEUs occur when memory is exposed to radiation. The controller constantly scans the SRAM to detect all SEUs, which are counted. Amount of SEU is directly proportional to absorbed dose of neutron fluence. A Samsung K6T4008 512kB memory has high radiation sensitivity what was experimentally proved and that is why it is utilized in the project [1]. The last value measured by sensor is current temperature in the tunnel, which is essential to compensate the RadFET voltage value, which depends on temperature. Important part of the detector is reset unit. During normal operation in radiation environment detector's software can stuck or be corrupted due to errors caused by radiation. Therefore special hard reset mechanism is provided. If system management application detects incorrect work of any detector it sends special command to Master Board, which via control signals activates reset unit of broken sensor. The unit proceeds hard reset by temporary power cut off and if corruption is not critical the normal work of detector should be restored. As one can notice the detector is based on low cost, easy accessible elements. Hence, even if the device is permanently damage its replacement is easy and cheap.

### C. System management application

The system management application is custom-made software written in C++ programming language prepared to run under Linux OS. It performs the role of Master Node in the system and is responsible for:

- 1) Receiving and interpreting data from radiation detectors.
- 2) Sending measurement data to prepared MySQL database.
- 3) Monitor status of sensors and in case of malfunction hard resetting.
- 4) Providing TCP/IP server responsible for communication with the system user.

Software uses multithread mechanism to provide reliability and fast answers on user demands - see Fig. 7. The main thread is responsible for analyzing CAN frames, sending measurement data to database, checking status of sensors and proceed with the hard reset routine if necessary. It is not obstructed by checking CAN bus status, because separated thread is responsible for receiving CAN frames, what guarantees no frames will be passed over and ignored. The TCP/IP server provides interface for system communication with 'external world'.

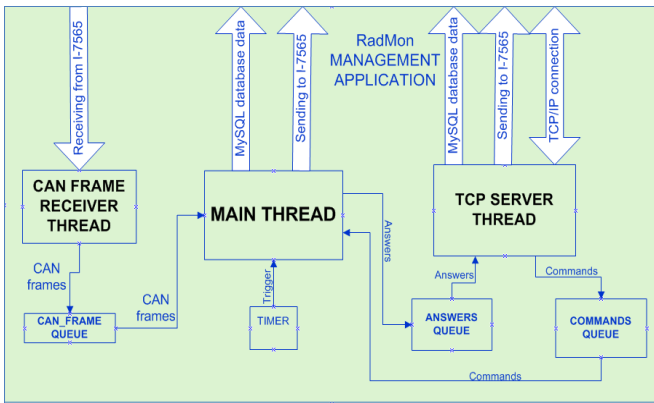

Figure 7. Block diagram of Management Application

It interprets set of commands used to controlling system status and behaviour. Server can handle only one client at the same time because only one user should have access to all systems' settings, otherwise decision conflicts can occur. The radiation monitoring system is also equipped in logging mechanism, which puts logs about important system's events like sensor status changes or execution of user's commands in database. The measurement data and logs are accessible thanks to GUI application.

#### D. System GUI application

The GUI application is used for visualisation of measured radiation doses, status of detectors and other data. The second function is providing access to system settings and log viewing. Software uses TCP/IP connection to communicate with the Management application and database (see Fig. 1). The GUI provide three main services:

- 1) Real time doses monitoring – Doses are calculated with resolution of 1 hour according to the newest measurement data from database. The functionality is accessible via Diagnostic panel.
- 2) Visualization of historical measurement – User can create charts with all kinds of measured values (radiation doses, RadFET voltage, temperature) with minimum 1 day resolution. Function accessible via ReadOut Panel.
- 3) Management and service of the System – User can start/stop/reset selected sensor. The acquiring of current RadFET's voltage and temperature is also possible. System logs viewer is also available via the same Service Panel

The GUI contains set of LEDs used to visualize status of all detectors, master boards and server and database connection. The GUI software utilizes QT libraries. QT is cross platform framework available on GNU GPL. Software was developed to be use under Linux OS, but it is easily to receive Windows or Mac OS versions. The release version of GUI application is provided with set of all essential QT libraries and short bash script. Therefore user can use this software even if QT is not installed on the computer.

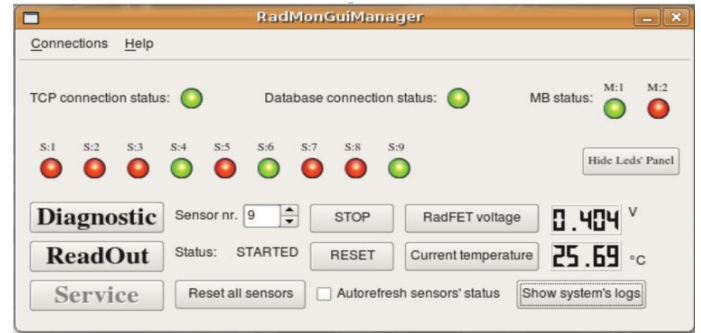

Figure 8. Service panel of GUI Application

### III. RESULTS

The new version of RadMon system based on CAN communication bus has been designed and built. Three exemplary detector nodes has been delivered for tests. Software generated measurement values (except temperature) were used to test the stability of all application and detector software due to not accessible radiation source. System was under test for 170 hours and during this period no errors were observed. Communication within the system run correctly and all data has been stored in MySQL database. Database and the Management Application was running on one PC and the GUI application was connected to the RadMon TCP Server Radiation via Internet. The software of some detectors was intentionally corrupted to check hard reset mechanism. All stacked sensors was reset by System Management Application.

### IV. CONCLUSIONS

The system was tested in laboratory conditions. Measurement methods used by radiation detector (RadFET and SRAM memories) has been tested in the past and its usability has been proved [1]. Thus, system after calibration should perform well in target environment, but final acceptance tests are still essential.

### ACKNOWLEDGMENT

The research leading to these results has received funding from the European Commission under the EuCARD FP7 Research Infrastructures grant agreement no. 227579. The author is a scholarship holder of project entitled "Innovative education ..." supported by European Social Fund.

### REFERENCES

- [1] D. Makowski, "The impact of Radiation on Electronic Devices with the special consideration of Neutron and Gamma Radiation Monitoring", PhD Thesis 2007.
- [2] G. Barbottin and A. Vapaille. Instabilities in Silicon Devices, New Insulators, devices and Radiation Effects. Elsevier, 1999.
- [3] F. Giustino, "Radiation Effects on Semiconductor Devices", PhD thesis, Politecnico di Totino, March 2001.
- [4] R. Brinkmann, "Accelerator Layout of the XFEL", *XXII International Linear Accelerator Conference*, vol. 1, pp. 2–7, August 2004.
- [5] A. Schwarz, "The European X-Ray free electron laser project at DESY", *Proceedings of the 2004 FEL Conference*, pp. 85-89, 2004
- [6] CAN Specification Version 2.0, Robert Bosch GmbH, 1991.
- [7] Pat Richards, CAN Physical Layer Discussion, Microchip Technology