

Error-Free 10.7 Gb/s Digital Transmission over 2 km Optical Link Using an Ultra-Low-Voltage Electro-Optic Modulator

D. Janner^a, M. Belmonte^b, M. Meschini^c, G. Parrini^d, G. Nunzi Conti^e, S. Pelli^e, V. Pruneri^{a,f}

^aICFO-Institut de Ciències Fotoniques, Mediterranean Technology Park, 08860 Castelldefels (Barcelona), Spain

^bOclaro Inc., Via F. Fellini, 4, I-20097 San Donato Milanese-Italy

^cIstituto Nazionale di Fisica Nucleare, Sezione di Firenze, via G. Sansone 1, I-50019 Sesto Fiorentino (FI) Italy

^dPhys. Dep. of the University and INFN Firenze, Via G. Sansone 1, I-50019 Sesto Fiorentino (FI) Italy

^eCNR-IFAC - Istituto di Fisica Applicata "Nello Carrara", via Madonna del Piano 10, I-50019 Sesto Fiorentino (FI) Italy

^fICREA - Institució Catalana de Recerca i Estudis Avançats, 08010 Barcelona, Spain

meschini@fi.infn.it

Abstract

We demonstrate the feasibility of 10.7 Gb/s error-free (BER < 10^{-12}) optical transmission on distances up to 2 km using a recently developed ultra-low-voltage commercial Electro-Optic Modulator (EOM) that is driven by 0.6 V_{pp} and with an optical input power of 1 mW. Given this low voltage operation, the modulator could be driven directly from the detectors' board signals without the need of any further amplification reducing significantly the power dissipation and the material budget.

I. INTRODUCTION

The Large Hadron Collider (located at CERN, Geneva, CH) is foreseen to be upgraded in the future to reach an ultimate peak luminosity of $10^{35} \text{ cm}^{-2} \text{ s}^{-1}$: that will be the so-called Super-LHC stage. In the SLHC scenario, the bandwidth needed for data extraction from tracking detectors will grow significantly due to the huge particle content at high repetition rates. Increase in bandwidth of the optical link is a key factor to allow fast data processing and to reduce latency times. Actual trend is focused on the development of 5 Gb/s devices (10 Gb/s in perspective) as elements of the total link architecture. However a further increase in the transmission rate could be necessary either to reduce the number of optical links per detector, leading to volume and cost reduction, or to fulfil the higher rate requested from possible new trigger schemes. Voltage driving and power consumption are strategic features of the data link in order to keep low the required power budget. EOMs allow using CW lasers as optical source sitting outside the harsh radiation environment, with positive impact on the reliability of the system and on the detector global required power budget.

II. LINK CONCEPT AND MEASUREMENTS

A. Electro Optic Modulators

Electro-Optic Modulators are widely employed in the telecom industry and represent a standard for 10 to 40Gb/s transmissions. Recent developments on modulators aiming at

low voltage operations are reported in [1], [2]. EOMs used in the measurements subject of the present work are off-the-shelf Lithium Niobate (LN) Mach-Zehnder modulators, with an electro-optic bandwidth (-3 dB) of 12.5 GHz and 10.7Gb/s transmission rate. They have been fabricated by Avanex (now Oclaro) company. The LN modulators have been proved to be excellent from the point of view of radiation resistance [3], [4]; they are immune to high magnetic field and they can be operated safely down to -20°C , according to producer indications.

B. Experimental Setup

The measurement setup is schematically drawn in figure 1. A 2 km SM fibre has been used between modulator and receiver, a distance which is exceeding by far and large any possible application in SLHC detectors. The CW laser reaches the modulator via a 2 m PMF (with an optical power of 1 mW at 1550 nm wavelength) while the power at receiver input is equal to -7 dBm .

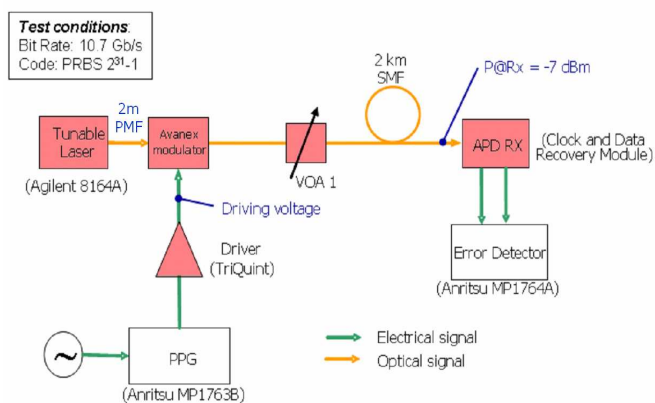

Figure 1: Schematic drawing of the measurement setup

The physical dimensions of the 10Gb/s modulator are $(48.0 \times 9.3 \times 5.0) \text{ mm}^3$, plus fibre connections (13 mm IN and 18 mm OUT). The transmission bit rate is set to 10.7 Gb/s, with a pseudo-random bit sequence (PRBS) $2^{31}-1$.

III. RESULTS AND DEVELOPMENTS

A. Results

The Bit Error Ratio (BER) was measured varying the amplitude of the RF signal driving the modulator. As shown in figure 2, a BER equal to 10^{-12} can be reached already at a driving voltage of 0.6 V_{pp} over the 50 Ω impedance of the modulator input. Such a low driving voltage may greatly help in the use of EOMs as elements of the architecture of SLHC tracking detector readout systems; this feature avoids the need of higher voltages (usually 3 to 5 V) solely dedicated to data link operation.

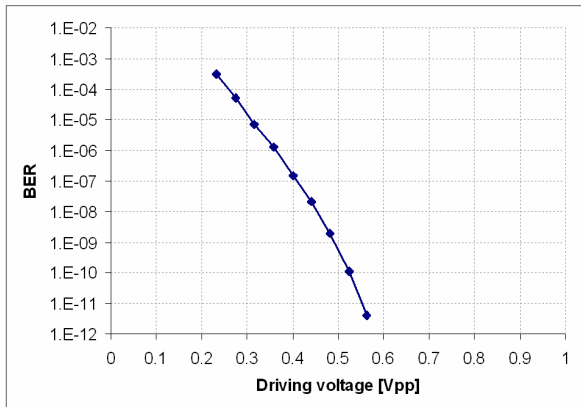

Figure 2: Measurement of Bit Error Ratio vs driving voltage

The above result opens up the possibility of driving the modulators directly with buffered detection board digital signals

B. Developments and Applications

At SLHC, in a tracking semiconductor detector, the transmission data rate can be of the order of Tb/s/detection barrel layer, depending on type of the transmitted data [5]. The above figure implies the use of few hundred transmitters per layer at a digital rate of ≤ 20 Gb/s. The use of EOMs, which can presently reach speeds of 40 Gb/s, can avoid data transmission bottlenecks.

The modulator used in these measurements has a small package size, which is directly comparable to SFP+ standard dimensions; in any case, options to further reduce overall footprint are still open and under study. In the SLHC perspective, EOMs are not meant to be used on single detectors, but rather on the serialized output of a set of detectors, in order to efficiently use the available bandwidth and reduce the number of needed data links.

Tests with 1300 nm single mode fibre, together with a study of polarization effects over the fibre lengths relevant for SLHC detectors, are already planned.

IV. CONCLUSIONS

A demonstration of 10 Gb/s transmission with BER $< 10^{-12}$ on a 2 km fibre optics employing a driving voltage as low as $V = 0.6$ V_{pp} (on 50 Ohm impedance) is given. Further studies on polarization are ongoing, and form factor reduction is an option to be still explored. Integration on boards and serialization of data are necessary to cope with SLHC requests. The use of LN-EOMs may fulfil possible requests of faster than 10 Gbps/ devices while limiting the power and material budget imposed by the next generation of tracking detectors for high energy physics. This is the reason why LNM EOMs are attractive in the implementation of the next generation experiment optical-links.

REFERENCES

- [1] D. Janner, D. Tulli, M. García-Granda, M. Belmonte, V. Pruneri, Laser & Photon. Rev. 3, 301-313 (2009)
- [2] F. Lucchi, D. Janner, M. Belmonte, S. Balsamo, M. Villa, S. Giurgiola, P. Vergani, V. Pruneri, Opt. Express 15, 10739-10743 (2007)
- [3] CERN/DRDC 93-35 RD23/Status Report
- [4] Cheng-Chih Lai et al., IEEE Photon. Tec. Letters, vol. 19, no. 13, July 1, 2007
- [5] G.Barbagli, F.Palla, G.Parrini, TWEPP-07 proc., 482-486