

Detector Control System for the Electromagnetic Calorimeter of the CMS experiment

P. Adzic¹, A. Brett⁷, D. Di Calafiori², F. Cavallari³, Wan-Ting Chen⁹, G. Dissertori², Apollo Go⁹, R. Gomez-Reino⁴, A. Inyakin⁵, D. Jovanovic⁶¹, G. Leshev⁸², A. Singovski⁵, Syue-Wei Li⁹, E. Di Marco³, P. Milenovic²¹, X. Pons⁴, T. Punz², J. Puzovic⁶¹, S. Zelepoukin⁸²

¹VINCA Institute, Belgrade, Serbia, ²ETH Zurich, Switzerland, ³INFN, Rome, Italy, ⁴CERN, Geneva, Switzerland, ⁵University of Minnesota, USA, ⁶University of Belgrade, Serbia ⁷Fermi National Accelerator Lab. ⁸University of Wisconsin, Madison ⁹National Central University, Taiwan

Peter.Adzic@cern.ch, Angela.Brett@cern.ch, Francesca.Cavallari@cern.ch, Diogo.Di.Calafiori@cern.ch, Wan-Ting.Chen@cern.ch, Apollo.Go@cern.ch, Guenther.Dissertori@cern.ch, Robert.Gomez-Reino.Garrido@cern.ch, Alexandre.Inyakin@cern.ch, Dragoslav.Jovanovic@cern.ch, Georgi.Leshev@cern.ch, Alexander.Singovski@cern.ch, Syue-Wei.Li@cern.ch, Emanuele.Di.Marco@cern.ch, Predrag.Milenovic@cern.ch, Xavier.Pons@cern.ch, Thomas.Punz@cern.ch, Jovan.Puzovic@cern.ch, Serguei.Zelepoukine@cern.ch

Abstract

The Compact Muon Solenoid (CMS) is one of the general purpose particle detectors at the Large Hadron Collider (LHC) at CERN. The challenging constraints on the design of one of its sub-detectors, the Electromagnetic Calorimeter (ECAL), required the development of a complex Detector Control System (DCS). In this paper the general features of the CMS ECAL DCS during the period of commissioning and cosmic running will be presented. The feedback from the people involved was used for several upgrades of the system in order to achieve a robust, flexible and stable control system. A description of the newly implemented features for the CMS ECAL DCS subsystems will be given as well.

I. INTRODUCTION

CMS construction work has been finalised at Point 5 near Cessy (France). One of the most accurate, distinctive and important detector systems of the CMS experiment is the high precision Electromagnetic Calorimeter (ECAL). It will provide measurements of electrons and photons with an excellent energy resolution (better than 0.5% at energies above 100 GeV [1]), and thus will be essential in the search for new physics, in particular for the postulated Higgs boson.

The calorimeter is designed as a homogeneous hermetic detector based on 75848 Lead-tungstate (PbWO₄) scintillating crystals. The structure of ECAL [1] is subdivided in three main parts: Barrel (EB) part, End-cap (EE) part and Preshower (ES). Avalanche Photo Diodes (APD) and Vacuum Phototriodes (VPT) are used as photodetectors in the barrel part and in the end-cap parts of the detector, respectively [1]. The barrel consists of 36 supermodules (SM) forming a cylinder around the interaction point. The EEs are the structures which close both ends of this cylinder and each of them is formed by two half disks named DEEs. The ES follows the EE's shape and is placed in front of it. All these components and front-end (FE) readout electronics inside the ECAL satisfy rigorous design requirements in terms of their response time, signal-to-noise ratio, immunity to high values of the magnetic field induction (up to 3.8T in the barrel part of the ECAL) as well as in terms of radiation tolerance (expected equivalent doses of up to 5 kGy and neutron fluence of up to

10^{12} neutrons/cm²) [1]. However, it has been shown that the light yield of PbWO₄ crystals and the amplification of the APDs are highly sensitive to temperature and bias voltage fluctuations [2, 3]. Therefore, the usage of these components has directly imposed challenging constraints on the design of the ECAL, such as the need for rigorous temperature and high voltage stability. At the same time, possible changes in the crystal transparency, which can be induced by the radiation, imposed additional requirements for monitoring of the crystal transparency [1]. For all these reasons specific ECAL DCS sub-systems had to be designed.

The implemented ECAL DCS consists of both hardware systems and controls applications [4] (Figure 1). Its monitoring hardware consists of the ECAL Safety System (ESS) and the Precision Temperature and Humidity monitoring (PTHM).

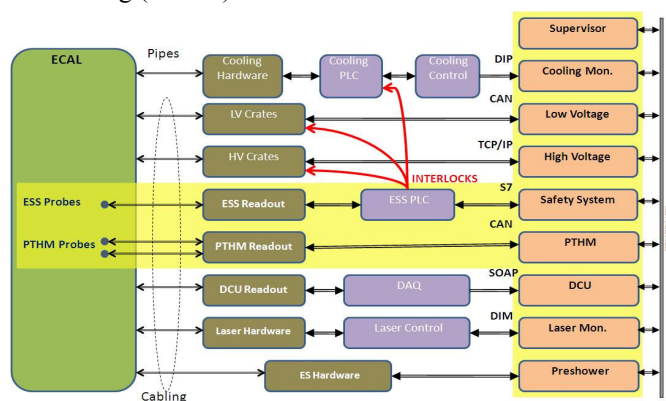

Figure 1: CMS ECAL DCS block diagram (simplified)

The ECAL DCS applications are responsible for the control of systems which provide necessary services for the ECAL. These include: Supervisor, Low Voltage (LV), High Voltage (HV), ESS Air Temperatures, ESS, PTHM, Detector Control Unit (DCU) Monitoring, Cooling Monitoring, Laser Monitoring, ECAL VME Crates Control and the ES Control and Monitoring.

II. HIGH VOLTAGE AND LOW VOLTAGE SYSTEMS

The APDs require a power supply system with a stability of the bias voltage of the order of few tens of mV. For this reason, a custom HV power supply system has been designed for the CMS ECAL in collaboration with the CAEN Company [5]. The system is based on a standard control crate (SY1527) hosting eight boards especially designed for this application (A1520PE). Up to nine channels can be hosted on a single A1520PE board and each channel can give a bias voltage of up to 500 V with a maximum current of 15 mA. The operating APD gain of 50 requires a voltage between 340 and 430 V. In total, there are 18 crates and 144 boards for the barrel. The SY1527 crate communicates with a board controller via an internal bus and is operated by the ECAL DCS via an OPC server.

In the endcaps, by default all VPTs are operated at anode and dynode voltages of 800 and 600 V, respectively. The VPTs require a stability of the bias voltages of about 10 V. The HV system is based on standard CAEN control crates (SY1527) each hosting two off-the-shelf HV boards (A1735P). Up to six pairs of channels can be hosted on a single A1735P board and each channel can give a bias voltage of up to 1500 V with a maximum current of 7 mA. There is 1 crate for each of the 2 endcaps. The power supplies are complemented by a custom-designed 84-way distribution system [Rutherford Appleton Laboratory, DEG 547/548] which incorporates additional protection circuitry and a clean method to operate each of the 84 channels at one of three different pairs of bias voltages.

The ECAL digitization electronics located on the very front-end (VFE) electronics cards require also a very stable low voltage to maintain constant signal amplification. The system uses low voltage regulators that guarantee this stability. The power is supplied by the LV system that is based on multichannel MARATON LV power supplies (PS) from Wiener [6]. Two types of LV PS are used: a type with six channels of 8V/110A (660 W) and a type with five channels of 8V/110A (660 W) and two channels of 8V/55A (330 W). In total there are 108 PS for the ECAL barrel and 28 PS for the ECAL end-cap. All the LV PS are water-cooled and operated by three ECAL DCS PCs via CAN-bus and an OPC server.

III. COOLING SYSTEM

The ECAL Cooling system employs the water flow to stabilise the detector to 18 °C within 0.05 °C. Each supermodule and each end-cap is independently supplied with water at 18 °C. The water runs through a thermal screen placed in front of the crystals which thermally decouples them from the silicon tracker, and through pipes embedded in the aluminium grid in front of the electronics compartments. Regulation of the water temperature and the water flow, as well as the opening of valves is performed by a dedicated Siemens PLC system. This system is operated by a PC via S7 connection and monitored by the ECAL DCS.

IV. PRECISION TEMPERATURE AND HUMIDITY MONITORING (PTHM)

The purpose of the temperature monitoring system is to provide precision temperature measurements and to monitor the stability of the temperature distribution in the environment of the ECAL crystals and photo-detectors. In addition, it should provide archiving of the temperature distribution history for the use in the ECAL data processing.

In order to provide this functionality, 360 high quality NTC thermistors [7] with very good long-term stability are installed in the ECAL supermodules and 80 more are installed in the ECAL end-cap Dees. Sensors are individually pre-calibrated by the manufacturer and then tested and sorted in the lab to ensure a relative precision better than 0.01 °C.

The purpose of the humidity monitoring system is to measure the relative humidity (RH) of the air inside the ECAL electronics compartments and to provide early warnings about high humidity conditions that may potentially lead to water condensation inside the detector. There are 176 HM sensors with 5-7% RH precision [8] placed inside the ECAL.

The readout system of the PTHM system is based on ELMB modules designed by the ATLAS experiment [9] (Figure 2).

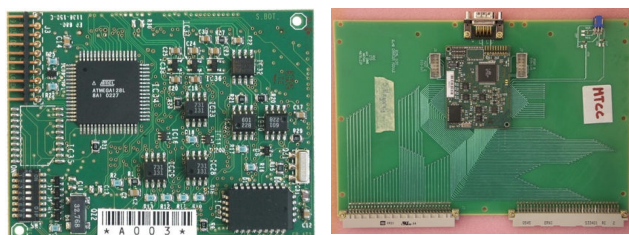

Figure 1: ELMB and PTHM electronic boards with ELMB.

Both temperature and humidity sensor samples were tested for their capability to work in an environment with high radiation levels and strong magnetic field that will be present in the ECAL region of CMS. Sensors have shown to be able to maintain their operational parameters unchanged during the expected running life time of the ECAL.

After the raw sensor signals are digitized with the ELMB's ADC, the data are sent by the ELMB's microcontroller via CAN bus to the DCS PC hosting the PTHM application, which is located in the CMS service cavern (USC). All ELMBs located within the crates inside one rack are connected to a single multi-point CAN bus.

The performance of the PTHM readout system in terms of resolution and noise levels has proved to be outstanding. Temperature fluctuations from the noise introduced in the system are of the order of 0.001 °C in the range of 18 - 22 °C.

V. ECAL SAFETY SYSTEM (ESS)

The purpose of the ESS [4] is to monitor the air temperature of the ECAL electronics environment (expected to be in the range of 25 - 32 °C), to monitor water leakage sensors routed inside the electronics compartments, to control the proper functioning of the ECAL Cooling and LV Cooling

systems and to automatically perform safety actions and generate interlocks in case of any alarm situation.

In order to achieve these goals 352 EPCOS NTC thermistors [10] are positioned in redundant pairs at the centre of each module of the ECAL barrel supermodules and at four locations inside each quadrant of the ECAL end-cap Dees. In accordance with the design objectives, the ESS temperature sensors are calibrated to a precision of 0.1°C. The functionality of the water leakage detection has been based on commercial water leakage sensor-cables provided by RLE Technology [11].

The temperature and water leakage sensors of the ESS are read out by the front-end part of the readout system, which comprises 12 ESS Readout Units (RU) located in the CMS experimental cavern. Each ESS RU represents an electrically and logically independent entity that can support up to four supermodules or up to two end-cap Dees.

In order to provide a reliable and robust readout system, the ESS RUs have been designed in a completely redundant way. Each redundant part of one RU is equipped with a RS485 interface and based on a Microchip PIC micro-controller and a so-called RBFEMUX block of electronics. This block of electronics inside the ESS RU provides intelligent sensor information multiplexing, as well as the digital implementation of a resistance bridge (RBFE) for removal of different readout signal dependencies on voltage offsets, thermocouple effects, power supply and ambient temperature drifts etc. Information from the temperature sensors from four input ports of one RU is mixed between its two redundant parts in a way which minimizes the possibility of losing temperature information inside the ECAL due to malfunctioning of an ESS RU component.

The part of the system where sensor information is processed and interlocks are accepted/generated is based on the industrial Siemens Programmable Logic Controllers (PLCs). The ESS PLC system has been designed and built as a redundant and distributed set of modules from S7-400 and S7-300 families. Since one of the main objectives of the ESS is a very high degree of reliability, a specific ESS multi-point communication protocol that provides reliable information exchange between ESS RUs and ESS PLC also had to be designed.

Both ESS sensors and electronics of ESS RUs were tested for radiation tolerance to appropriate doses and showed no shift in any parameter, while the cross section for single-event effects was proven to be negligible [12].

The ESS performance has been tested during the ECAL integration and test-beam periods in 2006 and 2007, as well as during the ECAL commissioning in 2008 and 2009. The system has shown the expected reliability. At the same time, its temperature readout system has shown to have a relative precision better than 0.02 °C.

VI. ECAL DCS SOFTWARE

ECAL DCS applications have been developed using the commercial ETM SCADA (Supervisory Control And Data Acquisition) software PVSS [13]. The version currently used is 3.8 on top of which the CERN ITCcontrols group has added

Joint Control Project (JCOP) framework components [14]. The ECAL DCS is implemented using these technologies and is now integrated with the central CMS DCS within the Finite State Machine framework, which provides hierarchical control and monitoring of CMS and ECAL.

A. The Supervisor

The Supervisor has been designed to be connected to all ECAL DCS subsystems and to centralize the control and the monitoring of all interactions between them. From the main Supervisor panel, the operator can monitor the status of all subsystems, instantly find the source of possible problems, issue commands to the LV, HV and ECAL VME Crates Control subsystems and manually shutdown the whole detector or parts of it in case of any problem.

The Supervisor application also handles the automatic controlled shutdown of detector's partitions, with granularity at the level of one SM/DEE. This mechanism follows a very simple logic (Fig. 3): The shutdown of the concerned partition is triggered if any of the subsystems/applications which monitor the detector's conditions (such as air temperature, water temperature and humidity) change into the ERROR state.

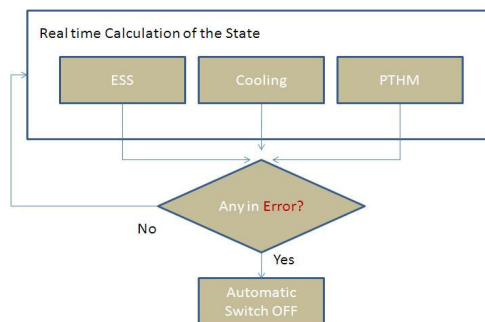

Figure 3: Automatic shutdown logic implemented in the ECAL DCS software framework.

B. Low voltage

The full application runs on three separate computers due to the limitation on the number of CAN branches per KVASER CAN adapter and in order to reduce the load per CPU, as the WIENER OPC server is rather resource intensive. A dedicated mechanism cross-checks the desired inhibits pattern against the inhibit configuration actually loaded into the crate.

C. High Voltage

The control and monitoring of all the 1240 CAEN high voltage channels are handled by this application [1,3], which runs on four separate computers in order to reduce the load per CPU.

Because of the specific properties of the crystals used for the barrel part of the ECAL, a unique voltage should be set to each of the APDs. This functionality has been implemented in the controls software for the HV subsystem.

D. Safety System

The experience acquired during the operations showed the need for separating the part of the application that is used for

the control system from the part that represents the safety system itself. As a consequence, the “SM/DEE Air Temperatures” subsystem was created. It includes the ESS sensors information only. Its error conditions are used as a trigger for the DCS automatic controlled shutdown (via software) of the concerned partitions.

E. Precision Temperature and Humidity Monitoring

It is fully implemented under the ECAL Supervisor. The structure of the software application was optimized several times during the detector’s running period. The final software solution is used to trigger automatic shutdowns on the Supervisor’s level in case of abnormal situations.

F. Detector Control Unit Monitoring

The DCU monitoring application was re-designed in order to provide DCU data as information to the shifter, without any automatic shutdown action in case of abnormal readings.

G. Cooling Monitoring

This application [3] only monitors all the relevant data of the ECAL SM/DEE cooling system which are provided by the dedicated system. The Cooling Monitoring application is configured to trigger an automatic software shutdown of a specific detector partition before the ESS takes any action based on the cooling water temperature.

H. Additional Software Applications

There are several specific applications which were integrated under the ECAL Supervisor. These are:

1) ECAL Preshower

This part of the controls software was installed in August 2009, just before the start of the CMS global cosmic run.

2) ECAL DCS Laser Monitoring

It displays the relevant information which is sent by the Laser Control System.

3) ECAL VME Crates Control

Service implemented by the central CMS DCS and integrated under the ECAL DCS Supervisor as a tool, which provides remote control of the power of ECAL EB/EE VME crates.

VII. ECAL DCS OPERATIONAL EXPERIENCE

The period of commissioning and cosmic running was efficiently used to test the ECAL DCS hardware in the CMS environment, as well as all its interfaces to other systems. A permanent ECAL DCS expert on-call service was provided during the whole detector’s running period.

All shutdowns triggered by the CMS Safety System (DSS) and by the Magnet Safety System (MSS) were always correctly performed by the ESS.

The automatic software shutdown mechanism has proven to be very efficient. The most common triggers for such

shutdowns were failures of the CMS primary cooling circuit. In all of these situations the ECAL DCS has smoothly switched off the detector power before any action of the ESS was necessary.

The ECAL DCS software components were constantly upgraded in order to fulfil all relevant user’s requests and consequently to move towards an optimal system. The CMS ECAL DCS has reached a fully operational and stable configuration. From the operational point of view the system can be considered ready for the LHC startup, which is foreseen for November 2009.

VIII. REFERENCES

- [1] CMS Collaboration, “The Electromagnetic Calorimeter Technical Design Report”, CERN/LHCC 97-33 (1997).
- [2] A.A. Annenkov, P. Lecoq and M.V. Korzhik: “Lead Tungstate scintillation material”, NIM A490 (2002) 30.
- [3] Z. Antunovic et al.: “Radiation hard avalanche photodiodes for the CMS detector”, NIM A537 (2005) 379.
- [4] P. Adzic et al., “The Detector Control System for the Electromagnetic Calorimeter of the CMS Experiment at LHC”, International Conference on Accelerator and Large Experimental Physics Control Systems, Knoxville, Tennessee, USA, 15 – 19 Oct 2007, pp.190-192
- [5] A. Bartoloni, “The power supply system for the CMS-ECAL APDs”, Proceedings of 7th Workshop on Electronics for LHC Experiments LEB 2001, Stockholm, Sweden, CERN-2001-005 (2001), 358.
- [6] WIENER MARATON highest density Power Supply for Hostile Environment, <http://www.wiener-d.com/M/22/51.html>
- [7] NTC thermistors 100K61A from Betatherm, <http://www.betatherm.com/>
- [8] RH sensors UPS-600 from Ohmic instruments, <http://www.cweb5.com/ohmic/>
- [9] B. Hallgren et al., The Embedded Local Monitor Board (ELMB) in the LHC Front-end I/O Control System, presented at the 7th Workshop on Electronics for LHC Experiments, Stockholm, Sweden, September 2001.
- [10] EPCOS AG, NTC thermistor 470Ω@25°C, ordering code B57211V2471J060, <http://www.epcos.com/>
- [11] RLE's patented Water Leak Detection Cable (SC), <http://www.rletech.com/products/cable.html>
- [12] P. Milenovic et al., “Performance of the CMS ECAL safety system for Super Modules SM0 and SM1”, Nucl. Instrum. Meth. A **554** (2005) 427.
- [13] ETM professional control: Prozess Visualisierungs und Steuerungs System SCADA tool, <http://itcobe.web.cern.ch/itcobe/Services/Pvss/welcome.html>.
- [14] M. Beharrell et al., Technology Integration in the LHC experiments’ Joint Controls Project, CHEP’01, Beijing, September 2001. <http://cern.ch/itco/Projects-Services/JCOP/>