

# DC-DC SWITCHING CONVERTER BASED POWER DISTRIBUTION VS SERIAL POWER DISTRIBUTION: EMC STRATEGIES

F.Arteche <sup>a</sup>, C. Esteban <sup>a</sup>, M. Iglesias <sup>a</sup>, C. Rivetta <sup>b</sup>, F.J. Arcega <sup>c</sup>, I. Vila <sup>d</sup>

<sup>a</sup>Instituto Tecnológico de Aragón, Zaragoza, Spain

<sup>b</sup>SLAC National Accelerator Laboratory, Stanford, CA 94025, USA

<sup>c</sup>Universidad de Zaragoza, Zaragoza, Spain

<sup>d</sup>IFCA (CSIC-UC), Santander, Spain

[farteche@ita.es](mailto:farteche@ita.es)

[rivetta@slac.stanford.edu](mailto:rivetta@slac.stanford.edu)

## Abstract

This paper presents a detailed and comparative analysis from the electromagnetic compatibility point of view of the proposed power distributions for the SLHC tracker up-grade. The main idea is to identify and quantify the noise sources, noise distribution at the system level and the sensitive areas in the front-end electronics corresponding to both proposed topologies: The DC-DC converter based power distribution and the serial power distribution. These studies will be used to define critical points on both systems to be studied and prototyped to ensure the correct integration of the system taking critically into account the electromagnetic compatibility. This analysis at the system level is crucial to ensure the final performance of the detector using non conventional power distributions, avoiding interference problems and excessive losses that can lead to catastrophic failures or expensive and un-practical solutions.

## I. INTRODUCTION

The up-grade for the tracker sub-system in both CMS and Atlas detectors are based on a front-end electronic (FEE) circuitry that requires ultra-low voltages to power-up the integrated circuits. This constraint forces to define new schemes of DC power distribution to bias efficiently the tracker front-end electronics, reducing the volume of the power conductors. The proposed power distribution schemes can be grouped into:

- Serial Power Distribution System
- DC-DC switching converter based Power Distribution System.

Both schemes are not conventional and have advantages and disadvantages.

The high magnetic field in the central detector does not allow to use magnetic materials in the switching power converter units for the proposed DC-DC converter based Power Distribution System. A large R&D effort is planned to develop unique DC-DC switching converters to operate under high magnetic field and particle radiation with minimum radiated and conducted noise emissions. The constraint imposed by the no-magnetic material design sets the conductive and radiated noise levels to a minimum that is higher than that achieved in conventional switching converters. Additionally, in this power distribution scheme,

DC-DC converters will be located near the FEE, within the tracker volume, increasing the coupling of interference between the power switching converters and the silicon detector / front-end electronic units.

Serial power distribution system has been already used in other small subsystems and experiments. This topology is mainly characterized by floating FEE. This requirement forces special design to keep low-impedance connection of the FEE to ground at high frequency, which may introduce undesirable effects due to imbalances in the HF ground connection. For that purpose, a special effort should be focused on the FEE design analyzing parasitic effects that have important impact in the performance of the system. Furthermore, in order to increase the efficiency, the serial power distribution plans to use DC-DC power converters as a primary power supply, which may increase the total interference of the system due to the conducted noise emission at the output. Those scenarios force to conduct electromagnetic compatibility studies on the proposed systems to be able to improve the noise immunity of the front-end electronics in order to assess compatibility with the noise generated by the power supply system.

CMS tracker power task force [1] has recommended that the baseline powering system for an upgraded CMS Tracking system should be based on DC-DC conversion, with Serial Powering maintained as a back-up solution. ATLAS upgrade has defined the final decision and keeps studying both proposals. In any case, electromagnetic compatibility between components in both the DC-DC switching converters based Power Distribution and the Serial Power Distribution topologies can be only achieved minimizing both the radiated and conducted noise emitted by the main noise sources and increasing the noise immunity of the FEE by a robust design.

This paper analyses the main elements that define the electromagnetic compatibility (EMC) of both power distribution systems and defines the impact of the system design and integration strategies in the compatibility of FEE. The main aspects (noise sources and FEE immunity) that define the electromagnetic compatibility of both topologies are presented. The integration aspects have strong impact in the system compatibility. However, if an EMC strategy is implemented at an early stage of the design, the compatibility between both the FEE and the proposed DC power distributions may be achieved.

## II. EMC ELEMENTS: NOISE SOURCES & IMPEDANCES

The two main elements that define the electromagnetic compatibility of any electronic system are noise sources and the impedances of the system.

The main noise sources in any electronic system are:

- *DC-DC converters* (conducted and radiated noise)
- *Electronic systems* (the current consumption is not constant (fast signals, clocks,..) and interact with the impedance of the power distribution system)

These sources usually define the noise emission level [2][3] of the system.

On the other hand, the element that usually defines the immunity of the system is the impedance of the circuit. It defines the coupling strength between the noise and interference and the sensitive parts of FEE. These impedances are conformed by the intrinsic impedance of components and the equivalent impedance defined by the coupling and parasitic impedances between the system and the mechanical structure. They depend strongly on the frequency range in study because above a certain frequency ( $\sim 1\text{-}5$  MHz) the stray components are a fundamental part of the impedance and direct connections between two points may not be considered low impedance connections. Also, the impedance of cables or conducting structures is important because it defines the ability of such systems to conduct, radiate or receive noise from other systems.

## III. NOISE DISTRIBUTION ON DC-DC CONVERTER BASED POWER DISTRIBUTION SYSTEM

Large amount of conducted noise in the tracker upgrade may be created by the switching mode power supplies (SMPS) installed close to FEE. SMPSs generate high frequency noise due to the switching action. This noise can propagate through power network, where it can be either radiated to other systems or conducted to the FEE, decreasing the performance of the detector. The FEE immunity will be directly related to the systems topology because the types of cables, grounding strategy and power network design define the ability of the system to bypass noise and interference currents from sensitive parts of FEE. Fig. 1 depicts a simple diagram of a possible topology of one leader of the Tracker upgrade. This topology is characterized by two important aspects that define the FEE-Power Distribution compatibility:

- The long distance between the ground of the leader and the local ground of each FEE may not be considered as the unique ground or equipotential structure at high frequency.
- The high number of DC-DC converters located very close to FEE and connected through a common power network.

Based on this scenario, the more important electromagnetic interference issues founded in the DC-DC converter based power distribution are:

1. Noise emission (radiated and conducted) effects at the output of the DC-DC converters.
2. Noise emission (radiated and conducted) effects at the input of the DC-DC converters.
3. Noise emission (radiated and conducted) effects in HV & MT lines
4. Grounding Noise effects between FEE and overall ground of the system.

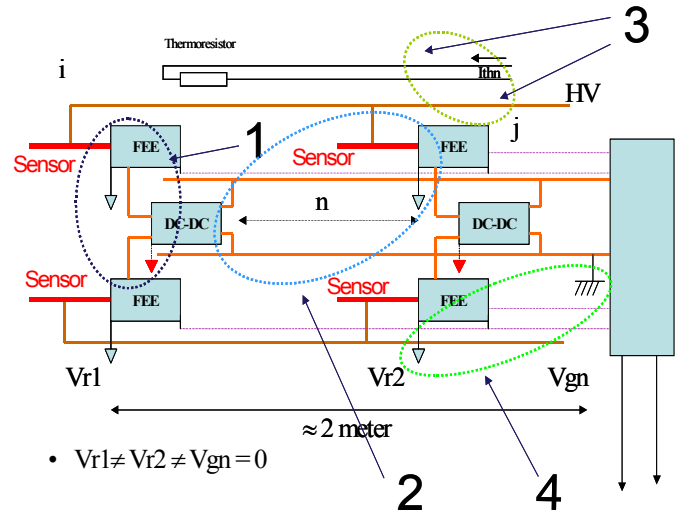

Figure 1: Noise sources on DC-DC converter based power distribution

### A. Output emissions effects of DC-DC converters

DC-DC converters emit radiated and conducted noise at the output, which can decrease the performance of the FEE. The output currents in DC-DC converters contain not only the DC components that contribute to the real power transfer, but also a large amount of harmonic components of the switching frequency. These harmonic components propagate out of the power supply as conducted electromagnetic interference emitted through the input and output cables [4][5]. The input/output is composed by two conductors (+, -) and a reference and the interference signals can be decomposed into two modes of propagation: Differential mode (DM) and Common mode (CM).

The DM noise is the direct result of the fundamental operation of the switching converter, whereas the CM noise often includes parasitic capacitive or inductive coupling. Selecting the adequate filtering strategy (capacitors with low series inductance and series resistance) and SMPS topology is possible to decrease the DM & CM emissions as well as radiated noise. The later one has significant importance in this distribution because the close distance between DC-DC converters and FEE. Fig. 2 depicts the mutual coupling between a group of power distribution conductors and the sensitive areas of FEE when the SMPSs and FEE are close enough.

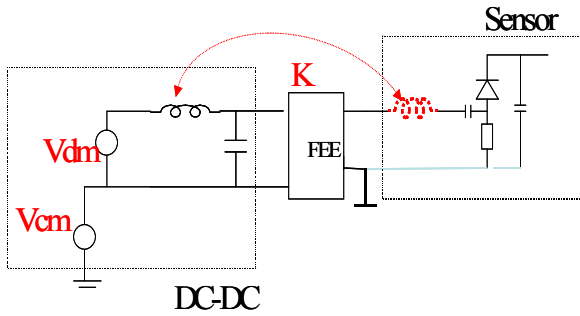

Figure 2: DC-DC converters output emissions

The layout and integration strategy have a strong impact on the system compatibility and most of all noise problems may be solved easily. As an example, there are several ways to ensure the compatibility between FEE and magnetic radiations emission from DC-DC converters. They are listed below:

- It is possible to define a common ground for the DC-DC and Sensor to cancel the CM
- It may be possible to design the inductor to avoid radiation
- It may be possible to design the FEE-Sensor in a way that it is immune to magnetic fields.

### B. DC-DC input noise emissions

DC-DC converters emit also conducted noise at the input. This noise emission can be coupled to other systems via direct conduction or radiated (electrically or magnetically) by power network or any cable present inside tracker volume. Fig. 3 shows the noise coupling mechanism associated to noise emissions at the input of a DC-DC power converter.

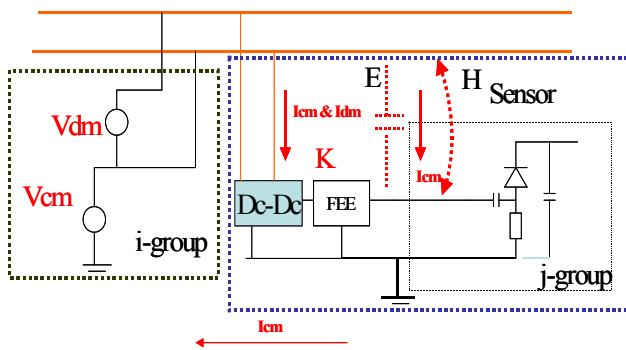

Figure 3: DC-DC converter input noise emissions

To solve this problem, the input of the SMPS must have filters and the power distribution network have to be properly designed. To minimize the mass in the tracker region and make a distribution network with low EMI emission, an integral design is necessary to satisfy both a good mechanical design and a structure electromagnetic compatible with the sensitive FEE. Proposal for the power distribution network implementation includes the design of PCB or custom networks based on twisted-pair cables and shields. The evaluation of those structures from the EMC point of view is critical to minimize the impact of interferences in the FEE. Solutions based on PCBs gives compact structures and it is easy to include filtering, but usually use more cooper in the

design. Combinations of PCBs and carbon fibre materials could give optimal designs with minimum mass and EMC with the FEE connected to the distribution network. Additionally, for the proposed power distribution, the SMPS will switch a very high frequency, above 1MHz, introducing harmonic components with considerable energy up to 100-200MHz in the rod. Therefore, studies of the power network from mechanical and EMC point of view are an important topic for future power network to define the key issues that have to be addressed in the development of power networks to increase the immunity of tracker system.

### C. HV & MT lines

Experience from the previous CMS tracker detectors [6] has showed that the slow control lines (MT) and high voltage (HV) lines are able to couple noise to sensitive parts of FEE. Slow control lines have been strongest coupling elements of noise and interferences for the tracker system. The new proposed scheme to power the tracker system based on DC-DC switching converters will produce large amount of noise inside the tracker volume. This noise can couple to the MT and HV lines and through them finally to the sensitive areas of the FEE. Particularly, in the past those lines included only filter to avoid external perturbation flowing through them, but within the volume of the detector only minimum by-passing filtering to ground have been included. Fig 4 shows a simplified scheme including the noise generation and distribution across HV and MT lines and the coupling with the FEE.

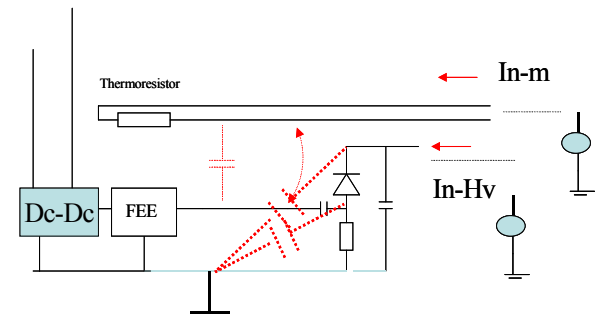

Figure 4: MT & HV line emissions

To design properly the MT and HV lines there are several approaches as good filtering and careful layout of the network. In the case of the MT lines, there are other solutions based on the substitution of these lines by optical fibres and optical transducers. The Fibre Bragg Grating (FBG) sensors have many enhanced features with respect to traditional electrical probes: no need for readout near the detector or sensor, no power cables; long term stability; immunity to electromagnetic fields, high voltages, extreme temperatures, and ionising radiation; simple multiplexing; etc. This solution reduces the EMI coupled by the MT line to the FEE to a minimum.

### D. GND noise

In large volumes and with minimum cooper mass it is very difficult to achieve an equipotential ground structure. Different areas of the structure and the sensitive parts of the FEE can have potential difference that will couple near-fields or CM currents in the FEE. The magnitude of this potential

difference is directly related to the characteristic of the ground connection. Fig. 5 depicts a simple scheme showing noise and interference coupling between the sensitive FEE located within the tracker volume and the surrounding structure.

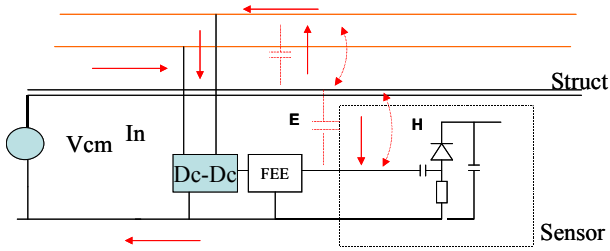

Figure 5: GND noise implications

Good grounding connection minimizing the impedance between the FEE and the structure is the solution to this problem but it is generally limited by mechanical constraints. In general the main characteristics that should be followed for the ground connections are:

- The ground connections should be short and flat.
- Routing path should be as close as possible to a conductive structure near the FEE.

#### IV. NOISE DISTRIBUTION ON SERIAL TOPOLOGY

Serial powering is the other option under study to power the Tracker upgrade. In the serial powering scheme a power supply, operating as current source, biases a set of detector modules connected in series. At that FEE module level, local shunt regulators provide the local voltage regulation per module. The voltage across the total chain of modules is  $n$  times the module voltage. The potential reference for each module is different. The serial powering scheme is composed by three main elements:

- Current sources
- Shunt regulator with distribution per module of digital and analogue power
- AC or opto-coupling of clock, command and data signals.

The serial powering scheme [7][8][9] is also characterized by the connection among analogue ground, digital ground and sensor bias ground, which are tied together on the module. Since the grounds or reference voltage of different modules are different, floating HV power supplies must be used. Figure 6 shows a simple diagram of a possible topology of the Tracker upgrade for ATLAS detector. This topology defines several noise issues that must be taken into account.

1. Noise emission (radiated and conducted) effects at the FEE level
2. Conducted Noise emitted by the power supply and coupled to the electronic system through the distribution network.
3. Noise coupled (radiated and conducted) through the HV and MT lines
4. Grounding Noise effects between FEE and GND.

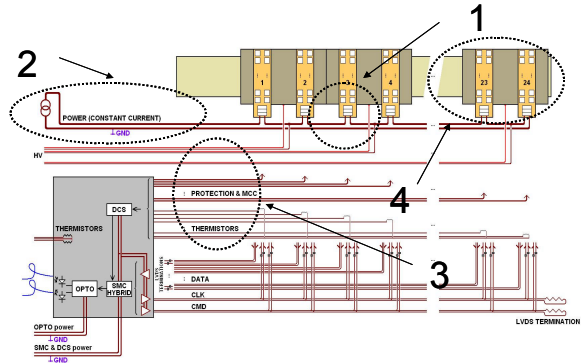

Figure 6: Noise emissions in the serial power distribution system (courtesy from Mark Weber [9])

#### A. FEE noise emissions

Electronics units generate noise in the power system because it operates with non-constant current consumption. The spectrum of the power supply currents for the FEE has low frequency components and high frequency components associated with the data rate and fast transitions signals. This current spectrum is mainly filtered by the LV regulators and high frequency capacitors by-passing the power lines and output terminals of the regulators. The voltage developed at the input power terminal of each module is defined by that filtering. Fig. 7 shows the effect of the input terminal voltage in the serial power distribution. Due to the series connection of the modules, the input terminal voltages are added and define the common mode voltage between the  $i^{\text{th}}$  module and the structure ground. This common mode noise in each module reference can couple noise to the FEE via the stray capacitance between the FEE/detector module and the structure.

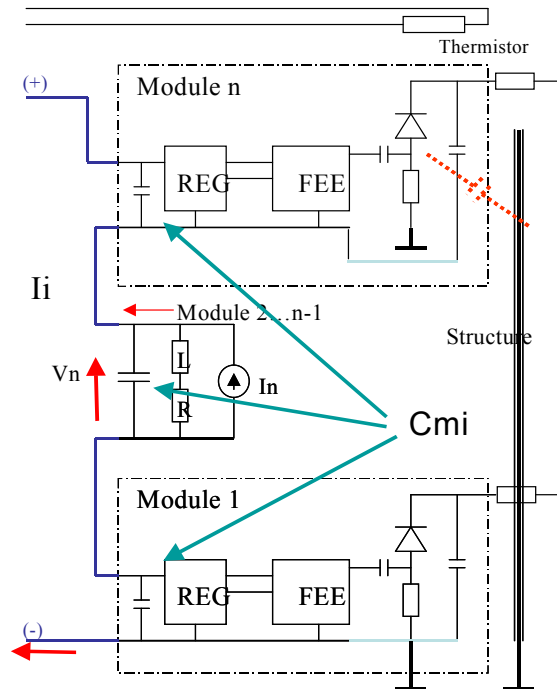

Figure 7: Common mode voltage per module due to the current module consumption.



## B. Primary power source

The primary power is also able to introduce noise into the serial powering system. The two main elements that may introduce noise are:

- Current source (primary power supply)
- Power cables

Power cables are the connection between the series module chain with the external world. Electromagnetic radiated noise generated by neighbouring sub-systems may couple to these cables and the interference distributed in the serial array. Primary power supply located outside of the tracker module array emits conductive and radiated interference that is coupled to the detector through the power cables. It is planned to develop these power supplies acting as current generator based on switching converters. These units will generate CM & DM in the same way that has been explained in section III and it may decrease the performance of the FEE as it has been already study in previous generation of CMS [5]. The current source operation of the power supply is only limited to low frequencies, above hundreds of kHz, any noise generated by the switching converter is not filtered. This noise should be cancelled by CM – DM filters in the power supply (Filter for a set of N modules). In the detector, it is important to filter the noise at the input power terminal of the overall distribution network. The interference flowing through the serial power distribution network is more difficult to filter for each module because there is no GND at module level. Additionally, as it is depicted in Fig. , the effect of interference currents flowing through the distribution network and the input impedance of the power terminal of each module develops a common mode voltage. This CM voltage affects more critically to those modules located far away from the unique GND connection. It is important to minimize for high frequency the input impedance of modules and the impedance of the power distribution network for common mode signal.

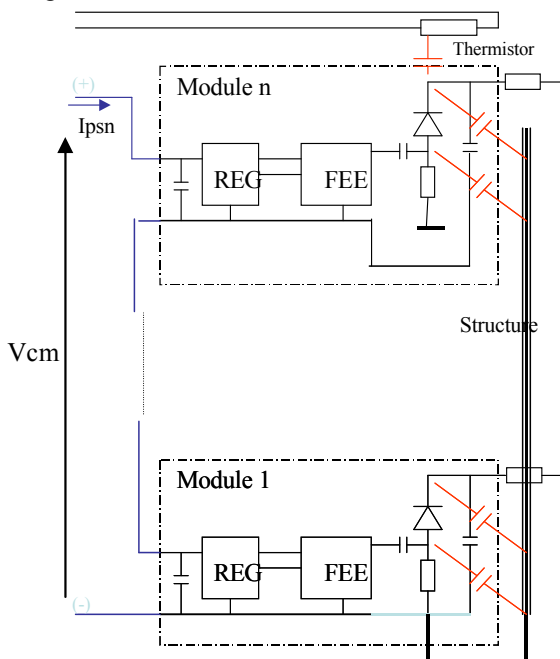

Figure 8: Effect of current source noise in the Serial Distribution.

## C. HV & MT lines

The noise effects from MT and HV lines are very similar to the one analyzed for the DC-DC converter based power distribution topology. Noise can be coupled to these lines from outside of the detector.

## D. Grounding effects

The GND effects in the serial power distribution are very important because the design has only a ground connection for one of the modules. There is not ‘explicit’ ground connection between the local reference per module and the structure. This special characteristic forces to consider the grounding at high frequency of each module from the design stage, being almost impossible or unpractical to change it during the commissioning stage. As it was analyzed in previous sub-sections, current interferences flowing through the serial power distribution develops common mode voltages that drives the reference voltage per module respect to the structure potential. Fig. 9 depicts the ground noise distribution on serial powering scheme. The stray component defines the return path for CM currents flowing through the FEE and induced by CM ground voltages. To increase the immunity of the system to ground voltages or potential differences is necessary minimize the stray capacitances between the structure and the detector and reduce the impedance at high frequency between modules and the structure. It requires an integral design of the grounding and ground connection of the modules at high frequency, minimizing the overall mass of the structure.

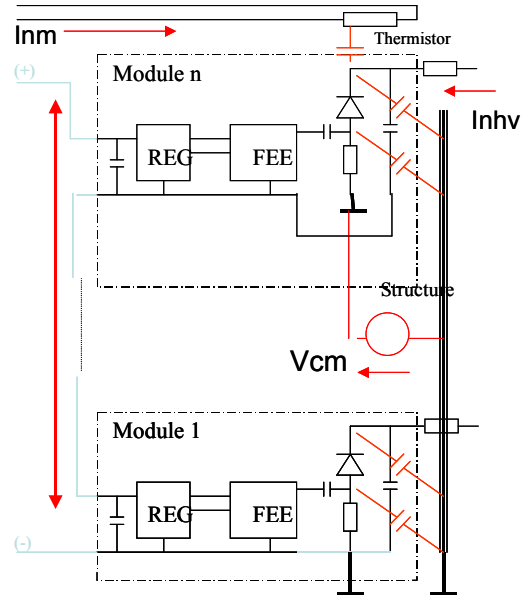

Figure 9: Noise induced by GND potential differences in serial distribution

## V. SUMMARY OF BOTH SYSTEMS

### A. DC-DC converters based power system topology

The DC-DC converter based power distribution system has several noise sources:

- DC-DC power converters
- MT & HV lines
- Cables and structures

The main characteristics of DC-DC converter based power distribution system are the close distance between the main noise source (DC-DC power converter) and the victim (FEE) and the high switching frequency of the DC-DC converters, around 1 MHz. These two elements force to take into account radiation effects (near and far field) that have not been considered in previous detectors. Additionally, the large number of DC-DC power converters located inside the tracker volume and connected to the same power network is critical. The interference current flowing through the power network will radiate EMI and has to be taken into account to define the safety margins in the compatibility between the immunity level of FEE and the emission level of DC-DC power converters at the input and at the output ports. All these elements may be controlled if an EMC strategy is implemented from the very beginning of the design. This strategy has to be focused on the grounding topology and the DC-DC converters, the FEE and sensor and the distribution network design.

### B. Serial system topology

Serial powering topology has also several noise sources:

- Electronics noise
- Current source (power supply)
- MT & HV lines
- Cables & structures

The two main characteristics of the Serial power distribution in terms of noise are the lack of local ground or grounding at the module level and the addition of inner noise sources or common mode voltages due to serial array. A critical element in the serial power distribution is the LV regulators and power filters per module. The internal impedance of those devices is critical to minimize the common mode voltage developed along the series distribution due to the current variations per module and interferences flowing through the distribution network.

The grounding topology have to be designed from the beginning because it is going to be unpractical or difficult to introduce changes during commissioning. Similar to the other distribution proposal, the grounding design suffers of an strong limitation that is the minimization of cooper material in the structure. That reason sets for an integral design for the grounding taking into account mechanical constraints as well as electromagnetic compatibility issues.

## VI. CONCLUSIONS

A general overview of the most important noise issues of both DC-DC converter based power distribution system and serial powering system has been presented. Noise issues in both systems are much more complex than in the past and introduce an important risk in terms of system performance.

They can not be solved during commissioning by means of try-error procedure. They require a systematic design approach including the electromagnetic compatibility of the system as a fundamental issue from the very beginning.

## VII. ACKNOWLEDGMENT

The authors would like to thank to Dr. Peter Sharp from Imperial College/CERN for helping us during the development of these studies. Also, we would like to thank to Instituto Tecnológico de Aragón (ITA), Zaragoza, Spain and specially Dr. J.L. Pelegay, head of Grupo de Investigación Aplicada (G.I.A.) for the support of this work. Finally, one of us (C.R.) wants to thank to US DOE, under contract DE-AC02-76SF00515, for the support of this work.

## VIII. REFERENCES

- [1] "Report of Power Task Force", January 2009
- [2] F.Arteche and C. Rivetta, "EMI Filter Design and Stability Assessment of DC Voltage Distribution based on Switching Converters", Proceedings of Workshop on Electronics for LHC Experiments, LEB 2001, Vol 1, pp353-357, September 2001
- [3] F. Arteche and C. Rivetta, "*Noise Susceptibility Analysis of the HF Front-End Electronics for the CMS High -Energy Experiment*", Proc. of IEEE Int. Symposium on EMC. August 2003, Boston, USA, pp. 718-723.
- [4] F. Arteche and C. Rivetta "*EM Immunity studies for front-end electronics in high-energy physics experiments*", Proc. of Int. Symposium on EMC, EMC Europe 2004. September 2004, Eindhoven, The Netherlands, pp. 533-538.
- [5] F. Arteche, C. Rivetta and F. Szonsco, "*Electromagnetic Compatibility Plan for the CMS Detector at CERN*", Proc. of 15th Int. Zurich Symposium on EMC, February 18-20, 2003, Zurich, Switzerland, pp. 533-538.
- [6] F.Arteche, C. Rivetta, "*Detector noise susceptibility issues for the future generation of High Energy Physics Experiments*", Proceedings of Workshop on Electronics for LHC Experiments – TWEPP 2008, Vol 1 , pp533-538,September 2008
- [7] Marc Weber, Giulio Villani, Mike Tyndel, Robert Apsimon, "*Serial powering of silicon strip detectors at SLHC*" Nuclear Instruments and Methods in Physics Research Section A: Accelerators, Spectrometers, Detectors and Associated Equipment, Volume 579, Issue 2, 1 September 2007, Pages 844-847
- [8] Mark Weber, "*Power distribution for SLHC trackers: Challenges and solutions*" Nuclear Instruments and Methods in Physics Research Section A: Accelerators, Spectrometers, Detectors and Associated Equipment, Volume 592, Issues 1-2, 11 July 2008, Pages 44-55
- [9] Mark Weber, "Serial Powering discussion", Power task force meeting, December 2008