

# EUROPEAN ORGANIZATION FOR NUCLEAR RESEARCH CERN - ACCELERATORS AND TECHNOLOGY SECTOR

CERN-ATS-2010-008

## THE LOW-LEVEL CONTROL SYSTEM FOR THE CERN PS MULTI-TURN EXTRACTION KICKERS

J. Schipper, B. Bleus, C. Boucly, E. Carlier, T. Fowler, H. Gaudillet, R. Noulibos, L. Sermeus

### Abstract

To reduce the beam losses when preparing high intensity proton beam for the CERN Neutrino to Gran Sasso (CNGS) facility, a new Multi-Turn extraction (MTE) scheme has been implemented in the PS, to replace the present Continuous Transfer (CT) to the SPS. Industrial off-the-shelf components have been used for the low-level part of the MTE kicker control system. National Instruments PXI systems are used to control the high voltage pulse generators and a SIEMENS programmable logic controller (PLC) handles the centralised oil cooling and gas insulation sub-systems.

CERN-ATS-2010-008  
04/01/2010



Presented at the 12th International Conference on Accelerator and Large Experimental Physics Control Systems  
(2009 ICALEPCS) - October 12-16, 2009 - Kobe, Japan

Geneva, Switzerland

January 2010

## THE LOW-LEVEL CONTROL SYSTEM FOR THE CERN PS MULTI-TURN EXTRACTION KICKERS

J. Schipper, B. Bleus, C. Boucly, E. Carlier, T. Fowler, H. Gaudillet, R. Noulibos, L. Sermeus, CERN, Geneva, Switzerland.

### Abstract

To reduce the beam losses when preparing high intensity proton beam for the CERN Neutrino to Gran Sasso (CNGS) facility, a new Multi-Turn extraction (MTE) scheme has been implemented in the PS, to replace the present Continuous Transfer (CT) to the SPS. Industrial off-the-shelf components have been used for the low-level part of the MTE kicker control system. National Instruments PXI systems are used to control the high voltage pulse generators and a SIEMENS programmable logic controller (PLC) handles the centralised oil cooling and gas insulation sub-systems.

### INTRODUCTION

The new PS Multi-Turn extraction (MTE) scheme [1], which is intended to replace the present Continuous Transfer (CT), is based on a fast bump around the magnetic septum SMH16 (Fig. 1). Fast pulsed kicker magnets, located in straight sections (SS) 13 and 21 (KFA13 and KFA21), create a nearly closed bump for the beamlets in the first four turns. To close it perfectly, an existing kicker in SS9 (KFA9) will be used. The core beam needs to be moved out by more than twice the distance of the other four beamlets. One additional kicker, located in SS4, kicks out the remaining beam in the fifth turn, in conjunction with the existing KFA71-79 system. Two existing fast dipoles in the TT2 transfer line will be used to correct the trajectory of the beamlets, to reduce the beam-emittance in the SPS.

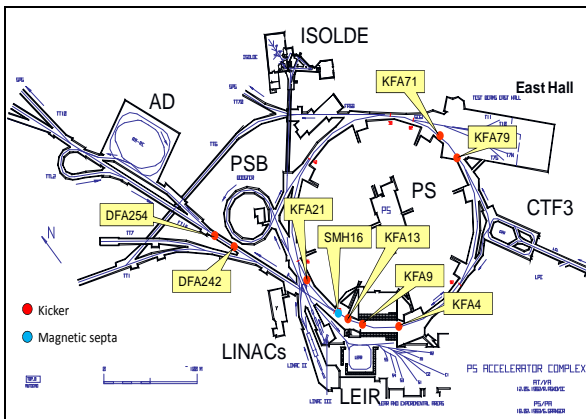

Figure 1: PS complex layout, indicating the location of the fast pulsed magnets and the magnetic septum SMH16 implied in the new PS multi-turn extraction scheme.

The system is being implemented in two phases. The first phase, discussed in this paper and completed in 2008, concerns the KFA13/21 and KFA4 subsystems, together with the existing KFA71-79 and BFA9 systems.

In Fig. 2, the MTE kicker generators can be seen installed, with the blue Pulse Forming Networks (PFN) on the ground floor and the kicker control electronics in the green racks on the platform.



Figure 2: MTE kicker generators.

### HV PULSE GENERATOR HARDWARE CONFIGURATION

A typical PS kicker magnet installation comprises a number of individual pulse generator modules grouped together to perform a single function or a number of different functions. For the MTE system, KFA4, KFA13 and KFA21 are seen by the control system as independent generators; they communicate directly via Ethernet with the front-end computer (FEC) (Fig. 3).

The kicker control system is fully multi-user compatible allowing different settings per machine cycle with a minimum machine cycle length of 1.2 sec.

The control system can be divided into two parts, the front-end computer and the pulse generator controller.

#### Front-end computer

The FEC, a VME-based system running LynxOS, is the master and data concentrator for all the generator controllers.

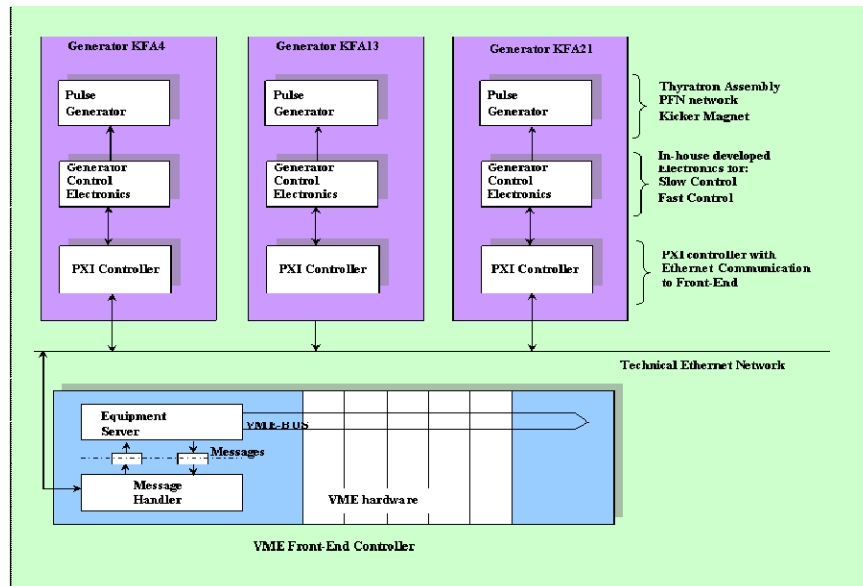

Figure 3: Kicker generator control layout.

### *Pulse Generator Controller*

The pulse generator control electronics is typically configured to service the various sub-components like thyatron timing, PFN reference and acquisition voltages, PFN charging/discharging protection and thyatron protection.

A PXI (PCI eXtensions for Instrumentation) controller from National Instruments forms the communication layer and is implemented in between the generator hardware control and the FEC. This PXI system contains a CPU with a LabVIEW Real Time embedded controller and an FPGA card with reconfigurable I/O which communicates with the generator electronics. In the medium term it is foreseen to progressively integrate all in-house designed generator electronics shown in Fig.3 into the PXI platform.

## **HV PULSE GENERATOR SOFTWARE CONTROL**

### *Front-end computer*

The CERN developed Frontend Software Architecture (FESA), a C++ based control package, is used for the control of the MTE kickers. This package provides a complete environment for the equipment specialists to design, develop, deploy and test their equipment software by creating a FESA class. The FESA class performs the publication of the various equipment functions to the application layer.

The program is interrupt driven by external timing events received by the timing module which is installed in the VME crate. These events are received at every machine cycle and activate control and acquisition

routines. The FEC communicates with the PXI controllers by means of the LabWindows/CVI Network Variable Library, using the so-called shared variables and the National Instruments Publish-Subscribe protocol (NI-PSP).

With the help of the FESA infrastructure, functions like alarms, data logging and fault history have been added as diagnostic tools.

### *PXI Software Configuration*

All PXI software development is made with LabVIEW (National Instruments). LabVIEW programs/subroutines are called virtual instruments (VIs). The main VI, the heart of the control system, runs on the PXI-CPU under Pharlap OS. It is event driven and a slave of the FEC and waits for events coming from the FEC controller.

The main VI communicates with the FPGA VI, which is linked to the generator hardware and performs timing control tasks, PFN voltage measurements, reference voltage settings, interlock/status readout and generator control functions.

The published data to the application layer can be accessed with LabVIEW via a CMW (Common Middleware) wrapper, a tool from the RADE package available at CERN. RADE is a Rapid Application Development Environment based on LabVIEW and a CERN-supported solution proposed to develop expert tools, machine development analysis and independent test facilities in communication with the CERN control systems.

## **OIL AND GAS SUB-SYSTEM CONTROL**

Due to the complexity of the oil distribution system used for insulation and cooling of the thyatron switches

and of the SF<sub>6</sub> gas system used for insulation of the PFN cable and magnet tank feed through boxes, a process control system based on off-the-shelf industrial programmable controller (PLC) has been introduced in the control architecture of the MTE kickers in order to facilitate the operation, the monitoring and the diagnostic of the complete system.

The system has been designed with a modular approach where each high voltage generator is associated with an individual oil cooling unit including oil/water heat exchanger, circulating pumps, regulation valve and the requested instrumentation like temperature sensors, flow and pressure meters. The process control has been implemented within a SIEMENS S7-300 PLC and can be operated either locally through an industrial touch panel or remotely via a supervisory system.

When in local, in addition to a complete overview of the cooling process (Fig.4), the operator has the possibility to launch automatic sequences for draining and filling individually each oil container or oil tank, to optimise regulation loops and to calibrate and adjust interlock thresholds. When in remote mode, an equipment expert can remotely monitor and control the cooling system through a web based application implemented within the SIEMENS WinCC supervisory system. The following functions have been published: secure high level control of cooling unit, online and offline analysis of different regulation process parameters (pressure, flow, and temperature), system state surveillance, error and alarm reporting for diagnostic before intervention or preventive maintenance.

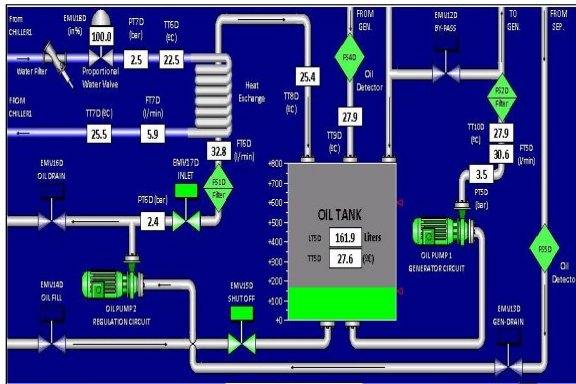

Figure 4: Oil tank control specialist application.

The oil & gas control architecture is composed of a SIMATIC S7-300 master PLC interfacing through a PROFIBUS-DP fieldbus deported IO for access to the different actuator and sensors.

## SAFETY CONTROL

For the KFA13 and KFA21 magnets, three complete high voltage generators, two operational and one spare, have been installed. In order to avoid interconnection errors at the level of the transmission lines, a safety protection system has been implemented to monitor the

connections of the transmission lines between the high voltage generators located in a surface building and the magnets located in the PS accelerator tunnel, and to interlock the complete system in case of discordance. Furthermore, this safety system will have to guarantee the security of the operator working on the installation in case of an intervention.

Two levels of safety protection have been implemented in order to avoid to pulse the installation under unsafe conditions.

The *level 1* safety protection prevents any charge of the PFN under unsafe conditions. It is connected to the interlock unit and is used to ensure that the transmission cables are properly connected. Safety conditions to be validated before authorisation to pulse the installation include:

- The surveillance of the transmission cable connections on each generator and its associated magnet;
- The surveillance of internal hardware and software state.

The *level 2* safety protection stops the electrical distribution in case of emergency or in case of the opening of the high voltage circuit. Safety conditions to be validated before authorisation to supply the installation include:

- The surveillance of all emergency stops in the powering area and in the tunnel near the magnet location;
- The surveillance of all the electrical protection micro-switches on each generator.

In addition, the safety protection system multiplexes the generator measurement signals and its associated magnet measurements signals in accordance with the operational configuration and distributes these signals to local scopes for performance follow-up and diagnostic features.

## CONCLUSION

The introduction of PXI in accelerator controls offers an interesting alternative to existing technologies, not only because of its integration into the CERN controls system by means of RADE, but also because of its flexibility and ease of use. On the other hand the PLC provides a highly efficient solution for the control of processes which can be realised on the basis of off-the-shelf industrial components, like the control of the oil and gas system. In addition, the possibility to implement safety functions within a PLC is today a real asset for the implementation of reliable and safe solutions.

## REFERENCES

- [1] The PS Multi-Turn Extraction Study Group, "The CERN PS Multi-Turn extraction based on beam splitting in stable islands of transverse phase space. Design Report", CERN-2006-011; <http://ab-project-mte.web.cern.ch/AB-Project-MTE/>.