

EUROPEAN ORGANIZATION FOR NUCLEAR RESEARCH
CERN — BEAMS DEPARTMENT

CERN-BE-Note-2010-002

EURISOL High Power Targets

Yacine Kadi¹, Jacques Lettry¹, Mats Lindroos¹, Danas Ridikas²,
Thierry Stora¹, Luigi Tecchio³

¹ CERN Geneva, Switzerland

² CEA Saclay, France

³ INFN Legnaro, Italy

Abstract

Modern Nuclear Physics requires access to higher yields of rare isotopes, that relies on further development of the In-flight and Isotope Separation On-Line (ISOL) production methods. The limits of the In-Flight method will be applied via the next generation facilities FAIR in Germany, RIKEN in Japan and RIBF in the USA. The ISOL method will be explored at facilities including ISAC-TRIUMF in Canada, SPIRAL-2 in France, SPES in Italy, ISOLDE at CERN and eventually at the very ambitious multi-MW EURISOL facility. ISOL and in-flight facilities are complementary entities. While in-flight facilities excel in the production of very short lived radioisotopes independently of their chemical nature, ISOL facilities provide high Radioisotope Beam (RIB) intensities and excellent beam quality for 70 elements. Both production schemes are opening vast and rich fields of nuclear physics research.

In this article we will introduce the targets planned for the EURISOL facility and highlight some of the technical and safety challenges that are being addressed. The EURISOL Radioactive Ion Beam production relies on three 100 kW target stations and a 4 MW converter target station, and aims at producing orders of magnitude higher intensities of approximately one thousand different radioisotopes currently available, and to give access to new rare isotopes. As an illustrative example of its potential, beam intensities of the order of 10^{13} ^{132}Sn ions per second will be available from EURISOL, providing ideal primary beams for further fragmentation or fusion reactions studies.

Published in *Nuclear Physics News*, Vol. 18, No. 3, 2008.

Subject: Targets for EURISOL

key words: Radioisotopes beams, high power targets, EURISOL, safety.

EURISOL High Power Targets

Introduction

Modern Nuclear Physics requires access to higher yields of rare isotopes, that relies on further development of the In-flight and Isotope Separation On-Line (ISOL) production methods. The limits of the In-Flight method will be applied via the next generation facilities FAIR in Germany, RIKEN in Japan, and RIBF in the United States. The ISOL method will be explored at facilities including ISAC-TRIUMF in Canada, SPIRAL-2 in France, SPES in Italy, ISOLDE at CERN, and eventually at the very ambitious multi-MW EURISOL facility [1]. ISOL and in-flight facilities are complementary entities. While in-flight facilities excel in the production of very short lived radioisotopes independently of their chemical nature, ISOL facilities provide high Radioisotope Beam (RIB) intensities and excellent beam quality for 70 elements. Both production schemes are opening vast and rich fields of nuclear physics research.

In this article we will introduce the targets planned for the EURISOL facility and highlight some of the technical and safety challenges that are being addressed. The EURISOL Radioactive Ion Beam production relies on three 100kW target stations and a 4MW converter target station, and aims at producing orders of magnitude higher intensities of approximately one thousand different radioisotopes currently available, and to give access to new rare isotopes. As an illustrative example of its potential, beam intensities of the order of 10^{13} ^{132}Sn ions per second will be available from EURISOL, providing ideal primary beams for further fragmentation or fusion reactions studies.

Direct High Power ISOL Targets

Classical ISOL targets are operating for more than four decades. In order to open the fission, spallation, and fragmentation reaction channels, the target material is directly exposed to energetic charged particle beams of protons or light ions. This method has proven to be very successful; around 1,000 radioisotope beams of 70 different chemical elements have been produced with driver beams energies ranging from 40 MeV/A to 1.4 GeV/A at ISOLDE-CERN-Geneva, RIBF-Oak Ridge, TRIUMF-Vancouver, and ISIS-Gatchina. The crucial need for chemical purity and the presence of isobars with orders of magnitude more intensity, due to their relative proximity to stability, lead to the development of various types of chemically selective ion-sources, molecular side bands, and active transfer lines.

Today, 100 target-transfer-line-ion-source systems are operated routinely at with both pulsed (1–4 kW) and quasi DC (up to 10–35 kW) driver beams. The main challenge set by the 100 kW EURISOL beam power, is that the evacuation of the energy deposited by the 1 GeV protons through ionization in the target material, while the target materials (some of which are low density and open structure materials or are in the form of oxides with thermal insulating properties) are kept at the highest possible temperature to minimize the diffusion time of the radioisotopes. The target oven is designed to optimize the pumping speed. The EURISOL ion-source and transfer lines are designed to efficiently ionize larger amounts of radioisotopes in the presence of an increased flow of

impurities released by larger amounts of target materials.

The life time of the target, transfer-line, and ion-source system is a key issue that directly impacts on the availability of the facility via the ratio of the time required to change the target-ion-source unit and to tune the beam, versus the radioactive beam operation time (typically a total of 10 days). Today's target-ion-source unit's life time is $1.5 \cdot 10^{19}$ protons when operated in pulsed mode at 1.4 GeV, and reaches $3.2 \cdot 10^{20}$ protons under quasi cw operations with 0.5 GeV protons (EURISOL: $5.4 \cdot 10^{19}$ 1 GeV protons per 100 kW beam day). This, and the need to deliver different ion-beams to several users in parallel, motivated the choice of three independent 100 kW direct target stations.

High temperature sintering, grain growth, and radiation damages induced by the driver beam on the target material, its container and ion source components, are the likely factors limiting the life time of the target and ion-source system. The effects will be increased decay losses as well as the reduction of yields and ion-source efficiency. Four target and ion-source systems were selected in the EURISOL design study in order to benchmark the necessary R&D fields and to validate the necessary engineering and numerical simulations tools.

Heat transfer. With deposited powers of the order of 10 to 60 kW, efficient and novel heat dissipation schemes must be developed. For oxide targets—otherwise known as thermal insulators—this is addressed by the development of new composite materials such as a niobium-foil–aluminum oxide compound. For molten

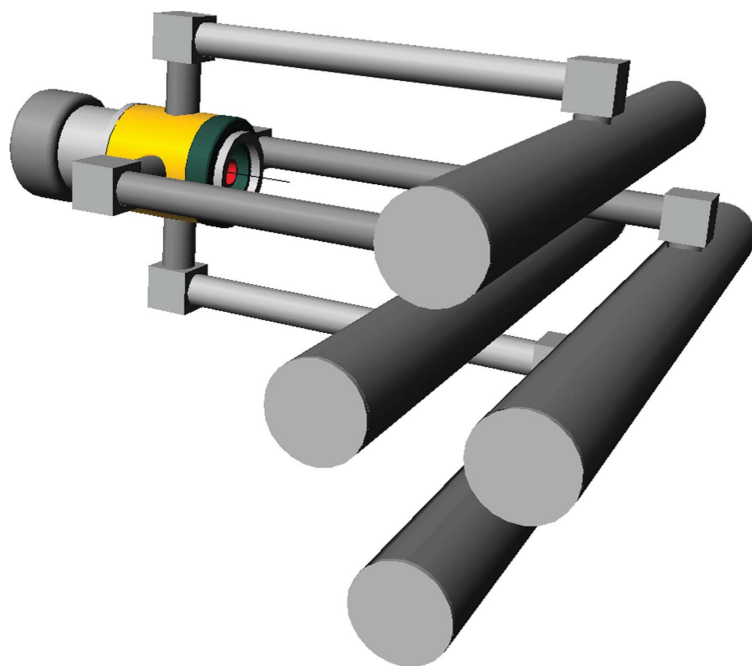

Figure 1. The EURISOL 100 kW multi-body direct target concept, four targets are connected to a single ion-source. The proton beam is sequentially distributed on each target.

metal target units, circulation loops and heat exchangers will handle the heat load, where the release properties rely on the appropriate design of an isotope diffusion chamber with minimal drop size or liquid layer thickness.

Multi-body target. Efficient heat dissipation is achieved at TRIUMF for a primary beam power of 20 to 50 kW. Several compact sub-units of the same type, each accommodating ~25 kW, will successfully address the heat deposited by a 100 kW driver beam (Figure 1). The release properties are influenced by the merging of the neutral atomic streams from the sub units into a single ion source, through short transfer lines. The target life time is slightly affected by the pulsed proton beam time structure inherent to the distribution of the p-beam to each sub unit. To benchmark the release, a dual container target equipped with two

transfer lines and remotely actuated tight valves has been tested with a noble gas ion source at ISOLDE. The measured release reproduces the expected effusion delay originating from a fraction of the isotopes revisiting the second transfer line and target. As it is known for many elements, the

diffusion process is dominating the release. The first results on Ar and Ne radioisotopes are promising.

Radiation induced material damage. The Target Prototypes Irradiation Programme for EURISOL (TARPIPE) is ongoing at Injector 1 at the Paul Scherrer Institute. Samples of metals, carbides and oxides were irradiated in order to reach several displacements per atom (dpa), which corresponds to 3 weeks of target operation at nominal EURISOL parameters. Visual and microscopic observation of the material before and after irradiation will allow assessing sintering and irradiation effects at nominal operation temperatures.

Diffusion. New submicrometric and nanometric target materials are under development, where their stability at high temperature and under intense irradiation is a critical feature. A first milestone has been achieved with the successful development of submicrometric SiC targets (Figure 2), which has produced the highest and most stable yields of exotic Na and Mg isotopes at CERN-ISOLDE.

Ion-sources and effusion. The ion sources tested with one order of magnitude increase of the stable ion current, kept their efficiencies. For the more

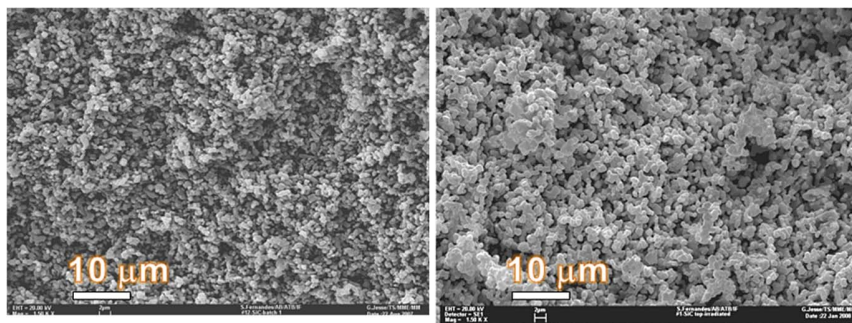

Figure 2. Micrograph of a sub-micrometric SiC target before (left) and after (right) in-beam operation at CERN-ISOLDE.

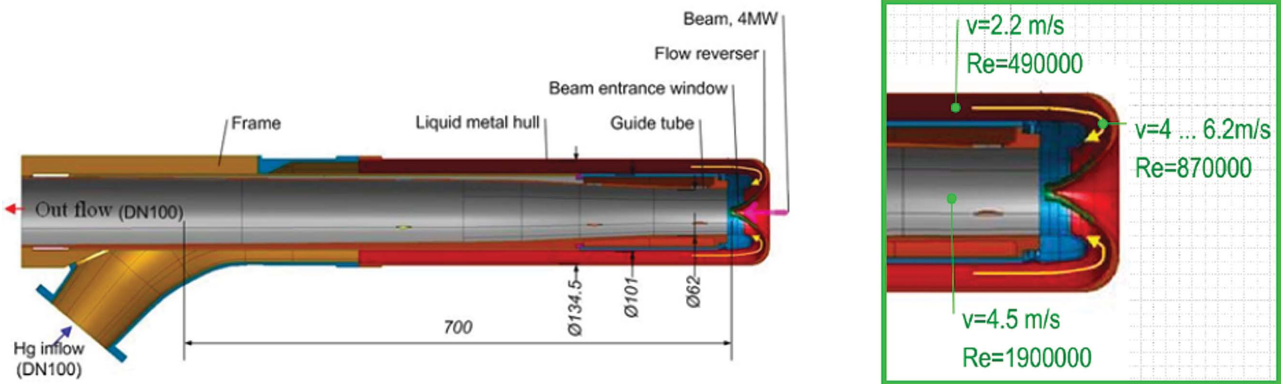

Figure 3. Coaxially Guided Stream Hg-spallation neutron source designed for the 4 Mw target station of the EURISOL facility, the expected Hg-flow velocities are indicated on the detailed view of the 180° turn.

complex target-ion-source systems that have been proposed, the effusion time will increase. Very short lived elements will still require dedicated systems.

Direct target yields. The production cross-sections of the 100 kW target stations are the same as those found at ISOLDE (1 GeV). The yields of neutron rich radioisotope resulting from fission reactions are not very sensitive to the proton energy between 0.5 and 1.4 GeV; however, evaporation is larger with increasing proton beam energy and enhances the production in the n-deficient and deep spallation domains. Light fragments are strongly enhanced with increasing proton energy (i.e., yield increases of several orders of magnitude were measured for light sodium isotopes between 600 MeV and 1.4 GeV at ISOLDE). Within the EURISOL framework, the direct target RIB intensities are expected to be proportional to the driver beam power.

Neutron Converter ISOL Targets

The neutron converter ISOL concept was first proposed by Jerry Nolen and co-workers. In an ISOL converter

system, the neutrons are generated by high energy protons impacting on a high Z material (so-called spallation n-source). The radioisotopes are the fission products of fissile target material positioned close to the neutron source. The “low” temperature converter is also designed to convey the heat resulting from the primary particle’s ionization losses to dedicated heat exchangers. In order to cope with the 2.3 MW power deposited in the spallation target, out of the 4 MW EURISOL proton beam, it has to be made of liquid metal. Two options based on axial or radial molten metal flow directions were investigated. It is interesting to note that, for a given Hg temperature increase (typically 120–180 K), a radial flow allows one order of magnitude higher power density.

Converter with Liquid Metal in Contact with a Window

In the Coaxial Guided Stream (CGS) design, the mercury is kept under pressure and flows within a double walled tube with a proton beam window at one end (Figure 3). The mercury flows toward the proton beam in the outer part of the tube and along the

p-beam in the inner part making a u-turn at the window. By choosing mercury, which is an excellent spallation target and is liquid at room temperature, this liquid metal can transport away a huge amount of heat, and at the same time cool the target walls and the window. The radioactivity induced in the mercury can to some extent be removed, with some of the extracted isotopes having a commercial value.

The energy deposition peaks at approximately 2 cm after the interaction point, reaching 1.9 kW/cm³/MW of beam, and decreases rapidly thereafter. The beam window is enduring must withstand 900 W/cm³/MW of beam. The window parameters were optimized using an iterative process in which the temperature and thermal stress in the window were calculated to be below irradiated materials stress limits. Once the beam window was optimised, the liquid mercury flow inside the target container was tuned to minimise pressure losses while ensuring adequate cooling of the window and preventing vaporization and cavitation in the back-swept surfaces. Eventually, annular blades were inserted along the beam window to

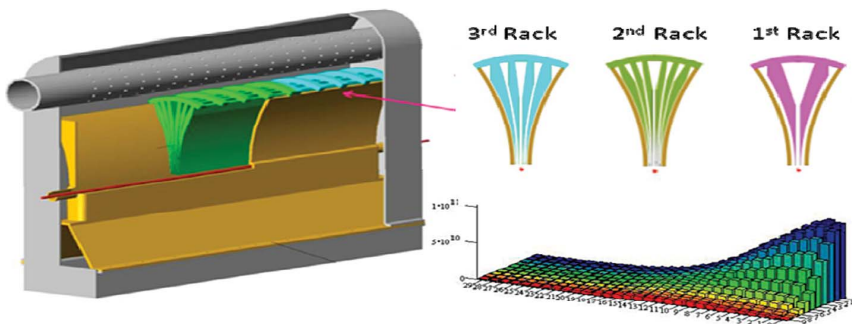

Figure 4. Windowless Metal Transverse Flow (WMTF) spallation neutron source. Three pitch flow-guide racks were designed to match the Hg-flow to the driver beam deposited power density illustrated by the lego plot.

accelerate the flow, increase the local cooling and reduce the pressure drop at the 180-degree turn. With this design, and a bulk pressure of 7.5 bar, the maximum temperature in the beam window is 200°C and the maximum von-Mises stress is 135 MPa. The mercury peak temperature is 180°C and its maximum velocity is 6 m/s at the 180-degree turn, in the channels formed by the flow-guides and the walls.

A Windowless Liquid Metal Converter

The so-called Windowless Transverse Mercury Film (WTMF) target (Figure 4) avoids the technical difficulties related to pressurized beam windows and is advantageous in terms of neutronics. Mercury flowing through the upper tube is guided into a vertical jet by sets of fins. Below the interaction point, the mercury is recovered and pumped to the heat exchanger circuit, where the volatile separator and the mercury reservoir are placed.

The brief exposure of the liquid metal to the proton beam permits control of the temperature increase by setting the local velocities via tuning of the fin pitches to match the beam cooling requirements. The WTMF

target was evaluated for a mercury flow-rate of about 12 l/s; a temperature increase of the mercury of about 117.5 K; a heat deposition density on the beam centre line of 25 kW/cm²; and a total heat deposition of 2.3 MW. The film is split in two regions, a central one (1 cm thickness), receiving the impact of the beam and flowing at high speed, and an external one confining the former (1.5 cm on each side) to reduce high-energy secondary particles

escape and maximize the production of spallation neutrons.

Three different prototypes were tested on an Indium-Gallium-Tin loop at the Institute of Physics and the University of Latvia (IPUL, Riga). The film behavior and flow stability seem a priori compatible with the EURISOL design requirements, although further tests, involving larger mass flows, have to be performed. In order to test the feasibility of the WTMF design, a scale model is being developed and will be tested with mercury.

The beam-target interaction as a free surface facilitates operation over extended periods; a reduction of the target exchange frequency (due to beam window radiation damage) is anticipated. Moreover, the reduced thickness of the film produces a harder neutron spectrum and permits the positioning of actinide fission targets closer to the interaction point. This increases the fission density rates and reduces the higher actinide production, by favoring fission rather than capture reactions.

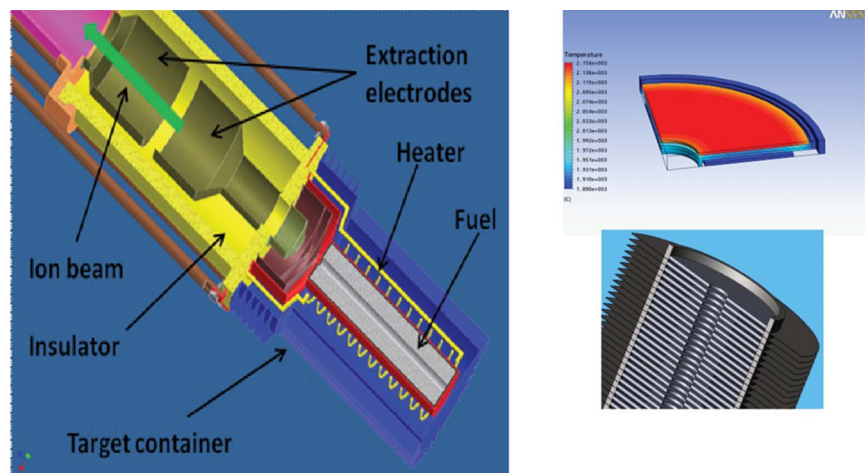

Figure 5. Fission target assembly (left); Details of the finned target, maximizing heat dissipation, and its thermal equilibrium calculation are shown (right).

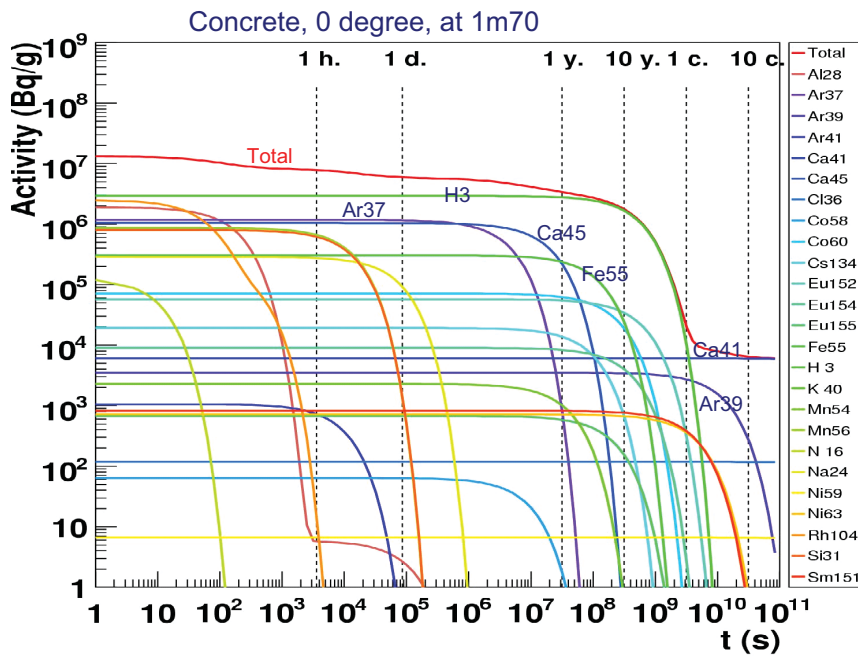

Figure 6. Time evolution of the specific activity of the shielding concrete after forty years of operation. In this simulation, 2.3 MW are deposited in the Hg neutron spallation source, out of the 4 MW average beam power.

Fission Target

EURISOL-DS targets are derived from the concept proposed by the PIAFE (*Projet d'ionisation et d'Accélération de Faisceaux Exotiques*) and MAAF (*Munich Accelerator for Fission Fragments*) projects. Conceptually, a target filled with ^{235}U or other actinide is inserted, through a channel created in the shielding, close to the neutron source at the position of maximum neutron flux. Each target module can be inserted, replaced and serviced by means of remote handling. The shielding around the n-spallation source is a combination of iron and concrete with a total thickness of about 6 meters. The neutron flux is thermalized in order to optimize ^{235}U fission while for other fissionable target materials, like ^{238}U or ^{232}Th , a hard neutron spectrum is required. Up to six vertical channels are foreseen each

containing MAAF-like production systems. Loading and unloading all beam elements, including the fission targets, is accomplished within a mobile transport tube. The assembly is then moved into a hot cell where remote handling of the components will be performed under visual control.

In operation position, all components are inside a double walled vacuum tube embedded in the concrete shielding. A cooling water system is required to evacuate the fission heat of 30 kW that correspond to 10^{15} fissions per second. In view of the radiation levels, vacuum pumps have to be placed after the shielding. In order to evacuate the gases continuously emanating from the fission target during operation, cryo-panels are distributed inside the vacuum tube. The system not only improves the vacuum but also

traps and confines the radioactivity from gaseous elements.

The MAAF fissile material is highly enriched uranium dispersed in the graphite matrix with a ^{235}U -density of 2 g/cm^3 . To host ^{235}U , two graphite types were selected in view of their thermal properties: MKLN (special graphite) and POCO (graphite foam). High density uranium-carbide (UC) pellets containing ^{238}U , enriched with about 2% of ^{235}U , has a total U-density of 12 g/cm^3 . An intensive R&D program to characterize the RIB-yields of high density uranium-carbide has been carried out in collaboration with several European Institutions.

The target assembly is shown in Figure 5. The actinide carbide disks are housed in a graphite primary container, 200 mm long and 35 mm diameter, surrounded by a tantalum container acting as confinement and as heat radiator. This container has a finned structure that increases its effective emissivity and allows the active target volume to remain at the required high temperature of around 2000°C , while the temperature drop is mainly localized across the fins. A central hole of 8 mm diameter links to single ionization ion sources (laser, plasma, ECR) that are under investigation. The fission target has been designed to operate at 100 kV.

Fission target yields. The flexible approach resulting from the multi-fissile targets inspired from the MAAF-PIAFE projects, allows neutron spectra from thermal to hard and the choice of suitable actinides. The isotope production charts are under investigation; the various options yield up to orders of magnitude differences in specific cross-sections (illustrated by the difference of thermal neutrons induced ^{235}U fission vs. hard neutron driven ^{238}U fission). The individual target units are to be designed to handle 10^{15} fission/s for a

^{235}U targets in a thermal neutrons flux. Reduction of the fission rate by one order of magnitude is expected for other actinide targets used with hard neutrons.

The release time is driven by diffusion and effusion. Therefore, the decay losses will be given by the chosen actinide, its isotopic distribution, stoichiometry, mass, and geometry. As a first approximation, in view of the similar actinide masses and target volume involved, the typical release parameters (and decay losses) should be close to those of standard ISOLDE UCx targets.

The ion-sources will be dealing with 3 orders of magnitude higher radioactive beams and higher stable elements streams than today's systems. Further work is required to assess the Multi-MW fission target ionization efficiencies. The ion beams of this target and ion-source multi-systems needs to be merged, a proposition based on an open ECR structure is under investigation, while seemingly promising, its efficiency is not yet determined.

Safety for High Power ISOL Targets

The envisaged EURISOL facility will produce RIBs at intensities 2–3 orders of magnitude higher than existing facilities. A corresponding increase of the radioactive inventory is expected that requires a dedicated safety file containing procedures, hazard evaluation, risk analysis, operational safety that should be in the foreground from the very first design, to the dismantling of the facility including disposal of the radioactive waste. The selection of the production methods, the choice of materials and the design of the facility must be integrated from the start. The safety aspects of the future RIB production targets and transport system, among them, the fissile targets aiming at a few 10^{15} fissions/s, will bear the

highest activity and shall integrate the best safety standards. The new RIB production techniques will be key inputs to the safety approval procedures and will have a major impact on the final cost of the entire facility.

Spallation neutron source. EURISOL relies on a high-energy high-intensity proton accelerator coupled to the high power liquid Hg target. This results in a comparable nuclear installation to the new generation spallation neutrons sources SNS (Oak-Ridge, USA) and J-SNS (J-PARC, Japan).

Fission products. The fissile material RIB production targets will use either uranium or thorium, leading to an in-target thermal fission power comparable to low power research reactors.

Confinement. Radioactive nuclei beams of unprecedented intensities up to 10^{13} ions/s will be extracted, ionized, and post-accelerated up to the energies of 150 MeV/u and distributed over large areas to the experiments. In view of these mobile and quickly transported sources, ensuring the radioprotection of the staff in the experimental hall will be a major challenge. Furthermore, non-ionized gaseous/volatile radioactivity is freely traveling in the beam pipes and vacuum system and must be monitored, controlled, and managed.

Dose rates. Much of the safety work has focused on the Multi-MW target station—the most challenging issue in this context. The characterization of prompt radiation from primary beam components, target-converter, RIB production targets, beam dump, and secondary beam lines is being assessed. The activation of the entire environment including buildings, air, soil, and ground water have been estimated. The prompt and residual dose levels are crucial inputs to the dimensioning of the buildings and appropriate shielding structures, for defining the maintenance

procedures and accessibility levels, and for preparing dismantling and decommissioning strategy. As an example, the residual specific activity of the concrete shielding is shown in Figure 6.

Radioactive waste disposal. The handling and disposal of the radioactive production targets (e.g. UCx, ThCx), the liquid Hg converter target and its auxiliary systems is not yet studied. Our estimates show that the induced radioactivity of the Multi-MW target station reaches approximately 10^9 GBq. This implies that the radioactivity handling and the prevention of release accidents should be comparable to the nuclear power industry. At the end of EURISOL operations, the irradiated liquid mercury (~20 tons) has to be treated as highly radioactive waste. The only appropriate final disposal form for this radiotoxic and toxic type of waste is solidification. Therefore, we launched both theoretical and experimental dedicated studies on solidification of mercury, aimed at the selection of an adequate synthesis and of a matrix suited for its final disposal.

Radioactive gases. 10^{15} fissions/s also yield sizable amounts of volatile radioactive species that have to be confined. For this purpose, the concept of a cryo-trap system placed between the production target and the experimental area has been proposed, designed and tested to freeze gaseous radioactivity as close to its origin as possible. The studies converged on the design of a compact cryo-trap operated with cold helium gas at a saturation temperature around 18 K, with a volatile radioactivity retention capability of 99.98%. These design goals have been experimentally verified with two different prototype cryo-traps. One of these solutions will be implemented in the beam line design of EURISOL.

Alpha emitters. Direct irradiation of actinide targets with high-energy, high-intensity protons results in the production of volatile long-lived alpha emitters. The most obvious is radon that itself conveys little radiological hazard, but decays into products (the so-called radon progeny) of considerable radio-toxicities such as ^{210}Po . The dose per unit intake of activity of alpha-particle emitters, is approximately 1,000 times that of beta/gamma-emitting radio-nuclides. The installation should be equipped with dedicated monitoring systems and procedures to keep under control the alpha radioactivity levels.

Critical group. The critical group exposure via complex pathways, including the air, water, and food chain both in normal operation and accidental situations must be investigated. For this purpose, a dedicated EURISOL Toolkit was created, which gathers the relevant information and source data as well as other information or methods already validated, accepted, and recommended by national and international regulatory bodies. This toolkit includes models for assessing the health and environmental impact of nuclear facilities that are suitable for research nuclear reactors and high-power high-energy particle accelerators. The EURISOL Toolkit is being tested and will be applied for a selected case study characteristic for the EURISOL Multi-MW target station, leading to the environmental impact assessment both in normal operation condition as well as in accidental situations.

Eventually, we would like to stress that safety and radioprotection aspects of the future high power ISOL targets must be addressed at the very conceptual stage of the design studies. The EURISOL design study is a good example of this approach.

Discussion and Conclusion

Development and engineering.

New target arrangements or materials aiming at improved heat dissipation or conduction (ISOLDE, TRIUMF), long-term stability (high density UC, PNPI Gatchina) or release properties SiC (ISOLDE) were successfully developed. Synthesis of new UCx materials with improved mechanical properties are under development at INFN-LNL and will be evaluated for RIB production both at ISOLDE and within the SPES project. Innovative solutions were proposed for windowless neutron spallation sources, modular actinide targets, atomic beam merging in ion-sources, and radioactive ion-beam merging in open ECRs that are all mandatory assets for future high intensity RIB facilities.

Figure of Merit of the EURISOL Facility. The potential of the EURISOL facility in producing 1,000 different radio-isotopes, with two to three orders of magnitude yield increase, is within reach. The cross-sections are well known; the decay losses were extensively measured and assessed; the ion-source efficiencies are confirmed or improved via developments of Resonant Ionization Laser ion-source based on solid state lasers; and improvement in release time were obtained and are still to be expected with increasing experience in the engineering of new materials. New reaction channels become de facto available; in dedicated modular units coupled to the neutron spallation source with the n,x reactions such as those explored at Louvain-La-Neuve, or being developed at the future SARAF accelerator at Soreq NRC.

Safety. Safety integration from the start hints to the need of innovative and flexible solutions in matters of safety. While EURISOL has similarities to high-power spallation n-sources and to

small research reactors, the use of high temperature pyrophoric actinide carbide targets, the presence of alpha emitters and the distribution over extended buildings of intense radioactive beams and sources of all chemical natures, is very specific and requires dedicated technical standards that will have to be applied under utmost reliable safety rules and procedures.

The ambitious targetry goals set by the EURISOL study group [2] are being effectively addressed within the EURISOL-Design Study; this global targetry and safety effort involved close to 200 scientists and technicians across 40 institutes from 22 countries. Their crucial contributions in delivering innovative solutions and relevant technical developments are hereby acknowledged. Furthermore, a wide dissemination of information took place, its apex being the training of many young scientists in the most effective manner, namely via the simulation and realizations of prototypes tested in realistic conditions at operational RIB facilities.

YACINE KADI, JACQUES LETTRY, AND
MATS LINDROOS
CERN

DANAS RIDIKAS
CEA

THIERRY STORA
CERN

LUIGI TECCHIO
INFN

References

1. <http://www.eurisol.org> and references therein.
2. "The EURISOL report," Ed. J. Cornell, GANIL, Caen, 2003, European commission contract No. HPRI-CT-1999-500001.