

Motions of a Cylinder in Waves

by

Georgina Maldonado-Aguirre

SUBMITTED TO THE DEPARTMENT OF
MECHANICAL ENGINEERING
IN PARTIAL FULFILLMENT OF
THE REQUIREMENTS FOR
THE DEGREE OF

BACHELOR OF SCIENCE

at the

MASSACHUSETTS INSTITUTE OF TECHNOLOGY

June 1991

© Massachusetts Institute of Technology 1991

Signature of
Author _____

Department of Mechanical Engineering

May 10 1991

Certified by _____

Paul Sclavounos

Department of Ocean Engineering

Thesis Supervisor

Accepted by _____

MASSACHUSETTS INSTITUTE
OF TECHNOLOGY

Professor Peter Griffith

JUN 24 1991 Chairperson, Department Committee

LIBRARIES

ARCHIVES

Motions of a Cylinder in Waves

by

Georgina Maldonado-Aguirre

Submitted to the Department of Mechanical Engineering
on May 10, 1991 in partial fulfillment of the
requirements for the Degree of Bachelor of Science in
Mechanical Engineering

ABSTRACT

An experimental study was carried out to determine the dependence of cylinder motion in waves to the wave frequency and the wave amplitude. There were seven frequencies tested ranging from 1.1Hz to 1.7Hz. There were a variety of amplitudes tested ranging from half and inch to two inches. All of the testing was done in the MIT towing tank. The cylinder had a one foot diameter and a 3.5ft draft which displaced 170lbm of water.

The observed velocities were compared against predicted velocities. The predicted velocities of the cylinder were determined by dynamically developing the velocity dependence on the damping force, the excitation force, and the drag force.

The observed velocities had a higher dependence on the frequency in comparison to the predicted values. The observed velocities had no detectable dependence on the amplitude.

Thesis Supervisor: Paul Sclavounos

Title: Professor of Ocean Engineering

Contents

1	Background	5
2	Experimental Set-Up	5
2.1	Construction of Cylinder	5
2.2	The Testing Tank	9
3	Theory	11
3.1	Drift Motion	11
3.2	Surface Wave Theory	13
3.3	Drag Force	16
4	Procedure	18
5	Description of Experimental Results	19
5.1	Comparison to Theory	19
6	Conclusion	25
7	Appendix A:Graphs of all Recorded Data	26
8	Appendix B: Towing Tank Characteristics	37
8.1	Reflection Coefficient	37
8.2	Relation Between Wavelength and Frequency	37

List of Figures

1	Schematic of Cylinder Assembly	8
2	Schematic of Wave Tank	9
3	Mass Dash-pot System	12
4	Free Body Diagram	12
5	Steady State Velocity Streamlines Around a Cylinder	14
6	Progressive Waves in Finite Depth	16
7	Excitation and Damping Forces Used Predictions	17
8	Distance vs. Time plots for Two Amplitudes at each Frequency . . .	20
9	Observed Velocities vs. Amplitude	20
10	Average Velocities and Observed Velocities vs. Frequency	21
11	Equations and Graph Relating the Average Velocities to Frequencies	23
12	Predicted Values and Average Observed Values	23

1 Background

There are many needs for the accurate motion prediction of bodies in oceans. In the arctic the prediction of iceberg motion and velocity will enable safer travel through that area. In the North Sea the prediction of motion and velocities of an offshore structure will enable safer production and transportation of crude oil. The complex interaction between a drifting body and the incident waves is still not fully understood.

This study measures the steady velocity reached by a cylinder due to wave excitation. The testing was done by free floating cylinder to incident waves and observing its motions. A total of seven frequencies were tested, since it was only intended to test the first peak and decline in the velocities predicted by the program. The frequencies tested were low and the amplitudes tested were small compared to the draft of the cylinder. The frequency of the wave excitation was strictly controlled while the amplitude of the wave excitation was measured, along with the velocity of the cylinder drifting down the tank.

2 Experimental Set-Up

2.1 Construction of Cylinder

The cylinder was constructed with several objectives in mind. The cylinder's diameter had to be much larger than the amplitude of the waves which the wave tank could create. The diameter of the cylinder had to be small enough so that the tank could essentially model the ocean. In addition the diameter had to be large enough so that the small amplitude waves would not greatly disturb the center of flotation and topple it over. The cylinder's vertical axis of flotation had to be perpendicular to the undisturbed water surface.

The diameter of the cylinder which was one foot. The average width of the wave tank was 8.5ft. It was anticipated that this diameter would disturb the incident waves, yet not cause a disturbance to be reflected from the walls of the tank. The draft of the cylinder was 3.5ft. The average depth of the tank was 4ft. And the wave amplitude which the wave tank can consistently produce without the crest breaking is about 2.5inches. Another consideration which was taken into account was the possibility of flow separation at the bottom of the tank around the cylinder bottom. Therefore, the cylinder had to float sufficiently above the tank floor so that the flow separation would not create forces around the bottom of the cylinder. It was decided that the cylinder would float at least six inches above the tank floor. A distance greater than six inches would have been acceptable but not highly desirable. In addition, the cylinder depth was to be infinite when compared to the wave amplitude.

A pipe one foot in diameter (PVC-40) was purchased. It was cut to 4.3 ft so that there would be close to one foot floating above water. This was done to insure the cylinder would be given enough room to oscillate back and forth with no water accidentally being added to the mass of the cylinder.

The inner diameter was 11 inches. Since the cylinder was hollow, a method of ballasting needed to be devised. Several methods of ballasting which were tried, and several considerations were taken into account while evaluating the ballasting procedure. One was that the cylinder would displace 170lbm of water with a 3.5ft draft, and therefore would cause problems when taking it in and out of the tank. In addition, the cylinder had to float vertically every time. This meant that the mass had to be equally distributed about the z-axis (see Fig. 1). The ballasting method had to be fairly simple and quick so as to efficiently use the time in lab. Once the objectives had been established methods were developed and compared.

The only way of ballasting the cylinder was to make it weigh as much as the water it was displacing. Two methods were considered for placing the mass inside the cylinder. The first method involved the use of sand bags. This method seemed very promising since it was anticipated that the sand bags would closely follow the

shape of the cylinder. This, however, was not the case. The sand bags left air holes which caused the cylinder to float at an a different angle every time it was reballasted. The second method, the method used, consisted of forming blocks of cement and piling circular weights. Two cement blocks which narrowly fit inside the cylinder were formed. The cement blocks, each had a hole in the middle where a rod could be secured. After the rod was secured inside the cement blocks circular weights were piled on top of them. The rod in the center offered a guide for the weights and assured that the weights mass was evenly distributed. The actual weight of the total mass of the cylinder was never determined. However, the water displacement was determined to be 170lbm. Once the draft reached the value desired, the addition of the weights was terminated. A schematic of the cylinder along with the cement blocks and the weights are shown in Fig 1.

The characteristics of the cylinder are as follows:

outer diameter	12 5/8 in
inner diameter	11 3/4 in
average draft	3.5 ft
total length	4.3 ft
weight of water displacement	170lbm

Table 1

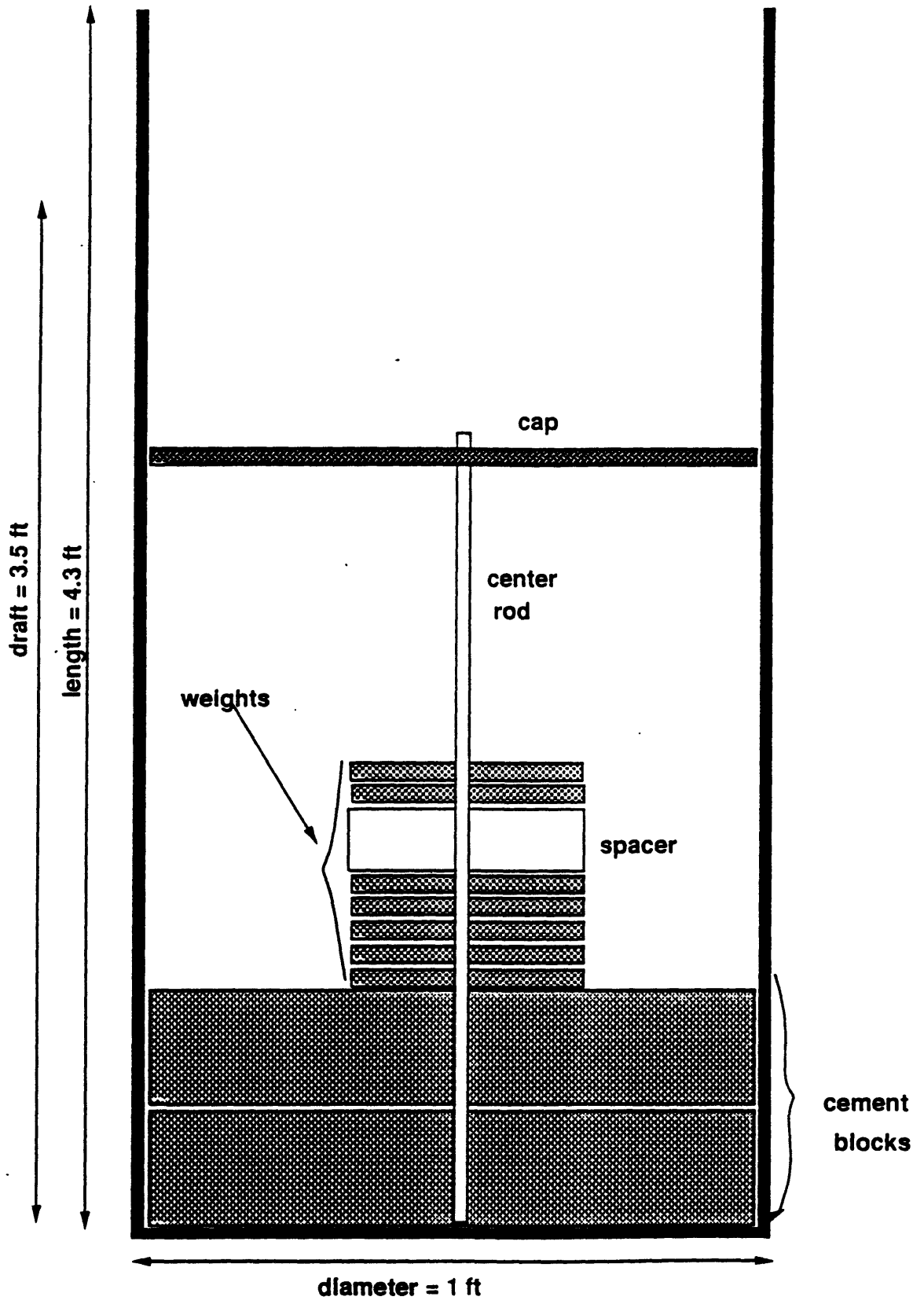

Figure 1: Schematic of Cylinder Assembly

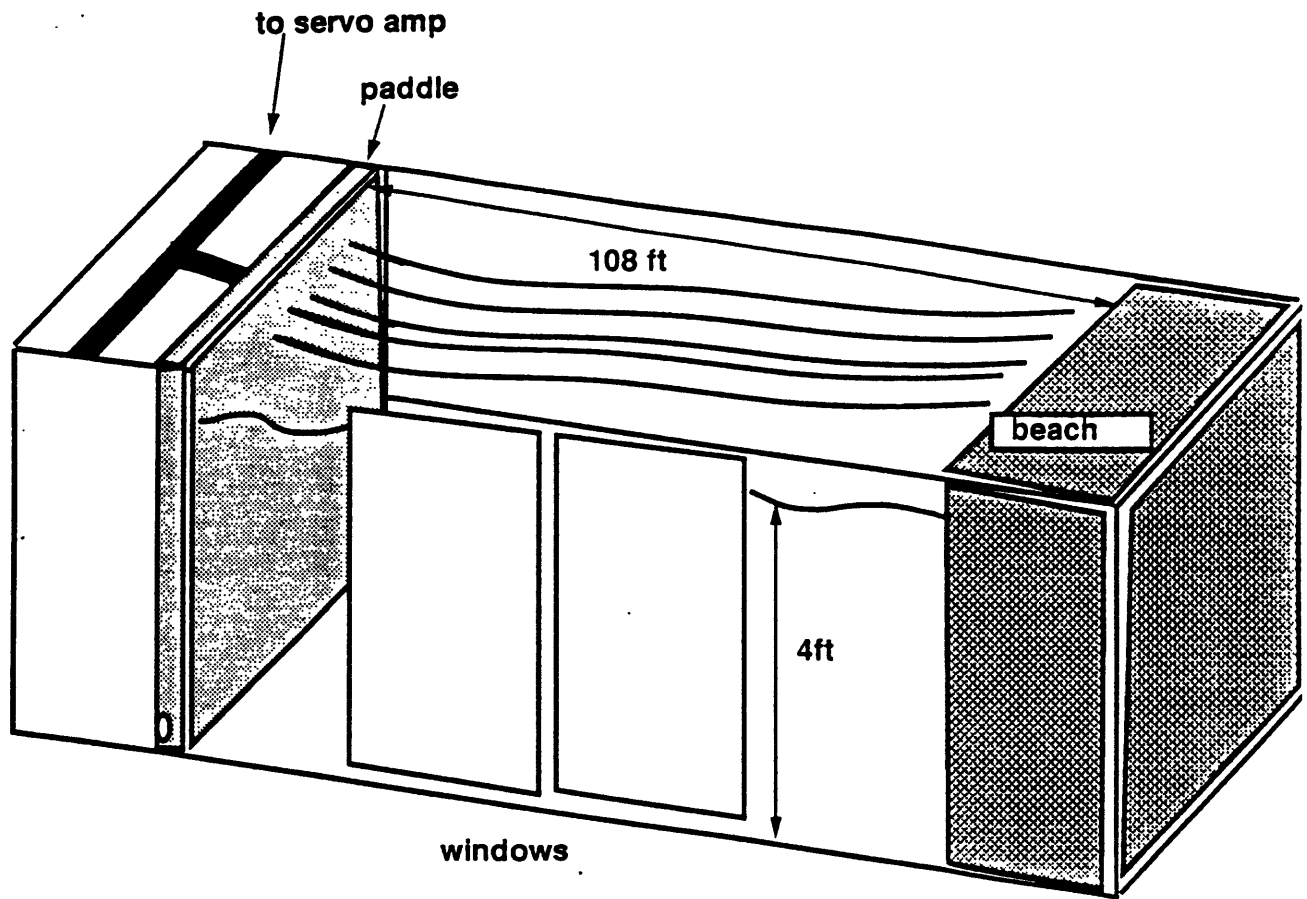

Figure 2: Schematic of Wave Tank

2.2 The Testing Tank

All of the testing was done in the MIT towing tank. A schematic of the tank is shown in Fig 2. The characteristics of the tank are as follows:

distance to beach	108 ft
average depth	4 ft
width	8.5 ft
reflection coefficient	0.132

Table 2

The tank creates waves by motions of a paddle. The paddle motions corresponded to dial settings, although the only parameter which was strictly controlled

by the controls was the frequency of the waves. The frequencies tested varied from 1.1Hz to 1.7Hz. The accuracy of the frequency of the paddle decreased for higher values. Since it was intended to test the frequencies around 1.4, a top frequency of 1.7 was determined to occupy a sufficient range. The amplitude of the waves could only be set to differences of big amplitudes and small amplitudes. However, it was not possible to accurately set the amplitude of the waves and as a result they were also measured. A 2.5 inch amplitude was the highest amplitude measured due to the waves breaking, becoming three dimensional, at higher settings. Because of this restriction, it was much easier to test the velocity's dependence on wave frequencies.

3 Theory

3.1 Drift Motion

The motion of a body in water can be paralleled to a mass dash-pot system as illustrated in Fig 1, and the force equation can be derived from the free body diagram in Fig 2. There is no spring in this system due to the fact that the cylinder is not moored, and therefore there are no restoring effects. There is however drag induced by the resistance of the water to let the cylinder move. Drag force is proportional to the velocity squared, as can be seen in the displacement equation (Eq. 1). The motions can be expressed in terms of the displacement and its derivatives by

$$\ddot{x}m + D + \dot{x}B = F \quad (1)$$

The intention of this study was to measure the reached steady velocity which implies that the acceleration would have neared zero and therefore the second derivative term can be eliminated. The equation relating the velocity to the excitation force and the damping force is

$$D + B\dot{x} = F \quad (2)$$

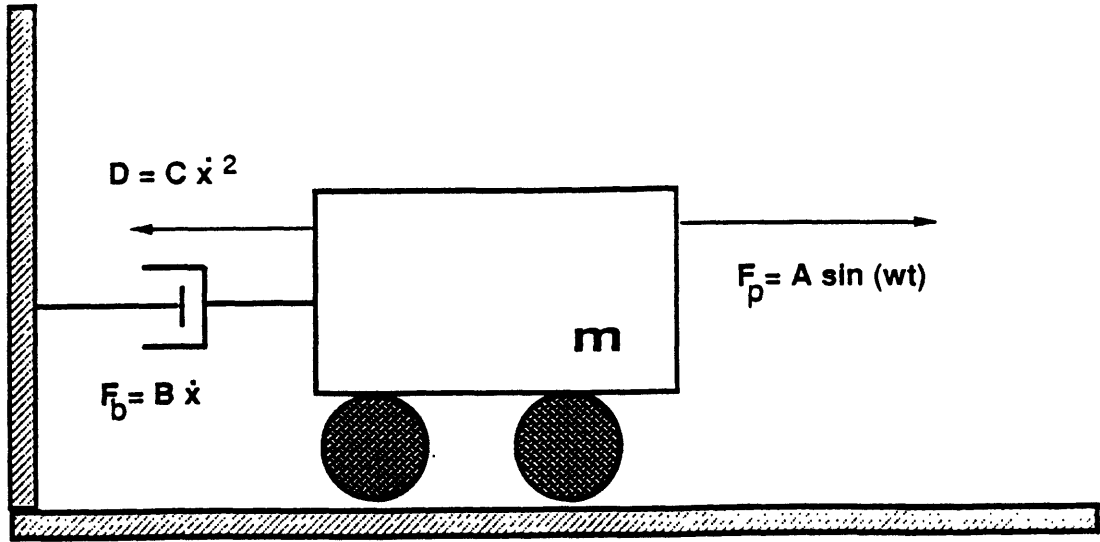

Figure 3: Mass Dash-pot System

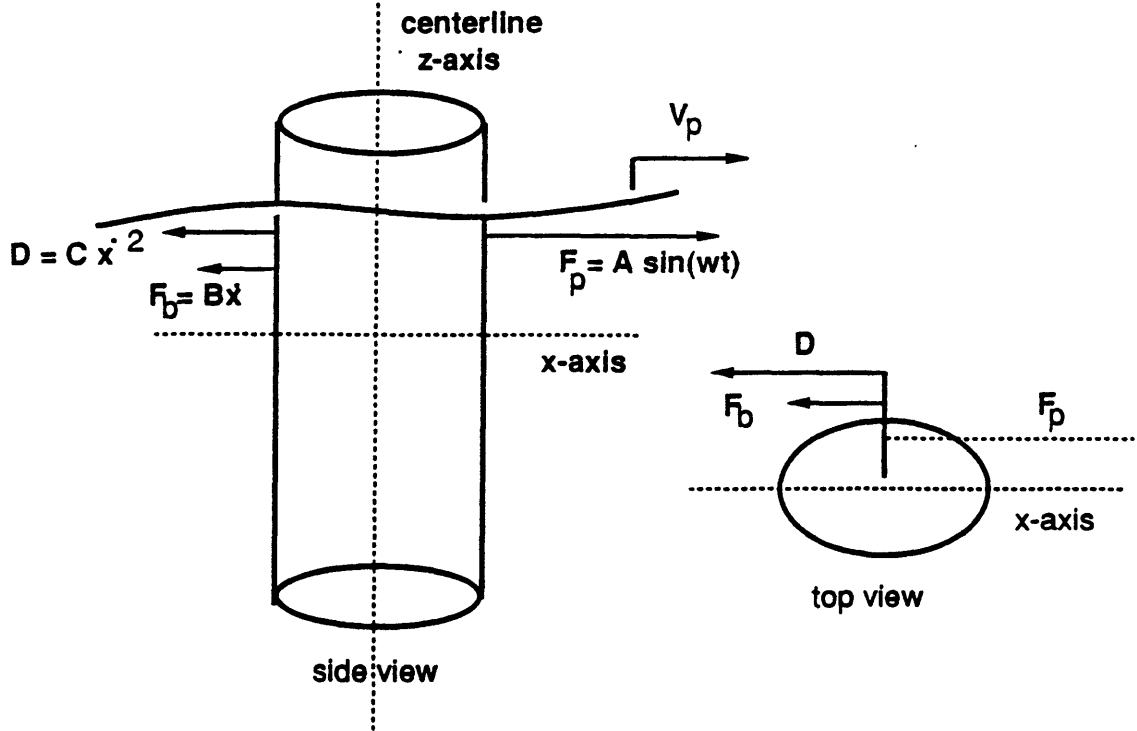

Figure 4: Free Body Diagram

3.2 Surface Wave Theory

This simple dynamics model can be viewed in terms of hydrodynamics. The velocity \dot{x} represents the velocity U in the x-direction. The velocity potential accounts for the velocity in six degrees of freedom and is expressed by

$$\phi = U_i \phi_i : i = 1 \dots 6 \quad (3)$$

It was assumed that the flow around the cylinder was laminar and therefore could be represented by streamlines symmetric about its x-axis (see Fig 6) and around its perimeter. The velocity potential can be expressed by a Taylor series expansion as

$$\phi = \phi^1 + \phi^2 + \phi^3 \dots \quad (4)$$

The first order term of this equation represents the velocity potential in a steady stream; however, this is not what is being represented. It is the second order velocity potential which represents the motion of a cylinder due to waves, sinusoidal excitation. The relationship of the velocity potential to the streamline velocities will better explain the motions dependence on flow.

Along any streamline Bernoulli's equation for steady flow states that

$$P = -\frac{1}{2}\rho V^2 + \rho g z + \frac{\partial \phi}{\partial t} \quad (5)$$

where V represents the rate of change of the path of a fluid particle. This velocity represents only three degrees of freedom u (surge), v (sway), and w (heave). And are related to V by

$$V^2 = u^2 + v^2 + w^2 \quad (6)$$

This velocity in Bernoulli's equation can be related to the velocity potential by Euler's equation

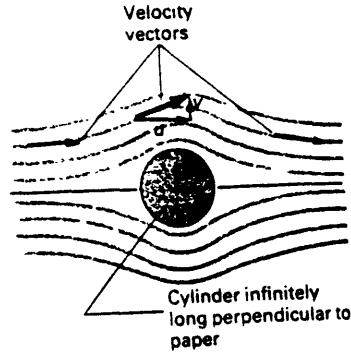

Figure 5: Steady State Velocity Streamlines Around a Cylinder

$$V = \nabla\phi \quad (7)$$

The velocity potential represents the velocity of the streamlines around the cylinder, and using Bernoulli's equation, the pressure distribution around the cylinder can be obtained. For a steady state flow, the streamlines would be symmetrical about the x-axis and would not cause a pressure gradient in any direction. It takes the introduction of unsteady state flow, sinusoidal flow, to form net pressure gradients around the cylinder. In sinusoidal the stream line representation would not be modeled by Fig. 6. The streamlines that form around a cylinder due to wave excitation do develop a pressure gradient, and therefore create forces which push the cylinder in the direction of the least pressure.

The change in the intensity of the velocity potential caused by the sinusoidal change in the free-surface elevation causes pressure difference about the y-axis. The change in elevation, η , when substituted into Bernoulli's equation, gives the relationship between the velocity potential and the surface elevation.

$$\eta = -\frac{1}{g}\left(\frac{\partial\phi}{\partial t} + \frac{1}{2}\nabla\phi\nabla\phi\right) \quad (8)$$

Here the time change in surface elevation is the horizontal change in the velocity potential.

$$\frac{\partial \eta}{\partial t} = \frac{\partial \phi}{\partial y} \quad (9)$$

The Navier-Stokes Slow Drift Theory predicts that the velocity potential for finite depth is

$$\phi = \frac{gA}{\omega} \frac{\cosh k(y+h)}{\cosh kh} \sin(kx - \omega t) \quad (10)$$

The velocity potential can be seen in Fig. 6, Velocity Field of A Plane Progressive Wave. In this figure the phase velocities and the fluid velocity vectors are to the same scale. It can be seen from Fig. 7 that the fluid velocity, V , is not steady, and therefore in accordance with Bernoulli's equation, the pressure due to changing fluid velocity will also change. The cylinder will be essentially pushed by the higher pressure towards the lower pressure. As shown in the well known relation

$$F = \int P dx. \quad (11)$$

From this relation, in the forcing function is

$$F = \frac{1}{2} \frac{A^2}{\omega^4} \frac{\cosh k(y+h)}{\cosh kh} \cos(kx - \omega t) \quad (12)$$

The damping force was found in by a similar derivation.

Both the excitation force and the damping force were predicted by the program, this relation is illustrated if Fig 7. The values expressed by this figure are in SI units. A prediction of the velocity of the cylinder is also seen in this figure. The velocity expressed only takes the force due to pressure change and the damping force. The equation used for this velocity is

$$\dot{x} = \frac{F}{B} \quad (13)$$

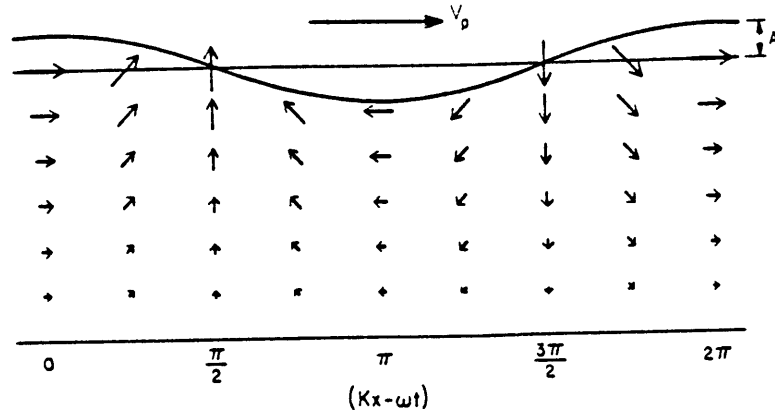

Figure 6: Progressive Waves in Finite Depth

3.3 Drag Force

The drag force, D , in Eq. 1 can be expressed in terms of the cylinder velocity by

$$D = \frac{1}{2} \rho T C_d \dot{x}^2 = C_d \dot{x}^2 \quad (14)$$

where ρ is the density of water, T is the draft of the cylinder, d is the diameter of the cylinder and C_d is the drag coefficient. The value of the drag coefficient was arrived at by narrowing it down to a range of possibilities. The range was to be greater than 0.4 and less than one, since a plate perpendicular to a flow has a drag coefficient of one and a hemispherical cup in laminar flow has a drag coefficient of 0.4.

The velocity of the cylinder can now be determined by substituting the appropriate values for the drag, the damping, and the excitation force in EQ. 1. This leaves the a second order polynomial which can be solved using the quadratic equation.

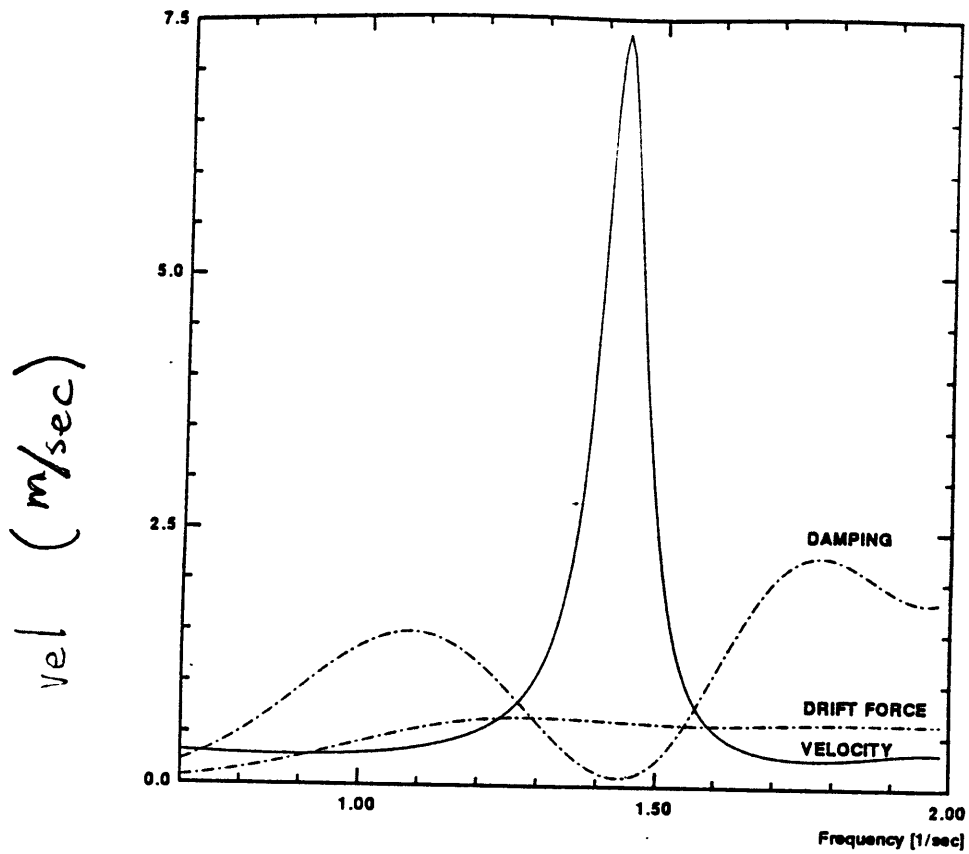

Figure 7: Excitation and Damping Forces Used Predictions

$$C\dot{x}^2 + B\dot{x} - F = 0 \quad (15)$$

The values for the damping force and the excitation force can be read off of Fig 7. Values predicted for the velocity at different drag coefficients are listed in Table 3.

freq	C_d		
	0.5	0.7	0.9
1.1	1.49	1.28	1.14
1.2	1.89	1.49	1.32
1.4	1.81	1.54	1.37
1.5	1.87	1.51	1.34
1.6	1.75	1.57	1.39
1.7	1.81	1.33	1.19

Table 3

4 Procedure

The measurements consisted of recording the distance traveled by the cylinder down the tank and the time it took to travel that distance. The distance between time measurements was predetermined and marked on the side of the tank. The time was measured by visually determining when the center of the cylinder passed each mark. Since the velocity of the cylinder was small, it was determined that this method of recording was sufficiently accurate.

The cylinder was excited by sending waves produced by the wave maker down the tank. The wave frequency was predetermined and the amplitude was measured. The amplitude of the waves was determined by an adjustment of the potentiometer and a physical measurement of the difference between the peaks and the trough. The recorded amplitude is the average of the experienced amplitudes since it was observed that the amplitude generation was not constant.

The cylinder was allowed to travel a minimum of eighteen feet, unless it stopped or hit a wall. It was hard to get the cylinder to travel in a straight line, especially for high frequencies. For all frequencies the motion between walls was recorded. The distance traveled between walls was used to determine the validity of the point. The distance over time for those intervals where the motion between walls was over one foot were discarded. High frequencies had to be tried several times before usable data was collected. It was not certain why the cylinder acted in this way for high frequencies, although it was suspected that the waves produced at high frequencies were not parallel with the wave paddle.

Although the distance to the beach was 105ft the cylinder was allowed to travel a maximum of thirty feet. This maximum was chosen due to the reflection factor being .3. In addition, the walls of the tank were not smooth. It was suspected that the waves after thirty feet had been subjected to three slightly different tank widths, and therefore the squareness of the waves were probably effected. The three slightly different tank widths were caused by the seals which held the water in at the two

windows of the tank.

5 Description of Experimental Results

A total of seven frequencies were tested. The velocity of the cylinder was taken to be the slope of the square fit curve for distance vs. time. The distance vs. time graphs along with the best fit lines for each tested frequency and amplitude are shown Appendix A. It should be noted that these best fit curves do not represent the velocity. The average velocity was determined by taking the average of those distance intervals in which the cylinder did not deviate more than one foot from a straight path down the tank. In some instances the whole run was discarded since the cylinder was literally going from wall to wall. In most of the discarded runs the cylinder would travel rapidly between walls and slowly down the tank or at rapidly between walls and slowly down the tank.

The average velocities represented by slopes of distance vs time can be compared in Fig.8 which shows two slopes one high and one low. There seemed to be little dependence on the amplitude of the waves, as shown in Fig 9. The observed velocities for each frequency occupied a definite range with the change in amplitude as shown in Fig. 10. In addition, a greater dependence of the velocity on the change in frequency exists.

The experimental results can be separated into two equations: one for the frequencies below 1.4Hz and one for the frequencies above 1.5Hz. These equations and the curves are shown in Fig 11. The slopes of different amplitudes for the same frequency occupy a definite range. The average velocity of this range is an accurate representation of the final steady velocity of the cylinder at that frequency.

5.1 Comparison to Theory

The observed velocities do not follow the slight increase then plateau of the predicted values. However, the observed results exaggerate the change in velocity with

Slopes for all tested frequencies

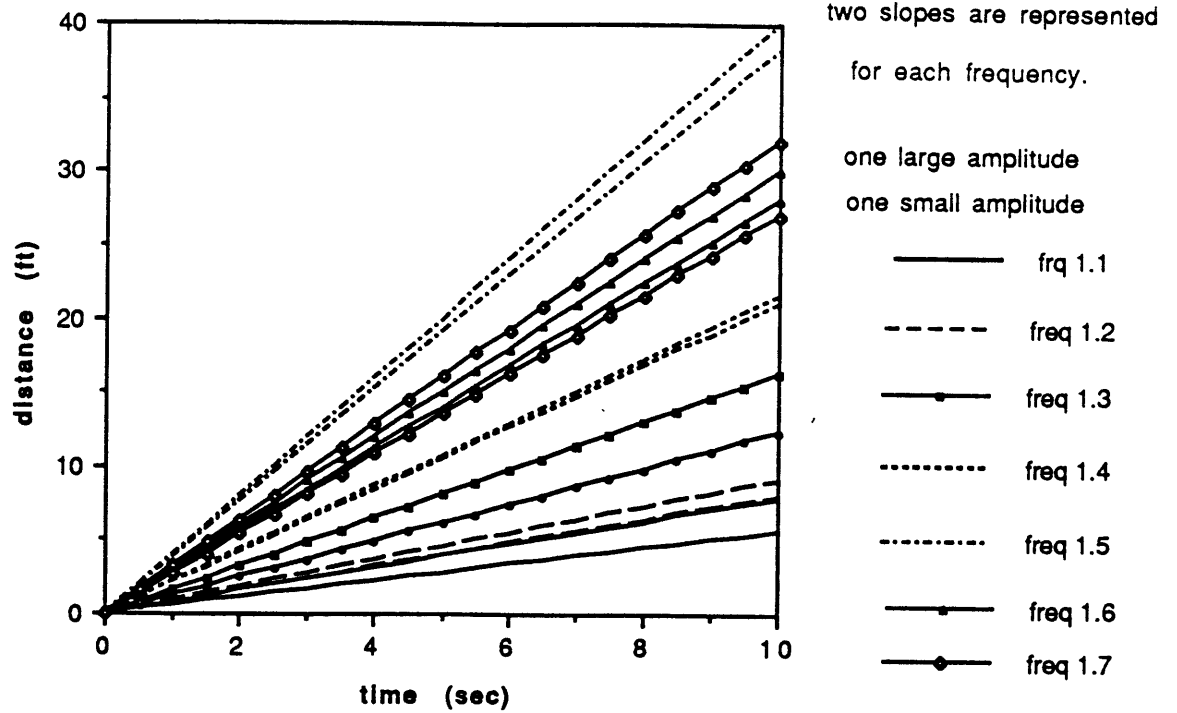

Figure 8: Distance vs. Time plots for Two Amplitudes at each Frequency

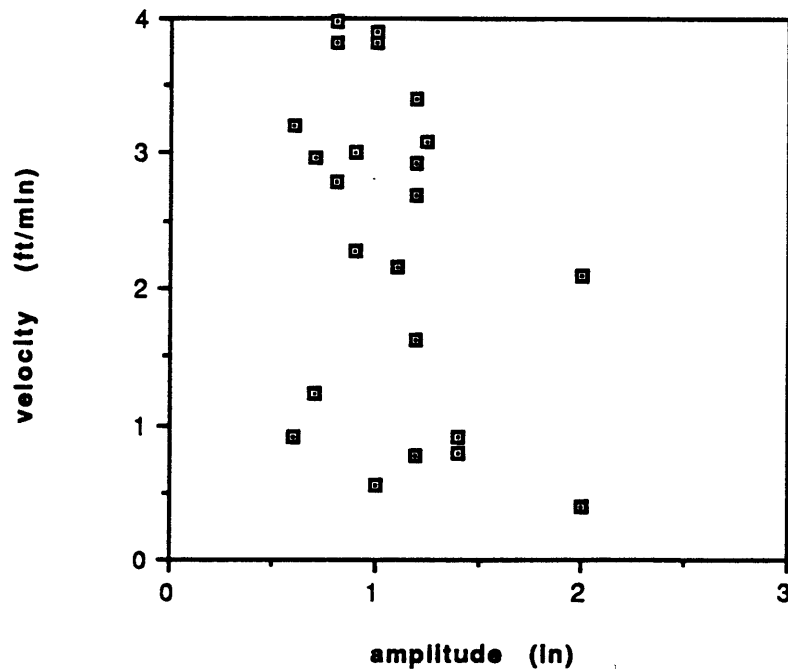

Figure 9: Observed Velocities vs. Amplitude

Averaging of Velocities

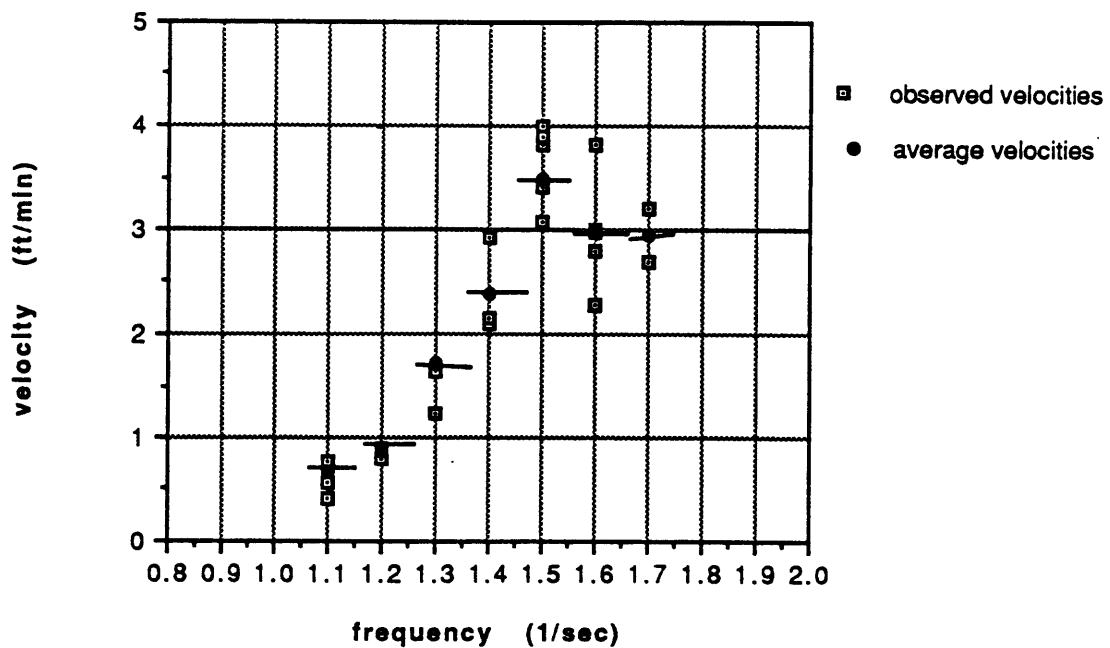
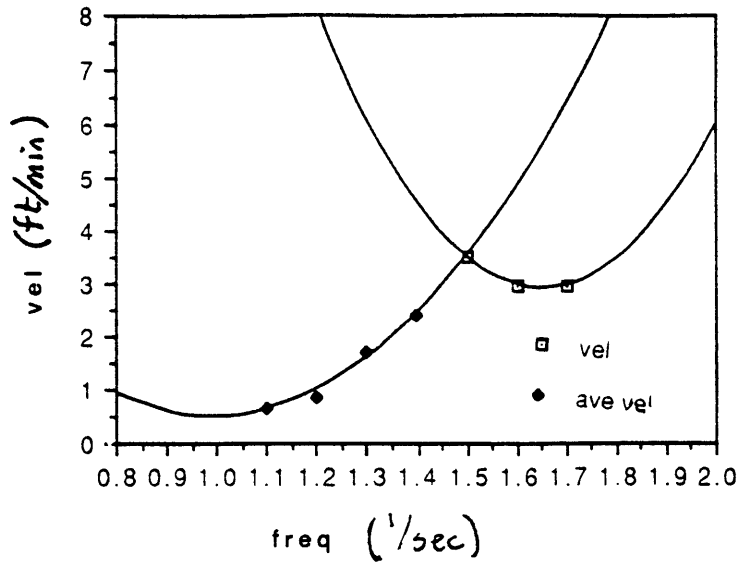

Figure 10: Average Velocities and Observed Velocities vs. Frequency

the change in frequency, which is represented in the predicted values. The observed results seemed to be much more dependent on the frequency in comparison to the predicted results which were somewhat dependent. This comparison is shown in Fig 10.

The results do not plateau at the predicted frequency of 1.3Hz. Instead the observed results keep their rapid increase up till frequency 1.5Hz where the velocity was measured at 3.5ft/min. One possible explanation for this is that the theory does not take into account all the forces present. Since the system equilibrium stage can be easily disturbed, any random force present can cause unpredicted results. One of these forces could be caused by a presence of irrotational flow at higher frequencies which produce higher wave velocity and a greater tendency for the cylinder to travel in the wave direction. Another possible explanation is in the path of the cylinder. As the cylinder as it went down stream it was difficult to get it to go in follow a straight path. The velocities chosen for comparison were those with the nearest straight path. However, due to the difficulty in achieving this path, the velocities observed of usable runs was small and therefore may be an inaccurate representation.



$$y = 72.650 - 84.350x + 25.500x^2$$

$$y = 12.112 - 23.365x + 11.750x^2$$

Figure 11: Equations and Graph Relating the Average Velocities to Frequencies

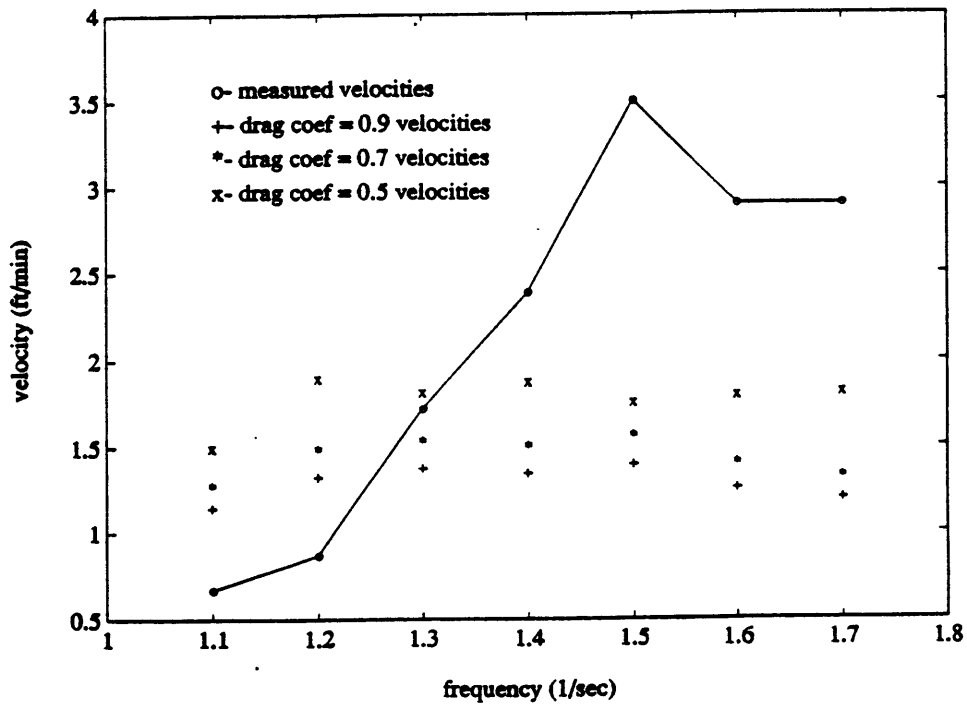

Figure 12: Predicted Values and Average Observed Values

frequency	amplitude (in)	velocity	freq * amp	amp pot sett
1.100	1.000	0.560	1.100	0.600
1.100	1.200	0.780	1.320	0.800
1.100	2.000	0.400	2.200	4.000
1.200	1.400	0.800	1.680	0.600
1.200	0.600	0.910	0.720	0.400
1.200	1.400	0.910	1.680	0.600
1.300	0.700	1.230	0.910	0.600
1.300	1.200	1.630	1.560	1.000
1.400	1.200	2.930	1.680	0.600
1.400	2.000	2.100	2.800	1.000
1.400	1.100	2.150	1.540	0.800
1.500	0.800	3.820	1.200	0.600
1.500	1.000	3.910	1.500	0.900
1.500	1.200	3.400	1.800	0.800
1.500	0.800	3.990	1.200	0.600
1.500	1.250	3.080	1.875	0.850
1.600	0.800	2.800	1.280	0.600
1.600	0.900	2.280	1.440	0.700
1.600	0.700	2.970	1.120	0.500
1.600	0.900	3.000	1.440	0.700
1.600	1.000	3.820	1.600	0.800
1.700	1.200	2.700	2.040	0.600
1.700	0.600	3.210	1.020	0.400

Table 4:Recorded Velocities and Frequencies

freq	ave vel	freq * amp
1.100	0.670	0.737
1.200	0.870	1.044
1.300	1.720	2.236
1.400	2.390	3.346
1.500	3.500	5.250
1.600	2.970	4.750
1.700	2.950	5.020

Table 5:Average Velocities with Frequencies

6 Conclusion

The range of frequencies tested varied from 1.1Hz to 1.7Hz. The predicted values deviated slightly with change in frequency. There seemed to be a greater dependence on the drag force than on the frequency of the waves. This is due to the drag force not reflective of the frequency but simply on the dimensions of the cylinder. The velocity observed for frequency 1.5Hz is unreasonable high and would required more scrutiny. However, the observed velocities do appear to have reached a plateau at frequency 1.6Hz and 1.7 Hz. This study did show that the velocity of the cylinder is dependent on the frequencies of the waves and not on the amplitude of the waves.

It should be noted that there is virtually no detectable dependence on amplitude. This independence could be due to two reason. One is that the amplitude could not be set and the second is that the amplitudes produced were not constant. The amplitudes during one run was observed to vary by as much as one inch. This is a large deviation since the larger amplitude tested was 2.5inches.

The theory should be considered as a ball-park figure when estimating velocities for frequencies where forces besides drag, damping, and excitation are known to exist. It is recommended that higher frequencies be tested and that frequency 1.45Hz be tested. Since the predicted and the observed values did not correlate it is also recommended that the derivation of the displacement equation include all of the forces present. And that a more accurate representation of the drag force which is dependent on the frequency and the amplitude of the waves be derived.

7 Appendix A: Graphs of all Recorded Data

The following are the graphs of all the frequencies and amplitudes tested along with the best fit curves and the average velocities. The best fit curves represent the slope which best fits through the points, this slope does not take into account the path of the cylinder. The average velocity represents the velocity of the cylinder in a near linear path.

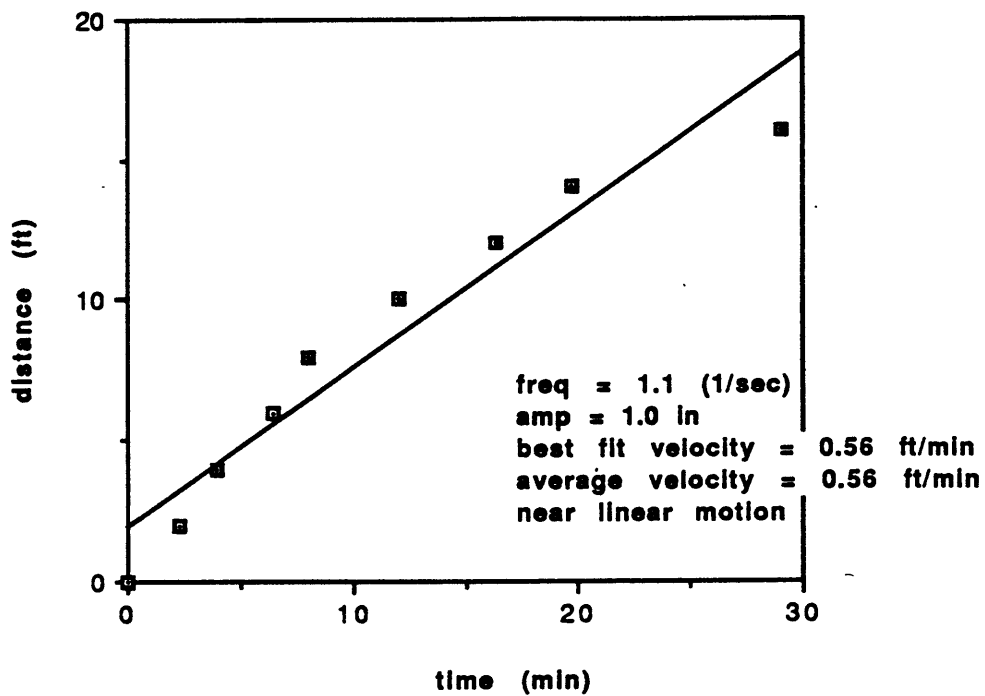

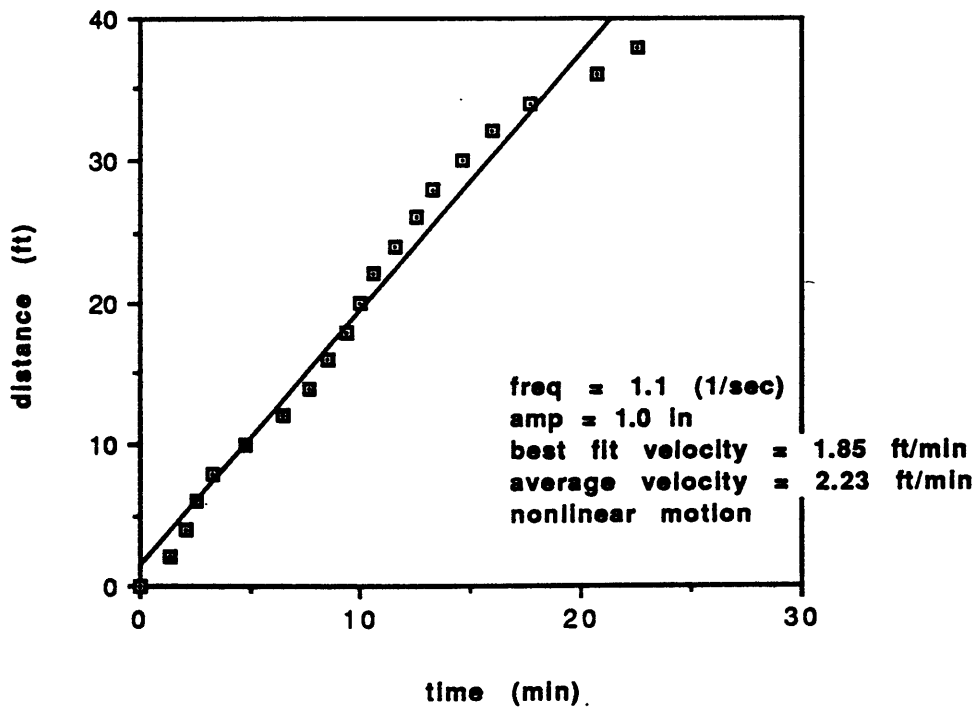
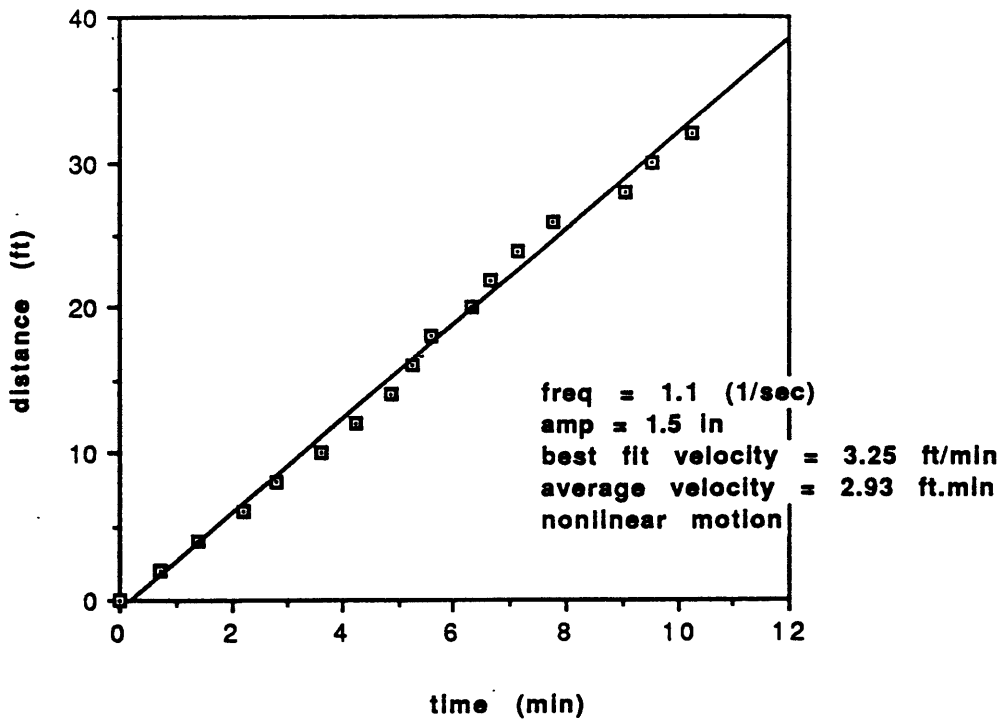

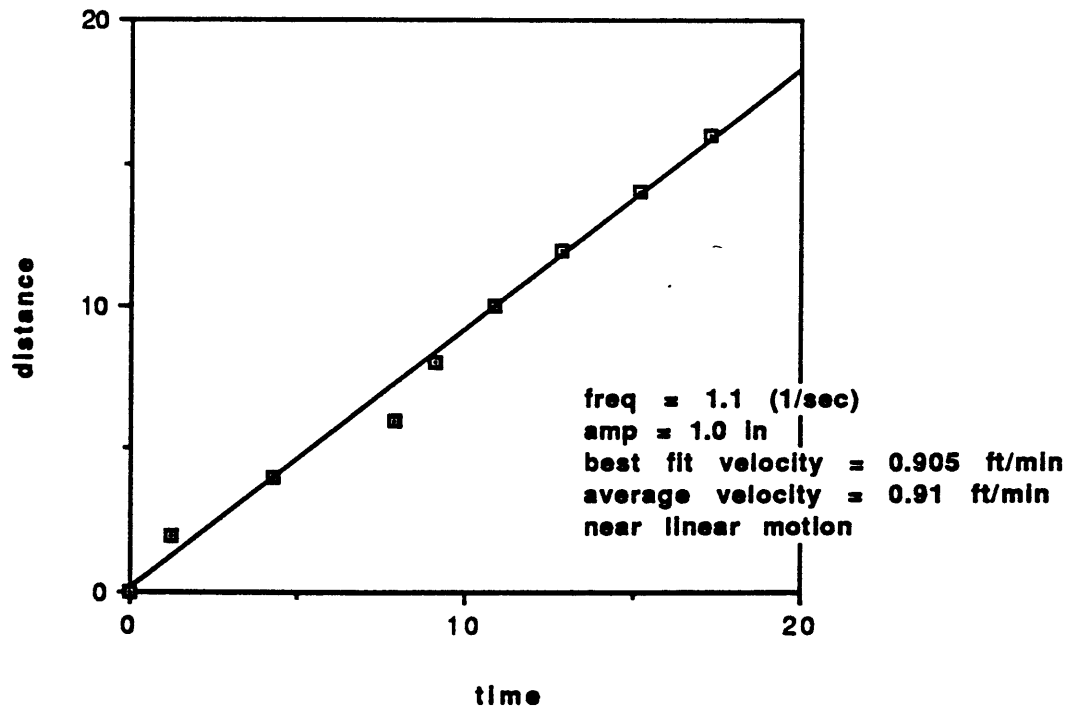
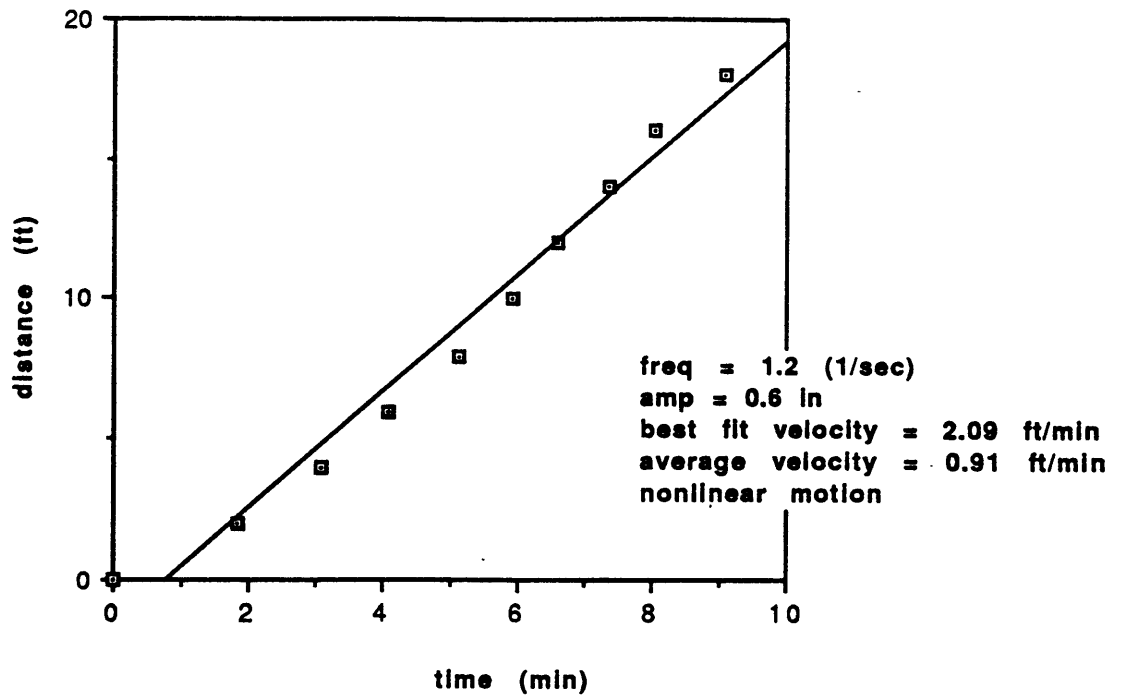

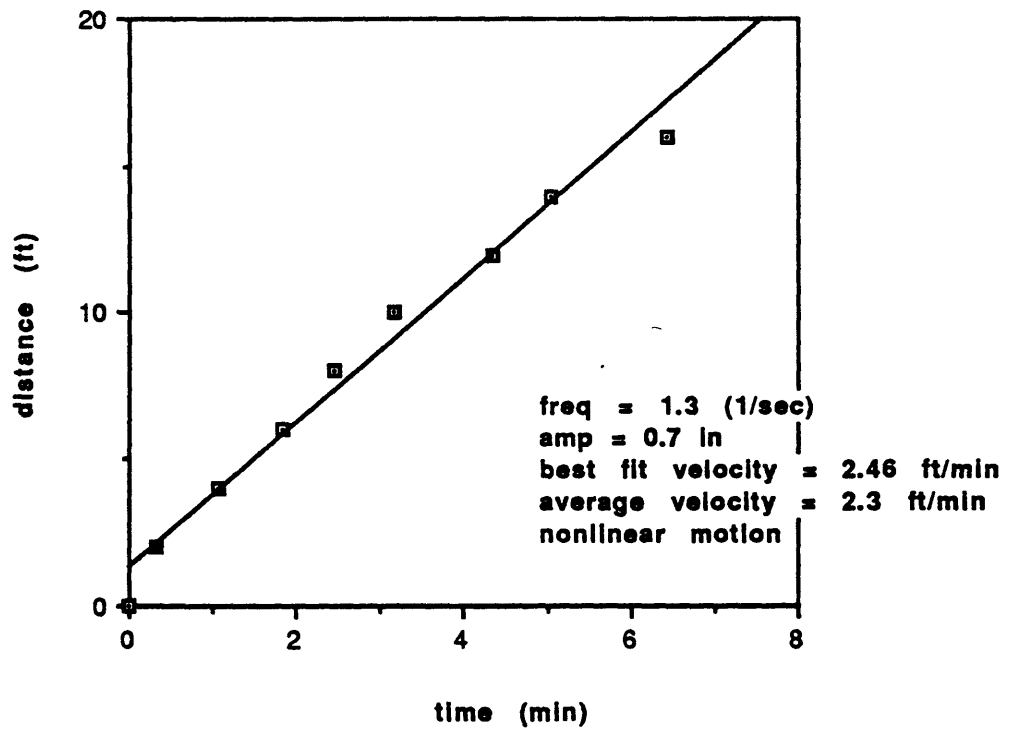
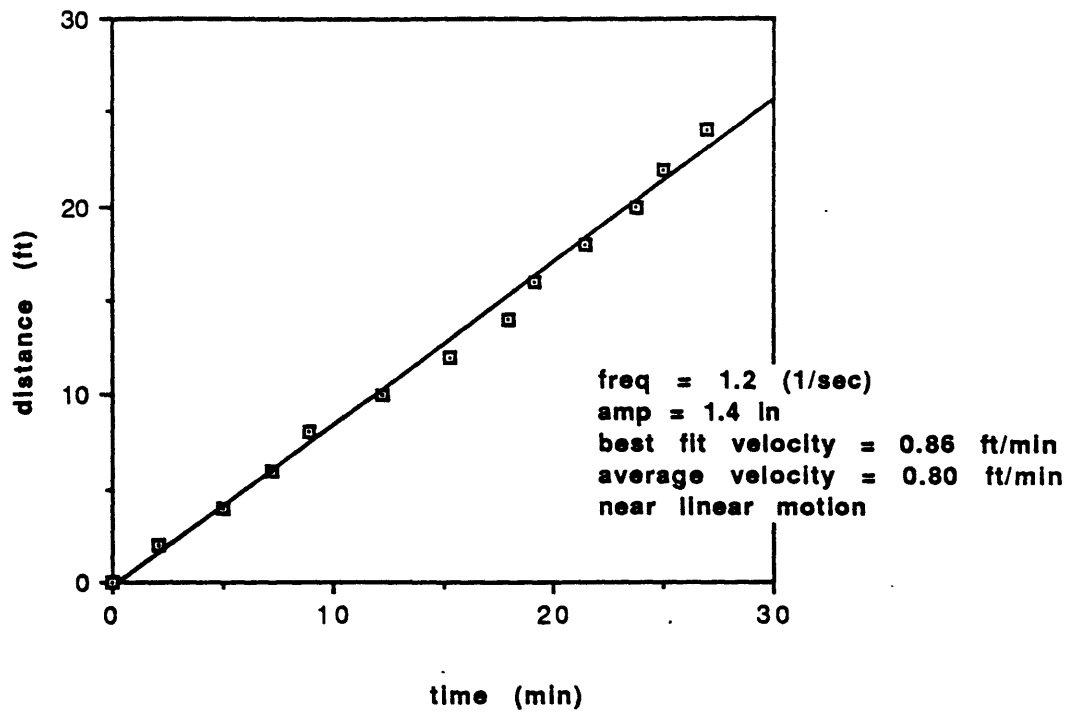

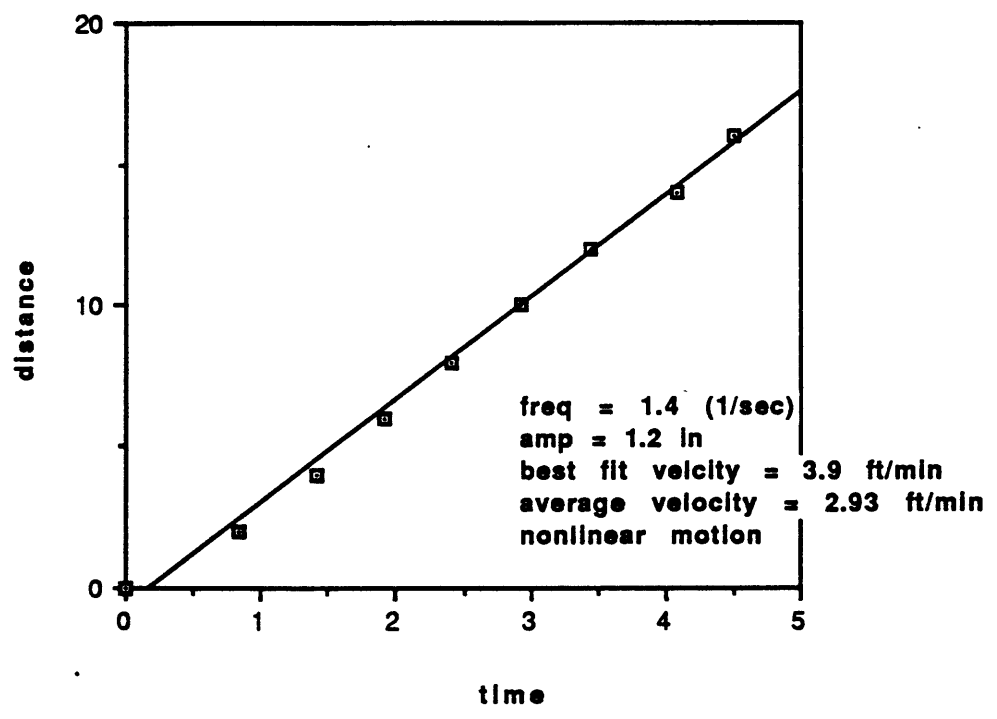
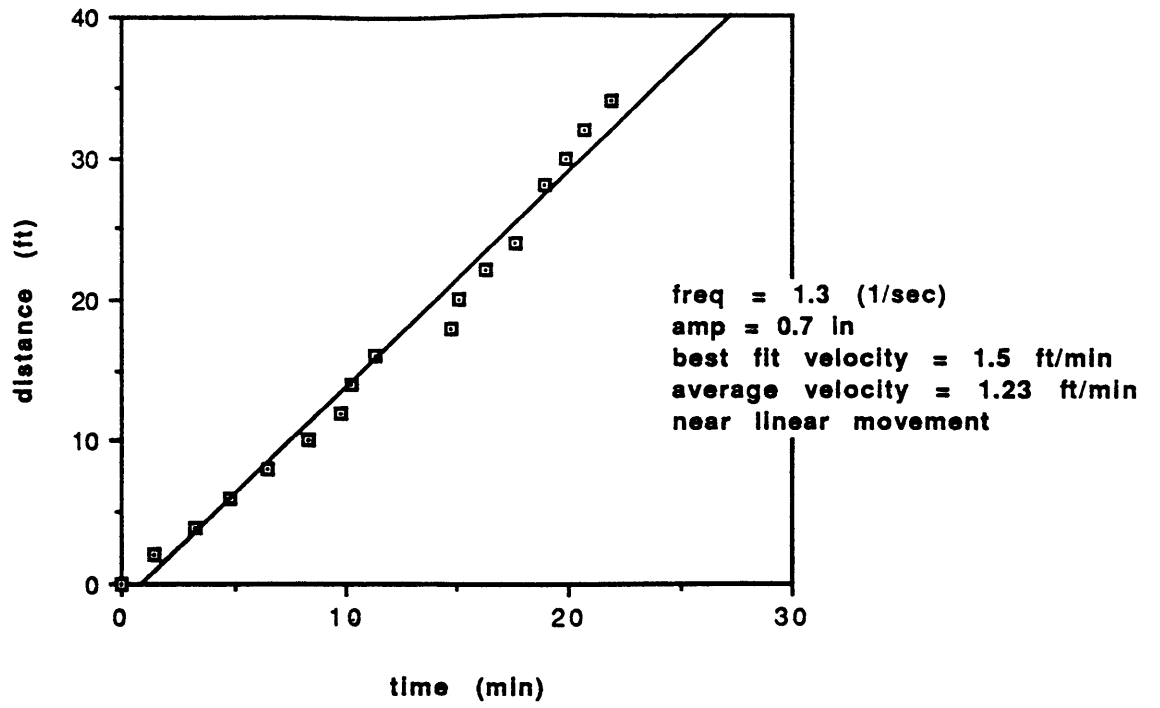

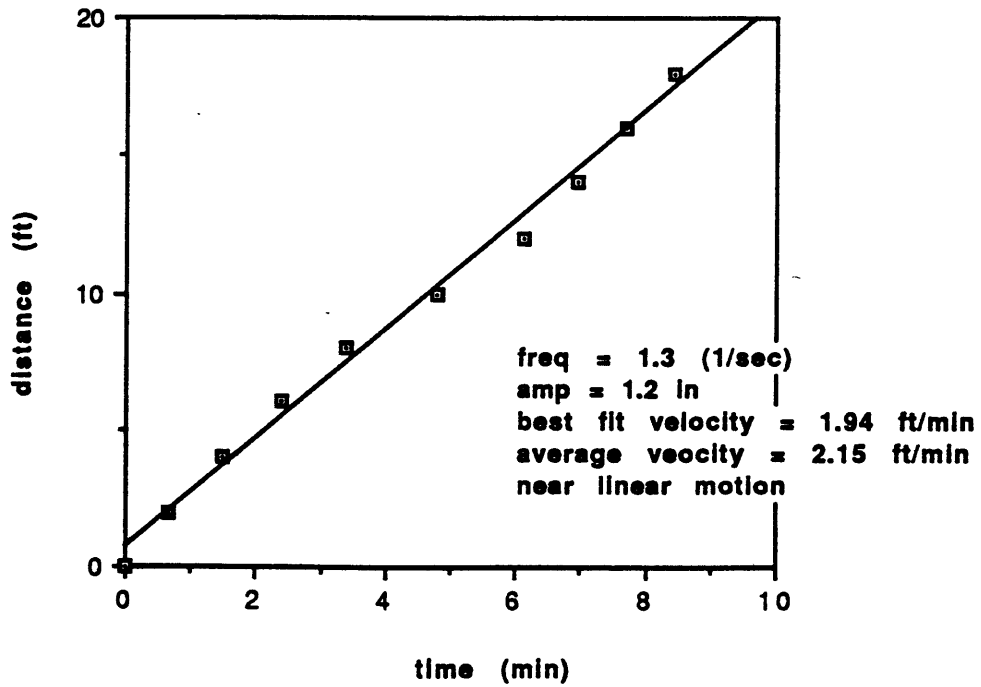
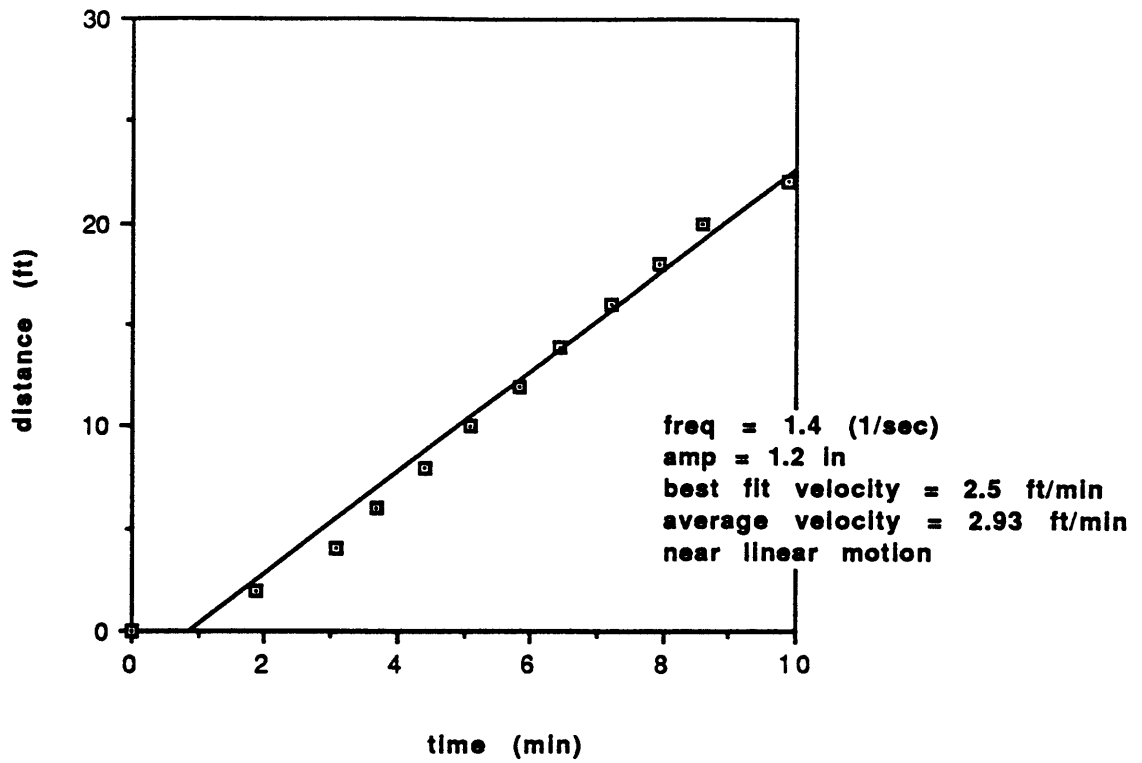

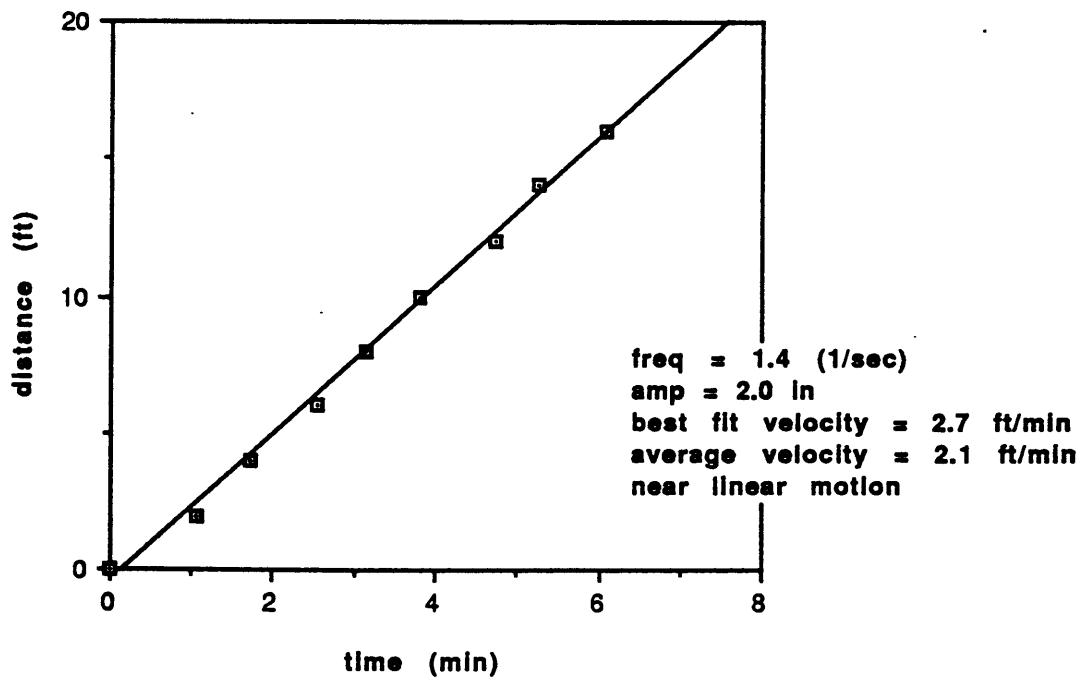
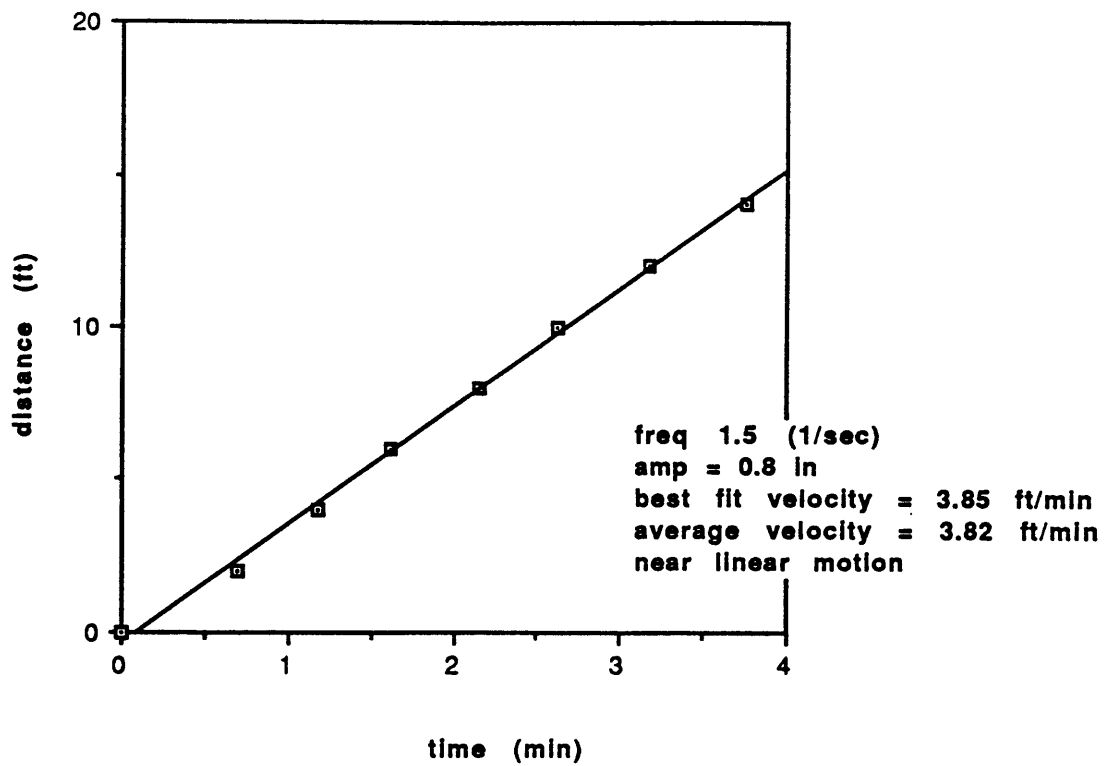

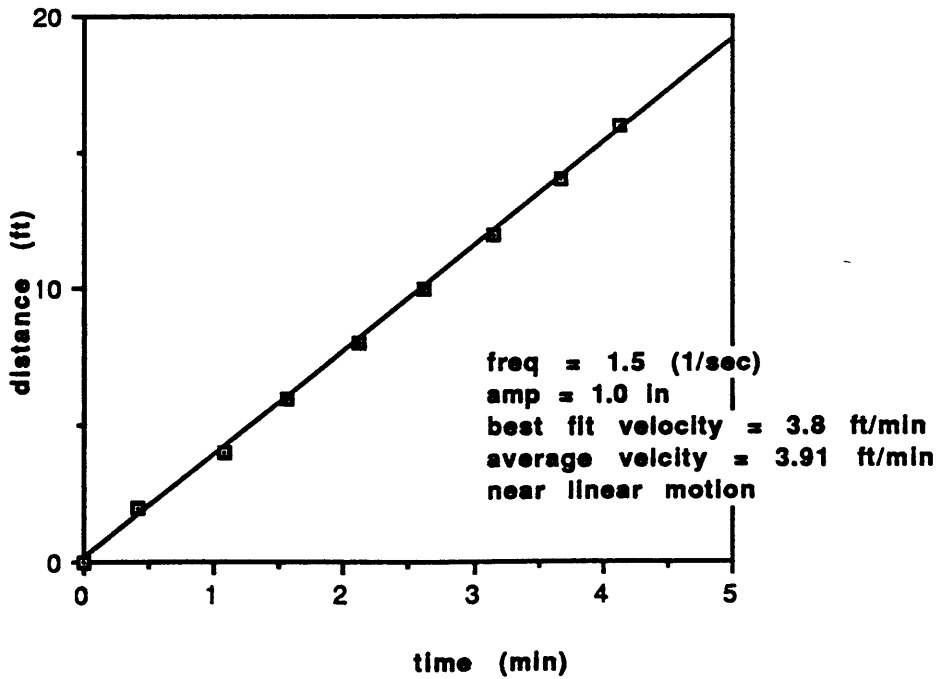
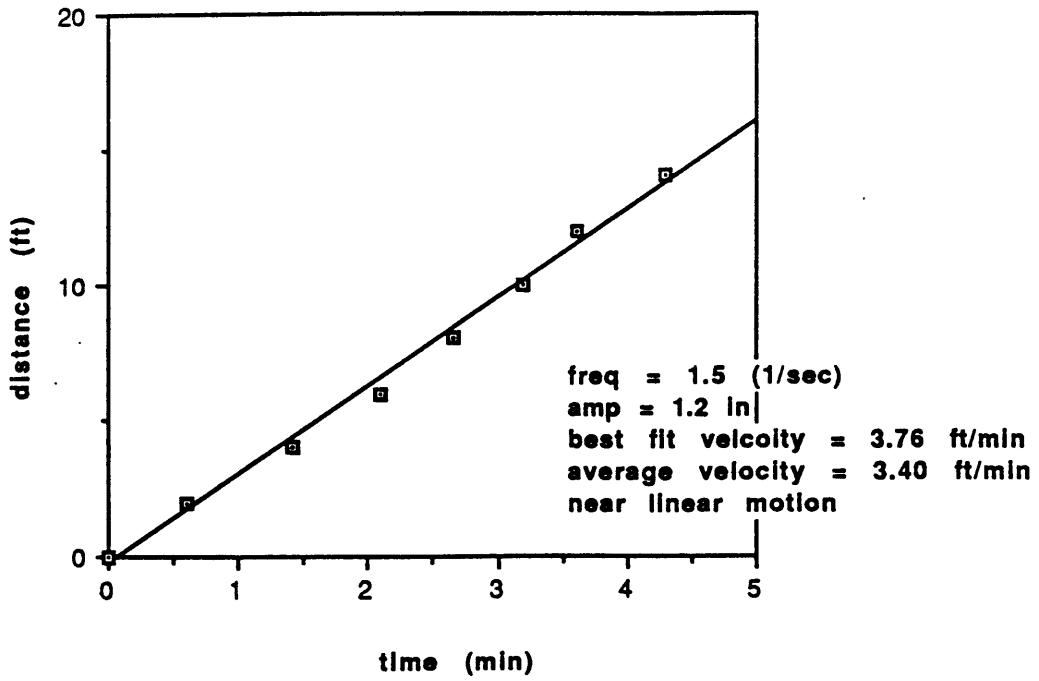

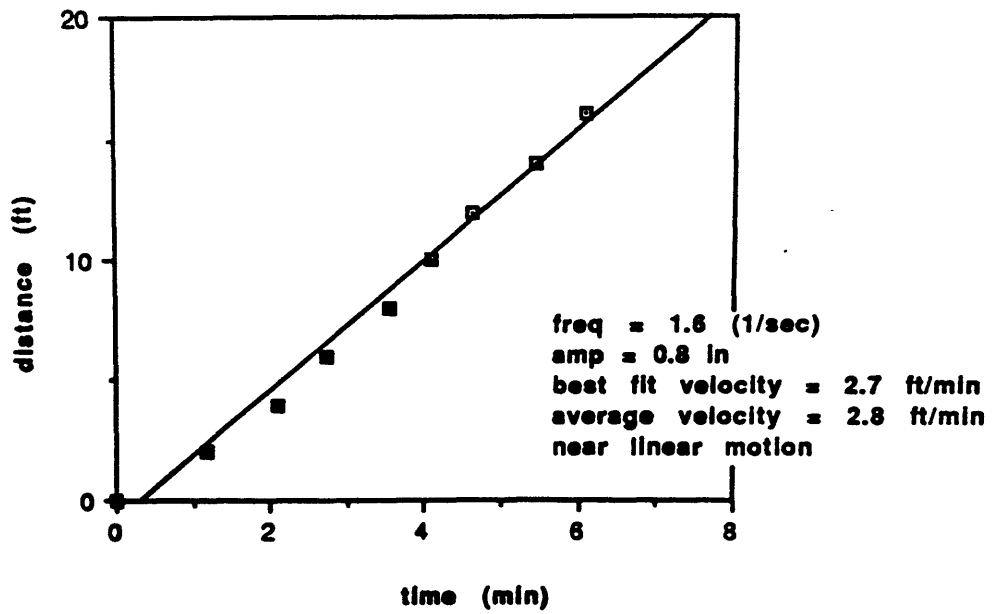
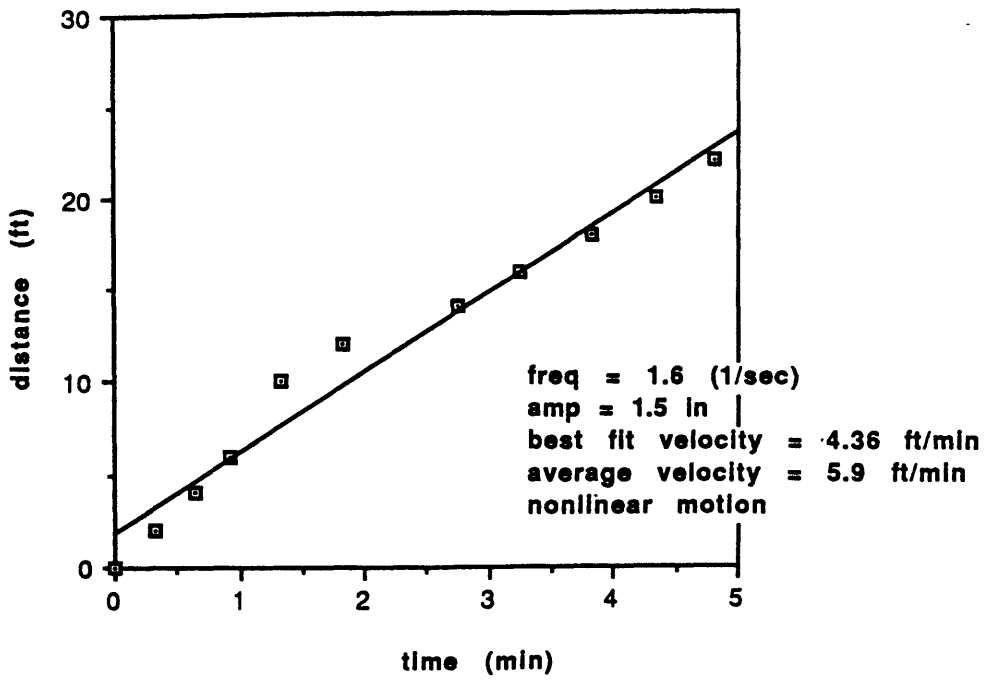

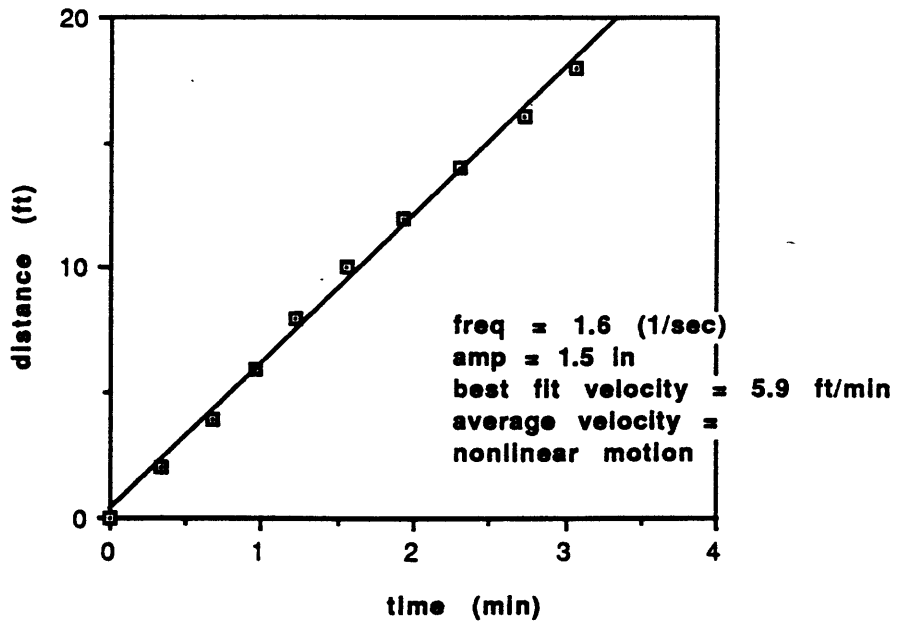
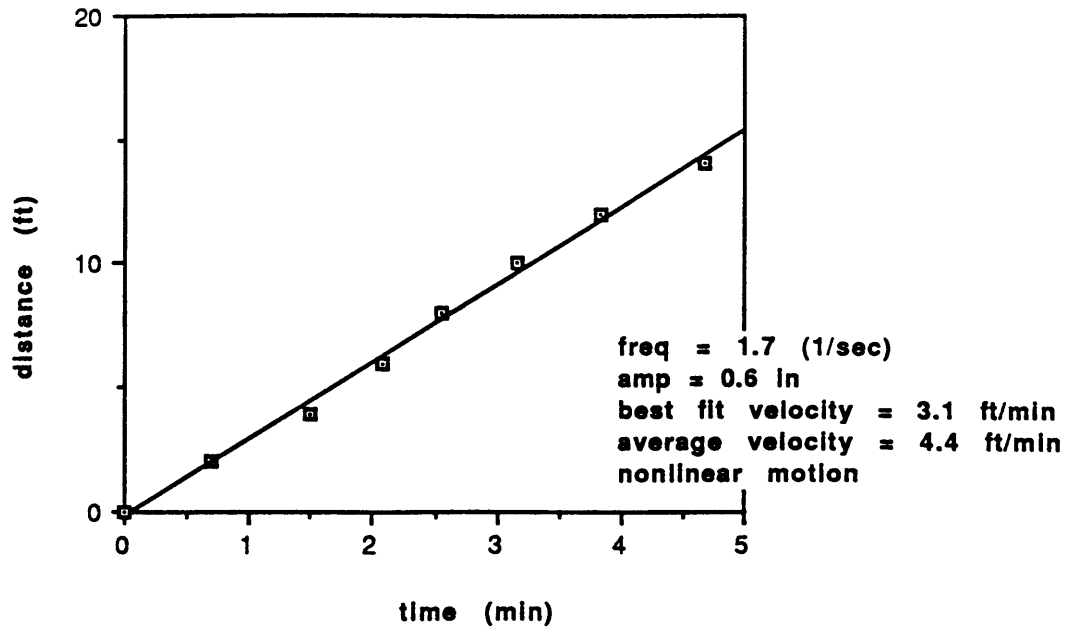

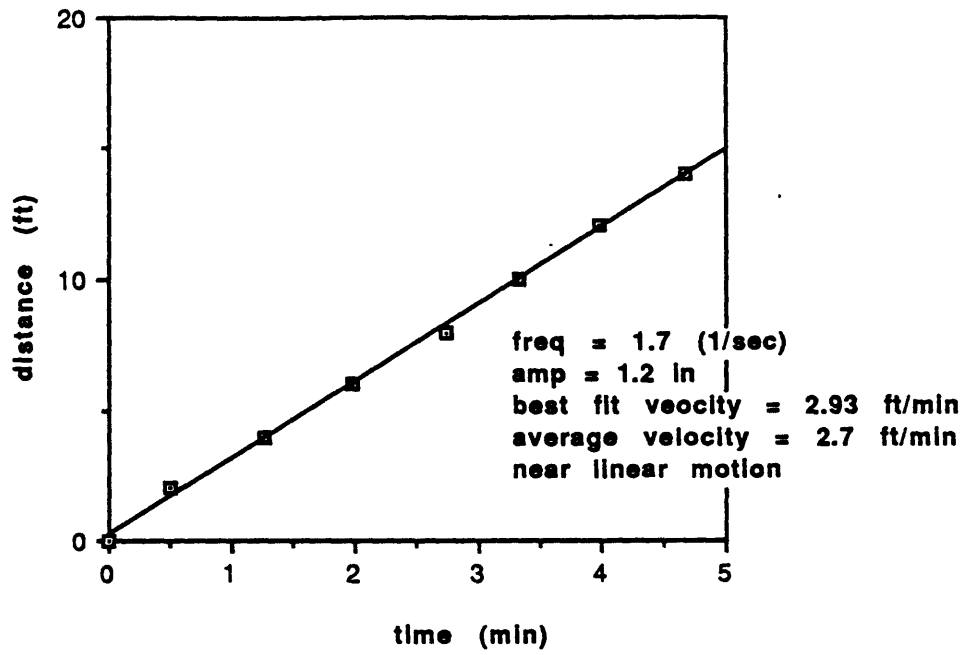

8 Appendix B: Towing Tank Characteristics

The characteristic of the MIT towing tank was derived as part of a class exercise in Marine Hydrodynamics (13.021). This was the second laboratory exercise and was titled 'Wave Kinematics With and Without Forward Speed'. The assignment was to calibrate the towing tank. The values which were evaluated included reflection coefficient, the wavelength as a function of frequency, the phase velocity, and the group velocity. The following is a summary of eight of the submitted papers.

These papers showed that the frequency generator was quite accurate. On the other hand, no calibration could be found for the amplitude potentiometer.

8.1 Reflection Coefficient

Since the beach installed in the tank is designed to absorb energy as opposed to waves, a reflection coefficient was expected. It was measured by running a wave probe up and down the tank at slow speeds. The probe recorded the maximum and the minimum amplitudes in its path. These values were then used in the following equation to determine the reflection coefficient.

$$R = \frac{\text{maxamp} - \text{minamp}}{\text{maxamp} + \text{minamp}} \quad (2)$$

The average reflection coefficient value of the submitted reports is $R_{ave} = 0.132$.

8.2 Relation Between Wavelength and Frequency

The relationship between wavelength and frequency is

$$\lambda = \frac{g}{2\pi\omega^2} \quad (3)$$

The lab evaluated the wavemaker's ability to comply with this equation. The submitted papers reported little if any deviation from this equation.

Bibliography

Newman, J.N. Marine Hydrodynamics The MIT Press, Cambridge MA 1989.

Gerhart, Philip M. and Gross, Richard J. Fundamentals of Fluid Mechanics, Addison-Wesley Publishing Company, Reading, MA 1985.