

Beyond the Standard Model for Montañeros*

M. Bustamante¹, L. Cieri² and J. Ellis³

¹ Pontificia Universidad Católica del Perú, Lima, Peru

² Universidad de Buenos Aires, Buenos Aires, Argentina

³ CERN, Geneva, Switzerland

Abstract

These notes cover (i) *electroweak symmetry breaking* in the Standard Model (SM) and the Higgs boson, (ii) *alternatives to the SM Higgs boson* including an introduction to composite Higgs models and Higgsless models that invoke extra dimensions, (iii) the theory and phenomenology of *supersymmetry*, and (iv) various *further beyond topics*, including Grand Unification, proton decay and neutrino masses, supergravity, superstrings and extra dimensions.

1 The Standard Model, electroweak symmetry breaking and the Higgs boson

In this first Lecture, we review the electroweak sector of the Standard Model (SM) (for more detailed accounts, see, e.g., [1–3]), with particular emphasis on the nature of electroweak symmetry breaking. The theory grew out of experimental information on charged-current weak interactions, and of the realisation that the four-point Fermi description ceases to be valid above $\sqrt{s} = 600$ GeV [3]. Electroweak theory was able to predict the existence of neutral-current interactions, as discovered by the Gargamelle Collaboration in 1973 [4]. One of its greatest subsequent successes was the detection in 1983 of the W^\pm and Z^0 bosons [5–8], whose existences it had predicted. Over time, thanks to the accumulating experimental evidence, the $SU(2)_L \otimes U(1)_Y$ electroweak theory and $SU(3)_C$ quantum electrodynamics, collectively known as the Standard Model, have come to be regarded as the correct description of electromagnetic, weak and strong interactions up to the energies that have been probed so far. However, although the SM has many successes, it also has some shortcomings, as we also indicate. In subsequent Lectures we discuss ideas for rectifying (at least some of) these defects: see also [9–11].

The particle content of the SM is summarized in Table 1. Within the SM, the electromagnetic and weak interactions are described by a Lagrangian that is symmetric under local weak isospin and hypercharge gauge transformations, described using the $SU(2)_L \otimes U(1)_Y$ group (the L subindex refers to the fact that the weak $SU(2)$ group acts only the left-handed projections of fermion states; Y is the hypercharge). We can write the $SU(2)_L \otimes U(1)_Y$ part of the SM Lagrangian as

$$\begin{aligned} \mathcal{L} &= -\frac{1}{4} \mathbf{F}_{\mu\nu}^a \mathbf{F}^{a\mu\nu} \\ &+ i \bar{\psi} \not{D} \psi + h.c. \\ &+ \psi_i y_{ij} \psi_j \phi + h.c. \\ &+ |D_\mu \phi|^2 - V(\phi) . \end{aligned} \tag{1}$$

This is short enough to write on a T-shirt!

The first line is the kinetic term for the gauge sector of the electroweak theory, with a running over the total number of gauge fields: three associated with $SU(2)_L$, which we shall call $B_\mu^1, B_\mu^2, B_\mu^3$, and one with $U(1)_Y$, which we shall call \mathcal{A}_μ . Their field-strength tensors are

$$F_{\mu\nu}^a = \partial_\nu B_\mu^a - \partial_\mu B_\nu^a + g \varepsilon_{bca} B_\mu^b B_\nu^c \text{ for } a = 1, 2, 3 \tag{2}$$

$$f_{\mu\nu} = \partial_\nu \mathcal{A}_\mu - \partial_\mu \mathcal{A}_\nu . \tag{3}$$

*Based on lectures by John Ellis at the 2009 CERN–CLAF School of High-Energy Physics, Medellín, Colombia.

Table 1: Particle content of the Standard Model with a minimal Higgs sector.

Bosons		Scalars	
$\gamma, W^+, W^-, Z^0, g_{1\dots 8}$		ϕ (Higgs)	
Fermions			
Quarks (each with 3 colour charges)		Leptons	
$2/3 :$	$\begin{pmatrix} u \\ c \\ t \end{pmatrix}$	neutral :	$\begin{pmatrix} \nu_e \\ \nu_\mu \\ \nu_\tau \end{pmatrix}$
$-1/3 :$	$\begin{pmatrix} d \\ s \\ b \end{pmatrix}$	$-1 :$	$\begin{pmatrix} e^- \\ \mu^- \\ \tau^- \end{pmatrix}$

In Eq. (2), g is the coupling constant of the weak-isospin group $SU(2)_L$, and the ε_{bca} are its structure constants. The last term in this equation stems from the non-Abelian nature of $SU(2)$. At this point, all of the gauge fields are massless, but we will see later that specific linear combinations of the four electroweak gauge fields acquire masses through the Higgs mechanism.

The second line in Eq. (1) describes the interactions between the matter fields ψ , described by Dirac equations, and the gauge fields.

The third line is the Yukawa sector and incorporates the interactions between the matter fields and the Higgs field, ϕ , which are responsible for giving fermions their masses when electroweak symmetry breaking occurs.

The fourth and final line describes the scalar or Higgs sector. The first piece is the kinetic term with the covariant derivative defined here to be

$$D_\mu = \partial_\mu + \frac{ig'}{2}\mathcal{A}_\mu Y + \frac{ig}{2}\boldsymbol{\tau} \cdot \mathbf{B}_\mu, \quad (4)$$

where g' is the $U(1)$ coupling constant, and Y and $\boldsymbol{\tau} \equiv (\tau_1, \tau_2, \tau_3)$ (the Pauli matrices) are, respectively, the generators of $U(1)$ and $SU(2)$. The second piece of the final line of (1) is the Higgs potential $V(\phi)$.

Whereas the first two lines of (1) have been confirmed in many different experiments, there is no experimental evidence for the last two lines and one of the main objectives of the LHC is to discover whether it is right, needs modification, or is simply wrong.

1.1 The Higgs mechanism in $U(1)$

To explain the Higgs mechanism of mass generation, we first apply it to the gauge group $U(1)$, and then extend it to the full electroweak group $SU(2)_L \otimes U(1)_Y$. Thus, we first consider the following Lagrangian for a single complex scalar field:

$$\mathcal{L} = (\partial_\mu \phi)^* (\partial^\mu \phi) - V(\phi^* \phi), \quad (5)$$

with the potential defined as

$$V(\phi^* \phi) = \mu^2 (\phi^* \phi) + \lambda (\phi^* \phi)^2, \quad (6)$$

where μ^2 and $\lambda > 0$ are real constants. This Lagrangian is clearly invariant under global $U(1)$ phase transformations

$$\phi \rightarrow e^{i\alpha} \phi, \quad (7)$$

for α some rotation angle. Equivalently, it is invariant under a $SO(2)$ rotational symmetry, which is made evident by writing \mathcal{L} in terms of the decomposition of the complex scalar field into two real fields ϕ_1 and ϕ_2 : $\phi \equiv \phi_1 + i\phi_2$.

If we choose $\mu^2 > 0$ in (8), the sole vacuum state has $\langle \phi \rangle = 0$. Perturbing around this vacuum reveals that, in this case, the scalar-sector Lagrangian simply factors into two Klein–Gordon Lagrangians, one for ϕ_1 and the other for ϕ_2 , with a common mass. The symmetry of the original Lagrangian is preserved in this case.

However, when $\mu^2 < 0$, the Lagrangian (5) exhibits spontaneous breaking of the $U(1)$ global symmetry, which introduces a massless scalar particle known as a Goldstone boson, as we now show. In order to make manifest this breaking of the $U(1)$ symmetry present in Eq. (5), we first minimize the potential (6) so as to identify the vacuum expectation value, or v.e.v., of the scalar field. To do this, we first write the Higgs potential as

$$V(\phi^* \phi) = \mu^2 (\phi_1^2 + \phi_2^2) + \lambda (\phi_1^2 + \phi_2^2)^2, \quad (8)$$

and note that minimization with respect to $\phi^* \phi$ yields the value

$$\phi_1^2 + \phi_2^2 = -\mu^2 / (2\lambda), \quad (9)$$

i.e., there is a set of equivalent minima lying around a circle of radius $\sqrt{-\mu^2 / (2\lambda)}$, when $\mu^2 < 0$ as assumed. The quanta of the Higgs field arise when a particular ground state is chosen and perturbed. Reflecting the appearance of spontaneous symmetry breaking we may, without loss of generality, choose for instance

$$\phi_{1,\text{vac}} = \sqrt{-\mu^2 / (2\lambda)} \equiv v / \sqrt{2}, \quad \phi_{2,\text{vac}} = 0. \quad (10)$$

Perturbations around this vacuum may be parametrized by

$$\eta / \sqrt{2} \equiv \phi_1 - v / \sqrt{2}, \quad \xi / \sqrt{2} \equiv \phi_2, \quad (11)$$

so that the perturbed complex scalar is $\phi = (v + \eta + i\xi) / \sqrt{2}$, where η and ξ are real fields. In terms of these, the Lagrangian becomes

$$\begin{aligned} \mathcal{L} = & \left[\frac{1}{2} (\partial^\mu \eta) (\partial_\mu \eta) - \frac{\mu^2}{2} \eta^2 \right] + \frac{1}{2} (\partial^\mu \xi) (\partial_\mu \xi) \\ & - \frac{\lambda}{2} [(v + \eta)^2 + \xi^2]^2 - \mu^2 v \eta - \frac{\mu^2}{2} \xi^2 - \frac{1}{2} \mu^2 v^2. \end{aligned} \quad (12)$$

The first and second terms describe two scalar particles: the first, η , is massive with $m_\eta^2 = -\mu^2 > 0$ (we recall that $\mu^2 < 0$), and the second, ξ , is massless, the Goldstone boson.

We now discuss how this spontaneous symmetry breaking manifests itself in the presence of a $U(1)$ gauge field. For this purpose, we make the Lagrangian (5) invariant under local $U(1)$ phase transformations, i.e.,

$$\phi \rightarrow e^{i\alpha(x)} \phi. \quad (13)$$

This requires the introduction of a gauge field \mathcal{A}_μ that transforms as follows under $U(1)$:

$$\mathcal{A}'_\mu \rightarrow \mathcal{A}_\mu + (1/q) \partial_\mu \alpha(x), \quad (14)$$

and replacing the space-time derivatives by covariant derivatives

$$D_\mu = \partial_\mu + iq\mathcal{A}_\mu, \quad (15)$$

where q is the conserved charge. Replacing the derivatives in Eq. (5) and adding a kinetic term for the \mathcal{A}_μ field, the Lagrangian becomes

$$\mathcal{L} = [(\partial_\mu - iq\mathcal{A}_\mu) \phi^*][(\partial^\mu + iq\mathcal{A}^\mu) \phi] - V(\phi^* \phi) - \frac{1}{4} F^{\mu\nu} F_{\mu\nu}. \quad (16)$$

The last term in this equation, $(1/4) F^{\mu\nu} F_{\mu\nu}$, with $F_{\mu\nu} \equiv \partial_\nu \mathcal{A}_\mu - \partial_\mu \mathcal{A}_\nu$, is the kinetic term, which is separately invariant under the transformation (14) of the gauge field.

We now repeat the minimization of the potential $V(\phi)$ and write the Lagrangian in terms of the perturbations around the ground state, Eqs. (11):

$$\begin{aligned} \mathcal{L} = & \left\{ \frac{1}{2} [(\partial^\mu \eta)(\partial_\mu \eta) - \mu^2 \eta^2] + \frac{1}{2} (\partial^\mu \xi)(\partial_\mu \xi) - \frac{1}{4} F^{\mu\nu} F_{\mu\nu} + \frac{1}{2} q^2 v^2 \mathcal{A}^\mu \mathcal{A}_\mu \right\} \\ & + v q^2 A^\mu \mathcal{A}_\mu \eta + \frac{q^2}{2} \mathcal{A}^\mu \mathcal{A}_\mu \eta^2 + q (\partial^\mu \xi) \mathcal{A}_\mu (v + \eta) - q (\partial^\mu \eta) \mathcal{A}_\mu \xi \\ & - \mu^2 v \eta - \frac{\mu^2}{2} \xi^2 - \frac{\lambda}{2} [(v + \eta) + \xi^2]^2 - \frac{\mu^2 v}{2} . \end{aligned} \quad (17)$$

The first three terms again describe a (real) scalar particle, η , of mass $\sqrt{-\mu^2}$ and a massless Goldstone boson, ξ . The fourth term describes the free gauge field. However, whereas previously the Lagrangian described a massless boson field [see Eq. (12)], now it contains a term proportional to $\mathcal{A}_\mu \mathcal{A}^\mu$, which gives the gauge field a mass of

$$m_{\mathcal{A}} = qv , \quad (18)$$

from which we see that the boson field has acquired a mass that is proportional to the vacuum expectation value of the Higgs field. Indeed, the last two terms in the first line of Eq. (12) are identical with the Proca Lagrangian for a $U(1)$ gauge boson of mass m .

The rest of the terms in Eq. (12) define couplings between the fields A^μ , η and ξ , among which is a bilinear interaction coupling A^μ and $\partial_\mu \xi$. In order to give the correct propagating particle interpretation of (12), we must diagonalize the bilinear terms and remove this term. This is easily done by exploiting the gauge freedom of the \mathcal{A}_μ field to replace

$$\mathcal{A}_\mu \rightarrow \mathcal{A}'_\mu = \mathcal{A}_\mu + \frac{1}{qv} \partial_\mu \xi , \quad (19)$$

which is accompanied by the local phase transformation

$$\phi \rightarrow \phi' = e^{-i\xi(x)/v} \phi = (v + \eta) / \sqrt{2} . \quad (20)$$

After making this transformation, the field ξ no longer appears, and the Lagrangian (12) takes the simplified form

$$\mathcal{L} = \frac{1}{2} [(\partial^\mu \eta)(\partial_\mu \eta) - \mu^2 \eta^2] - \frac{1}{4} F^{\mu\nu} F_{\mu\nu} + \frac{q^2 v^2}{2} \mathcal{A}^{\mu'} \mathcal{A}'_\mu + \dots \quad (21)$$

where the \dots represent trilinear and quadrilinear interactions.

The interpretation of (21) is that the Goldstone boson ξ that appeared when the global $U(1)$ symmetry was broken by the choice of an asymmetric ground state when $\mu^2 < 0$ has been absorbed (or ‘eaten’) by the gauge field \mathcal{A}_μ , with the effect of generating a mass. Another way to understand this is to recall that, whereas a massless gauge boson has only two degrees of freedom, or polarization states (which are transverse), a massive gauge boson must have a third (longitudinal) polarization state. In the Higgs mechanism, this is supplied by the Goldstone boson of the spontaneously-broken $U(1)$ global symmetry.

At first sight, the Higgs mechanism may seem somewhat artificial. From one point of view, it is merely a description of the breaking of electroweak symmetry, rather than an explanation of how a massless gauge boson may become massive. As Quigg says [12], the electroweak symmetry is broken because $\mu^2 < 0$, and we must choose $\mu^2 < 0$, because otherwise electroweak symmetry is not broken. From another point of view, the *only* consistent formulation of an interacting massive gauge boson is *via* the Higgs mechanism, and the spontaneous breaking of symmetry is a mathematical ruse for describing this phenomenon.

1.2 The Higgs mechanism in $SU(2)_L \otimes U(1)_Y$

Following closely in both spirit and notation the book by Quigg [12], we now consider the weak-isospin doublet

$$\mathbf{L} = \begin{pmatrix} \nu \\ e \end{pmatrix}_L, \quad (22)$$

with the left-handed neutrino and electron states defined by

$$\nu_L = \frac{1}{2}(1 - \gamma_5)\nu, \quad e_L = \frac{1}{2}(1 - \gamma_5)e. \quad (23)$$

The operator $(1 - \gamma_5)/2$ is of course the left-handed helicity projector, and ν, e are solutions of the free-field Dirac equation. Within the SM, we consider the neutrino to be massless, and it does not have a corresponding right-handed component, i.e.,

$$\nu_R = \frac{1}{2}(1 + \gamma_5)\nu = 0. \quad (24)$$

Hence, the only right-handed lepton, e_R , constitutes a weak-isospin singlet, i.e.,

$$\mathbf{R} = e_R = \frac{1}{2}(1 + \gamma_5)e. \quad (25)$$

We write initially the Lagrangian as

$$\mathcal{L} = \mathcal{L}_{\text{gauge}} + \mathcal{L}_{\text{leptons}} \quad (26)$$

$$\mathcal{L}_{\text{gauge}} = -\frac{1}{4}F_{\mu\nu}^a F^{a\mu\nu} - \frac{1}{4}f_{\mu\nu} f^{\mu\nu} \quad (27)$$

$$\mathcal{L}_{\text{leptons}} = \bar{\mathbf{R}} \left(\partial_\mu + i\frac{g'}{2}\mathcal{A}_\mu Y \right) \mathbf{R} + \bar{\mathbf{L}} i\gamma^\mu \left(\partial_\mu + i\frac{g'}{2}\mathcal{A}_\mu Y + i\frac{g}{2}\boldsymbol{\tau} \cdot \mathbf{B}_\mu \right) \mathbf{L}, \quad (28)$$

where the field-strength tensors, $F_{\mu\nu}$ and $f_{\mu\nu}$, were defined in Eqs. (2) and (3), respectively. Here, $g'/2$ is the coupling constant associated to the hypercharge group $U(1)_Y$, and $g/2$ is the coupling to the weak-isospin group $SU(2)_L$. So far, we are presented with four massless bosons ($\mathcal{A}_\mu, B_\mu^1, B_\mu^2, B_\mu^3$); the Higgs mechanism will select linear combinations of these to produce three massive bosons (W^\pm, Z^0) and a massless one (γ).

The Higgs field is now a complex $SU(2)$ doublet

$$\phi = \begin{pmatrix} \phi^+ \\ \phi^0 \end{pmatrix}, \quad (29)$$

with ϕ^+ and ϕ^0 scalar fields. We need to add the Lagrangian

$$\mathcal{L}_{\text{Higgs}} = (D_\mu \phi)^\dagger (D^\mu \phi) - V(\phi^\dagger \phi), \quad (30)$$

with the Higgs potential given by analogy to Eq. (6) as

$$V(\phi^\dagger \phi) = \mu^2 (\phi^\dagger \phi) + \lambda (\phi^\dagger \phi)^2, \quad (31)$$

with $\lambda > 0$. We should also include the interaction Lagrangian between this scalar field and the fermionic matter fields, which occurs through Yukawa couplings,

$$\mathcal{L}_{\text{Yukawa}} = -G_e \left[\bar{\mathbf{R}} \phi^\dagger \mathbf{L} + \bar{\mathbf{L}} \phi \mathbf{R} \right]. \quad (32)$$

As we see later, these terms give rise to masses for the matter fermions.

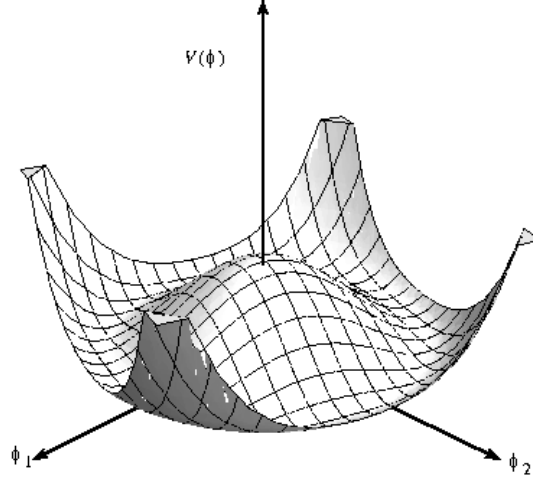

Fig. 1: Scalar potential $V(\phi^\dagger\phi)$ with $\lambda > 0$ and $\mu^2 < 0$

A plot of the Higgs potential is presented in Fig. 1.2, where we see that $\langle\phi\rangle = 0$ is an unstable local minimum of the effective potential if $\mu^2 < 0$, and that the minimum is at some $\langle\phi\rangle \neq 0$ with an arbitrary phase, leading to spontaneous symmetry breaking. Minimizing the Higgs potential, we obtain

$$\frac{\partial}{\partial(\phi^\dagger\phi)}V(\phi^\dagger\phi) = \mu^2 + 2\lambda\langle\phi\rangle_0 = \mu^2 + 2\lambda\left[(\phi_{\text{vac}}^+)^2 + (\phi_{\text{vac}}^0)^2\right] = 0. \quad (33)$$

Choosing $\phi_{\text{vac}}^+ = 0$ and $\phi_{\text{vac}}^0 = \sqrt{-\mu^2/(2\lambda)}$, the v.e.v. of the scalar field becomes

$$\langle\phi\rangle_0 = \begin{pmatrix} 0 \\ v/\sqrt{2} \end{pmatrix}, \quad (34)$$

with $v \equiv \sqrt{-\mu^2/\lambda}$. Selecting a particular v.e.v. breaks, of course, both $SU(2)_L$ and $U(1)_Y$ symmetries. Nevertheless, an invariance under the $U(1)_{\text{EM}}$ symmetry is preserved, with the charge operator as the generator. In the preceding section, we saw one example of the general theorem that, for every broken generator (i.e., every generator that does not leave the vacuum invariant), there would (in the absence of the Higgs mechanism) be a Goldstone boson.

In general, a generator \mathcal{G} leaves the vacuum invariant if

$$e^{i\alpha\mathcal{G}}\langle\phi\rangle_0 \simeq (1 + i\alpha\mathcal{G})\langle\phi\rangle_0 = \langle\phi\rangle_0, \quad (35)$$

which is satisfied when $\mathcal{G}\langle\phi\rangle_0 = 0$. Let's test whether the generators of $SU(2)_L \otimes U(1)_Y$ satisfy this condition:

$$\tau_1\langle\phi\rangle_0 = \begin{pmatrix} 0 & 1 \\ 1 & 0 \end{pmatrix} \begin{pmatrix} 0 \\ v/\sqrt{2} \end{pmatrix} = \begin{pmatrix} v/\sqrt{2} \\ 0 \end{pmatrix} \quad (36)$$

$$\tau_2\langle\phi\rangle_0 = \begin{pmatrix} 0 & -i \\ i & 0 \end{pmatrix} \begin{pmatrix} 0 \\ v/\sqrt{2} \end{pmatrix} = \begin{pmatrix} -iv/\sqrt{2} \\ 0 \end{pmatrix} \quad (37)$$

$$\tau_3\langle\phi\rangle_0 = \begin{pmatrix} 1 & 0 \\ 0 & -1 \end{pmatrix} \begin{pmatrix} 0 \\ v/\sqrt{2} \end{pmatrix} = \begin{pmatrix} 0 \\ -v/\sqrt{2} \end{pmatrix} \quad (38)$$

$$Y\langle\phi\rangle_0 = \langle\phi\rangle_0. \quad (39)$$

Thus, none of the generators leave the vacuum invariant. However, we note that

$$Q\langle\phi\rangle_0 = \frac{1}{2}(\tau_3 + Y)\langle\phi\rangle_0 = 0, \quad (40)$$

which is what we expected: the linear combination of generators corresponding to electric charge remains unbroken. Correspondingly, as we shall now see, whilst the photon remains massless, the other three gauge bosons acquire mass.

To see this, we now consider perturbations around the choice of vacuum. The full perturbed scalar field is

$$\phi = \exp\left(\frac{i\xi \cdot \tau}{2v}\right) \begin{pmatrix} 0 \\ (v + \eta)/\sqrt{2} \end{pmatrix}. \quad (41)$$

However, in analogy to what we did for the $U(1)$ Higgs in the previous section to rotate the Goldstone boson ξ away, we are also able here to gauge-transform the scalar ϕ and the gauge and matter fields, i.e.,

$$\phi \rightarrow \phi' = \exp\left(\frac{-i\xi \cdot \tau}{2v}\right) \phi = \begin{pmatrix} 0 \\ (v + \eta)/\sqrt{2} \end{pmatrix}. \quad (42)$$

$$\tau \cdot \mathbf{B}_\mu \rightarrow \tau \cdot \mathbf{B}'_\mu \quad (43)$$

$$\mathbf{L} \rightarrow \mathbf{L}' = \exp\left(\frac{-i\xi \cdot \tau}{2v}\right) \mathbf{L}, \quad (44)$$

while the \mathcal{A}_μ and \mathbf{R} remain invariant. It is possible to show that $\tau \cdot \mathbf{B}'_\mu = \tau \cdot \mathbf{B}_\mu - \xi \times \mathbf{B}_\mu \cdot \tau - (1/g) \partial_\mu (\xi \cdot \tau)$.

In the unitary gauge, we can write the perturbed state as

$$\langle \phi \rangle_0 \rightarrow \phi = \begin{pmatrix} 0 \\ (v + \eta)/\sqrt{2} \end{pmatrix}, \quad (45)$$

and the Lagrangian in the Yukawa sector, Eq. (32), becomes

$$\mathcal{L}_{\text{Yukawa}} = -G_e \left[\bar{e}_R \phi^\dagger \begin{pmatrix} \nu_L \\ e_L \end{pmatrix} + (\bar{\nu}_L \bar{e}_L) \phi e_R \right] = -G_e \frac{v + \eta}{\sqrt{2}} (\bar{e}_R e_L + \bar{e}_L e_R). \quad (46)$$

Defining $\bar{e} \equiv (\bar{e}_R, \bar{e}_L)$ and $e \equiv (e_L, e_R)^T$ yields

$$\mathcal{L}_{\text{Yukawa}} = -\frac{G_e v}{\sqrt{2}} \bar{e} e - \frac{G_e \eta}{\sqrt{2}} \bar{e} e, \quad (47)$$

so that the electron has acquired a mass

$$m_e = G_e v / \sqrt{2}. \quad (48)$$

Clearly, this mechanism may be applied to all the SM fermions, with the general feature that their masses are proportional to their Yukawa couplings to the Higgs field¹. This implies that the preferred decays of a Higgs boson into generic fermions f are into heavier species, as long as the Higgs mass $> 2m_f$.

To see the effect of spontaneous symmetry breaking on the scalar-sector Lagrangian, $\mathcal{L}_{\text{Higgs}}$ in Eq. (30), it is useful to calculate first

$$\phi^\dagger \phi = \left(\frac{v + \eta}{\sqrt{2}} \right)^2, \quad (49)$$

so that

$$V(\phi^\dagger \phi) = \mu^2 \left(\frac{v + \eta}{\sqrt{2}} \right)^2 + \lambda \left(\frac{v + \eta}{\sqrt{2}} \right)^4, \quad (50)$$

and we also need

$$D_\mu \phi = \partial_\mu \phi + \frac{ig'}{2} \mathcal{A}_\mu Y \phi + \frac{ig}{2} \tau \cdot \mathbf{B}_\mu \phi, \quad (51)$$

¹The Higgs couplings to quarks also induce their Cabibbo–Kobayashi–Maskawa mixing — see Eq. (93) below.

whose first term is simply

$$\partial_\mu \phi = \begin{pmatrix} 0 \\ \partial_\mu \eta / \sqrt{2} \end{pmatrix}. \quad (52)$$

Using Eqs. (36)–(39), we calculate the second and third terms, i.e.,

$$\frac{ig'}{2} \mathcal{A}_\mu Y \phi = \frac{ig'}{2} \mathcal{A}_\mu \phi = \frac{ig'}{2} \mathcal{A}_\mu \begin{pmatrix} 0 \\ (v + \eta) / \sqrt{2} \end{pmatrix}, \quad (53)$$

$$(\boldsymbol{\tau} \cdot \mathbf{B}_\mu) \phi = B_\mu^1 \begin{pmatrix} (v + \eta) / \sqrt{2} \\ 0 \end{pmatrix} + B_\mu^2 \begin{pmatrix} -i(v + \eta) / \sqrt{2} \\ 0 \end{pmatrix} + B_\mu^3 \begin{pmatrix} 0 \\ -(v + \eta) / \sqrt{2} \end{pmatrix} \quad (54)$$

Hence,

$$D_\mu \phi = \begin{pmatrix} \frac{ig}{2} \left(\frac{v + \eta}{\sqrt{2}} \right) (B_\mu^1 - iB_\mu^2) \\ \frac{1}{\sqrt{2}} \partial_\mu \eta + \left(\frac{v + \eta}{\sqrt{2}} \right) \frac{i}{2} (ig' \mathcal{A}_\mu - igB_\mu^3) \end{pmatrix} \quad (55)$$

and

$$(D^\mu \phi)^\dagger (D_\mu \phi) = \frac{g^2}{8} (v + \eta)^2 |B_\mu^1 - iB_\mu^2|^2 + \frac{1}{2} (\partial_\mu \eta) (\partial^\mu \eta) + \frac{1}{8} (v + \eta)^2 (g' \mathcal{A}_\mu - gB_\mu^3)^2. \quad (56)$$

With this, the scalar-sector Lagrangian becomes

$$\begin{aligned} \mathcal{L}_{\text{Higgs}} &= \left\{ \frac{1}{2} (\partial_\mu \eta) (\partial^\mu \eta) - \frac{\mu^2}{2} \eta^2 + \frac{v^2}{8} \left[g^2 |B_\mu^1 - iB_\mu^2|^2 + (g' \mathcal{A}_\mu - gB_\mu^3)^2 \right] \right\} \\ &+ \left\{ \frac{1}{8} (\eta^2 + 2v\eta) \left[g^2 |B_\mu^1 - iB_\mu^2|^2 + (g' \mathcal{A}_\mu - gB_\mu^3)^2 \right] \right. \\ &\left. - \frac{1}{4} \eta^4 - \lambda v \eta^3 - \frac{3}{2} \lambda v^2 \eta^2 - (\lambda v^3 + \mu^2 v) \eta - \left(\frac{\lambda v^4}{4} + \frac{\mu^2 v^2}{2} \right) \right\}. \quad (57) \end{aligned}$$

From the second term inside the first curly brackets, we see that the η field has acquired a mass; indeed, it is the Higgs boson, with non-zero mass. The terms inside the second curly brackets either describe interactions between the gauge and Higgs fields, or are constants that do not affect the physics.

It is convenient to define the charged gauge fields W_μ^\pm as linear combinations of the massless fields B_μ^1 and B_μ^2 , i.e.,

$$W_\mu^\pm \equiv \frac{B_\mu^1 \mp iB_\mu^2}{\sqrt{2}}, \quad (58)$$

and, analogously,

$$Z_\mu \equiv \frac{-g' \mathcal{A}_\mu + gB_\mu^3}{\sqrt{g^2 + g'^2}}, \quad (59)$$

$$A_\mu \equiv \frac{g \mathcal{A}_\mu + g' B_\mu^3}{\sqrt{g^2 + g'^2}}. \quad (60)$$

Writing the original fields \mathcal{A}_μ , B_μ^i in terms of the new fields, we have

$$B_\mu^1 = \frac{\sqrt{2}}{2} (W_\mu^- + W_\mu^+), \quad B_\mu^2 = \frac{\sqrt{2}}{2} (W_\mu^- - W_\mu^+), \quad (61)$$

$$B_\mu^3 = \frac{g'}{\sqrt{g^2 + g'^2}} \left(A_\mu + \frac{g}{g'} Z_\mu \right), \quad \mathcal{A}_\mu = \frac{g}{\sqrt{g^2 + g'^2}} \left(A_\mu - \frac{g'}{g} Z_\mu \right). \quad (62)$$

Making these replacements in the broken scalar-sector Lagrangian, Eq. (57), leads to

$$\mathcal{L}_{\text{Higgs}} = \left[\frac{1}{2} (\partial^\mu \eta) (\partial_\mu \eta) - \frac{\mu^2}{2} \eta^2 \right] + \frac{v^2 g^2}{8} W^{+\mu} W_\mu^+ + \frac{v^2 g^2}{8} W^{-\mu} W_\mu^- + \frac{(g^2 + g'^2) v^2}{8} Z^\mu Z_\mu$$

$$+ \dots, \quad (63)$$

and it is evident now that while the photon field \mathcal{A}_μ is massless due to the unbroken $U(1)_{\text{EM}}$ symmetry (i.e., the symmetry under $e^{iQ\alpha(x)}$ rotations), the vector bosons W^\pm and Z^0 have masses

$$m_W = gv/2, \quad m_Z = (v/2) \sqrt{g^2 + g'^2}. \quad (64)$$

We see again that the Higgs couplings to other particles, in this case the W^\pm and Z^0 , are related to their masses.

We also see that the masses of the neutral and charged weak-interaction bosons are related through

$$m_Z = m_W \sqrt{1 + g'^2/g^2}. \quad (65)$$

Experimentally, the weak gauge boson masses are known to high accuracy to be [13]

$$m_W = 80.399 \pm 0.023 \text{ GeV}, \quad m_Z = 91.1875 \pm 0.0021 \text{ GeV}, \quad (66)$$

which can be compared in detail with (65) only after the inclusions of radiative corrections. Meanwhile, the current experimental upper limit on the photon mass, based on plasma physics, is very stringent: $m_\gamma < 10^{-18}$ eV [14]. For the Higgs mass, we see from (57) that

$$m_H = -2\mu^2. \quad (67)$$

A priori, however, there is no theoretical prediction within the Standard Model, since μ is not determined by any of the known parameters of the Standard Model. Later we will see various ways in which experiments constrain the Higgs mass.

We can introduce a weak mixing angle θ_W to parametrize the mixing of the neutral gauge bosons, defined by

$$\tan(\theta_W) = g'/g, \quad (68)$$

so that

$$\cos(\theta_W) = \frac{g}{\sqrt{g^2 + g'^2}}, \quad \sin(\theta_W) = \frac{g'}{\sqrt{g^2 + g'^2}}. \quad (69)$$

With this, we can write, from Eqs. (59) and (60),

$$Z_\mu = -\sin(\theta_W) \mathcal{A}_\mu + \cos(\theta_W) B_\mu^3, \quad (70)$$

$$A_\mu = \cos(\theta_W) \mathcal{A}_\mu + \sin(\theta_W) B_\mu^3. \quad (71)$$

The relation (65) between the masses of W^\pm and Z^0 becomes

$$m_W = m_Z \cos(\theta_W), \quad (72)$$

and it is common practice to define the ratio

$$\rho = \frac{m_W^2}{m_Z^2 \cos^2(\theta_W)}. \quad (73)$$

According to the Standard Model, this is equal to unity at the tree level, a prediction that has been well tested by experiment, including radiative corrections. The value of $\sin^2(\theta_W)$ is obtained from measurements of the Z pole and neutral-current processes, and depends on the renormalization prescription. The 2008 Particle Data Group review [13] states values of $\sin^2(\theta_W) = 0.2319(14)$ and $\rho = 1.0004_{-0.0004}^{+0.0008}$.

Therefore, after the spontaneous breaking of the electroweak $SU(2)_L \otimes U(1)_Y$ symmetry, we have ended up with what we desired: three massive gauge bosons (W^\pm , Z^0) that mediate weak interactions, one massless gauge boson (A) corresponding to the photon, and an extra, massive, Higgs boson (H).

1.3 QCD

The QCD Lagrangian has a structure similar to that of the electroweak Lagrangian [13], being also a gauge theory, but based on the group $SU(3)$ and without spontaneous symmetry breaking:

$$\mathcal{L}_{\text{QCD}} = -\frac{1}{4}F_{\mu\nu}^a F^{a\ \mu\nu} + i \sum_q \bar{\psi}_q^i \gamma^\mu (D_\mu)_{ij} \psi_q^j - \sum_q m_q \bar{\psi}_q^i \psi_q^i, \quad (74)$$

$$F_{\mu\nu}^a = \partial_\mu A_\nu^a - \partial_\nu A_\mu^a - g_s f_{abc} A_\mu^b A_\nu^c, \quad (75)$$

$$(D_\mu)_{ij} = \delta_{ij} \partial_\mu + i g_s \sum_a \frac{\lambda_{i,j}^a}{2} A_\mu^a, \quad (76)$$

with g_s the strong coupling constant, f_{abc} the $SU(3)$ structure constants, and λ_i ($i = 1, \dots, 8$) the generators of $SU(3)$ (which can be taken to be the eight traceless Gell-Mann matrices). Note also that ψ_q^i is the free-field Dirac spinor representing a quark of colour i and flavour q and the A_μ^a ($a = 1, \dots, 8$) are the eight gluon fields. As is well known, QCD and non-Abelian gauge theories possess the property of asymptotic freedom: $\alpha_s \equiv g_s^2/4\pi$ obeys the renormalization-group equation (RGE) that determines its evolution as a function of the effective scale Q :

$$Q \frac{d\alpha_s}{dQ} = 2\beta_0 \alpha_s + \dots, \quad (77)$$

where

$$\beta_0 = 11 - \frac{2}{3}n_q \quad (78)$$

and n_q is the number of quark flavours with masses $\ll Q$. In addition to (76), which specifies QCD at the perturbative level, its full specification of its vacuum at the non-perturbative level requires an additional angle parameter, θ_{QCD} , that violates both parity P and CP [15]².

1.4 Parameters of the Standard Model

The transformation from being one of the possible explanations of electromagnetic, weak and strong phenomena into a description in outstanding agreement with experiments is reflected in the dozens of electroweak precision measurements available today [13, 16, 17]. These are sensitive to quantum corrections at and beyond the one-loop level, which are essential for obtaining agreement with the data. The calculations of these corrections rely upon the renormalizability (calculability) of the SM³, and depend on the masses of heavy virtual particles, such as the top quark and the Higgs boson and possibly other particles beyond the SM. The consistency with the data may be used to constrain the masses of these particles.

Many of these observables have quadratic sensitivity to the mass of the top quark, e.g.,

$$s_W^2 \equiv 1 - m_W^2/m_Z^2 \ni -\frac{2\alpha}{16\pi \sin^2(\theta_W)} \frac{m_t^2}{m_Z^2}. \quad (79)$$

This effect was used before the discovery of the top quark to predict successfully its mass [18], and the consistency of the prediction with experiment can be used to constrain possible new physics beyond the SM, particularly mass-squared differences between isospin partner particles, that would contribute analogously to (79). Many electroweak observables are also logarithmically sensitive to the mass of the Higgs boson, e.g.,

$$s_W^2 \ni \frac{5\alpha}{24\pi} \ln \left(\frac{m_H^2}{m_W^2} \right) \quad (80)$$

²The upper limit on the electric dipole moment of the neutron tells us that $|\theta_{QCD}| < \mathcal{O}(10^{-9})$ [13].

³A crucial aspect of this is cancellation of anomalous triangle diagrams between quarks and leptons, which may be a hint of an underlying Grand Unified Theory — see Lecture 4.

when $m_H \gg m_W$. If there were no Higgs boson, or nothing to do its job⁴, radiative corrections such as (80) would diverge, and the SM calculations would become meaningless. Two examples of precision electroweak observables, namely the coupling of the Z^0 boson to leptons and the mass of the W boson, are shown in Fig. 2.

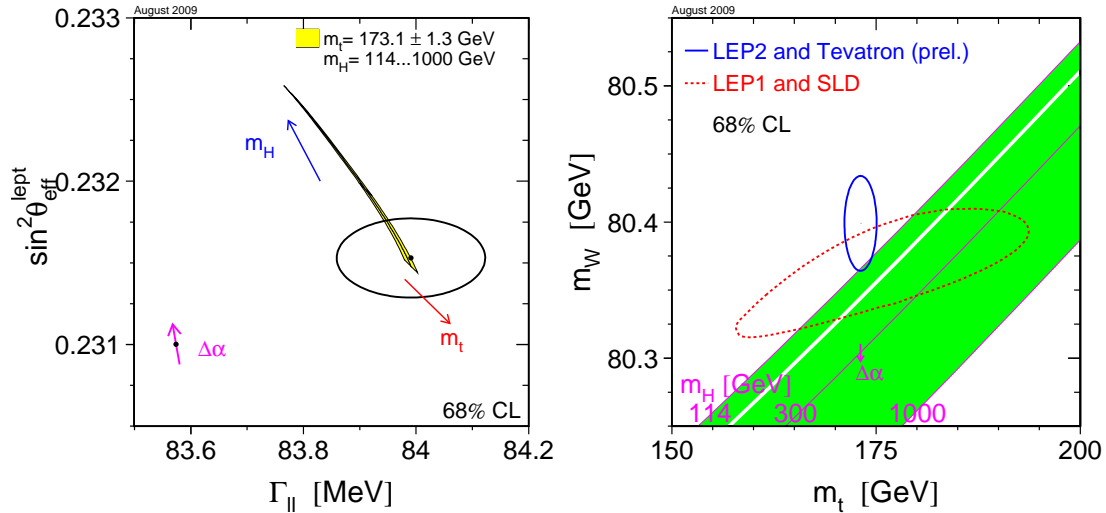

Fig. 2: Left: LEP and SLD measurements of $\sin^2 \theta_W$ and the leptonic decay width of the Z^0 , Γ_{ll} , compared with the SM prediction for different values of m_t and m_H . Right: The predictions for m_t and m_W made in the SM using LEP1 and SLD data (dotted mango-shaped contour) for different values of m_H , compared with the LEP2 and Tevatron measurements (ellipse). The arrows show the additional effects of the uncertainty in the value of α_{em} at the Z^0 peak [16].

Table 2 and Fig. 1.4 [17] compare the predicted (fitted) and experimentally measured values for several parameters of the Standard Model; the agreement is usually better than 1σ . This is a remarkable success for a theory that, as we have seen, can be written down in only a few lines.

The agreement of the precision electroweak observables with the SM can be used to predict m_H , just as it was used previously to predict m_t . Since the early 1990s [19], this method has been used to tighten the vise on the Higgs, providing ever-stronger indications that it is probably relatively light, as hinted in Fig. 4. The latest estimate of the Higgs mass is [16]

$$m_H = 89_{-26}^{+35} \text{ GeV}. \quad (81)$$

Although the central value is somewhat below the lower limit of 114.4 GeV set by direct searches at LEP [20], there is consistency at the 1σ level, and no significant discrepancy. *A priori*, the relatively light mass range (81) suggests that the Higgs boson interacts relatively weakly, with a small quartic coupling λ , though there is no theoretical consensus on this: see the discussion in the next Lecture.

This success is very impressive. However, our rejoicing is muted by the fact that to specify the SM we need at least 19 input parameters in order to calculate physical processes, namely:

- three coupling parameters, which we can choose to be the strong coupling constant, α_s , the fine structure constant, α_{em} , and the weak mixing angle, $\sin^2(\theta_W)$;
- two parameters that specify the shape of the Higgs potential, μ^2 and λ (or, equivalently, m_H and m_W or m_Z);
- six quark masses (or the six Yukawa couplings for the quarks);

⁴See Lecture 2 for a discussion of possible alternatives.

Table 2: Fit and experimental values of some SM quantities, as obtained using the `Gfitter` package [17]. For all the observables listed, except A_l (LEP) and A_l (SLD), the fit values shown are the results of ‘complete fits’, i.e., the results of using all the inputs, including the input value of the parameter that is being fit, to calculate the result. For the two exceptions, the fit values shown were calculated using all inputs except their own. Consult [17] for a description of each observable.

Parameter	Input value	Fit value
M_Z [GeV]	91.1875 ± 0.0021	91.1876 ± 0.0021
Γ_Z [GeV]	2.4952 ± 0.0023	2.4956 ± 0.0015
σ_{had}^0	41.540 ± 0.037	41.478 ± 0.014
R_l^0	20.767 ± 0.025	20.741 ± 0.018
$A_{\text{FB}}^{0,l}$	0.0171 ± 0.0010	0.01624 ± 0.0002
A_l (LEP)	0.1465 ± 0.0033	0.1473 ± 0.0009
A_l (SLD)	0.1513 ± 0.0021	$0.1465^{+0.0007}_{-0.0010}$
$\sin^2 \phi_{\text{eff}}^l(Q_{\text{FB}})$	0.2324 ± 0.0012	$0.23151^{+0.00010}_{-0.00012}$
$A_{\text{FB}}^{0,c}$	0.0707 ± 0.0035	0.0737 ± 0.0005
$A_{\text{FB}}^{0,b}$	0.0992 ± 0.0016	$0.1032^{+0.0007}_{-0.0006}$
A_c	0.670 ± 0.027	$0.6679^{+0.00042}_{-0.00036}$
A_b	0.923 ± 0.020	$0.93463^{+0.00007}_{-0.00008}$
R_c^0	0.1721 ± 0.0030	0.17225 ± 0.00006
R_b^0	0.21629 ± 0.00066	0.21577 ± 0.00005
$\Delta\alpha_{\text{had}}^{(5)}(M_Z^2)$	2768 ± 22	2764^{+22}_{-21}
M_W [GeV]	80.399 ± 0.023	$80.371^{+0.008}_{-0.011}$
Γ_W [GeV]	2.098 ± 0.048	2.092 ± 0.001
\overline{m}_c [GeV]	1.25 ± 0.09	1.25 ± 0.09
\overline{m}_b [GeV]	4.20 ± 0.07	4.20 ± 0.07
m_t [GeV]	173.1 ± 1.3	173.6 ± 1.2

- four parameters (three mixing angles and one weak CP-violating angle) for the Cabibbo-Kobayashi-Maskawa matrix [see Eq. (93) below];
- three charged-lepton masses (or the corresponding Yukawa couplings);
- one parameter to allow for non-perturbative CP violation in QCD, θ_{QCD} .

Moreover, because we now know that neutrinos have mass and that they mix (see, e.g., [21, 22]), the Standard Model must be extended to incorporate this fact. Therefore, we also need to specify three neutrino masses and three mixing angles plus a CP-violating phase for the neutrino mixing matrix, bringing the grand total to 26 parameters. Additionally, if neutrinos turn out to be Majorana particles, so that they are their own antiparticles, two more CP-violating phases need to be specified. Notice that at least 20 of the parameters relate to flavour physics.

Many of the ideas for physics beyond the SM that are discussed later have been motivated by attempts to reduce the number of its parameters, or understand their origins, or at least to make them seem less unnatural, as discussed in subsequent Lectures.

1.5 Bounds on the Standard Model Higgs boson mass

1.5.1 Upper bounds from unitarity

As already emphasized, if there were no Higgs boson, and nothing analogous to replace it, the Standard Model would not be a calculable, renormalizable theory. This incompleteness is reflected in the behaviours of physical quantities as the Higgs mass increases. The most basic example of this is W^+W^-

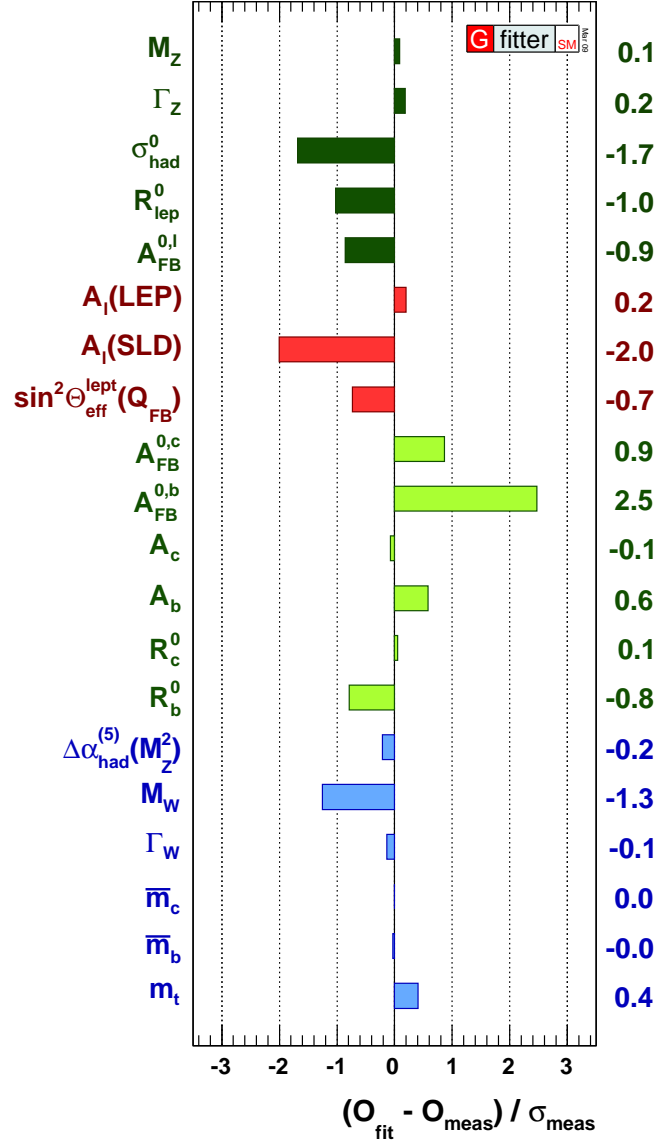

Fig. 3: Comparison between direct measurements and the results of a fit using the Gfitter package [17]

scattering [23], whose high-energy s -wave amplitude grows with m_H :

$$T \sim -\frac{4G_F}{\sqrt{2}}m_H^2. \quad (82)$$

Imposing the unitarity bound $|T| < 1$, one finds the upper limit $M_H^2 < 4\pi\sqrt{2}/G_F$, which is strengthened to

$$M_H^2 < \frac{8\pi\sqrt{2}}{3G_F} \sim 1 \text{ TeV}^2 \quad (83)$$

when one makes a coupled analysis including the $Z^0 Z^0$ channel.

A related effect is seen in the behaviour of the quartic self-coupling λ of the Higgs field. Like any of the Standard Model parameters, λ is subject to renormalization *via* loop corrections. Loops of fermions, most importantly the top quark, tend to *decrease* λ as the renormalization scale Λ increases,

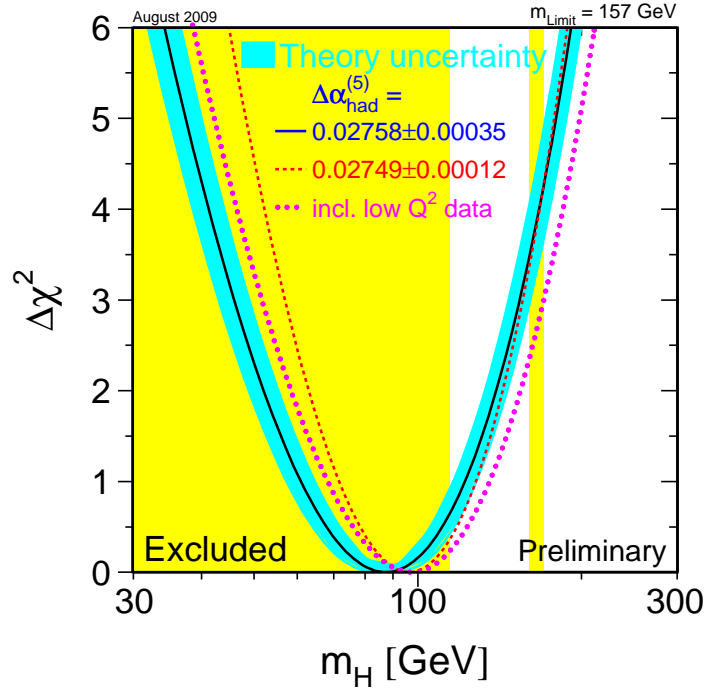

Fig. 4: The χ^2 likelihood function for m_H in a global electroweak fit. The blue band around the (almost) parabolic solid curve represents the theoretical uncertainty: the other curves indicate the effects of different calculations of the renormalization of α_{em} and of including low-energy data. The shaded regions are those excluded by LEP and by the Tevatron [16].

whereas loops of bosons tend to *increase* λ . In particular, if the Higgs mass $\gtrsim m_t$, the positive renormalization due to the Higgs self-coupling itself is dominant, and λ increases uncontrollably with Λ . The larger the value of m_H , the larger the low-energy value of λ , and the smaller the value of Λ at which λ blows up. In general, one should regard the limiting value of Λ , also for smaller m_H , as a scale where novel non-perturbative dynamics must set in. This behaviour is seen in the upper part of Fig. 5, where we see, for example, that if $m_H = 170$ GeV, then $\Lambda \sim 10^{19}$ GeV, whereas if $m_H = 300$ GeV, the coupling λ blows up at a scale $\Lambda \sim 10^6$ GeV. One may ask: under what circumstances does $m_H \sim \Lambda$ itself? The answer is when $m_H \sim 700$ GeV: if the Higgs boson were heavier than this mass, the Higgs self-coupling would blow up at a scale smaller than its mass. In this case, Higgs physics would necessarily be described by some new strongly-interacting theory, cf., the technicolour theories described in Lecture 2.

1.5.2 Lower bounds from vacuum stability

Looking at lower values of m_H in Fig. 5, we see an uneventful range of m_H extending down to $m_H \sim 130$ GeV, where (as far as we know) the SM could continue to be valid all the way to the Planck scale. At lower m_H , there is a band below which the present electroweak vacuum becomes unstable at some scale $\Lambda < 10^{19}$ GeV. For example, if the Higgs is slightly above the present experimental lower limit from LEP, $m_H \sim 115$ GeV, the present electroweak vacuum is unstable against decay into a vacuum with $\langle |\phi| \rangle \sim 10^7$ GeV. This instability is due to the negative renormalization of λ by the top quark, which overcomes the positive renormalization due to λ itself, and drives $\lambda < 0$ ⁵.

If m_H is only slightly below the top band, and above the middle band, it is true that the present

⁵The widths of the boundary bands indicate the uncertainties in these calculations.

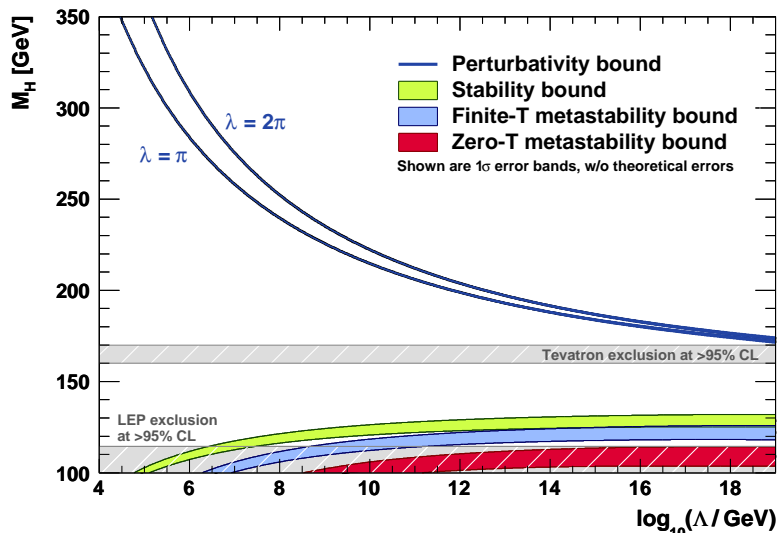

Fig. 5: The scale Λ at which the two-loop RGEs drive the quartic SM Higgs coupling non-perturbative (upper curves), and the scale Λ at which the RGEs create an instability in the electroweak vacuum (lower curves). The widths of the bands reflect the uncertainties in m_t and $\alpha_s(m_Z)$ (added quadratically). The perturbativity upper bound (sometimes referred to as ‘triviality’ bound) is given for $\lambda = \pi$ (lower bold line [blue]) and $\lambda = 2\pi$ (upper bold line [blue]). Their difference indicates the theoretical uncertainty in this bound. The absolute vacuum stability bound is displayed by the light shaded [green] band, while the less restrictive finite-temperature and zero-temperature metastability bounds are medium [blue] and dark shaded [red], respectively. The grey hatched areas indicate the LEP [20] and Tevatron [24] exclusion domains. Figure taken from [25].

electroweak vacuum is in principle unstable against decay into a state with $\langle |\phi| \rangle > \Lambda$, but it would not have decayed during the conventional thermal expansion of the Universe at finite temperatures. Below the middle band but above the lowest band, the vacuum would have decayed to a correspondingly large value of $\langle |\phi| \rangle$ at some finite temperature, but its present-day (low-temperature) lifetime is longer than the age of the Universe. Below the lowest band, the lifetime for decay to a vacuum with $\langle |\phi| \rangle > \Lambda$ would be less than the present age of the Universe at low temperatures, and we should really watch out!

In fact, as we see shortly, such low values of m_H are almost excluded by LEP searches for the SM Higgs boson, as also seen in Fig. 5.

One could in principle avoid this vacuum instability by introducing some new physics at an energy scale $< \Lambda$: what type of physics [26]? One needs to overcome the negative effects of renormalization of λ by loops with the top quark circulating. The sign of renormalization could be reversed by loops with some boson circulating, potentially restoring the stability of the electroweak vacuum. However, then one should consider the renormalization of the quartic coupling between the Higgs and the new boson. It turns out that the renormalization of this coupling is in turn very unstable, and that the best way to stabilize this coupling would be to introduce a new fermion.

These new scalars and fermions look very much like the partners of the top quark and Higgs bosons, respectively, that are predicted by supersymmetry [26]. In Lecture 3 we will study in more detail the renormalization of mass and vacuum parameters in a supersymmetric theory.

1.5.3 Results from searches at LEP and the Tevatron

As seen in Fig. 2, searches for the reaction $e^+e^- \rightarrow Z^0 + H$ at LEP established a lower limit on the possible mass of a SM Higgs boson [20]:

$$m_H > 114.4 \text{ GeV} \quad (84)$$

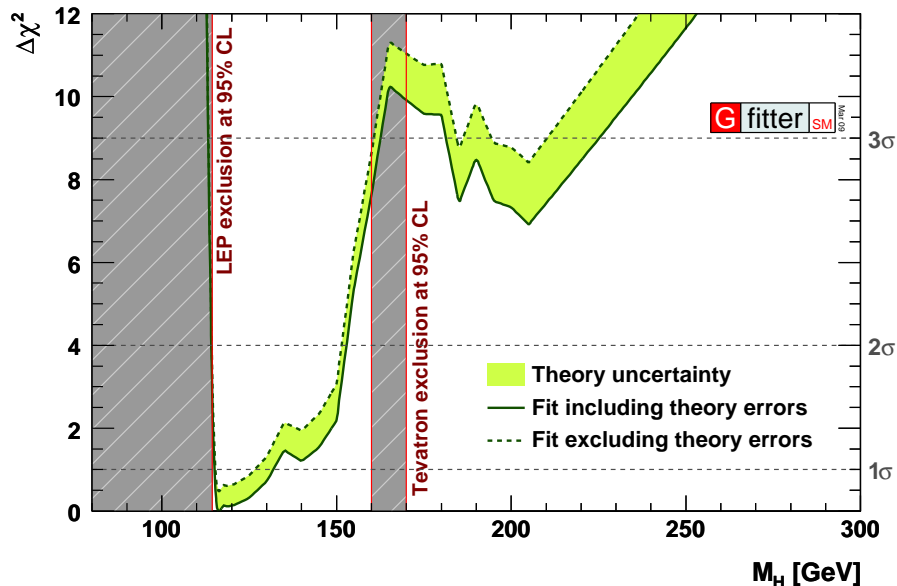

Fig. 6: Dependence on M_H of the $\Delta\chi^2$ function obtained from the global fit of the SM parameters to precision electroweak data [25], excluding (left) or including (right) the results from direct searches at LEP and the Tevatron

at the 95% confidence level. The lower limit (84) is somewhat higher than the central value of the SM Higgs mass preferred by the global precision electroweak fit (81), but there is no significant tension between these two pieces of information. Figure 6 shows the χ^2 likelihood function obtained by combining the LEP search and the global electroweak fit. At the 95% confidence level, one finds [20]

$$m_H < 157 \text{ GeV}, 186 \text{ GeV}, \quad (85)$$

depending whether one uses precision electroweak data alone, or includes also the lower limit (84) from the direct search at LEP. The χ^2 function obtained by combining the LEP limit (84) with the precision electroweak fit is shown in Fig. 6. Notice the little blip at $m_H \sim 115$ GeV, reflecting the hint of a signal found in the last run at the highest LEP energies: this was only at the 1.7- σ level, insufficient to claim any evidence.

Searches at the Fermilab Tevatron collider have recently started to exclude a region of mass for the SM Higgs boson, as also seen in Figs. 2, 5 and 6. At the time of writing, these searches exclude [24]

$$163 \text{ GeV} < m_H < 166 \text{ GeV} \quad (86)$$

at the 95% confidence level, as seen in Fig. 7. At smaller masses, the Tevatron 95% confidence level upper limit on Higgs production and decay is only a few times bigger than the SM expectations, and the integrated luminosity is expected to double over the next couple of years.

Figure 6 also includes the effect on the χ^2 likelihood function of combining the Tevatron search with the global electroweak fit and the LEP search. We see from this that the ‘blow-up’ region $m_H > 180$ GeV is strongly disfavoured: above the 99% confidence level if the Tevatron data are included, compared with 96% if they are dropped [25]. The combination of all the data yields a 68% confidence level range [17]

$$m_H = 116_{-1.3}^{+16} \text{ GeV}. \quad (87)$$

The Tevatron is expected to continue running until late 2011, accumulating $\mathcal{O}(10)$ /fb of integrated luminosity. That could be sufficient to exclude a SM Higgs boson over all the mass range between (84) and (86), which would exclude all the preferred range (85) — a very intriguing possibility! Alternatively, perhaps the Tevatron will find some evidence for a Higgs boson with a mass within this range?

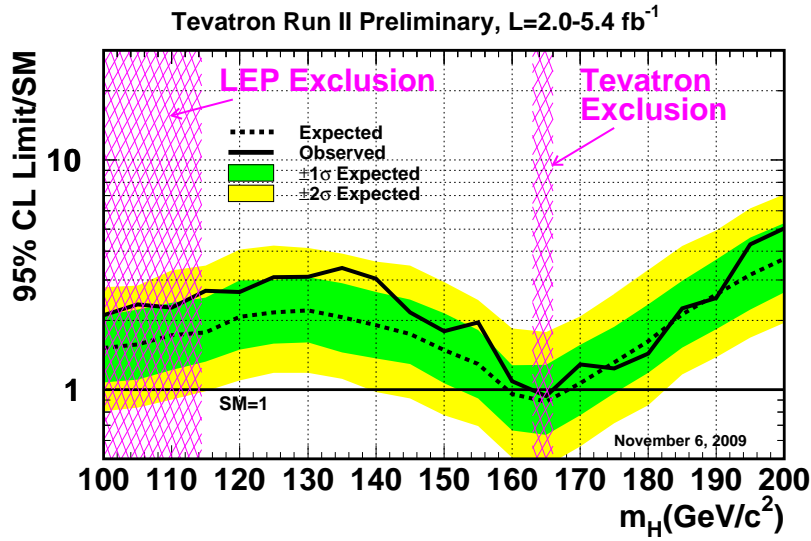

Fig. 7: Combined 95% confidence level upper limit from searches by CDF and D0 for the Higgs boson at the Tevatron collider [24], compared with the SM expectation

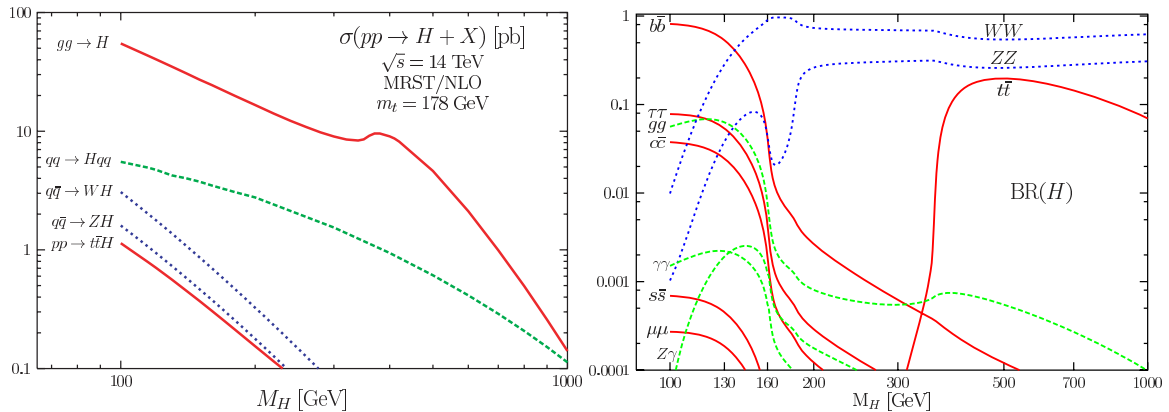

Fig. 8: Left: the dominant mechanisms for producing a SM Higgs boson at the LHC at 14 TeV, and right: the most important branching ratios for a SM Higgs boson, taken from [27]

1.5.4 LHC prospects

The search for the Higgs boson is one of the main raisons d'être of the LHC. Many mechanisms may make important contributions to SM Higgs production at the LHC. If the Higgs boson is relatively light, as suggested above, the dominant production mechanisms are expected to be $gg \rightarrow H$ and $W^+W^- \rightarrow H$, where the W^\pm are radiated off incoming quarks: $q \rightarrow Wq'$.

As already mentioned, the fact that Higgs couplings to other particles are proportional to their masses implies that the Higgs prefers to decay into the heaviest particles that are kinematically accessible. As seen in Fig. 8, this means that a Higgs lighter than ~ 130 GeV prefers to decay into $\bar{b}b$, whereas a heavier Higgs prefers to decay into W^+W^- and Z^0Z^0 . However, couplings to lighter particles can become important under certain circumstances. For example, whilst there is no tree-level coupling to gluons because they are massless, one is induced by loops of heavy particles such as the top quark. For

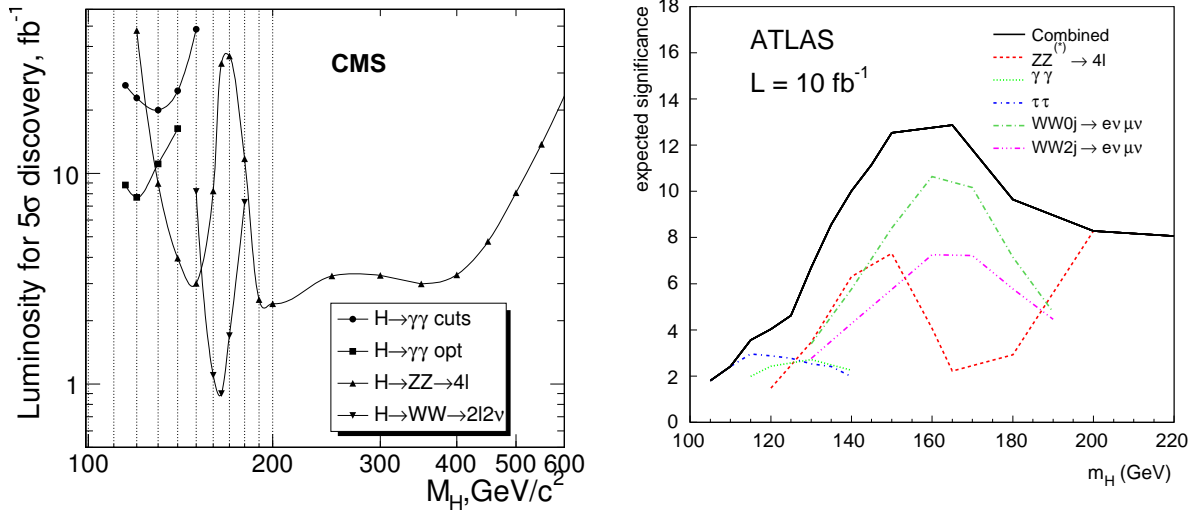

Fig. 9: Left: the amount of integrated luminosity that would be required by CMS [28] to discover a SM Higgs boson as a function of m_H . Right: the significance expected by ATLAS [29] for a SM Higgs boson, assuming 10/fb of data at 14 TeV.

the same reason, there is no tree-level Higgs coupling to photons, but the Higgs boson may decay into $\gamma\gamma$ *via* top and W^\pm loops. Although this decay has a very small branching ratio, it is very distinctive experimentally, and may be detectable at the LHC if the SM Higgs weighs < 130 GeV.

Figure 9 displays estimates of the sensitivities of CMS (left) [28] and ATLAS (right) [29] to a SM Higgs boson. A fraction of an inverse femtobarn per experiment may suffice to exclude a Higgs boson over a large range of masses from ~ 150 GeV to ~ 400 GeV. An integrated luminosity $\sim 1/\text{fb}$ per experiment would be needed to discover a Higgs boson with a mass in a similar range, but more luminosity would be required if $m_H < 150$ GeV. Indeed, a luminosity $\sim 5/\text{fb}$ per experiment would be needed for discovery over all the displayed range of m_H , down to the LEP limit. One way or another, the LHC will be able determine whether or not there is a SM Higgs boson.

1.6 Issues beyond the Standard Model

The Standard Model, however, is not expected to be the final description of the fundamental interactions, but rather an effective low-energy (up to a few TeV) manifestation of a more complete theory.

Some of the outstanding questions in the Standard Model are:

- **How is electroweak symmetry broken?** In other words, how do gauge bosons acquire mass? We have seen that the Standard Model incorporates the Higgs mechanism in the form of a single weak-isospin doublet with a non-zero v.e.v. in order to generate the gauge boson masses, but this is not the only possible way in which the electroweak symmetry can be broken. For instance, there could be more than one Higgs doublet, the Higgs could be a pseudo-Goldstone boson (with a low mass relative to the mass scale of some new interaction) or electroweak symmetry could be broken by a condensate of new particles bound by a new strong interaction. We cover a few of the possibilities in Lecture 2.
- **How do fermions acquire mass?** Electroweak symmetry breaking is a necessary, but not a sufficient, condition to generate the fermion masses. There also needs to be a mechanism that generates the required Yukawa couplings [see Eq. (46)] between the fermions and the (effective) Higgs field. The separation between electroweak symmetry breaking and the generation of fermion masses is made evident in models of dynamical symmetry breaking, such as technicolour (see Section 2),

where the breaking is carried out by the formation of a condensate of particles associated to a new interaction, a process which, while breaking electroweak symmetry and giving masses to the gauge bosons, does not necessarily give masses to the fermions. This situation is resolved by adding new interactions which are responsible for generating the fermion masses. Within the Standard Model, there are no predictions for the values of the Yukawa couplings. Moreover, the values required to generate the correct masses for the three charged leptons and the six quarks span six orders of magnitude, which presumably makes the mechanism for the generation of the couplings highly non-trivial.

- **The hierarchy problem.** Why should the Higgs mass remain low, $m_H \lesssim 1$ TeV, in the face of divergent quantum loop corrections? Following [3], the Higgs mass can be expanded in perturbation theory as

$$m_H^2(p^2) = m_{0,H}^2 + \mathcal{C}g^2 \int_{p^2}^{\Lambda^2} dk^2 + \dots, \quad (88)$$

where $m_{0,H}^2$ is the tree-level (classical) contribution to the Higgs mass squared, g is the coupling constant of the theory, \mathcal{C} is a model-dependent constant, and Λ is the reference scale up to which the Standard Model is assumed to remain valid. The integrals represent contributions at loop level and are apparently quadratically divergent. If there is no new physics, the reference scale is high, like the Planck scale, $\Lambda \sim M_{\text{Pl}} \approx 10^{19}$ GeV or, in Grand Unified Theories (GUTs), $\Lambda \sim M_{\text{GUT}} \approx 10^{15} - 10^{16}$ GeV (see Lecture 4). Clearly, both choices result in large corrections to the Higgs mass. In order for these to be small, there are two alternatives: either the relative magnitudes of the tree-level and loop contributions are finely tuned to yield a net contribution that is small (a feature that is disliked by physicists, but which Nature might have implemented), or there is a new symmetry, like supersymmetry, that protects the Higgs mass, as discussed in Lecture 3.

- **The vacuum energy problem.** The value of the scalar potential, Eq. (31), at the v.e.v. $\langle \phi \rangle_0$ of the Higgs boson is

$$V(\langle \phi^\dagger \phi \rangle_0) = \frac{\mu^2 v^2}{4} < 0. \quad (89)$$

Hence, because the Higgs mass is $m_H^2 = -2\mu^2$, this corresponds to a uniform vacuum energy density

$$\rho_H = -\frac{m_H^2 v^2}{8}. \quad (90)$$

Taking $v = (G_F \sqrt{2})^{-1/2} \approx 246$ GeV for the Higgs v.e.v. and using the current experimental lower bound on the Higgs mass [13], $m_H \gtrsim 114.4$ GeV, we have

$$-\rho_H \gtrsim 10^8 \text{ GeV}^4. \quad (91)$$

On the other hand, if the apparent accelerated expansion of the Universe — originally inferred from observations of type 1A supernovae [30] — is attributed to a non-zero cosmological constant corresponding to $\sim 70\%$ of the total energy density of the Universe [13], the required energy density should be

$$\rho_{\text{vac}} \sim 10^{-46} \text{ GeV}^4, \quad (92)$$

which is at least 54 orders of magnitude lower than the corresponding density from the Higgs field, and of the opposite sign! The character of this dark energy remains unexplained [31, 32], and will probably remain so until we have a full quantum theory of gravity.

- **How is flavour symmetry broken?** Part of the flavour problem in the Standard Model is, of course, related to the widely different mass assignments of the fermions ascribed to the Yukawa

couplings, which also set the mixing angles between flavour and mass eigenstates. Mixing occurs both in the quark and the lepton sectors, the former being parametrized by the Cabibbo–Kobayashi–Maskawa (CKM) matrix and the latter, by the Maki–Nakagawa–Sakata (MNS) matrix. These are complex rotation matrices, and can each be written in terms of three mixing angles and one CP-violating phase (δ) [13]:

$$V = \begin{pmatrix} c_{12}c_{13} & s_{12}c_{13} & s_{13}e^{-i\delta} \\ -s_{12}c_{23} - c_{12}s_{23}s_{13}e^{i\delta} & c_{12}c_{23} - s_{12}s_{23}s_{13}e^{i\delta} & s_{23}c_{13} \\ s_{12}s_{23} - c_{12}c_{23}s_{13}e^{i\delta} & -c_{12}s_{23} - s_{12}c_{23}s_{13}e^{i\delta} & c_{23}c_{13} \end{pmatrix}, \quad (93)$$

where $c_{ij} \equiv \cos(\theta_{ij})$, $s_{ij} \equiv \sin(\theta_{ij})$. While the off-diagonal elements in the quark sector are rather small (of order 10^{-1} to 10^{-3}), so that there is little mixing between quark families, in the lepton sector the off-diagonal elements (except for $[V_{\text{MNS}}]_{e3}$, which is close to zero) are of order 1, so that the mixing between neutrino families is large. The Standard Model does not provide an explanation for this difference.

- **What is dark matter?** The observation that galaxy rotation curves do not fall off with radial distance from the galactic centre can be explained by postulating the existence of a new type of weakly-interacting matter, *dark matter*, in the halos of galaxies. Supporting evidence from the cosmic microwave background (CMB) indicates that the dark matter makes up $\sim 25\%$ of the energy density of the Universe [33]. Dark matter is usually thought to be composed of neutral relic particles from the early Universe. Within the Standard Model, neutrinos are the only candidate massive neutral relics. However, they contribute only with a normalized density of $\Omega_\nu \gtrsim 1.2 (2.2) \times 10^{-3}$ if the mass hierarchy is normal (inverted), or no more than 10% if the lightest mass eigenstate lies around 1 eV, that is, if the hierarchy is degenerate [3]. On top of that, structure formation indicates that dark matter should be cold, i.e., non-relativistic at the time of structure formation, whereas neutrinos would have been relativistic particles. Within the Minimal Supersymmetric extension of the Standard Model (MSSM), the lightest supersymmetric partner, called a *neutralino*, is a popular dark matter candidate [34].
- **How did the baryon asymmetry of the Universe arise?** The antibaryon density of the Universe is negligible, whilst the baryon-to-photon ratio has been determined, using WMAP data ⁶ of the CMB [35] to be

$$\eta = \frac{n_b - \bar{n}_b}{n_\gamma} \simeq \frac{n_b}{n_\gamma} = 6.12 (19) \times 10^{-10}, \quad (94)$$

where n_b , \bar{n}_b , and n_γ are the number densities of baryons, antibaryons, and photons, respectively. The fact that the ratio is not zero is intriguing considering that, in a cosmology with an inflationary epoch, conventional thermal equilibrium processes would have yielded an equal number of particles and antiparticles. In 1967, Sakharov [36] established three necessary conditions (more fully explained in [37]) for the particle–antiparticle asymmetry of the Universe to be generated:

1. violation of the baryon number, B ;
2. microscopic C and CP violation;
3. loss of thermal equilibrium.

Otherwise, the rate of creation of baryons equals the rate of destruction, and no net asymmetry results. In the perturbative regime, the Standard Model conserves B ; however, at the non-perturbative level, B violation is possible through the triangle anomaly [15]. The loss of thermal equilibrium may occur naturally through the expansion of the Universe, and CP violation enters the Standard Model through the complex phase in the CKM matrix [13]. However, the CP violation observed so far, which is described by the Kobayashi–Maskawa mechanism of the Standard

⁶We use here values from the three-year WMAP analysis [35], rather than the five-year analysis [33], in order to be consistent with the values quoted by the Particle Data Group [13] summary tables.

Model, is known to be insufficient to explain the observed value of the ratio η , and new physics is needed. One possible solution lies in leptogenesis scenarios, where the baryon asymmetry is a result of a previously existing lepton asymmetry generated by the decays of heavy sterile neutrinos [38].

- **Quantization of the electric charge.** It is an experimental fact that the charges of all observed particles are simple multiples of a fundamental charge, which we can take to be the electron charge, e . Dirac [39–41] proved that the existence of even a single magnetic monopole (a magnet with only one pole) is sufficient to explain the quantization of the electric charge, but the particle content of the Standard Model (see Table 1) does not include magnetic monopoles. Hence, in the absence of any indication for a magnetic monopole, the explanation of charge quantization must lie beyond the Standard Model. Indeed, so far there has only been one candidate monopole detection event in a single superconducting loop [42], in 1982, and the monopole interpretation of the event has now been largely discounted. One expects monopoles to be very massive and non-relativistic at present, in which case time-of-flight measurements in the low-velocity regime ($\beta \equiv v/c \ll 1$) become important. The best current direct upper limit on the supermassive monopole flux comes from cosmic-ray observations [13]:

$$\Phi_{\text{pole}} < 1.0 \times 10^{-15} \text{ cm}^{-2} \text{sr}^{-1} \text{s}^{-1}, \quad (95)$$

for $1.1 \times 10^{-4} < \beta < 0.1$. An alternative route towards charge quantization is *via* a Grand Unified Theory (GUT) (see Lecture 4). Such a theory implies the existence of magnetic monopoles that would be so massive that their cosmological density would be suppressed to an unobservably small value by cosmological inflation.

- **How to incorporate gravitation?** One of the most obvious shortcomings of the Standard Model is that it does not incorporate gravitation, which is described on a classical level by general relativity. However, the consistency of our physical theories requires a quantum theory of gravity. The main difficulty in building a quantum field theory of gravity is its non-renormalizability. String theory [43] and loop quantum gravity [44] constitute attempts at building a quantized theory of gravity. If one could answer this question, one would surely also be able to solve the dark energy problem. Conversely, solving the dark energy problem presumably requires a complete quantum theory of gravity.

2 Electroweak symmetry breaking beyond the Standard Model

2.1 Theorists are getting cold feet

After so many years, it seems that we will soon know whether a Higgs boson exists in the way predicted by the Standard Model, or not. Closure at last!

Like the prospect of an imminent hanging, the prospect of imminent Higgs discovery concentrates wonderfully the minds of theorists, and many theorists with cold feet are generating alternative models, as prolifically as monkeys on their laptops. These serve the invaluable purpose of providing benchmarks that can be compared and contrasted with the SM Higgs. Experimentalists should be ready to search for reasonable alternatives, already at the Tevatron and also at the LHC once it is up and running, and they should be on the look-out for tell-tale deviations from the SM predictions if a Higgs boson should appear.

Even within the SM with a single elementary Higgs boson, questions are being asked. As discussed in the previous section, within this framework the experimental data seem to favour a light Higgs boson. However, the interpretation of the precision electroweak data has been challenged. Even if one accepts the data at face value, the SM fit may need to take into account non-renormalizable, higher-dimensional interactions that could conspire to permit a heavier SM Higgs boson? In this section, in addition to these possibilities, we explore several mechanisms of electroweak symmetry breaking be-

yond the minimal Higgs, i.e., a single elementary $SU(2)$ Higgs doublet whose potential is arranged to have a non-zero v.e.v.

Any successful model of electroweak symmetry breaking must give masses to the matter fermions as well as the weak gauge bosons. This could be achieved using either a single boson, as in the SM, or two of them, as in the Minimal Supersymmetric extension of the Standard Model (MSSM)⁷, or by some composite of new fermions with new strong interactions that generate a non-zero v.e.v. as in (extended) technicolour models, or by some Higgsless mechanism.

We do know, however, that the energy scale at which EWSB must occur is $\mathcal{O}(1)$ TeV [45]. This scale is set by the decay constant of the three Goldstone bosons that, through the Higgs mechanism, are transformed into the longitudinal components of the weak gauge bosons:

$$F_\pi = \left(G_F \sqrt{2}\right)^{-1/2} \approx 246 \text{ GeV} . \quad (96)$$

If there is any new physics associated to the breaking of electroweak symmetry, it must occur near this energy scale. Another way to see how this energy scale emerges is to consider s -wave WW scattering. In the absence of a direct-channel Higgs pole, this amplitude would violate the unitarity limit at an energy scale ~ 1 TeV (82).

It is the scale of 1 TeV, and the typical values of QCD and electroweak cross sections at this energy, $\sigma \simeq 1 \text{ nb} - 1 \text{ fb}$, that set the energy and luminosity requirements of the LHC: $\sqrt{s} = 14$ TeV and $\mathcal{L} = 10^{34} \text{ cm}^{-2} \text{ s}^{-1}$ for pp collisions [13]. This energy scale is to be contrasted with the energy scale of the other unexplained broken symmetry in the SM, namely flavour symmetry, which is completely unknown: it may lie anywhere from 1 TeV up to the Planck scale, $M_P = 1.22 \times 10^{19}$ GeV.

There are some general constraints that any proposed model of electroweak symmetry breaking must satisfy [46]. First, the model must predict a value of the ρ parameter, Eq. (73), that agrees with the value $\rho \approx 1$ found experimentally. The desired value $\rho = 1$ is found automatically in models that contain only Higgs doublets and singlets, but would be violated in models with scalar fields in larger $SU(2)$ representations. A second constraint comes from the strict upper limits on flavour-changing neutral currents (FCNCs). These are absent at tree level in the minimal Higgs model, a fact that is in general not true in non-minimal models.

2.2 Interpretation of the precision electroweak data

It is notorious that the two most precise measurements at the Z^0 peak, namely the asymmetries measured with leptons (particularly $A_\ell(SLD)$) and hadrons (particularly $A_{FB}^{0,b}$), do not agree very well [47], as seen in Table 2 and Fig. 1.4⁸. Within the SM, they favour different values of m_H , around 40 and 500 GeV, respectively, as seen in Fig. 10. Most people think that this discrepancy is just a statistical fluctuation, since the total χ^2 of the global electroweak fit is acceptable ($\chi^2 = 17.3$ for 13 d.o.f., corresponding to a probability of 18% [16]), but it may also reflect the existence of an underestimated systematic error. However, if there were a big error in $A_{FB}^{0,b}$, the preferred value of m_H would be pulled uncomfortably low by the other data, whereas if there was a big error in the interpretation of the leptonic data m_H would be pulled towards much higher values. On the other hand, if we take both pieces of data at face value, perhaps the discrepancy is evidence for new physics at the electroweak scale. In this case there would be no firm basis for the prediction of a light Higgs boson, which is based on a Standard Model fit, and no fit value of m_H could be trusted?

⁷We leave the treatment of the Higgs sector within the MSSM for a later section.

⁸Another anomaly is exhibited by the NuTeV data on deep-inelastic $\nu - N$ scattering [48], but this is easier to explain away as due to our lack of understanding of hadronic effects.

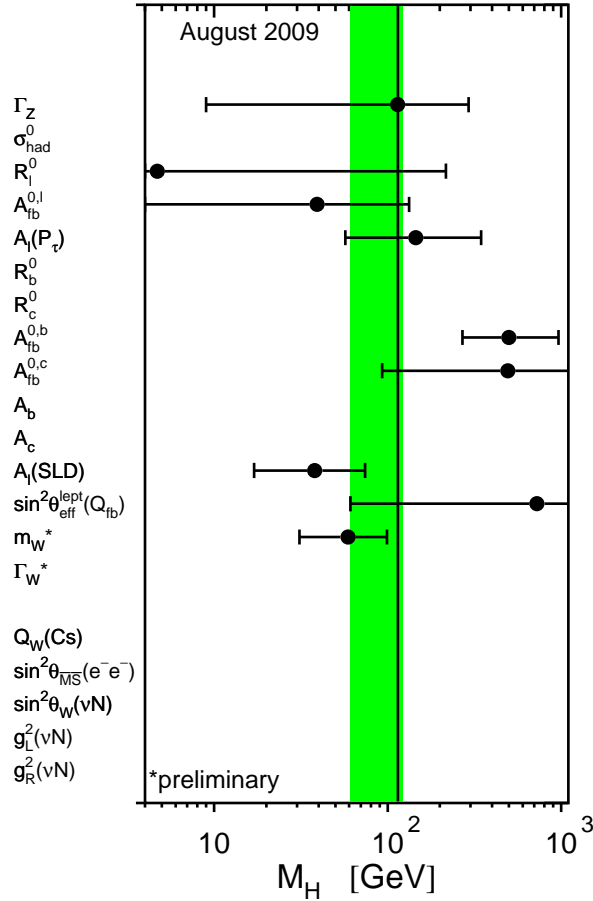

Fig. 10: The 68% confidence level ranges for m_H that are indicated by various individual electroweak measurements [16]

2.3 Higher-dimensional operators within the SM

The Standard Model should be regarded simply as an effective low-energy theory, to be embedded within some more complete and satisfactory theory. Therefore, one should anticipate that the renormalizable dimension-four interactions of the SM could be supplemented by higher-dimensional operators of the general form:

$$\mathcal{L}_{eff} = \mathcal{L}_{SM} + \sum_i \frac{c_i}{\Lambda_i^p} \mathcal{O}_i^{4+p}, \quad (97)$$

where Λ_i is a scale at which the supplementary interaction \mathcal{O}_i^{4+p} of dimension $4 + p$ appears to be generated. A global fit to the precision electroweak data suggests that, if the Higgs is indeed light, the coefficients of these additional interactions are small:

$$\Lambda_i > \mathcal{O}(10) \text{ TeV} \quad (98)$$

for $c_i = \pm 1$. It is then a problem to understand the ‘little hierarchy’ between the electroweak scale and Λ_i .

However, conspiracies are in principle possible, which could allow m_H to be large, even if one takes the precision electroweak data at face value [49]. Examples are shown in Fig. 11, where one sees corridors of allowed parameter space extending up to a heavy Higgs mass, if $\Lambda_i \ll 10$ TeV. A theory that predicts a heavy Higgs boson but remains consistent with the precision electroweak data should predict a correlation of the type seen in Fig. 11. At the moment, this may seem unnatural to us, but Nature may

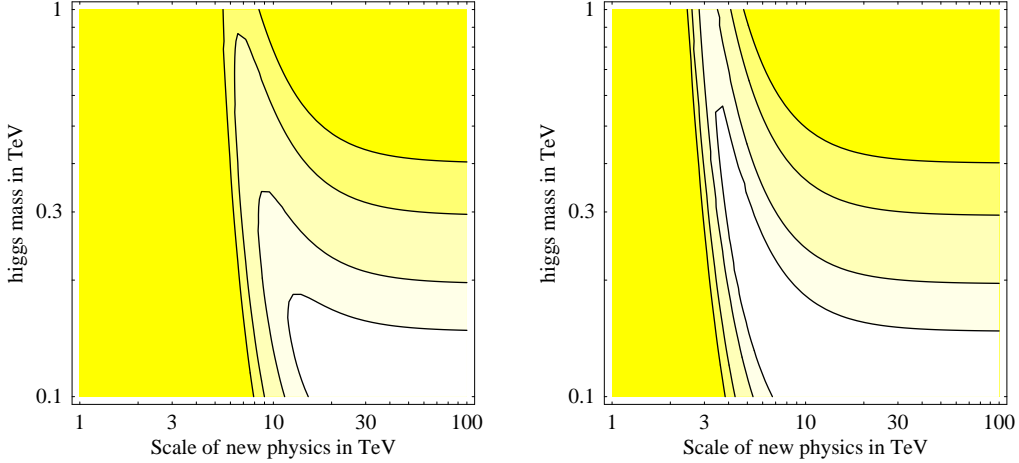

Fig. 11: The 68%, 90%, 99% and 99.9% confidence levels fit for global electroweak fits including two different types of higher-dimensional operators, demonstrating that they might conspire with a relatively heavy Higgs boson to yield an acceptable fit [49]

know better. In any case, any theory beyond the SM must link the value of m_H and the scales of these higher-dimensional effective operators in some way.

2.4 Little Higgs

One way to address the ‘little hierarchy problem’ and explain the lightness of the Higgs boson (if it is light) is by treating it as a pseudo-Goldstone boson corresponding to a spontaneously broken approximate global symmetry of a new strongly-interacting sector at some higher mass scale, the ‘little Higgs’ scenario [50]. Such a theory would work by analogy with the pions in QCD, which have masses far below the generic mass scale of the strong interactions ~ 1 GeV.

If the Higgs is a pseudo-Goldstone boson, its mass is protected from acquiring quadratically-divergent loop corrections [51]. This occurs as a result of the particular manner in which the gauge and Yukawa couplings break the global symmetries: more than one coupling must be turned on at a time in order for the symmetry to be broken, a feature known as ‘collective symmetry breaking’ [52, 53]. As a consequence, the quadratic divergences that would normally appear in the SM are cancelled by new particles, sometimes in unexpected ways. For example, the top-quark loop contribution to the Higgs mass-squared has the general form

$$\delta m_{H,top}^2(SM) \sim (115 \text{ GeV})^2 \left(\frac{\Lambda}{400 \text{ GeV}} \right)^2. \quad (99)$$

As illustrated in Fig. 12, in little Higgs models this is cancelled by the loop contribution due to a new heavy top-like quark T with charge $+2/3$ that is a singlet of $SU(2)_L$, leaving a residual logarithmic divergence:

$$\delta m_{H,top}^2(LH) \sim \frac{6G_F m_t^2}{\sqrt{2}\pi^2} m_T^2 \log \frac{\Lambda}{m_T}. \quad (100)$$

Analogously, the quadratic loop divergences associated with the gauge bosons and the Higgs boson of the Standard Model are cancelled by loops of new gauge bosons and Higgs bosons in little Higgs models.

The net result is a spectrum containing a relatively light Higgs boson and other new particles that may be somewhat heavier:

$$M_T < 2 \text{ TeV} \left(\frac{m_H}{200 \text{ GeV}} \right)^2, M_{W'} < 6 \text{ TeV} \left(\frac{m_H}{200 \text{ GeV}} \right)^2, M_{H^{++}} < 10 \text{ TeV}. \quad (101)$$

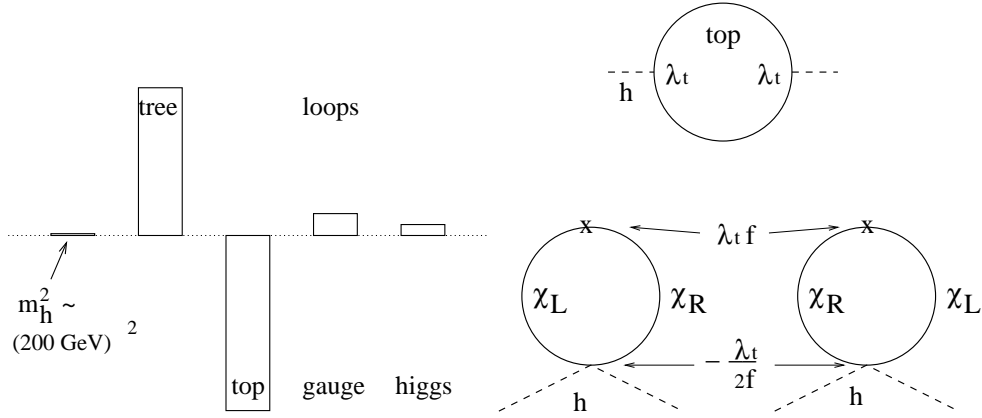

Fig. 12: Left: If the Standard Model Higgs boson weighs around 200 GeV, the top-quark loop contribution to its physical mass (calculated here with a loop momentum cutoff of 10 TeV) must cancel delicately against the tree-level contribution. Right: In ‘little Higgs’ models, the top-quark loop is cancelled by loops containing a heavier charge-2/3 quark [50].

The extra T quark, in particular, should be accessible to the LHC. In addition, there should be more new strongly-interacting physics at some energy scale at or above 10 TeV, to provide the ultra-violet completion of the theory.

2.5 Technicolour

Little Higgs models are particular examples of composite Higgs models, of which the prototypes were technicolour models [54, 55]. In these models, electroweak symmetry is broken dynamically, by the introduction of a new non-Abelian gauge interaction [56–58] that becomes strong at the TeV scale. The building blocks are massless fermions called technifermions and new force-carrying fields called technigluons. As in the SM, the left-handed components of the technifermions are assigned to electroweak doublets, while the right-handed components form electroweak singlets, and both components carry hypercharge. At $\Lambda_{\text{EW}} \sim 1$ TeV the technicolour coupling becomes strong, which leads to the formation of condensates of technifermions with v.e.v.’s

$$\langle \phi \rangle = \langle \bar{f}_L f_R \rangle \equiv v. \quad (102)$$

Because the left-handed technifermions carry electroweak quantum numbers, but the right-handed ones do not, the formation of this technicondensate breaks electroweak symmetry.

The massless technifermions have the chiral symmetry group

$$G_\chi = SU(2N_D)_L \otimes SU(2N_D)_R \supset SU(2)_L \otimes SU(2)_R, \quad (103)$$

where N_D is the number of technifermion doublets. When the condensate forms, this large global symmetry is broken down to

$$S_\chi = SU(2N_D) \supset SU(2)_V, \quad (104)$$

where V refers to the vector combination of left and right currents, and $4N_D^2 - 1$ massless Goldstone bosons appear, with decay constant F_π^{TC} . Similarly to the Higgs mechanism in the SM, three of these bosons are ‘eaten’ and become the longitudinal components of the W^\pm and Z^0 weak bosons, which acquire masses [45]

$$m_W = \frac{g}{2} \sqrt{N_D} F_\pi^{\text{TC}}, \quad m_Z = \frac{1}{2} \sqrt{g^2 + g'^2} \sqrt{N_D} F_\pi^{\text{TC}} = \frac{m_W}{\cos(\theta_W)}. \quad (105)$$

The scale Λ_{TC} at which technicolour interactions become strong is related to the magnitude of electroweak symmetry breaking, namely to the weak scale, by:

$$\Lambda_{\text{TC}} = \text{few} \times F_{\pi}^{\text{TC}}, F_{\pi}^{\text{TC}} = F_{\pi} / \sqrt{N_D}, \quad (106)$$

where $F_{\pi} = v \approx 246$ GeV. The breaking of the chiral symmetry in technicolour is reminiscent of chiral symmetry in QCD, which provides a working precedent for the model⁹. Technicolour guarantees $\rho = m_W^2 / (m_Z^2 \cos^2(\theta_W)) = 1 + \mathcal{O}(\alpha)$ through a custodial $SU(2)_R$ flavour symmetry in G_{χ} [45], which is traceable to the quantum numbers assigned to the technifermions.

Dynamical symmetry breaking addresses the problem of quadratic divergences in the Higgs mass-squared, such as (99), by introducing a composite Higgs boson that ‘dissolves’ at the scale Λ_{TC} . In this way, it makes loop corrections to the electroweak scale ‘naturally’ small. Moreover, technicolour has a plausible mechanism for stabilizing the weak scale far below the Planck scale. The idea is that technicolour, being an asymptotically-free theory, couples weakly at very high energies $\sim 10^{16}$ GeV, and then evolves to become strong at lower energies ~ 1 TeV [54]. However, writing down an explicit GUT scenario based on this scenario has proved elusive.

As described above, the simplest technicolour models could provide masses for the gauge bosons W^{\pm} and Z^0 , but not to the matter fermions. Additions to technicolour could allow for quark and lepton masses by introducing new interaction with technifermions, as in ‘extended technicolour’ models [55, 60]. However, these had severe problems with flavour-changing neutral interactions [61] and a proliferation of relatively light pseudo-Goldstone bosons that have not been seen by experiment [62].

Moreover, a generic problem with technicolour models is presented by the global electroweak fit discussed in the first Lecture. The preference within the SM for a relatively light Higgs boson (81) may be translated into constraints on the possible vacuum polarization effects due to generic new physics models. QCD-like technicolour models have many strongly-interacting dynamical scalar resonances in the TeV range, e.g., a scalar analogous to the σ meson of QCD that corresponds naively to a relatively heavy Higgs boson, which is disfavoured by the data [63]. Such a model can be reconciled with the electroweak data only if some other effect is postulated to cancel the effects of its large mass. One strategy for evading this problem is offered by ‘walking technicolour’ theories [64], where the coupling strength evolves slowly, i.e., walks. However, the loss of the close analogy with QCD makes it more difficult to calculate so reliably in such models: lattice techniques may come to the rescue here.

2.6 Interpolating models

So far, we have examined two extreme scenarios: the orthodox interpretation of the SM in which the Higgs is elementary and relatively light, and hence interacts only weakly, and strongly-coupled models exemplified by technicolour. The weakly-coupled scenario would require additional TeV-scale particles to stabilize the Higgs mass by cancelling out the quadratic divergences such as (99). A prototype for such models is provided by supersymmetry, as discussed in the next Lecture. On the other hand, strongly-coupled models such as technicolour introduce many resonances that are required by unitarity and generate important contributions to the oblique radiative corrections, e.g., a vector resonance ρ in W^+W^- scattering would induce

$$\delta\rho \sim \frac{m_W^2}{m_{\rho}^2} \quad (107)$$

where ρ was defined in (73), and the experimental upper limit $|\rho| < 10^{-3}$ at the 95% confidence level imposes $m_{\rho} > 2.5$ TeV.

One way to interpolate between these two extreme scenarios, and provide a basis for determining how far from the light-SM-Higgs scenario the data permit us to go, is to consider models in which

⁹The condensation phenomenon also occurs in solid-state physics: dynamical symmetry breaking in superconductors is achieved by the formation of Cooper pairs [59], which are condensates of electron pairs with charge $-2e$.

the unitarization of the W^+W^- scattering amplitude is shared between a light Higgs boson with modified couplings and a vector resonance with mass m_ρ and coupling g_ρ , whose relative importance is parametrized by the combination

$$\xi \equiv v \frac{g_\rho}{m_\rho}. \quad (108)$$

The SM is recovered in the limit $\xi \rightarrow 0$, but its decay branching ratios may differ considerably as ξ increases towards the strong-coupling limit $\xi = 1$, as seen in Fig. 13. Thus, one signature for such models at the LHC may be the observation of a Higgs boson with couplings that differ from those of the SM.

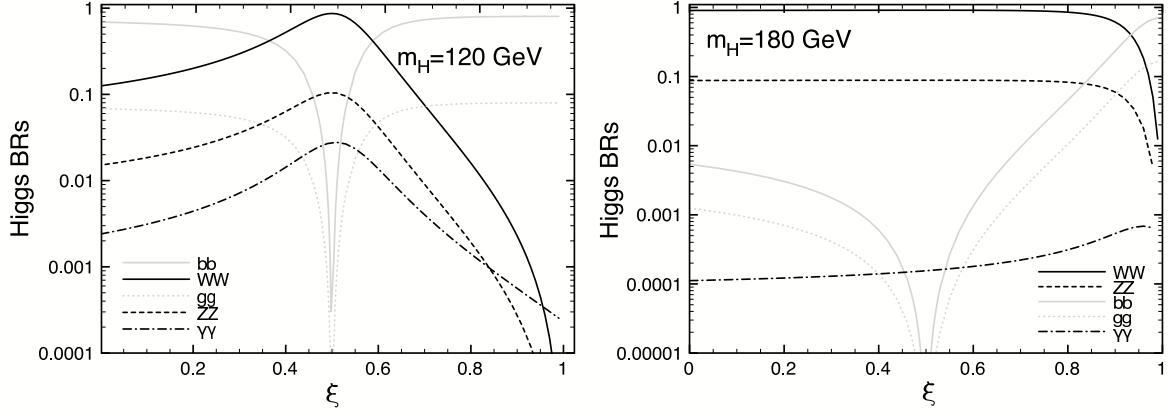

Fig. 13: The dependences of Higgs branching ratios on the parameter ξ (108), for $m_H = 120$ GeV (left) and 180 GeV (right) [65]

Another way to probe such models is to look for effects in $W_L^+W_L^+$ scattering. Unfortunately, at the LHC the W^\pm bosons that are flashed off from incoming energetic quarks: $q \rightarrow Wq'$ have predominantly transverse polarizations, so that $\sigma(W_T^+W_T^+ \rightarrow W_T^+W_T^+) \gg \sigma(W_L^+W_T^+ \rightarrow W_T^+LW_T^+)$ and $\sigma(W_L^+W_L^+ \rightarrow W_L^+W_L^+)$ for all $m_{W^+W^+}$ in the SM, and there is an accidental very small factor [65]:

$$\frac{d\sigma^{LL}/dt}{d\sigma^{TT}/dt} = \frac{1}{2304} \left(\frac{m_{W^+W^+}}{m_W} \right)^4 \xi^2, \quad (109)$$

which implies that, even for $\xi = 1$, $\sigma(W_L^+W_L^+ \rightarrow W_L^+W_L^+) > \sigma(W_T^+W_T^+ \rightarrow W_T^+W_T^+)$ only for $m_{W^+W^+} > 1.2$ TeV, which is unlikely to be accessible at the LHC, as seen in Fig. 14. An alternative possibility for the LHC may be double-Higgs production *via* the reaction $W^+W^- \rightarrow HH$, which may be greatly enhanced as compared with its rate in the SM, as also seen in Fig. 14 — though its observability may be a different matter.

2.7 Higgsless models and extra dimensions

As has already been discussed, if there is nothing like a SM Higgs boson, s -wave WW scattering reaches the unitarity limit at $m_{W^+W^-} \sim 1$ TeV (83). An immediate reaction might be: Who cares? Some non-perturbative strong dynamics will necessarily restore unitarity, even in the absence of a Higgs boson. However, more detailed study in specific models has shown that this strong dynamics is apparently incompatible with the precision data: one needs some perturbative mechanism to break the electroweak symmetry.

How can one break a gauge symmetry? Breaking it explicitly would destroy the renormalizability (calculability) of the gauge theory, whereas breaking the symmetry spontaneously by the v.e.v. of some field everywhere in space does retain the renormalizability (calculability) of the gauge symmetry. But

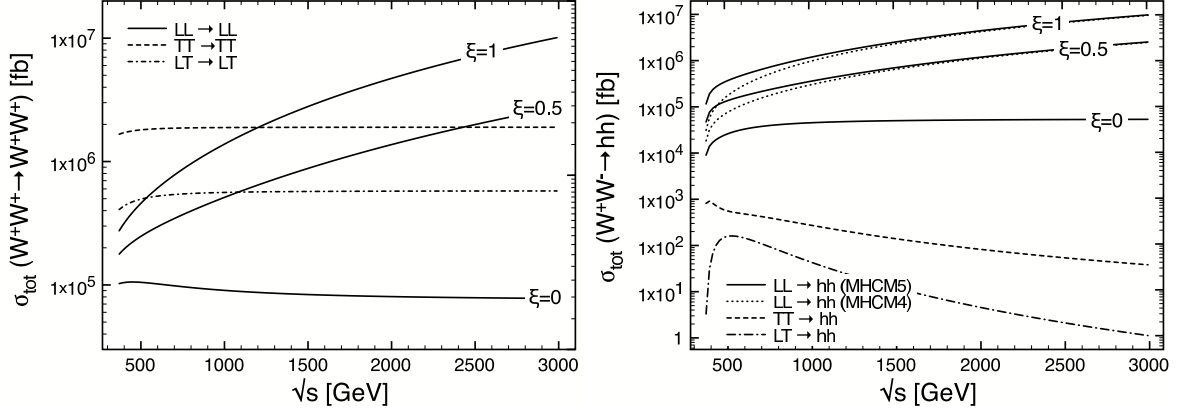

Fig. 14: Left; the cross sections $\sigma(W_T^+ W_T^+ \rightarrow W_T^+ W_T^+)$, $\sigma(W_L^+ W_T^+ \rightarrow W_T^+ L W_T^+)$, and $\sigma(W_L^+ W_L^+ \rightarrow W_L^+ W_L^+)$, as functions of ξ (108). Right: cross sections for double Higgs production [65].

that is the Higgs approach that we are trying to escape: Is there another way? The alternative is to break the electroweak symmetry *via* boundary conditions. This is impossible in conventional 3 + 1-dimensional space-time, because it has no boundaries. However, it becomes an option if we postulate finite-size (small) extra space dimensions [66–68].

To see how this works, let us first consider the particle spectrum in the simplest possible model with one extra dimension compactified on a circle S^1 of radius R with internal coordinate (fifth dimension) y , as illustrated in Fig. 15. In this case, the wave function of a boson ϕ at y and $y + 2\pi R$ must be identified:

$$\phi(y + 2\pi R) = \phi(y), \quad (110)$$

so that one can expand the five-dimensional field as follows:

$$\phi(x, y) = \sum_n \frac{1}{\sqrt{2^{\delta_{n0}} \pi R}} \left(\cos\left(\frac{ny}{R}\right) \phi_n^+(x) + \sin\left(\frac{ny}{R}\right) \phi_n^-(x) \right). \quad (111)$$

The ϕ_n^\pm are the four-dimensional Kaluza–Klein [69, 70] modes of the field, which appear in four dimensions as particles with masses

$$m_n = p_y^n = \frac{n}{R}, \quad (112)$$

and the functions $\cos, \sin(ny/R)$ describe the localizations of these modes along the extra dimension. the lowest-lying mode has a flat wave function ($n = 0$), and the excitations have $n > 0$.

We now consider what happens if we ‘fold’ the circle by identifying $y \sim -y$. Mathematically, this is the simplest *orbifold* S^1/Z_2 , also illustrated in Fig. 15. At the same time as identifying $y \sim -y$, we can also identify the field ϕ up to a sign:

$$\phi(-y) = U\phi(y) : U^2 = 1. \quad (113)$$

This has the effect of projecting out half the Kaluza–Klein wave functions (111). If we choose $U = +1$, we select the even wave functions $\cos(ny/R)$ and hence the Kaluza–Klein modes $\phi_n^+(x)$ whereas, if we choose $U = -1$, we select the odd wave functions $\sin(ny/R)$ and hence the Kaluza–Klein modes $\phi_n^-(x)$. The ‘even’ particles include the massless mode with $n = 0$ whereas all the ‘odd’ particles are massive. The projection U serves to give masses to all the states that are asymmetric.

This mechanism can be extended to break gauge symmetry [66–68]. Let us consider a five-dimensional theory with a gauge field $A_{\mu,5}$, and let us identify it on the orbifold $y \sim -y$ up to a discrete

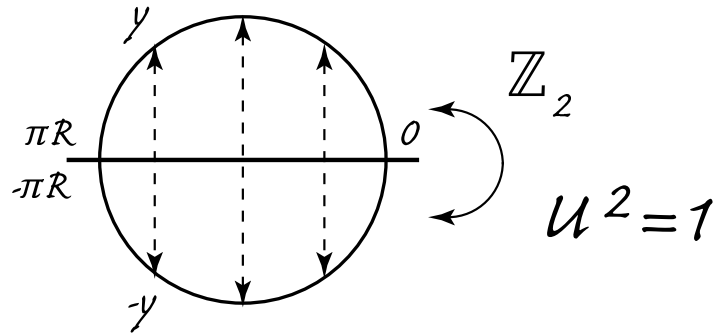

Fig. 15: Compactification on a circle S^1 of radius R with internal coordinate (fifth dimension) y , illustrating the possible orbifolding of this model *via* the identification S^1/Z_2

gauge transformation $U : U^2 = 1$:

$$A_\mu = +UA_\mu(y)U^\dagger, \quad (114)$$

$$A_5 = -UA_5(y)U^\dagger. \quad (115)$$

The gauge symmetry group is broken at the end-points of the orbifold $y = 0, \pi R$: the surviving subgroup is the one that commutes with U , and asymmetric particles acquire masses as described above. In this way, one could imagine breaking $SU(2) \otimes U(1) \rightarrow U(1)$ with a suitable orbifold construction.

It is a general feature of this construction that a vector resonance should appear in WZ scattering, corresponding to the lowest-lying Kaluza–Klein excitation. The production of such a particle at the LHC has been considered in the context of a Higgsless model, and could well be observable, as seen in Fig. 16.

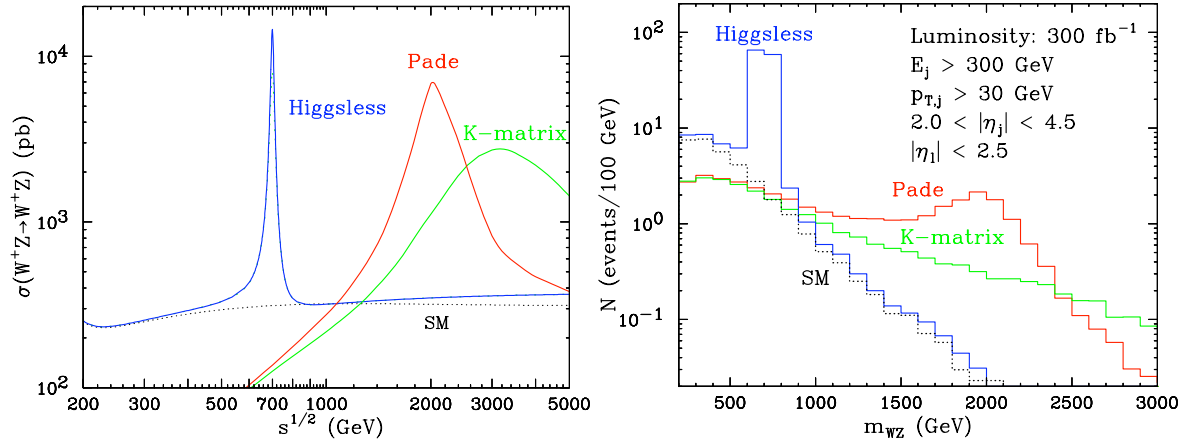

Fig. 16: Left: calculations of the possible modifications of $\sigma(W^+Z^0 \rightarrow W^+Z^0)$. Right: simulations of the possible numbers of events at the LHC [65].

You might wonder whether this type of vector resonance bears any relation to the vector resonances discussed previously in the context of new strong dynamics. The answer is yes: as was first emphasized in the context of string theory, a strong coupling is equivalent to a new compactified dimension, and there is in general a ‘holographic’ relation between four- and five-dimensional theories, the former being considered as boundaries of the five-dimensional ‘bulk’ theory. These ideas enable the strongly-interacting models of electroweak symmetry breaking discussed in this Lecture, and many others, to be related through a unified description à la M-theory [71], as seen in Fig. 17 [72]. The alternative is a weakly-interacting model of electroweak symmetry breaking, which is favoured, naively, by

the indications from precision electroweak data of a light Higgs boson. In the next Lecture we discuss supersymmetry, which is the most developed such alternative.

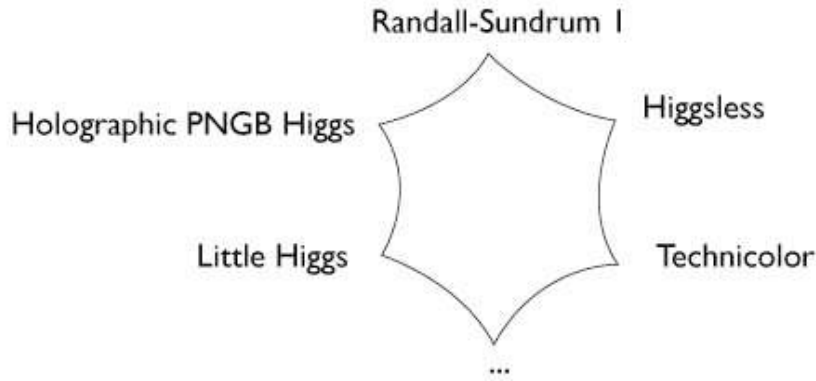

Fig. 17: Relations between different models of electroweak symmetry breaking [72]

3 Supersymmetry

We have seen that the Standard Model is a valid description of physical phenomena at energies lower than a few hundreds of GeV. However, there are various reasons to think that supersymmetry might appear at the TeV scale, and hence play an important role in new discoveries at the LHC, which will explore energies of the order of a TeV. In this Lecture we present and discuss supersymmetric models, with a focus on the phenomenological consequences of supersymmetry.

We first give a brief historical introduction and summarize the motivations for supersymmetry in particle physics. Subsequently we discuss the general formal structure of a physical supersymmetric theory. We then continue with some theoretical notions and applications to ‘low-energy’ particle physics around the TeV scale. Among the possible models, we focus on the Minimal Supersymmetric Standard Model (MSSM), which provides a basis for analysing supersymmetric phenomenology. Within the context of the MSSM, we discuss the principal experimental constraints on supersymmetry, and then discuss possible aspects of the detection of supersymmetry.

3.1 History and motivations

3.1.1 What is supersymmetry?

Supersymmetry is a radically new type of symmetry that transforms a bosonic state into a fermionic state, or vice versa, with $\Delta S = \pm 1/2$, where S is the spin. Denoting the supersymmetry generator by Q , we may write schematically:

$$Q|Boson\rangle = |Fermion\rangle \quad (116)$$

$$Q|Fermion\rangle = |Boson\rangle. \quad (117)$$

Formally, supersymmetry is an extension of the space-time symmetry reflected in the Poincaré group, and this was a principal motivation leading to its discovery. Initially, it was also hoped that one could use supersymmetry to combine the external space-time symmetries with internal symmetries. However, this prospect seems more distant, as discussed below.

3.1.2 Milestones

There were several attempts in the 1960s to combine internal and external symmetries, but Coleman and Mandula [73] showed in 1967 that it is impossible to combine these types of symmetry, *via* a fa-

mous no-go theorem that is discussed later in more detail. However, their proof assumed that the new symmetry should be generated by bosonic charges of integer spin. In 1971, Golfand and Likhtman [74] discovered an extension of the Poincaré group using fermionic charges of half-integer spin. In the same year, Ramond [75], Neveu and Schwarz [76] proposed supersymmetric models in two dimensions, with the aim of obtaining strings with fermionic states that could accommodate baryons. A few years later, in 1973, Volkov and Akulov [77] tried to apply a nonlinear realization of supersymmetry to neutrinos in four dimensions, but their theory did not describe correctly the low-energy interactions of neutrinos.

In the same year, Wess and Zumino [78, 79] proposed the first four-dimensional supersymmetric field theories of interest from the phenomenological point of view. Specifically, they showed how to construct supersymmetric field theories linking scalars with fermions of spin $1/2$ [78], and also fermions of spin $1/2$ with gauge particles of spin 1 [79]. Then, together with Iliopoulos and Ferrara, Zumino discovered that supersymmetry would eliminate many of the divergences present in other field theories [80, 81]. At first, these ultraviolet properties were regarded as curiosities, in particular because not all logarithmic divergences were eliminated, but attempts were made to construct phenomenological supersymmetric models, for example theories unifying matter particles and Higgs fields in the same supermultiplet. Subsequently, in 1976, two groups [82, 83] found a local version of supersymmetry in which the supersymmetry transformation depends on the space-time coordinates. This theory necessarily includes a description of gravitation, and hence has been called supergravity.

3.1.3 Why supersymmetry?

Following these formal developments, the phenomenology of supersymmetry has been studied intensively, and models based on supersymmetry are considered to be among the most serious candidates for physics beyond the SM [84–86]. Why introduce supersymmetry in particle physics? What makes it so attractive for particle physicists?

The reasons for its introduction in particle physics are principally physical, and quite diverse in nature, as we now discuss.

- The very special properties of supersymmetric field theories are helpful in addressing the naturalness of a (relatively) light Higgs boson. In the previous Lectures we have discussed the existence of enormous radiative corrections to the Higgs mass-squared, m_H^2 , which feels the virtual effects of any particle that couples directly or indirectly to the Higgs field. For example, the correction due to a fermionic loop such as that in Fig. 18(a) yields ¹⁰:

$$\Delta m_H^2 = -\frac{y_f^2}{8\pi^2} [2\Lambda^2 + 6m_f^2 \ln(\Lambda/m_f) + \dots], \quad (118)$$

where Λ is an ultraviolet cutoff used to represent the scale up to which the SM remains valid, at which new physics appears. We see that the mass of the Higgs diverges quadratically with Λ and, if we suppose that the SM remains valid up to the Planck scale, $M_P \simeq 10^{19}$ GeV, then $\Lambda = M_P$ and this correction is 10^{30} times bigger than the reasonable value of the mass-squared of the Higgs, namely $(10^2 \text{ GeV})^2$! Moreover, there is a similar correction coming from a loop of a scalar field S , such as that in Fig. 18(b):

$$\Delta m_H^2 = \frac{\lambda_S}{16\pi^2} [\Lambda^2 - 2m_S^2 \ln(\Lambda/m_S) + \dots], \quad (119)$$

where λ_S is the quartic coupling to the Higgs boson.

Comparing (118) and (119), we see that the divergent contributions terms $\propto \Lambda^2$ are cancelled if, for every fermionic loop of the theory there is also a scalar loop with $\lambda_S = 2y_f^2$. *We will see later that supersymmetry imposes exactly this relationship!* Thus supersymmetric field theories have no quadratic divergences, at both the one- and multi-loop levels, which enables a large hierarchy between different

¹⁰For this calculation, we define the Yukawa coupling of the Higgs boson to a fermion, as usual, via: $y_f H \bar{\psi} \psi$.

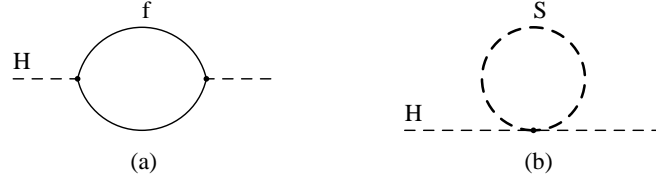

Fig. 18: One-loop quantum corrections to the mass-squared of the Higgs boson due to (a) a fermionic loop, (b) a scalar boson loop

physical mass scales to be maintained in a natural way. In addition, other logarithmic corrections to couplings also vanish in a supersymmetric theory [87].

- A second circumstantial hint in favour of supersymmetry is the fact, discussed in the previous Lecture, that precision electroweak data prefer a relatively light Higgs boson weighing less than about 150 GeV [16]. This is perfectly consistent with calculations in the minimal supersymmetric extension of the Standard Model (MSSM), in which the lightest Higgs boson weighs less than about 130 GeV [88].

- A third motivation for supersymmetry is provided by the astrophysical necessity of cold dark matter, which has a density of $\Omega_{CDM}h^2 = 0.1099 \pm 0.0062$ according to the recent measurements of WMAP [33]. This dark matter could be provided by a neutral, weakly-interacting particle weighing less than about 1 TeV, such as the lightest supersymmetric particle (LSP) χ [34]. In many supersymmetric models, a conserved quantum number called R parity guarantees that the LSP is stable. As the Universe expanded and cooled, all the particles present at high energies and densities would have annihilated, disintegrated, or combined to form baryons, atoms, etc., except for stable weakly-interacting particles such as the neutrinos and the LSP. The latter would be present in the Universe as a relic from the Big Bang, and could have the right density to constitute the majority of the cold dark matter favoured by cosmologists.

- Fourthly, let us consider the couplings that characterize each of the fundamental forces. As seen in the left panel of Fig. 19, it has been known for a long time now that if we evolve them with energy according to the renormalization-group equations of the Standard Model, we find that they never quite become equal at the same scale. However, as seen in the right panel of Fig. 19, when we include supersymmetric particles in the evolution of the couplings, they appear to intersect at exactly the same energy scale (about 2×10^{16} GeV) [89]. Nobody is forced to believe in such a ‘Grand Unification’ on the basis of this possible unification of the couplings, but it is very intriguing that supersymmetry favours unification with high precision.

- Fifthly, supersymmetry seems to be essential for the consistency of string theory [90], although this argument does not really restrict the mass scale at which supersymmetric particles should appear.

- A final hint for supersymmetry may be provided by the anomalous magnetic moment of the muon, $g_\mu - 2$, whose experimental value [91] seems to differ from that calculated in the SM, in a manner that could be explained by contributions from supersymmetric particles. The amount of this discrepancy depends on how one calculates the SM contributions to $g_\mu - 2$, in particular that due to low-energy hadronic vacuum polarization, and to a lesser extent that due to light-by-light scattering. The most direct way to calculate the hadronic vacuum polarization contribution is to use low-energy data on $e^+e^- \rightarrow$ hadrons: these do not agree perfectly, but may be combined to yield a discrepancy [92]

$$\delta a_\mu \equiv \delta \left(\frac{g_\mu - 2}{2} \right) = (24.6 \pm 8.0) \times 10^{-10}, \quad (120)$$

a discrepancy of 3.1σ , as illustrated in Fig. 20. Alternatively, and less directly, one may use τ decay data, in which case the discrepancy is reduced to about 2σ .

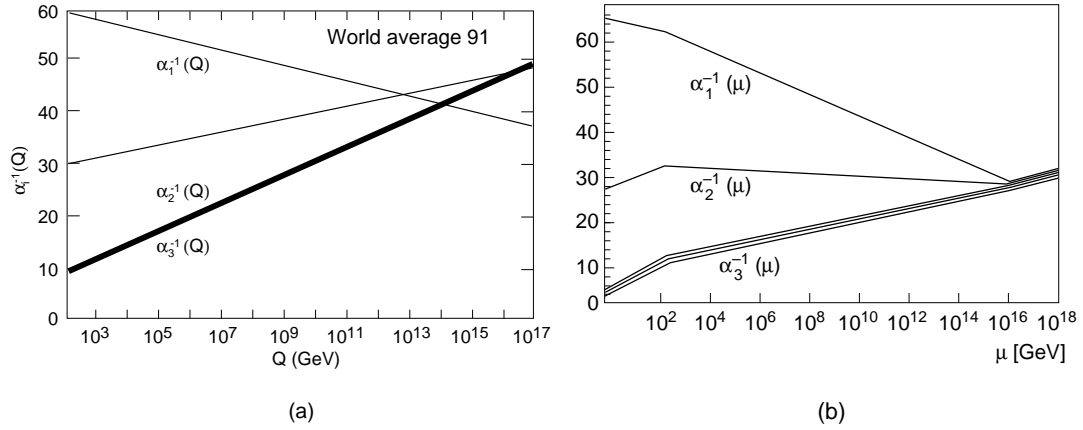

Fig. 19: The measurements of the gauge coupling strengths at LEP (a) do not evolve to a unified value if there is no supersymmetry but do (b) if supersymmetry is included [89]

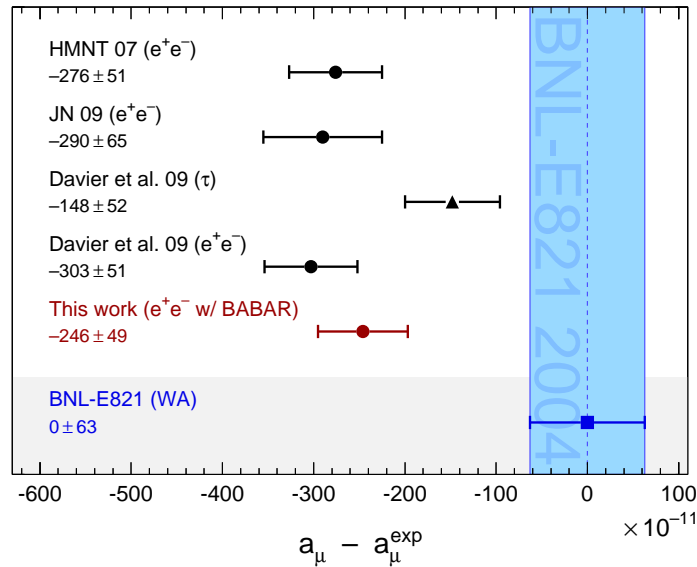

Fig. 20: SM calculations of $a_\mu \equiv (g_\mu - 2)/2$ disagree with the experimental measurement [91], particularly if they are based on low-energy e^+e^- data [73].

As we have seen, there are several arguments that motivate the study of supersymmetry¹¹. Although there are no experimental proofs of its existence, supersymmetry combines so many attractive and useful characteristics that it deserves to be studied in detail.

3.2 The structure of a supersymmetric theory

3.2.1 Interlude on ‘spinorology’

In order to lay the basis for the theoretical description of supersymmetry [84], we first present the notations and conventions that we use in the rest of the section [11, 87].

¹¹Other extensions of the SM also address some of these issues, though perhaps none do so as naturally as supersymmetry.

- We choose the *Weyl representation* for the γ matrices:

$$\gamma^\mu = \begin{pmatrix} 0 & \sigma^\mu \\ \bar{\sigma}^\mu & 0 \end{pmatrix}, \quad (121)$$

with $\sigma^\mu = (\mathbf{1}_2, \sigma^i)$, $\bar{\sigma}^\mu = (\mathbf{1}_2, -\sigma^i)$ where σ_i are the Pauli matrices, and $\gamma_5 = i\gamma^0\gamma^1\gamma^2\gamma^3 = \text{diag}(-\mathbf{1}_2, \mathbf{1}_2)$. We also use $\{\gamma^\mu, \gamma^\nu\} = 2\eta_{\mu\nu}$, where $\eta_{\mu\nu} = \text{diag}(+1, -1, -1, -1)$ is the Minkowski metric, that may be used to lower or to raise Lorentz indexes.

- A *Weyl spinor* describes a particle of spin 1/2 and given chirality. It has two components, which we label with Greek letters, $\psi_\alpha, \xi_\beta, \dots$ where $\alpha, \beta, \dots = 1, 2$. A spinor ψ_α or ψ_L will denote a particle with left chirality, whereas we denote by $\bar{\psi}^{\dot{\alpha}}$ or ψ_R a spinor with right chirality. These are related by complex conjugation:

$$(\psi_\alpha)^* = \bar{\psi}_{\dot{\alpha}} \quad , \quad (122)$$

$$(\bar{\psi}^{\dot{\alpha}})^* = \psi^\alpha \quad . \quad (123)$$

We also use the matrix $\varepsilon_{\alpha\beta} = \varepsilon_{\dot{\alpha}\dot{\beta}} \equiv i\sigma_2$ and $\varepsilon^{\alpha\beta} = \varepsilon^{\dot{\alpha}\dot{\beta}} \equiv -i\sigma_2$, which allows us to raise and lower the spinorial indices α and β .

- A *Dirac spinor* is constructed out of two Weyl spinors, and describes a particle with both chiralities. It is a spinor of four components, which we denote here using capital Greek letters: Ψ, χ, Φ, \dots . In terms of Weyl spinors, we have

$$\Psi = \begin{pmatrix} \psi_L \\ \psi_R \end{pmatrix} = \begin{pmatrix} \psi_\alpha \\ \bar{\eta}^{\dot{\alpha}} \end{pmatrix}. \quad (124)$$

The projection operators $P_{R,L} = \frac{1}{2}(1 \pm \gamma_5)$ allow us to select the right or left chirality, respectively: $\Psi_{R,L} = P_{R,L}\Psi$.

- A *charge conjugate spinor* is a spinor to which charge conjugation has been applied. It describes the antiparticle of a given particle, with opposite internal opposite charge.

$$\Psi^c = C\bar{\Psi}^T = \begin{pmatrix} \eta_\alpha \\ \bar{\psi}^{\dot{\alpha}} \end{pmatrix}, \quad (125)$$

where the charge conjugation matrix C can be written:

$$C = i\gamma^0\gamma^2. \quad (126)$$

- A *Majorana spinor* is constructed out of a single Weyl spinor, but possesses four components that are interrelated by charge conjugation, so that $\Psi_M = \Psi_M^c$:

$$\Psi_M = \begin{pmatrix} \psi_L \\ -i\sigma_2(\psi_L)^* \end{pmatrix} = \begin{pmatrix} \psi_\alpha \\ \bar{\psi}^{\dot{\alpha}} \end{pmatrix}. \quad (127)$$

3.2.2 The supersymmetry algebra and supermultiplets

As was described before, supersymmetry combines the space-time transformations of the Poincaré group with transformations of an internal symmetry. Prior to the advent of supersymmetry, there had been many previous attempts to combine internal and external symmetries, but they had always failed, for a reason demonstrated by Coleman and Mandula [73]. All the previous attempts used bosonic charges, scalar (or vector) such as the electromagnetic charge (or momentum operator):

$$\langle \text{Spin}J | Q | \text{Spin}J \rangle = q, \quad (128)$$

$$\langle \text{Spin}J | P_\mu | \text{Spin}J \rangle = p_\mu. \quad (129)$$

Conservation of momentum in any $2 \rightarrow 2$ collision implies

$$p_\mu^{(1)} + p_\mu^{(2)} = p_\mu^{(3)} + p_\mu^{(4)}. \quad (130)$$

Consider now a tensor charge $\Sigma_{\mu\nu}$: by Lorentz invariance, its diagonal matrix elements in any particle state $|a\rangle$ must be of the form

$$\langle a | \Sigma_{\mu\nu} | a \rangle = \alpha g_{\mu\nu} + \beta p_\mu p_\nu. \quad (131)$$

Conservation of the tensor charge during a $2 \rightarrow 2$ collision would require

$$p_\mu^{(1)} p_\nu^{(1)} + p_\mu^{(2)} p_\nu^{(2)} = p_\mu^{(3)} p_\nu^{(3)} + p_\mu^{(4)} p_\nu^{(4)}. \quad (132)$$

This is compatible with the linear relation (130) of conventional momentum conservation iff

$$p_\mu^{(1)} = p_\mu^{(3)} \text{ or } p_\mu^{(4)}, \quad (133)$$

implying that only exactly forward and backward scattering are allowed: no need to place any detectors at large angles! This proof can easily be extended to bosonic charges with any number of indices. However, it makes the crucial assumption that the diagonal matrix element $\langle a | Q | a \rangle \neq 0$, which is not true in supersymmetry, enabling it to evade the Coleman–Mandula no-go theorem.

Supersymmetry is generated by *spinorial* charges Q_α which have vanishing diagonal matrix elements: $\langle a | Q_\alpha | a \rangle = 0$. Being spinors, the Q_α anti-commute in the same way as other fermionic fields. It is possible to introduce more generators, but in the simplest version of supersymmetry there is just a pair of generators, Q_α and $\bar{Q}^{\dot{\alpha}}$, that are complex spinors transforming inequivalently under the Lorentz group. This is $\mathcal{N} = 1$ supersymmetry, which is essentially the only case that we consider in these notes. The initial reason for this choice is pedagogical, but in the following section we give some physical reasons for such a choice.

The algebra of the supersymmetry (like that of any other symmetry) is summarized in the commutation (and anticommutation) relations of its generators, i.e., its Lie (super)algebra. In addition to the commutation relations of the Poincaré algebra, the supersymmetry algebra includes the following relations for the generators Q_α y $\bar{Q}^{\dot{\alpha}}$:

$$[P^\mu, Q_\alpha] = 0 = [P^\mu, \bar{Q}^{\dot{\alpha}}], \quad (134)$$

$$\{Q_\alpha, \bar{Q}_{\dot{\beta}}\} = 2(\sigma_\mu)_{\alpha\dot{\beta}} P^\mu, \quad (135)$$

$$\{Q_\alpha, Q_\beta\} = \{\bar{Q}^{\dot{\alpha}}, \bar{Q}^{\dot{\beta}}\} = 0, \quad (136)$$

$$\{M_{\mu\nu}, Q_\alpha\} = \frac{1}{2}(\sigma_{\mu\nu})_{\alpha}^{\beta} Q_\beta, \quad (137)$$

$$\{M_{\mu\nu}, \bar{Q}_{\dot{\alpha}}\} = \frac{1}{2}(\bar{\sigma}_{\mu\nu})_{\dot{\alpha}}^{\dot{\beta}} \bar{Q}_{\dot{\beta}}. \quad (138)$$

What is the significance of Q_α ? First, Q is a charge in the sense of Noether's theorem, i.e, it is the charge conserved by the symmetry. As a conserved charge, it commutes with the Hamiltonian of the system and is invariant under translations, see (134). Since it possesses spin 1/2 and has two complex components, it can be written as a Weyl spinor, or alternatively as a Majorana spinor with 4 components: as such, its commutation relations with the Lorentz generators are completely determined, see (137) and (138). The non-trivial anticommutation relation above is (135): schematically $\{Q, \bar{Q}\} \sim P$, which means that Q is the 'square root' of a space-time translation.

If we want to apply supersymmetry to particle physics, we must know how to arrange particles in irreducible representations (supermultiplets), and their transformation properties. Therefore, we now study the supermultiplets and detail their contents. We recall that the Poincaré group has two Casimir

invariant elements, the spin invariant $W^2 = W^\mu W_\mu$, where $W^\mu = \frac{1}{2}\epsilon^{\mu\nu\rho\sigma} P_\nu M_{\rho\sigma}$ is the Pauli-Lubanski vector, and the mass invariant $P^2 = P^\mu P_\mu$, where P^μ is the four-momentum. In a multiplet of the Poincaré group, the particles have the same masses and the same spins. However, in the case of supersymmetry, W^2 is not an invariant of the algebra, so only mass is conserved, not spin:

$$[P^2, Q_\alpha] = 0, \quad (139)$$

$$[W^2, Q_\alpha] \neq 0. \quad (140)$$

Thus, in a supermultiplet, the particles have the same mass but different spins. We can nevertheless modify W to obtain a new invariant whose eigenvalues are of the form $2j(j+1)m^4$ with $j = 0, \frac{1}{2}, 1, \dots$ the quantum number of this ‘superspin’. This modified W is an invariant, so every irreducible representation can be characterized by a pair $[m, j]$, and the relation between the spin S and j is deduced from the relation: $M_S = M_j, M_j + \frac{1}{2}, M_j - \frac{1}{2}, M_j$. Within a given supermultiplet, there are particles of the same mass and the same superspin. In addition, an important property of any supermultiplet is that there are equal numbers of bosonic and fermionic degrees of freedom: $n_B = n_F$.

We can construct now two different supermultiplets:

▷ The fundamental representation $[m, 0]$ is called a chiral supermultiplet. The value $j = 0$ implies $M_S = 0, +\frac{1}{2}, -\frac{1}{2}, 0$, and this supermultiplet Ψ contains two real scalar fields described by a single complex scalar field (the sfermion), ϕ , and a two-component Weyl fermionic field of spin $1/2$, ψ with the same mass:

$$\Psi = (\phi, \psi_\alpha, F). \quad (141)$$

What is F ? In order that the supersymmetry be preserved in loops, where the particles are not on-shell, i.e., $P^2 \neq M^2$, it is necessary that the fermionic and bosonic degrees of freedom be balanced also *off-shell*. This is an issue because an off-shell Weyl fermion possesses 4 spin degrees of freedom, as opposed to 2 on-shell. It is necessary to add to the on-shell content of this representation another scalar complex field F that does not propagate, and does not correspond to a physical particle. This is termed an auxiliary field, and does not have a kinetic term, and the equation of motion $F = F^* = 0$ may be used to eliminate it when on-shell.

▷ The second representation we use later is the vector (or gauge) supermultiplet $[m, 1/2]$, denoted by Φ . Its field content is obtained in the same way: a Weyl fermion (or, equivalently, a Majorana fermion), called the gaugino λ_α^a , a gauge boson (of zero mass) A_μ^a , and in the presence of any chiral supermultiplet, an auxiliary real scalar field, D^a :

$$\Phi = (\lambda_\alpha^a, A_\mu^a, D^a), \quad (142)$$

where a is an index of the gauge group.

These two representations may be used to accommodate the particles of the SM and their superpartners. However, before doing so, we first construct with these two representations generic supersymmetric field theories.

3.3 Supersymmetric field theories

Before discussing supersymmetric models in general, and particularly the minimal supersymmetric extension of the SM (the MSSM), we first present, without detailed derivations, the general structure of a field theory with supersymmetry. We first introduce the model of Wess and Zumino [78] without interactions to see how the fields transform. Then we introduce the interactions, which will lead us to the new notion of the superpotential. Finally, we discuss gauge fields in a supersymmetric theory. At the end of this section, we will have accumulated enough theoretical baggage to understand the structure of the MSSM, and be able to study concretely its experimental predictions.

3.3.1 The action for free bosons and fermions is globally supersymmetric

The simplest supersymmetric action is the combination of actions for a non-interacting massless complex scalar ϕ and a spin-1/2 fermion ψ :

$$S = \int d^4x (\mathcal{L}_{scalar} + \mathcal{L}_{fermion}) : \quad (143)$$

$$\mathcal{L}_{scalar} = -\partial^\mu \phi \partial_\mu \phi^*, \quad (144)$$

$$\mathcal{L}_{fermion} = -i\psi^\dagger \bar{\sigma}^\mu \partial_\mu \psi. \quad (145)$$

If we introduce an infinitesimal supersymmetric global transformation parameter ϵ_α , which is a Weyl fermion independent of the space-time coordinates ($\partial^\mu \epsilon_\alpha = 0$), and apply it to the scalar field ϕ , the result must be proportional to the fermionic field ψ :

$$\delta\phi = \epsilon^\alpha \psi_\alpha \quad \text{and} \quad \delta\phi^* = \bar{\epsilon}_{\dot{\alpha}} \bar{\psi}^{\dot{\alpha}}, \quad (146)$$

leading to

$$\delta\mathcal{L}_{scalar} = -\epsilon^\alpha (\partial^\mu \psi_\alpha) \partial_\mu \phi^* - \partial^\mu \phi \bar{\epsilon}_{\dot{\alpha}} (\partial_\mu \bar{\psi}^{\dot{\alpha}}). \quad (147)$$

Since the mass dimensions of free boson and fermion fields are

$$[\phi] = 1, \quad [\psi] = \frac{3}{2}, \quad (148)$$

the infinitesimal fermion ϵ_α must have the dimensionality $(mass)^{-1/2}$:

$$[\epsilon] = -\frac{1}{2}, \quad (149)$$

in contrast to an usual Weyl fermion that has dimension $(mass)^{3/2}$ (148). By simple dimensional counting, the infinitesimal transformation of the fermion field must therefore be proportional to the derivative of the boson field:

$$\delta\psi_\alpha = i(\sigma^\mu \epsilon^\dagger)_\alpha \partial_\mu \phi \quad \text{and} \quad \delta\bar{\psi}^{\dot{\alpha}} = -i(\epsilon \sigma^\mu)^{\dot{\alpha}} \partial_\mu \phi^*. \quad (150)$$

Combining (146) and (150) and using the equations of motion, we see that the sum $\delta L_{scalar} + \delta L_{fermion}$ is a total divergence. This implies that the combined action, which is the space-time integral of the two free Lagrangians $L_{scalar} + L_{fermion}$, is invariant under this pair of transformations.

Does this transformation correspond to a supersymmetry transformation? To convince ourselves that this is the case, it is enough to start from a fermion ψ or from a boson ϕ , and to apply these transformations twice. We find the following chain:

$$\phi \rightarrow \psi \rightarrow \partial\phi, \quad \psi \rightarrow \partial\phi \rightarrow \partial\psi, \quad (151)$$

which means that in both cases the combined effects of two successive supersymmetry transformations are equivalent to a space-time derivative ∂^μ , and hence to the momentum operator $P^\mu \sim i\partial^\mu$. Thus we recover the result of the previous section, namely $Q^2 \sim P$, and our transformations satisfy the supersymmetric algebra. This free Lagrangian model is actually the simplest Wess–Zumino model with a single chiral supermultiplet, without mass and without interactions.

If we wish to preserve supersymmetry *off-shell*, which will be essential once we include interactions, we cannot use the equations of motion to demonstrate supersymmetry. To overcome this problem, as discussed earlier, the action S must be modified by the addition of a term that contains an auxiliary field F :

$$S = \int d^4x (\mathcal{L}_{scalar} + \mathcal{L}_{fermion} + \mathcal{L}_{aux}), \quad (152)$$

$$\mathcal{L}_{aux} = F^* F, \quad (153)$$

In the *on-shell* case, the equation of motion for F would yield $F = F^* = 0$. However, its introduction modifies the supersymmetry transformations of the fields ψ and ϕ *off-shell*. Specifically, the transformation of the field ψ is affected by the scalar field F . To see this, we first observe that the dimension of the field F is of $(mass)^2$, so that its only possible transformation law is

$$\delta F = i \bar{\epsilon}^{\dot{\alpha}} (\bar{\sigma}^{\mu})_{\dot{\alpha}}^{\beta} \partial_{\mu} \psi_{\beta} \quad \text{and} \quad \delta F^* = -i \partial_{\mu} \bar{\psi}^{\dot{\beta}} (\bar{\sigma}^{\mu})_{\dot{\beta}}^{\alpha} \epsilon_{\alpha}. \quad (154)$$

The variation of the term \mathcal{L}_{aux} in S therefore gives

$$\delta \mathcal{L}_{aux} = i \bar{\epsilon} (\bar{\sigma}^{\mu}) \partial_{\mu} \psi F^* - i \partial_{\mu} \bar{\psi} (\bar{\sigma}^{\mu}) \epsilon F. \quad (155)$$

In the *on-shell* case, as we have already seen, the equation of motion for F would yield $F = F^* = 0$, and the variation (154) would also vanish, thanks to the equation of motion for ψ . To compensate the variation (155) in the *off-shell* case, we see that we require a supplementary term in the transformation law for ψ :

$$\delta \psi_{\alpha} = i (\sigma^{\mu} \bar{\epsilon})_{\alpha} \partial_{\mu} \phi + \epsilon_{\alpha} F \quad \text{et} \quad \delta \bar{\psi}^{\dot{\alpha}} = -i (\epsilon \sigma^{\mu})^{\dot{\alpha}} \partial_{\mu} \phi^* + \bar{\epsilon}^{\dot{\alpha}} F^*. \quad (156)$$

Once again, the supplementary term vanishes when the on-shell condition $F = 0$ is applied. For simple dimensional reasons, the transformations of ϕ are not affected. It is easy to check that $\delta S = 0$ without using the equations of motion, and hence supersymmetry continues to be satisfied off-shell, thanks to the appearance of the auxiliary field F .

In fact, the auxiliary field plays an additional role. We must not forget that we have not observed supersymmetry in the range of energies explored so far. Hence, if supersymmetry exists at all in Nature, it must be broken in some way. The auxiliary field F (and the other auxiliary field D that we meet later) serve to break supersymmetry if their v.e.v.s are non-zero, as we will see in the last part of this section.

3.3.2 Interactions of the chiral multiplets

We now add to the theory interactions between the scalar and fermion fields that comprise chiral supermultiplets. The most general form of interaction that is at most quadratic in the fermion fields is

$$\mathcal{L}_{int} = -\frac{1}{2} W^{ij}(\phi, \phi^*) \psi_i \psi_j + V(\phi, \phi^*) + c.c. \quad (157)$$

We do not demonstrate it in detail, but the quantity W^{ij} must be an analytic function of the fields ϕ_i , i.e., it does not depend on the ϕ_i^* , in order to ensure that the variation due to a supersymmetry transformation of the first term of \mathcal{L}_{int} can be compensated by the variation of another term (basically because supersymmetry transforms ψ_i into ϕ_i and *vice versa*). For the same reason, W^{ij} must be completely symmetric. Hence W^{ij} must be of the form:

$$W^{ij} = \frac{\partial^2 W(\phi)}{\partial \phi_i \partial \phi_j}, \quad (158)$$

where the object W is called the *superpotential*. In order for the model to be renormalizable, the term in (157) that is bilinear in the fermion fields ψ_i can have at most a linear dependence on the scalar fields ϕ_i , implying that W can be at most cubic:

$$W = \frac{1}{2} m^{ij} \phi_i \phi_j + \frac{1}{6} y^{ijk} \phi_i \phi_j \phi_k \quad (159)$$

in the context of a renormalizable theory. Remarkably, apart from wave-function renormalization of the fields, there is no intrinsic renormalization of the superpotential parameters.

In general, the superpotential has dimension $(mass)^3$. The quadratic term in W (159) provides the (symmetric) mass matrix m^{ij} of the fermions, which is equal to the mass matrix of the scalar bosons,

by virtue of supersymmetry. The trilinear term in W provides the matrix of Yukawa couplings y^{ijk} between a scalar and two fermions, and summarizes all the interactions that are not gauge interactions. As already noted, W is an analytical function of the complex fields ϕ_i , which has an importance that we discuss later.

The requirement that \mathcal{L}_{int} be invariant under supersymmetry transformations also determines the form of the potential V . In presence of interactions, i.e., if the superpotential is non-zero, the auxiliary fields F^i introduced earlier (153) can be written in the form:

$$F_i = -\frac{\partial W(\phi)}{\partial \phi^i} = -W_i^*, \quad F^{*i} = -\frac{\partial W(\phi)}{\partial \phi_i} = -W^i. \quad (160)$$

We may therefore write the Lagrangian without introducing explicitly the F fields, in which case the potential V of the theory is:

$$V = W_i^* W^i = F_i F^{*i}. \quad (161)$$

That is automatically non-negative, since it is a sum of modulus-squared terms. If we use the general form (159) of the superpotential, we have the general Lagrangian:

$$\mathcal{L} = -\partial^\mu \phi \partial_\mu \phi^* - i\psi^\dagger \bar{\sigma}^\mu \partial_\mu \psi - \frac{1}{2} m^{ij} \psi_i \psi_j - \frac{1}{2} m_{ij}^* \psi_i^\dagger \psi_j^\dagger - V - \frac{1}{2} y^{ijk} \phi_i \psi_j \psi_k - \frac{1}{2} y_{ijk}^* \phi_i^* \psi_j^\dagger \psi_k^\dagger, \quad (162)$$

where V is given by (161), (160) and (159). It is easy to see from (159) that the boson and fermion masses are equal, as one would expect from supersymmetry.

3.3.3 Supersymmetric gauge theories

In addition to chiral fermions (quarks, leptons), the SM contains gauge fields of spin 1 (W and Z bosons, photons and gluons). In the section dedicated to the supersymmetry algebra, we saw that vector supermultiplets would provide the appropriate frameworks for such gauge fields. We now study the properties of such a supermultiplet, both with and without interactions [79]. We recall that a vector supermultiplet contains a massless gauge boson A_a^μ and a massless Weyl fermion, the gaugino λ_a , both in the adjoint representation of the gauge group. In order to go off-shell, one must introduce an auxiliary real scalar field D_a analogous to the auxiliary field F introduced for the chiral supermultiplet.

The form of the Lagrangian is completely determined by the condition of gauge invariance and of renormalizability:

$$\mathcal{L}_{gauge} = -\frac{1}{4} F_{\mu\nu}^a F^{a\mu\nu} - i\lambda^{a\dagger} \bar{\sigma}^\mu D_\mu \lambda^a + \frac{1}{2} D^a D^a, \quad (163)$$

where the gauge covariant derivative D_μ and $F_{\mu\nu}^a$ take the forms:

$$F_{\mu\nu}^a = \partial_\mu A_\nu^a - \partial_\nu A_\mu^a - gf^{abc} A_\mu^b A_\nu^c, \quad (164)$$

$$D_\mu \lambda^a = \partial_\mu \lambda^a - gf^{abc} A_\mu^b \lambda^c, \quad (165)$$

as usual for a gauge theory. Remarkably, this Lagrangian is already supersymmetric, as can be checked using the following supersymmetry transformations for the fields of the vector supermultiplet:

$$\delta A_\mu^a = \frac{1}{\sqrt{2}} \left(\epsilon^\dagger \bar{\sigma}^\mu \lambda^a + \lambda^{a\dagger} \bar{\sigma}^\mu \epsilon \right), \quad (166)$$

$$\delta \lambda_\alpha^a = -\frac{i}{2\sqrt{2}} (\sigma^\mu \bar{\sigma}^\nu \epsilon)_\alpha F_{\mu\nu}^a + \frac{1}{\sqrt{2}} \epsilon_\alpha D^a, \quad (167)$$

$$\delta D^a = \frac{i}{\sqrt{2}} \left(\epsilon^\dagger \bar{\sigma}^\mu D_\mu \lambda^a - D_\mu \lambda^{a\dagger} \bar{\sigma}^\mu \epsilon \right). \quad (168)$$

In the absence of any interactions with chiral supermultiplets, the equation of motion for the auxiliary field D^a is simply $D^a = 0$, as seen directly from the Lagrangian (163), since it does not have a kinetic term and therefore does not propagate.

However, in the SM the gauge fields do interact with the chiral fermions. Hence, in our supersymmetric version we have to consider interactions between chiral supermultiplets and vector supermultiplets. As in the SM, the usual derivatives ∂^μ of the fermions must be replaced by gauge-covariant derivatives D^μ , and the same applies to their scalar supersymmetric partners. The supersymmetric transformation laws of the chiral supermultiplets must be changed to take into account the variations of these new terms. As a result, the equation of motion for D^a becomes:

$$D^a = -g(\phi^* T^a \phi), \quad (169)$$

where the T^a are the generators of the gauge group and g is its coupling constant, and the full scalar potential is

$$V = F_i F^{*i} + \frac{1}{2} \sum_a D^a D^a = W_i^* W^i + \frac{1}{2} \sum_a g^2 (\phi^* T^a \phi)^2. \quad (170)$$

This potential is completely determined by the Yukawa couplings (*via* the F term) and by the gauge interactions (*via* the D term). The full scalar potential is automatically non-negative, which is important for the spontaneous breaking of the symmetry.

In a globally supersymmetric theory, spontaneous breaking may occur *via* a v.e.v. for the D term or the F term, either of which would give a positive contribution to the vacuum energy. However, it is difficult to construct models that are interesting for phenomenology, and most model-builders pursue the spontaneous breaking of local supersymmetry in the context of a supergravity theory, in which this positive contribution may be cancelled.

3.4 Low-energy supersymmetric models

In this section we apply the results obtained in the previous section, with the objective of supersymmetrizing the Standard Model while preserving its successful characteristics. The minimal supersymmetric extension of the SM is called the MSSM [85, 86]. We will present its particle content (including the nomenclature of the new particles), we will discuss how the electroweak symmetry may be broken, and we will outline an effective framework for describing the breaking of supersymmetry. Later we will present typical predictions of the MSSM. Along the way, we will also mention possible variants of the MSSM, because Nature might very well have chosen a path more complex than this minimal model.

3.4.1 How many supersymmetries?

As well as mentioned already, the number of supersymmetric generators Q_α may be $\mathcal{N} \geq 1$. Supersymmetric theories with $\mathcal{N} \geq 2$ have some characteristic advantages, e.g., they have fewer divergences, which make them very interesting theoretically. Specifically, in the $\mathcal{N} = 2$ case there is only a finite number of divergent Feynman diagrams, and in the $\mathcal{N} = 4$ case there are none, i.e., any theory with $\mathcal{N} = 4$ supersymmetries is intrinsically finite, and it is easy to construct finite $\mathcal{N} = 2$.

Unfortunately, it is not possible to construct realistic models with $\mathcal{N} \geq 2$, because they do not allow the violation of parity that is observed in the weak interactions. This is because a supermultiplet of a theory with $\mathcal{N} \geq 2$ supersymmetries necessarily incorporates both left- and right-handed fermions in the same supermultiplet: applying a supersymmetry charge Q changes the helicity by $1/2$, so applying two charges relates states with helicity $\pm 1/2$, implying that they are in the same representation of the gauge group, and hence have the same interactions. This contradicts experimental observations, which tell us, for example, that the left-handed electron (which forms part of a doublet in the SM) does not have the same interaction with W bosons as the right-handed electron (which is a singlet with zero electroweak isospin that does not feel the $SU(2)$ weak interaction). Models with $\mathcal{N} \geq 2$ cannot describe the physics of the SM particles observed at low energy.

3.4.2 The particle content in the MSSM

The supermultiplets in the minimal $\mathcal{N} = 1$ case are

- the chiral supermultiplet that includes a fermion of spin 1/2 and a boson of spin 0,
- the vector supermultiplet that includes a boson of spin 1 and one fermion of spin 1/2.

Could we link the particles of the SM in such multiplets, i.e., could we associate quarks and leptons with the bosons W , Z , the photon, and so on? The answer is no, because this would raise problems for the conservation of their quantum numbers. Specifically, the gauge bosons and the fermions do not have the same transformation properties under the SM gauge group, since they possess different quantum numbers, e.g., quarks are triplets of the colour group whereas gauge bosons are either octets (the gluons) or singlets (the other gauge bosons), and leptons carry lepton numbers whereas gauge bosons do not. Simple $\mathcal{N} = 1$ supersymmetry does not modify these quantum numbers, so we cannot associate any gauge boson with a known fermion or *vice versa*. Therefore, we have to postulate unseen supersymmetric partners for all the known particles. Table 3 lists, for every SM particle, the name, spin and notation for its spartner.

Table 3: Particle content of the MSSM

Particle	Spartner	Spin
quarks q	squarks \tilde{q}	0
→ top t	stop \tilde{t}	
→ bottom b	sbottom \tilde{b}	
...		
leptons l	sleptons \tilde{l}	0
→ electron e	selectron \tilde{e}	
→ muon μ	smuon $\tilde{\mu}$	
→ tau τ	stau $\tilde{\tau}$	
→ neutrinos ν_ℓ	sneutrinos $\tilde{\nu}_\ell$	
gauge bosons	gauginos	1/2
→ photon γ	photino $\tilde{\gamma}$	
→ boson Z	Zino \tilde{Z}	
→ boson B	Bino \tilde{B}	
→ boson W	Wino \tilde{W}	
→ gluon g	gluino \tilde{g}	
Higgs bosons $H_i^{\pm,0}$	higgsinos $\tilde{H}_i^{\pm,0}$	1/2

Before going on to the following sections, we make a few observations. First, we note that the spartners of SM fermions and gauge bosons are of lower spin. *A priori*, one could have considered associating the fermions of the SM with spartners of spin 1, and the gauge bosons with spartners of spin 3/2. However, to introduce a particle of spin 1 would require introducing a new gauge interaction, and hence a non-minimal model. Also, introducing particles of spin > 1 would make the theory non-renormalizable, i.e., it would no longer be possible to absorb the divergences in perturbation theory in a finite number of physical quantities¹².

Secondly, we recall that in the SM the right-handed fermions have different interactions from the left-handed fermions, e.g., being singlets of $SU(2)$ instead of doublets. In supersymmetry, the left- and right-handed must belong to different supermultiplets, and have distinct spartners, e.g., $q_L \rightarrow \tilde{q}_L$ and

¹²Supergravity does allow a restricted number $\mathcal{N} \leq 8$ of spin-3/2 gravitino partners of the spin-2 graviton to be introduced, but they do not carry conventional gauge interactions.

$q_R \rightarrow \tilde{q}_R$. These two squarks are quite different, and we use the chirality index L or R to identify them, even though the concept of handedness does not make physical sense for a scalar particle, whose only helicity is $\lambda = 0$. In general, the \tilde{f}_L and \tilde{f}_R mix, and the physical mass eigenstates are combinations of them. In constructing the Yukawa interactions of the MSSM, it is often convenient to work with superfields that comprise conjugates of the \tilde{f}_R and their scalar partners: these are left-handed chiral supermultiplets denoted by F^c .

Thirdly, we note that, besides the new partners, at least two doublets of Higgs bosons are required. To understand why, we recall that, in the study of supersymmetric theories, we introduced the notion of the superpotential. This governs all the possible Yukawa interactions of the matter particles with the Higgs fields. In the SM, if we use a Higgs field h to give masses to the quarks of type ‘down’, *via* Yukawa couplings $q\bar{d}h$, we could use the complex conjugate field h^* to give masses to quarks of type ‘up’, *via* couplings $q\bar{u}h^*$. However, we recall that in a supersymmetric theory the superpotential is an analytic function of the superfields that cannot depend on their complex conjugates. Therefore, we must use separate Higgs supermultiplets (denoted by capital letters) with opposite hypercharge quantum numbers, and interactions of the forms QD^cH_d and QU^cH_u . Charged leptons may acquire masses through interactions of the form LE^cH_d . We also note that pairs of Higgs superfields are needed in order to cancel the triangle anomalies that would be generated by higgsino fermion loops.

Fourthly, we note that in general the $\tilde{\gamma}, \tilde{Z}, \tilde{W}$ and \tilde{H} mix, and the experimentally observable mass eigenstates are combinations of these gauginos and higgsinos that are generally named neutralinos $\tilde{N}_{1,2,3,4}^0$, which have zero electrical charge, and charginos $\tilde{C}_{1,2}^\pm$ ¹³, which are electrically charged and mix the \tilde{W}^\pm and the \tilde{H}^\pm .

3.4.3 Interactions in the MSSM

The MSSM is the minimal supersymmetric extension of the Standard Model [85,86]. The quarks and the leptons are put together in chiral superfields with their superpartners that have the same charges under $SU(3)_C$, $SU(2)_L$ y $U(1)_Y$. The gauge bosons are placed with their fermionic superpartners in vector superfields. The superpotential of the MSSM is

$$\mathcal{W} = \mathcal{Y}_u QU^c H_u + \mathcal{Y}_d QD^c H_d + \mathcal{Y}_e LE^c H_d + \mu H_u H_d, \quad (171)$$

where we recall that the Q and L are the superfields containing the left-handed quarks and leptons, respectively, and the U^c, D^c and E^c are the superfields containing the left-handed antiquarks and antileptons, which are the charge conjugates of the right-handed quarks and leptons. Note that, for clarity, we have suppressed the $SU(2)$ indexes. The \mathcal{Y} are 3×3 Yukawa matrices in flavour space, and do not have dimensions. After electroweak symmetry breaking, they give the masses to the quarks and leptons as well as the CKM angles and phases. As already mentioned, two Higgs doublets, H_u y H_d , are needed because of the analytical form of the superpotential.

The $\mu H_u H_d$ term is permitted by the symmetries of the MSSM and is required in order to have a suitable vacuum after electroweak symmetry breaking. The quantity μ has the dimension of a mass, and phenomenology requires it to be of the order of a TeV. The origin of μ is a puzzle: it might be associated to the scale of supersymmetry breaking.

The superpotential (171) determines all the non-gauge interactions of the MSSM, thanks to the formula (157), and the form of the effective potential of the theory is given by formula (170).

The next-to-minimal supersymmetric extension of the Standard Model (NMSSM) [93] is the simplest extension of the MSSM. In this model, the particle content is modified by the addition of a new singlet chiral supermultiplet S , with some additional superpotential terms:

$$\mathcal{W}_{NMSSM} = \frac{1}{6}kS^3 + \frac{1}{2}\mu_S S^2 + \lambda S H_u H_d + \mathcal{W}_{MSSM}. \quad (172)$$

¹³These are often denoted by $\tilde{\chi}_{1,2,3,4}^0$ and $\tilde{\chi}_{1,2}^\pm$, respectively.

The principal interest of the NMSSM is to propose a solution to the μ problem. Specifically, if the scalar part of S has a non-zero vacuum expectation value $\langle S \rangle$, the last term in (172) gives an effective μ term: $\mu_{eff} = \lambda \langle S \rangle$. Assuming that a soft supersymmetry-breaking scalar mass for S also appears in \mathcal{L}_{soft} , its v.e.v. is naturally of the order of $m_{soft} \sim \mathcal{O}(1)$ TeV, the typical mass scale of the other scalars and gauginos. Thus the effective value of μ is of the order of 1 TeV, rather than being a parameter whose magnitude is independent of the scale of supersymmetry breaking.

Phenomenologically the NMSSM differs from the MSSM because it allows the lightest Higgs boson to become heavier. In addition, the fermionic partner of S can mix with the four neutralinos of the MSSM. Thus the experimental signatures of the NMSSM may differ significantly from those of the MSSM.

3.4.4 Soft supersymmetry breaking

We have discussed so far the supersymmetric aspects of the MSSM. However, we know that supersymmetry must be broken: the selectron weighs more than the electron, squarks weigh more than quarks, etc. Therefore, we must introduce into the model the breaking of supersymmetry. However, the mechanism and the effective scale of its breaking are still unknown. Hence we adopt the *ad hoc* strategy of parametrizing the breaking of supersymmetry in terms of effective soft¹⁴ low-energy supersymmetry-breaking terms that are added to the Lagrangian [94]. For a general supersymmetric theory, the form of these soft supersymmetry-breaking terms \mathcal{L}_{soft} in the Lagrangian is

$$\mathcal{L} \supset \mathcal{L}_{soft} = -\frac{1}{2}(M_\lambda \lambda^a \lambda^a + c.c) - m_{ij}^2 \phi_j^* \phi_i + \left(\frac{1}{2} b_{ij} \phi_i \phi_j + \frac{1}{6} a_{ijk} \phi_i \phi_j \phi_k + c.c \right). \quad (173)$$

This breaks supersymmetry explicitly, since only the the gauginos λ^a and the scalars ϕ_i have mass terms, and the trilinear terms with coefficients a_{ijk} are also not of supersymmetric form. In the case of the MSSM, \mathcal{L}_{soft} takes the following general form in terms of the spartner fields of the MSSM:

$$\begin{aligned} -\mathcal{L}_{soft} &= \frac{1}{2}(M_3 \tilde{g} \tilde{g} + M_2 \tilde{W} \tilde{W} + M_1 \tilde{B} \tilde{B} + c.c) \\ &+ \tilde{Q}^\dagger m_Q^2 \tilde{Q} + \tilde{U}^\dagger m_{\tilde{U}}^2 \tilde{U} + \tilde{D}^\dagger m_D^2 \tilde{D} + \tilde{L}^\dagger m_L^2 \tilde{L} + \tilde{E}^\dagger m_E^2 \tilde{E} \\ &+ (\tilde{U}^\dagger a_U \tilde{Q} H_u - \tilde{D}^\dagger a_D \tilde{Q} H_d - \tilde{E}^\dagger a_E \tilde{L} H_d + c.c) \\ &+ m_{H_u}^2 H_u^* H_u + m_{H_d}^2 H_d^* H_d + (b H_u H_d + c.c). \end{aligned} \quad (174)$$

The masses M_3 , M_2 and M_1 of the gauginos are complex in general, which introduces 6 parameters. The quantities m_Q , m_L and $m_{\tilde{u}}$, are the mass matrices of the squarks and sleptons, which are hermitian 3×3 matrices in family space, adding 45 more unknown parameters. The couplings a_U , a_D , ..., are also complex 3×3 matrices, characterized by 54 parameters. In addition, the quadratic couplings of the Higgs bosons introduce 4 more parameters, so that the whole \mathcal{L}_{soft} contains a total of 109 unknown parameters, including many that violate CP!

Supersymmetry itself is a very powerful principle whose implementation introduces only one new parameter (μ) in the MSSM. However, in our present state of ignorance, the breaking of supersymmetry introduces many new parameters. On the other hand, the number of soft parameters can be reduced by postulating symmetries or making supplementary hypotheses. Measuring the parameters of soft supersymmetry breaking would allow us to go beyond the phenomenological parametrization (174), and open the way to testing models of the high-energy dynamics that breaks supersymmetry.

¹⁴Here, the adjective ‘soft’ means that they do not introduce quadratic divergences.

3.4.5 Electroweak symmetry breaking and supersymmetric Higgs bosons

As we have already seen, the Higgs sector of the MSSM contains two complex doublets:

$$H_u = \begin{pmatrix} H_u^0 \\ H_u^- \end{pmatrix}, \quad H_d = \begin{pmatrix} H_d^+ \\ H_d^0 \end{pmatrix}. \quad (175)$$

Electroweak symmetry breaking is a little bit more complicated than its analogue in the Standard Model. At tree level, we can write the effective scalar potential (after simplifications whose details we do not reproduce):

$$\begin{aligned} V = & (|\mu|^2 + m_{H_u}^2)|H_u^0|^2 + (|\mu|^2 + m_{H_d}^2)|H_d^0|^2 - b(H_u^0 H_d^0 + c.c) \\ & + \frac{1}{8}(g_2^2 + g_1^2)(|H_u^0|^2 - |H_d^0|^2)^2. \end{aligned} \quad (176)$$

The terms proportional to $|\mu|^2$ originate from the F terms in the supersymmetric effective potential, and the terms proportional to the gauge couplings (g_1, g_2) originate from the D terms. The other terms originate from \mathcal{L}_{soft} (without mentioning the other scalars that do not play any role here). Spontaneous electroweak symmetry breaking can arise with this form of potential if the b parameter satisfies:

$$b^2 > (|\mu|^2 + m_{H_u}^2)(|\mu|^2 + m_{H_d}^2), \quad (177)$$

In addition, we want the potential to be bounded from below. Thus

$$2b < 2|\mu|^2 + m_{H_u}^2 + m_{H_d}^2 \quad (178)$$

at tree level¹⁵. After electroweak symmetry breaking, both the fields H_u^0 and H_d^0 must develop v.e.v.'s, in order to give masses to all the quarks and leptons:

$$\langle H_u^0 \rangle = v_u, \quad \langle H_d^0 \rangle = v_d. \quad (179)$$

Comparing with the Standard Model, we have

$$v^2 = v_u^2 + v_d^2 = \frac{2m_Z^2}{(g_2^2 + g_1^2)}. \quad (180)$$

Conventionally, one defines also the $\tan \beta$ parameter:

$$\tan \beta = \frac{v_u}{v_d} : 0 < \beta < \frac{\pi}{2}. \quad (181)$$

At the minimum of the potential

$$\frac{\partial V}{\partial H_u^0} = \frac{\partial V}{\partial H_d^0} = 0, \quad (182)$$

giving the two relations

$$\begin{aligned} |\mu|^2 + m_{H_u}^2 &= b \tan \beta - \frac{m_Z}{2} \cos^2 \beta, \\ |\mu|^2 + m_{H_d}^2 &= b \cot \beta + \frac{m_Z}{2} \cos^2 \beta. \end{aligned} \quad (183)$$

These expressions are important because they relate a measurable quantity, m_Z , to the soft parameters. We note that some amount of fine-tuning would be required if the soft parameters were much larger than m_Z . We note also that the vacuum conditions (183) do not depend on the phase of μ .

¹⁵As we shall see shortly, radiative corrections to the effective potential play important roles.

The two complex Higgs doublets of the MSSM have a total of 8 degrees of freedom. However, the Higgs mechanism for electroweak breaking uses 3 degrees of freedom to give longitudinal polarization states, and hence masses, to the two W bosons and to the Z boson. Therefore, five physical Higgs bosons remain in the spectrum. Of these, two are neutral Higgs bosons that are even under the CP transformation, called h^0 and H^0 . In addition, there is one neutral Higgs boson that is odd under CP, called A^0 . The final two Higgs bosons are charged, the H^\pm .

At tree level, the masses of the supersymmetric Higgs bosons are:

$$m_{h^0, H^0}^2 = \frac{1}{2} \left(m_{A^0}^2 + m_Z^2 \mp \sqrt{(m_{A^0}^2 + m_Z^2)^2 - 4m_{A^0}^2 m_Z^2 \cos^2 2\beta} \right), \quad (184)$$

$$m_{A^0}^2 = \frac{2b}{\sin 2\beta}, \quad (185)$$

$$m_{H^\pm}^2 = m_{A^0}^2 + m_W^2, \quad (186)$$

and the mass of the h^0 is bounded from above by:

$$m_{h^0} < |\cos 2\beta| m_Z. \quad (187)$$

This upper limit on m_{h^0} may be traced to the fact that the quartic Higgs coupling λ is fixed in the MSSM, being equal to the square of the electroweak gauge coupling (up to numerical factors). This means that λ and hence m_{h^0} cannot be very large.

However, the above relations are valid only at tree level, and the masses of Higgs scalars have one-loop radiative corrections that are not negligible [88]. The most important corrections for m_h are those due to the top quark and squark:

$$\Delta m_h^2 = \frac{3m_t^4}{4\pi^2 v^2} \ln \left(\frac{m_{\tilde{t}_1} m_{\tilde{t}_2}}{m_t^2} \right) + \frac{3m_t^4}{8\pi^2 v^2} f(m_{\tilde{t}_1}^2, m_{\tilde{t}_2}^2, \mu, \tan \beta), \quad (188)$$

where $m_{\tilde{t}_{1,2}}$ are the physical masses of the stops (that are mixtures of \tilde{t}_R and \tilde{t}_L), and $f(m_{\tilde{t}_1}^2, m_{\tilde{t}_2}^2, \mu, \tan \beta)$ is a non-logarithmic function that can be found in [10]. The correction Δm_h^2 depends quartically on the mass of the top, making it more important than the one-loop corrections due to other quarks, leptons, and gauge multiplets. After including this correction, the mass of the lightest Higgs boson may be as large as

$$m_h \lesssim 130 \text{ GeV}, \quad (189)$$

for masses of sparticles about a TeV. This is seen in Fig. 21, which shows m_h as a function of m_{A^0} for different values of $\tan \beta$. As noted, the range (189) for the mass of the lightest supersymmetric Higgs boson is in perfect agreement with the indications provided by the electroweak data, as discussed in Lecture 1! This is just one of many attractive features of supersymmetry that we review here.

3.4.6 R parity and dark matter

We introduced above the superpotential (174) of the MSSM, which includes only the Yukawa interactions of the SM. However, gauge invariance, Lorentz invariance, and analyticity in the SM fields would allow us to introduce in the superpotential other terms that do not have any correspondence with the SM, and do not preserve either baryon number and/or lepton number¹⁶. These terms are

$$\mathcal{W}_{RPV} = \lambda_{ijk} L_i L_j E_k + \lambda'_{ijk} L_i Q_j D_k^c + \lambda''_{ijk} U_i^c D_j^c D_k^c + \mu'_i L_i H_u, \quad (190)$$

¹⁶The conservation of B and L in the SM is an accidental symmetry of its renormalizable interactions that is *a priori* not obligatory. As we see later in the context of Grand Unified Theories, the SM, non-renormalizable terms that violate L or B may be added to the SM Lagrangian. In the MSSM, such L - and B -violating may appear at the renormalizable level.

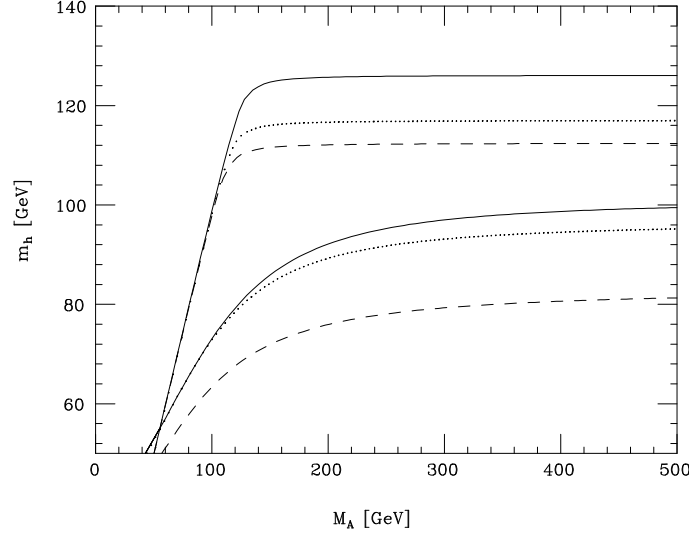

Fig. 21: The mass of the lightest supersymmetric Higgs boson as a function of m_{A^0} for different values of $\tan\beta$

where λ, λ' and λ'' are arbitrary dimensionless coupling constants, and the μ'_i are parameters with the dimension of a mass.

These parameters are subject to strong phenomenological restrictions. For example, a combination of the second and third terms would induce rapid disintegration of the proton *via* squark exchange, whereas the proton is very stable, with a lifetime exceeding $\sim 10^{33}$ years. This implies that the product of such terms must be strongly suppressed [95]:

$$|\lambda'\lambda''| < \mathcal{O}(10^{-9}). \quad (191)$$

One way to avoid all such terms is to add to the MSSM a new symmetry called R -parity, given by the following combination baryon number, lepton number, and spin S :

$$R = (-1)^{3(B-L)+2S}. \quad (192)$$

This is a multiplicatively-conserved quantum number in the SM, since all the SM particles and Higgs bosons have even R parity: $R = +1$. On the other hand, all the sparticles have odd R parity ($R = -1$).

Conservation of R parity would have important phenomenological consequences:

- The sparticles are produced in even numbers (usually two at time), for example: $\bar{p}p \rightarrow \tilde{q}\tilde{g}X$, $e^+e^- \rightarrow \tilde{\mu}^+\tilde{\mu}^-$.
- Each sparticle decays into another sparticle (or into an odd number of them), for example: $\tilde{q} \rightarrow q\tilde{g}$, $\tilde{\mu} \rightarrow \mu\tilde{\gamma}$.
- The lightest sparticle (LSP) must be stable, since it has $R = -1$. If it is electrically neutral, it can interact only weakly with ordinary matter, and may be a good candidate for the non-baryonic dark matter that is required by cosmology [34].

The dark matter particles should have neither electric charge nor strong interactions, otherwise they would be visible or detectable, e.g., through their binding to ordinary matter to form what would look like anomalous heavy nuclei, which have never been seen. We therefore expect any dark matter particle to have only weak interactions, in which case, if it was produced at a collider such as the LHC, it would carry energy–momentum away invisibly. Accordingly, most LHC searches for supersymmetry focus on events with missing transverse momentum, though searches for signatures of R -violating models are also considered.

The existence of a stable, weakly-interacting LSP is a very important prediction of the MSSM, but its nature and its total contribution to the density of dark matter depend on the parameters of the MSSM. One weakly-interacting candidate was the lightest sneutrino, but this has already been excluded by direct searches at LEP and by experiments searching directly for dark matter. The remaining candidate particles are the lightest neutralino χ of spin 1/2, and the gravitino of spin 3/2. As we discuss later, there are chances to detect a neutralino LSP at the LHC in events with missing energy, or directly as astrophysical dark matter. On the other hand, the interactions of the gravitino are so weak that it could not be detected as astrophysical dark matter, and could only be detected indirectly in collider experiments.

3.5 Phenomenology of supersymmetry

As we have seen, the soft supersymmetry-breaking sector of the MSSM has over a hundred parameters. This renders very difficult the interpretation of experimental constraints and (hopefully) the extraction of the experimental values of these parameters. A simplifying hypothesis is to assume *universality* at a certain scale before renormalization, leading us to the constrained MSSM (CMSSM):

- The gaugino masses are assumed to be equal at some input GUT or supergravity scale: $M_3 = M_2 = M_1 = m_{1/2}$;
- The scalar masses of squarks and sleptons are assumed to be universal at the same scale: $m_Q^2 = m_{Uc}^2 = \dots = m_0^2$, as are the soft supersymmetry-breaking contributions to the Higgs masses $m_{H_u}^2 = m_{H_d}^2 = m_0^2$;
- The trilinear couplings are related by a universal coefficient A_0 to the corresponding Yukawa couplings: $a_u = A_0 y_u$, $a_d = A_0 y_d$, $a_e = A_0 y_e$.

Simplifying the MSSM to the CMSSM reduces the number of parameters from over one hundred to only 4: $m_{1/2}$, m_0 , A_0 , $\tan \beta$ and the sign of μ [the magnitude of μ is fixed by the electroweak vacuum conditions: see (183)]. The CMSSM hypothesis is very practical from a phenomenological point of view, though questionable from a purely theoretical point of view. The CMSSM and the simplification of \mathcal{L}_{soft} are inspired by simple supergravity models where the breaking of supersymmetry is mediated by gravity, though minimal supergravity models actually impose two additional constraints. On the other hand, generic string models often lead to different patterns of soft supersymmetry breaking.

Dropping universality for squarks or sleptons with the same quantum numbers but in different generations would lead to problems with flavour-changing neutral interactions, and Grand Unified Theories relate the soft supersymmetry-breaking masses of squarks and sleptons with different quantum numbers. However, there is no strong theoretical or phenomenological reason to postulate universality for the soft supersymmetry-breaking contributions to the Higgs masses. One may relax this assumption for the Higgs scalar masses-squared m_H^2 by assuming the same single-parameter non-universal Higgs mass parameter (the NUHM1), or by allowing the non-universal Higgs mass parameters to be different (the NUHM2).

3.6 Renormalization of the soft supersymmetry-breaking parameters

In our ignorance of the underlying mechanism of supersymmetry breaking, it is usually assumed that this occurs at some large mass scale far above a TeV, perhaps around the grand unification or Planck scale. The soft supersymmetry-breaking parameters therefore undergo significant renormalization between this input scale and the electroweak scale. Although quadratic divergences are absent from a softly-broken supersymmetric theory, it still has logarithmic divergences that may be treated using the renormalization group (RG).

At leading order in the RG, which resums the leading one-loop logarithms, the renormalizations of the soft gaugino masses M_a are the same as for the corresponding gauge couplings:

$$Q \frac{dM_a}{dQ} = \beta_a M_a, \quad (193)$$

where β_a is the standard one-loop renormalization coefficient including supersymmetric particles that is discussed in more detail in the next Lecture. As a result of (193), to leading order

$$M_a(Q) = \frac{\alpha_a(Q)}{\alpha_{GUT}} m_{1/2} \quad (194)$$

if the gauge couplings α_a and the gaugino masses are assumed to unify at the same large mass scale M_{GUT} . As a consequence of (194), one expects the gluino to be heavier than the wino: $m_{\tilde{g}}/m_{\tilde{W}} = \alpha_3/\alpha_2$ at leading order.

The soft supersymmetry-breaking scalar masses-squared m_0^2 acquire renormalizations related to the gaugino masses *via* the gauge couplings, and to the scalar masses and trilinear parameters A_λ *via* the Yukawa couplings:

$$\frac{Q dm_0^2}{dQ} = \frac{1}{16\pi^2} [-g_a^2 M_a^2 + \lambda^2(m_0^2 + A_\lambda^2)]. \quad (195)$$

The latter effect is significant for the stop squark, one of the Higgs multiplets, and possibly the other third-generation sfermions if $\tan \beta$ is large. For the other sfermions, at leading order one has

$$m_0^2(Q) = m_0^2 + C m_{1/2}^2, \quad (196)$$

where the coefficient C depends on the gauge quantum numbers of the corresponding sfermion. Consequently, one expects the squarks to be heavier than the sleptons. Specifically, in the CMSSM one finds at the electroweak scale that

$$\text{squarks : } m_q^2 \sim m_0^2 + 6m_{1/2}^2, \quad (197)$$

$$\text{left-handed sleptons: } m_{\tilde{\ell}_L}^2 \sim m_0^2 + 0.5m_{1/2}^2, \quad (198)$$

$$\text{right-handed sleptons: } m_{\tilde{\ell}_R}^2 \sim m_0^2 + 0.15m_{1/2}^2. \quad (199)$$

The difference between the left and right slepton masses may have implications for cosmology, as we discuss later. A small difference is also expected between the masses of the left and right squarks, but this is relatively less significant numerically.

The CKM mixing between quarks is related in the SM to off-diagonal entries in the Yukawa coupling matrix, and shows up in leading-order charged-current interactions and flavour-changing neutral current (FCNC) interactions induced at the loop level. One would expect additional FCNCs to be induced by similar loop diagrams involving squarks, which would propagate through the RGEs (195) and induce flavour-violating terms in the sfermion mass matrices. However, experiment imposes important upper limits on such additional supersymmetric flavour effects. As already discussed, these would be suppressed (though non-zero) if the soft supersymmetry-breaking scalar masses of all sfermions with the same quantum numbers were the same before renormalization. The hypothesis of Minimal Flavour Violation (MFV) is that flavour mixing of squarks and sleptons is induced only by the CKM mixing in the quark sector and the corresponding MNS mixing in the lepton sector: see the next Lecture. The MFV hypothesis requires also that the soft supersymmetry-breaking trilinear parameters A be universal for sfermions with the same quantum numbers: $A_\lambda = A_0 \lambda$. However, the MFV hypothesis does permit the appearance of 6 additional phases beyond those in the CKM model for quarks: 3 phases for the different gaugino mass parameters, and 3 phases for the different A_0 coefficients [96].

Results of typical numerical calculations of these renormalization effects in the CMSSM are shown in Fig. 22. An important effect illustrated there is that the RGEs may drive $m_{H_u}^2$ negative at some low renormalization scale Q_N , thanks to the top quark Yukawa coupling appearing in (195)¹⁷. A negative value of $m_{H_u}^2$ would trigger electroweak symmetry breaking at a scale $\sim Q_N$. Since the negative value of

¹⁷The effect of the Yukawa coupling is to *increase* m_0^2 as Q increases, i.e., to *decrease* m_0^2 as Q decreases.

$m_{H_u}^2$ is due to the logarithmic renormalization by the top quark Yukawa coupling, electroweak symmetry breaking appears at a scale exponentially smaller than the input GUT or Planck scale:

$$\frac{m_W}{M_{GUT,P}} = \exp\left(-\frac{\mathcal{O}(1)}{\alpha_t}\right) : \alpha_t \equiv \frac{\lambda_t^2}{4\pi}. \quad (200)$$

In this way, it is possible for the electroweak scale to be generated naturally at a scale ~ 100 GeV if the top quark is heavy: $m_t \sim 60$ to 100 GeV, a realization that long predated the discovery of just such a heavy top quark.

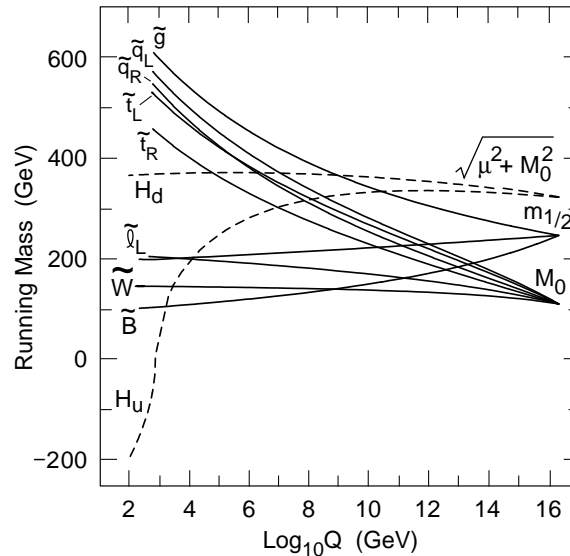

Fig. 22: Calculations of the renormalization of soft supersymmetry-breaking particle masses, assuming universal scalar and gaugino masses $m_0, m_{1/2}$ at the GUT scale. Note that strongly-interacting particles have larger physical masses at low scales, and the $m_{H_u}^2$ is driven negative, triggering electroweak symmetry breaking.

3.6.1 Particle masses and mixing

There are aspects of sparticle masses and mixing that are important for phenomenology, as we now discuss.

Sfermions: As we have seen, each flavour of charged lepton or quark has both left- and right-handed components $f_{L,R}$, and these have separate spin-0 boson superpartners $\tilde{f}_{L,R}$. These have different isospins $I = \frac{1}{2}, 0$, but may mix as soon as the electroweak gauge symmetry is broken. Thus, for each flavour we should consider a 2×2 mixing matrix for the $\tilde{f}_{L,R}$, which takes the following general form:

$$M_f^2 \equiv \begin{pmatrix} m_{\tilde{f}_{LL}}^2 & m_{\tilde{f}_{LR}}^2 \\ m_{\tilde{f}_{LR}}^2 & m_{\tilde{f}_{RR}}^2 \end{pmatrix}. \quad (201)$$

The diagonal terms may be written in the form

$$m_{\tilde{f}_{LL,RR}}^2 = m_{\tilde{f}_{L,R}}^2 + m_{\tilde{f}_{L,R}}^{D^2} + m_f^2, \quad (202)$$

where m_f is the mass of the corresponding fermion, $\tilde{m}_{\tilde{f}_{L,R}}^2$ is the soft supersymmetry-breaking mass discussed in the previous section, and $m_{\tilde{f}_{L,R}}^{D^2}$ is a contribution due to the quartic D terms in the effective

potential:

$$m_{\tilde{f}_{L,R}}^{D^2} = m_Z^2 \cos 2\beta (I_3 + \sin^2 \theta_W Q_{em}), \quad (203)$$

where the term $\propto I_3$ is non-zero only for the \tilde{f}_L . Finally, the off-diagonal mixing term takes the general form

$$m_{\tilde{f}_{L,R}}^2 = m_f \left(A_f + \mu \frac{\tan \beta}{\cot \beta} \right) \text{ for } f = \begin{matrix} e, \mu, \tau, d, s, b \\ u, c, t \end{matrix}. \quad (204)$$

It is clear that $\tilde{f}_{L,R}$ mixing is likely to be important for the \tilde{t} , and it may also be important for the $\tilde{b}_{L,R}$ and $\tilde{\tau}_{L,R}$ if $\tan \beta$ is large.

We also see from (202) that the diagonal entries for the $\tilde{t}_{L,R}$ would be different from those of the $\tilde{u}_{L,R}$ and $\tilde{c}_{L,R}$, even if their soft supersymmetry-breaking masses were universal, because of the m_f^2 contribution. In fact, we also expect non-universal renormalization of $m_{\tilde{t}_{LL,RR}}^2$ (and also $m_{\tilde{b}_{LL,RR}}^2$ and $m_{\tilde{\tau}_{LL,RR}}^2$ if $\tan \beta$ is large), because of Yukawa effects analogous to those discussed previously for the renormalization of the soft Higgs masses. For these reasons, the $\tilde{t}_{L,R}$ are not usually assumed to be degenerate with the other squark flavours.

Charginos: These are the supersymmetric partners of the W^\pm and H^\pm , which mix through a 2×2 matrix

$$-\frac{1}{2} (\tilde{W}^-, \tilde{H}^-) M_C \begin{pmatrix} \tilde{W}^+ \\ \tilde{H}^+ \end{pmatrix} + \text{herm.conj.} \quad (205)$$

where

$$M_C \equiv \begin{pmatrix} M_2 & \sqrt{2} m_W \sin \beta \\ \sqrt{2} m_W \cos \beta & \mu \end{pmatrix}. \quad (206)$$

Here M_2 is the unmixed $SU(2)$ gaugino mass and μ is the Higgs mixing parameter introduced previously.

Neutralinos: These are characterized by a 4×4 mass mixing matrix [34], which takes the following form in the $(\tilde{W}^3, \tilde{B}, \tilde{H}_2^0, \tilde{H}_1^0)$ basis :

$$m_N = \begin{pmatrix} M_2 & 0 & \frac{-g_2 v_2}{\sqrt{2}} & \frac{g_2 v_1}{\sqrt{2}} \\ 0 & M_1 & \frac{g' v_2}{\sqrt{2}} & \frac{-g' v_1}{\sqrt{2}} \\ \frac{-g_2 v_2}{\sqrt{2}} & \frac{g' v_2}{\sqrt{2}} & 0 & \mu \\ \frac{g_2 v_1}{\sqrt{2}} & \frac{-g' v_1}{\sqrt{2}} & \mu & 0 \end{pmatrix} \quad (207)$$

Note that this has a structure similar to M_C (206), but with its entries replaced by 2×2 submatrices. As has already been mentioned, one often assumes that the $SU(2)$ and $U(1)$ gaugino masses $M_{1,2}$ are universal at the GUT or supergravity scale, so that

$$M_1 \simeq M_2 \frac{\alpha_1}{\alpha_2}, \quad (208)$$

so the relevant parameters of (207) are generally taken to be $M_2 = (\alpha_2/\alpha_{GUT})m_{1/2}$, μ and $\tan \beta$.

In the limit $M_2 \rightarrow 0$, the lightest neutralino χ would be approximately a photino, and it would be approximately a higgsino in the limit $\mu \rightarrow 0$. However, these idealized limits are excluded by unsuccessful LEP and other searches for neutralinos and charginos. Possibilities that persist are that χ be approximately a Bino, \tilde{B} , or that it has a substantial higgsino component.

3.7 Constraints on the MSSM

Most of the current constraints on possible physics beyond the SM are negative and, specifically, no sparticle has ever been detected. The concordance with the SM predictions means that, in general, one can only set lower limits on the possible masses of supersymmetric particles. However, there are two observational indications of physics beyond the SM that may, in the supersymmetric context, be used for setting *upper* limits of the masses of the supersymmetric particles. As discussed earlier, these two hints for new physics are the anomalous magnetic moment of the muon, $g_\mu - 2$, which seems to disagree with the prediction of the SM (at least if this is calculated using low-energy e^+e^- data as an input), and the density of cold dark matter Ω_{CDM} . However, these discrepancies may be explained either with supersymmetry or with other possible extensions of the SM, so their interpretations require special care. Nevertheless, these may be regarded as additional phenomenological motivations for supersymmetry, in addition to the more theoretical motivations described in the beginning of this section, such as the naturalness of the hierarchy of mass scales in physics, grand unification, string theory, etc. Therefore, in addition to considering the more direct searches for supersymmetry, it is also natural to ask what $g_\mu - 2$ and Ω_{CDM} may imply for the parameters of supersymmetric models. Figure 23 compiles the impacts of various constraints on supersymmetry, assuming that the soft supersymmetry-breaking contributions $m_{1/2}, m_0$ to the different scalars and gauginos are each universal at the GUT scale (the scenario called the CMSSM), and that the lightest particle is the lightest neutralino χ .

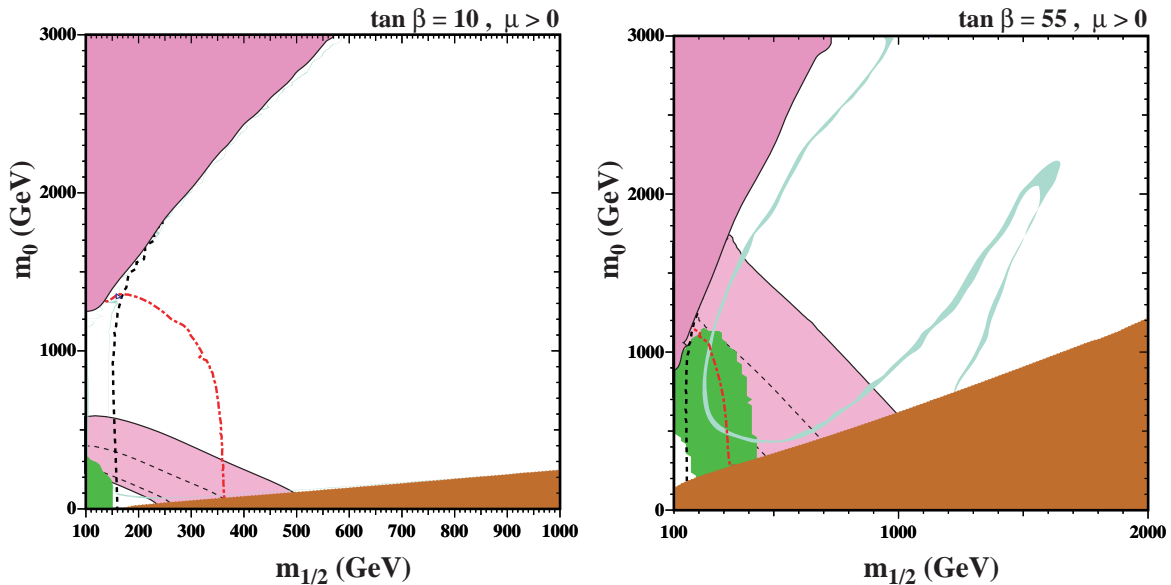

Fig. 23: The CMSSM $(m_{1/2}, m_0)$ planes for (a) $\tan \beta = 10$ and (b) $\tan \beta = 55$, assuming $\mu > 0$, $A_0 = 0$, $m_t = 173.1$ GeV and $m_b(m_b)_{\overline{MS}}^{SM} = 4.25$ GeV. The near-vertical (red) dot-dashed lines are the contours for $m_h = 114$ GeV, and the near-vertical (black) dashed line is the contour $m_{\chi^\pm} = 104$ GeV. Also shown by the dot-dashed curve in the lower left is the region excluded by the LEP bound $m_{\tilde{e}} > 99$ GeV. The medium (dark green) shaded region is excluded by $b \rightarrow s\gamma$, and the light (turquoise) shaded area is the cosmologically preferred region. In the dark (brick red) shaded region, the LSP is the charged $\tilde{\tau}_1$. The region allowed by the measurement of $g_\mu - 2$ at the $2\text{-}\sigma$ level, assuming the e^+e^- calculation of the Standard Model contribution, is shaded (pink) and bounded by solid black lines, with dashed lines indicating the $1\text{-}\sigma$ ranges (updated from [98]).

Experiments at LEP and the Tevatron collider, in particular, have made direct searches for supersymmetry using the missing-energy-momentum signature. LEP established lower limits ~ 100 GeV on the masses of many charged sparticles without strong interactions, such as sleptons and charginos. The Tevatron collider has established the best lower limits on the masses of squarks and gluinos, ~ 400 GeV. In view of the greater renormalization of the squark and gluino masses than for charginos and sleptons,

see (194) and (199), these two sets of limits are quite complementary.

Another important constraint is provided by the LEP lower limit on the Higgs mass: $m_H > 114.4$ GeV [20]. This holds in the Standard Model, for the lightest Higgs boson h in the general MSSM for $\tan\beta \lesssim 8$, and almost always in the CMSSM for all $\tan\beta$, at least as long as CP is conserved¹⁸. Since m_h is sensitive to sparticle masses, particularly $m_{\tilde{t}}$ via the loop corrections (188), the Higgs limit also imposes important constraints on the soft supersymmetry-breaking CMSSM parameters, principally $m_{1/2}$ [98], as seen in Fig. 23.

Important constraints are imposed on the CMSSM parameter space by flavour physics, specifically the agreement with data of the SM prediction for the decay $b \rightarrow s\gamma$, as well as the upper limit on the decay $B_s \rightarrow \mu^+\mu^-$, which is important at large $\tan\beta$ in particular.

We see in Fig. 23 that narrow strips of the $(m_{1/2}, m_0)$ planes are compatible [98] with the range of the astrophysical cold dark matter density favoured by WMAP and other experiments. However, these strips vary with $\tan\beta$ and A_0 . In fact, foliation by these WMAP strips covers large fractions of the $(m_{1/2}, m_0)$ plane as $\tan\beta$ and A_0 are varied. Away from these narrow strips, the relic neutralino density exceeds the WMAP range over most of the $(m_{1/2}, m_0)$ planes shown in Fig. 23. In its left panel, the relic density is reduced into the WMAP range only in the shaded strip at $m_0 \sim 100$ GeV that extends to $m_{1/2} \sim 900$ GeV. This reduction is brought about by co-annihilations between the LSP χ (which is mainly a Bino) and sleptons that are only slightly heavier, most notably the lighter stau and the right selectron and smuon, which are significantly lighter than the left sleptons, as discussed earlier. In the right panel of Fig. 23 for $\tan\beta = 50$, this co-annihilation strip moves to larger m_0 . Also, it is extended to larger $m_{1/2}$, as a result of a reduction in the relic density due to rapid $\chi - \chi$ annihilations through direct-channel heavy Higgs (H, A) states. In addition to these visible WMAP regions, there is in principle another allowed strip at very large values of m_0 , called the focus-point region, where the LSP becomes relatively light and acquires a substantial higgsino component, favouring annihilation via W^+W^- final states.

Finally, also shown in the two panels of Fig. 23 are the regions favoured by the supersymmetric interpretation of the discrepancy (120) between the experimental measurement of $g_\mu - 2$ and the value calculated in the SM using low-energy e^+e^- data [98]. The favoured regions are displayed as bands corresponding to $\pm 2\sigma$. We see that they can be used to set *upper* limits on the sparticle masses! In particular, $g_\mu - 2$ disfavors the focus-point region, where m_0 is so large that the supersymmetric contribution to $g_\mu - 2$ is negligible, and also the region at large $\tan\beta$ and large $m_{1/2}$ where the neutralinos may annihilate rapidly through direct-channel heavy-Higgs states.

3.8 Frequentist analysis of the supersymmetric parameter space

In a recent paper [99] the likely range of parameters of the CMSSM and NUHM1 has been estimated using a frequentist approach, by building a χ^2 likelihood function with contributions from the various relevant observables, including precision electroweak physics, $g_\mu - 2$, the lower limit on the lightest Higgs boson mass (taking into account the theoretical uncertainty in the FeynHiggs calculation of M_h [100]), the experimental measurement of $\text{BR}(b \rightarrow s\gamma)$ (which agrees with the SM), the experimental upper limit on $\text{BR}(B_s \rightarrow \mu^+\mu^-)$, and Ω_{CDM} . This frequentist analysis used a Markov chain Monte Carlo technique to sample thoroughly the $(m_0, m_{1/2})$ plane up to masses of several TeV, including the focus-point and rapid-annihilation regions, for a wide range of values of A_0 and $\tan\beta$.

We display in Fig. 24 the $\Delta\chi^2$ functions in the $(m_0, m_{1/2})$ planes for the CMSSM (left plot) and for the NUHM1 (right plot). The parameters of the best-fit CMSSM point are $m_0 = 60$ GeV, $m_{1/2} = 310$ GeV, $A_0 = 130$ GeV, $\tan\beta = 11$, and $\mu = 400$ GeV (corresponding nominally to $M_h = 114.2$ GeV and an overall $\chi^2 = 20.6$ for 19 d.o.f. with a probability of 36%), which are very

¹⁸The lower bound on the lightest MSSM Higgs boson may be relaxed significantly if CP violation feeds into the MSSM Higgs sector [97].

close to the ones previously reported in Ref. [101]. The corresponding parameters of the best-fit NUHM1 point are $m_0 = 150$ GeV, $m_{1/2} = 270$ GeV, $A_0 = -1300$ GeV, $\tan\beta = 11$, and $m_{h_1}^2 = m_{h_2}^2 = -1.2 \times 10^6$ GeV² or, equivalently, $\mu = 1140$ GeV, yielding $\chi^2 = 18.4$ (corresponding to a similar fit probability to the CMSSM) and $M_h = 120.7$ GeV. The similarities between the best-fit values of m_0 , $m_{1/2}$ and $\tan\beta$ in the CMSSM and the NUHM1 suggest that the model frameworks used are reasonably stable: if they had been very different, one might well have wondered what would be the effect of introducing additional parameters, as in the NUHM2 with two non-universality parameters in the Higgs sector.

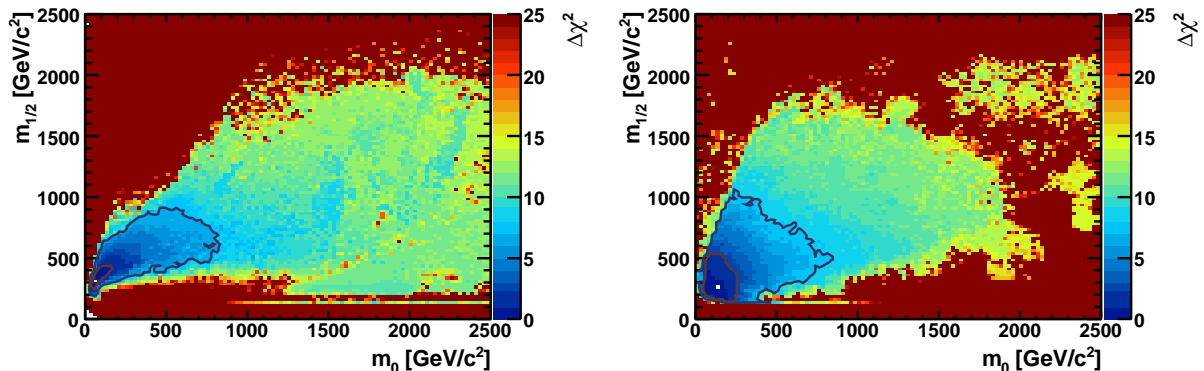

Fig. 24: The $\Delta\chi^2$ functions in the $(m_0, m_{1/2})$ planes for the CMSSM (left plot) and for the NUHM1 (right plot), as found in frequentist analyses of the parameter spaces. We see that the co-annihilation regions at low m_0 and $m_{1/2}$ are favoured in both cases [101].

These best-fit points are both in the co-annihilation region of the $(m_0, m_{1/2})$ plane, as can be seen in Fig. 24. The C.L. contours extend to slightly larger values of m_0 in the CMSSM, while they extend to slightly larger values of $m_{1/2}$ in the NUHM1, as was already shown in Ref. [101] for the 68% and 95% C.L. contours. However, the qualitative features of the $\Delta\chi^2$ contours are quite similar in the two models, indicating that the preference for small m_0 and $m_{1/2}$ are quite stable and do not depend on details of the Higgs sector. We recall that it was found in Ref. [101] that the focus-point region was disfavoured at beyond the 95% C.L. in both the CMSSM and the NUHM1. We see in Fig. 24 that this region is disfavoured at the level $\Delta\chi^2 \sim 8$ in the CMSSM and > 9 in the NUHM1.

The favoured values of the particle masses in both models are such that there are good prospects for detecting supersymmetric particles in CMS [28] and ATLAS [29] even in the early phase of the LHC running with reduced centre-of-mass energy and limited luminosity, as seen in Fig. 25. The best-fit points and most of the 68% confidence level regions are within the region of the $(m_0, m_{1/2})$ plane that could be explored with 100/pb of data at 14 TeV in the centre of mass, and hence perhaps with 200/fb of data at 10 TeV¹⁹. Almost all the 95% confidence level regions would be accessible to the LHC with 1/fb of data at 14 TeV. As seen in Fig. 25, in substantial parts of these regions there are good prospects for detecting $\tilde{q} \rightarrow q\ell^+\ell^-\chi$ decays, which are potentially useful for measuring sparticle mass parameters, and the lightest supersymmetric Higgs boson may also be detectable in \tilde{q} decays.

The best-fit spectra in the CMSSM and NUHM1 are shown in Fig. 26: they are relatively similar, though the heavier Higgs bosons, the gluinos, and the squarks may be somewhat heavier in the CMSSM, whereas the heavier charginos and neutralinos may be heavier in the NUHM1 [101]. There are considerable uncertainties in these spectra, as seen in Fig. 27 [99]. However, in general there are strong

¹⁹The comparisons are made with experimental simulations for $\tan\beta = 10$ and $A_0 = 0$, whereas the frequentist analysis sampled all values of $\tan\beta$ and A_0 . As it happens, the preferred values of $\tan\beta$ in both the CMSSM and the NUHM1 are quite close to 10: the value of A_0 is relatively unimportant for the experimental analysis.

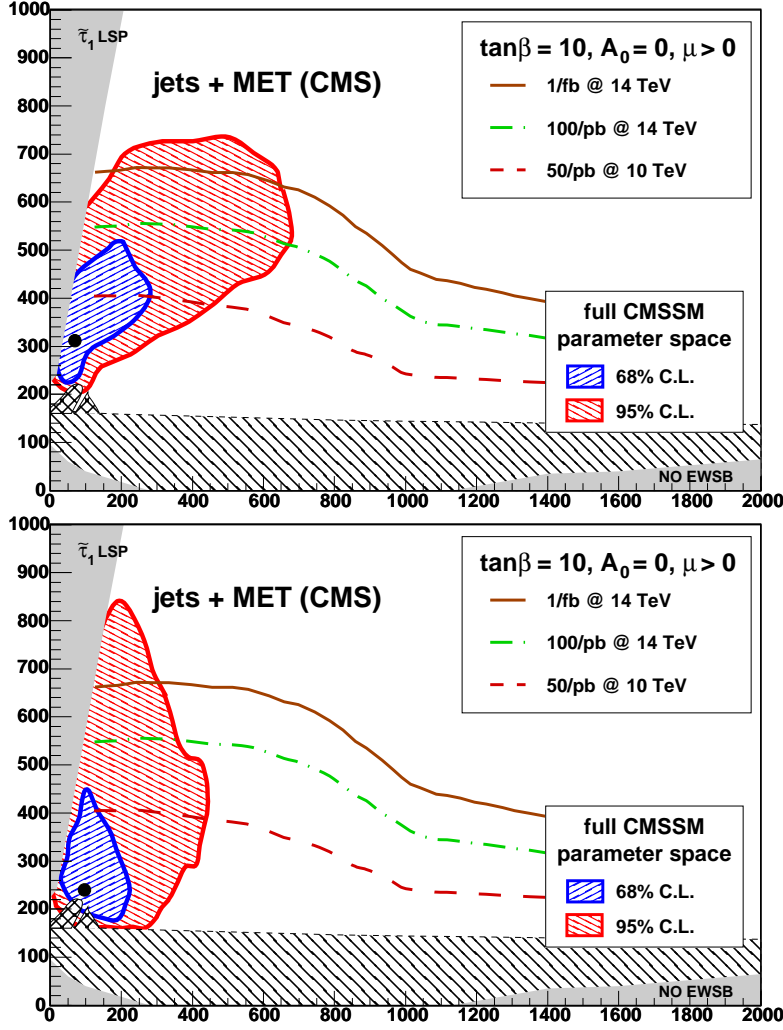

Fig. 25: The $(m_0, m_{1/2})$ planes in the CMSSM (upper) and the NUHM1 (lower) for $\tan\beta = 10$ and $A_0 = 0$. The dark shaded areas at low m_0 and high $m_{1/2}$ are excluded due to a scalar tau LSP, the light shaded areas at low $m_{1/2}$ do not exhibit electroweak symmetry breaking. The nearly horizontal line at $m_{1/2} \approx 160$ GeV in the lower panel has $m_{\tilde{\chi}_1^\pm} = 103$ GeV, and the area below is excluded by LEP searches. Just above this contour at low m_0 in the lower panel is the region that is excluded by trilepton searches at the Tevatron. Shown in each plot is the best-fit point [101], indicated by a star, and the 68 (95)% C.L. contours from the fit as dark grey/blue (light grey/red) overlays, scanned over all $\tan\beta$ and A_0 values. The plots also show some 5σ discovery contours for CMS [28] with 1 fb^{-1} at 14 TeV, 100 pb^{-1} at 14 TeV and 50 pb^{-1} at 10 TeV centre-of-mass energy [101].

correlations between the different sparticle masses, as exemplified in Fig. 28, though the correlation is weaker, e.g., for the lighter stau and the LSP in the NUHM1²⁰.

Finally, a result from this frequentist analysis that also concerns LHC physics, but away from the high-energy frontier. We see in Fig. 29 that the branching ratio for $B_s \rightarrow \mu^+ \mu^-$ may well exceed considerably its value in the SM, particularly at large $\tan\beta$. This is true to some extent in the CMSSM, and even more so in the NUHM1. Particularly in the latter case, this decay might perhaps be accessible to the LHCb experiment during initial LHC running. Therefore, there may be important competition for ATLAS and CMS in their quest to discover supersymmetry!

²⁰This reflects the possible appearance of rapid direct-channel annihilations also at low $m_{1/2}$ and low $\tan\beta$, allowing an escape from the co-annihilation region where $m_\chi \sim m_{\tilde{\tau}_1}$.

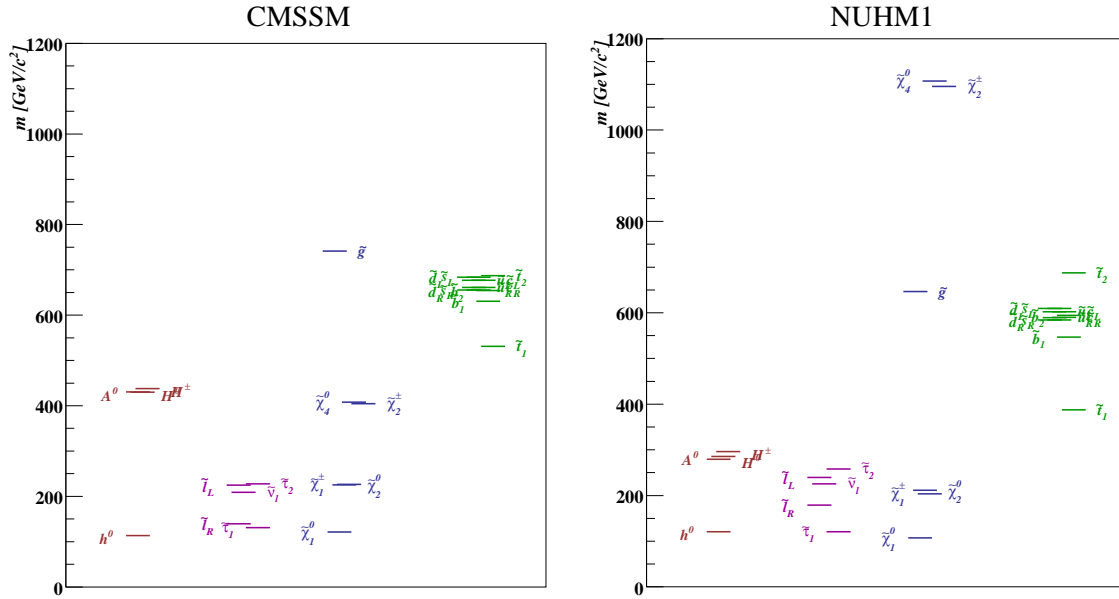

Fig. 26: The spectra at the best-fit points: left — in the CMSSM with $m_{1/2} = 311$ GeV, $m_0 = 63$ GeV, $A_0 = 243$ GeV, $\tan\beta = 11.0$, and right — in the NUHM1 with $m_{1/2} = 265$ GeV, $m_0 = 143$ GeV, $A_0 = -1235$ GeV, $\tan\beta = 10.4$, and $\mu = 1110$ GeV [101].

4 Further beyond: GUTs, string theory and extra dimensions

4.1 Grand unification

Gauge theories, particularly non-Abelian Yang–Mills theories, are the only suitable framework for describing interactions in particle physics. In the SM, there are three different gauge groups $SU(3)_C$, $SU(2)_L$, and $U(1)_Y$, and correspondingly there are three different couplings. It is logical to look for a single, more powerful non-Abelian grand unified gauge group with a single coupling g_{GUT} that would enable us to unify the three couplings, and might provide interesting relations between the other different SM parameters such as Yukawa couplings and hence fermion masses²¹. As a first approximation, we assume that the effects of the gravitational interaction are negligible, which is generally true if the grand unification scale M_{GUT} is significantly smaller than the Planck mass. As we see later, it turns out that typical estimations, based on extrapolation to very high energies of the known physics of the SM [102], give a grand unification scale of the order of 10^{16} GeV, which is about a thousand times smaller than the Planck scale $M_{Pl} = \mathcal{O}(10^{19})$ GeV.

Postulating a single group to describe all the interactions of particle physics also implies new relations between the matter particles themselves, as well as new gauge bosons. Specifically, if the symmetry changes then the representations, and hence the organization of the particles into multiplets, also change. There are some hints for this in low-energy physics, such as charge quantization and the correlation of fractional electrical charges with colour charges, and the cancellation of anomalies between the leptons and the quarks that also lead us to anticipate an organization simpler than the SM.

Clearly, one must recover the Standard Model at low energy, implying that in these Grand Unified Theories (GUTs) one must also study the breaking of the GUT group $G \rightarrow SU(3)_C \otimes SU(2)_L \otimes U(1)_Y$.

This section begins with a presentation of the renormalization-group evolution equations of the three SM gauge couplings and studies their possible unification at some GUT scale. Subsequently, some specific examples of GUTs are discussed, notably the prototype based on the group $SU(5)$, which makes

²¹In this section, we denote the couplings by g_1 for the $U(1)$ subgroup, g_2 for $SU(2)$, and g_3 for $SU(3)$, which have the appropriate normalizations for grand unification [see later].

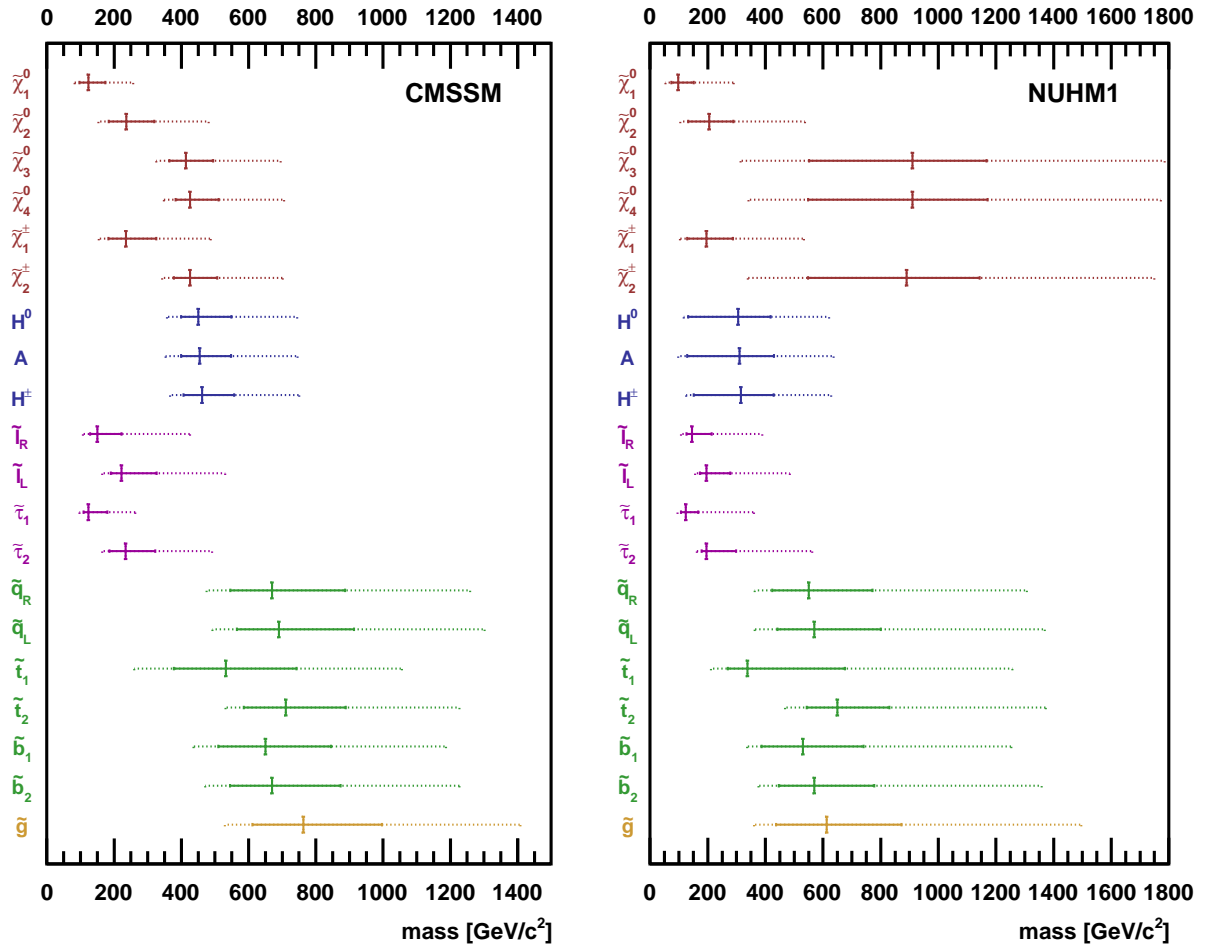

Fig. 27: Spectra in the CMSSM (left) and the NUHM1 (right). The vertical solid lines indicate the best-fit values, the horizontal solid lines are the 68% C.L. ranges, and the horizontal dashed lines are the 95% C.L. ranges for the indicated mass parameters [99].

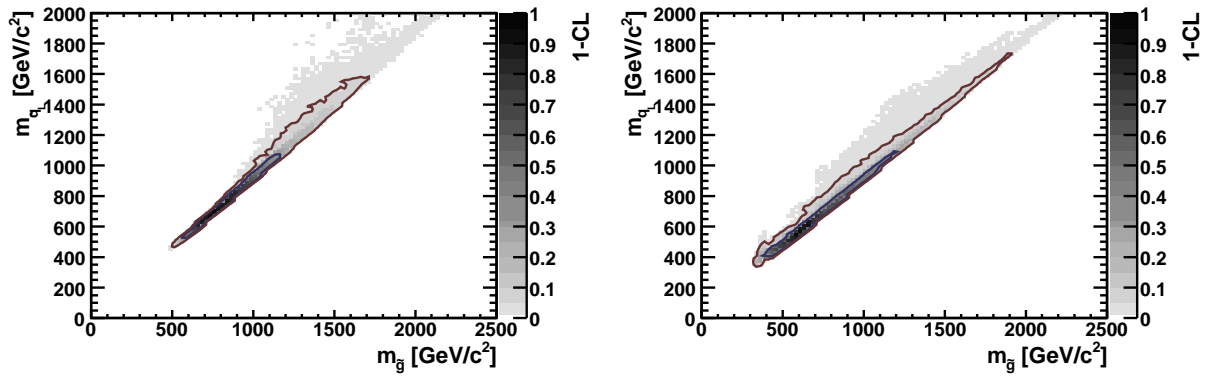

Fig. 28: The correlations between the gluino mass, $m_{\tilde{g}}$, and the masses of the the left-handed partners of the five light squark flavours, $m_{\tilde{q}_L}$, are shown in the CMSSM (left panel) and in the NUHM1 (right panel) [99].

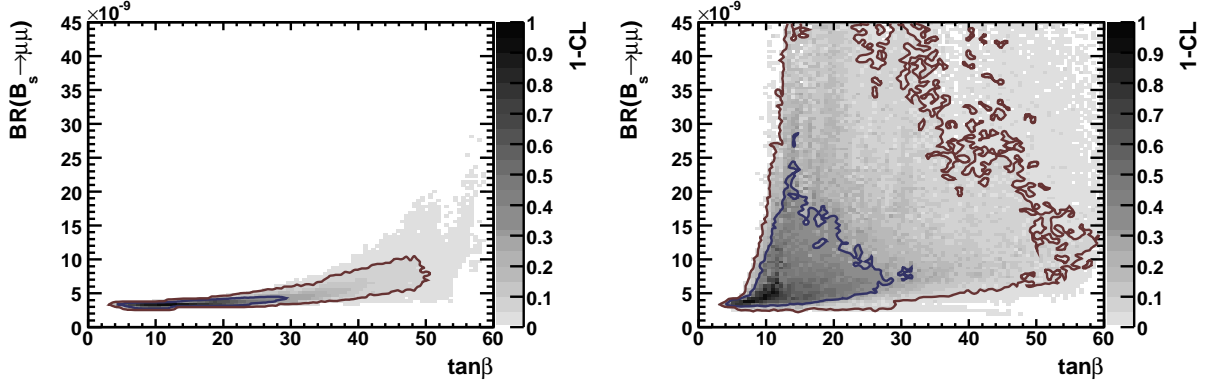

Fig. 29: The correlation between the branching ratio for $B_s \rightarrow \mu^+ \mu^-$ and $\tan \beta$ in the CMSSM (left panel) and in the NUHM1 (right panel) [99].

possible a simple discussion of many properties of GUTs. This is followed by a short discussion of typical predictions of these models, such as the decay of the proton and the relations between the masses of the quarks and leptons. We finish by discussing some of the advantages, problems, and perspectives of GUT models.

4.1.1 The evolution equations for gauge couplings

The first apparent obstacle to the philosophy of grand unification is the fact that the strong coupling strength $\alpha_3 = g_3^2/4\pi$ is much stronger than the electroweak couplings at present-day energies: $\alpha_3 \gg \alpha_2, \alpha_1$. However, the strong coupling is asymptotically free [9]:

$$\alpha_3(Q) \simeq \frac{12\pi}{(33 - 2N_q) \ln(Q^2/\Lambda_3^2)} + \dots, \quad (209)$$

where N_q is the number of quarks, $\Lambda_3 \simeq$ few hundred MeV is an intrinsic scale of the strong interactions, and the dots in (209) represent higher-loop corrections to the leading one-loop behaviour shown. The other SM gauge couplings also exhibit logarithmic violations analogous to (209). For example, the fine-structure constant $\alpha_{em} = 1/137.035999084(51)$ is renormalized to effective value of $\alpha_{em}(m_Z) \sim 1/128$ at the Z mass scale. The renormalization-group evolution for the $SU(2)$ gauge coupling corresponding to (209) is

$$\alpha_2(Q) \simeq \frac{12\pi}{(22 - 2N_q - N_{H/2}) \ln(Q^2/\Lambda_2^2)} + \dots, \quad (210)$$

where we have assumed equal numbers of quarks and leptons, and N_H is the number of Higgs doublets. Taking the inverses of (209) and (210), and then taking their difference, we find

$$\frac{1}{\alpha_3(Q)} - \frac{1}{\alpha_2(Q)} = \left(\frac{11 + N_{H/2}}{12\pi} \right) \ln \left(\frac{Q^2}{m_X^2} \right) + \dots \quad (211)$$

Note that we have absorbed the scales Λ_3 and Λ_2 into a single grand unification scale M_X where $\alpha_3 = \alpha_2$.

Evaluating (211) when $Q = \mathcal{O}(M_W)$, where $\alpha_3 \gg \alpha_2 = 0(\alpha_{em})$, we derive the characteristic feature [102]

$$\frac{m_{GUT}}{m_W} = \exp \left(\mathcal{O} \left(\frac{1}{\alpha_{em}} \right) \right), \quad (212)$$

i.e., the grand unification scale is exponentially large. As we see in more detail later, in most GUTs there are new interactions mediated by bosons weighing $\mathcal{O}(m_X)$ that cause protons to decay with a lifetime αm_X^4 . In order for the proton lifetime to exceed the experimental limit, we need $m_X \gtrsim 10^{14}$ GeV and hence $\alpha_{em} \lesssim 1/120$ in (212) [103]. On the other hand, if the neglect of gravity is to be consistent, we need $m_X \lesssim 10^{19}$ GeV and hence $\alpha_{em} \gtrsim 1/170$ in (212) [103]. The fact that the measured value of the fine-structure constant α_{em} lies in this allowed range may be another hint favouring the GUT philosophy.

Further empirical evidence for grand unification is provided by the prediction it makes for the neutral electroweak mixing angle [102]. Calculating the renormalization of the electroweak couplings, one finds

$$\sin^2 \theta_W = \frac{\alpha_{em}(m_W)}{\alpha_2(m_W)} \simeq \frac{3}{8} \left[1 - \frac{\alpha_{em}}{4\pi} \frac{110}{9} \ln \frac{m_X^2}{m_W^2} \right], \quad (213)$$

which can be evaluated to yield $\sin^2 \theta_W \sim 0.210$ to 0.220 , if there are only SM particles with masses $\lesssim m_X$ [102]. This is to be compared with the experimental value $\sin^2 \theta_W = 0.23120 \pm 0.00015$ in the $\overline{\text{MS}}$ renormalization scheme. Considering that $\sin^2 \theta_W$ could *a priori* have had any value between 0 and 1, this is an impressive qualitative success. The small discrepancy can be removed by adding some extra particles, such as the supersymmetric particles in the MSSM.

To see this explicitly, we may write

$$\sin^2 \theta(m_Z) = \frac{g'^2}{g_2^2 + g'^2} = \frac{3}{5} \frac{g_1^2(m_Z)}{g_2^2(m_Z) + \frac{3}{5}g_1^2(m_Z)}, \quad (214)$$

where g_1 is defined in such a way that its quadratic Casimir coefficient, summed over all the particles in a single generation, is the same as for g_2 and g_3 , which is the appropriate normalization within a GUT. Using the one-loop RGEs, we can then write

$$\sin^2 \theta(m_Z) = \frac{1}{1 + 8x} \left[3x + \frac{\alpha_{em}(m_Z)}{\alpha_3(m_Z)} \right] = \frac{1}{5} \left(\frac{b_2 - b_3}{b_1 - b_2} \right), \quad (215)$$

where the b_i are the one-loop coefficients in the RGEs for the different SM couplings. Their values in the SM (on the left) and the MSSM (on the right) are:

$$\frac{4}{3}N_G - 11 \leftarrow b_3 \rightarrow 2N_G - 9 = -3 \quad (216)$$

$$\frac{1}{6}N_H + \frac{4}{3}N_G - \frac{22}{3} \leftarrow b_2 \rightarrow \frac{1}{2}N_H + 2N_G - 6 = +1 \quad (217)$$

$$\frac{1}{10}N_H + \frac{4}{3}N_G \leftarrow b_1 \rightarrow \frac{3}{10}N_H + 2N_G = \frac{33}{5} \quad (218)$$

$$\frac{23}{218} = 0.1055 \leftarrow x \rightarrow \frac{1}{7}. \quad (219)$$

Experimentally, using $\alpha_{em}(m_Z) = 1/128$, $\alpha_3 = 0.119 \pm 0.003$, $\sin^2 \theta_W(m_Z) = 0.2315$, we find

$$x = \frac{1}{6.92 \pm 0.07}, \quad (220)$$

in striking agreement with the MSSM prediction in (219)!

Another qualitative success is the prediction of the b quark mass [104, 105]. In many GUTs, such as the minimal $SU(5)$ model, discussed shortly, the b quark and the τ lepton have equal Yukawa couplings when renormalized at the GUT scale. The renormalization group then tells us that

$$\frac{m_b}{m_\tau} \simeq \left[\ln \left(\frac{m_b^2}{m_X^2} \right) \right]^{\frac{12}{33-2N_q}}. \quad (221)$$

Using $m_\tau = 1.78$ GeV, we predict that $m_b \simeq 5$ GeV, in agreement with experiment. Happily, this prediction remains successful if the effects of supersymmetric particles are included in the renormalization-group calculations [106].

To examine the GUT predictions for $\sin^2 \theta_W$ etc. in more detail, one needs to study the renormalization-group equations beyond the leading one-loop order. Through two loops, one finds that

$$Q \frac{\partial \alpha_i(Q)}{\partial Q} = -\frac{1}{2\pi} \left(b_i + \frac{b_{ij}}{4\pi} \alpha_j(Q) \right) [\alpha_i(Q)]^2, \quad (222)$$

where the b_i receive the one-loop contributions

$$b_i = \begin{pmatrix} 0 \\ -\frac{22}{3} \\ -11 \end{pmatrix} + N_g \begin{pmatrix} \frac{4}{3} \\ \frac{4}{3} \\ \frac{4}{3} \end{pmatrix} + N_H \begin{pmatrix} \frac{1}{10} \\ \frac{1}{6} \\ 0 \end{pmatrix} \quad (223)$$

from gauge bosons, N_g matter generations and N_H Higgs doublets, respectively, and at two loops

$$b_{ij} = \begin{pmatrix} 0 & 0 & 0 \\ 0 & -\frac{136}{3} & 0 \\ 0 & 0 & -102 \end{pmatrix} + N_g \begin{pmatrix} \frac{19}{15} & \frac{3}{5} & \frac{44}{15} \\ \frac{1}{5} & \frac{49}{3} & 4 \\ \frac{4}{30} & \frac{3}{2} & \frac{76}{3} \end{pmatrix} + N_H \begin{pmatrix} \frac{9}{50} & \frac{9}{10} & 0 \\ \frac{3}{10} & \frac{13}{6} & 0 \\ 0 & 0 & 0 \end{pmatrix}. \quad (224)$$

It is important to note that these coefficients are all independent of any specific GUT model, depending only on the light particles contributing to the renormalization.

Including supersymmetric particles as in the MSSM, one finds [107]

$$b_i = \begin{pmatrix} 0 \\ -6 \\ -9 \end{pmatrix} + N_g \begin{pmatrix} 2 \\ 2 \\ 2 \end{pmatrix} + N_H \begin{pmatrix} \frac{3}{10} \\ \frac{1}{2} \\ 0 \end{pmatrix}, \quad (225)$$

and

$$b_{ij} = \begin{pmatrix} 0 & 0 & 0 \\ 0 & -24 & 0 \\ 0 & 0 & -54 \end{pmatrix} + N_g \begin{pmatrix} \frac{38}{15} & \frac{6}{5} & \frac{88}{15} \\ \frac{2}{5} & 14 & 8 \\ \frac{11}{5} & 3 & \frac{68}{3} \end{pmatrix} + N_H \begin{pmatrix} \frac{9}{50} & \frac{9}{10} & 0 \\ \frac{3}{10} & \frac{7}{2} & 0 \\ 0 & 0 & 0 \end{pmatrix}, \quad (226)$$

again independent of any specific supersymmetric GUT.

One can use these two-loop equations to make detailed calculations of $\sin^2 \theta_W$ in different GUTs. These confirm that non-supersymmetric models are not consistent with the determinations of the gauge couplings from LEP and elsewhere [108]. Previously, we argued that these models predicted a wrong value for $\sin^2 \theta_W$, given the experimental value of α_3 . In Fig. 19(a) we see the converse, namely that extrapolating the experimental determinations of the α_i using the non-supersymmetric renormalization-group equations (223), (224) does not lead to a common value of the gauge couplings at any renormalization scale. In contrast, we see in Fig. 19(b) that extrapolation using the supersymmetric renormalization-group equations (225), (226) **does** lead to possible unification at $M_{GUT} \sim 10^{16}$ GeV [89], if the partners of the SM particles weigh ~ 1 TeV.

Turning this success around, and assuming $\alpha_3 = \alpha_2 = \alpha_1$ at M_{GUT} with no threshold corrections at this scale, one may estimate that [109]

$$\begin{aligned} \sin^2 \theta_W(M_Z) \Big|_{\overline{\text{MS}}} &= 0.2029 + \frac{7\alpha_{em}}{15\alpha_3} + \frac{\alpha_{em}}{20\pi} \left[-3 \ln \left(\frac{m_t}{m_Z} \right) + \frac{28}{3} \ln \left(\frac{m_{\tilde{g}}}{m_Z} \right) \right. \\ &\quad \left. - \frac{32}{3} \ln \left(\frac{m_{\tilde{W}}}{m_Z} \right) - \ln \left(\frac{m_A}{m_Z} \right) - 4 \ln \left(\frac{\mu}{m_Z} \right) + \dots \right]. \end{aligned} \quad (227)$$

Setting all the sparticle masses to 1 TeV reproduces approximately the value of $\sin^2 \theta_W$ observed experimentally. Can one invert this successful argument to estimate the supersymmetric particle mass scale? One can show [110] that the sparticle mass thresholds in (227) can be lumped into the parameter

$$T_{susy} \equiv |\mu| \left(\frac{m_{\tilde{W}}^2}{m_{\tilde{g}}^2} \right)^{14/19} \left(\frac{m_A^2}{\mu^2} \right)^{3/38} \left(\frac{m_{\tilde{W}}^2}{\mu^2} \right)^{2/19} \prod_{i=1}^3 \left(\frac{m_{\tilde{\ell}_L i}^3 m_{\tilde{q}_i}^7}{m_{\tilde{\ell}_R i}^2 m_{\tilde{u}_i}^5 m_{\tilde{d}_i}^3} \right)^{1/19}. \quad (228)$$

If one assumes sparticle mass universality at the GUT scale, then [110]

$$T_{susy} \simeq |\mu| \left(\frac{\alpha_2}{\alpha_3} \right)^{3/2} \simeq \frac{\mu}{7}, \quad (229)$$

approximately. The measured value of $\sin^2 \theta_W$ is consistent with $T_{susy} \sim 100$ GeV to 1 TeV, roughly as expected from the hierarchy argument. However, the uncertainties are such that one cannot use this consistency to constrain T_{susy} very tightly [111]. In particular, even if one accepts the universality hypothesis, there could be important model-dependent threshold corrections around the GUT scale [109, 112].

4.1.2 Specific GUTs

What groups may be used to construct a GUT [113]?

First, suitable groups must be sufficiently large to include the SM. The latter is of rank four, i.e., there are four simultaneously-diagonalizable symmetry generators²²: $SU(3)_C$ has two, $SU(2)_L$ one, and $U(1)_Y$ one also. It is striking that all of the diagonal generators are traceless: this is trivial for the non-Abelian groups $SU(3)_C$ and $SU(2)_L$, but non-trivial for $U(1)_Y$, and a possible hint that it should be embedded in a non-Abelian GUT group. Therefore, we must first find in the Cartan classification of Lie groups a group of rank higher than or equal to four. Secondly, a GUT group must possess complex representations, in order that the matter particles and their antiparticles (described by complex conjugate spinors) could be in inequivalent representations. Thirdly, we should also keep track of the hypercharges $Y = Q - T_3$. One of the major puzzles of the SM is why

$$\sum_{q,\ell} Q_i = 3Q_u + 3Q_d + Q_e = 0. \quad (230)$$

In the SM, the hypercharge assignments are *a priori* independent of the $SU(3) \times SU(2)_L$ assignments, although constrained by the fact that quantum consistency requires the resulting triangle anomalies to cancel. In a simple GUT group, the relation (230) is automatic: whenever Q is a generator of a simple gauge group, $\sum_R Q = 0$ for particles in any representation R , cf., the values of I_3 in any representation of $SU(2)$.

There are only two groups of rank 4 that have complex representations and hence are suitable *a priori* for GUTs, namely $SU(5)$ and $SU(3) \otimes SU(3)$. However, $SU(3) \otimes SU(3)$ does not allow

²²Each one is associated with a quantum number, a ‘charge’, that may be used to label particle states.

simultaneously the leptons to have an integer electric charge and the quarks to have a fractional electric charge. Moreover, if one tried to use $SU(3) \times SU(3)$, one would need to embed the electroweak gauge group in the second $SU(3)$ factor. This would be possible only if $\sum_q Q_q = 0 = \sum_\ell Q_\ell$, which is not the case for the known quarks and leptons. Therefore, attention has focused on $SU(5)$ [113] as the only possible rank-4 GUT group.

The group $SU(5)$ is the simplest GUT group capable of including the SM. Other possible GUT groups have higher rank, and groups that are commonly used are $SO(10)$, the only suitable simple group of rank 5 with complex representations, and the exceptional group E_6 of rank 6. As examples that may help understand the new physics that appears when the symmetry of the SM is enhanced, we are first going to study key aspects of the group $SU(5)$ and then, more briefly, some aspects of the group $SO(10)$.

The $SU(5)$ group

As in the SM, particles must be arranged in suitable representations of $SU(5)$. This group has a fundamental spinorial representation of dimension 5 and a 2-index antisymmetric spinorial representation of dimension 10. Together they are suitable for accommodating the fermions of a given generation, which consist of $3 \times 2 \times 2 = 12$ quarks + 2 charged leptons + 1 neutrino. To see how this may be done, we first decompose the smallest representations of $SU(5)$ in terms of representations of $SU(3) \otimes SU(2)$:

$$\bar{\mathbf{5}} = (\bar{\mathbf{3}}, \mathbf{1}) + (\mathbf{1}, \mathbf{2}), \quad (231)$$

$$\mathbf{10} = (\bar{\mathbf{3}}, \mathbf{1}) + (\mathbf{3}, \mathbf{2}) + (\mathbf{1}, \mathbf{1}). \quad (232)$$

For example, in (231) the representation $\bar{\mathbf{5}}$ of $SU(5)$ can accommodate a colour antitriplet that is also an $SU(2)$ singlet, and a colour singlet that is also an $SU(2)$ doublet. In addition, it is necessary that the sum of the charges in each of these two multiplets be zero. The only possible combination of first-generation fermions in the SM is:

$$\bar{\mathbf{5}} : (\psi_i)_L = \begin{pmatrix} \bar{d}_1 \\ \bar{d}_2 \\ \bar{d}_3 \\ e^- \\ -\nu_e \end{pmatrix}_L, \quad (233)$$

and the rest of the first-generation fermions may be accommodated uniquely, as follows:

$$\mathbf{10} : (\chi^{ij})_L = \frac{1}{\sqrt{2}} \begin{pmatrix} 0 & \bar{u}_3 & -\bar{u}_2 & u_1 & d_1 \\ -\bar{u}_3 & 0 & \bar{u}_1 & u_2 & d_2 \\ u_2 & -\bar{u}_1 & 0 & u_3 & d_3 \\ -u_1 & -u_2 & -u_3 & 0 & e^+ \\ -d_1 & -d_2 & -d_3 & -e^+ & 0 \end{pmatrix}_L, \quad (234)$$

where we neglect the eventual mixings between the fermions in different generations. We must repeat the previous classification of fermions in $\mathbf{10} + \bar{\mathbf{5}}$ representations for the other two generations: there is no explanation in $SU(5)$ for the presence of three generations²³.

After discussing the matter fermions, we now discuss the GUT gauge bosons. Groups of type $SU(N)$ have $N^2 - 1$ symmetry generators in an adjoint representation (e.g., $SU(3)_C$ has 8 gluons, $SU(2)$ has 2 W bosons, etc.), so that $SU(5)$ has 24 gauge bosons. Of these 24 gauge bosons, 12 correspond to the SM gluons, W^\pm , Z^0 and γ , and 12 are new. Decomposing this 24-dimensional adjoint representation into representations of $SU(3) \otimes SU(2) \otimes U(1)$, we find

$$\mathbf{24} = \underbrace{(\mathbf{3}, \mathbf{2}, \frac{5}{3}) \oplus (\bar{\mathbf{3}}, \mathbf{2}, -\frac{5}{3})}_{\text{new bosons}} \oplus \underbrace{(\mathbf{8}, \mathbf{1}, 0)}_{\text{gluons } G_a} \oplus \underbrace{(\mathbf{1}, \mathbf{3}, 0)}_{W_i} \oplus \underbrace{(\mathbf{1}, \mathbf{1}, 0)}_B, \quad (235)$$

²³The pairing of $\bar{\mathbf{5}}$ and $\mathbf{10}$ representations is free of triangle anomalies.

where the third numbers in the parentheses are the hypercharges of the multiplets. The new bosons, called X and Y , have electric charges $4/3$ and $2/3$, respectively, carry leptoquark quantum numbers, are coloured and have isospin $1/2$ ²⁴. In matrix notation,

$$A = \sum_{a=1}^{24} T_a A^a = \begin{pmatrix} G_i & G_i & G_i & \bar{X} & \bar{Y} \\ G_i & G_i & G_i & \bar{X} & \bar{Y} \\ G_i & G_i & G_i & \bar{X} & \bar{Y} \\ X & X & X & W_i & W_i \\ Y & Y & Y & W_i & W_i \end{pmatrix}, \quad (236)$$

where the T_a are the generators of $SU(5)$ represented by 5×5 matrices (the equivalents for $SU(5)$ of the Pauli matrices of $SU(2)$). The basis is chosen so that $SU(3)_C$ corresponds to the first three lines and columns, and $SU(2)_L$ to the last two lines. The top-left and bottom-right blocks therefore contain the gluons and W bosons, respectively, and the $U(1)$ boson B (not shown) corresponds to a traceless diagonal generator.

The remaining steps in constructing an $SU(5)$ GUT are the choices of representations for Higgs bosons, first to break $SU(5) \rightarrow SU(3) \times SU(2) \times U(1)$ and subsequently to break the electroweak $SU(2) \times U(1)_Y \rightarrow U(1)_{em}$. The simplest choice for the first stage is an adjoint $\mathbf{24}$ of Higgs bosons Φ with a v.e.v.

$$\langle 0|\Phi|0 \rangle = \begin{pmatrix} 1 & 0 & 0 & \vdots & 0 & 0 \\ 0 & 1 & 0 & \vdots & 0 & 0 \\ 0 & 0 & 1 & \vdots & 0 & 0 \\ \dots & \dots & \dots & \dots & \dots & \dots \\ 0 & 0 & 0 & \vdots & -\frac{3}{2} & 0 \\ 0 & 0 & 0 & \vdots & 0 & -\frac{3}{2} \end{pmatrix} \times \mathcal{O}(m_{GUT}). \quad (237)$$

It is easy to see that this v.e.v. preserves colour $SU(3)$, which reshuffles the first three rows and columns, weak $SU(2)$, which reshuffles the last two rows and columns, and the hypercharge $U(1)$, which is a diagonal generator. The subsequent breaking of $SU(2) \times U(1)_Y \rightarrow U(1)_{em}$ is most economically accomplished by a $\mathbf{5}$ representation of Higgs bosons H :

$$\langle 0|\phi|0 \rangle = (0, 0, 0, 0, 1) \times \mathcal{O}(m_W). \quad (238)$$

It is clear that this v.e.v. has an $SU(4)$ symmetry which yields [104] the relation $m_b = m_\tau$ before renormalization that leads, after renormalization (221), to a successful prediction for m_b in terms of m_τ . However, the same trick does not work for the first two generations, indicating a need for epicycles in this simplest GUT model [114].

Making the minimal $SU(5)$ GUT supersymmetric, as motivated by the naturalness of the gauge hierarchy, is not difficult [94]. One must replace the above GUT multiplets by supermultiplets: $\bar{\mathbf{5}} \bar{F}$ and $\mathbf{10} T$ for the matter particles, $\mathbf{24} \Phi$ for the GUT Higgs fields that break $SU(5) \rightarrow SU(3) \times SU(2) \times U(1)$. The only complication is that one needs both $\mathbf{5}$ and $\bar{\mathbf{5}}$ Higgs representations H and \bar{H} to break $SU(2) \times U(1)_Y \rightarrow U(1)_{em}$, just as two doublets were needed in the MSSM to cancel anomalies and give masses to all the matter fermions. The simplest possible form of the Higgs potential is specified by the superpotential [94]:

$$W = \left(\mu + \frac{3\lambda}{2}M\right) + \lambda\bar{H}\Phi H + f(\Phi) \quad (239)$$

²⁴They have direct interactions with quarks and leptons, which we discuss in the next section.

where $\mu = \mathcal{O}(1)$ TeV and $M = \mathcal{O}(M_{GUT})$, and $f(\Phi)$ is chosen so that $\partial f/\partial\Phi = 0$ when

$$\langle 0|\Phi|0 \rangle = M \begin{pmatrix} 1 & 0 & 0 & \vdots & 0 & 0 \\ 0 & 1 & 0 & \vdots & 0 & 0 \\ 0 & 0 & 1 & \vdots & 0 & 0 \\ \dots & \dots & \dots & \dots & \dots & \dots \\ 0 & 0 & 0 & \vdots & -\frac{3}{2} & 0 \\ 0 & 0 & 0 & \vdots & 0 & -\frac{3}{2} \end{pmatrix}. \quad (240)$$

Inserting this into the second term of (239), one finds terms $\lambda M \bar{H}_3 H_3$, $-3/2 \lambda M \bar{H}_2 H_2$ for the colour-triplet and weak-doublet components of \bar{H} and H , respectively. Combined with the bizarre coefficient of the first term, these lead to terms

$$W \ni (\mu + \frac{5\lambda}{2} M) \bar{H}_3 H_3 + \mu \bar{H}_2 H_2. \quad (241)$$

Thus we have heavy Higgs triplets with masses $\mathcal{O}(M_{GUT})$ and light Higgs doublets with masses $\mathcal{O}(\mu)$. However, this requires fine tuning the coefficient of the first term in W (239) to about 1 part in 10^{13} ! In the absence of supersymmetry, such fine tuning would be destroyed by quantum loop corrections [105].

A primary advantage of supersymmetry is that its no-renormalization theorems [80, 81] guarantee that this fine tuning is *natural*, in the sense that quantum corrections do not destroy it, unlike the situation without supersymmetry. On the other hand, supersymmetry alone does not explain the *origin* of the hierarchy. A second advantage of supersymmetry, as we saw earlier in this section, is that it would make possible a much more precise unification of the gauge couplings. However, a potential snag is that the exchanges of the supersymmetric partners of the heavy Higgs triplets \bar{H}_3, H_3 may cause rapid proton decay, as discussed later.

Another possible GUT group that is frequently studied is $SO(10)$ [113, 115]. It is a group of rank 5, that contains $SU(5) \otimes U(1)$. The principal advantage of $SO(10)$ over $SU(5)$ is that it possesses a fundamental spinorial representation of dimension 16 that can accommodate all the fermions of one generation, as well as a singlet right-handed neutrino, thanks to its decomposition in terms of $SU(5)$ representations²⁵

$$\mathbf{16} = \mathbf{10} \oplus \bar{\mathbf{5}} \oplus \mathbf{1}. \quad (242)$$

The appearance of an $SU(5)$ singlet provides a natural framework for the physics of the neutrinos and the seesaw mechanism²⁶. In $SO(10)$ the number of gauge bosons rises to 45, which includes 33 additional gauge bosons beyond the SM, and therefore many possible interactions, including additional options for proton decay. In addition, the breaking of $SO(10)$ is more complicated than that of $SU(5)$, because it is done in two steps. One may pass from $SO(10)$ to $SU(5) \otimes U(1)$ or $SU(4) \otimes SU(2)_L \otimes SU(2)_R$, and then to $SU(2) \otimes U(1)$. The Higgs sector is potentially quite extensive, and may include large multiplets of dimensions 10, 16, 45, 54, 120 and 126, depending on the model.

4.1.3 Baryon decay

Baryon instability is to be expected on general grounds, since there is no exact gauge symmetry to guarantee that baryon number B is conserved. Indeed, baryon decay is a generic prediction of GUTs, which we illustrate with the simplest $SU(5)$ model, that is anyway embedded in larger and more complicated

²⁵The $SO(10)$ group is anomaly-free, so this decomposition explains finally the freedom from anomalies of $SU(5)$ and the SM.

²⁶In $SU(5)$, singlet right-handed neutrinos could be added ‘by hand’, in which case they would have no gauge interactions. In the case of $SO(10)$, the gauge interactions of $SO(10)$ do not have any direct influence on accessible neutrino phenomenology, but may provide interesting restrictions on their Yukawa interactions.

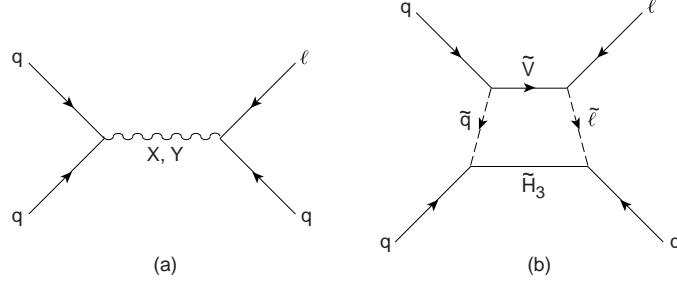

Fig. 30: Diagrams contributing to baryon decay (a) in minimal $SU(5)$ and (b) in minimal supersymmetric $SU(5)$

GUTs. We see in (236) that there are two species of gauge bosons in $SU(5)$, called X and Y , that couple the colour $SU(3)$ indices (1,2,3) to the electroweak $SU(2)$ indices (4,5). As we can see from the matter representations (234), these may enable two quarks or a quark and lepton to annihilate, as seen in Fig. 30(a). Combining these possibilities leads to an interaction with $\Delta B = \Delta L = 1$. The forms of effective four-fermion interactions mediated by the exchanges of massive Z and Y bosons, respectively, are [105]

$$\begin{aligned} & (\epsilon_{ijk} u_{Rk} \gamma_\mu u_{Lj}) \frac{g_X^2}{8m_X^2} (2e_R \gamma^\mu d_{Li} + e_L \gamma^\mu d_{Ri}) , \\ & (\epsilon_{ijk} u_{Rk} \gamma_\mu d_{Lj}) \frac{g_Y^2}{8m_X^2} (\nu_L \gamma^\mu d_{Ri}) , \end{aligned} \quad (243)$$

up to generation mixing factors.

Since the gauge couplings $g_X = g_Y = g_{3,2,1}$ in an $SU(5)$ GUT, and $m_X \simeq m_Y$, we expect that

$$G_X \equiv \frac{g_X^2}{8m_X^2} \simeq G_Y \equiv \frac{g_Y^2}{8m_Y^2}. \quad (244)$$

It is clear from (243) that the baryon decay amplitude $A \propto G_X$, and hence the baryon $B \rightarrow \ell +$ meson decay rate

$$\Gamma_B = c G_X^2 m_p^5, \quad (245)$$

where the factor of m_p^5 comes from dimensional analysis, and c is a coefficient that depends on the GUT model and the non-perturbative properties of the baryon and meson.

The decay rate (245) corresponds to a proton lifetime

$$\tau_p = \frac{1}{c} \frac{m_X^4}{m_p^5}. \quad (246)$$

It is clear from (246) that the proton lifetime is very sensitive to m_X , which must therefore be calculated very precisely. In minimal $SU(5)$, the best estimate was

$$m_X \simeq (1 \text{ to } 2) \times 10^{15} \times \Lambda_{QCD} \quad (247)$$

where Λ_{QCD} is the characteristic QCD scale in the $\overline{\text{MS}}$ prescription with four active flavours. Making an analysis of the generation mixing factors [116], one finds that the preferred proton (and bound neutron) decay modes in minimal $SU(5)$ are

$$\begin{aligned} p & \rightarrow e^+ \pi^0, \quad e^+ \omega, \quad \bar{\nu} \pi^+, \quad \mu^+ K^0, \quad \dots \\ n & \rightarrow e^+ \pi^-, \quad e^+ \rho^-, \quad \bar{\nu} \pi^0, \quad \dots, \end{aligned} \quad (248)$$

and the best numerical estimate of the lifetime is

$$\tau(p \rightarrow e^+\pi^0) \simeq 2 \times 10^{31 \pm 1} \times \left(\frac{\Lambda_{QCD}}{400 \text{ MeV}} \right)^4 y. \quad (249)$$

This is in *prima facie* conflict with the latest experimental lower limit

$$\tau(p \rightarrow e^+\pi^0) > 8.2 \times 10^{33} y \quad (250)$$

from super-Kamiokande [117]. However, this failure of minimal $SU(5)$ is not as conclusive as the failure of its prediction for $\sin^2 \theta_W$.

We saw earlier that supersymmetric GUTs, including $SU(5)$, fare better with $\sin^2 \theta_W$. They also predict a larger GUT scale [107]:

$$m_X \simeq 2 \times 10^{16} \text{ GeV}, \quad (251)$$

so that $\tau(p \rightarrow e^+\pi^0)$ is considerably longer than the experimental lower limit. However, this is not the dominant proton decay mode in supersymmetric $SU(5)$ [118]. In this model, there are important $\Delta B = \Delta L = 1$ interactions mediated by the exchange of colour-triplet higgsinos \tilde{H}_3 , dressed by gaugino exchange as seen in Fig. 30(b) [119], these give

$$G_X \rightarrow \mathcal{O} \left(\frac{\lambda^2 g^2}{16\pi^2} \right) \frac{1}{m_{\tilde{H}_3} \tilde{m}}, \quad (252)$$

where λ is a generic Yukawa coupling. Taking into account colour factors and the values of λ for more massive particles, it was found [118] that decays into neutrinos and strange particles should dominate:

$$p \rightarrow \bar{\nu}K^+, \quad n \rightarrow \bar{\nu}K^0, \quad \dots \quad (253)$$

Because there is only one factor of a heavy mass $m_{\tilde{H}_3}$ in the denominator of (252), these decay modes are expected to dominate over $p \rightarrow e^+\pi^0$ etc. in minimal supersymmetric $SU(5)$. The current experimental limit is $\tau(p \rightarrow \bar{\nu}K^+) > 10^{33}y$ [120]. Calculating carefully the other factors in (252) [121], it seems that the modes (253) may be close to detectability in this model, possibly even too close for comfort, in which case a more complicated supersymmetric GUT might be needed.

There are non-minimal supersymmetric GUT models such as flipped $SU(5)$ [122] in which the \tilde{H}_3 -exchange mechanism (252) is suppressed. In such models, $p \rightarrow e^+\pi^0$ may again be the preferred decay mode [123]. However, this is not necessarily the case, as colour-triplet Higgs boson exchange may also be important, in which case $p \rightarrow \mu^+K^0$ could be dominant [124], or there may be non-intuitive generation mixing in the couplings of the X and Y bosons, offering the possibility $p \rightarrow \mu^+\pi^0$ etc. Therefore, the continuing search for proton decay should be open-minded about the possible decay modes. The current experimental limits for these process are $\tau(p \rightarrow e^+\pi^0) > 10^{33}y$ [117], $\tau(p \rightarrow \mu^+K^0) > 10^{33}y$ [120], and $\tau(p \rightarrow \mu^+\pi^0) > 10^{33}y$ [117].

4.1.4 Neutrino masses and oscillations

The experimental upper limits on neutrino masses are far below the corresponding lepton masses [13]. From studies of the end-point of tritium β decay, we have

$$m_{\nu_e} \lesssim 2 \text{ eV}, \quad (254)$$

to be compared with $m_e = 0.511 \text{ MeV}$. Neglecting mixing effects, from studies of $\pi \rightarrow \mu\nu_\mu$ decays, we have

$$m_{\nu_\mu} < 190 \text{ keV}, \quad (255)$$

to be compared with $m_\mu = 105$ MeV, and from studies of $\tau \rightarrow$ pions + ν_τ , again neglecting mixing effects, we have

$$m_{\nu_\tau} < 18.2 \text{ MeV}, \quad (256)$$

to be compared with $m_\tau = 1.78$ GeV.

On the other hand, there is no good symmetry reason to expect the neutrino masses to vanish. We expect masses to vanish only if there is a corresponding exact gauge symmetry, cf., $m_\gamma = 0$ in QED with an unbroken $U(1)$ gauge symmetry.

However, although there is no candidate gauge symmetry to ensure $m_\nu = 0$, this is a prediction of the SM. We recall that the neutrino couplings to charged leptons take the form

$$J_\mu = \bar{e}\gamma_\mu(1 - \gamma_5)\nu_e + \bar{\mu}\gamma_\mu(1 - \gamma_5)\nu_\mu + \bar{\tau}\gamma_\mu(1 - \gamma_5)\nu_\tau, \quad (257)$$

and that only left-handed neutrinos have ever been detected. In the cases of charged leptons and quarks, their masses arise in the SM from couplings between left- and right-handed components *via* a Higgs field:

$$g_{H\bar{f}f} H_{\Delta I=\frac{1}{2}, \Delta L=0} \bar{f}_R f_L + h.c. \rightarrow m_f = g_{H\bar{f}f} \langle 0 | H_{\Delta I=\frac{1}{2}, \Delta L=0} | 0 \rangle. \quad (258)$$

Such a left–right coupling is conventionally called a Dirac mass. The following questions arise for neutrinos: if there is no ν_R , can one have $m_\nu \neq 0$? On the other hand, if there is a ν_R , why are the neutrino masses so small?

The answer to the first question is positive, because it is possible to generate neutrino masses *via* the Majorana mechanism that involves the ν_L alone. This is possible because an (\bar{f}_R) field is in fact left-handed: $(\bar{f}_R) = (f^c)_L = f_L^T C$, where the superscript T denotes a transpose, and C is a 2×2 conjugation matrix. We can therefore imagine replacing

$$(\bar{f}_R) f_L \rightarrow f_L^T C f_L, \quad (259)$$

which we denote by $f_L \cdot f_L$. In the cases of quarks and charged leptons, one cannot generate masses in this way, because $q_L \cdot q_L$ has $\Delta Q_{em}, \Delta(\text{colour}) \neq 0$ and $\ell_L \cdot \ell_L$ has $\Delta Q_{em} \neq 0$. However, the coupling $\nu_L \cdot \nu_L$ is not forbidden by such exact gauge symmetries, and would lead to a neutrino mass:

$$m^M \nu_L^T C \nu_L = m^M (\bar{\nu}^c)_L \nu_L \equiv m^M \nu_L \cdot \nu_L. \quad (260)$$

Such a combination has non-zero net lepton number $\Delta L = 2$ and weak isospin $\Delta I = 1$. There is no corresponding Higgs field in the SM or in the minimal $SU(5)$ GUT, but there is no obvious reason to forbid one. If one were present, one could generate a Majorana neutrino mass *via* the renormalizable coupling

$$\tilde{g}_{H\bar{\nu}\nu} H_{\Delta I=1, \Delta L=L} \nu_L \cdot \nu_L \Rightarrow m^M = \tilde{g}_{H\bar{\nu}\nu} \langle 0 | H_{\Delta I=1, \Delta L=2} | 0 \rangle. \quad (261)$$

However, one could also generate a Majorana mass without such an additional Higgs field, *via* a non-renormalizable coupling to the conventional $\Delta I = \frac{1}{2}$ SM Higgs field:

$$\frac{1}{M} \left(H_{\Delta I=\frac{1}{2}} \nu_L \right) \cdot \left(H_{\Delta I=\frac{1}{2}} \nu_L \right) \Rightarrow m^M = \frac{1}{M} \langle 0 | H_{\Delta I=\frac{1}{2}} | 0 \rangle^2, \quad (262)$$

where M is some (presumably heavy mass scale: $M \gg m_W$).

The simplest possibility for generating a non-renormalizable interaction of the form (262) would be *via* the exchange of a heavy field N that is a singlet of $SU(3) \times SU(2) \times U(1)$ or $SU(5)$:

$$\frac{1}{M} \rightarrow \frac{\lambda^2}{M_N}, \quad (263)$$

where one postulates a renormalizable coupling $\lambda H_{\Delta I=1/2} \nu_L \cdot N$. As already mentioned, such a heavy singlet field appears automatically in extensions of the $SU(5)$ GUT, such as $SO(10)$, though it does not actually *require* the existence of any new GUT gauge bosons.

We now have all the elements we need for the see-saw mass matrix [125] favoured by GUT model-builders:

$$(\nu_L, N) \cdot \begin{pmatrix} m^M & m^D \\ m^D & M^M \end{pmatrix} \begin{pmatrix} \nu_L \\ N \end{pmatrix}, \quad (264)$$

where the $\nu_L \cdot \nu_L$ Majorana mass m^M might arise from a $\Delta I = 1$ Higgs with coupling $\tilde{g}_{H\nu\nu}$, (261), the $\nu_L \cdot N$ Dirac mass m^D could arise from a conventional Yukawa coupling λ (263) and should be of the same order as a conventional quark or lepton mass, and M^M could *a priori* be $\mathcal{O}(M_{GUT})$ ²⁷. Diagonalizing (264) and assuming that $m^M = 0$ or that $\langle 0|H_{\Delta I=1}|0\rangle = \mathcal{O}(m_W^2/m_{GUT})$, as generically expected in GUTs, one obtains the mass eigenstates

$$\nu_L + 0 \left(\frac{m_W}{m_X} \right) N \quad : \quad m = \mathcal{O} \left(\frac{m_W^2}{M_{GUT}} \right), \quad (265)$$

$$N + 0 \left(\frac{m_W}{m_X} \right) \nu_L \quad : \quad M = \mathcal{O}(M_{GUT}). \quad (266)$$

We see that one mass eigenstate (265) is naturally much lighter than the electroweak scale, whereas the other (266) is naturally much heavier.

There is evidence for atmospheric neutrino oscillations [127] between ν_μ and ν_τ with $\Delta m_A^2 \sim (10^{-2} \text{ to } 10^{-3}) \text{ eV}^2$ and a large mixing angle: $\sin^2 \theta_{23} \gtrsim 0.9$. In addition, there is evidence [128] for solar neutrino oscillations with $\Delta m_S^2 \simeq 10^{-5} \text{ eV}^2$ and $\sin^2 \theta_{12} \sim 0.6$. We also know that the third neutrino mixing angle θ_{13} must be small, but it is an open experimental question just how small it may be. The pattern of MNS neutrino mixing seems very different from that of CKM quark mixing, perhaps reflecting special ingredients related to the see-saw mechanism. Other open questions include the magnitude of the CP-violating phase in the neutrino mixing matrix (analogous to the Kobayashi–Maskawa phase in quark mixing), and also the sequence of neutrino mass eigenstates.

CP-violating decays of heavy singlet neutrinos provide a simple mechanism for generating the baryon number of the Universe [129], by first providing a lepton asymmetry that is subsequently converted partially into a baryon asymmetry by non-perturbative electroweak interactions [15]. Essential ingredients in this scenario are the violation of lepton number *via* Majorana neutrino masses and CP violation [38]. The CP-violating phase observable in neutrino oscillations does not play a direct role in this scenario for baryogenesis [130], but its observation would nevertheless be of great conceptual importance.

4.2 Local supersymmetry and supergravity

Why study a local theory of supersymmetry [82, 83]? One motivation is the analogy with gauge theories, in which bosonic symmetries are made local. Another is that local supersymmetry necessarily involves the introduction of gravity. Since both gravity and (surely!) supersymmetry exist, this seems an inevitable step. It also leads to the possibility of unifying all the particle interactions including gravity, which was one of our original motivations for supersymmetry. Moreover, it is interesting that local supersymmetry (supergravity) admits an elegant mechanism for supersymmetry breaking [131], analogous to the Higgs mechanism in gauge theories, which allows us to address more seriously the possible existence of a cosmological constant.

²⁷It is often assumed that there are three singlet neutrinos N , but this need not be the case. If there were only two, one of the light neutrinos would be massless. On the other hand, there could be many more than three [126].

The basic building block in a supergravity theory [82, 83] is the graviton supermultiplet, which contains particles with helicities $(2, 3/2)$, the latter being the gravitino of spin $3/2$. Why is this required when one makes supersymmetry local?

We recall the basic global supersymmetry transformation laws (150, 151) for bosons and fermions. Consider now the combination of two such global supersymmetry transformations

$$[\delta_1, \delta_2] (\phi \text{ or } \psi) = -(\bar{\xi}_2 \gamma_\mu \xi_1) (i \partial_\mu) (\phi \text{ or } \psi) + \dots \quad (267)$$

The operator $(i \partial_\mu)$ corresponds to the momentum P_μ , and we see again that the combination of two global supersymmetry transformations is a translation. Consider now what happens when we consider local supersymmetry transformations characterized by a varying spinor $\xi(x)$. It is evident that the infinitesimal translation $\bar{\xi}_2 \gamma^\mu \xi_1$ in (267) is now x -dependent, and the previous global translation becomes a local coordinate transformation, as occurs in General Relativity.

How do we make the theory invariant under such local supersymmetry transformations? Consider again the simplest globally supersymmetric model containing a free spin-1/2 fermion and a free spin-0 boson (143), and make the local versions of the transformations (151), we can obtain

$$\delta \mathcal{L} = \partial_\mu (\dots) + 2\bar{\psi} \gamma_\mu \not{\partial} S(\partial^\mu \xi(x)) + \text{herm. conj.} \quad (268)$$

In contrast to the global case, the action $A = \int d^4x \mathcal{L}$ is not invariant, because of the second term in (268). To cancel it out and restore invariance, we need more fields.

We proceed by analogy with gauge theories. In order to make the kinetic term $(i\bar{\psi} \not{\partial} \psi)$ invariant under gauge transformations $\psi \rightarrow e^{i\epsilon(x)} \psi$, we need to cancel a variation

$$-\bar{\psi} \partial_\mu \psi \partial^\mu \epsilon(x), \quad (269)$$

which is done by introducing a coupling to a gauge boson

$$g\bar{\psi} \gamma_\mu \psi A^\mu(x), \quad (270)$$

and the corresponding transformation

$$\delta A_\mu(x) = \frac{1}{g} \partial_\mu \epsilon(x). \quad (271)$$

In the supersymmetric case, we cancel the second term in (268) by a coupling

$$\kappa \bar{\psi} \gamma_\mu \not{\partial} S \psi^\mu(x) \quad (272)$$

to a spin-3/2 spinor $\psi^\mu(x)$, representing a gauge fermion or gravitino, with the corresponding transformation

$$\delta \psi^\mu = -\frac{2}{\kappa} \partial^\mu \xi(x), \quad (273)$$

where $\kappa \equiv 8\pi/m_P^2$.

For completeness, let us at least write down the Lagrangian for the graviton–gravitino supermultiplet

$$L = -\frac{1}{2\kappa^2} \sqrt{-g} R - \frac{1}{2} \epsilon^{\mu\nu\rho\sigma} \bar{\psi}_\mu \gamma_5 \gamma_\nu \mathcal{D}_\rho \psi_\sigma, \quad (274)$$

where g denotes the determinant of the metric tensor

$$g_{\mu\nu} = \epsilon_\mu^m \eta_{mn} \epsilon_\nu^m, \quad (275)$$

ϵ_μ^m is the vierbein and η_{mn} the Minkowski metric tensor, and \mathcal{D}_ρ is a covariant derivative

$$\mathcal{D}_\rho \equiv \partial_\rho + \frac{1}{4} \omega_\rho^{mn} [\gamma_m, \gamma_n], \quad (276)$$

where ω_ρ^{mn} is the spin connection. This is the simplest possible generally-covariant model of a spin-3/2 field. It is remarkable that it is invariant under the local supersymmetry transformations

$$\begin{aligned}\delta\epsilon_\mu^m &= \frac{x}{2}\bar{\xi}(x)\gamma^m\psi_\mu(x), \\ \delta\omega_\mu^{mn} &= 0, \delta\psi_\mu = \frac{1}{x}\mathcal{D}_\mu\xi(x),\end{aligned}\tag{277}$$

just as the simplest possible (1/2, 0) theory (143) was globally supersymmetric, and also the action of an adjoint spin-1/2 field in a gauge theory.

As already remarked, supergravity admits an elegant analogue of the Higgs mechanism of spontaneous symmetry breaking [131]. Just as one combines the two polarization states of a massless gauge field with the single state of a massless Goldstone boson to obtain the three polarization states of a massive gauge boson, one may combine the two polarization states of a massless gravitino ψ_μ with the two polarization states of a massless Goldstone fermion λ to obtain the four polarization states of a massive spin-3/2 particle \tilde{G} . This super-Higgs mechanism corresponds to a spontaneous breakdown of local supersymmetry, since the massless graviton G has a different mass from the gravitino \tilde{G} :

$$m_G = 0 \neq m_{\tilde{G}}.\tag{278}$$

This is the only known consistent way of breaking local supersymmetry, just as the Higgs mechanism is the only way to generate $m_W \neq 0$.

Moreover, this can be achieved while keeping zero vacuum energy (cosmological constant), at least at the tree level. The reason for this is the appearance in local supersymmetry (supergravity) of a third term in the effective potential (170), which has a *negative* sign [131]. There is no time in these lectures to discuss this exciting feature in detail: the interested reader is referred to the original literature and the simplest example [132]. In this particular case, $\Lambda = V = 0$ for *any* value of the gravitino mass, for which reason it was named no-scale supergravity [133].

Again, there is no time to discuss here details of the coupling of supergravity to matter [131]. However, it is useful to have in mind the general features of the theory in the limit where $\kappa \rightarrow 0$, but the gravitino mass $m_{\tilde{G}} \equiv m_{3/2}$ remains fixed. One generally has non-zero gaugino masses $m_{1/2} \propto m_{3/2}$, and their universality is quite generic. One also has non-zero scalar masses $m_0 \propto m_{3/2}$, but their universality is much more problematic, and even violated in generic string models. It was this failing that partly refuelled interest in gauge-mediated models. A generic supergravity theory also yields non-universal trilinear soft supersymmetry-breaking couplings $A_\lambda\lambda\phi^3 : A_\lambda \propto m_{3/2}$ and bilinear scalar couplings $B_\mu\mu\phi^2 : B_\mu \propto m_{3/2}$. Therefore, supergravity may generate the full menagerie of soft supersymmetry-breaking terms:

$$-\frac{1}{2}\sum_a m_{1/2_a}\tilde{V}_a\tilde{V}_a - \sum_i m_{0_i}^2|\phi_i|^2 - \left(\sum_\lambda A_\lambda\lambda\phi^3 + \text{h.c.}\right) - \left(\sum_\mu B_\mu\mu\phi^2 + \text{h.c.}\right).\tag{279}$$

In a minimal supergravity (mSUGRA) framework, the gaugino masses $m_{1/2}$, scalar masses m_0 , and trilinear couplings A are universal, as assumed in the CMSSM, but there are specific conditions: $B = A - 1$, and the gravitino mass is fixed: $m_{3/2} = m_0$. The former condition is more restrictive than in the CMSSM, and the latter condition implies that the gravitino is the LSP in significant regions of parameter space. Hence, the CMSSM and mSUGRA are distinct scenarios [134].

Since these soft supersymmetry-breaking parameters are generated at the supergravity scale near $m_P \sim 10^{19}$ GeV, the soft supersymmetry-breaking parameters are renormalized as discussed earlier. The analogous parameters in gauge-mediated models would also be renormalized, but to a different extent, because the mediation scale $\ll m_P$. This difference may provide a signature of such models, as discussed elsewhere [135, 136].

Also renormalized is the vacuum energy (cosmological constant), which is a potential embarrassment. Loop corrections in a non-supersymmetric theory are quartically divergent, whereas those in a generic supergravity theory are only quadratically divergent, suggesting a contribution to the cosmological constant of order $m_{3/2}^2 m_P^2$, perhaps $O(10^{-32})m_P^4$. Particular models may have a one-loop quantum correction of order $m_{3/2}^4 = O(10^{-64})m_P^2$, but more magic (a new symmetry?) is needed to suppress the cosmological constant to the required level

$$\Lambda \lesssim 10^{-123} m_P^4. \quad (280)$$

This is one of the motivations for seeking a fundamental Theory of Everything including gravity.

Once upon a time, supergravity was considered a possible candidate for such a Theory of Everything, particularly the maximal $\mathcal{N} = 8$ supergravity in 4 dimensions. However, this candidature would need two elements that are still lacking: a proof that the theory is finite, or at least renormalizable, and a demonstration of how it could lead to a low-energy theory resembling the SM, e.g., *via* the formation of bound states: see Ref. [137] for a review of these issues. In the meantime, string theory [90] is the most plausible candidate for a Theory of Everything.

4.3 Towards a Theory of Everything

4.3.1 Problems in quantum gravity

One of the most important unfinished tasks for understanding the Universe and the fundamental interactions is the unification of the two great theories of the 20th century: general relativity and quantum mechanics. To write such a unified Theory of Everything is one of the major challenges for physicists in our century. The solution of the problem of the cosmological constant, for example, will have to find a place in the frame of such a Theory of Everything.

Gravity is a puzzle for conventional quantum theory, in particular because incontrollable, non-renormalizable infinities appear when one tries to calculate Feynman diagrams that contain loops with gravitons. These correction terms diverge increasingly rapidly as the order of the perturbative calculation increases, essentially because the coupling of gravity has negative mass dimensionality, being $\propto 1/M_P^2$, where $M_P \simeq 1.2 \times 10^{19}$ GeV.

There are also non-perturbative problems in the quantization of gravity, which first appeared in connection with black holes. We recall that a black hole is a non-perturbative solution of the equations of General Relativity, in which the curvature of space-time induced by gravitational forces becomes so strong that no particle can escape the event horizon. The existence of this horizon is linked to the existence of entropy S and a non-zero temperature T of the black hole. From the pioneering work of Bekenstein and Hawking [138] on black-hole thermodynamics, we know that the mass of a black hole is proportional to the surface area A of its horizon, which is related in turn to its entropy:

$$S = \frac{1}{4} A. \quad (281)$$

The appearance of non-zero entropy means that the quantum description of a black hole must involve mixed states. The intuition underlying this feature is that information can be lost through the event horizon. To see how this may happen, consider, for example, a pure quantum-mechanical pair state $|A, B\rangle \equiv \sum_i c_i |A_i\rangle |B_i\rangle$ prepared near the horizon, and what happens if one of the particles, say A , falls through the horizon while B escapes, as seen in Fig. 31. In this case, all the information about the component $|A_i\rangle$ of the wave function is lost, so that

$$\sum_i c_i |A_i B_i\rangle \rightarrow \sum_i |c_i|^2 |B_i\rangle \langle B_i| \quad (282)$$

and B emerges in a mixed state, as in Hawking's original treatment of the black-hole radiation that bears his name [138]. The problem is that conventional quantum mechanics does not permit the evolution of a pure initial state into a mixed final state.

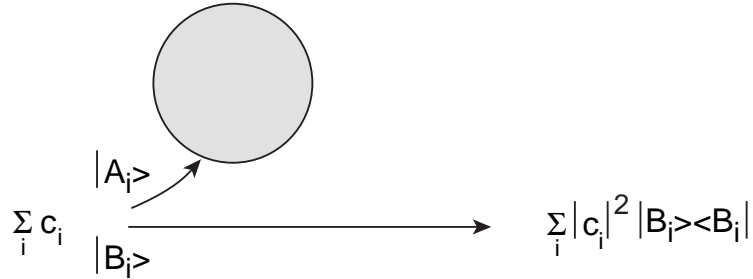

Fig. 31: If a pair of particles $|A\rangle |B\rangle$ is produced near the horizon of a black hole, and one of them ($|A\rangle$, say) falls in, the remaining particle $|B\rangle$ will appear to be in a mixed state, since the state of $|A\rangle$ is unobservable

For a discussion of these and other open problems in quantum black hole physics, see Ref. [139]. Many theorists consider that these problems point to a fundamental conflict between the proudest achievements of early-twentieth-century physics, namely quantum mechanics and General Relativity. One or the other should be modified, and perhaps both. Since quantum mechanics is sacred to field theorists, most particle physicists prefer to modify General Relativity by elevating it to string theory, as we now discuss.

4.3.2 Introduction to string theory

As was just mentioned, one of the major issues of quantum gravity is that it has an infinite number of infinities. These divergences can be traced to the absence of a short-distance cut-off in conventional field theories, where the particles are points. The problem is that one can in principle approach infinitely near a point particle, giving rise to interactions of infinite strength:

$$\int^{\Lambda \rightarrow \infty} d^4k \left(\frac{1}{k^2} \right) \leftrightarrow \int_{1/\Lambda \rightarrow 0} d^4x \left(\frac{1}{x^6} \right) \sim \Lambda^2 \rightarrow \infty. \quad (283)$$

Such divergences can be avoided or removed if one replaces point particles by extended objects. The simplest possibility is to extend in just one dimension, leading to a theory of strings. In such a theory, instead of point particles moving along one-dimensional world lines, one has strings moving over two-dimensional world sheets. Historically, closed loops of string have been the most popular, and the corresponding world sheet would be tubes. The ‘wiring diagrams’ generated by the Feynman rules of conventional point-like particle theories become ‘plumbing circuits’ generated by the junctions and connections of these tubes of closed string. One could imagine generalizing this idea to higher-dimensional extended objects such as membranes describing world volumes, etc., and we return later to this option.

Back in the early 1960s, there existed a quantum theory of the electromagnetic force (QED), but successful descriptions of the weak and strong forces were not yet known. At that time, theoretical efforts were concentrated on developing a theory that would determine the scattering (S) matrix, which describes on-mass-shell scattering amplitudes, which should possess certain properties abstracted from quantum field theory, such as unitarity and maximal analytic properties. These characteristics would ensure the requirements of causality and non-negative probabilities. A key idea in those years was maximal analyticity in the angular momentum plane, i.e., that the conventional partial-wave amplitudes $a_l(s)$ defined in the first instance for discrete angular momenta $l = 0, 1, \dots$, can be extended uniquely to analytic functions of l , $a(l, s)$. These have isolated ‘Regge’ poles that move along Regge trajectories $l = \alpha(s)$ in the complex angular-momentum plane. The values of s for which l take suitable discrete values correspond to a physical hadron states. Experimental results indicated that the Regge trajectories are approximately linear, with a common slope α' :

$$\alpha(s) = \alpha(0) + \alpha' s, \quad (284)$$

where $\alpha' \sim 1.0(\text{GeV})^{-2}$. These ideas were insufficient to determine the S matrix, and additional principles were invoked, such as the *bootstrap* idea, according to which the exchanges of hadrons in crossed channels provide forces that are responsible for forming hadronic bound states. In the narrow-resonance approximation, i.e., if resonance decay widths are negligible compared to their masses, the scattering amplitude can be expanded in an infinite series of s -channel poles, and this should give the same result as its expansion in an infinite series of t -channel poles due to exchanged particles. The narrow-resonance version of the bootstrap idea, which was called duality, had a precise formulation with a definite solution.

The decisive contribution to the solution was made by Veneziano in 1968 [140]: he gave an analytic formula that exhibited duality with linear Regge trajectories. Its structure was the sum of three Euler beta functions [141]:

$$T = A(s, t) + A(s, u) + A(t, u) : A(s, t) = \frac{\Gamma(-\alpha(s))\Gamma(-\alpha(t))}{\Gamma(-\alpha(s) - \alpha(t))}, \quad (285)$$

where α is a linear Regge trajectory, with $\alpha(s) = \alpha(0) + \alpha's$ as described above. In the course of the next few years, several further breakthroughs were achieved. Virasoro [142] showed how to generalize the Veneziano formula to one with full symmetry in the three Mandelstam invariants s, t, u . Multi-particle generalizations of the Veneziano and Virasoro formulas were constructed and shown to factorize consistently on a finite spectrum of single-particle states at each energy level, which could be described by an infinite number of simple harmonic oscillators. This surprising result led to the first ideas of strings [143]: they could be interpreted as the scattering modes of a relativistic string: open strings in the Veneziano case and closed strings in the Virasoro case²⁸.

While looking for a way to incorporate baryons into the string framework, in 1971 Ramond [75] constructed a dual-resonance model generalization of the Dirac equation. The solutions of this equation gave the spectrum of a noninteracting fermionic string. In combination with work by Neveu and Schwarz [76], this led to a unified interacting theory of bosons and fermions, which was essentially a prototype for what later came to be known as superstring theory. The action of this theory has two-dimensional global supersymmetry on the world-sheet, described by infinitesimal fermionic transformations of the type discussed in the previous Lecture.

Initially, it was regarded as a disadvantage that this first incarnation of string theory was not able to accommodate the point-like partons seen inside hadrons at this time. In retrospect, this was the converse of the quantum-gravity motivation for string theory mentioned at the beginning of this section, which disfavors point-like structures. Then in 1973 along came QCD which incorporated these point-like scaling properties and provided a qualitative understanding of confinement that has now become quantitative with the advent of modern lattice calculations. Thus string theory languished as a candidate model of the strong interactions, though there is still hope that some as yet undiscovered variant of string theory might provide a useful alternative description of the strong interactions. In the mean time, interest was sparked in 1973 by the realization that string theory predicted the existence of a massless spin-2 state [144]. Could this be the graviton? It was known that in any consistent theory of a massless spin-2 particle its low-energy interactions would be identical with those of general relativity. Might string theory be a consistent high-energy completion of this theory, in which case it might be the long-sought Theory of Everything?

As already mentioned, one of the primary reasons for studying extended objects in connection with quantum gravity is the softening of divergences associated with short-distance behaviour. Since the string propagates on a world sheet, the basic formalism is two-dimensional. Accordingly, string vibrations may be described in terms of left- and right-moving waves:

$$\phi(r, t) \rightarrow \phi_L(r - t), \phi_R(r + t). \quad (286)$$

²⁸It still seems amazing that the mathematical formulae preceded the string interpretation [141].

If the string has no boundary, as for a closed string, the left- and right-movers are independent. When quantized, they may be described by a two-dimensional field theory. Compared to a four-dimensional theory, it is relatively easy to make a two-dimensional field theory finite. In this case, it has conformal symmetry, which has an infinite-dimensional symmetry group in two dimensions. However, as you already know from gauge theories, one must be careful to ensure that this classical symmetry is not broken at the quantum level by anomalies. If the quantum string theory is to be consistent in a flat background space-time, the conformal anomaly fixes the number of left- and right-movers each to be equivalent to 26 free bosons if the theory has no supersymmetry, or 10 boson/fermion supermultiplets if the theory has $N = 1$ supersymmetry on the world sheet. There are other important quantum consistency conditions, and it was the demonstration by Green and Schwarz [145] that certain string theories are completely anomaly-free that opened the floodgates of theoretical interest in string theory as a potential Theory of Everything.

Among consistent string theories, one may enumerate the following. The *bosonic string* exists in 26 dimensions, but this is not even its worst problem! It contains no fermionic matter degrees of freedom, and the flat-space vacuum is intrinsically unstable. *Superstrings* exist in 10 dimensions, have fermionic matter and also a stable flat-space vacuum. On the other hand, the ten-dimensional theory is left-right symmetric, and the incorporation of parity violation in four dimensions is not trivial. The *heterotic string* was originally formulated in 10 dimensions, with parity violation already incorporated, since the left- and right movers were treated differently. This theory also has a stable vacuum, but still suffers from the disadvantage of having too many dimensions. *Four-dimensional heterotic strings* may be obtained either by compactifying the six surplus dimensions: $10 = 4 + 6$ compact dimensions with size $R \sim 1/m_P$, or by direct construction in four dimensions, replacing the missing dimensions by other internal degrees of freedom such as fermions or group manifolds or ...? In this way it was possible to incorporate a GUT-like gauge group [122] or even something resembling the Standard Model.

What are the general features of such string models? First, they predict there are no more than 10 dimensions, which agrees with the observed number of 4. Secondly, they suggest that the rank of the four-dimensional gauge group should not be very large, in agreement with the rank 4 of the Standard Model²⁹. Thirdly, the simplest four-dimensional string models do not accommodate large matter representations [146], such as an **8** of SU(3) or a **3** of SU(2), again in agreement with the known representation structure of the Standard Model. Fourthly, simple string models predict fairly successfully the mass of the top quark, from the requirement that the theory make sense at all energies up to the Planck mass. Fifthly, string theory makes a fairly successful prediction for the gauge unification scale in terms of m_P . If the intrinsic string coupling g_s is weak, one predicts

$$M_{GUT} = O(g) \times \frac{m_P}{\sqrt{8\pi}} \simeq \text{few} \times 10^{17} \text{GeV}, \quad (287)$$

where g is the gauge coupling, which is $\mathcal{O}(20)$ higher than the value calculated on the basis of LEP measurement of the gauge couplings. Nevertheless, it would be nice to obtain closer agreement, and this provides the major motivation for considering strongly-coupled string theory, which corresponds to a large internal dimension $l > m_{GUT}^{-1}$, as we discuss next.

4.3.3 *M theory*

As was already said, the bosonic string model has many more disadvantages than other models. It has 26 dimensions, does not contain fermions, and has an unstable vacuum. Consequently, physicists focused on superstring models, of which five types exist:

- Type IIA, that reduces at low energy to a non-chiral $N = 2$ supergravity in $d = 10$ dimensions;
- Type IIB, that reduces at low energy to a chiral $N = 2$ supergravity in $d = 10$ dimensions;

²⁹However, the number of gauge symmetries may be enhanced by non-perturbative effects.

- The heterotic $E(8) \times E(8)$ theory, that reduces at low energy to an $N = 1$ supergravity in $d = 10$, connected to a Yang–Mills gauge theory with an $E(8) \times E(8)$ gauge group;
- The heterotic theory $SO(32)$, that reduces at low energy to an $N = 1$ supergravity in $d = 10$, connected to a Yang–Mills gauge theory with an $SO(32)$ gauge group;
- Type I, that contains simultaneously opened and closed strings, and that reduces at low energy to an $N = 1$ supergravity in $d = 10$ connected to a Yang–Mills gauge theory with an $SO(32)$ gauge group.

These theories all look different. For example, the Type I theory is the only one that contains simultaneously open and closed strings, whereas the others contain only closed strings. In addition, the low-energy gauge structures of the five theories are different. It seems then, that we have five distinct theories that may describe gravity at the quantum level. How may we understand this? Is it possible that there is a link between the different theories?

Current developments involve going beyond strings to consider higher-dimensional extended objects, such as generalized membranes with various numbers of internal dimensions. These can be regarded as solitons (non-perturbative classical solutions) of string theory [147], with masses

$$m \propto \frac{1}{g_s}, \quad (288)$$

somewhat analogously to monopoles in gauge theory. It is evident from (288) that such membrane-solitons become light in the limit of strong string coupling: $g_s \rightarrow \infty$.

It was observed some time ago that there should be a strong-coupling/weak-coupling duality between elementary excitations and monopoles in supersymmetric gauge theories. These ideas were confirmed in a spectacular solution of $\mathcal{N} = 2$ supersymmetric gauge theory in four dimensions [148]. Similarly, it was shown that there are analogous dualities in string theory [149], whereby solitons in some strongly-coupled string theory are equivalent to light string states in some other weakly-coupled string theory. Indeed, it appears that all string theories are related by such dualities. A peculiarity of this discovery is that the string coupling strength g_s is related to an extra dimension in such a way that its size $R \rightarrow \infty$ as $g_s \rightarrow \infty$. This then leads to the idea of an underlying 11-dimensional framework called M theory [71] that reduces to the different string theories in different strong/weak-coupling limits, and reduces to eleven-dimensional supergravity in the low-energy limit (see Fig. 32).

A particular class of string solitons called D -branes offers a promising approach to the black hole information paradox mentioned previously. According to this picture, black holes are viewed as solitonic balls of string, and their entropy simply counts the number of internal string states. These are in principle countable, so string theory may provide an accounting system for the information contained in black holes. Within this framework, the previously paradoxical process (282) becomes

$$|A, B\rangle + |BH\rangle \rightarrow |B'\rangle + |BH'\rangle \quad (289)$$

and the final state is pure if the initial state was. The apparent entropy of the final state in (282) is now interpreted as entanglement with the state of the black hole. The ‘lost’ information is encoded in the black-hole state, and this information could in principle be extracted if we measured all properties of this ball of string [150].

In practice, we do not know how to recover this information from macroscopic black holes, so they appear to us as mixed states. What about microscopic black holes, namely fluctuations in the space-time background with $\Delta E = O(m_P)$, that last for a period $\Delta t = O(1/m_P)$ and have a size $\Delta x = O(1/m_P)$? Do these steal information from us, or do they give it back to us when they decay? Most people think there is no microscopic leakage of information in this way, but not all of us [151] are convinced. The neutral kaon system is among the most sensitive experimental areas for testing this speculative possibility.

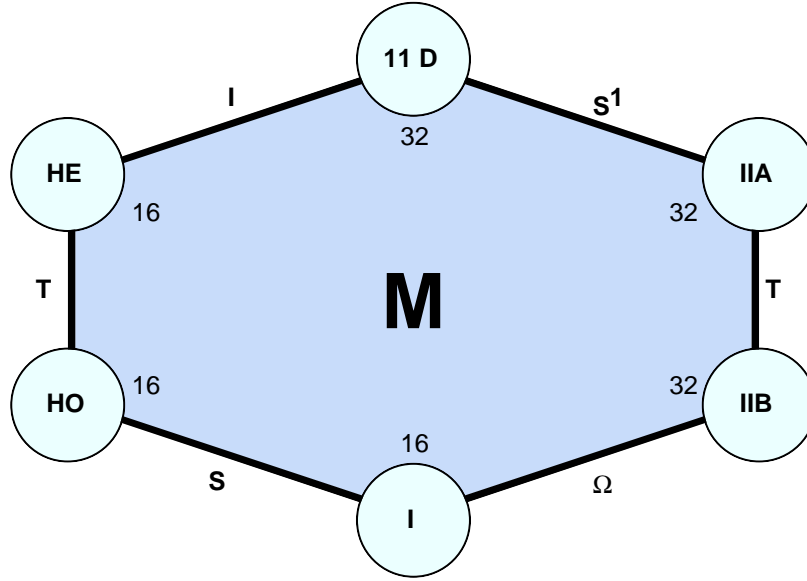

Fig. 32: The different limits of the M theory are joined by different duality relations. The numbers 16 and 32 are the numbers of spinor components in the theory.

How large might the extra dimension be in M theory? Remember that the naïve string unification scale (287) is about 20 times larger than m_{GUT} as inferred from LEP data. If one wants to maintain consistency of LEP data with supersymmetric GUTs, it seems that the extra dimension may be relatively large, with size $L_{11} \gg 1/m_{GUT} \simeq 1/10^{16}$ GeV $\gg 1/m_P$ [152]. This may be traced to the fact that the gravitational interaction strength, although growing rapidly as a power of energy

$$\sigma_G \sim E^2/m_P^4, \quad (290)$$

is still much smaller than the gauge coupling strength at $E = m_{GUT}$. However, if an extra space-time dimension appears at an energy $E < m_{GUT}$, the gravitational interaction strength grows faster, as indicated in Fig. 33. Unification with gravity around 10^{16} GeV then becomes possible, *if* the gauge couplings do not also acquire a similar higher-dimensional kick. Thus we are led to the startling capacitor-plate framework for fundamental physics shown in Fig. 34.

Each capacitor plate is *a priori* ten-dimensional, and the bulk space between them is *a priori* eleven-dimensional. Six dimensions are compactified on a scale $L_6 \sim 1/m_{GUT}$, leaving a theory which is effectively five-dimensional in the bulk and four-dimensional on the walls. Conventional gauge interactions and observable matter particles are hypothesized to live on one capacitor plate, and there are other hidden gauge interactions and matter particles living on the other plate. The fifth dimension has a characteristic size which is estimated to be $\mathcal{O}(10^{12}$ to 10^{13} GeV) $^{-1}$. Physics at smaller energies (large distances) looks effectively four-dimensional, whereas gravitational physics at larger energies (smaller distances) looks five-dimensional, and the strength of the gravitational coupling rises rapidly to unify with the gauge couplings. Supersymmetry breaking is expected to originate on the hidden capacitor plate in this scenario, and to be transmitted to the observable wall by gravitational-strength interactions in the bulk.

The phenomenological richness of this speculative M -theory approach is only beginning to be explored, and it remains to be seen whether it offers a realistic phenomenological description. However, it does embody all the available theoretical wisdom as well as offering the prospect of unifying all the observable gauge interactions with gravity at a single effective scale $\sim m_{GUT}$, including the interactions of the Standard Model. As such, it constitutes our best contemporary guess about the Theory of Everything within and beyond the Standard Model.

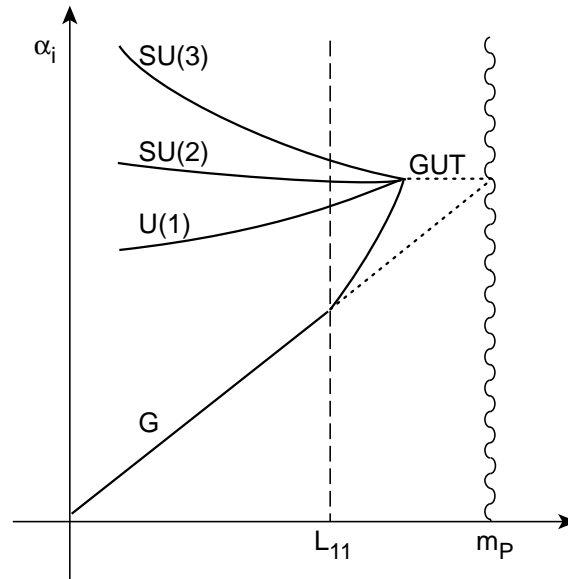

Fig. 33: Sketch of the possible evolution of the gauge couplings and the gravitational coupling G : if there is a large fifth dimension with size $\gg m_{GUT}^{-1}$, G may be unified with the gauge couplings at the GUT scale [152]

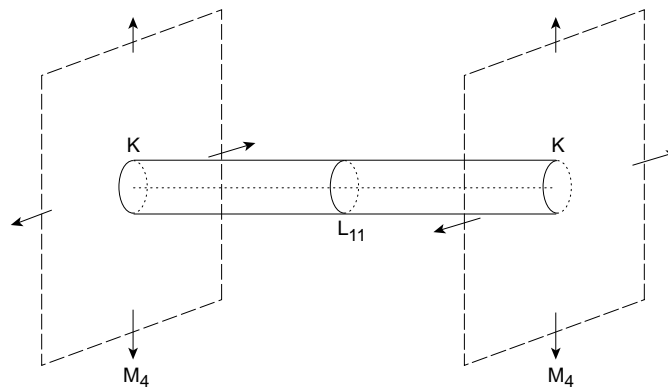

Fig. 34: The capacitor-plate scenario favoured in eleven-dimensional M theory. The eleventh dimension has a size $L_{11} \gg M_{GUT}^{-1}$, whereas dimensions 5, ..., 10 are compactified on a small manifold K with characteristic size $\sim M_{GUT}^{-1}$. The remaining four dimensions form (approximately) a flat Minkowski space M_4 [152].

4.4 Extra dimensions

We have seen that string theories suggest that there may be extra unseen dimensions of space, but this speculation did not originate with string theorists. The idea of extra dimensions was first developed by Kaluza [69] and Klein [70]. They noticed that gravitational and electromagnetic interactions, being so alike in many ways, could be descendants of a common ancestor. Indeed, if we formulate a theory with extra spatial dimensions, it is possible to unify gravity and electromagnetism. In the same way, non-Abelian gauge fields can be unified with Einstein's gravity in more complicated models with extra dimensions. Thus, the first reason why extra dimensions were studied was to unify the gravitational and gauge interactions. These initial discussions concerned gravitation at the classical level. If you want to quantize gravity, you would be well advised to look at the best available candidate, namely string or M-theory, which, as we have seen, can be formulated consistently in a space with six or seven extra dimensions. From this point of view, the quantization of gravitational interactions becomes a second reason for extra dimensions.

In all the scenarios considered above, the extra dimensions were very small, close to the Planck size or perhaps somewhat larger, but undetectable in conceivable experiments.

However, it was suggested by Antoniadis [153] that an extra dimension might be a good way to break supersymmetry, in which case its size would be $\sim 1/\text{TeV}$, in which case it might have some observable manifestations at the LHC.

Another suggestion, discussed in Lecture 2, was the possibility that boundary conditions in an extra dimension might be used to break the electroweak gauge symmetry. In this case also, the size of the extra dimension should be $\sim 1/\text{TeV}$, and potentially detectable at the LHC [66–68].

Arkani-Hamed, Dimopoulos and Dvali (ADD) [154] went even further, observing that the Higgs mass hierarchy problem might be addressed in models with large extra dimensions, if they were of a millimetre or micron in size. Because the extra dimensions are so large in the ADD framework, their effects might be measurable even in low-energy table-top experiments. These models can be embedded in string theory framework, as discussed in Ref. [155]. The main ingredients of the simplest ADD scenario are [156]:

- The particles of the SM live on a 3-brane, while gravity spreads to all $4+N$ dimensions;
- There is a new fundamental scale of gravity in extra dimensions, M_* , which together with the ultraviolet completion scale of the SM is around a few TeV or so, thus eliminating the Higgs mass hierarchy problem;
- N extra dimensions are compactified.

If we define in this context the 4-dimensional Planck mass

$$M_{Pl}^2 = M_*^{2+N} (2\pi L)^N, \quad (291)$$

and postulate that the quantum gravity scale $M_* \sim \text{TeV}$, we can estimate the size of the extra dimensions to be

$$L \sim 10^{-17+30/N} \text{cm}. \quad (292)$$

For one extra dimension, $N = 1$, we obtain $L \sim 10^{13} \text{cm}$, which is excluded within the ADD framework, because gravity would have become higher-dimensional at distances $\sim 10^{13} \text{cm}$. On the other hand, for $N = 2$ we get $L \sim 10^{-2} \text{cm}$. This case is very interesting, because it predicts a modification of the 4-dimensional laws of gravity at submillimeter distances — which has become the subject of active experimental studies [156]. For larger N , the value of L should decrease but, even for $N = 6$, L is very large compared to $1/M_P$.

Randall and Sundrum (RS) went much further still [157], showing that a model with an *infinite* warped extra dimension could provide an attractive way to reformulate the hierarchy problem. In this scenario, 4-dimensional gravity on a brane is obtained through the phenomenon of localization of gravity. The brane is embedded in a 5-dimension bulk space with negative cosmological constant. In this case we find a relation between the 4-dimensional Planck mass and M_*

$$M_{Pl}^2 = M_*^3 (2L). \quad (293)$$

This is similar to the relation between the fundamental scale M_* , the size L of the extra dimension, and the Planck mass M_P in the ADD model with one extra dimension (291). This similarity is based on the fact that in both theories the effective size of the extra dimension that is felt by the zero-mode graviton is finite and $\sim L$.

So, are extra dimensions very small, small, large or infinite, and how do we tell? There are several ways to search for extra dimensions in experiments at the TeV scale at the LHC.

Typical examples in theories with TeV-scale extra dimensions are the appearance of Kaluza–Klein excitations, corresponding to particle wave functions that wrap themselves around the extra dimension.

These show up as resonances that can appear in cross sections at specific energies related to the compactification scale. These Kaluza–Klein excitations occur in ‘towers’ that can be understood by analogy with a quantum-mechanical particle in a potential well. Its energy is quantized due to the boundary conditions at the walls of the well. In our case, the supplementary dimension plays the role of the wall of the well.

In models with very large extra dimensions, there are many Kaluza–Klein excitations of the graviton, which may be detectable *via* missing-energy events.

Another speculative possibility is the creation of a microscopic black hole [158]. Any concentration of energy or mass m will be transformed into a black hole if it is squeezed below its Schwarzschild radius: G/m . The larger the mass, the easier it can be squeezed below its Schwarzschild radius. Moreover, as we have seen, extra dimensions can increase the value of G . Hence, if there are a few extra dimensions of sufficient size, it is conceivable that collisions in the LHC might squeeze a pair of partons below their combined Schwarzschild radius, and hence create a microscopic black hole. These should evaporate rapidly, since Hawking radiation implies that the black hole loses energy at a rate inversely proportional to its mass. Studies performed by the CMS [28] and ATLAS [29] collaborations have demonstrated that such Hawking radiation would be visible in the LHC *via* energetic jets, leptons and photons, as well as missing energy carried away by neutrinos. See Fig. 35 for some results for simulated black hole production at the LHC [159].

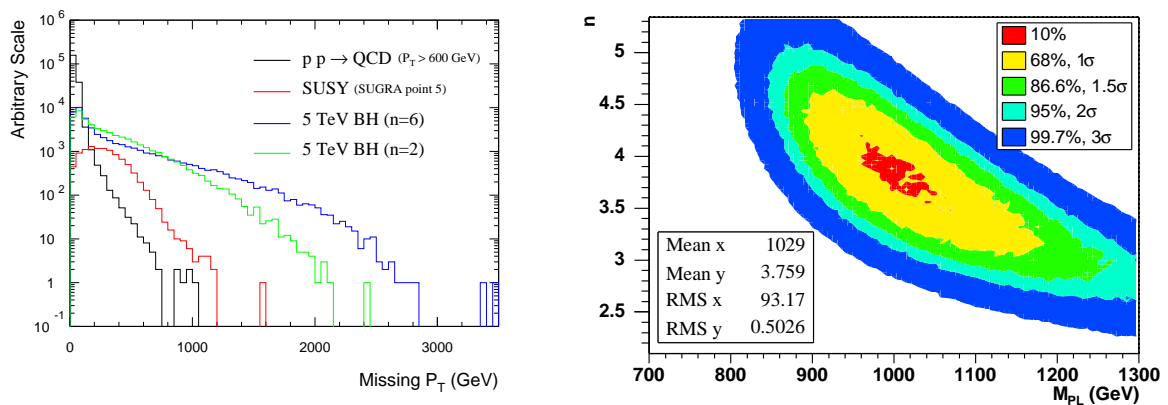

Fig. 35: Left: a comparison of the missing transverse momentum spectra in the SM, in a typical supersymmetric model, and in two black hole scenarios, and right: the results of a fit to the number of extra dimensions n and the higher-dimensional Planck mass M_{PL} on the basis of simulated black hole production at the LHC, taken from Ref. [159].

4.5 And now for something completely different?

In 1982, Prime Minister Thatcher of the United Kingdom visited CERN: I was placed in the receiving line, and introduced as a theoretical physicist. “So what do theoretical physicists *do*?” she boomed. I replied that “We think of things for the experimentalists to look for, and we hope they find something different”. Mrs Thatcher was not sure about this, and asked “Wouldn’t it be better if they found what you had predicted?” My response was that “In that case, we would not be learning anything new.” In the same spirit, let us hope that new experiments, particularly at the LHC, will soon reveal new physics beyond the Standard Model. Perhaps it will look something like the possibilities discussed in these Lectures, but let us hope that it will take us beyond the beyonds imagined by theorists.

References

- [1] P. Q. Hung and C. Quigg, *Science* **210**, 1205 (1980).

- [2] S. Weinberg, *Int. J. Mod. Phys. A* **23**, 1627 (2008).
- [3] C. Quigg, arXiv:0905.3187 [hep-ph].
- [4] F. J. Hasert *et al.* [Gargamelle Collaboration], *Phys. Lett. B* **46**, 121 (1973); *Phys. Lett. B* **46**, 138 (1973).
- [5] G. Arnison *et al.* [UA1 Collaboration], *Phys. Lett. B* **122**, 103 (1983).
- [6] M. Banner *et al.* [UA2 Collaboration], *Phys. Lett. B* **122**, 476 (1983).
- [7] P. Bagnaia *et al.* [UA2 Collaboration], *Phys. Lett. B* **129**, 130 (1983).
- [8] C. Rubbia, *Rev. Mod. Phys.* **57**, 699 (1985).
- [9] J. R. Ellis, *Beyond the Standard Model for Hill Walkers*, arXiv:hep-ph/9812235.
- [10] J. R. Ellis, *Supersymmetry for Alp Hikers*, arXiv:hep-ph/0203114.
- [11] J. Welzel, D. Gherson and J. R. Ellis, *Nouvelles Physiques des Particules*, arXiv:hep-ph/0506163.
- [12] C. Quigg, *Gauge Theories of the Strong, Weak, and Electromagnetic Interactions* (Addison-Wesley, Reading, MA, 1997).
- [13] C. Amsler *et al.* [Particle Data Group], *Phys. Lett. B* **667**, 1 (2008).
- [14] D. D. Ryutov, *Plasma Phys. Control. Fusion* **49**, B429 (2007).
- [15] G. 't Hooft, *Phys. Rev. Lett.* **37**, 8 (1976); *Phys. Rev. D* **14**, 3432 (1976) [Erratum-ibid. *D* **18**, 2199 (1978)].
- [16] ALEPH, CDF, D0, DELPHI, L3, OPAL and SLD Collaborations, LEP and Tevatron Electroweak Working Groups, SLD Electroweak and Heavy Flavour Groups, arXiv:0911.2604.
- [17] H. Flacher, M. Goebel, J. Haller, A. Hocker, K. Moenig and J. Stelzer, *Eur. Phys. J. C* **60**, 543 (2009) [arXiv:0811.0009 [hep-ph]].
- [18] J. R. Ellis and G. L. Fogli, *Phys. Lett. B* **231**, 189 (1989).
- [19] J. R. Ellis, G. L. Fogli and E. Lisi, *Phys. Lett. B* **274**, 456 (1992).
- [20] S. Schael *et al.* [ALEPH, DELPHI, L3, OPAL Collaborations and LEP Working Group for Higgs Boson Searches], *Eur. Phys. J. C* **47** (2006) 547 [arXiv:hep-ex/0602042].
- [21] B. Kayser, in the *Proceedings of 32nd SLAC Summer Institute on Particle Physics (SSI 2004): Nature's Greatest Puzzles*, Menlo Park, CA, 2004, pp. L004 [arXiv:hep-ph/0506165].
- [22] R. N. Mohapatra *et al.*, *Rep. Prog. Phys.* **70**, 1757 (2007) [arXiv:hep-ph/0510213].
- [23] B. W. Lee, C. Quigg and H. B. Thacker, *Phys. Rev. Lett.* **38**, 883 (1977); *Phys. Rev. D* **16**, 1519 (1977).
- [24] Tevatron New Phenomena & Higgs Working Group, arXiv:0911.3930; http://tevnpnwg.fnal.gov/results/SM_Higgs_Fall_09/.
- [25] J. Ellis, J. R. Espinosa, G. F. Giudice, A. Hoecker and A. Riotto, *Phys. Lett. B* **679**, 369 (2009) [arXiv:0906.0954 [hep-ph]].
- [26] J. R. Ellis and D. Ross, *Phys. Lett. B* **506**, 331 (2001) [arXiv:hep-ph/0012067].
- [27] A. Djouadi, *Phys. Rep.* **457**, 1 (2008) [arXiv:hep-ph/0503172].
- [28] G. L. Bayatian *et al.* [CMS Collaboration], *J. Phys. G* **34**, 995 (2007).
- [29] G. Aad *et al.* [The ATLAS Collaboration], arXiv:0901.0512 [hep-ex].
- [30] A. G. Riess *et al.* [Supernova Search Team Collaboration], *Astron. J.* **116**, 1009 (1998) [arXiv:astro-ph/9805201];
S. Perlmutter *et al.* [Supernova Cosmology Project Collaboration], *Astrophys. J.* **517**, 565 (1999) [arXiv:astro-ph/9812133].
- [31] A. Dobado and A. L. Maroto, *Astrophys. Space Sci.* **320**, 167 (2009) [arXiv:0802.1873 [astro-ph]].
- [32] A. Harvey, *Eur. J. Phys.* **30**, 877 (2009).

- [33] J. Dunkley *et al.* [WMAP Collaboration], *Astrophys. J. Suppl.* **180**, 306 (2009) [arXiv:0803.0586 [astro-ph]];
E. Komatsu *et al.* [WMAP Collaboration], *Astrophys. J. Suppl.* **180**, 330 (2009) [arXiv:0803.0547 [astro-ph]].
- [34] J. Ellis, J.S. Hagelin, D.V. Nanopoulos, K.A. Olive and M. Srednicki, *Nucl. Phys. B* **238**, 453 (1984);
see also H. Goldberg, *Phys. Rev. Lett.* **50**, 1419 (1983).
- [35] D. N. Spergel *et al.* [WMAP Collaboration], *Astrophys. J. Suppl.* **170**, 377 (2007) [arXiv:astro-ph/0603449].
- [36] A. D. Sakharov, *Pisma Zh. Eksp. Teor. Fiz.* **5**, 32 (1967) [*JETP Lett.* **5**, 24 (1967)].
- [37] J. M. Cline, arXiv:hep-ph/0609145.
- [38] A. Pilaftsis, *J. Phys. Conf. Ser.* **171**, 012017 (2009) [arXiv:0904.1182 [hep-ph]].
- [39] P. A. M. Dirac, *Proc. Roy. Soc. Lond. A* **133**, 60 (1931).
- [40] P. A. M. Dirac, *Phys. Rev.* **74**, 817 (1948).
- [41] P. A. M. Dirac, in *Proceedings Orbis Scientiae: New Pathways in High-Energy Physics*, Coral Gables, 1976, Vol. I, A. Perlmutter (ed.) (Plenum, New York, 1976), pp. 1–14.
- [42] B. Cabrera, *Phys. Rev. Lett.* **48**, 1378 (1982).
- [43] J. H. Schwarz and N. Seiberg, *Rev. Mod. Phys.* **71**, S112 (1999) [arXiv:hep-th/9803179].
- [44] A. Ashtekar, *Nuovo Cim.* **122B**, 135 (2007) [arXiv:gr-qc/0702030].
- [45] K. D. Lane, arXiv:hep-ph/9401324.
- [46] J. F. Gunion, H. E. Haber, G. Kane, and S. Dawson, *The Higgs Hunter's Guide* (Perseus Publishing, New York, 1990).
- [47] M. S. Chanowitz, *Phys. Rev. D* **66**, 073002 (2002) [arXiv:hep-ph/0207123].
- [48] G. P. Zeller *et al.* [NuTeV Collaboration], *Phys. Rev. Lett.* **88**, 091802 (2002) [Erratum-ibid. **90**, 239902 (2003)] [arXiv:hep-ex/0110059].
- [49] R. Barbieri and A. Strumia, arXiv:hep-ph/0007265.
- [50] For a review of little Higgs models, see M. Schmaltz and D. Tucker-Smith, *Annu. Rev. Nucl. Part. Sci.* **55**, 229 (2005) [arXiv:hep-ph/0502182].
- [51] N. Arkani-Hamed, A. G. Cohen and H. Georgi, *Phys. Lett. B* **513**, 232 (2001) [arXiv:hep-ph/0105239].
- [52] H. C. Cheng and I. Low, *JHEP* **0408**, 061 (2004) [arXiv:hep-ph/0405243].
- [53] M. Perelstein, *Prog. Part. Nucl. Phys.* **58**, 247 (2007) [arXiv:hep-ph/0512128].
- [54] E. Farhi and L. Susskind, *Phys. Rept.* **74**, 277 (1981).
- [55] C. T. Hill and E. H. Simmons, *Phys. Rep.* **381**, 235 (2003) [Erratum-ibid. **390**, 553 (2004)] [arXiv:hep-ph/0203079].
- [56] S. Weinberg, *Phys. Rev. D* **19**, 1277 (1979).
- [57] L. Susskind, *Phys. Rev. D* **20**, 2619 (1979).
- [58] A. Martin, arXiv:0812.1841 [hep-ph].
- [59] J. Bardeen, L. N. Cooper and J. R. Schrieffer, *Phys. Rev.* **108**, 1175 (1957).
- [60] T. Appelquist, M. Piai and R. Shrock, *Phys. Rev. D* **69**, 015002 (2004) [arXiv:hep-ph/0308061].
- [61] S. Dimopoulos and J. R. Ellis, *Nucl. Phys. B* **182**, 505 (1982).
- [62] J. R. Ellis, M. K. Gaillard, D. V. Nanopoulos and P. Sikivie, *Nucl. Phys. B* **182**, 529 (1981).
- [63] J. R. Ellis, G. L. Fogli and E. Lisi, *Phys. Lett. B* **343**, 282 (1995).
- [64] M. T. Frandsen, arXiv:0710.4333 [hep-ph].
- [65] R. Contino, C. Grojean, M. Moretti, F. Piccinini and R. Rattazzi, in preparation.

- [66] S. K. Rai, *Int. J. Mod. Phys. A* **23**, 823 (2008) [arXiv:hep-ph/0510339].
- [67] R. Barbieri, G. Marandella and M. Papucci, *Phys. Rev. D* **66**, 095003 (2002) [arXiv:hep-ph/0205280].
- [68] J. F. Gunion and B. Grzadkowski, arXiv:hep-ph/0004058.
- [69] Th. Kaluza, *Sitzungsber. Preuss. Akad. Wiss. Phys. Math. Klasse* 996 (1921); Reprinted with an English translation in *Modern Kaluza–Klein Theories*, eds. T. Appelquist, A. Chodos and P.G.O. Freund (Addison-Wesley, Menlo Park, 1987).
- [70] O. Klein, *Z. Phys.* **37**, 895 (1926); Reprinted with an English translation in *Modern Kaluza–Klein Theories*, eds. T. Appelquist, A. Chodos and P.G.O. Freund (Addison-Wesley, Menlo Park, 1987).
- [71] For a review, see: Miao Li, hep-th/9811019.
- [72] H. C. Cheng, arXiv:0710.3407 [hep-ph].
- [73] S. R. Coleman and J. Mandula, *Phys. Rev.* **159**, 1251 (1967).
- [74] Yu. A. Golfand and E. P. Likhtman, *JETP Lett.* **13**, 323 (1971) [*Pisma Zh. Eksp. Teor. Fiz.* **13**, 452 (1971)].
- [75] P. Ramond, *Phys. Rev. D* **3**, 2415 (1971).
- [76] A. Neveu and J. H. Schwarz, *Nucl. Phys. B* **31**, 86 (1971).
- [77] D. V. Volkov and V. P. Akulov, *Phys. Lett. B* **46**, 109 (1973).
- [78] J. Wess and B. Zumino, *Phys. Lett. B* **49**, 52 (1974); *Nucl. Phys. B* **70**, 39 (1974).
- [79] J. Wess and B. Zumino, *Nucl. Phys. B* **78**, 1 (1974).
- [80] J. Iliopoulos and B. Zumino, *Nucl. Phys.* **B76**, 310 (1974).
- [81] S. Ferrara, J. Iliopoulos and B. Zumino, *Nucl. Phys.* **77**, 413 (1974).
- [82] D. Z. Freedman, P. van Nieuwenhuizen and S. Ferrara, *Phys. Rev.* **D13**, 3214 (1976).
- [83] S. Deser and B. Zumino, *Phys. Lett.* **62B**, 335 (1976).
- [84] P. Fayet and S. Ferrara, *Phys. Rep.* **32**, 249 (1977).
- [85] H. P. Nilles, *Phys. Rep.* **110**, 1 (1984).
- [86] H. E. Haber and G. L. Kane, *Phys. Rep* **117**, 75 (1985).
- [87] S. P. Martin, *A Supersymmetry Primer*, arXiv:hep-ph/9709356.
- [88] Y. Okada, M. Yamaguchi and T. Yanagida, *Prog. Theor. Phys.* **85**, 1 (1991);
J. R. Ellis, G. Ridolfi and F. Zwirner, *Phys. Lett. B* **257**, 83 (1991);
H. E. Haber and R. Hempfling, *Phys. Rev. Lett.* **66**, 1815 (1991).
- [89] J. Ellis, S. Kelley and D.V. Nanopoulos, *Phys. Lett.* **260**, 131 (1991);
U. Amaldi, W. de Boer and H. Furstenau, *Phys. Lett.* **B260**, 447 (1991);
P. Langacker and M. Luo, *Phys. Rev.* **D44**, 817 (1991);
C. Giunti, C. W. Kim and U. W. Lee, *Mod. Phys. Lett. A* **6**, 1745 (1991).
- [90] M. B. Green, J. H. Schwarz and E. Witten, *Superstring Theory* (Cambridge Univ. Press, 1987).
- [91] H. N. Brown *et al.* [Muon g-2 Collaboration], *Phys. Rev. Lett.* **86**, 2227 (2001) [arXiv:hep-ex/0102017].
- [92] M. Davier, A. Hoecker, B. Malaescu, C. Z. Yuan and Z. Zhang, arXiv:0908.4300 [hep-ph].
- [93] J. R. Ellis, J. F. Gunion, H. E. Haber, L. Roszkowski and F. Zwirner, *Phys. Rev. D* **39**, 844 (1989).
- [94] S. Dimopoulos and H. Georgi, *Nucl. Phys.* **B193**, 150 (1981).
- [95] R. Barbieri *et al.*, arXiv:hep-ph/0406039.
- [96] J. R. Ellis, J. S. Lee and A. Pilaftsis, *Phys. Rev. D* **76**, 115011 (2007) [arXiv:0708.2079 [hep-ph]].
- [97] M. Carena, J. R. Ellis, A. Pilaftsis and C. E. Wagner, *Nucl. Phys. B* **586**, 92 (2000) [arXiv:hep-ph/0003180], *Phys. Lett. B* **495**, 155 (2000) [arXiv:hep-ph/0009212]; and references therein.
- [98] J. R. Ellis, K. A. Olive, Y. Santoso and V. C. Spanos, *Phys. Lett. B* **565**, 176 (2003) [arXiv:hep-

- ph/0303043].
- [99] O. Buchmueller *et al.*, arXiv:0907.5568 [hep-ph].
- [100] T. Hahn, S. Heinemeyer, W. Hollik, H. Rzehak and G. Weiglein, *Comput. Phys. Commun.* **180**, 1426 (2009).
- [101] O. Buchmueller *et al.*, *JHEP* **0809**, 117 (2008) [arXiv:0808.4128 [hep-ph]].
- [102] H. Georgi, H. Quinn and S. Weinberg, *Phys. Rev. Lett.* **33**, 451 (1974).
- [103] J. Ellis and D.V. Nanopoulos, *Nature* **292**, 436 (1981).
- [104] M. Chanowitz, J. Ellis and M. K. Gaillard, *Nucl. Phys.* **B128**, 506 (1977).
- [105] A. J. Buras, J. Ellis, M. K. Gaillard and D. V. Nanopoulos, *Nucl. Phys.* **B135**, 66 (1978).
- [106] D. V. Nanopoulos and D. A. Ross, *Phys. Lett.* **118B**, 99 (1982).
- [107] S. Dimopoulos and H. Georgi [94];
S. Dimopoulos, S. Raby and F. Wilczek, *Phys. Rev.* **D24**, 1681 (1981);
L. Ibàñez and G. G. Ross, *Phys. Lett.* **105B**, 439 (1981).
- [108] J. Ellis, S. Kelley and D. V. Nanopoulos, *Phys. Lett.* **B249**, 441 (1990).
- [109] J. Ellis, S. Kelley and D. V. Nanopoulos, *Nucl. Phys.* **B373**, 55 (1992).
- [110] P. Langacker and N. Polonsky, *Phys. Rev.* **D47**, 4028 (1993).
- [111] F. Anselmo, L. Cifarelli, A. Peterman and A. Zichichi, *Nuovo Cimento* **104A**, 1817 (1991);
F. Anselmo, L. Cifarelli, A. Peterman and A. Zichichi, *Nuovo Cimento* **105A**, 1210 (1992).
- [112] R. Barbieri and L. J. Hall, *Phys. Rev. Lett.* **68**, 752 (1992);
J. Hisano, T. Moroi, K. Tobe and T. Yanagida, *Phys. Lett.* **B342**, 138 (1995).
- [113] H. Georgi and S. L. Glashow, *Phys. Rev. Lett.* **32**, 438 (1974).
- [114] J. Ellis and M. K. Gaillard, *Phys. Lett.* **88B**, 315 (1979).
- [115] H. Fritzsch and P. Minkowski, *Ann. Phys. (N.Y.)* **93**, 193 (1975).
- [116] J. Ellis, M. K. Gaillard and D. V. Nanopoulos, *Phys. Lett.* **91B**, 67 (1980).
- [117] H. Nishino *et al.* [Super-Kamiokande Collaboration], *Phys. Rev. Lett.* **102**, 141801 (2009) [arXiv:0903.0676 [hep-ex]].
- [118] J. Ellis, D. V. Nanopoulos and S. Rudaz, *Nucl. Phys.* **B202**, 43 (1982);
S. Dimopoulos, S. Raby and F. Wilczek, *Phys. Lett.* **112B**, 133 (1982).
- [119] S. Weinberg, *Phys. Rev.* **D26**, 287 (1982),
N. Sakai and T. Yanagida, *Nucl. Phys.* **B197**, 533 (1982).
- [120] K. Kobayashi *et al.* [Super-Kamiokande Collaboration], *Phys. Rev. D* **72**, 052007 (2005) [arXiv:hep-ex/0502026].
- [121] J. Ellis, D. V. Nanopoulos and S. Rudaz, *Nucl. Phys.* **B202**, 43 (1982).
- [122] I. Antoniadis, J. Ellis, J. S. Hagelin and D. V. Nanopoulos, *Phys. Lett.* **B194**, 231 (1987) and **B231**, 65 (1989).
- [123] J. Ellis, J. S. Hagelin, S. Kelley and D. V. Nanopoulos, *Nucl. Phys.* **B311**, 1 (1988).
- [124] B. A. Campbell, J. Ellis and S. Rudaz, *Phys. Lett.* **141B**, 229 (1984).
- [125] T. Yanagida, *Proc. Workshop on Unified Theories and Baryon Number in the Universe*, Tsukuba, Japan, 1979 (KEK, Japan, 1979, report KEK-79-18);
R. Slansky, Talk at the *Sanibel Symposium*, Palm Coast, FL, USA, 1979, Caltech preprint CALT-68-709 (1979).
- [126] J. R. Ellis and O. Lebedev, *Phys. Lett. B* **653**, 411 (2007) [arXiv:0707.3419 [hep-ph]].
- [127] Y. Fukuda *et al.* [Super-Kamiokande Collaboration], *Phys. Rev. Lett.* **81**, 1562 (1998).
- [128] Q. R. Ahmad *et al.* [SNO Collaboration], *Phys. Rev. Lett.* **89**, 011301 (2002) [arXiv:nucl-ex/0204008].

- [129] M. Fukugita and T. Yanagida, *Phys. Lett. B* **174**, 45 (1986).
- [130] J. R. Ellis and M. Raidal, *Nucl. Phys. B* **643**, 229 (2002) [arXiv:hep-ph/0206174].
- [131] J. Polonyi, Hungary Central Inst. Res., KFKI-77-93;
E. Cremmer, B. Julia, J. Scherk, S. Ferrara, L. Girardello and P. Van Nieuwenhuizen, *Nucl. Phys. B* **147**, 105 (1979).
- [132] E. Cremmer, S. Ferrara, C. Kounnas and D.V. Nanopoulos, *Phys. Lett.* **133B**, 61 (1983).
- [133] J. Ellis, A.B. Lahanas, D.V. Nanopoulos and K.A. Tamvakis, *Phys. Lett.* **134B**, 429 (1984).
- [134] J. R. Ellis, K. A. Olive, Y. Santoso and V. C. Spanos, *Phys. Rev. D* **70**, 055005 (2004) [arXiv:hep-ph/0405110].
- [135] A. Strumia, *Phys. Lett.* **B409**, 213 (1997).
- [136] J. R. Ellis, K. A. Olive and P. Sandick, *Phys. Lett. B* **642**, 389 (2006) [arXiv:hep-ph/0607002]; *JHEP* **0706**, 079 (2007) [arXiv:0704.3446 [hep-ph]]; *JHEP* **0808**, 013 (2008) [arXiv:0801.1651 [hep-ph]].
- [137] J. Alexandre, J. Ellis and N. E. Mavromatos, arXiv:0901.2532 [hep-th].
- [138] J. Bekenstein, *Phys. Rev.* **D12**, 3077 (1975);
S. Hawking, *Commun. Math. Phys.* **43**, 199 (1975).
- [139] A. Strominger, arXiv:0906.1313 [hep-th].
- [140] G. Veneziano, *Nuovo Cimento* **57A**, 190 (1968) and *Phys. Rep.* **C9**, 199 (1974).
- [141] J. H. Schwarz, arXiv:0708.1917 [hep-th].
- [142] M. A. Virasoro, *Phys. Rev.* **177**, 2309 (1969).
- [143] Y. Nambu, *Proc. Int. Conf. on Symmetries and Quark Models*, Wayne State University, Detroit, MI, USA, 1969 (Gordon and Breach, New York, 1970), p. 269;
P. Goddard, J. Goldstone, C.Rebbi and C. Thorn, *Nucl. Phys.* **B181**, 502 (1981).
- [144] J. Scherk and J. H. Schwarz, *Nucl. Phys. B* **81**, 118 (1974).
- [145] M.B. Green and J.H. Schwarz, *Phys. Lett.* **149B**, 117 (1984) and **151B**, 21 (1985).
- [146] H. Dreiner, J. Lopez, D. V. Nanopoulos and D. B. Reiss, *Phys. Lett.* **B216**, 283 (1989).
- [147] J. Polchinski, *Phys. Rev. Lett.* **75**, 4724 (1995) [arXiv:hep-th/9510017].
- [148] N. Seiberg and E. Witten, *Nucl. Phys. B* **426**, 19 (1994) [Erratum-ibid. *B* **430**, 485 (1994)] [arXiv:hep-th/9407087].
- [149] C. M. Hull and P. K. Townsend, *Nucl. Phys. B* **438**, 109 (1995) [arXiv:hep-th/9410167].
- [150] For a recent take on this, see S. B. Giddings, arXiv:0911.3395 [hep-th].
- [151] J. Ellis, N. E. Mavromatos and D. V. Nanopoulos, *Mod. Phys. Lett.* **A10**, 425 (1995) and references therein.
- [152] P. Horava and E. Witten, *Nucl. Phys.* **B460**, 506 (1996) and *Nucl. Phys.* **B475**, 94 (1996);
P. Horava, *Phys. Rev.* **D54**, 7561 (1996).
- [153] I. Antoniadis, *Phys. Lett. B* **246**, 377 (1990).
- [154] N. Arkani-Hamed, S. Dimopoulos and G. R. Dvali, *Phys. Lett. B* **429**, 263 (1998) [arXiv:hep-ph/9803315]; N. Arkani-Hamed, S. Dimopoulos and G. R. Dvali, *Phys. Rev. D* **59**, 086004 (1999) [arXiv:hep-ph/9807344].
- [155] I. Antoniadis, N. Arkani-Hamed, S. Dimopoulos and G. R. Dvali, *Phys. Lett. B* **436**, 257 (1998) [arXiv:hep-ph/9804398].
- [156] G. Gabadadze, arXiv:hep-ph/0308112.
- [157] L. Randall and R. Sundrum, *Phys. Rev. Lett.* **83**, 4690 (1999) [arXiv:hep-th/9906064].
- [158] S. B. Giddings and S. D. Thomas, *Phys. Rev. D* **65**, 056010 (2002) [arXiv:hep-ph/0106219];
S. Dimopoulos and G. L. Landsberg, *Phys. Rev. Lett.* **87**, 161602 (2001) [arXiv:hep-ph/0106295].

- [159] C. M. Harris, M. J. Palmer, M. A. Parker, P. Richardson, A. Sabetfakhri and B. R. Webber, JHEP **0505**, 053 (2005) [arXiv:hep-ph/0411022].