

EXPERIENCE WITH THE LHC BEAM DUMP POST-OPERATIONAL CHECKS SYSTEM

J. Uythoven, J. Axensalva, V. Baggiolini, E. Carlier, E. Gallet, B. Goddard, V. Kain, M. Lamont, N. Magnin, Geneva, Switzerland

Abstract

After each beam dump in the LHC automatic post-operational checks are made to guarantee that the last beam dump has been executed correctly and that the system can be declared to be ‘as good as new’ before the next injection is allowed. The analysis scope comprises the kicker waveforms, redundancy in kicker generator signal paths and different beam instrumentation measurements. This paper describes the implementation and the operational experience of the internal and external post-operational checks of the LHC beam dumping system during the commissioning of the LHC without beam and during the first days of beam operation.

INTRODUCTION

The LHC Beam Dumping System [1] was installed towards the end of 2007. For each of the two beams the nominal system consists of 15 horizontal kickers which extract the beam, 15 vertically deflecting extraction septa and 10 dilution kickers which deflect the beam in both transverse planes. After dilution the beam describes an ‘e-like’ figure on the face of the beam dump block, installed at the end of the 700 m long extraction channel. The beam diagnostics consists of several BTV screens, beam position monitors and beam loss monitors, distributed over the extraction straight section and the beam dump channel. Fixed and movable absorbers are installed in the injection straight section to protect the machine against a beam dump which is not synchronised with the beam free abort gap of 3 μ s.

The LHC beams, with a nominal intensity of $3.2 \cdot 10^{14}$ protons per beam and a beam energy of 7 TeV, incorporate an unprecedented stored energy of more than 350 MJ per beam. The only way to safely deposit this energy in case of emergencies, or at the end of a physics run, is via the beam dump system. The beam dump system is classified as safety critical and has to comply with Safety and Integrity Level 4 (SIL4). SIL4 was confirmed by a detailed study [2], under the assumption that at the start of each physics fill the beam dumping system can be confirmed to be ‘as good as new’. To assure this a detailed, automatic analysis of each beam dump is executed which inhibits all LHC beams if the analysis does not comply with the references defined.

THE IPOC SYSTEM

The most critical elements of the beam dumping system are the extraction and dilution kickers. All pulsed signals of these systems are automatically analysed by the Internal Post Operational Check (IPOC) system after each beam dump. It is composed of three sub-systems: the

IPOC FAAS which analyses the current waveform of each kicker, the IPOC TSDS which checks all events regarding dump requests, and the IPOC SCSS which checks the redundancy of the signal paths and centralises all IPOC sub-systems status information.

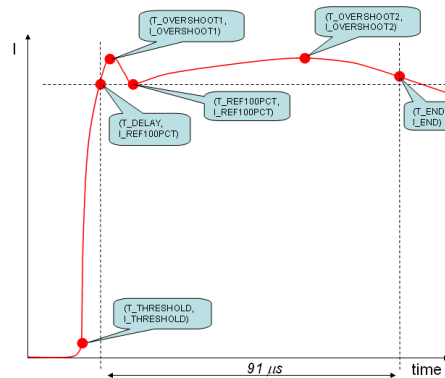

Figure 1: Description of the characteristic points of the extraction kicker current waveform.

IPOC FAAS

After each dump the Fast Acquisition and Analysis System (FAAS) performs the acquisition and analysis of the waveforms of the 30 extraction kickers and 20 dilution kickers. The analysis consists of the comparison of the defined characteristic points with reference values, as shown in Fig. 1.

The hardware is based on a 21-slot Wiener Compact-PCI 6U crate, equipped with a Concurrent Technologies CPU board running Scientific Linux CERN 5. A CERN Timing Receiver Card is mounted on the CPU controller, and connected to the CERN Central Timing System. The waveforms are acquired using National Instrument PXI-5122 digitizers (2 channels, 14 bits, 100 MS/s) that guarantee a 50 MHz bandwidth, and a 60 dB Signal-to-Noise ratio. The IPOC FAAS will generate status signals for the SCSS, described below.

IPOC TSDS:

The Trigger Synchronisation and Distribution System (TSDS) [3] receives the dump requests from three different sources: The machine protection system for emergencies, the machine timing system for scheduled dumps, and the LBDS itself in case of an internal fault. The Trigger Synchronisation Unit board receives these requests and issues a dump trigger that is synchronised with respect to the beam abort gap. TSDS IPOC is a real-time application that checks, after each dump, that all

these events were received in the right order, and that they were correctly synchronized with each other.

IPOC SCSS:

The IPOC State Control and Surveillance System (SCSS) [3] of each generator checks that all redundant signals have correctly been received, like trigger inputs, power triggers outputs, re-trigger line inputs, etc. The SCSS is based on a fail-safe, multi-master PLC architecture, using Siemens SIMATIC S7 PLC family. Each generator has a 'slave' and a 'master' PLC. The 'slave' executes the IPOC of its transient pulse signals activated during the beam dump process. The 'master' PLC collects the IPOC results from all 'slave' PLCs and the status of all IPOC FAAS and IPOC TSDS Systems. It monitors the statuses of all IPOC sub-systems, and is responsible for the final arming of the LBDS.

THE XPOC SYSTEM

To make the analysis redundant, the extraction and dilution kicker waveforms are analysed a second time by the eXternal Operation Check system (XPOC) [4]. The difference to the IPOC FAAS is that individual references are defined for each extraction and dilution magnet and the limits are set tighter. In addition to the waveforms the XPOC system also analyses the following measurements taken by the beam instrumentation:

- The beam position in the extraction channel;
- The beam image on the BTV screen just in front of the beam dump block;
- The beam intensities in the dump channel compared to the circulating and injected beam intensities;
- Beam losses in the extraction channel and at the collimators distributed over the machine;
- The beam population of the abort gap;
- The vacuum pressure in the extraction channel.

The analysis a) and b) depend on the filling pattern of the machine which is taken into account for the analysis. The analysis of the kicker waveforms depends on the beam energy. The analysis of the beam loss signals depends on the beam energy and the beam intensity.

XPOC Implementation

The XPOC is implemented with the standard tools and infrastructure used for CERN accelerator controls (Java, Swing, the Spring Framework and the Controls Middleware, CMW). Fig. 2 explains the functionality of the system. When the XPOC server receives a beam dump event from the timing system (1), it acquires raw data from the Kicker IPOC and the beam instrumentation devices (2) and executes the analysis routines (3). It then logs the results into the LHC logging system and notifies the XPOC GUI and the LHC sequencer (4). If no analysis error is found, the XPOC server returns "Finished OK" to the LHC sequencer, which then automatically arms the XPOC server again, making it ready for the next dump event. If anything fails during the XPOC (acquisition, analysis, etc.) the XPOC returns "Finished FAULT" to the

sequencer. In the latter case, the sequencer inhibits beam injection.

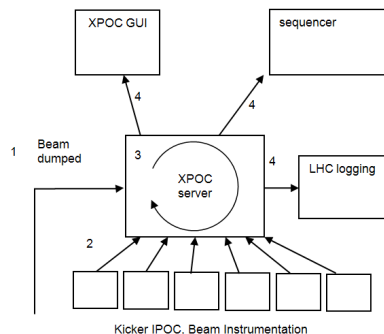

Figure 2: Description of the XPOC system.

GENERATION OF KICKER SYSTEM REFERENCES

The IPOC and XPOC references are automatically generated after a so called 'calibration run', during which the systems are pulsed at 18 predefined energies between 400 GeV and 7100 GeV. At each energy level the system is pulsed 5 times and the characteristic points of each waveform are calculated. For each system and energy an average value and variance are calculated. For the IPOC systems averages and min/max values are calculated over the different energies and systems. The advantage is that the IPOC references are relatively simple with only six files of about 10 lines with single values and their description for all the kicker systems. However, the tolerance windows are rather large, like for the extraction system $\pm 4.5\%$ on the kick amplitude and ± 600 ns on the delay and the rise time.

The XPOC kicker references are calculated from the same calibration data, for each of the 18 reference energies and individually for each kicker system. The results are again combined in six files, but as an example, for the extraction kicker system the XPOC reference contains 3240 lines. The tolerance on the amplitude is $\pm 1.0\%$ and on the rise time and delay ± 50 ns. The tolerances on the overshoots, see Fig. 1, are $\pm 0.5\%$.

OPERATIONAL EXPERIENCE

Kicker Systems

Operation of the beam dump system kickers in 'local mode' started in November 2007, followed by the reliability run [5] and the so called 'dry runs' from the central CERN control room during 2008. Operation with beam took place between 10th and 19th September 2008. In this period 741'057 waveforms were analysed by the IPOC and XPOC systems. As the tolerance windows on the IPOC system are relative large, no IPOC errors were recorded.

The study of the logged amplitudes for the different energies resulted in the discovery of a temperature effect of the solid state switches [5] and a small number of

switch failures according to expectations (which would not have affected the beam due to the switch redundancy).

The XPOC analysis with its very tight limits proved highly useful to detect a problem after an intervention on the kickers, which might otherwise have gone unnoticed. The XPOC reported a 'Finished Fault' status, which was finally tracked down to two power trigger cables that were badly connected. Due to the redundancy, there are in total four power trigger cables for two switches, the systems continued to pulse apparently correctly. There were however small changes in rise time, see Fig. 3, and in system delay of the order of the applied tolerances of ± 50 ns. In the figure the blue and grey points are for the two systems with the badly connected cables, the red and green points are for two arbitrarily chosen systems. The plotted data is filtered on the beam energy. As the rise time changes by more than 100 ns for the different energies, the 'jump' with the disconnected cables would not have been noticeable without filtering the data on energy.

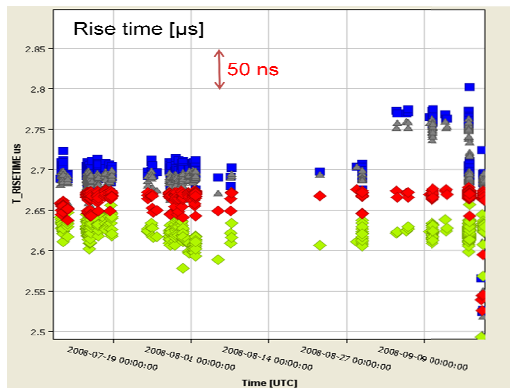

Figure 3: Measured dump kicker rise time at 450 GeV beam energy for four extraction kicker magnets, measured over several months.

Beam Instrumentation and Vacuum

The XPOC systems for beam instrumentation could not be fully commissioned because there were only few days of operation with beam.

The XPOC system was operational for the vacuum in the dump lines, including the overpressure of nitrogen of the dump block, and the beam loss monitors in the extraction straight and the beam dump line. No faults were detected, as expected due to the relatively large tolerance windows applied

One of the more interesting XPOC analyses is the image on the BTV screen in front of the beam dump block. Off-line analysis was made of several dumps. An interesting example is given in Fig. 4: the left image shows the BTV image of a beam which is not captured by the RF, de-bunched and over-injected by a second beam. The analysis process includes eight distinct steps with intermediate images, to finally produce a 'skeleton' of the image with a line width of one pixel. The right image shows in green the theoretical trajectory with a

determined acceptance (thickness of the trace) of a full beam sweep, in red the part of the resulting skeleton that coincides with the theoretical trajectory and in blue the part outside the acceptance.

Many beam dumps will be required during the 2009-2010 operational period to obtain references for the XPOC on the different beam instrumentation for nominal operating conditions, taking into account the different filling patterns, beam energy and beam intensity.

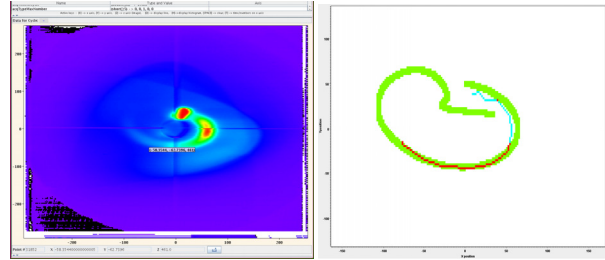

Figure 4: BTVDD image at the left and its XPOC analysis on the right.

CONCLUSIONS

The LHC beam dumping system operational checks, IPOC and XPOC, have been used to analyse thousands of kicker pulses before LHC operation with beam. They have shown their usefulness by detecting kicker system instabilities and changes to the system after interventions. Further modules of the XPOC system, mainly related to the beam instrumentation, remain to be further commissioned with beam in 2009. Some interesting off-line analysis with the XPOC system of beam images in front of the beam dump block show that the beams have been dumped according to expectations.

REFERENCES

- [1] The LHC Design Report: "The LHC Main Ring", Vol. 1, CERN, Geneva, 2004. <http://ab-div.web.cern.ch/ab-div/Publications/LHC-DesignReport.html>.
- [2] R. Filippini, "Dependability Analysis of a Safety Critical System: the LHC Beam Dumping System at CERN", CERN-THESIS-2006-054, Pisa Univ., 2006.
- [3] E. Carlier et al., "Design aspects related to the reliability of the control architecture of the LHC beam dump kicker systems", ICALEPCS 2003 – Gyeongju, Korea. <http://cdsweb.cern.ch/record/684957/>
- [4] E. Gallet et al., "Automatic post-operational checks for the LHC beam dump system", Proc. EPAC08, June 23-27 2008, Genoa, Italy.
- [5] J. Uythoven et al., "Results from the LHC beam dump reliability run", Proc. EPAC08, June 23-27 2008, Genoa, Italy.