

Ion beam techniques for nuclear waste management

Markus Schiffer^{1,*}, Alexander Stolz¹, Erik Strub², Susan Herb¹, Matthias Dewald³, Raphael Margreiter², Timm-Florian Papst¹, Kevin Geusen¹, Yannik Jakobi¹, Gereon Hackenberg¹, Claus Mueller-Gatermann¹, Stefan Heinze¹, and Alfred Dewald¹

¹Institute for Nuclear Physics, University of Cologne, Germany

²Division for Nuclear Chemistry, University of Cologne, Germany

³Gesellschaft für Anlagen- und Reaktorsicherheit gGmbH, Cologne, Germany

Abstract. An automated CO₂ gas handling and injection system was developed. It is designed to dilute CO₂ samples with blank gas in a mixing volume. The system is intended to be used for the characterization and quantification of ¹⁴C content in reactor graphite with accelerator mass spectrometry. A 100 kV accelerator system was developed to measure samples with high ¹⁴C content, to test the gas injection system and to measure the ³H content from gaseous releases of reactor graphite. Additionally, the Tandetron model 4130 was purchased from the Max-Planck Institute for Biogeochemistry Jena (Germany) and a concept was developed for installation at the accelerator building of the University of Cologne. With the new 3 MV system, new isotopic ratio measurements and ion beam techniques for material analysis can be performed. The system will be used for nuclear waste management measurements of isotopes, e.g. ³H, ¹⁴C, ³⁶Cl, ⁴¹Ca and ⁵⁵Fe, which are difficult to measure with other techniques.

1 Introduction

For the worldwide 250,000 tons of neutron-irradiated reactor graphite, currently no comprehensive disposal strategy exists [1]. The disposal of 1000 tons of neutron-irradiated reactor graphite represents an unsolved task in Germany. In contrast to other countries, this activated graphite does not come from breeding reactors, but originates from reflectors and thermal columns of research reactors or parts of fuel balls and other structures from the prototype reactors AVR (Arbeitsgemeinschaft Versuchsreaktor) in Jülich and the THTR-300 (Thorium High Temperature Reactor) in Hamm-Uentrop.

For the 500 tons from the reflector of the THTR-300, low levels of fission products and, due to the short operating time, only a relatively low neutron activation can be expected. Therefore possibly larger proportions of the material can be released for conventional disposal, if a suitable pre-treatment and a reliable characterisation is available.

The difficulty for the disposal of reactor graphite is the large amount of mobilisable activation products and the release of gaseous substances under repository conditions. This includes several long lived beta-emitters which are difficult to measure with common techniques like liquid scintillation counting, e.g. ³H, ¹⁴C and ³⁶Cl. The radioactive inventory is dominated by ¹⁴C, which is partly in the same chemical form as the matrix itself. Current pre-treatment approaches aim to reduce the ¹⁴C fraction, found in the pores of the reactor graphite by controlled heating.

This proportion comes mainly from the activation of the pore ¹⁴N and ¹⁷O. It is therefore in a different chemical form and can be depleted selectively [2].

The Cologne center for accelerator mass spectrometry [3], CologneAMS, has started an intense program for studying the applicability of accelerator mass spectrometry of nuclides like ³H, ¹⁴C, ³⁶Cl and ⁴¹Ca [4] in nuclear waste. It proposes a new precise and reliable way for the quantification of the radioactive material by the means of direct atom counting. CologneAMS currently uses a 6 MV AMS system from HVEE and a dedicated AMS beamline for medium mass isotopes at the 10 MV FN tandem accelerator [5]. The 6 MV AMS system was subsequently extended by a gas ion source and a gas handling system, dedicated for small ¹⁴C samples, e.g. in-situ produced cosmogenic nuclides [6]. Two new accelerator systems, with a terminal voltage of 100 kV and 3 MV respectively, will be built up, because reactor graphite material must not compromise the 6-MV AMS system which is used for our routine radiocarbon measurements.

2 The CO₂ gas handling system

For automated characterization and quantification of ¹⁴C content in reactor graphite with accelerator mass spectrometry, a new CO₂ gas handling and injection system for reliable industrial use was developed, funded by the FORKA C14-AMS project, funding number 1559410B. The system is designed to avoid background problems and complex sample preparation, related to the standard liquid

*e-mail: mschiffer@ikp.uni-koeln.de

scintillation counting (LSC) method, by the use of CO₂ gas injection to an accelerator mass spectrometer.

To convert the reactor graphite into CO₂ an elemental analyzer (EA) is used. This gas, with high ¹⁴C concentration, is then diluted with blank CO₂ gas in a mixing volume of the dedicated gas handling system, Fig. 1, and transferred to a gas ion source, where negative ions are produced. With the accelerator mass spectrometer the (¹⁴C/¹²C) isotopic ratios are determined. The total activity is then calculated from the total sample mass.

The new gas handling system was developed in house from the knowledge and longtime experience with the gas handling system of Ionplus for radiocarbon measurements [7] used in combination with the HVEE (High Voltage Engineering Europe) ion source [6]. The new system is designed for CO₂ gas measurements from different sources: either from an elemental analyzer (EA) or from a graphite pretreatment system for controlled heating. The CO₂ gas is guided with a He flow to a zeolite trap, where it is accumulated. By controlled zeolite trap heating, the CO₂ is released. It can be drawn in the gas-tight syringe, by a negative pressure when the syringe is driven to the backward position by a stepping motor. The system contains a mixing volume, which can be evacuated, filled from the syringe and from gases in storage reservoirs, e.g. standard and blank gas. The dilution of the sample with blank CO₂ can be performed likewise in the mixing volume and in the syringe. With the syringe, the sample gas can be passed under constant flow into the ion source. The entire process is controlled by the gas pressure, monitored with a single pressure sensor. In contrast to the Ionplus system, there are no bonded pipe connections, because only cutting ring fittings are used.

The graphite pretreatment system will be developed for controlled heating of reactor graphite samples with an inductive heating system in vacuum environment. The sample will be placed in a tungsten sample holder inside a quartz tube surrounded by the induction coil. The released gas is directed into the ion source via the gas system, where it can be diluted. In addition, the measurement of other beta-emitters like ³H and ³⁶Cl from the same gas-phase of the graphite will be developed. The verification of the new measurement technology will be proven by test graphite samples, irradiated with defined neutron flux and defined irradiation times at the TRIGA reactor Mainz.

3 The 100 kV Tandem Accelerator

A risk in the measurement of reactor graphite is the contamination of the AMS system. For this reason, a 100 kV accelerator system was developed to measure samples with high ¹⁴C content, that can be used to test the gas system until the mixing can be carried out reliably. This system is additionally dedicated for ³H measurements and extends the Cologne negative ion source test bench, Fig. 2. It consists of an ion source high voltage deck, for the use of a Middleton-Type or a NEC MC-SNICS ion source, and a double focusing 90° analyzing magnet, ρ=500 mm. The magnet is designed for high momentum resolution and high transmissions. The new 100 kV Tandem accelerator

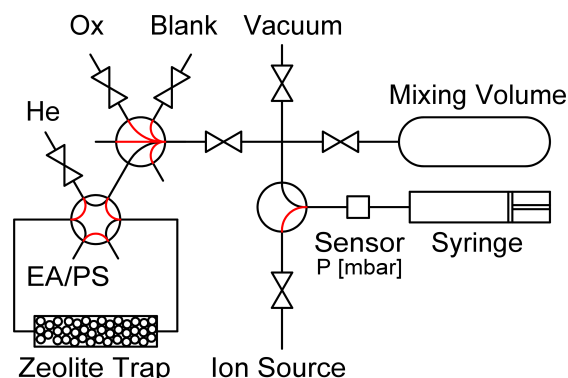

Figure 1. Dedicated gas mixing and injection system for the measurement of (¹⁴C/¹²C) isotopic ratios from neutron-irradiated reactor graphite. The system can measure CO₂ from an elemental analyzer (EA) or from the graphite pretreatment system (PS)

was designed with an 1 m acceleration tube and a carbon foil stripper. A special single stripper foil unit was developed with an easy to use foil changing tool. The high voltage will be generated by a commercial power supply. On the high energy side of the accelerator, a magnetic doublet quadrupole lens is used to focus the ion beam in front of the new installed high energy analysing magnet. This magnet was formerly operated at the Cologne 0.6 MV single ended accelerator and the magnetic field of 0.77 T is suitable to bend ³H⁺ with 350 keV ion energy. The bending radius of the magnet is 190 mm and the iron gap is 25.4 mm. With the vertical acceptance of the vacuum chamber (14 mm) a calculated transmission of approx. 80% can be reached. The vertical acceptance is limited because of the needed mechanical stability. A new vacuum chamber was designed for the use of offset Faraday cups in a standard ISO-160 double-cross. It is planned to use a silicon detector for the detection of the radionuclides downstream the analyzing magnet.

The whole setup will be controlled by programmable logic controller (PLC), Siemens S7 type. The LabVIEW based control software, used at the FN accelerator, is suitable for this setup with minor changes for the different setup components.

4 The 3 MV Tandem Accelerator

The Institute for Nuclear Physics of the University of Cologne has purchased the 3 MV Tandetrion model 4130 from the Max-Planck Institute for Biogeochemistry Jena (Germany), including the main components of the high energy mass spectrometer; the quadrupole doubled lens, the 110° analyzing magnet and the 33° electrostatic analyzer. The HVEE AMS system is dedicated for ¹⁴C measurements[8].

The installation of the new 3 MV AMS system at the Institute for Nuclear Physics of the University of Cologne will open up a wide range of applications like nuclear waste management measurements, as the FORKA C14-



Figure 2. The new 100 kV Tandem accelerator. Shown is (from right to left): the ion source, the double focusing 90° analyzing magnet, $\rho=500$ mm, the 1 m acceleration tube (without grounded protection housing), the quadrupole doublet and the 90° analyzing magnet, $\rho=190$ mm. Beam line components between accelerator and second magnet had not been installed.

AMS project for quantification of ^{14}C content in reactor graphite by use of the new gas handling system. The accelerator can be installed independently to the other accelerators with its own SF_6 gas system, Fig. 3.

Two main components of the 3 MV AMS system from Jena will be used for the new setup: the accelerator and the high energy mass spectrometer. The HVEE 3 MV Tandatron 4130 accelerator is furthermore used at the National Ocean Sciences AMS Facility at Woods Hole, Massachusetts (USA) [10] and the Leibniz-Laboratory for Radiometric Dating and Stable Isotope Research, Christian-Albrechts-University of Kiel (Germany) [11]. The accelerator is designed in a T-shaped geometry with a SF_6 isolated pressure tank. The system was designed for high current ion beams for implantations, activations and other ion beam techniques. A parallel-fed Cockcroft-Walton power supply, driven by 50 kHz, is used for the high voltage generation. The terminal voltage is stabilized by a generating volt meter or by slit feedback signals from the stable ^{13}C ion beam. The voltage ripple is reported to be lower than 40 V [12]. For the stripping process an Ar gas stripper is used with a circulation pumping unit and differential pumping units at each end of the stripper baffle [12]. Electrons and particles from charge changing processes or collisions with electrode surfaces are suppressed by the inclined electrostatic field structure of the acceleration tubes and by magnetic suppressors [10, 13]. On the high energy side, an electrostatic quadrupole doublet focuses the ion beam to the object slits in front of the double focusing 110° magnet. Two offset Faraday-cups for the measurement of ^{12}C and ^{13}C are mounted in the focal plane, as well as image slits for ME/q^2 selection. For E/q selection a 33° electrostatic analyzer is used to select a M/q value.

One possibility for the installation of the new 3 MV Tandatron accelerator is parallel to the SF_6 storage tank in the second basement of the accelerator building, see figure 3. This opens two opportunities: (i) to couple the

new injection system additionally to the 6 MV AMS System and (ii) to build up new beamlines for future applications in the neighboring hall, e.g. ion beam techniques for material analysis. An attractive arrangement of available components uses the 90° double focusing magnet from the new 100 kV accelerator and the 20° switching magnet of the Cologne duoplasmatron test bench. With this switching magnet different injection sources could be used: (a) one standard cesium sputtering ion source for solid and gaseous samples, (b) one duoplasmatron for He^- ions and (c) an ion beam cooler, for the development of chemical reaction suppression of isobars like ^{90}Zr for ^{90}Sr measurement and for photo laser detachment of $^{26}\text{MgO}^-$ for $^{26}\text{AlO}^-$ injection [14].

5 Conclusion and Outlook

Accelerator mass spectrometry provides a fast and reliable alternative for the determination of long lived beta-emitters which are difficult to measure with standard techniques like liquid scintillation counting. CologneAMS has started to build up dedicated infrastructures for nuclear waste management measurements.

An automated CO_2 gas handling and injection system for accelerator mass spectrometry was developed. It is designed to dilute the sample CO_2 with blank gas in a mixing volume. In the next project phase, different dilution series will be done with standard material, to show the measurement strategy of high ^{14}C concentrations. The proof of the setup will be performed after that, by measurement of test graphite samples irradiated with defined neutron fluences at the TRIGA reactor Mainz. Finally real graphite-reactor samples will be measured from different German graphite moderated nuclear-reactors.

An 100 kV accelerator system was developed to measure samples with high ^{14}C content. The system can be used to carry out tests of the gas handling system.

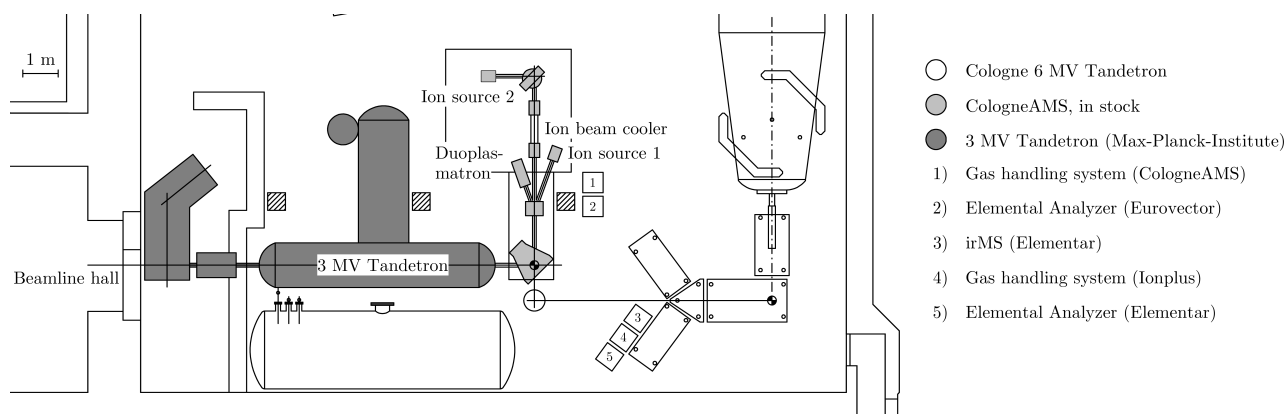

Figure 3. One possibility for the installation of the new 3 MV Tandatron accelerator in the second basement of the accelerator building of the Institute for Nuclear Physics of the University of Cologne. Shown are the new components from the MPI (dark gray) and the available components (light gray). Additional beamlines for future applications can be built up in the neighboring beamline hall.

The installation of a new 3 MV accelerator opens up two opportunities; nuclear waste management AMS measurements, e.g. ^{14}C , and ion beam techniques for material analysis.

5.1 Acknowledgement

We thank Dr. Axel Steinhof, from Max-Planck Institute for Biogeochemistry Jena (Germany), for his personal commitment to enable the purchase of the 3 MV accelerator. The project is partly funded by the BMBF (funding number 1559410B).

References

- [1] D. Vulpius, K. Baginski, B. Kraus *et al.*, Nucl. Eng. Des. **265**, 294–309 (2013).
- [2] W. von Lensa, D. Vulpius, H.-J. Steinmetz *et al.*, Atw. Internationale Zeitschrift fuer Kernenergie **57** 263-269 (2011).
- [3] A. Dewald, S. Heinze, C. Feuerstein *et al.*, EPJ Web Conf. **63** 03006 (2013).
- [4] R. Spanier, PhD thesis, University of Cologne (2019).
- [5] M. Schiffer, A. Stolz, D. Lopez *et al.*, Global and Planetary Change **184** 103053 (2020).
- [6] A. Stolz, A. Dewald, S. Heinze *et al.*, Nucl. Instrum. Methods B **439** 70-75 (2019).
- [7] M. Ruff, S. Fahrni, H. W. Gäggeler *et al.*, Radiocarbon **52** 1645-1656 (2010).
- [8] A. Steinhof, Nucl. Instrum. Methods B **331** 238-242 (2014).
- [9] J. R. Southon, D. E. Nelson, J. S. Vogel, Nucl. Instrum. Methods B **52** 370-374 (1990).
- [10] K. H. Purser, T. H. Stick, R. K. Purser, Nucl. Instrum. Methods B **52** 263-268 (1990).
- [11] M.-J. Nadeau, A. E. Litherland, A. Rieck *et al.*, Nucl. Instrum. Methods B **223-224** 346-352 (2004).
- [12] K. H. Purser, T. Smick, A. E. Litherland *et al.*, Nucl. Instrum. Methods B **35** 284-291 (1988).
- [13] K. H. Purser, Radiocarbon **34** 458-467 (1992).
- [14] M. Martschini, J. Pitters, T. Moreau *et al.*, Nucl. Instrum. Methods B **415** 9-17 (2017).