



EUROPEAN ORGANIZATION FOR NUCLEAR RESEARCH
ORGANISATION EUROPÉENNE POUR LA RECHERCHE NUCLÉAIRE

CERN - ST Division

ST-Note-2003-023

4 April 2003

**THE NEW 150 MVAR, 18 KV STATIC VAR COMPENSATOR FOR SPS:
BACKGROUND, DESIGN AND COMMISSIONING**

**K. Kahle, J. Pedersen / ST-EL
T. Larsson, M.M. de Oliveira / ABB**

Abstract

A new Static Var Compensator (SVC) was designed, installed and commissioned by ABB for CERN's Super Proton Synchrotron (SPS) accelerator. Due to the sensitive nature of the pulsating power converter load for the SPS magnets, very strict requirements were imposed on the stabilisation of the 18 kV bus voltage and its harmonic distortion. The adopted solution comprises a 150 Mvar TCR and eight harmonic filters with a total power of 130 Mvar. The paper gives a detailed description of the project background, system design and SVC installation. Finally, the results of the SVC performance tests are presented.

Presented at the 6th ST Workshop
Thoiry, France, April 1 – April 3, 2003

1 INTRODUCTION

For the power system, particle accelerators represent heavily pulsating electric loads with a variable power factor, mainly due to the used twelve-pulse and six-pulse thyristor power converters. Due to the large amplitudes and short rise times of the pulsating power, rapid reactive power control is necessary for voltage stabilisation and compensation of varying reactive power. In addition, strong filtering is required to eliminate the harmonics generated by the power converters. For this purpose, CERN is currently operating nine 18 kV Static Var Compensators with an installed total power of more than 500 Mvar.

The new Static Var Compensator was installed for the Super Proton Synchrotron (SPS) accelerator, which is a circular accelerator, 7 km in circumference. In the future, the SPS will serve as an injector of protons and heavy ions for CERN's new Large Hadron Collider (LHC), which is currently under construction.

The SPS accelerator is continuously pulsating with a cycle time of about 14 s. The load mainly consists of twelve-pulse thyristor power converters for bending and focusing magnets, RF cavities and LHC injection tunnels, with a total power swing from about zero to 230 MW and 200 Mvar within 2 seconds. The load is divided into two independent groups, and the power is supplied directly from the 400 kV European grid via two 90 MVA transformers EHT1 and EHT2, while EHT3 remains as a standby system, see Figure 1.

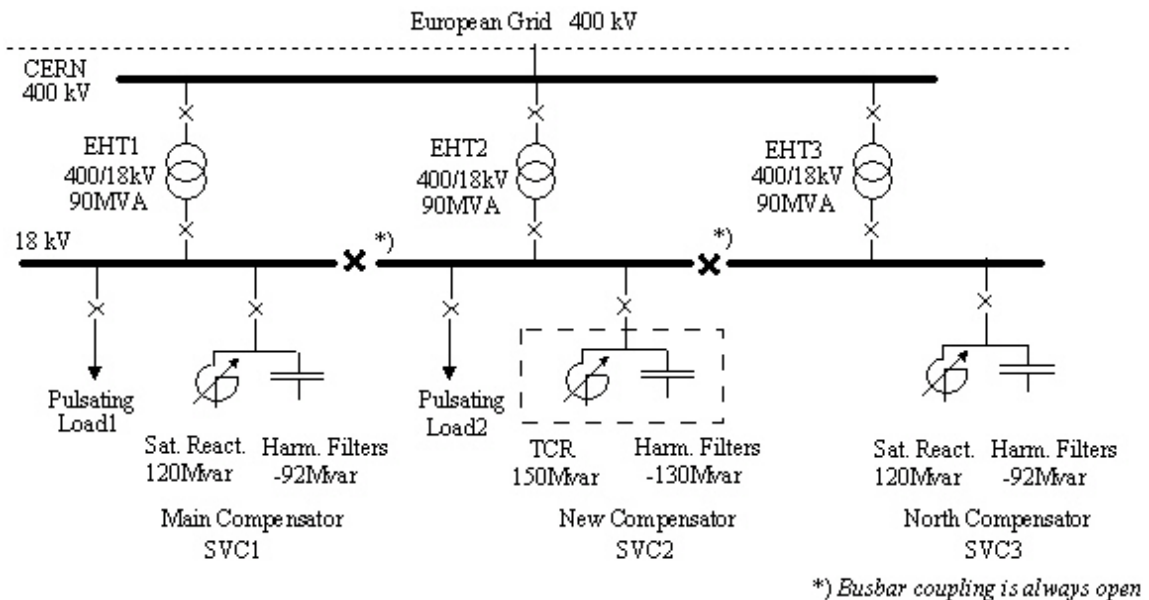

Figure 1: Simplified layout of the SPS power network

The compensation for the first load group is done by an existing 120 Mvar 18 kV SVC, based on saturated reactor technology. To cover increased power requirements and due to reliability issues, a new 150 Mvar 18 kV SVC was installed for the second load group. The third SVC, technically identical to the first one, is being kept as a standby system.

Following a call for tender among European companies, the contract for the design, supply and installation of the new SVC was awarded to ABB.

The present paper gives a description of the project background, system design and SVC installation. Finally, the results of the computer studies are compared to the SVC performance tests.

2 INITIAL COMPUTER STUDIES

In order to evaluate in depth the expected performance of the SVC and to investigate different technical variants, a consultancy contract for computer studies was agreed between CERN and the Royal Institute of Technology in Stockholm in the initial phase of the project. Figure 2 shows the network model used for these time domain computer studies.

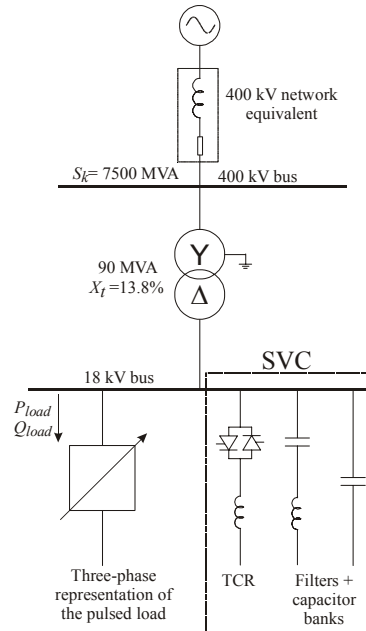

Figure 2: Network model used for the simulations

In the model, the load is represented as a combination of 15 % six- and 85 % twelve-pulse thyristor rectifiers. Based on previous measurements in the existing network and estimations of the future power requirements, a power pulse was defined and used in the simulations, as shown in Figure 3(a). Previous measurements also gave a base for the requirements on individual harmonic distortion of the 18 kV voltage as well as on Total Harmonic Distortion (THD).

The analysis of different technical variants led to a control system consisting of a conventional PI regulator for voltage control, and feed-forward paths for both active and reactive load power. The control system should also provide control of the tap-changer positions of the feeding 400/18 kV transformer to take into account long-term voltage deviations on the 400 kV grid. Figure 3 displays the results of the simulations.

For the given amplitude and slope of the power pulses the studies confirmed that the voltage variations at the 18 kV bus remain within a tolerance band of ± 0.5 %, see Figure 3(b).

Small variations of the 18 kV bus voltage were found at the transition points from the rising slope of the power pulse to the flat top and from the flat top to the pulse descent. During accelerator operation the particles such as protons or heavy ions are injected into the accelerator at the beginning of the power pulse. Acceleration takes place during the whole power pulse and the particles are gradually ejected during the flat top. At the end of the flat top, the acceleration cycle is finished and all particles have been ejected from the SPS. This also explains why the first voltage variation at $t=5.2$ s of the simulation is critical, while the second, larger variation at $t=6.1$ s has no major significance for the physics performance of the accelerator.

Without the SVC, the 18 kV bus bar of the SPS electrical network would suffer from periodic voltage variations of about 14 % during each power cycle. In this case the operation of the SPS accelerator would be impossible.

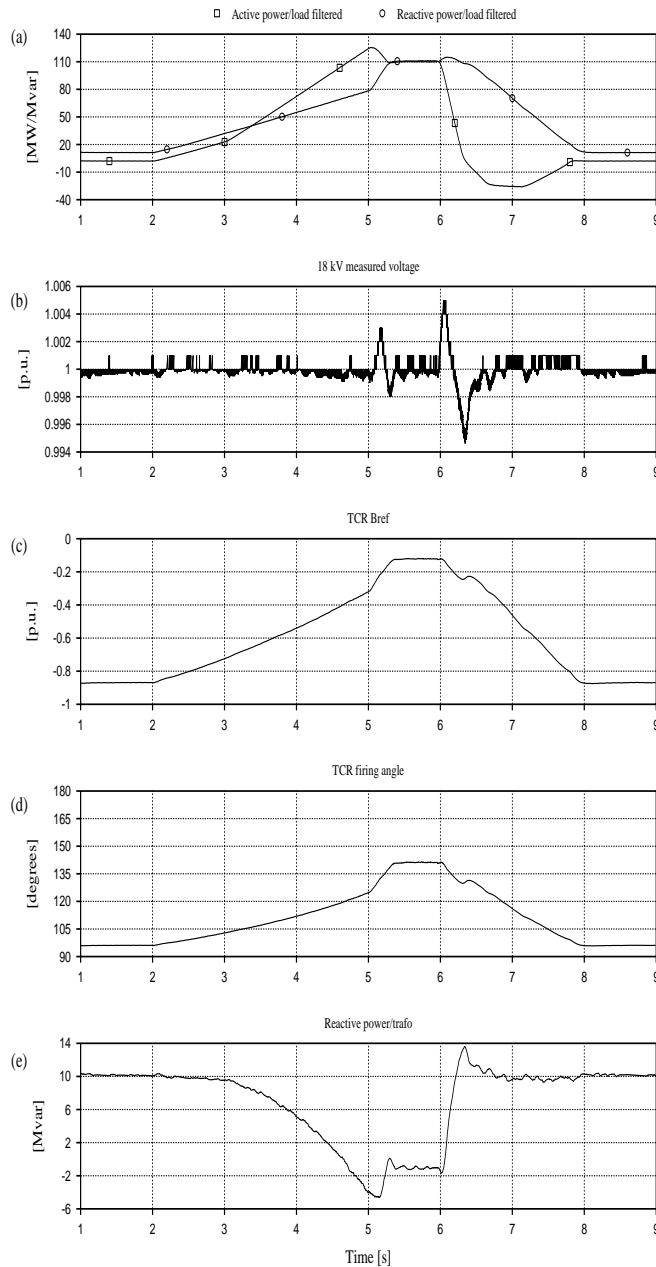

Figure 3: Results of the computer simulations:

- a) active and reactive power
- b) resulting 18 kV bus voltage
- c) TCR susceptance reference
- d) TCR firing angle
- e) reactive power drawn from the feeding 400 kV network

The second part of the studies analysed the expected harmonic performance of the SVC. For the harmonic studies, the design and rating of the harmonic filters of CERN's existing SVC1 were used, accommodating for some changes to take into account the increased power requirements of the filters and the harmonic spectrum generated by the TCR. These studies confirmed that eight harmonic filters were required in order to achieve a voltage THD below 0.8 %, with no individual harmonic exceeding the value of 0.4 %. Without an SVC, the 18 kV voltage THD would be around 20 %.

The results of the initial computer studies were used in the technical specification to quantify the required performance of the SVC.

3 SYSTEM DESIGN OF THE SVC

The SVC consists of a TCR rated at 150 Mvar and eight harmonic filters tuned to 100, 150, 250, 350, 550, 650 Hz and two damped high-pass filters, as shown in Figure 4. The filters generate a total reactive power of 130 Mvar.

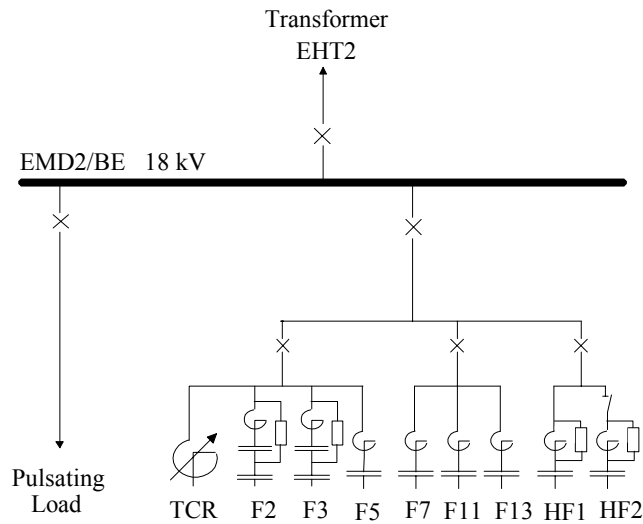

Figure 4: Simplified single line diagram of the new SVC

The filters F5, F7, F11 and F13 are standard LC filters while filters F2 and F3 are designed as C-type filters in order to minimize losses. These filters are applied to avoid instabilities due to the parallel resonance of the filter capacitors with the power system. Due to the increase in capacitive power of the new SVC2, compared to the existing compensators SVC1 and SVC3, the natural resonance point is at a lower frequency and close to the second harmonic. This aspect requires particular attention when designing the second harmonic filter in order to achieve the best compromise between a moderate filter impedance and sufficient damping. The dynamics of the SVC control, including measurement filters, was also designed to take into account this low frequency resonance.

The SVC will normally operate with all harmonic filters connected. To reduce SVC losses during periods of moderate network loading, the HF filter is split into two portions HF1 and HF2, allowing the disconnection of 18.2 Mvar of the filter HF2. The ratings of the individual filter branches are listed in Table 1, while Figure 5 shows the resulting impedance curve of the SVC with all filters in service.

Filter	Tuning	Type	Damping	Rated power [Mvar]
F2	2.0	C	3.8	13.6
F3	3.0	C	4.45	13.6
F5	5.0	LC	80	18.9
F7	6.95	LC	80	14.7
F11	10.95	LC	80	18.3
F13	12.95	LC	80	14.5
HF1	18.95	HP	9.8	18.2
HF2	20.95	HP	15	18.2

Table 1: Harmonic filter design characteristics

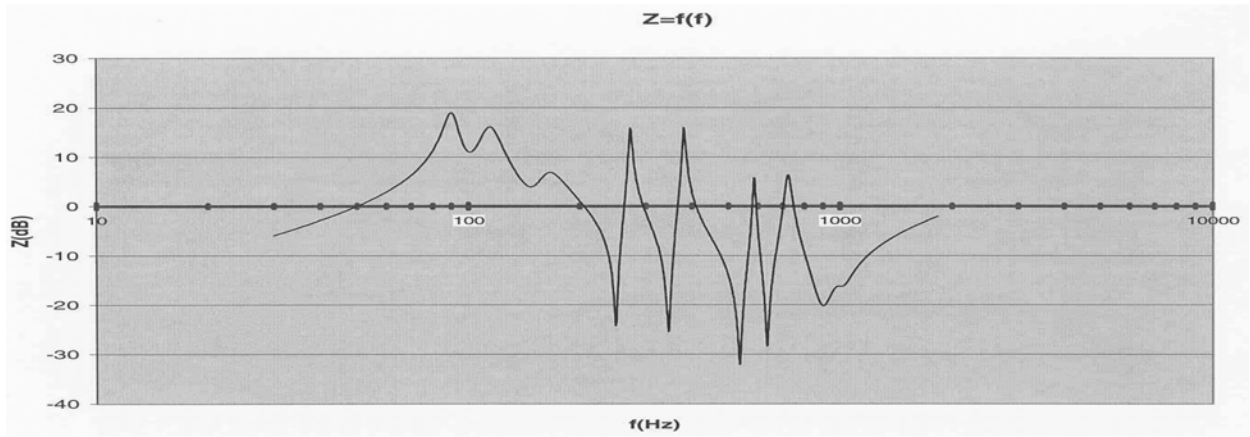

Figure 5: Impedance curve of the filter system

4 SVC INSTALLATION

The installation is located in Prévessin in France, close to CERN's major 400 kV station.



Figure 6: Photo of the SVC installation

The SVC is an outdoor installation covering an area of about 2500 m². It also includes a prefabricated building for the high voltage thyristor valves, the cooling system and the SVC control system. The SVC layout aims to minimise the time required for component maintenance and replacement. For this reason, the filter reactors and filter capacitors of the individual phases are arranged horizontally and not on top of each other. To reduce the number of faults introduced by wildlife and snow, large distances between live parts and earth were chosen, and the general insulation level was increased to 36 kV. The SVC layout was set up as shown in Figures 6 and 7.

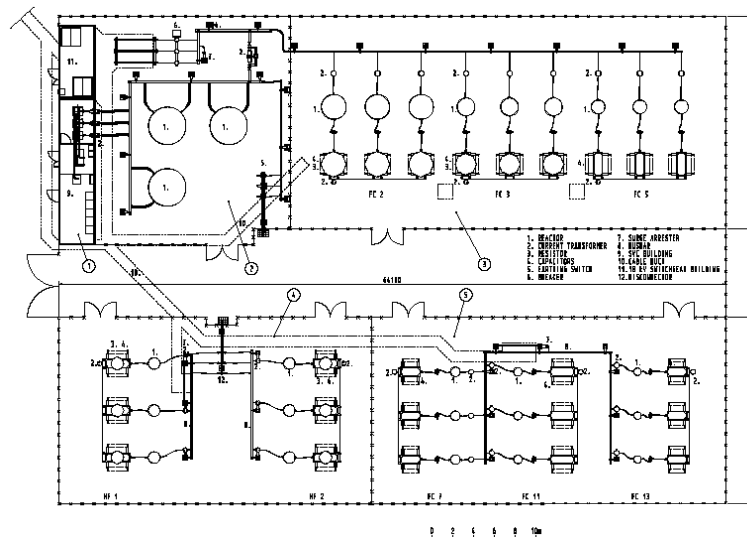

Figure 7: SVC layout

The prefabricated building with valve room, cooling room and control room is located at the top left. The three TCR reactor coils are installed behind the building, the remaining space is covered by the harmonic filters.

5 COMMISSIONING TEST RESULTS

As part of the commissioning, detailed performance tests and measurements were performed. As the future load of the SPS with the LHC Injection Tunnels will be different from the present operation scheme, the feeding 18 kV substation was configured to simulate the load pulse corresponding to the estimated load situation in 2006. During the performance tests, 18 kV bus voltage and load currents were recorded with a digital oscilloscope at a sampling frequency of 10 kHz. Data were then post-processed using MATLAB routines to calculate RMS values and harmonics.

Due to the pulsating load, as shown in Figure 8, the harmonic currents are also pulsating between almost zero and maximum. To find the worst case, five different time windows of the load pulse current were investigated:

- Low load, at t=0.8
- Pulse rise, at t=8.5 s
- Transition rise/flat top, at t=9.2
- Flat top, at t=9.6 s
- Descent, at t=10.6.

During times of low load (low load and pulse rise), the TCR is the major source of harmonic distortion. During periods of high load (transition rise/top and during flat top), the characteristic harmonics of the SPS twelve-pulse power converters dominate. Table 2 shows the maximum harmonic load currents measured during a load cycle.

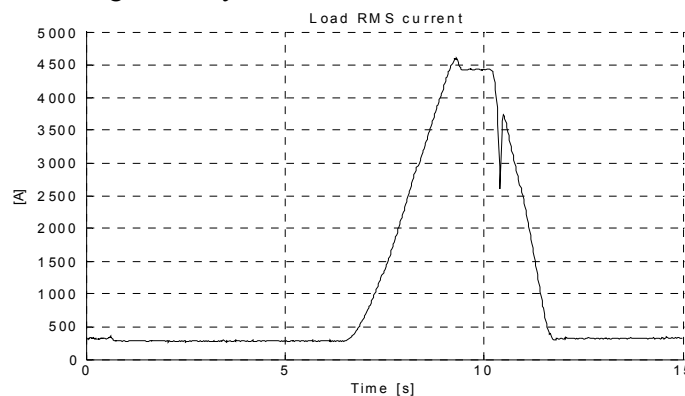

Figure 8: Measured load current during one SPS accelerator cycle

Harmonic order	Maximum measured load current harmonic [A]
2	47.8
3	29.7
5	21.9
7	20.4
11	460.7
13	275.4
17	13.1
19	12.5
23	83.4
25	87.6

Table 2: Measured maximum load current harmonics

Figure 9 shows the 18 kV phase-to-phase RMS voltage response during a load cycle with the SVC in operation.

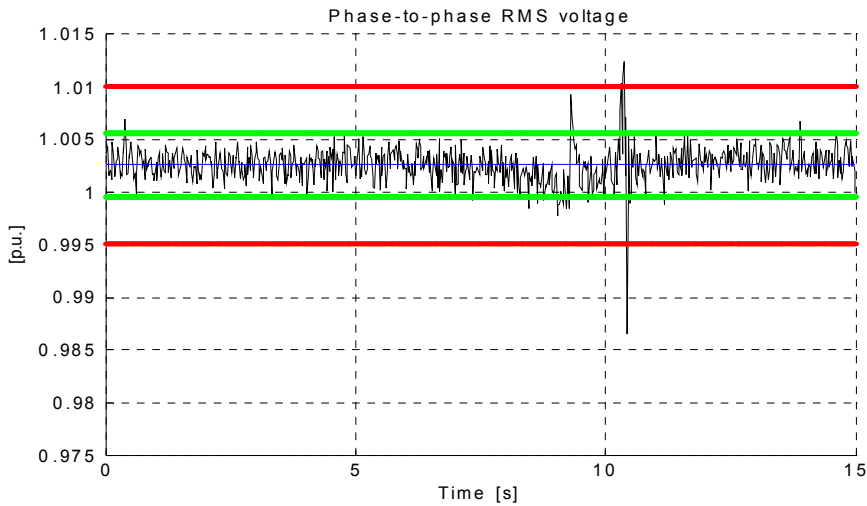

Figure 9: Measured 18 kV phase-to-phase voltage during SPS cycle

The RMS voltage was calculated with a 20 ms time window. The current in Figure 8 and the voltage in Figure 9 are synchronized in time. During the measurements the voltage shown in Figure 9 was slightly above the nominal value.

The horizontal lines in Figure 9 indicate the specified voltage variation limits of $\pm 0.3\%$ for slow and $\pm 0.75\%$ for fast load changes. During the acceleration of particles (pulse rise and flat top), the 18 kV RMS voltage remains within the limits of $\pm 0.75\%$. Due to the limited 8-bit resolution of the oscilloscope, truncation noise was introduced, seen as a ripple in the calculated RMS voltage of Figure 9. The inversion of the power converters at $t=10.6$ s causes a non-negligible phase shift of the 18 kV bus voltage, which makes it impossible to precisely quantify the amplitude of the spike of the RMS voltage occurring at this point of time.

The comparison of the simulated response in Figure 3(b) with the measured response in Figure 9 shows large similarities. All voltage notches, both up and down, are identical. Some discrepancies are found in the amplitude of the notches. Here the measured signals were significantly larger than the simulated figures, for the following reasons: The amplitude and gradient of the pulsating power was larger in reality than in the computer model, truncation noise of the measurement set-up introduced a degree of uncertainty and the method of data processing was different in both cases. Finally, the computer model may have to be improved to fully reflect the process. Still, the obtained RMS voltage response of the SVC proved fully acceptable for SPS accelerator operation and was therefore approved by CERN.

Harm. Order	Three-phase average harmonics levels [%]				
	Low load $t=0.8$ s	Pulse rise $t=8.5$ s	Trans. rise/top $t=9.2$ s	Flat top $t=9.6$ s	Descent $t=10.6$ s
(1)	(100.0)	(100.0)	(100.0)	(100.0)	(100.0)
2	0.07	0.09	0.21	0.12	0.14
3	0.27	0.26	0.09	0.13	0.06
5	0.25	0.31	0.18	0.27	0.18
7	0.17	0.18	0.16	0.17	0.17
11	0.10	0.32	0.50	0.29	0.36
13	0.10	0.11	0.28	0.46	0.25
17	0.10	0.09	0.07	0.12	0.11
19	0.07	0.10	0.11	0.10	0.07
23	0.06	0.07	0.10	0.22	0.26
25	0.05	0.06	0.11	0.23	0.11
THD	0.46	0.59	0.69	0.74	0.61

Table 3: 18 kV voltage harmonics calculated from measurements

Based on the recorded voltage response, the levels of harmonic voltage distortion were calculated for the different time windows of the load pulse, see Table 3. The maximum 18 kV THD observed during the load cycle was 0.74 %, while individual harmonics did not exceed the value of 0.5 %.

6 CONCLUSIONS

Following a long history of SVC projects at CERN since 1974, the new 150 Mvar 18 kV Static Var Compensator was successfully installed and tested in 2002.

During the project there was a unique opportunity to compare and verify comprehensive computer studies with the results of an extensive measurement campaign. Following the actual performance tests, the correct operation of the SVC, together with the SPS accelerator, was successfully proven over a period of several months.

This project also shows the excellent SVC performance, which can be achieved for fast changing rectifier loads, by using conventional TCR technology, combined with passive filtering.

7 ACKNOWLEDGEMENTS

The authors wish to express their appreciation to all colleagues who participated in the Static Var Compensator project. In particular we would like to thank D. Cerdan, D. Denuziere, Prof. Å. Ekström, S. Esbjörnsson, H. Hyvärinen, P. Laffin, K. Levrinus, J. Mullo, S.-O. Nilsson, J. Pajunen, H. Säfsström and S.-G. Wandin for their hard work, stimulating discussions and excellent co-operation.

8 REFERENCES

- [1] O. Bayard, June 1979, "The supply of the 148 MW pulsed power to the CERN SPS", *IEEE Transactions on Nuclear Science*, vol. NS-26, No.3.
- [2] J. Pedersen, D. J. Young et al., 1987, "Features of power electronics for thyristor controlled static reactive compensators for CERN – LEP", *Proceedings EPE Int. Committee*, Paris, France, vol. 3 (1318+72)