

EUROPEAN ORGANIZATION FOR NUCLEAR RESEARCH

CERN - AB Department

CERN-AB-2008-059

CLIC-Note -743

AN AUTOMATIC CONTROL SYSTEM FOR CONDITIONING 30 GHz ACCELERATING STRUCTURES

A. Dubrovskiy¹⁾, J. A. Rodriguez

CERN, Geneva, Switzerland

Abstract

A software application programme has been developed to allow fast and automatic high-gradient conditioning of accelerating structures at 30 GHz in CTF3. The specificity of the application is the ability to control the high-power electron beam which produces the 30 GHz RF power used to condition the accelerating structures. The programme permits operation round the clock with minimum manpower requirements. In this paper the fast control system, machine control system, logging system, graphical user control interface and logging data visualization are described. An outline of the conditioning control system itself and of the feedback controlling peak power and pulse length is given. The software allows different types of conditioning strategies to be programmed.

¹⁾ JINR, Dubna, Russia & CERN

Presented at
EPAC'08, 11th European Particle Accelerator Conference, Genoa, Italy - June 23-27, 2008

*Geneva, Switzerland
August 2008*

CERN-AB-2008-059
08 Sep 2008



AN AUTOMATIC CONTROL SYSTEM FOR CONDITIONING 30 GHz ACCELERATING STRUCTURES

Dubrovskiy Alexey*, (CERN, Geneva, Switzerland; JINR, Dubna, Russia)
Jose Alberto Rodriguez†, (CERN, Geneva, Switzerland)

Abstract

A software application programme has been developed to allow fast and automatic high-gradient conditioning of accelerating structures at 30 GHz in CTF3. The specificity of the application is the ability to control the high-power electron beam which produces the 30 GHz RF power used to condition the accelerating structures. The programme permits operation round the clock with minimum manpower requirements. In this paper the fast control system, machine control system, logging system, graphical user control interface and logging data visualization are described. An outline of the conditioning control system itself and of the feedback controlling peak power and pulse length is given. The software allows different types of conditioning strategies to be programmed.

INTRODUCTION

CTF3 is a test facility where the feasibility of the CLIC (Compact Linear Collider) must be demonstrated [1]. One of the key issues is to develop an accelerating structure which should work at an accelerating gradient above 100 MV/m, a pulse length of more 200 ns and a break down rate (BDR) less than 10^{-7} . The 30 GHz power production system was installed in CTF3 [2] in order to investigate properties of accelerating structures. Results obtained for different structure designs and structure power requirements are summarised in [3, 4].

The machine layout for the conditioning is shown in Fig.1. The linac generates a 3 GHz electron beam with an average current of up to 5A and a bunch length of 1 mm. Then 5 high power klystrons accelerate the beam, before it passes through the PETS (power extraction and transfer structure). Extracted 30 GHz RF is fed to the test-stand through a 30 GHz low loss waveguide. A variable splitter is used to direct part of the RF power to the accelerating structure and the other to a dummy load. The RF splitter allows a variable power with constant beam conditions. An accelerating structure is placed in the accelerating structure tank. Hardware and software interlocks, such as high vacuum levels, klystron trips, gun instability etc., have to be continuously monitored and permanently controlled. In case of a critical situation for a part of machine, the gun is automatically turned off. It is only possible to turn it back on when everything has been restored back to normal.

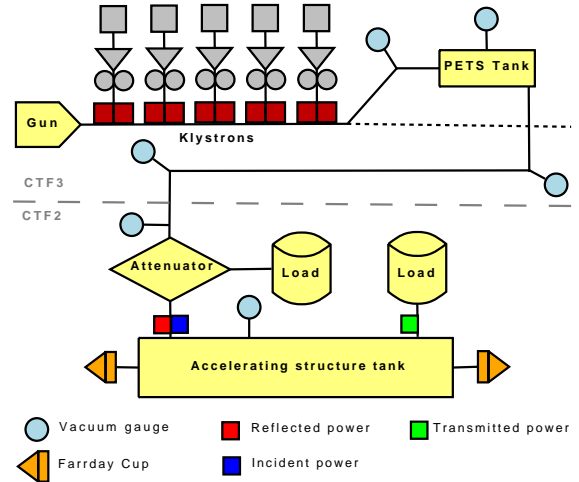

Figure 1: The machine layout.

CONDITIONING SYSTEM

A few words about conditioning processes of a system in general. The initial step is to define an appropriate list of conditions on the system. If over some period the experiment satisfies the requirements, one can analyse acquired data and draw a conclusion about characteristics of the system. Acquisition, control, feed-back and feed-forward systems help to adjust the experiment in accordance with the conditions (Fig. 2). Conditions themselves are defined by experts. The control parts and conditions of the structure conditioning are described below.

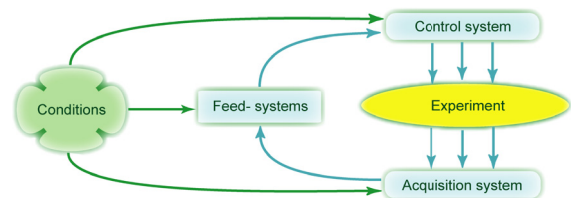

Figure 2: The conditioning system.

The acquisition system of the 30 GHz conditioning consists of the incident, the transmitted and the reflected RF power waveforms, a faraday-cup and a BPM signal, vacuum levels and machine interlocks (Fig. 1). The power profiles are presented as I/Q signals [5]. The power signals and faraday-cup signal are acquired pulse-to-pulse at a repetition rate up to 15 Hz and at a 1 GHz sampling rate. Calculations of the acquisition peak power and the pulse length are done using the incident power waveform.

The control system consists of the gun pulse length con-

* Alexey.Dubrovskiy@cern.ch, alex@solf.ru

† on leave, Jose.Alberto.Rodriguez@gmail.com

trol, switching on and off the gun, resetting interlocks and the attenuation control. The gun pulse length control changes the pulse length of incoming RF into a structure. And the attenuator allows to control the incident power as described in the introduction.

The computer architecture is shown in Fig. 3. The conditioning controlling server is responsible for all control operation and all acquisition calculations which are related to the conditioning process. Also two fast channel ADCs were installed on a compact PC containing eight channels in total. Configuration and control of the scopes and the channels are served by OASIS software [6]. Communications between device servers are provided by the software communication infrastructure for the controls Middleware CMW/RDA [7]. The automatic conditioning software was written by using FESA framework [8].

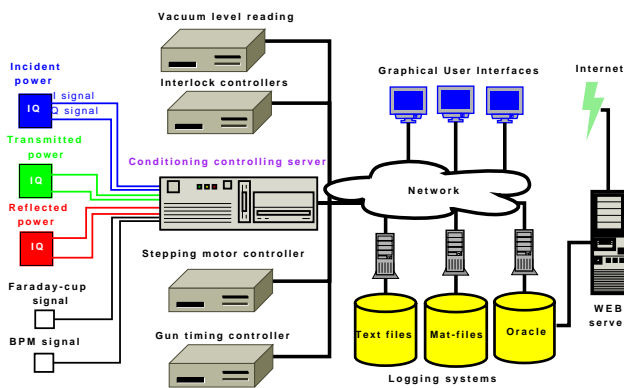

Figure 3: The computer architecture.

CONDITIONING ALGORITHM

A range of various structure conditioning procedures were investigated before the automatisatation was started. The conditioning software is an expert control application, which has been taking shape iteratively improving details based on the results of the tests themselves. The present conditioning logic (Fig. 4) consists of conditions on the three following types:

1. Safe machine operation, which is determined by machine interlocks.
2. Incoming RF properties: conditioning strategy and conditioning interlocks.
3. Experiment description: events and pulse summary logging.

The machine interlocks serve to detect abnormal behaviour in the machine and based on them, switch the machine into a safe mode. For the 30 GHz conditioning there are several crucial interlocks:

- *Gun inhibit interlock* is an indicator for the e^- gun that it is allowed to produce bunches. This interlock is dependent on the status of the gun, klystrons, RF components, personal safety components etc.

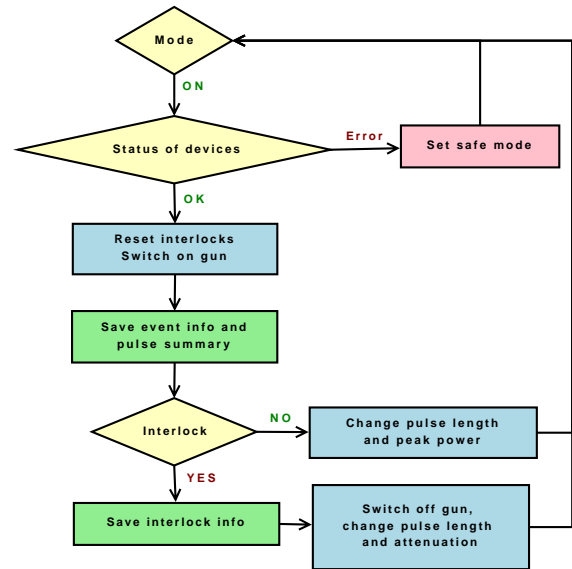

Figure 4: The conditioning logic

- *Vacuum interlocks*. In the RF path there are 5 relevant vacuum gauges: the pets tank, the first bend, the second bend, the third bend and the accelerating structure tank gauges (Fig. 1). They are all monitored to ensure that the conditioning operates at a low vacuum level.

The 30 GHz conditioning interlocks indicate an unexpected behaviour of a tested structure or a breakdown.

- *FC interlock* - the faraday-cup interlock is activated if the peak of faraday-cup signal exceeds a certain threshold. It's the most used indicator of breakdown.
- *Reflected energy interlock* is activated if the peak of reflected accelerating structure energy is above a certain threshold. This threshold is a percentage of the incident power.
- *Missing energy interlock* was implemented to measure the power absorption by accelerating structures. Missing energy is the incident energy minus the transmitted and reflected energy.

When an interlock is activated, the gun is switched off and the conditioning program reduces the pulse length and the peak power. After that the program waits for a predefined time in order to gather all interlock information and allow the structure time to recover. And then it switches the gun on.

The conditioning strategy is specified by specialists in order to raise the gradient in the structure without damaging it. All these procedures can be describe in the following way. An operator defines a target map consisting of pairs of pulse length and peak power points. According to that map, the program attempts to sequentially reach each target. The target is reached if the current gun pulse length and attenuator position exceeds the target values. At first the program increases the peak power, after which it increases the pulse

length. The time and number of steps to move from one target to another are specified. Due to the machine instability, the peak power and the pulse length vary slowly. A stabilisation feedback based on an exponential moving average and on fuzzy discrete control was implemented. It turns on if the conditioning reaches the last target or if the peak power or the pulse length exceed the feedback stabilisation target.

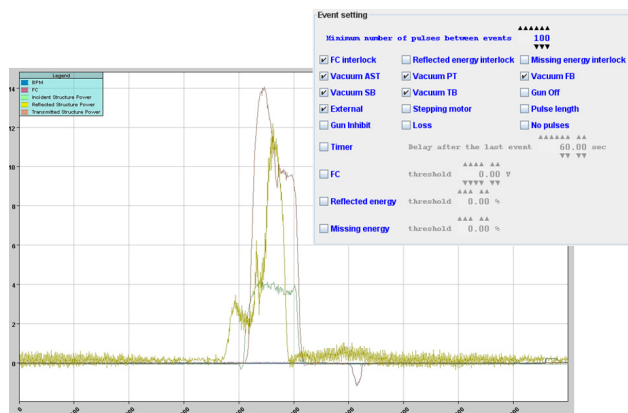

Figure 5: Pulse shapes of an event and events configuration.

The experiment logging consists of 3 parts: pulse summary, events and settings. For every pulse the program computes cardinal characteristics. For power signals they are the peak power, the energy and the pulse length. For the BPM and faraday-cup signals they are the total charge and the peak of the current. Also the missing energy, the reflected energy, the accelerating gradient and the breakdown indicator are stored. In case of an event the software stores all power and signal waveforms, vacuum levels, interlocks, the attenuator position and the gun pulse length for the last pulse and the two precedent pulses (Fig. 5).

CONDITIONING SOFTWARE

A fast control system, a GUI (Graphical User Interface), a logging system and a web-site were developed and evolved into a complex software system (Fig. 6). The fast control system is entrusted with the fast, stable and long-term conditioning process and with publishing data equipped with a time stamp. The logging system stores data in flat MAT- and TXT- files on local hard disks. Files

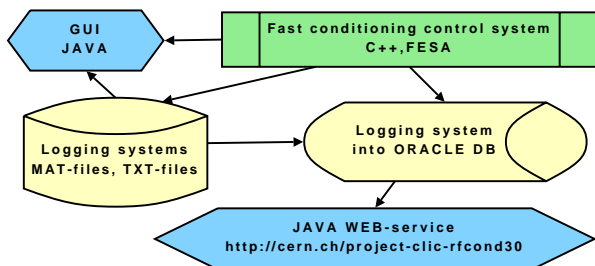

Figure 6: 30 GHz conditioning software infrastructure

are synchronised with a conditioning data depository. The GUI provides configuration visual forms, acquisition data displays, logging histograms and an alert-system (Fig. 7). The latter detects problems during operation and informs an operator. The GUI application was written in JAVA using JAPC, jdataviewer and other CERN java components [9]. The report-logging system sends summarised data over some period into the ORACLE data base. The web-service publishes web-pages about the current conditioning status and main characteristics, logging for the last tree days and history for all experiments [10].

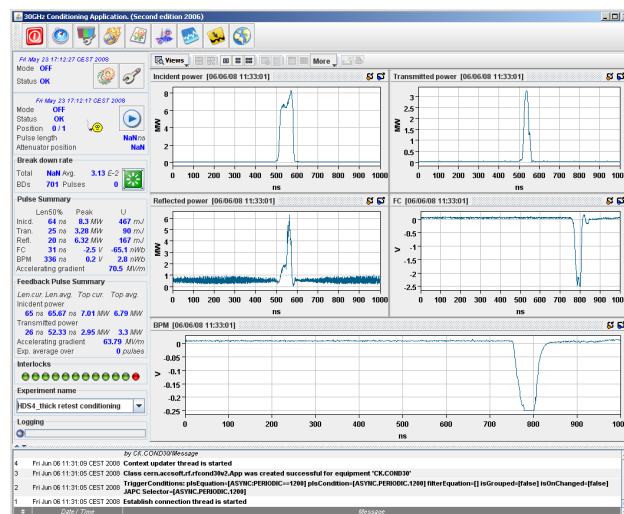

Figure 7: GUI screen shot of an acquisition panel.

REFERENCES

- [1] CERN. *The Compact Linear Collider Study*. <http://cern.ch/CLIC-Study>.
- [2] C. Achard, H. H. Braun, G. Carron, R. Corsini, A. Grudiev, S. Heikkinen, D. Schulte, J. Sladen, I. Syrathev, F. Tecker, I. Wilson, and W. Wuensch. 30 ghz power production in ctf3. 2005. Particle Accelerator Conference, Knoxville, Tennessee.
- [3] W. Wuensch, C. Achard, S. Doebert, H. H. Braun, I. Syrathev, M. Taborelli, and I. Wilson. A demonstration of high-gradient acceleration. 2003. Particle Accelerator Conference.
- [4] Jose Alberto Rodriguez. 30 ghz high-gradient accelerating structure test results. PAC, 2007.
- [5] Raquel Fandos. Rf acquisition system for clic high gradient testing. In *HG2006*, <http://indico.cern.ch>, September 2006. CERN, INDICO.
- [6] CERN/AB-CO. *OASIS*. <http://cern.ch/project-oasis>.
- [7] CERN/AB-CO-IN. *CMW*. <http://cern.ch/CMW>.
- [8] CERN/AB-CO-FC. *FESA*. <http://cern.ch/project-fesa>.
- [9] CERN/AB-CO-AP. *AB/CO/AP software development page*. <http://cern.ch/ab-dep-co-ap>.
- [10] CERN/AB-RF. *30 GHz conditioning home page*. <http://cern.ch/project-clic-rfcond30>.