

EUROPEAN ORGANIZATION FOR NUCLEAR RESEARCH
European Laboratory for Particle Physics*Large Hadron Collider Project***LHC Project Report 1140****PERFORMANCE OF THE MAIN DIPOLE MAGNET CIRCUITS
OF THE LHC DURING COMMISSIONING**

A. Verweij, V. Baggiolini, A. Ballarino, B. Bellesia, F. Bordry, A. Cantone, M. Casas Lino,
A. Castaneda Serra, C. Castillo Trello, N. Catalan Lasheras, Z. Charifoulline, G. Coelingh,
K. Dahlerup-Petersen, G. D'Angelo, R. Denz, S. Feher, R. Flora, M. Gruwe, V. Kain, B. Khomenko, G. Kirby,
A. MacPherson, A. Marqueta Barbero, K.-H. Mess, M. Modena, R. Mompo, V. Montabonnet, S. le Naour,
D. Nisbet, V. Parma, M. Pojer, L. Ponce, A. Raimondo, S. Redaelli, H. Reymond, D. Richter, G. de Rijk,
A. Rijllart, I. Romera Ramirez, R. Saban, S. Sanfilippo, R. Schmidt, A. Siemko, M. Solfaroli Camillocci,
Y. Thurel, H. Thiessen, W. Venturini Delsolaro, A. Vergara Fernandez, R. Wolf, M. Zerlauth

Abstract

During hardware commissioning of the Large Hadron Collider (LHC), 8 main dipole circuits are tested at 1.9 K and up to their nominal current. Each dipole circuit contains 154 magnets of 15 m length, and has a total stored energy of up to 1.3 GJ. All magnets are wound from Nb-Ti superconducting Rutherford cables, and contain heaters to quickly force the transition to the normal conducting state in case of a quench, and hence reduce the hot spot temperature. In this paper the performance of the first three of these circuits is presented, focussing on quench detection, heater performance, operation of the cold bypass diodes, and magnet-to-magnet quench propagation. The results as measured on the entire circuits will be compared to the test results obtained during the reception tests of the individual magnets.

LHC-PROJECT-REPORT-1140
20 Aug 2008

CERN, Geneva, Switzerland

Presented at the 11th European Particle Accelerator Conference (EPAC'08)
23-27 June 2008, Genoa, ItalyCERN
CH - 1211 Geneva 23
Switzerland

Geneva, 20 August 2008

PERFORMANCE OF THE MAIN DIPOLE MAGNET CIRCUITS OF THE LHC DURING COMMISSIONING

A. Verweij, V. Baggiolini, A. Ballarino, B. Bellesia, F. Bordry, A. Cantone, M. Casas Lino, A. Castaneda Serra, C. Castillo Trello, N. Catalan Lasheras, Z. Charifoulline, G. Coelingh, K. Dahlerup-Petersen, G. D'Angelo, R. Denz, S. Feher, R. Flora, M. Gruwe, V. Kain, B. Khomenko, G. Kirby, A. MacPherson, A. Marqueta Barbero, K.-H. Mess, M. Modena, R. Mompo, V. Montabonnet, S. le Naour, D. Nisbet, V. Parma, M. Pojer, L. Ponce, A. Raimondo, S. Redaelli, H. Reymond, D. Richter, G. de Rijk, A. Rijllart, I. Romera Ramirez, R. Saban, S. Sanfilippo, R. Schmidt, A. Siemko, M. Solfaroli Camillocci, Y. Thurel, H. Thiessen, W. Venturini Delsolaro, A. Vergara Fernandez, R. Wolf, M. Zerlauth, CERN, Geneva, Switzerland.

Abstract

During hardware commissioning of the Large Hadron Collider (LHC), 8 main dipole circuits are tested at 1.9 K and up to their nominal current. Each dipole circuit contains 154 magnets of 15 m length, and has a total stored energy of up to 1.3 GJ. All magnets are wound from Nb-Ti superconducting Rutherford cables, and contain heaters to quickly force the transition to the normal conducting state in case of a quench, and hence reduce the hot spot temperature. In this paper the performance of the first three of these circuits is presented, focussing on quench detection, heater performance, operation of the cold bypass diodes, and magnet-to-magnet quench propagation. The results as measured on the entire circuits will be compared to the test results obtained during the reception tests of the individual magnets.

INTRODUCTION

The LHC ring accommodates 1232 main superconducting twin-aperture dipole magnets, which are powered in eight independent and symmetric circuits, each containing 154 dipoles [1] and stretching over one octant of 3 km length. The 154 dipoles are housed in 27 cryogenic cells, and operate in a static bath of pressurised helium II, cooled by heat exchange with flowing saturated helium II. The cold part of each circuit contains as well four 13 kA gas cooled current leads incorporating stacks of Bi-2223 tape [2], and a large number of busbar cables, linking the dipoles together. Each circuit (see Fig. 1) is powered by a 13 kA power converter. The inductance of one circuit is 15.4 H and the total stored energy up to 1.1 GJ. Extremely reliable and fast quench detection and protection are therefore crucial. The protection of the dipoles is ensured by individual quench detection systems, cold by-pass diodes, quench heaters and two independent extraction systems [3, 4]. The functioning of these systems will be discussed elsewhere in this paper.

All dipole magnets have been assembled in industry by three different companies [5] and individually tested at CERN especially regarding field uniformity and quench behaviour [6]. After installation in the LHC tunnel, all electrical circuits are tested without beam during the so

called 'Hardware commissioning phase' [7] in order to ensure a safe and efficient machine start-up.

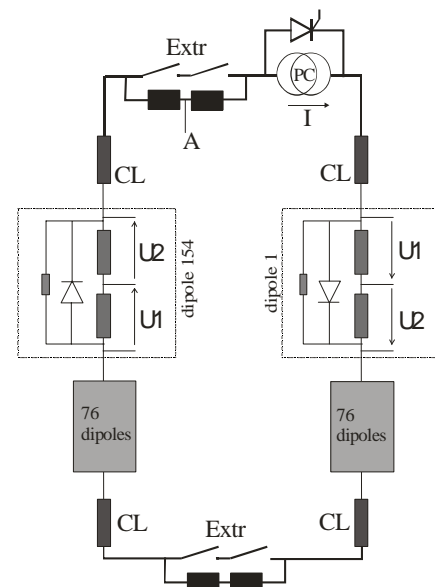

Figure 1: Schematic view of a dipole circuit of one octant of the LHC. Note that only the first and last dipoles of the circuit are shown in more detail. The system is grounded at point A by a circuit of resistances and a fuse. Each dipole is shunted by a 100 Ω damping resistance to reduce voltage oscillations after opening of the extraction switches. CL=Current Lead

GENERAL PERFORMANCE

Training

At present 2 out of 8 dipole circuits have been commissioned for a first target physics run of 5 TeV per beam, corresponding to a dipole field of 5.95 T and a dipole current of 8425 A. This field was reached without a single training quench. In both circuits the currents have been further increased until a first quench occurred at 9.8 kA (7.50 T) and 10.0 kA (7.68 T) respectively. Several more training quenches were then performed, reaching at present about 11.2 kA. Some important results from this training campaign are:

- Quenches at high currents cause adjacent magnets in the circuit to quench along, usually after 30 to 300 s, therefore with an important part of the energy already extracted. The maximum observed number of so-called secondary quenches in adjacent magnets was 5. The total energy dissipated in such a quench cascade never exceeded three times the stored energy of a single magnet.
- Several magnets show an unexpectedly low first quench level as compared to the reception tests that were performed in previous years. The exact origin is not yet known.
- None of the magnets showed more than one training quench between 10 and 11.2 kA.
- Some cases have been observed where two dipoles quenched at almost the same time, although the dipoles were spaced apart by more than 0.5 km.
- Some cases have been observed of highly symmetric secondary quenches, where both apertures of the dipole quench in an almost identical way, hence delaying the quench detection and increasing the hot spot of the coil.

Current Leads

The current leads showed no failures during the 1.9 kV insulation tests and all instrumentation in the leads performed as expected. The leads have been tested during many current cycles and plateaus, of which the longest took almost 10 hrs. No quenches of the HTS material have been observed. Under all operating conditions the voltage over the leads, and the temperatures at the cold and warm ends of the leads remain well within the required limits. The typical voltage drop over the resistive part of the lead is 38 mV at 8.5 kA, and the temperature at the top of the HTS elements is 50 K with a standard deviation of about 0.2 K. A detailed overview of the performance of the leads is presented in [8].

Current Regulation

Each dipole circuit is powered by a +13 kA, ± 190 V converter using 12-pulse thyristor technology, allowing the current to be ramped up and down in a controlled manner. The converter is equipped with an active filter that further reduces any 50 Hz components in the output current. As the LHC must operate 8 main dipole circuits over a single turn, an exceptionally high current regulation performance is demanded. Measurements from the first 3 sectors to be commissioned have shown that, over 3 months, an accuracy of 0.4 ppm (5.2 mA) is achieved. Over 30 minutes, this figure improves to 0.3 ppm (3.9 mA). Initial tests to demonstrate the tracking between multiple circuits have also provided excellent results. The performance is achieved thanks to highly precise DC Current Transducers, a 22-bit Sigma-Delta ADC and a robust RST algorithm for the current control [9, 10].

Extraction System

The extraction systems perform very well, with a typical switch opening time of 5 ms. The temperatures of

the dump resistances after extraction of a stored energy of 0.93 GJ, corresponding to a current of 11 kA, remain well below 200 °C as expected.

Superconducting Bus-bars

So far no natural quench occurred in any of the 13 kA bus-bars. There was no evidence of joints (between the bus-bars and the magnets, and between the bus-bars and the current leads) having a resistance significantly larger than the specified value of 0.35 n Ω , but due to their small resistances it was not possible to measure the exact values.

QUENCH EVENT

The protection of the dipoles relies on fast and reliable detection of resistive voltages which triggers the firing of heaters in the quenching magnet, and activates the extraction system causing a decay of the current in the entire circuit with a time constant of about 95 s. During this decay the current bypasses the quenched magnet by means of a cold diode. In this section the main actions during a quench event are discussed, from a quench event occurring at a current of 11119 A. In Fig. 2 the measured voltages are depicted during the first 140 ms after start of the resistive transition, originating in aperture 1.

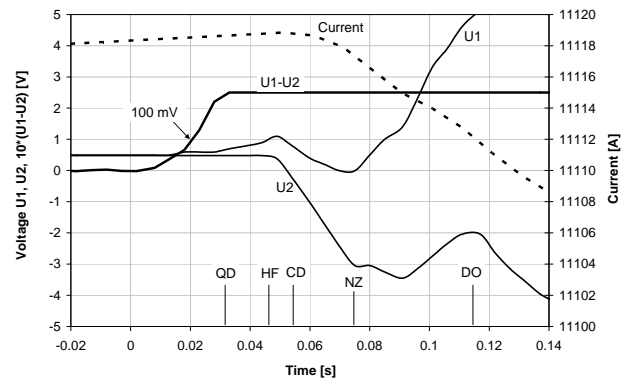

Figure 2: Voltage signals at the start of the quench. Note that the data acquisition time is 5 ms, the signal U1-U2 is limited at 250 mV, and the signals U1 and U2 are filtered values.

The quench detection is based on a floating bridge detector, which continuously compares the voltages U1 and U2 of the two apertures (of equal inductance of 50 mH) [3]. During the ramp both voltages equal 0.5 V. At the start of the quench the voltage rise is typically 4-10 V/s. Sometimes a kink in the slope is observed, indicating the start of one or more additional normal zones, probably due to inter-turn heat transfer. As soon as the differential voltage U1-U2 reaches the threshold voltage of 100 mV for longer than 10 ms, the quench detection is activated (see symbol QD in the figure) triggering within a few ms a discharge of the heater power supplies of the quenching magnet (HF). At the same time the detector triggers the opening of the two extraction

systems, and switches off the power converter. A bypass thyristor across the converter terminal ensures the circuit continuity after this action. Incorporating the extraction resistances in the circuit causes the current to decay (CD). The start of the ramp down is clearly visible by a change in the slope of the voltages U1 and U2 due to the presence of the additional inductive component. About 25 ms later the heat developed in the quench heaters causes the transition to the normal state of a large part of the cable, resulting in another change in the slope of U1 and U2 (NZ). As soon as the voltage over the entire magnet (i.e. U1+U2) reaches the diode turn-on voltage of about 6 V, the diode starts to conduct, and the current in the quenching magnet commutes into the diode (DO). No additional Joule heating is therefore generated in the quenched magnet while the circuit current is slowly reduced to 0 A. While conducting the current, the diode warms up quickly, causing the knee voltage to drop to a few volt. Due to possible asymmetry in quench propagation and resistance build-up between the two apertures there can be an imbalance in the resistive voltages between the two apertures. The maximum imbalance $|U1-U2|$ that has been observed during any of the quenches has been about 150 V.

QUENCH PROPAGATION

During the decay of the current, heat flow from the quenching magnet to the rest of the cryogenic cell usually leads to secondary quenches of neighbouring magnets located in the same cell. As an example the temperatures of the quenching magnet, and its next two neighbours (referred to as magnet 2 and 3) are depicted in Fig. 3 for the quench event described in the previous section. Note that the temperatures are measured by a sensor placed on the outer shell of the magnet, and therefore do not represent the actual temperature of the coil itself, neither the longitudinal variation of the temperature along the magnet. The heat dissipated in the quenching magnet warms up the helium in and around the magnet (in this case to 25 K maximum).

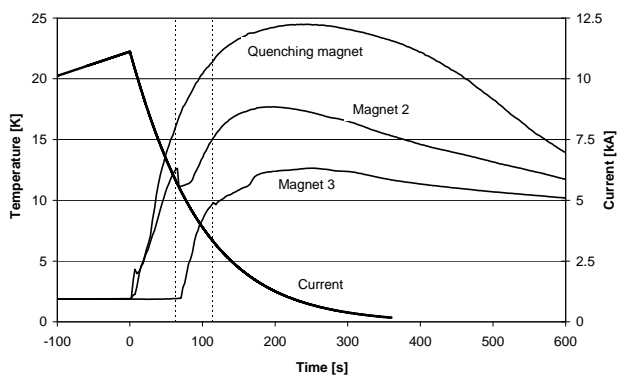

Figure 3: Temperature profile of the quenching magnet and temperature propagation to adjacent magnets. The two dotted lines show the times at which magnets 2 and 3 quench.

The heat propagates to magnet 2 which quenches after 63 s at a current of 5.8 kA and a measured temperature of 12.5 K. Magnet 3 quenches after 113 s at a current of 3.35 kA and a temperature of 9.7 K. These temperatures are higher than the current sharing temperatures at these currents and fields (6.8 K and 7.9 K respectively), showing that the helium in-between the beam pipe and the coil is significantly colder than the helium around the shrinking cylinder. During the quench event the pressure rise, due to the increase in helium temperature, is limited to about 18 bar by means of a relief valve.

CONCLUSION

Hardware commissioning of the dipole circuits in the first 3 sectors of the LHC has demonstrated that the LHC can be run at the first target beam energy of 5 TeV most likely without any dipole quench. Possibly a few training quenches are needed to run at 6 TeV. Reaching higher beam energies of up to 7 TeV will require a longer training campaign. The protection of the dipoles, which is ensured by individual quench detection systems, cold bypass diodes, quench heaters and two independent extraction systems, performs in an extremely reliable way. The current stability is better than 0.4 ppm. Also the HTS current leads and the superconducting bus-bars perform as expected.

REFERENCES

- [1] LHC design report, CERN-2004-003 (2004).
- [2] A. Ballarino, "HTS current leads for the LHC Magnet Powering System", *Physica C*, Vol. 372-376, pp. 1413-1418 (2002).
- [3] R. Denz, "Electronic Systems for the Protection of Superconducting Elements in the LHC", *IEEE Trans. on Appl. SC*, Vol. 16, no 2, pp. 1725-1728 (2006).
- [4] K. Dahlerup-Petersen et al., "Energy Extraction for the LHC superconducting circuits", *Proc. PAC 2001*, Vol. 5, pp.3448-3450 (2002).
- [5] F. Savary et al., "History of the series production of the LHC main dipole magnets", *MT20*, paper 4C01 (2007).
- [6] V. Chohan, "Testing of the LHC magnets in cryogenic conditions: operation challenges, status and outlook", *Proc. PAC 2005*, pp. 250-252 (2005).
- [7] R. Saban et al., "The Commissioning of the LHC Technical Systems", *Proc. PAC 2007*, pp. 3801-3803 (2007).
- [8] A. Ballarino et al., "Commissioning of the LHC Current Leads", *EPAC 2008*, paper 4090.
- [9] G. Fernqvist, "The measurement challenge of the LHC project", *IEEE Transactions of Instrumentation and Measurement*, Vol. 48, pp. 462-466 (1999).
- [10] F. Bordry, H. Thiesen, "RST Digital Algorithm for controlling the LHC magnet currents", *CERN/LHC Project report 258* (1998).