

## LHC INTERACTION REGION UPGRADE – PHASE-I

R. Ostojic, CERN, Geneva, Switzerland

### Abstract

The LHC is starting operation with beam in 2008. The primary goal of CERN and the LHC community is to ensure that the collider is operated efficiently, maximizing its physics reach, and to achieve the nominal performance in the shortest term. Since several years the community has been discussing the directions for upgrading the experiments, in particular ATLAS and CMS, the LHC machine and the CERN proton injector complex. A well substantiated and coherent scenario for the first phase of the upgrade, which is foreseen in 2013, is now approved by CERN Council. In this paper, we present the goals and the proposed conceptual solution for the Phase-I upgrade of the LHC interaction regions. This phase relies on the mature Nb-Ti superconducting magnet technology, with the target of increasing the luminosity by a factor of 2-3 with respect to the nominal luminosity of  $10^{34} \text{ cm}^{-2}\text{s}^{-1}$ , while maximising the use of the existing infrastructure.

### GOALS AND MILESTONES OF THE PHASE-I UPGRADE

The LHC, the largest and most complex endeavour in the history of high-energy physics, is ready for beam. By mid-2008, all of the machine sectors have been cooled down and the commissioning activities have almost been completed. The LHC construction effort has been considerable and has required important international participation. In parallel with its construction, the HEP and accelerator communities have been discussing possible routes towards increasing the reach of this unique scientific facility. The approach, given in the strategy document of CERN Council [1], is clear: to maximize the physics reach, any upgrade of the LHC in the first several years of running must comply with the operations schedule and the existing infrastructure. On the other hand, LHC relies on the injector chain and its reliability. These accelerators, in particular the venerable PS, must have priority in maintenance and upgrade. These boundary conditions have led to a phased approach to the upgrade of the LHC accelerator complex [2], which includes as the first phase the construction of a 160 MeV  $\text{H}^+$  proton linac (Linac4) and the upgrade of the LHC low- $\beta$  triplets.

The goal of the Phase-I upgrade of the LHC interaction regions is to enable focusing of the beams to a  $\beta^*$  of 0.25 m and to improve the reliability of operation at a luminosity of 2-3  $10^{34} \text{ cm}^{-2}\text{s}^{-1}$ . The upgrade concerns in the first place the low- $\beta$  triplets in the two high-luminosity experiments, ATLAS and CMS, assuming the same interfaces with the experiments as at present (located at 19 m on either side of the IP). The low- $\beta$  quadrupoles will feature a wider aperture than the present ones and will use the technology of Nb-Ti Rutherford-

type cables cooled at 1.9 K developed for the LHC dipoles. The D1 separation dipoles, as well as a number of other element in the beam line will also be modified so as to comply with a larger beam envelope associated with  $\beta^*$  of 0.25 m. However, the present cooling capacity of the cryogenic system and the other main infrastructure will remain unchanged, and will eventually limit the luminosity reach of the upgrade.

The LHC interaction region upgrade – Phase-I has been approved by CERN Council in Dec 2007. The elements of the upgrade have been discussed in a series of meetings and a conceptual design has been presented in July 2008. It is foreseen that the full technical design report will be completed by mid-2009. Later the same year, results from model magnet tests should be available. The production of the quadrupoles and other magnets is planned for 2010-2012. An important milestone is a string test in 2012 that should resolve any outstanding issue and minimize the commissioning time of the new magnets in the tunnel environment. The installation of the new triplets and other equipment is foreseen in a six-month shutdown in 2013, which coincides with the final stages of Linac4 commissioning and the first phase of ATLAS and CMS upgrades.

### UPGRADE CONSTRAINTS

The low- $\beta$  triplets presently installed in the LHC, shown in Fig. 1, were built by a collaboration of CERN, Fermilab, KEK and LBNL [3]. The quadrupoles have a coil aperture of 70 mm and use Nb-Ti superconductor cables that allow an operating gradient of 205 T/m. The 1.9 K cooling, electrical powering and all protection and control signals are fed to the triplet by an in-line feedbox, shown in the foreground of Fig. 1. The triplets are positioned at  $L^*=23$  m from the IP, and allow a  $\beta^*$  of 55 cm which corresponds to nominal LHC luminosity of  $10^{34} \text{ cm}^{-2}\text{s}^{-1}$ .

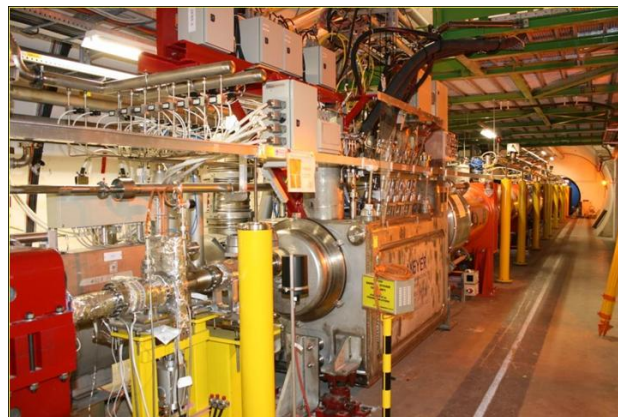

Figure 1: The low- $\beta$  triplet in the ATLAS insertion.

The most effective way of reducing  $\beta^*$  is to reduce the distance of the triplet to the interaction point (IP). The idea is not new and several attempts have been made already for the nominal LHC to arrange the different beam, vacuum and alignment equipment sitting in between the experimental area (19 m) and the triplet so as to reduce  $L^*$ . Unfortunately, this equipment is extremely densely packed and is located inside heavy shielding with limited access. In spite of detailed studies, no possibility has been found to bring the triplets forward while maintaining the agreed upon interfaces between the experiments and the LHC machine.

The cryogenic power is brought to the triplets in ATLAS and CMS insertions by the compound cryo-line (QRL) from the cryogenic islands located in the LHC even points [4]. Since they are at the extremity of QRL, the total cooling power available for the triplets will depend on the as-built heat loads in the adjacent arcs, which will be known better only after the first runs of the LHC with beam. In any case, the total power available for the triplets cannot exceed 500 W at 1.9 K, which is the maximum power the sub-cooler installed in the QRL can provide for the triplets. It should be noted that at present the cooling capacity available for the triplet in Sector 4-5 (left side of CMS) is smaller than for the others as the RF cavities in IR4 use about 4 kW of the total capacity of 23 kW at 4.5-20 K of the cryo-plant servicing this sector. It should also be noted that the sectorization of the QRL does not allow to warm-up the insertion magnets separately from the arcs. Hence, four LHC sectors have to be warmed-up to exchange the triplets in ATLAS and CMS insertions.

It is clear that any increase of cooling requirements, in particular those related to the increase of luminosity above  $2\text{-}3 \cdot 10^{34} \text{ cm}^{-2}\text{s}^{-1}$  will need dedicated cryogenic plants serving the inner triplets around ATLAS and CMS. Their installation will most likely require a certain level of civil engineering in the underground areas. These changes are best done at the time of the Phase-II upgrade when the two experiments will also perform their own extensive modifications.

As shown in Fig. 1, all major equipment of the triplets is located in the LHC tunnel, with the exception of the power converters which are housed in alcoves adjacent to the machine tunnel (in ATLAS), or parallel to the experimental cavern (in CMS). The alcoves are separated from the tunnel by shielding walls, through which water-cooled cables run linking the power converters to the triplet feedboxes. Access for maintenance of the equipment in the tunnel, in particular of the current leads, is difficult and may have consequences on the LHC operation. In view of the even higher radiation levels after the upgrade, it is necessary to remove all delicate equipment from the tunnel, including the feedboxes, and place it in low radiation areas. Such areas are very scarce around the ATLAS and CMS triplets, and it may be necessary to further shield the alcoves.

The access and transport of magnets to and from ATLAS and CMS implies long hauls over several

kilometres alongside the chain of cold magnets. Although care had been taken during LHC design to enable transport of magnets at any time, the LHC tunnel is tight and transport of equipment is a delicate operation. Preparing the triplets for transport therefore has to be carefully planned. In any case it is clear that all new equipment has to comply to the allowed transport envelope, which coincides with the length, mass and cross-section of the LHC main cryo-dipole.

It is well known from the optics and beam studies made during the LHC design that a reduction of  $\beta^*$  has a number of consequences on the performance of the machine. The chromatic aberrations, linear and of higher order, are particularly serious and must be carefully controlled and compensated. Of particular concern is the off-momentum beta-beating,  $\Delta\beta(\delta)/\beta(0)$ , which must be compensated in the triplets and in the betatron and momentum cleaning insertions (IR7 and IR3). It should be noted that a  $\Delta\beta(\delta)/\beta(0)$  larger than about 10% leads to mixing in the 6-D phase space that may corrupt the collimation system [5]. As chromatic aberrations concern the LHC as a whole, new optics solutions are required for the Phase-I upgrade goal of  $\beta^*=0.25 \text{ m}$  while using the existing corrector circuits to their maximum potential.

## THE PROPOSED CONCEPTUAL DESIGN

### *LHC optics*

As mentioned in the last section, the Phase-I upgrade requires a new optics solution for the LHC which minimizes chromatic aberrations. Such solutions, based on imposing a  $\pi/2$  betatron phase advance between IP1 and IP5, have been studied in the past for the nominal LHC, but without a fully satisfactory result. A new approach has been devised recently [6], which is based on using the sextupole families in the two sectors adjacent to each triplet to excite a  $\Delta\beta(\delta)$  wave that interferes in phase and cancels the wave generated by the triplet. The solution requires that the cell phase advance is very close to  $\pi/2$  and that a well defined phase relation exists between the IP and the arc. Under these circumstances it has been shown that the long-standing problem of  $\Delta\beta(\delta)/\beta(0)$  compensation can be resolved. Using the maximal current of the sextupole families, the off-momentum beta-beating can be reduced below 10% everywhere in the LHC for  $\beta^* \geq 0.25 \text{ m}$ . Furthermore, these phase conditions also enable compensation of the spurious dispersion in the ring, generated by the large crossing angle, proportional to  $1/\sqrt{\beta^*}$ . However, as these phase conditions have to be achieved in all the arcs and insertions, the integer tune of the LHC changes, and the tune split is reduced from 5 to 3. Further work is still necessary to fully validate the proposed solution at injection, possibly including machine studies in the LHC itself.

Besides the phase conditions imposed by the ring optics, the optics in the ATLAS and CMS insertions must be consistent with the parameters of the magnets in the

dispersion suppressors and matching sections (Q4-Q11) and of the other equipment, which will remain after the Phase-I upgrade. This concerns in particular the strength and aperture of the quadrupoles, and the aperture of the collimators and absorbers. Several possibilities were examined and it was found that as a general rule the shorter the focusing length of the new triplet the larger is the aperture margin in the matching sections, but the lower the flexibility of matching. On the other hand, by displacing Q4 and Q5 quadrupoles towards the arc by 10-15 m, the aperture and matching conditions for a given triplet can be improved. The longest Nb-Ti triplet that can be matched to the rest of the insertion is about 40 m long, and is given by the available strength and aperture of the dispersion suppressor quadrupoles.

On the basis of these studies it was concluded that the appropriate solution for the Phase-I triplet is a quadrupole with a coil aperture of 120 mm and an operating gradient of 120 T/m. It was also estimated that displacing the matching section to a new position has a considerable impact on a number of infrastructural elements (e.g. the QRL cryo-line and the DSL superconducting link), and that it would need to be done during the same shutdown as the replacement of the inner triplets. It was hence concluded that Phase-I upgrade should assume that the magnets of the matching sections remain as they stand.

### Triplet layout

The present LHC low- $\beta$  triplet, shown in Fig. 2, is of the symmetric type with the two outboard magnets, Q1 and Q3 with a magnetic length of 6.6 m, while the two inner magnets, Q2A and Q2B (housed in the same cryostat), have a length of 5.7 m. The interconnect lengths between Q1-Q2 and Q2-Q3 are slightly different. The

orbit and other correctors are distributed in all three quadrupoles. The separation dipole D1 is composed of six modules of normal conducting magnets.

The triplet for the Phase-I upgrade will necessarily be longer than the present one, as the operating gradient is about 40% lower (coil aperture is 70% larger). Nevertheless, the intention is to follow the symmetric layout as much as possible, as it offers a number of important advantages. A preliminary layout is also shown in Fig. 2, and features four identical magnets, each about 10 m long, and identical interconnects. There are clear advantages of having identical magnets for the timely and cost-effective production. For similar reasons, it is proposed to group the corrector magnets in a separate unit placed on the upstream side of the triplet. Finally, a superconducting D1 dipole replaces the present normal conducting magnets, such that the full length of the new triplet string is almost identical to the present one.

A number of issues still need to be resolved for the new triplet. For example, the preliminary studies have shown that for realistic alignment of the quadrupoles the orbit correction with a reduced set of orbit dipoles results in a comparable residual orbit error and favourable strength requirements. However, the control of the beam position at the IP requires further studies. The number and position of the BPMs also has to be defined, as well as the space necessary for linking the triplet to the cryo-line and the current buses. Also, a precise evaluation is needed of the gain obtained in case the two central quadrupoles Q2A and Q2B were to have a slightly different length, as in the present triplet. All these and other open questions will be resolved in the coming months as the technical design proceeds to completion (mid-2009).

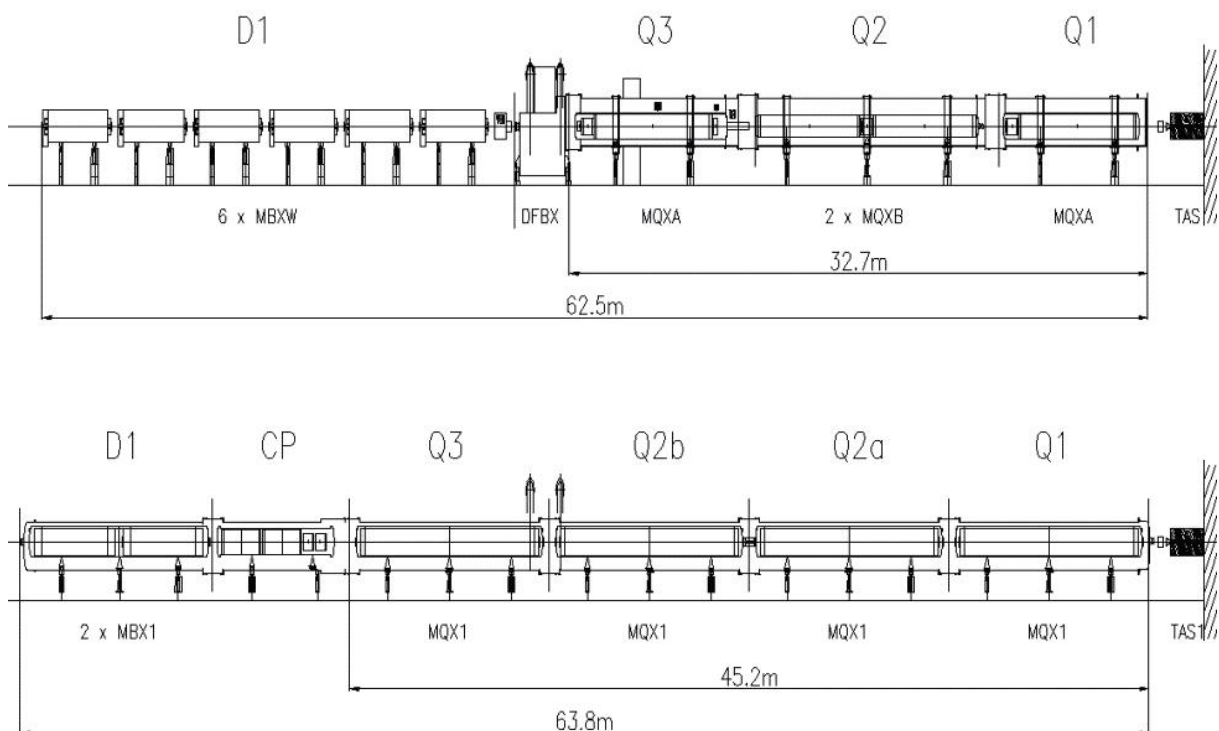

Figure 2: Layout of the present LHC triplet (top) and proposed layout of the Phase-I triplet (bottom).

*Powering and magnet protection*

The considerably larger stored energy in the new low- $\beta$  quadrupoles requires that the magnet protection be revisited. In the present design, the triplet magnets are protected by built-in quench heaters. When a quench signal is issued, the quench heaters in all magnets are activated irrespective of the source of the quench signal. As the powering circuit does not contain energy extraction resistors the full magnetic energy is dissipated in the cryogenic system. The temperature of the magnets and helium pressure after quench are therefore high, and the time to cool the triplet back to the nominal operating temperatures is comparatively long. Nevertheless, the system has proven to be fully operational and reliable.

The new low- $\beta$  quadrupoles will also be equipped with quench heaters. However, to improve the magnet protection, and at the same time reduce the cryogenic recovery time, the powering circuits for the Phase-I triplets will also include energy extraction. The presently preferred scheme, shown in Fig. 3, consists of two identical circuits, each covering two magnets (Q1-Q2A, Q3-Q2B). In addition to the main 12 kA power converter, a 2 kA trim is foreseen to allow for full optics flexibility. Quench detectors will be of the bridge type, similar to the present ones. Several possibilities were considered for the switches, extraction resistors and bypass protection. The final choice remains to be made, but the primary criteria

will be the radiation hardness and volume of the equipment.

The quench protection units, power converters and the feedboxes will be housed in shielded areas away from the machine tunnel. The feedboxes will be connected to the magnets with a cold link. Several types of superconducting links, carrying currents up to 6 kA and cooled with supercritical helium, already exist in the LHC. The new ones must carry 12 kA for the main quadrupole circuits, as well as lower currents for the correctors. They should preferably be based on He-gas cooling to avoid additional cryogenic distribution. New developments using MgB<sub>2</sub> wires are actively investigated.

*Protection from particle debris*

With ever higher luminosities the protection of magnets and other equipment from particles generated in the collisions is of crucial importance. The starting point is to ensure that the magnets can sustain steady-state heat loads generated by the particle debris with adequate margin with respect to the quench limit. This issue has been studied in considerable detail for the present triplets and the coil protection was steadily improved until a factor of three safety margin with respect to estimated quench limits was achieved [7].

As the power density from the debris scales with luminosity, it is clear that protection efficiency for a luminosity three times the nominal one must be higher

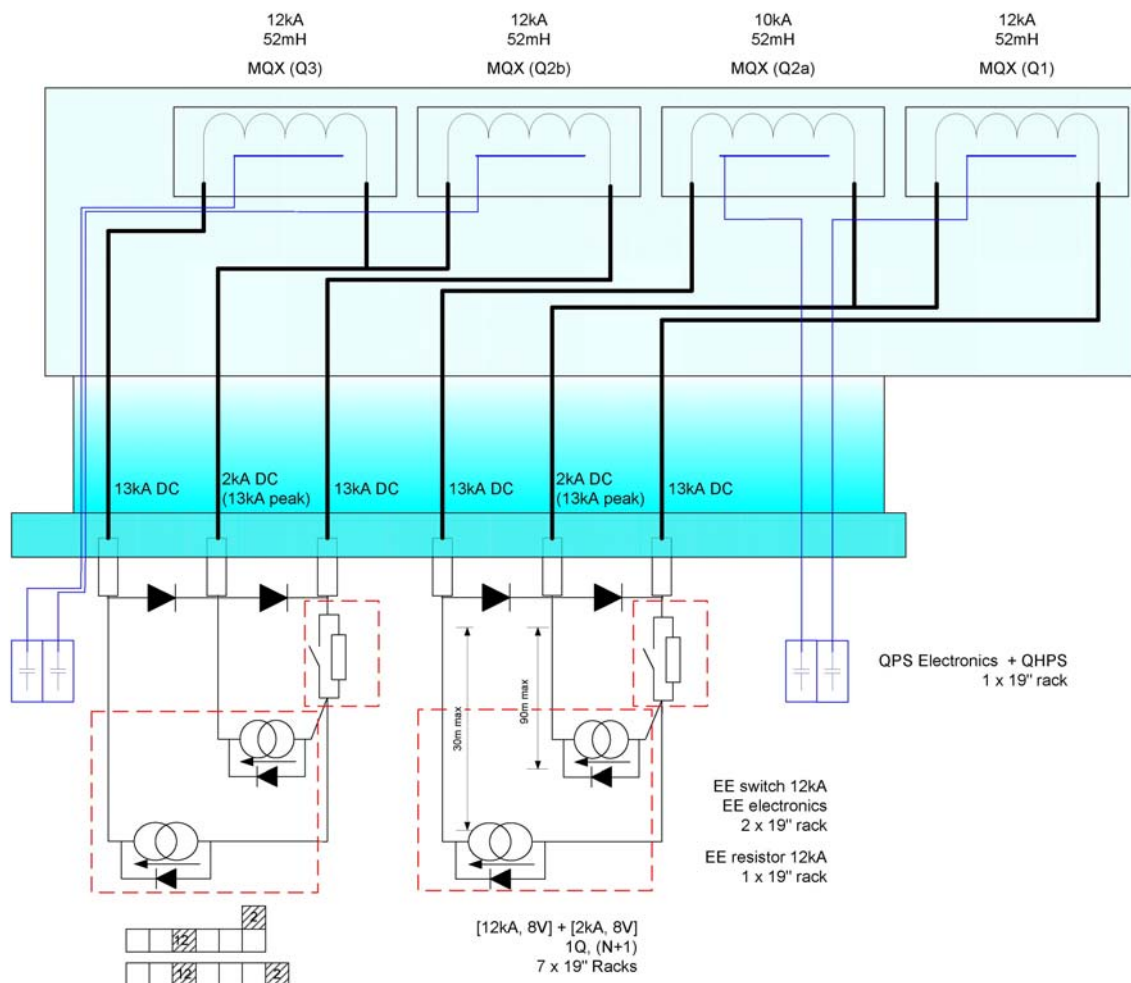

Figure 3: Proposed split-powering scheme for the Phase-I triplet.

than in the present triplet. It is assumed for the purposes of the conceptual design that the heat transfer properties of the new low- $\beta$  quadrupoles will be the same as in the present magnets, although work has started on improvements. The design limit for power density ( $4.3 \text{ mW/cm}^3$ ) is therefore assumed identical. Studies performed recently for several candidate layouts have shown that the increased aperture of the quadrupoles has a beneficial effect on the protection efficiency [8]. In fact, for a luminosity 2.5 times the nominal, it was shown that the peak power density is within the design limits for most of the magnets. It is only between Q1 and Q2 that the peak exceeds the limit. Fortunately, due to a reduced aperture requirement for Q1, additional shielding can be included as part of the beam screen assembly, effectively eliminating the peak. The additional heat load is evacuated by the beam screen (5-20 K), which needs to be taken into account for its design. Similar local solutions may also be needed in the interconnects between the magnets. Furthermore, all cases studied show that the estimated total heat load in the triplet magnets is about 400 W at 1.9 K, which is still compatible with the existing maximum cooling capacity.

Very important elements for magnet protection are the two absorbers, TAS and TAN, which already exist in the LHC. The function of these elements remains identical. However, due to the modified magnet apertures and increased luminosity changes are necessary in their design. The main function of the TAS, located between the experiment border (19 m) and the Q1 quadrupole, is to shield the triplet and reduce backscatter to the experiments. Its vacuum chamber is designed such to be as close as possible to the beam envelope. Since the beam size and excursion will increase due to lower  $\beta^*$ , the vacuum chamber of all four TAS in ATLAS and CMS must be replaced. The most effective way, in terms of access, handling and costs, is to build new TAS bodies and vacuum chambers. This is also an opportunity to introduce a cooling system, as the total heat load in the TAS body will be about 400 W.

The TAN is located 140 m from the IP. Its role is to protect all downstream equipment from the neutral particles at the point where the two beams transit from a common to separate vacuum chambers. The present TAN is perfectly adequate for the luminosity of  $10^{34} \text{ cm}^{-2}\text{s}^{-1}$  and  $\beta^*$  of 0.55m. However, for a luminosity 2.5 times higher the TAN will receive about 600 W. Furthermore, for a  $\beta^*$  approaching 0.25 m, the aperture of the present TAN may become the limiting element in the insertions. It is therefore quite probable that the TAN will have to be replaced.

The debris power in the magnets is also a generator of considerable radiation dose. In the present triplets, a peak dose of 3.5 MGy is expected in the coil for a standard annual run during which  $75 \text{ fb}^{-1}$  of luminosity are accumulated. In the new triplets the dose in the coil inner layer is estimated at about  $1 \text{ MGy}/100 \text{ fb}^{-1}$ , but has a strong radial dependence and may be up to three times higher in the innermost strands of the cable. With these

estimates in mind we have assumed that the magnets and all other equipment for the Phase-I upgrade must comply with a lifetime of at least  $500 \text{ fb}^{-1}$ . This integrated luminosity is compatible with the lifetime of the ATLAS and CMS experiments before their full upgrade (Phase-II), planned for later in the next decade.

A compulsory requirement for the design of the new triplets is strict application of ALARA principles. This is in particular the case for the interconnects, which have to be designed such that their servicing and disconnection can be done with tooling adapted for work in radiation environment. The materials used for magnet construction, in particular the steels, have to be checked for traces of cobalt to limit activation.

A further consequence of high luminosities is the expected level of hadron fluence in the tunnel and in surrounding areas where electronics equipment will be housed. Following the CNGS run in 2007, which has revealed that high energy charged hadrons ( $>20 \text{ MeV}$ ) may provoke electronics failure due to single event upsets with higher probability than previously assumed, a campaign has begun at CERN to estimate the hadron fluence in LHC underground areas. The information available at present indicates that the alcoves close to ATLAS and CMS may be exposed to high fluence. Appropriate solutions are being looked at.

### *Tunnel integration*

As mentioned beforehand, the power converters and quench protection equipment for the present triplets are housed in the alcoves, while the feedboxes and cryogenic instrumentation are in-line with the triplet or below the cryostats. Unfortunately, the equipment layout around ATLAS and CMS is not identical. In fact, the equipment alcoves on the two sides of CMS are quite different, while they are symmetric in ATLAS. As one could expect with civil engineering, the beam tunnels are different too! This has all led to a situation where the feedboxes and the layout of the equipment are different for all triplets in the LHC. The design goal for the Phase-I upgrade is to at least have identical feedboxes for all four triplets, since it is unlikely that the layout of other equipment can be standardized.

The available space in the alcoves is shared with other machine equipment and is almost fully occupied. Nevertheless, in reviewing the situation it has been possible to identify appropriate locations for the new power converters, feedboxes and protection equipment. For ATLAS, the space reserved includes the UJ caverns (ground and first floors), the UL passageway, as well as the US cavern, which is mostly used for the ATLAS electrical equipment. The situation in CMS is more difficult, and at present the most promising solution is to place all the equipment in the UL by-pass, which serves for magnet transport and is presently empty. In both cases, additional studies are necessary to find the appropriate solutions to reduce the length of the cold links while keeping most of the equipment in low radiation areas. Minimal civil engineering may still be necessary.

### *Matching sections*

The present matching sections comprise three stand-alone superconducting magnets separated by warm sections, which contain the collimators, beam instrumentation and vacuum equipment, as well as elements of the energy extraction system for the main dipole circuits in the adjacent arcs. The area is also used for forward physics experiments that need direct access to the beam-line. An example of the complexity and congestion is shown in Fig. 4 for the section between the TAN and D2 dipole. Most of this equipment will remain in service after the Phase-I upgrade.

The magnets in the matching section are cooled in a saturated helium bath at 4.5 K and are powered through a superconducting link which is about 120 m long. Studies made during the LHC design have determined that a change of their operating temperature to 1.9 K is technically very difficult due to the limited size of the QRL “jumpers” and increased number of connections to the headers that would be required in this case. In the arcs, these connections are distributed over several cells. The increase of the strength or of the temperature margin of the magnets is therefore not feasible without considerable complications. For all these reasons it has been decided that the design of the insertions for the Phase-I upgrade should proceed assuming that the magnets and their operating margins remain unchanged.

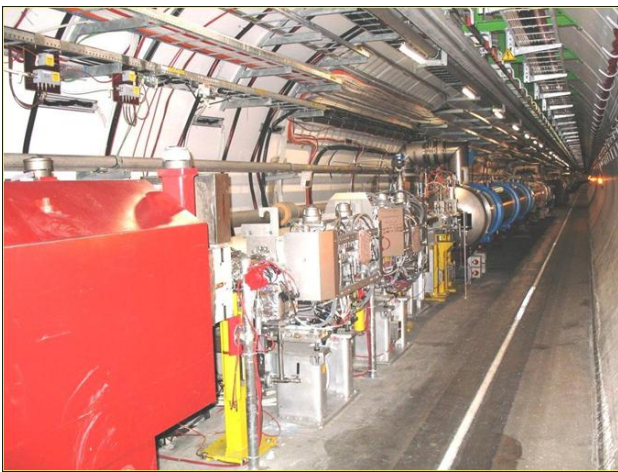

Figure 4: Beam instrumentation, collimators and other equipment presently installed in between the TAN (red object on the left) and the D2 separation dipole (blue cryostat on the right) in the ATLAS matching section.

Reduction of  $\beta^*$  inevitably leads to tighter aperture in the matching section magnets and nearby equipment. Protection against the beam halo, which is at present assured by a pair of tertiary collimators designed to protect the triplets, will most likely need to be extended to other magnets as well. In addition, as already remarked, the TAN may very well become the limiting aperture in the insertions and will require extensive modifications. The new protection equipment and other interventions in

the matching sections (e.g. realignment of the critical warm elements) will be done during normal shutdown periods for the LHC, foreseen at the beginning of every calendar year. The design of the new equipment must take into account the implications on the background in the experiments, which is expected to be an important issue for high-luminosity runs of the LHC.

### **MAGNETS FOR THE PHASE-I UPGRADE**

The magnets for the Phase-I upgrade will extensively use the technological developments made for the LHC. Nevertheless, the design of the new magnets is not without concerns due to higher stored energy, forces and stresses, and increased heat loads and radiation dose.

#### *Quadrupoles*

The low- $\beta$  quadrupoles will use the existing LHC dipole cables arranged in a 120 mm aperture coil providing a field gradient of 120 T/m, with an operating margin of around 80%. The magnet design will also include as much as possible other materials available from the LHC production, in particular the high-strength steel for the collars and magnetic iron for the laminations. The outer diameter of the magnet will be 570 mm, equal to the outer diameter of the LHC dipole.

The quadrupoles will be cooled in static pressurized helium bath at 1.9 K with a single heat exchanger of the bayonet-type, as is presently the case for magnets in the LHC arcs. The heat exchanger will have a diameter of 95 mm, dimensioned for the ultimate cooling capacity of 500 W. The laminations will be designed to improve the heat transfer from the coil via the stand-alone collars.

With all these factors in mind, the conceptual design of the magnet is fairly well defined. Optimization studies are now on-going in view of improving the cable insulation scheme for better heat transfer. The cross-section of the coil will also be refined for robustness of the field multipoles with respect to the component tolerances. The end-spacers and quench heaters, both of which are known to be delicate components, will also be optimised and their compatibility with respect to the required radiation hardness will be ensured.

#### *Correctors*

The proposed triplet layout includes a smaller number of orbit correctors than the present triplet, with proportionally increased strength. These magnets will also serve for generating a crossing angle for the beams and their separation at the IP before collision. Hence, they are equally important as any other dipole and should be constructed with the same level of reliability and robustness in mind. The nested dipole correctors based on epoxy-impregnated coil are not considered appropriate for the Phase-I performance goals and other solutions using Rutherford-type cables are being investigated. Besides helium transparency, this type of coils should also profit from larger temperature margin offered by the 1.9 K cooling. However, their design requires careful optimization and must include the full powering circuit, in

particular the power converter which will necessarily need to provide higher currents than the present 600 A.

Higher order multipole correctors are also foreseen for the Phase-I upgrade. Their specification will be based on the field quality estimates for the low- $\beta$  quadrupoles and D1 dipole, presently in discussion. The skew quadrupole and sextupole correctors are expected to have similar strengths as the present ones, and hence their design will follow the established techniques. Care will be taken to provide better protection and improved radiation hardness.

### *D1 dipoles*

The present D1 separation dipole comprises six normal conducting magnets with a pole gap of 63 mm. Clearly, the magnet gap must be increased to match the aperture of the triplet. Recent cost estimates have determined that the most effective solution for the D1 dipole is a superconducting magnet with a field in the 4 T range.

The preferred solution for D1 dipoles is to use the well established DX magnet, which has been serving well in RHIC since many years. This magnet has a coil aperture of 180 mm with a warm bore of 140 mm [9], which is more than enough for the Phase-I purposes. The DX operating field is 4.4 T and its magnetic length 3.7 m. Two such magnets are necessary for the D1, which will be about 10 m long, as shown in Fig. 2. The magnet will be cooled at 4.5 K and could be either a semi- or a fully stand-alone unit. The parameters of the magnet are such that it could remain in the insertions for the Phase-II upgrade. Discussions are presently ongoing with BNL and US-DOE to determine the possibilities of constructing the D1 cryo-dipoles as part of the US contribution to the LHC upgrade.

## PROJECT ORGANIZATION AND COLLABORATIONS

The LHC IR upgrade Phase-I is organized as a CERN project since the beginning of 2008. In this framework, the work-packages have been defined with clear technical goals and milestones. Project engineers have been assigned and preliminary estimates of the necessary resources and costs have been made. This structure will be updated following the conceptual design review (July 2008). Communication within the project is assured by regular plenary meetings chaired by the project leader. The quality assurance of the technical specifications and change control will use the EDMS and EVM systems developed for the LHC.

The project plan foresees that the production of the low- $\beta$  quadrupoles, their cryostating and cold testing is performed in CERN workshops and testing facilities. Nonetheless, to profit from the engineering expertise in other institutions, CERN has invited European and US laboratories to contribute significantly to the Phase-I upgrade. As a result, as part of the "SLHC-Preparatory Phase" project (CNI, 7<sup>th</sup> EU Framework Programme), other European laboratories (CEA and CNRS-France,

CIEMAT-Spain, STFC-UK) will participate in the design of the quadrupoles, correctors and associated production tooling. Furthermore, within the special French contribution to the implementation of the European strategy for particle physics (CERN "White paper"), a considerable participation of CEA and CNRS is foreseen in providing the components for magnets and cryostats and manufacture of the correctors. These two collaborations are well under way, with formal agreements already signed and in effect. It is also expected that the US laboratories, which have contributed decisively to the construction of the present LHC triplets, will participate in the LHC upgrade, both Phase-I and Phase-II. Discussions with the American partners are ongoing and it is expected that for Phase-I they will provide the D1 magnets and a significant part of the cold powering system.

## CONCLUSIONS

In the first few years of operation it is expected that the LHC luminosity will gradually increase and that the collider will reach its nominal performance. In order to facilitate continued improvement, several upgrade projects have been launched both for the injector chain and the LHC itself. The Phase-I upgrade of the ATLAS and CMS interaction regions is focused on removing the known bottlenecks in the low- $\beta$  triplets and enabling reliable operation of the machine at the luminosity of  $2\text{-}3 \cdot 10^{34} \text{ cm}^{-2}\text{s}^{-1}$ , limited by the existing cryogenic capacity. The implementation of the upgrade is foreseen in 2013, when Linac4, the first section of the new injection chain will also come into operation. It is also expected that ATLAS and CMS will perform substantial modifications at this time to prepare for higher even rates. The shortest route for providing the new low- $\beta$  quadrupoles in this time frame is to use the available LHC dipole cable and the existing technology of 1.9 K cooling. The Phase-I upgrade project is now in place to achieve this ambitious goals.

## REFERENCES

- [1] The European strategy for particle physics, CERN/2685.
- [2] R. Garoby, Proc. EPAC'08, Genoa, Italy (2008), p.3734.
- [3] R. Ostojic et al, Proc. PAC'05, Knoxville, TN (2005), p.2798.
- [4] LHC Design Report, CERN-2004-003.
- [5] R. Assmann, private communication.
- [6] S. Fartoukh, to be published.
- [7] N. Mokhov et al, LHC Project Report 633, Apr 2003.
- [8] E. Wildner et al, Proc. EPAC08, Genoa, Italy (2008), p. 2584, and p.2590.
- [9] M. Anarella et al., NIM A499(2003)280-315.