

### III. RADIO ASTRONOMY\*

|                     |                      |                    |
|---------------------|----------------------|--------------------|
| Prof. A. H. Barrett | R. J. Allen          | M. A. Palfy        |
| Prof. J. W. Graham  | R. K. Breon          | S. M. Rezende      |
| Prof. M. Loewenthal | Patricia P. Crowther | A. E. E. Rogers    |
| Prof. R. P. Rafuse  | A. B. Hull           | J. H. Spoor        |
| Dr. D. H. Staelin   | W. B. Lenoir         | D. H. Steinbrecher |
| Dr. S. H. Zisk      | J. M. Moran, Jr.     | A. Vander Vorst    |

#### A. MEASUREMENTS OF THE MICROWAVE SPECTRUM OF VENUS NEAR 1-cm WAVELENGTH

During June and July, 1964, observations were made of the planet Venus<sup>1</sup> at 9-14 mm wavelengths. These observations were made with the use of the Research Laboratory of Electronics five-channel microwave radiometer<sup>2</sup> mounted in the 28-ft millimeter wavelength antenna at Lincoln Laboratory, M. I. T. The frequencies 21.9, 23.5, 25.5, 29.5, and 32.4 Gc/sec were observed simultaneously; the frequency 21.1 Gc/sec was observed separately with a one-channel radiometer.

The spectral measurements were made by comparing the radio spectrum of Venus with that of the moon. The moon was observed on 17 days during the experimental period. In order to relate the observations of Venus to those of the moon, antenna patterns and values of the atmospheric absorption as a function of frequency were required. The antenna pattern at each frequency was measured with a test signal source mounted on a tower, 6 miles from the antenna site. The antenna was suitably defocused for these measurements, and cross-polarization patterns were also measured. The atmospheric opacity was determined by a series of solar extinction measurements which were used to relate the opacity to the ground-level humidity. This empirically determined relationship was then used to determine the appropriate atmospheric opacity at any given time.

The results obtained on each day are summarized in Table III-1. In the table,  $T_{BV}$ (°K) is the average brightness temperature of the visible disk of Venus.  $\sigma$ (%) is the estimated standard deviation of the measured signal from its true value and does not include uncertainties introduced by atmospheric absorption, antenna pointing, and so forth.

If all of the separate observations are averaged together, and each is weighted by its estimated accuracy, then the results listed in Table III-2 are obtained.

The absolute error presented in Table III-2 includes all sources of error; measurements made at different frequencies are considered to be independent. The relative error includes only those components of error that are independent from channel to channel.

---

\*This work was supported in part by the National Aeronautics and Space Administration (Grant NsG-419).

Table III-1. Observed brightness temperature of Venus as a function of date.

| Date<br>1964 | 32.4 (Gc/sec)        |       | 29.5            |    | 25.5            |    | 23.5            |    | 21.9            |    | 21.1            |    |
|--------------|----------------------|-------|-----------------|----|-----------------|----|-----------------|----|-----------------|----|-----------------|----|
|              | T <sub>BV</sub> (°K) | σ (%) | T <sub>BV</sub> | σ  | T <sub>BV</sub> | σ  | T <sub>BV</sub> | σ  | T <sub>BV</sub> | σ  | T <sub>BV</sub> | σ  |
| 6/5          | 458                  | 3     | 501             | 10 | 518             | 6  | 445             | 5  | 353             | 17 | —               | —  |
| 6/11         | 418                  | 5     | 415             | 12 | 449             | 9  | 421             | 7  | 436             | 14 | —               | —  |
| 6/12         | 403                  | 7     | 463             | 8  | 442             | 13 | 440             | 13 | 389             | 21 | —               | —  |
| 6/12         | 420                  | 10    | 395             | 14 | 449             | 7  | 482             | 5  | 358             | 24 | —               | —  |
| 6/29         | 513                  | 17    | 307             | 17 | 482             | 12 | 412             | 7  | 527             | 25 | —               | —  |
| 7/5          | 467                  | 52    | 584             | 8  | —               | —  | 406             | 7  | 350             | 14 | —               | —  |
| 7/6          | 522                  | 17    | 549             | 16 | 439             | 6  | 513             | 5  | 482             | 12 | —               | —  |
| 7/7          | 422                  | 13    | 400             | 25 | 493             | 9  | 427             | 9  | 377             | 22 | —               | —  |
| 7/8          | 428                  | 6     | 505             | 10 | 403             | 5  | 381             | 10 | 375             | 6  | —               | —  |
| 7/11         | 312                  | 18    | 421             | 22 | 344             | 8  | 518             | 6  | 359             | 18 | —               | —  |
| 7/15         | —                    | —     | —               | —  | —               | —  | —               | —  | —               | —  | 495             | 12 |
| 7/16         | 477                  | 8     | 457             | 17 | 409             | 6  | 220             | 30 | —               | —  | —               | —  |
| 7/17         | —                    | —     | —               | —  | —               | —  | —               | —  | —               | —  | 524             | 13 |
| 7/18         | —                    | —     | —               | —  | —               | —  | —               | —  | —               | —  | 528             | 9  |
| 7/27         | 322                  | 23    | 499             | 40 | 385             | 8  | 474             | 18 | 518             | 12 | —               | —  |
| 7/30         | 346                  | 17    | 374             | 44 | 417             | 10 | 535             | 11 | 491             | 14 | —               | —  |

Table III-2. Averaged and weighted results.

| (Gc/sec) | $T_{BV}$ (°K) | Relative error (°K) | Absolute error (°K) |
|----------|---------------|---------------------|---------------------|
| 32.4     | 430           | ±24                 | ±42                 |
| 29.5     | 463           | ±32                 | ±68                 |
| 25.5     | 428           | ±20                 | ±46                 |
| 23.5     | 450           | ±23                 | ±41                 |
| 21.9     | 404           | ±28                 | ±39                 |
| 21.1     | 502           | ±82                 | ±100                |

The results are also presented in Fig. III-1, together with the results of other observers made during several inferior conjunctions. One theoretical spectrum was computed for a cloud layer that is uniform from 465°K to 270°K, with absorption coefficient proportional to the square of the frequency. A similar spectrum would be expected from water clouds. The second theoretical spectrum is for nonresonant absorption by a 10% CO<sub>2</sub>-90% N<sub>2</sub> atmosphere with surface pressure approximately 150 atmospheres.

The 32.4 and 29.5 Gc/sec data points are 1.5 and 1.7 standard deviations above the nonresonant spectrum, respectively, and the 21.9 Gc/sec measurement is 2.0 standard deviations below the same curve. Even if the absolute error brackets are used, the

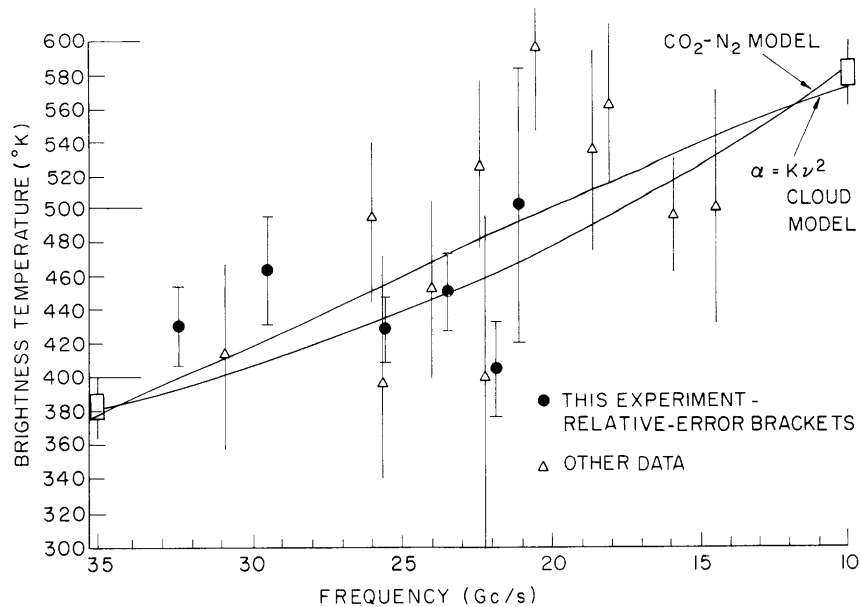

Fig. III-1. Microwave spectrum of Venus near 1-cm wavelength.

### (III. RADIO ASTRONOMY)

displacements are  $0.9$ ,  $0.8$ , and  $1.4\sigma$ , respectively. The probability of being farther than  $1.5$  standard deviations from the correct value is approximately  $0.13$ , and the probability of being farther than  $2.0$  standard deviations is approximately  $0.05$ . Thus if the relative error brackets are used, it is unlikely that the microwave spectrum of Venus is nonresonant in character over this spectral region.

Atmospheric models in better agreement with the data are those having molecular resonances in the millimeter wavelength region. Also, models incorporating scattering are in agreement. A study of these models is in progress.

D. H. Staelin, A. H. Barrett

#### References

1. D. H. Staelin, Sc.D. Thesis, Department of Electrical Engineering, Massachusetts Institute of Technology, January 1965.
2. D. H. Staelin, Quarterly Progress Report No. 69, Research Laboratory of Electronics, M. I. T., April 15, 1963, pp. 23-25.

### B. OBSERVATIONS OF MICROWAVE EMISSION FROM ATMOSPHERIC OXYGEN

Two more balloon flights<sup>1,2</sup> were undertaken from Palestine, Texas, in the fall of 1964. The first, Flight No. 88P, on 29 October, was partially successful. The second, Flight No. 89P, on 8 November, was completely successful, yielding good data for the entire flight.

#### 1. Flight Radiometer

The radiometer is basically the same as the one used in previous flights. See Fig. III-2. For these flights the telemeter was operating, giving a real-time data output.

The errors are the sum of a consistent error (constant over the duration of the flight) and a random noise. The consistent error varies from  $\pm 8^\circ\text{K}$  for a brightness temperature of  $0^\circ\text{K}$  to  $\pm 1^\circ\text{K}$  for a brightness temperature of  $300^\circ\text{K}$ . The rms temperature variation of the radiometer is approximately  $1^\circ\text{K}$  on each channel.

#### 2. Results

##### Flight No. 88P, 29 October 1964

This flight was only partially successful. Data were recovered from the 20-Mc and 200-Mc IF channels during a period of 2 hours (approximately the time for ascending to float altitude 30 km), and from the 60-Mc IF channel for the first 20 minutes and the last 20 minutes of the first 2 hours.

After 2 hours, the programmer assumed a supposedly unallowed state and began

(III. RADIO ASTRONOMY)

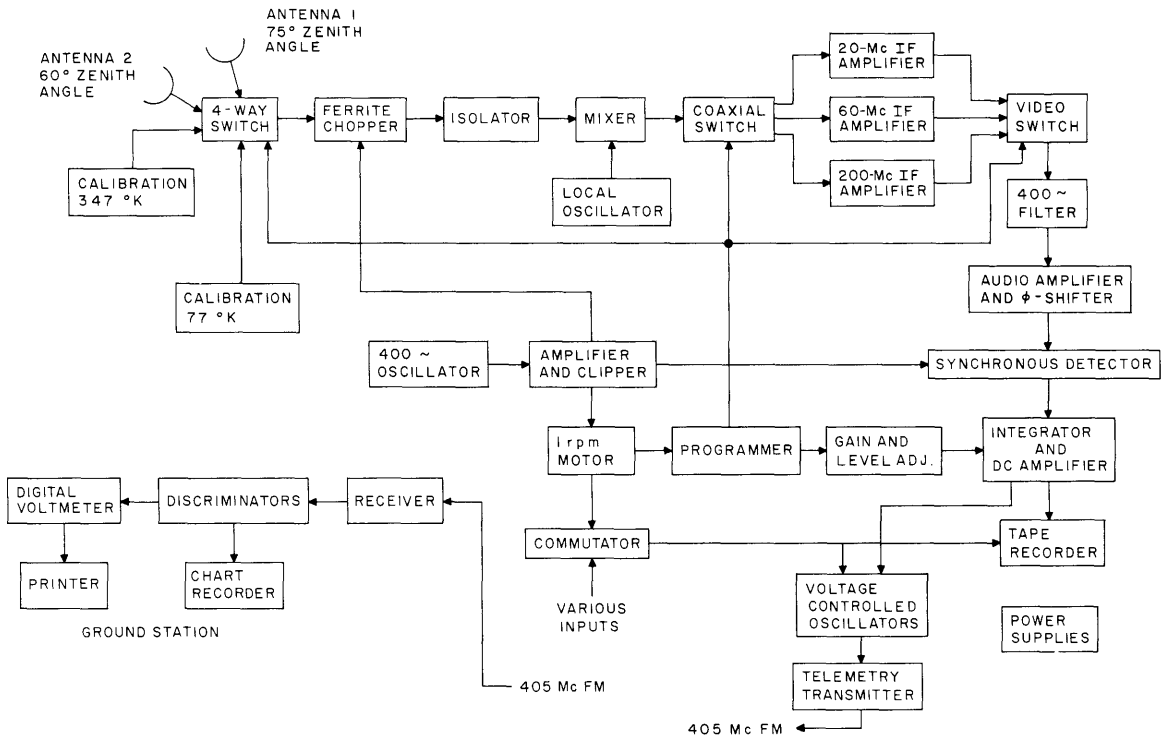

Fig. III-2. Flight radiometer.

switching between the calibration loads only. The difficulty in the 60-Mc IF channel was traced to a faulty relay which evidently failed after 20 minutes and then began to perform properly after one hour of failure.

Telemetry apparatus permitted the malfunctions to be viewed as they were happening. As soon as the programmer malfunction was diagnosed, the flight was terminated.

The small amount of data from flight No. 88P has not been reduced yet.

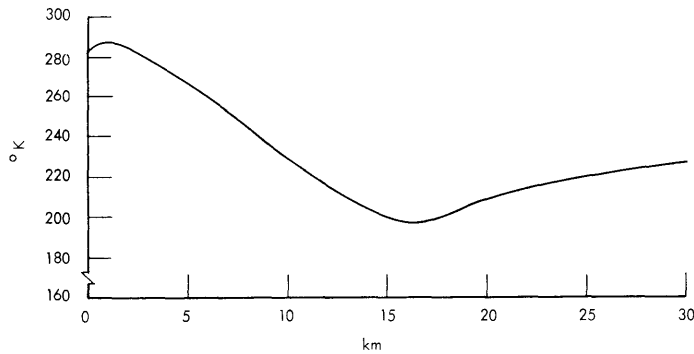

Fig. III-3. Flight No. 89P atmospheric temperature vs height.

(III. RADIO ASTRONOMY)

Flight No. 89P, 8 November 1964

The erratic relay was replaced and the programmer's difficulty was solved by use of a mechanical commutator. The profile of the flight was the following.

1. Approximate linear ascent to 30 km in 2 hours.
2. Float at 30 km for 4 hours.

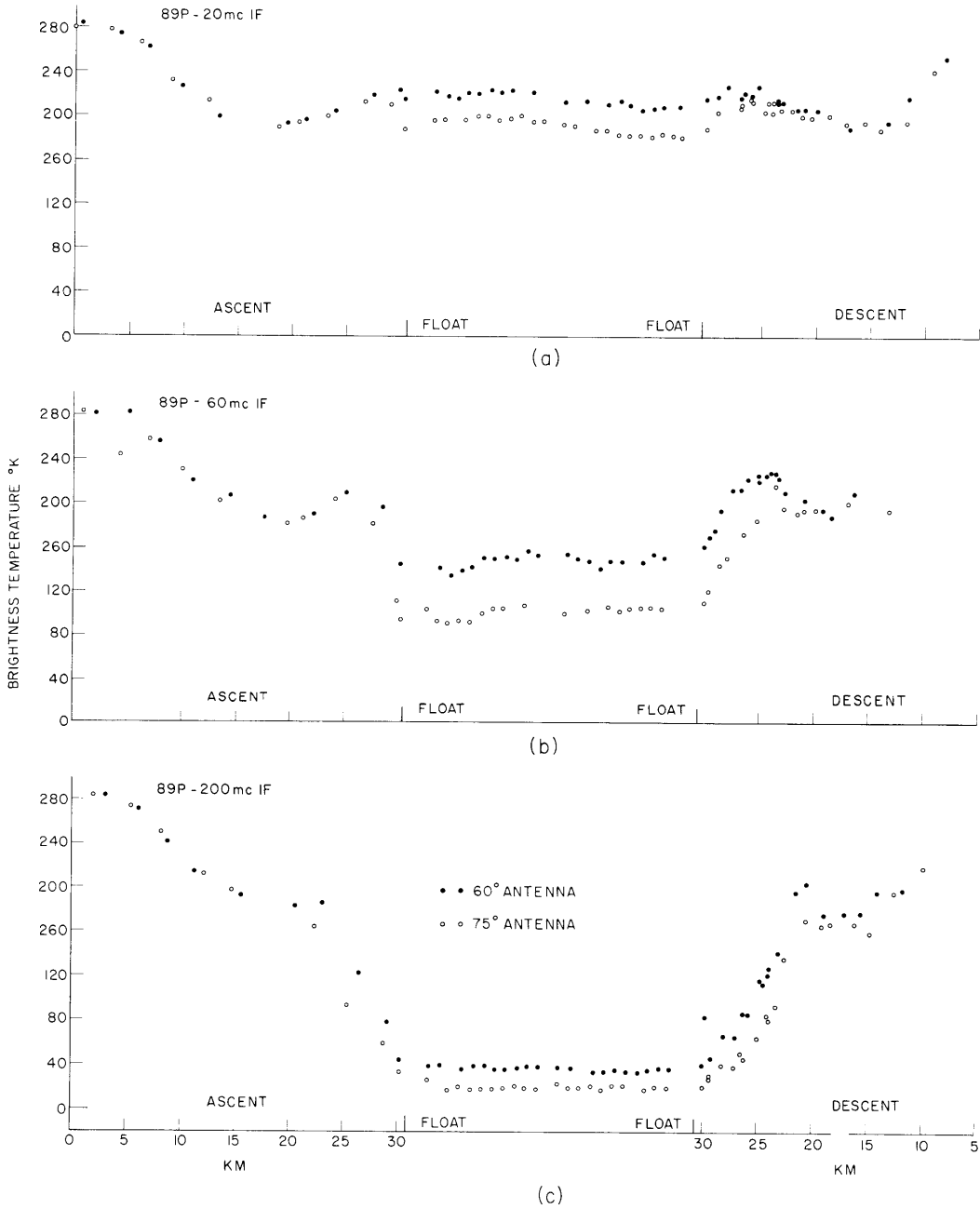

Fig. III-4. Flight No. 89P brightness temperatures vs height.

3. Approximate linear descent to 5.5 km in 3 hours.
4. Parachute to ground.

The atmospheric temperature versus height as measured during the flight is shown in Fig. III-3.

Data were taken in three ways:

1. At the balloon base with the master receiver as indicated in the block diagram of Fig. III-2.
2. In a car, equipped with a receiver and a chart recorder, following the path of the balloon.
3. On a tape recorder in the flight gondola.

Data taken by method 1 were the most accurate because of the resolution it afforded. Data taken by method 2 was the least accurate because the chart recording could only be read to  $\pm 5^\circ\text{K}$ , while the radiometer noise was only  $\pm 1^\circ\text{K}$ . Data taken by method 2 should eventually be as accurate as that taken by method 1. Tape-recorder malfunctions have prevented getting all of the data from the tape.

The brightness temperatures versus height for the three IF channels and the two antenna angles are shown in Fig. III-4.

The six brightness temperatures averaged over the duration of the flight at float altitude are given in Table III-3.

Table III-3. Float brightness temperature averages.

| Channel   | 60° Antenna | 75° Antenna |
|-----------|-------------|-------------|
| 20 Mc IF  | 190°K       | 215°K       |
| 60 Mc IF  | 102°K       | 148°K       |
| 200 Mc IF | 19°K        | 36°K        |

Work continues on further interpretation of these data. In particular, work is under way to see how much information can be obtained about the atmospheric thermal structure above float height, to see what can be inferred about the linewidth, and what can be said about the line intensity.

Another series of flights is planned tentatively for Summer 1965 with improvements that should lower the temperature sensitivity to less than  $2^\circ\text{K}$  for all brightness temperatures.

W. B. Lenoir

#### References

1. W. B. Lenoir and J. W. Kuiper, Quarterly Progress Report No. 75, Research Laboratory of Electronics, M. I. T., October 15, 1964, pp. 9-18.
2. A. H. Barrett, J. C. Blinn III, and J. W. Kuiper, Quarterly Progress Report No. 71, Research Laboratory of Electronics, M. I. T., October 15, 1963, pp. 69-76.

### (III. RADIO ASTRONOMY)

#### C. MATRIX FORMULATION OF RADIATIVE TRANSFER

In many cases of practical interest the emission and absorption properties of a medium depend on the polarization of the radiation. In these cases, for a general treatment, it does not suffice to treat the radiative transfer in the framework of the scalar equation of radiative transfer. A new treatment must be developed which includes polarization information, as well as intensity information. This report concerns such a development. It is assumed that a spatially and angularly incoherent TEM wave traveling in the +Z direction is being dealt with.

##### 1. Coherency Spectrum Matrix

The electric field can be written

$$\vec{\mathcal{E}}(t) = \vec{\mathcal{E}}_{\alpha}(t) + \vec{\mathcal{E}}_{\beta}(t) \quad (1)$$

in which the subscripts  $\alpha$  and  $\beta$  indicate the components of  $\vec{\mathcal{E}}(t)$  with polarization  $\alpha$  and  $\beta$ , respectively, with  $\alpha$  and  $\beta$  being any two opposite polarizations. They will be called a "polarization basis."

Samples of  $\mathcal{E}_{\alpha}(t)$  and  $\mathcal{E}_{\beta}(t)$  that are of T duration will have Fourier Transforms given by

$$E_{\alpha, T}(\nu) = \int_{-T/2}^{T/2} \mathcal{E}_{\alpha}(t) e^{-i2\pi\nu t} dt \quad (2a)$$

$$E_{\beta, T}(\nu) = \int_{-T/2}^{T/2} \mathcal{E}_{\beta}(t) e^{-i2\pi\nu t} dt. \quad (2b)$$

The Fourier transform of the corresponding sample of  $\vec{E}_T(t)$ , also of T duration, can be written as a vector in the two-dimensional vector space of polarizations.

$$E_T(\nu) = \begin{pmatrix} E_{\alpha, T}(\nu) \\ E_{\beta, T}(\nu) \end{pmatrix} \quad (3)$$

A "coherency spectrum matrix" can now be defined as

$$\underline{\underline{J}}(\nu) = \overline{\left( \lim_{T \rightarrow \infty} \frac{E_T(\nu) E_T^{t*}(\nu)}{T} \right)} \quad (4)$$

in which  $\underline{\underline{J}}$  denotes that J is a matrix, t denotes transpose, \* denotes complex conjugate, and the bar over the relation denotes the ensemble average.<sup>1</sup> This  $\underline{\underline{J}}(\nu)$  is related to the coherency matrix of Wolf<sup>2</sup> but does not require a narrow-band assumption.

Substitution of (3) in (4) yields



$$\underline{\underline{J}}(\nu) = \begin{pmatrix} \left[ \lim_{T \rightarrow \infty} \frac{|E_{\alpha, T(\nu)}|^2}{T} \right] & \left[ \lim_{T \rightarrow \infty} \frac{E_{\alpha, T(\nu)} E_{\beta, T(\nu)}^*}{T} \right] \\ \left[ \lim_{T \rightarrow \infty} \frac{E_{\alpha, T(\nu)}^* E_{\beta, T(\nu)}}{T} \right] & \left[ \lim_{T \rightarrow \infty} \frac{|E_{\beta, T(\nu)}|^2}{T} \right] \end{pmatrix}. \quad (5)$$

Through use of the relation for power spectral density

$$\Phi_{ij}(\nu) = \left[ \lim_{T \rightarrow \infty} \frac{E_{i, T(\nu)} E_{j, T(\nu)}^*}{T} \right], \quad (6)$$

Eq. 5 becomes

$$\underline{\underline{J}}(\nu) = \begin{pmatrix} \Phi_{\alpha\alpha}(\nu) & \Phi_{\alpha\beta}(\nu) \\ \Phi_{\beta\alpha}(\nu) & \Phi_{\beta\beta}(\nu) \end{pmatrix} \quad (7)$$

which is more general, since  $\Phi_{ij}(\nu)$  is defined for random noiselike fields, whereas  $E(\nu)$  is not.

Examination of (7), or equivalently of (5), shows at once that  $\underline{\underline{J}}(\nu)$  is Hermitian (self-adjoint), that is,  $\underline{\underline{J}}(\nu) = \underline{\underline{J}}(\nu)^{t*}$ . It is also obvious that  $\Phi_{\alpha\alpha}(\nu)$  and  $\Phi_{\beta\beta}(\nu)$  are real and non-negative.  $\Phi_{\alpha\alpha}(\nu)$  and  $\Phi_{\beta\beta}(\nu)$  are the power spectral densities in polarizations  $\alpha$  and  $\beta$ , respectively. Hence the trace of  $\underline{\underline{J}}(\nu)$ ,

$$\text{tr } \underline{\underline{J}}(\nu) = \Phi_{\alpha\alpha}(\nu) + \Phi_{\beta\beta}(\nu) \geq 0, \quad (8)$$

is the total power spectral density of the radiation.

The off-diagonal terms,  $\Phi_{\alpha\beta}(\nu)$  and  $\Phi_{\beta\alpha}(\nu)$ , measure the degree of coherence between the radiation with polarization  $\alpha$  and that with polarization  $\beta$ . By Schwartz' inequality, the determinant of  $\underline{\underline{J}}(\nu)$ ,

$$\det \underline{\underline{J}}(\nu) = \Phi_{\alpha\alpha}(\nu) \Phi_{\beta\beta}(\nu) - \Phi_{\alpha\beta}(\nu) \Phi_{\beta\alpha}(\nu), \quad (9)$$

is real and non-negative.

The analysis thus far has assumed  $\alpha, \beta$  to be the polarization basis. The change from one polarization basis  $\alpha, \beta$  to another,  $x, y$ , is effected through a unitary transformation,  $U$ .

$$\begin{pmatrix} E_{x, T(\nu)} \\ E_{y, T(\nu)} \end{pmatrix} = \underline{\underline{U}} \begin{pmatrix} E_{\alpha, T(\nu)} \\ E_{\beta, T(\nu)} \end{pmatrix} \quad (10)$$

This changes only the polarization basis in which the radiation is described. It does not change the radiation itself in any way.

From (5) and (10), the coherency spectrum matrix is transformed to the basis  $x, y$

(III. RADIO ASTRONOMY)

through

$$\underline{\underline{J}}_{x,y}(\nu) = \underline{\underline{U}} \underline{\underline{J}}_{\alpha,\beta}(\nu) \underline{\underline{U}}^{t*}. \quad (11)$$

From which it is obvious that  $\underline{\underline{J}}_{x,y}(\nu)$  is Hermitian, since  $\underline{\underline{J}}_{\alpha,\beta}(\nu)$  is.

From the properties of unitary transformations it can be shown that the trace, determinant, and eigenvalues are invariant under a transformation such as (11). So that  $\text{tr } \underline{\underline{J}}(\nu)$ ,  $\det \underline{\underline{J}}(\nu)$ ,  $\lambda_1(\nu)$ ,  $\lambda_2(\nu)$  are the trace, determinant, and eigenvalues of  $\underline{\underline{J}}(\nu)$  in any polarization basis.

Then there exists a unitary transformation,  $\underline{\underline{U}}_D(\nu)$  to a polarization basis,  $m, n$  in which  $\underline{\underline{J}}(\nu)$  is diagonal.

$$\underline{\underline{J}}_{m,n}(\nu) = \underline{\underline{U}}_D(\nu) \underline{\underline{J}}_{\alpha,\beta}(\nu) \underline{\underline{U}}_D^{t*}(\nu) = \begin{pmatrix} J_m(\nu) & 0 \\ 0 & J_n(\nu) \end{pmatrix} \quad (12)$$

with  $J_m(\nu) = \lambda_1(\nu)$  and  $J_n(\nu) = \lambda_2(\nu)$ . Assuming, with no loss of generality, that  $J_m(\nu) \geq J_n(\nu)$ , we have

$$\underline{\underline{J}}_{m,n}(\nu) = J_n(\nu) \begin{pmatrix} 1 & 0 \\ 0 & 1 \end{pmatrix} + [J_m(\nu) - J_n(\nu)] \begin{pmatrix} 1 & 0 \\ 0 & 0 \end{pmatrix}, \quad (13)$$

where both matrices on the right are valid coherency spectrum matrices.

The first is seen to be that of a randomly polarized (unpolarized) wave; while the second is that of a totally polarized wave with polarization  $m$ . Such a decomposition exists uniquely (through a function of  $\nu$  in general) for all coherency spectrum matrices.

The fractional polarization spectrum can now be defined as the power spectral density of the polarized part divided by the total power spectral density

$$p(\nu) = \frac{J_m(\nu) - J_n(\nu)}{J_m(\nu) + J_n(\nu)}. \quad (14)$$

Here,  $p(\nu)$  is independent of the polarization basis and is given more generally by

$$p(\nu) = \sqrt{1 - \frac{4 \det \underline{\underline{J}}(\nu)}{[\text{tr } \underline{\underline{J}}(\nu)]^2}}. \quad (15)$$

In radio astronomy it is often convenient to use the concept of brightness temperature, rather than intensity or spectral flux density. For the scalar description, the brightness temperature (in the microwave region with  $h\nu \ll kT$ ) is defined by

$$I(\nu) = \frac{2k\nu^2 T_B(\nu)}{c^2}, \quad (16)$$

where  $I$  is the intensity;  $T_B$ , the brightness temperature;  $k$ , Boltzmann's constant; and  $c$ , the velocity of light.

It will also be convenient to define a brightness-temperature coherency spectrum matrix in similar fashion. Since  $2k\nu^2/c^2$  is constant (for a given  $\nu$ ), and  $\underline{\underline{J}}(\nu)$  is the intensity coherency spectrum matrix (except for a multiplicative constant), we may define

$$\underline{\underline{T}}_B(\nu) = \text{const}(\nu) \underline{\underline{J}}(\nu) \quad (17)$$

as the brightness-temperature coherency spectrum matrix. Thus on the polarization basis,  $\alpha, \beta$

$$\underline{\underline{T}}_B(\nu) = \begin{pmatrix} T_{\alpha\alpha}(\nu) & T_{\alpha\beta_R}(\nu) + iT_{\alpha\beta_I}(\nu) \\ T_{\alpha\beta_R}(\nu) - iT_{\alpha\beta_I}(\nu) & T_{\beta\beta}(\nu) \end{pmatrix}, \quad (18)$$

where  $T_{\alpha\alpha}(\nu)$  and  $T_{\beta\beta}(\nu)$  are the brightness temperatures (in a scalar sense) of the radiation with polarizations  $\alpha$  and  $\beta$ . The general properties of  $\underline{\underline{J}}(\nu)$  apply also to  $\underline{\underline{T}}_B(\nu)$ .

In particular, the fraction polarization spectrum,  $p(\nu)$ , is unchanged.

$$p(\nu) = \sqrt{1 - \frac{4 \det \underline{\underline{T}}_B(\nu)}{[\text{tr} \underline{\underline{T}}_B(\nu)]^2}}. \quad (19)$$

## 2. Matrix Equation of Radiative Transfer

The propagation of the brightness-temperature coherency spectrum matrix through a medium will now be considered. The medium is assumed to be only slightly inhomogeneous (the properties of the medium vary only slightly over a wavelength's distance).

Then a complex propagation matrix,  $\underline{\underline{A}}(\nu)$ , that is the matrix equivalent of the scalar

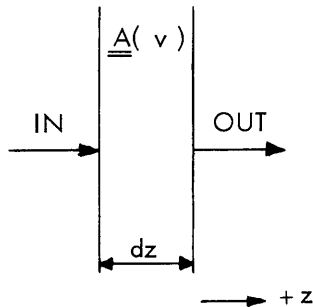

Fig. III-5. Geometry for a slab of infinitesimal thickness.

complex propagation constant can be defined.  $\underline{\underline{A}}(\nu)$  describes the absorption and propagation properties of the medium and, in general, will be a function of position (subject

(III. RADIO ASTRONOMY)

to the slightly inhomogeneous assumption).

The relations for the geometry of Fig. III-5 are

$$\underline{E}_{\text{out}}(\nu) = [\underline{I} - \underline{A}(\nu) dz] \underline{E}_{\text{in}}(\nu) \quad (20)$$

with  $\underline{I} = \begin{pmatrix} 1 & 0 \\ 0 & 1 \end{pmatrix}$  and  $\underline{A}(\nu)$  is the complex propagation matrix. This equation is consistent with Maxwell's equations (assuming small loss and only slight inhomogeneities).  $\underline{A}(\nu)$  can be found in terms of  $\underline{\epsilon}(\nu)$ ,  $\underline{\mu}(\nu)$ ,  $\underline{\sigma}(\nu)$  which appear in the matrix formulation of Maxwell's equations.

From (20) and (5) we obtain

$$\underline{J}_{\text{out}}(\nu) = \underline{J}_{\text{in}}(\nu) - \underline{A}(\nu) \underline{J}_{\text{in}}(\nu) dz - \underline{J}_{\text{in}}(\nu) \underline{A}^{t*}(\nu) dz + \underline{A}(\nu) \underline{J}_{\text{in}}(\nu) \underline{A}^{t*}(\nu) dz^2.$$

Letting  $d\underline{J}(\nu) = \underline{J}_{\text{out}}(\nu) - \underline{J}_{\text{in}}(\nu)$  and taking  $\lim_{dz \rightarrow 0}$  yields

$$\frac{d}{dz} \underline{J}(\nu) + \underline{A}(\nu) \underline{J}(\nu) + \underline{J}(\nu) \underline{A}^{t*}(\nu) = 0. \quad (21)$$

Equation 21 is the matrix equation of radiative transfer in which emission from the medium has been ignored.

The equivalent equation in brightness temperature notation is

$$\frac{d}{dz} \underline{T}_B(\nu) + \underline{A}(\nu) \underline{T}_B(\nu) + \underline{T}_B(\nu) \underline{A}^{t*}(\nu) = 0. \quad (22)$$

Consider the propagation through a slab of finite thickness with  $\underline{A}(\nu)$  independent of position (see Fig. III-6). The problem is to solve (22) for an incident brightness temperature coherency spectrum matrix of  $\underline{T}_{B_1}(\nu)$ .

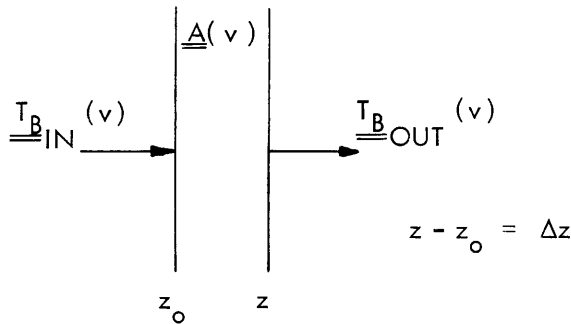

Fig. III-6. Geometry for a slab of finite thickness.

$\underline{T}_{B_1}(\nu)$  is not sufficient to specify  $E_1(\nu)$ ; nevertheless it is often useful to consider  $E_1(\nu)$  as if it were known and to convert to  $\underline{T}_{B_0}(\nu)$  only at the last step. As long as claims are made only to  $\underline{T}_{B_0}(\nu)$  and not to  $E_0(\nu)$ , this is a valid procedure.

In this manner Eq. 20 is readily solved to yield

$$E_o(\nu) = e^{-\underline{\underline{A}}(\nu)\Delta z} E_i(\nu), \quad (23)$$

where the exponential of a matrix is defined by the power series

$$e^{-\underline{\underline{A}}(\nu)\Delta z} = \sum_{n=0}^{\infty} \frac{[-\underline{\underline{A}}(\nu)\Delta z]^n}{n!}; \quad \text{with } \underline{\underline{A}}(\nu)^o = \underline{\underline{I}}. \quad (24)$$

A word of warning is in order here. Considerable care must be exercised when dealing with exponentials of matrices. Many of the familiar relations and rules governing exponentials of scalars do not apply to the exponentials of matrices. For example, if  $\underline{\underline{X}}$  and  $\underline{\underline{Y}}$  are matrices, then  $e^{\underline{\underline{X}}+\underline{\underline{Y}}} = e^{\underline{\underline{X}}}e^{\underline{\underline{Y}}}$  if and only if  $\underline{\underline{XY}} = \underline{\underline{YX}}$ , that is,  $\underline{\underline{X}}$  and  $\underline{\underline{Y}}$  commute.

Using (23), we obtain the solution for  $\underline{\underline{T}}_{B_o}(\nu)$ :

$$\underline{\underline{T}}_{B_o}(\nu) = e^{-\underline{\underline{A}}(\nu)\Delta z} \underline{\underline{T}}_{B_i}(\nu) e^{-\underline{\underline{A}}^{t*}(\nu)\Delta z}. \quad (25)$$

Thus far the possibility of emission from the medium has been ignored. To allow for it Eq. 22 can be rewritten as

$$\frac{d}{dz} \underline{\underline{T}}_B(\nu) + \underline{\underline{A}}(\nu) \underline{\underline{T}}_B(\nu) + \underline{\underline{T}}_B(\nu) \underline{\underline{A}}^{t*}(\nu) = \underline{\underline{S}}_e(\nu) \quad (26)$$

with  $\underline{\underline{S}}_e(\nu)$  being the Hermitian emission spectrum matrix.

The problem of finding  $\underline{\underline{S}}_e(\nu)$  can be solved through definition of an emission temperature spectrum matrix,  $\underline{\underline{T}}_e(\nu)$ . Consider a slab as illustrated in Fig. III-6. Then  $\underline{\underline{T}}_e(\nu)$  is defined to be the brightness temperature coherency spectrum matrix necessary to fulfill the condition that if  $\underline{\underline{T}}_{B_i}(\nu) = \underline{\underline{T}}_e(\nu)$ , then  $\underline{\underline{T}}_{B_o}(\nu) = \underline{\underline{T}}_e(\nu)$  also, independent of  $z$ . This gives

$$\underline{\underline{S}}_e(\nu) = \underline{\underline{A}}(\nu) \underline{\underline{T}}_e(\nu) + \underline{\underline{T}}_e(\nu) \underline{\underline{A}}^{t*}(\nu), \quad (27)$$

so that the emission spectrum matrix depends on the emission temperature spectrum matrix and the complex propagation properties of the medium. This is the matrix equivalent of the scalar equation<sup>4</sup>

$$j = \gamma T_e$$

in which  $j$  is the emission coefficient;  $\gamma$ , the power absorption coefficient; and  $T_e$ , the scalar emission temperature.

If the medium is the local thermodynamic equilibrium, then

$$\underline{\underline{T}}_e(\nu) = \underline{\underline{T}}_k = t_{k^2} I, \quad (28)$$

### (III. RADIO ASTRONOMY)

where  $\underline{T}_k$  is the kinetic temperature matrix,  $t_k$  the scalar kinetic temperature, and  $\underline{I}$  the  $2 \times 2$  unit matrix.

In general Eq. 26 can be written as

$$\frac{d}{dz} \underline{T}_B(\nu) + \underline{A}(\nu) \underline{T}_B(\nu) + \underline{T}_B(\nu) \underline{A}^{t*}(\nu) = \underline{A}(\nu) \underline{T}_e(\nu) + \underline{T}_e(\nu) \underline{A}^{t*}(\nu). \quad (29)$$

When Eq. 28 is valid this becomes

$$\frac{d}{dz} \underline{T}_B(\nu) + \underline{A}(\nu) \underline{T}_B(\nu) + \underline{T}_B(\nu) \underline{A}^{t*}(\nu) = t_k [\underline{A}(\nu) + \underline{A}^{t*}(\nu)]. \quad (30)$$

The solution to Eq. 29 appropriate to Fig. III-6 is

$$\underline{T}_{B_0}(\nu) = e^{-\underline{A}(\nu)\Delta z} \underline{T}_{B_1}(\nu) e^{-\underline{A}^{t*}(\nu)\Delta z} + \left[ \underline{T}_e(\nu) - e^{-\underline{A}(\nu)\Delta z} \underline{T}_e(\nu) e^{-\underline{A}^{t*}(\nu)\Delta z} \right]. \quad (31)$$

The first term in Eq. 31 represents the part of  $\underline{T}_{B_0}(\nu)$  which is due to the  $\underline{T}_{B_1}(\nu)$  that is incident on the slab. The second term refers to the emission in the interval  $(z_0, z)$  and its subsequent propagation through the rest of the slab.

For cases in which  $\underline{T}_e(\nu) = t_k \underline{I}$ , the solution becomes

$$\underline{T}_{B_0}(\nu) = e^{-\underline{A}(\nu)\Delta z} \underline{T}_{B_1}(\nu) e^{-\underline{A}^{t*}(\nu)\Delta z} + t_k \left[ \underline{I} - e^{-\underline{A}(\nu)\Delta z} e^{-\underline{A}^{t*}(\nu)\Delta z} \right]. \quad (32)$$

### 3. Finite Bandwidth Considerations

Equation 31 integrated over a finite frequency band will yield the brightness temperature coherency matrix for that center frequency,  $\nu_c$ , and that bandwidth,  $\Delta\nu$ .

$$\underline{T}_{B_0}(\nu_c, \Delta\nu) = \int_{\nu_c - \Delta\nu/2}^{\nu_c + \Delta\nu/2} \underline{T}_{B_0}(\nu) d\nu. \quad (33)$$

This  $\underline{T}_{B_0}(\nu_c, \Delta\nu)$  would describe the radiation appropriate to Eq. 31 after it had been passed through an appropriate bandpass filter.

The fractional polarization of  $\underline{T}_{B_0}(\nu_c, \Delta\nu)$  is given by

$$p(\nu_c, \Delta\nu) = \sqrt{1 - \frac{4 \det \underline{T}_{B_0}(\nu_c, \Delta\nu)}{\left[ \text{tr} \underline{T}_{B_0}(\nu_c, \Delta\nu) \right]^2}}. \quad (34)$$

Note that it is not equal to  $\int p(\nu) d\nu$ .

In general (33) represents quite a formidable integration. Special cases exist in which Eq. 33 can be greatly simplified. Physically, these cases are of great importance as they encompass the narrow-band cases.

If  $\underline{\underline{A}}(\nu)$  exhibits essentially no  $\nu$  dependence over the interval  $(\nu_c - \frac{\Delta\nu}{2}, \nu_c + \frac{\Delta\nu}{2})$ , then (33) assumes the same form as (31) with all temperature coherency spectrum matrices replaced by their integral over the bandwidth in question. That is,

$$\underline{\underline{T}}_B(\nu) \rightarrow \int_{\nu_c - \Delta\nu/c}^{\nu_c + \Delta\nu/c} \underline{\underline{T}}_B(\nu) d\nu. \quad (35)$$

For cases in which  $\underline{\underline{T}}_{B_1}(\nu)$  and  $\underline{\underline{T}}_e(\nu)$  are essentially independent of temperature over the bandwidth this reduces to

$$\underline{\underline{T}}_B(\nu) \rightarrow \underline{\underline{T}}_B(\nu_c) \Delta\nu. \quad (36)$$

#### 4. Complex Propagation Matrix for the Small-Loss Case

The assumption of small loss means that the loss mechanism absorbs an amount of power over a wavelength that is small compared with the total power of the wave. A TEM solution to Maxwell's equations is sought.

$\vec{E}(\vec{r}, \nu)$  and  $\vec{H}(\vec{r}, \nu)$  are the Fourier transforms of the electric and magnetic fields at a position indicated by  $\vec{r}$ . They can be broken into a sum of two components with opposite polarizations.

$$\vec{E}(\vec{r}, \nu) = \vec{E}_1(\vec{r}, \nu) + \vec{E}_2(\vec{r}, \nu) \quad (37a)$$

and

$$\vec{H}(\vec{r}, \nu) = \vec{H}_1(\vec{r}, \nu) + \vec{H}_2(\vec{r}, \nu). \quad (37b)$$

(Note that the subscripts refer to a polarization, not necessarily of a particular spatial direction. For example, if subscript 1 is to denote linear polarization in the x-direction, then  $\vec{E}_1(\vec{r}, \nu) = E_1(\vec{r}, \nu) \vec{i}_x$ , whereas  $\vec{H}_1(\vec{r}, \nu) = H_1(\vec{r}, \nu) \vec{i}_y$  for  $\vec{E}$  and  $\vec{H}$  corresponding to a uniform plane wave. It is also possible for subscript 1 to be right-circular polarization and for subscript 2 to be left-circular polarization. This case points out the pitfalls of coupling the spatial vectors with polarization labels.)

The representation

$$\vec{E}(\vec{r}, \nu) = \begin{pmatrix} \vec{E}_1(\vec{r}, \nu) \\ \vec{E}_2(\vec{r}, \nu) \end{pmatrix} \quad (38a)$$

$$\vec{H}(\vec{r}, \nu) = \begin{pmatrix} \vec{H}_1(\vec{r}, \nu) \\ \vec{H}_2(\vec{r}, \nu) \end{pmatrix} \quad (38b)$$

### (III. RADIO ASTRONOMY)

emphasizes that  $\vec{E}$  and  $\vec{H}$  are vectors in the two-dimensional vector space of polarizations, as well as two-dimensional (TEM) vectors in space.

Allowing the constituency relations to be polarization dependent (but not spatially dependent) gives

$$\vec{B}(\vec{r}, \nu) = \underline{\underline{\mu}}(\nu) \vec{H}(\vec{r}, \nu) \quad (39a)$$

$$\vec{D}(\vec{r}, \nu) = \underline{\underline{\epsilon}}(\nu) \vec{E}(\vec{r}, \nu) \quad (39b)$$

$$\vec{J}(\vec{r}, \nu) = \underline{\underline{\sigma}}(\nu) \vec{E}(\vec{r}, \nu) \quad (39c)$$

with  $\vec{B}$ ,  $\vec{H}$ ,  $\vec{D}$ ,  $\vec{E}$ , and  $\vec{J}$  all two-dimensional vectors in the polarization vector space,

$$\underline{\underline{\mu}}(\nu) = \begin{pmatrix} \mu_{11}(\nu) & \mu_{12}(\nu) \\ \mu_{21}(\nu) & \mu_{22}(\nu) \end{pmatrix}; \quad \underline{\underline{\epsilon}}(\nu) = \begin{pmatrix} \epsilon_{11}(\nu) & \epsilon_{12}(\nu) \\ \epsilon_{21}(\nu) & \epsilon_{22}(\nu) \end{pmatrix}; \quad \underline{\underline{\sigma}}(\nu) = \begin{pmatrix} \sigma_{11}(\nu) & \sigma_{12}(\nu) \\ \sigma_{21}(\nu) & \sigma_{22}(\nu) \end{pmatrix}$$

Maxwell's equations become

$$\nabla \times \vec{E}(\vec{r}, \nu) = -i\omega \underline{\underline{\mu}}(\nu) \vec{H}(\vec{r}, \nu) \quad (40a)$$

$$\nabla \times \vec{H}(\vec{r}, \nu) = [\underline{\underline{\sigma}}(\nu) + i\omega \underline{\underline{\epsilon}}(\nu)] \vec{E}(\vec{r}, \nu). \quad (40b)$$

Here,  $\underline{\underline{\sigma}}(\nu)$  and  $\underline{\underline{\epsilon}}(\nu)$  may always be taken as Hermitian. Any complex matrix,  $C$ , has a unique decomposition

$$\underline{\underline{C}} = \underline{\underline{C}}_1 + i\underline{\underline{C}}_2, \quad (41)$$

where both  $\underline{\underline{C}}_1$ , and  $\underline{\underline{C}}_2$  are Hermitian. This is the matrix equivalent to separating a complex number into real and imaginary parts.

If  $\underline{\underline{\mu}}$  and  $\underline{\underline{\epsilon}}$  are independent of polarization, then

$$\underline{\underline{\mu}}(\nu) = \mu_0 \underline{\underline{I}} \quad (42a)$$

$$\underline{\underline{\epsilon}}(\nu) = \epsilon_0 \underline{\underline{I}}. \quad (42b)$$

From Eqs. 40, 42, and the TEM assumption the wave equations follow.

$$\frac{d^2}{dz^2} \vec{E}(\vec{r}, \nu) = i\omega \mu_0 (\underline{\underline{\sigma}}(\nu) + i\omega \epsilon_0 \underline{\underline{I}}) \vec{E}(\vec{r}, \nu) \quad (43a)$$

$$\frac{d^2}{dz^2} \vec{H}(\vec{r}, \nu) = i\omega \mu_0 (\underline{\underline{\sigma}}(\nu) + i\omega \epsilon_0 \underline{\underline{I}}) \vec{H}(\vec{r}, \nu), \quad (43b)$$

where  $z$  is the direction of propagation of the wave.



The solution to (43a) is sought. This is of the form

$$\frac{d^2}{dz^2} \vec{E}(z, \nu) = \underline{\underline{B}}(\nu) \vec{E}(z, \nu) \quad (44a)$$

$$\underline{\underline{B}}(\nu) = -\omega^2 \mu_o \epsilon_o \underline{\underline{I}} + i\omega \mu_o \underline{\underline{\sigma}}(\nu). \quad (44b)$$

Let

$$\underline{\underline{A}}^2(\nu) = \underline{\underline{B}}(\nu). \quad (44c)$$

Then

$$\vec{E}(z, \nu) = e^{-\underline{\underline{A}}(\nu) \Delta z} \vec{E}(z_o, \nu) \quad (45)$$

is a solution to (44a). Hence the task is to find  $\underline{\underline{A}}(\nu)$ . (The same expression with plus sign in the exponential is also a solution, but represents a negative z-traveling wave.)

Decompose  $\underline{\underline{A}}(\nu)$  into its form as in (5):

$$\underline{\underline{A}}(\nu) = \underline{\underline{A}}_1(\nu) + i\underline{\underline{A}}_2(\nu) \quad (46)$$

with  $\underline{\underline{A}}_1(\nu)$  and  $\underline{\underline{A}}_2(\nu)$  Hermitian. Then from (44b) and (44c),

$$\underline{\underline{A}}_2^2 - \underline{\underline{A}}_1^2 = \omega^2 \mu_o \epsilon_o \underline{\underline{I}} \quad (47a)$$

$$\underline{\underline{A}}_1 \underline{\underline{A}}_2 + \underline{\underline{A}}_2 \underline{\underline{A}}_1 = \omega \mu_o \underline{\underline{\sigma}}. \quad (47b)$$

$\underline{\underline{A}}_1(\nu)$  is now seen to be the matrix equivalent to the attenuation constant, and  $\underline{\underline{A}}_2(\nu)$  the matrix equivalent of the propagation constant. The small-loss assumption ( $\text{tr } \underline{\underline{\sigma}}(\nu) \ll \omega \epsilon_o$ ) yields

$$\underline{\underline{A}}_2(\nu) \approx \omega \sqrt{\mu_o \epsilon_o} \underline{\underline{I}} \quad (48a)$$

$$\underline{\underline{A}}_1(\nu) \approx \frac{1}{2} \sqrt{\frac{\mu_o}{\epsilon_o}} \underline{\underline{\sigma}}(\nu). \quad (48b)$$

Equation 48a states that all polarizations have the same propagation velocity; whereas Eq. 48b states that the attenuation (absorption) can be polarization-dependent. Further investigation will also show that

$$|\vec{H}(z, \nu)| = \sqrt{\frac{\epsilon_o}{\mu_o}} |\vec{E}(z, \nu)|, \quad (49)$$

as might be expected.

Note that if N incoherent absorption processes are occurring simultaneously, then

### (III. RADIO ASTRONOMY)

the over-all  $\underline{A}_1(\nu)$  is given by

$$\underline{A}_{1\text{total}}(\nu) = \sum_{n=1}^N \underline{A}_{1n}(\nu), \quad (50)$$

as is seen by looking once again at Maxwell's equations.

Since the  $\underline{A}_{1\text{total}}(\nu)$  is Hermitian, there is a polarization basis in which it is diagonal (no "crosstalk" between polarizations), and experiments can be most readily performed.

W. B. Lenoir

#### References

1. W. B. Davenport and W. L. Root, *Random Signals and Noise* (McGraw-Hill Book Company, New York, 1958).
2. M. Born and E. Wolf, *Principles of Optics* (Pergamon Press, Oxford, 1959).
3. H. C. Ko, On the reception of quasi-monochromatic, partially polarized radio waves, *Proc. IRE* 50, 1950-1957 (1962).
4. S. Chandrasekhar, *Radiative Transfer* (Dover Publications, New York, 1960).

### D. FIVE-MILLIMETER RADIATIVE TRANSFER IN THE UPPER ATMOSPHERE

#### 1. Introduction

The  $O_2$  molecule in the ground state has no electric dipole moment, but does have a magnetic dipole moment resulting from the unpaired spins of two electrons.<sup>1</sup> This magnetic moment permits microwave transitions between the 5 structure levels of the molecular rotational states.

The electron-spin quantum number,  $S$ , is equal to 1 for the  $O_2$  molecule. The total angular momentum quantum number,  $J$ , is given by

$$\begin{aligned} J &= N + 1 \\ J &= N \\ J &= N - 1, \end{aligned} \quad (1)$$

where  $N$ , the rotational quantum number, must be odd because of the exclusion principle. The selection rules permit the transitions

$$J = N \rightarrow J = N + 1,$$

called the  $N^+$  transition, and

$$J = N \rightarrow J = N - 1,$$

called the  $N^-$  transition.

If there is no external magnetic field, the radiation will be isotropic and unpolarized. The introduction of an external magnetic field will greatly complicate the picture by introducing radiation that is neither isotropic nor unpolarized.

## 2. Zeeman Splitting and Matrix Values

The application of an external magnetic field will cause a splitting of the resonance lines because the magnetic moment associated with the  $O_2$  molecule couples with the external field to split the energy associated with a given  $J$  into  $2J + 1$  levels corresponding to  $M = -J, \dots, 0, \dots, J$ , where  $M$  is the quantum number associated with the projection of the  $O_2$  magnetic moment along the direction of the external field. This perturbation<sup>1</sup> is given by

$$\Delta W = -1.001\mu_o MH \frac{J(J+1) + S(S+1) - N(N+1)}{J(J+1)} \quad (2)$$

in which  $\mu_o$  is the Bohr magneton,  $H$  is the external field strength, and  $S = 1$ .

The selection rules permit transitions in  $J$  to be accompanied by changes in  $M$  of  $\Delta M = 0, \pm 1$ . The transition frequencies for the case of no external magnetic field are well known.<sup>2</sup> The change in this frequency,  $\Delta\nu$ , caused by an external magnetic field is given in Table III-4.

Table III-4. Frequency change.

$$\Delta M = M_{\text{final}} - M_{\text{initial}}$$

$$k = 2.8026 \text{ for } \Delta\nu \text{ in Mc/sec}$$

|                 | $J = N \rightarrow J = N + 1$                      | $J = N \rightarrow J = N - 1$                       |
|-----------------|--|---|
| $\Delta M = +1$ | $\frac{kH}{N+1} \left(1 + M \frac{N-1}{N}\right)$  | $-\frac{kH}{N} \left(1 + M \frac{N+2}{N+1}\right)$  |
| $\Delta M = 0$  | $\frac{kH}{N+1} M \frac{N-1}{N}$                   | $-\frac{kH}{N} M \frac{N+2}{N+1}$                   |
| $\Delta M = -1$ | $\frac{kH}{N+1} \left(-1 + M \frac{N-1}{N}\right)$ | $-\frac{kH}{N} \left(-1 + M \frac{N+2}{N+1}\right)$ |

The corresponding matrix elements are readily found by using the tabulated relative intensities<sup>3</sup> and the fact that for  $H = 0$  the total radiation associated with a given transition must be isotropic, unpolarized, and equal in strength to the analysis working directly with the non-Zeeman matrix elements.<sup>1</sup> Table III-5 shows the matrix elements.

(III. RADIO ASTRONOMY)

Table III-5. Matrix elements,  $|\mu|^2$ .

|                 | $J = N \rightarrow J = N + 1$                                 | $J = N \rightarrow J = N - 1$                             |
|-----------------|---|---|
| $\Delta M = +1$ | $\frac{3}{2} \frac{N(N+M+1)(N+M+2)}{(N+1)^2 (2N+1)} \mu_0^2$  | $\frac{3}{2} \frac{(N+1)(N-M)(N-M-1)}{N^2(2N+1)} \mu_0^2$ |
| $\Delta M = 0$  | $\frac{3}{2} \frac{N[(N+1)^2 - M^2]}{(N+1)^2 (2N+1)} \mu_0^2$ | $\frac{3}{2} \frac{(N+1)(N^2 - M^2)}{N^2(2N+1)} \mu_0^2$  |
| $\Delta M = -1$ | $\frac{3}{2} \frac{N(N-M+1)(N-M+2)}{(N+1)^2 (2N+1)} \mu_0^2$  | $\frac{3}{2} \frac{(N+1)(N+M)(N+M-1)}{N^2(2N+1)} \mu_0^2$ |

3. Complex Propagation Matrix

In this situation the velocity of propagation is independent of polarization. Furthermore, for brightness-temperature coherency spectrum matrix calculations the only part of  $\underline{\underline{A}}(\nu)$  that matters is its Hermitian part, since the anti-Hermitian part (i times a Hermitian matrix) is a constant times the unit matrix, and this will not appear in the matrix solution (see Secs. III-B and III-C).

For a given J transition ( $J=N \rightarrow J=N \pm 1$ ) there are three unrelated processes, those for  $\Delta M = 0$ ,  $\Delta M = +1$ ,  $\Delta M = -1$ . Hence the  $\underline{\underline{A}}_{\text{total}}(\nu)$  will be the sum of the individual  $\underline{\underline{A}}(\nu)$ . The radiation emitted from any one of these processes is totally polarized.<sup>3</sup> The type of polarization depends on the direction of observation (that is, on the angle between the external field and the observing direction).

Since the radiation from one process is totally polarized, the medium will be transparent to the opposite polarization. On this polarization basis

$$\underline{\underline{A}}_{\Delta M}(\nu) = \begin{pmatrix} a_{\Delta M}(\nu) & 0 \\ 0 & 0 \end{pmatrix} \quad (3)$$

in which  $\underline{\underline{A}}_2(\nu)$  has been neglected. This polarization basis will be different for each of the processes ( $\Delta M=0, \pm 1$ ). On this basis, it is easy to discuss an experiment to measure  $\underline{\underline{A}}_{\Delta M}(\nu)$ , inasmuch as it is now a scalar problem.

The  $\underline{\underline{A}}_{\Delta M}(\nu)$  obtained can be transformed to a common basis and summed.

$$\underline{\underline{A}}(\nu) = \underline{\underline{A}}_{\Delta M=+1}(\nu) + \underline{\underline{A}}_{\Delta M=0}(\nu) + \underline{\underline{A}}_{\Delta M=-1}(\nu), \quad (4)$$

where the  $\underline{\underline{A}}_{\Delta M}(\nu)$  must all be on the same basis.

The chosen standard basis is convenient for the problem of the reception of microwave radiation from the atmosphere by an earth-orbiting satellite. Let  $R, \theta, \phi$  be the normal spherical coordinates (center of earth as origin, north rotation axis as +z) of

the observation point. The direction of observation is in the  $-\vec{L}_R$  direction. Let the polarization basis be

$\alpha$ , linear polarization in  $\vec{L}_\theta$  direction.

$\beta$ , linear polarization in  $\vec{L}_\phi$  direction.

The magnetic North Pole and the rotational North Pole do not coincide. Hence, there will in general be a  $\phi$  component of the magnetic field which would not be as it is if the two poles coincided.

At a given point along the observational path,  $r, \theta, \phi$  with  $r \leq R$ , let the angle between  $B$ , the magnetic field, and  $R$  define  $\psi_{BP}$ ;  $\psi_{BP} \in [0, \pi]$ . Also, let the angle between the projections of  $B$  and  $\vec{L}_z$  on a plane perpendicular to  $R$  define  $\psi_{BN}$ ;  $\psi_{BN} \in [-\pi, \pi]$ .  $\psi_{BN}$  is a consequence of the two poles not coinciding.

In this coordinate system each of the  $\underline{\underline{A}}_{\Delta M}(\nu)$  will be of the form

$$\begin{pmatrix} \rho_{11}(\nu) & \rho_{12_R}(\nu) + i\rho_{12_I}(\nu) \\ \rho_{12_R}(\nu) - i\rho_{12_I}(\nu) & \rho_{22}(\nu) \end{pmatrix} \quad (5)$$

with the 1 coordinate being the  $\theta$ -directed linear polarization (for  $\vec{e}_\theta$ ), and 2 being the  $\phi$ -directed linear polarization.

The  $\underline{\underline{A}}_{\Delta M}(\nu)$  for one process<sup>2,4</sup> is given by

$$\underline{\underline{A}}_{\Delta M}(\nu) = c \frac{p\nu^2}{T^3} e^{-E_J/T} \underline{\underline{\rho}}_{\Delta M} \sum_{M=-J}^J |\mu_{J, \Delta M}|^2 F(\nu, \nu_{J, \Delta M}, \Delta\nu_d, \Delta\nu_c), \quad (6)$$

in which

$p$  = pressure in mm Hg

$T$  = temperature in degrees Kelvin

$\nu$  = frequency in Gc/sec

$E_J$  = energy of  $J^{\text{th}}$  level in degrees Kelvin

$|\mu|^2$  = matrix elements listed above

$c = 0.30506$ , a constant for  $\underline{\underline{A}}$  having units of  $\text{km}^{-1}$ .

$F(\nu, \nu_{J, \Delta M}, \Delta\nu_d, \Delta\nu_c)$  is the convolution of the pressure-broadening (Lorentz) shape with the Doppler (gauss) shape for  $\Delta\nu_d$  = Doppler half-width,  $\Delta\nu_c$  = collision half-width, and  $\nu_{J, \Delta M}$  = split resonant-frequency component.

$\underline{\underline{\rho}}_{\Delta M}$  is a Hermitian matrix describing the angular ( $\psi_{BP}$  and  $\psi_{BN}$ ) dependence of polarization. It is of the form

$$\underline{\underline{\rho}}_{\Delta M} = \begin{pmatrix} \rho_{11} & \rho_{12_R} + i\rho_{12_I} \\ \rho_{12_R} - i\rho_{12_I} & \rho_{22} \end{pmatrix}. \quad (7)$$

### (III. RADIO ASTRONOMY)

For  $\Delta M = 0$ ,

$$\begin{aligned}
 \rho_{11} &= \sin^2 \psi_{BP} \sin^2 \psi_{BN} \\
 \rho_{12_R} &= \sin^2 \psi_{BP} \sin \psi_{BN} \cos \psi_{BN} \\
 \rho_{12_I} &= 0 \\
 \rho_{22} &= \sin^2 \psi_{BP} \cos^2 \psi_{BN}.
 \end{aligned} \tag{8}$$

For  $\Delta M = \pm 1$ ,

$$\begin{aligned}
 \rho_{11} &= \frac{1}{2} \left[ \cos^2 \psi_{BN} + \sin^2 \psi_{BN} \cos^2 \psi_{BP} \right] \\
 \rho_{12_R} &= -\frac{1}{2} \sin^2 \psi_{BP} \sin \psi_{BN} \cos \psi_{BN} \\
 \rho_{12_I} &= \mp \frac{1}{2} \cos \psi_{BP} \\
 \rho_{22} &= \frac{1}{2} \left[ \sin^2 \psi_{BN} + \cos^2 \psi_{BN} \cos^2 \psi_{BP} \right].
 \end{aligned} \tag{9}$$

The complex propagation constant is completed by summing over the possible J transitions.

#### 4. Radiative Transfer Solution

The problem is to solve

$$\frac{d}{dz} \underline{\underline{T}}_B(\nu) + \underline{\underline{A}}(\nu) \underline{\underline{T}}_B(\nu) + \underline{\underline{T}}_B(\nu) \underline{\underline{A}}^{t*}(\nu) = 2t_k \underline{\underline{A}}(\nu), \tag{10}$$

where  $t_k$  is the atmospheric kinetic temperature (a function of  $z$ ), and the Hermitian nature of  $\underline{\underline{A}}(\nu)$  has been used. The method is to approximate the atmosphere as a series of constant-temperature, constant-pressure layers, each 1 km thick, extending from the ground to a height of 100 km.

The solution to Eq. 10 for the transfer through one such layer is

$$\underline{\underline{T}}_{B_0}(\nu) = e^{-\underline{\underline{A}}(\nu) \Delta z} \underline{\underline{T}}_{B_i}(\nu) e^{-\underline{\underline{A}}(\nu) \Delta z} + t_k [\underline{\underline{I}} - e^{-2\underline{\underline{A}}(\nu) \Delta z}], \tag{11}$$

where  $\underline{\underline{T}}_{B_i}(\nu)$  is the brightness-temperature coherency spectrum matrix incident on the layer,  $t_k$  is the temperature of the layer, and  $\underline{\underline{A}}(\nu)$  is the complex propagation

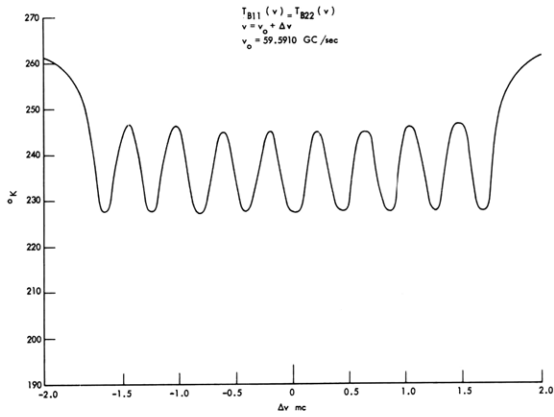

Fig. III-7.  $J = 5 \rightarrow J = 4$  transition (magnetic pole).

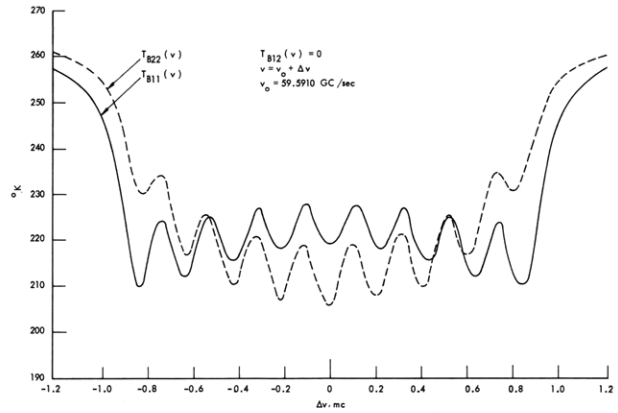

Fig. III-9.  $J = 5 \rightarrow J = 4$  transition (magnetic equator).

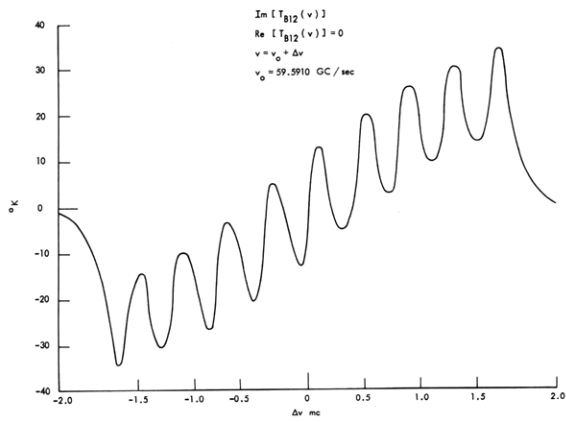

Fig. III-8.  $J = 5 \rightarrow J = 4$  transition (magnetic pole).

(III. RADIO ASTRONOMY)

matrix of the layer.

Continued application of Eq. 11 yields the  $\underline{\underline{T}}_B(\nu)$  as received at the satellite. A slightly different analysis emphasizing the contribution to  $\underline{\underline{T}}_B(\nu)$  from the various heights would involve the matrix weighting functions. In this procedure the emission from one layer is treated from emission height to satellite. Each height is treated accordingly, and the results summed.

The weighting function matrix is found to be

$$\underline{\underline{WF}}(h_i, \nu) = \underline{\underline{P}}(h_i, \nu) \left[ I - e^{-2\underline{\underline{A}}(\nu, h_i) \Delta h_i} \right] \underline{\underline{P}}^{t*}(h_i, \nu) \quad (12)$$

with

$$\underline{\underline{P}}(h_i, \nu) = e^{-\underline{\underline{A}}(\nu, h_s) \Delta h_s} e^{-\underline{\underline{A}}(\nu, h_{s-1}) \Delta h_{s-1}} \dots e^{-\underline{\underline{A}}(\nu, h_{i+1}) \Delta h_{i+1}}. \quad (13)$$

The  $\underline{\underline{T}}_B(\nu)$  is obtained from (12) by

$$\underline{\underline{T}}_B(\nu) = \sum_{h_i=\text{ground}}^{\text{satellite}} \underline{\underline{WF}}(h_i, \nu) t(h_i). \quad (14)$$

Examples of the  $\underline{\underline{T}}_B(\nu)$  computed for two resonance lines at positions corresponding to both the magnetic pole and the magnetic equator are presented in Figs. III-7, III-8, and III-9.

A particular point on the magnetic equator was chosen so that  $T_{B12}(\nu) = 0$ . The fine structure resulting from the individual Zeeman components is easily seen. A dipole model of the earth's magnetic field was used, with  $|B| = 0.624$  gauss at the pole.

W. B. Lenoir

References

1. C. H. Townes and A. L. Schawlow, Microwave Spectroscopy (McGraw-Hill Book Company, New York, 1955).
2. M. L. Meeks and A. E. Lilley, The microwave spectrum of oxygen in the Earth's atmosphere, J. Geophys. Res. 68, 1683-1703 (1963).
3. E. U. Condon and G. H. Shortley, The Theory of Atomic Spectra (Cambridge University Press, London, 1951).
4. J. H. VanVleck and V. F. Weisskopf, On the shape of collision-broadened lines, Rev. Modern Phys. 17, 3 (1945).