



EXPERIENCE WITH CONTROL OF FREQUENCY, AMPLITUDE AND PHASE

H.-D. GRÄF*

*Institut für Kernphysik, Technische Hochschule Darmstadt, Schlossgartenstr. 9, D-6100
Darmstadt, Germany*

Control systems for frequency, amplitude, and phase in superconducting accelerator cavities have the same task as in normal conducting accelerators, they stabilize the accelerating field in order to obtain a narrow energy spread of the output beam. However due to their very narrow bandwidth superconducting cavities are much more sensitive to external perturbations than normal conducting accelerating structures. Therefore typical perturbations like microphonics and radiation pressure are discussed and their influences on the superconducting cavities are described. The two basic principles of rf control systems presently used in superconducting electron accelerators are introduced and a compilation of the operational experience from different institutions is presented and discussed.

KEY WORDS: Superconducting RF systems, linear accelerators, storage rings

1 INTRODUCTION

Following the example of the superconducting (sc) electron accelerator at the High Energy Physics Laboratory (HEPL)¹ at Stanford, Cal., USA and the microtron MUSL-II² at the University of Illinois at Champaign-Urbana, Ill., USA, several electron accelerators using sc cavities have come into operation or have made major steps towards final commissioning during the last few years. In storage rings at KEK^{3,4}, Tsukuba, Japan, 32 sc cavities have been in operation in the TRISTAN ring since 1989, at CERN, Geneva, Switzerland, 12 sc cavities have been installed and operated in LEP^{5,6}, and at DESY, Hamburg, Germany, 12 sc cavities have been operated successfully in the electron ring of HERA^{7,8,9} since spring 1991. In linear accelerators and recirculating linacs the S-DALINAC^{10,11} at Darmstadt, Germany, became fully operational including two recirculations in December 1990, CEBAF¹² at Newport News, VA., USA, achieved a 45 MeV front end test in spring of 1991 and MACSE¹³, the test facility for future sc electron linacs at Saclay, France, performed first successful tests in 1991. Even though this article deals almost exclusively with the rf operation of sc electron accelerators it has to be noted that there is a whole landscape of working sc heavy ion accelerators¹⁴ including the pioneering installations at ANL¹⁵, Argonne, Ill., USA, at BNL¹⁶, Brookhaven, NY., USA, and at Saclay¹⁷, France.

* Supported by Bundesministerium für Forschung und Technologie under contract numbers 06 DA 184 I and 05 345 EA I 3.

As in any accelerator it is the main task of the rf control system to stabilize amplitude and phase of the accelerating field in the cavities. The level to which this stabilization can be achieved determines the energy spread of the produced particle beam, even though the influence is quite different depending on the type of accelerator (linac, recirculating linac, or circular accelerator). For the rf operation sc accelerating structures (hence referred to as cavities), present a significantly different problem as compared with cavities operating at room temperature. Normal conducting (nc) cavities in linacs have an unloaded quality factor Q_o on the order of 10^4 and are usually composed of a fairly large number of cells so that the individual modes of the accelerating (TM_{010}) passband are overlapping. Due to the dissipation of several kW/m of rf power detuning associated with temperature gradients can represent a problem for the rf operation. On the other hand nc cavities are almost insensitive to microphonics (mechanical vibrations influencing the eigenfrequency of the cavity) due to their very rigid mechanical construction and their wide bandwidth.

SC cavities usually have a Q_o well in excess of 10^9 and even though they usually have to be operated strongly overcoupled (due to the optimization of energy transfer to the beam) their loaded quality factor Q_L is in the range of several 10^6 . Since sc cavities usually have a small number of cells the accelerating mode (the π mode of the TM_{010} passband) appears as a single, well isolated resonance for the rf operation. Due to the low dissipation of rf power (mostly less than 100 W/m at gradients below 10 MV/m) temperature gradients do not represent a problem, microphonic perturbations of the cavity however play a very important role, in particular since sc cavities are composed of rather thin walled cells (fabricated either by deep drawing or spinning of sheet material or by hydroforming) and have much less rigidity than nc copper cavities. Therefore perturbations of the cavity will be discussed in Sect.2 whereas the principal properties of rf control systems for the stabilization of amplitude and phase will be introduced in Sect.3. Experience from different systems presently in use at sc accelerators is compiled and discussed in Sect.4. Finally in Sect.5 an attempt is made to draw some conclusions from operational experience presently available for possible future sc accelerator projects.

2 PERTURBATIONS OF THE CAVITY

There are many mechanisms which will influence the magnitude and/or the phase of the accelerating field in a superconducting cavity.

2.1 Load conditions

Varying load conditions like e.g. caused by a varying beam current require that always the correct amount of rf power is fed into the cavity as to keep the field constant. In almost any case sc cavities are extremely heavily beam loaded and therefore particularly sensitive to a varying beam current. Additional losses due to e.g. multipacting or electron emission cause fluctuations of both amplitude and phase of the accelerating field. These influences can be controlled if the reaction speed of the rf control system together with the sc cavity is fast enough. If this is not the case the mechanisms form a limitation to the cavity performance unless they can be overcome by other means.

2.2 Higher order modes

The excitation of higher order modes (HOM) by the beam also represents a perturbation of the field distribution of the accelerating mode. It is however not controlled by the rf system. It is the art of building cavities of optimized shapes and of developing special couplers for the extraction of HOM power which keeps the excitation of HOM's at the lowest possible level.

2.3 Microphonics

Mechanical changes of the shape and eigenfrequency of the sc cavities caused by microphonics are a source of amplitude and phase jitter which has bothered sc accelerator technology throughout its development (for a comprehensive compilation of references see¹⁸). In general sc cavities for heavy ion accelerators are more sensitive to microphonics than cavities for electron accelerators. However, the fact that niobium becomes softer with increasing purity together with the little rigidity of present days sc cavities, makes them sensitive enough to require a sophisticated rf control system if an amplitude stability of less than 10^{-3} and a phase stability of better than 1° have to be achieved.

Some possible sources and the way how they usually interact are shown in Fig. 1 in a symbolic way. Heavy machinery can transmit vibrations through the ground, supports, and the cryostat to the cavity. Vacuum pumps can interact with the cavity through the beam tubes and the compressors and pumps of the refrigerator will generate mechanical vibrations which travel along the pipes and heat exchangers of the refrigerator and the He transfer line into the cryostat until they reach the cavity. Also pressure variations in the gaseous helium generated by this machinery can, under unfavourable circumstances, interact with the cavity, sometimes even boiling helium can be too noisy. In all of these cases there is a source which generates a spectrum of noise which passes through a transfer medium (which has certain filter characteristics) and interacts with the cavity which together with its tuner and fixture in the cryostat responds with its own characteristic to the external perturbations. The observed amplitude and phase jitter is the superposition of all of these influences and in general it is very difficult and cumbersome (if not impossible) to analyze, unless there is a source which has a clear and distinct 'fingerprint' in its frequency spectrum.

2.4 Radiation pressure

With increasing accelerating gradients the influence of radiation pressure (the interaction of the cavity with its own electromagnetic field) becomes an important effect. The pressure on the inner surface of the cavity is given by

$$P_{rad} = \frac{1}{2} (\mu_0 H^2 - \epsilon_0 E^2) \quad (1)$$

where ϵ_0 and μ_0 are the permittivity and permeability constants of the vacuum. The electric field E results in an attractive force whereas the magnetic field H acts repulsively onto the surface. In general this 'pressure' causes a small deformation of the cavity shape

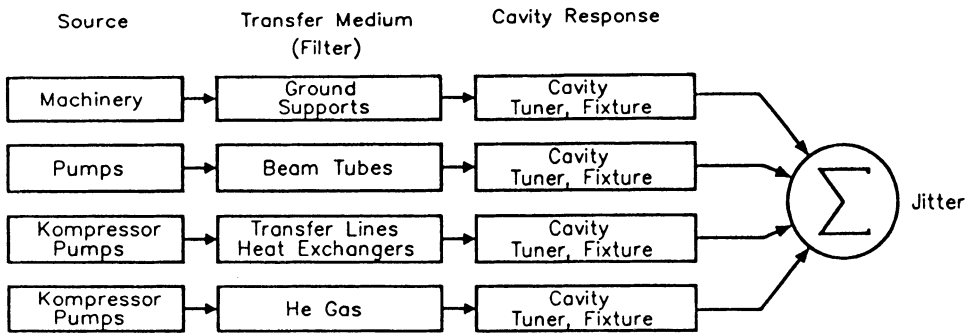

FIGURE 1: Schematic diagram of the influence of microphonics

which results in a shift Δf of its eigenfrequency, Δf being proportional to the square of the accelerating gradient

$$\Delta f = k \cdot E_{acc}^2. \quad (2)$$

The constant k which describes the reaction of the cavity is a function of cavity shape, wall thickness, yield strength of the material, and the mechanical properties of the cavity fixture inside the cryostat as well as the field distribution of the cavity.

A calculation of such a deformed resonance for a 20-cell cavity operating at 3 GHz is shown in Fig. 2. For k a value of $-4 \text{ Hz}/(\text{MV}/\text{m})^2$ has been used as observed for the cavities of the S-DALINAC made from RRR = 280 niobium. For a gradient of 5 MV/m a shift of the eigenfrequency by $\Delta f = -100 \text{ Hz}$ is expected. The circles represent a measurement on one of the S-DALINAC cavities being excited by constant power yielding a maximum gradient of 4.3 MV/m. The measurement clearly shows that the effect of detuning due to radiation pressure is clearly observable not only in 'soft' cavities as being used in sc heavy ion accelerators but also in sc cavities used in electron accelerators. Experimental values for k have also been measured at the accelerator facilities at CEBAF where $k = -3 \text{ Hz}/(\text{MV}/\text{m})^2$ has been determined for a 5-cell cavity at 1500 MHz and at Saclay where a similar cavity also showed a detuning of $k = -3 \text{ Hz}/(\text{MV}/\text{m})^2$ being mounted in a tuner whereas k amounted to $-10 \text{ Hz}/(\text{MV}/\text{m})^2$ for a cavity without tuner in a test cryostat.

For the rf operation of sc cavities detuning by radiation pressure introduces two instabilities: on the right slope of the deformed resonance an exchange of energy between the electromagnetic field in the cavity and mechanical deformations of the cavity can occur causing ponderomotive oscillations of the gradient whereas on the left slope a static instability exists limiting the operating range of the rf control systems. Both effects have been studied extensively and it could be shown¹⁹ that these instabilities can be suppressed to some extent by the rf control system allowing the sc cavity to be operated at higher gradients. However, the effect of radiation pressure due to its dependence on E_{acc}^2 becomes extremely important at very high gradients. For the purpose of demonstration Fig. 3 shows the resonance curve of Fig. 2 extended to $E_{acc} = 25 \text{ MV}/\text{m}$ (the dashed line indicates how the maximum of the resonance shifts as the cavity field is increased).

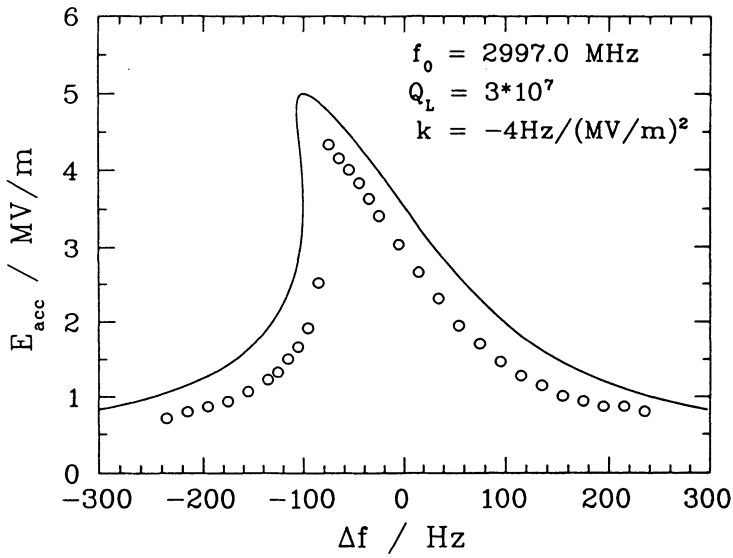

FIGURE 2: Influence of radiation pressure on the resonance of a sc cavity. Open circles represent a measurement on one of the S-DALINAC cavities.

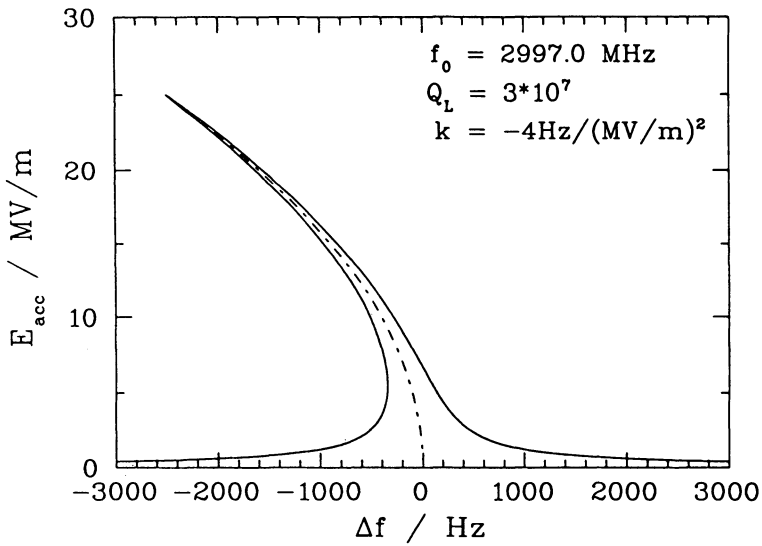

FIGURE 3: Detuning due to radiation pressure at a gradient of 25 MV/m. The dashed-dotted line indicates the shift of the cavity eigenfrequency as a function of the gradient.

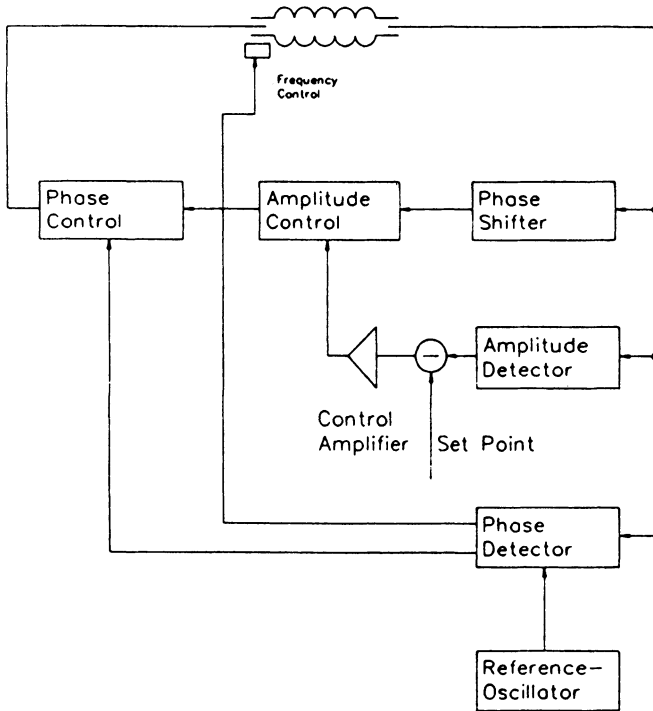

FIGURE 4: Simplified functional diagram of a 'driven' rf control system.

The detuning in this case amounts to 25 bandwidths of the cavity and it is obvious that either the bandwidth or the mechanical rigidity of the cavity has to be increased in order to allow a stable operation with amplitude and phase well controlled.

3 RF-CONTROL SYSTEM

Presently two types of rf control systems are used in accelerators using sc cavities, 'driven' systems where a signal from a reference source is manipulated and amplified to drive the cavity and systems using a self excited loop which is phaselocked to an external reference source.

The basic functions of a 'driven' system are shown in Fig. 4. The signal from a reference oscillator passes through a phase shifter, which determines the reference phase for the particular cavity. The signal is then processed by phase- and amplitude controllers and after final amplification (not shown in Fig. 4) drives the cavity. For amplitude control a probe signal from the cavity is taken to an amplitude detector, its output is compared with the set point and the error signal after amplification and filtering drives the amplitude control unit. The phase of the probe signal is compared with the reference signal and errors detected are corrected by the phase control unit. The frequency control unit also shown in Fig. 4 assures that eigenfrequency of the cavity and operating frequency of the accelerator are identical. In Fig. 5 a simplified diagram of a system using a self excited loop is shown.

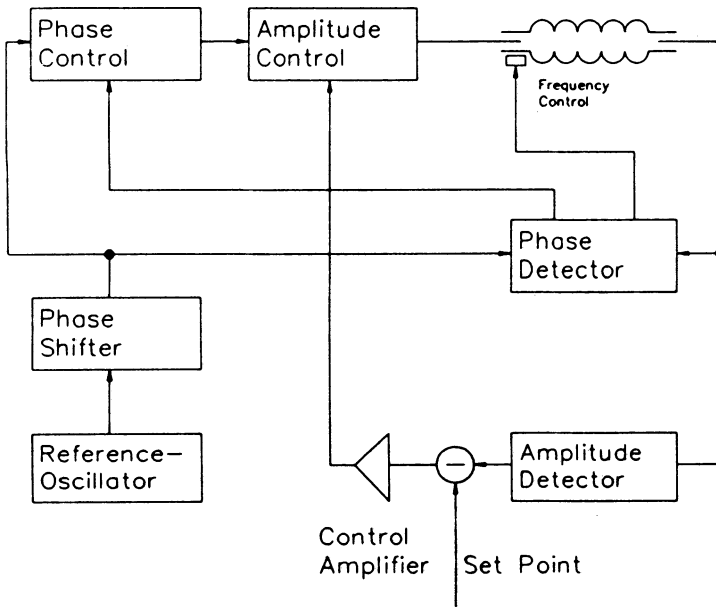

FIGURE 5: Simplified functional diagram of an rf control system using a self excited loop.

A probe signal from the cavity passes through a loop phase shifter, amplitude- and phase controllers, and after final amplification (not shown in Fig. 5) drives the cavity, closing the self excited loop. This circuit oscillates under the condition that the total gain in the loop amounts to one and that the total phase shift along the loop is an integer multiple of 2π . The condition for the gain is fulfilled by the amplitude control circuit where the amplitude of the probe signal is detected and compared with the set point. The error signal is amplified and filtered and drives the amplitude control keeping the loop gain equal to one and a field level corresponding to the set point. The sc cavity being the most narrowbanded element in the loop determines the frequency at which the circuit oscillates and a proper setting of the loop phase shifter assures that it agrees with the eigenfrequency of the cavity. Phaselock to an external reference is achieved by phase comparison of the probe signal with the reference signal through the phase control unit which actually produces a frequency shift of the self excited loop to correct the phase. As with the 'driven' system the frequency control unit keeps the eigenfrequency of the cavity identical with the operating frequency of the accelerator.

These frequency control devices commonly referred to as tuners play an important role in all of the existing accelerators using sc cavities. They serve three different purposes:

- They have to ensure that after installation in the cryostat and cooldown the cavity eigenfrequency matches the operating frequency of the accelerator. This means that

their range is determined by the predictability of the cavity eigenfrequency at low temperatures and by the reproducibility of the installation.

- During operation tuners have to correct slow changes (drifts) of the cavity eigenfrequency to allow the cavity to be operated on resonance. The correction speed of a mechanical tuner is however limited by the mechanical resonances of the cavity–tuner–system lowest in frequency.
- Tuners have to correct for detuning due to radiation pressure to allow a cavity to be operated at different field levels.

As a conclusion tuners should be an active part of the rf control system in order to achieve a comfortable and stable operation of the cavities. In most cases tuners are composed of two parts: for coarse tuning devices driven by electromotors, hydraulics, or by thermal expansion are used whereas fine tuning is either accomplished by piezoelectric or magnetostrictive translators or by an external electronically variable reactance (VCX) as it is the case in some heavy ion accelerators.

Since the reaction speed of mechanical tuners is limited (see above) and usually slower than perturbations of the cavity eigenfrequency introduced by microphonics, a jitter of the cavity eigenfrequency about the operating frequency has to be accepted. It is the task of the rf control system to keep the amplitude and phase of the cavity stable by electronic means despite of this jitter. If a resonator is operated off resonance the magnitudes of its amplitude and phase deviations are correlated and depend on its loaded Q and the magnitude Δf of the frequency deviation. In a complex representation the cavity field V as a function of Q_L and Δf is given by

$$V = V_o / (1 + j \cdot 2Q_L \Delta f) = V_o / (1 + j \cdot \tan \Delta \varphi) \quad (3)$$

and the amplitude- and phase deviations amount to

$$|\Delta V| = V_o - |V| \quad (4)$$

and

$$\Delta \varphi = \tan^{-1} 2Q_L \Delta f, \quad (5)$$

respectively. In order to keep V equal to V_o the following corrections on V have to be applied

$$V_o = V \cdot e^{j\Delta\varphi} / \cos \Delta\varphi \quad (6)$$

where the first correction corresponds to the action of a phase shifter whereas the second correction requires the action of an amplitude modulator. Thus the control circuits for amplitude and phase are coupled. Rewriting equ.(6) as

$$V_o = V \cdot (1 + j \cdot \tan \Delta \varphi) \quad (7)$$

however shows that adding a voltage proportional to $\Delta \varphi$ in quadrature, as it can be achieved by a complex phasor modulator (CPM) is the only correction needed; thus decouples the amplitude- and phase control units. Thus the use of a CPM instead of a phase shifter is highly recommendable if the frequency deviations to be controlled amount to a sizeable fraction of the loaded bandwidth.

4 PERFORMANCE OF SYSTEMS IN OPERATION

Presently almost any accelerator facility has developed its own rf control system tailored to its specific needs. Heavy ion accelerators usually use a system based on a self excited loop because their sc cavities are more sensitive to microphonics and radiation pressure than cavities for electron accelerators. All of the sc electron accelerators use a 'driven' system of different sophistication, except of the S-DALINAC where a self excited loop system was developed allowing to control the rather heavy microphonic perturbations from the helium refrigerator equipment.

A compilation of data characterizing the performance of rf control systems operating in sc electron accelerators is given in Table 1 for storage rings and in Table 2 for linacs and recirculating linacs. At a first glance the amount of data might be confusing but a closer look shows certain systematics. All storage ring cavities operate at rather low frequencies (352 – 508 MHz) and have 4 or 5 cells per cavity. They have an unloaded Q of $1 - 3 \cdot 10^9$ and are loaded rather heavily due to the high beam current in storage rings. Several cavities are driven from a common power source except for the CERN/SPS case where a system using direct rf feedback²⁰ was used to drive sc cavities being installed in the SPS for test purposes. Long time operational experience is available there as it is the case for the cavities installed in the TRISTAN storage ring at KEK. There the rf control system²¹ uses the vectorial sum of the probe signals from the four cavities being powered by the same klystron. In addition an internal stabilization loop is used to compensate phase deviations occurring across the 1 MW klystron. CERN and DESY presently operate systems less sophisticated, not using the vectorial sum of probe signals from different cavities.

The sensitivity of the cavities towards external perturbations are similar. A length variation produces a frequency shift of 40-80 kHz/ μ m whereas pressure sensitivities range from 8 to 80 Hz/mbar, the difference probably being due to the slightly different cavity shapes and to the different ways the cavities are mounted inside the cryostats. No information was available on detuning due to radiation pressure. Predictability of the cavity eigenfrequency apparently is on the order of 100 kHz and the reproducibility after an intermediate warmup amounts to a few kHz. All storage ring cavities are equipped with tuners which change the length of the cavity and in all cases the tuners are an active part of the rf control system. The performance of the different systems show that an amplitude stability of 1–2% and a phase stability of a few degrees is being achieved when several cavities are driven from a common power source. If, as in the CERN/SPS case, the cavity has its own power source and a specially tailored control system much better stabilities can be achieved. As one would expect dominant perturbations have rather low frequencies and originate from different sources.

In sc electron linacs a wider variety of cavities is in operation; frequencies range from 1.3 to 3 GHz and the number of cells per cavity differs significantly. The loaded Q varies within one order of magnitude due to the different beam loading and the power sources available. In all installations each cavity has its individual klystron and rf control system. HEPL being operated for a long time has the longest operational experience followed by the S-DALINAC, whereas CEBAF and MACSE have started to operate in spring of 1991.

TABLE 1: Performance of sc cavities in electron storage rings

Institution	KEK	CERN/LEP	DESY	CERN/SPS
Cavities	(16+16)Nb	4Nb+8Nb/Cu	12 Nb	1 Nb
Cells	5	4	4	4
Frequency (MHz)	508	352	500	352
$Q_o(10^9)/Q_L(10^6)$	2/1	2-3/2-3	1/0.24	3/n.a.
Gradient (MV/m)	3.5 – 4	3.7	3.5	5
Transmitters ¹⁾	K 1 MW	K 1 MW	K 1 MW	T 50 kW
Cav./Transm.	4	16	16	1
Oper. Time (h)	$10^4/7 \cdot 10^3$	a few 10^2	a few 10^2	$2.3 \cdot 10^4$
Mech. Sens. (Hz/ μ m)	80	40	80	≈ 40
Press. Sens. (Hz/mbar)	30	8	80	8
Gradient Sens. (Hz/(MV/m) ²)				
Freq. pred. (kHz)	± 100		± 90	
Freq. repr. (kHz)			a few	
Tuning Princ. ²⁾	LV	LV	LV	LV
Tuner ³⁾	SM + PE	TE + M	SM	TE + M
Freq. range coarse(kHz)	350	50	800	50
Freq. range fine (Hz)	6000	2000		2000
Autom. Contr.	yes	yes	yes	yes
Ampl. Stab.	$< \pm 1\%$	1.5% pp		$< 10^{-4}$
Phase Stab.	$< \pm 5^\circ$	a few $^\circ$		$< 1^\circ$
To be contr.	$\pm 45^\circ$			
Perturbations	LHe flow, Cavity res.	pressure oscillations		LHe evaporation
Dom. freq. (Hz)	50			51,63,73

1) K = Klystron, T = Tetrode

2) LV = length variation

3) SM = stepping motor, TE = thermal expansion

PE = piezoelectric, M = magnetostrictive

TABLE 2: Performance of sc cavities in electron linacs

Institution	HEPL	S-DALINAC	CEBAF	MACSE
Cavities	7 Nb	(10+1) Nb	18 Nb	(4+1) Nb
Cells	7/23/55	20/5	5	5/3
Frequency (MHz)	1300	2997	1497	1497
$Q_o(10^9)/Q_L(10^6)$	2/4	1-2/30	6/6	5/5
Gradient (MV/m)	> 3/2.5	5.6	5	4 – 5
Transmitters ¹⁾	K 10 kW	K 0.5 kW	K >5 kW	K 5 kW
Cav./Transm.	1	1	1	1
Oper. Time (h)	$3 \cdot 10^4$	$3.5 \cdot 10^3$	a few 10^2	$\approx 10^2$
Mech. Sens. (Hz/ μm)	n. a.	500	500	500
Press. Sens. (Hz/mbar)		-15	-60 (10)	-60
Gradient Sens. (Hz/(MV/m) ²)		-4	-3	-3
Freq. pred. (kHz)	13	± 200	<20	< ± 50
Freq. repr. (kHz)	<1	± 20	$\ll 20$	< ± 25
Tuning Princ. ²⁾	P	LV	LV	LV
Tuner ³⁾	SM	DCM + M	SM	SM + M
Freq. range coarse(kHz)	25	1000	400	1500
Freq. range fine (Hz)		1500		
Autom. Contr.	no	yes	yes	yes
Ampl. Stab.	$\pm 3 \cdot 10^{-5}$	$\pm 1.5 \cdot 10^{-3}$	$\leq 10^{-4}$	(10^{-4})
Phase Stab.	$\ll 1^\circ$	$\pm 0.3^\circ$	$\pm 0.15^\circ$	(0.1°)
To be contr.		10 – 60°	5-20°(80°)	
Perturbations ⁴⁾		Compressor Transfer line	Compressor Cavity res.	TAO
Dom. freq. (Hz)				65

1) K = Klystron

2) P = plunger, LV = length variation

3) SM = stepping motor, DCM = DC-motor
M = magnetostrictive

4) TAO = thermo-acoustic oscillations

The sensitivity of the cavities toward external influence reveal a very interesting result: The sensitivity of the HEPL cavities to a pressure change and to radiation pressure apparently is so low that it was never recognized as being a problem and therefore no figure could be provided. Since the cavities have stiffening bars welded to each cell at the equator keeping the total length constant (except for the outer halves of the end cells) a figure for the mechanical sensitivity (frequency shift due to a uniform length change) is not applicable. Also predictability and reproducibility of the cavity eigenfrequencies is outstanding. The cavities at the other installations are fabricated from niobium of reduced yield strength (due to higher purity), they have a reduced wall thickness and they have no stiffening bars. Therefore they show comparable sensitivities, the figures from the S-DALINAC cavities being somewhat higher due to the high operating frequency, and due to the fact that a 20-cell cavity is more sensitive to mechanical deformations than a 5-cell cavity.

Darmstadt, CEBAF and Saclay use tuners which change the length of the cavity and the tuners are operated by the rf control system, whereas HEPL because of the cavity lengths being fixed by the stiffening bars uses a plunger tuner.

The performance of the rf control systems is remarkable. Fractions of a degree in phase stability and amplitude stabilities of 10^{-4} are achieved (the reduced amplitude stability of the S-DALINAC is due to some imperfections in the microwave components being presently used) even though severe jitter of the cavity eigenfrequencies (expressed as phase jitter in Table 2) have to be controlled. Common sources are microphonics introduced by the refrigerator equipment in combination with mechanical resonances of the cavities forming a rather broadband perturbation spectrum. At Saclay in the beginning of the operation a thermo-acoustic oscillation at a very distinct frequency has been observed.

As a summary of this section it appears that individual rf control systems for each cavity presently provide much better stabilities (one order of magnitude in phase stability and two orders of magnitude in amplitude stability) than systems where several cavities share one common transmitter and a single control system. It should be recognized that CEBAF presently has developed the most sophisticated rf control system, using a heterodyne principle and having incorporated numerous interlock functions due to the large number of cavities to be controlled in the final installation.

5 CONCLUSIONS

It is certainly difficult to conclude on the extremely wide variety of rf control systems presently being in operation at the different sc accelerators, however the fact that these accelerators work shows that everywhere a solution to the problem of rf control was found. Therefore with respect to possible future installations of sc accelerators which ask for high gradients, a large number of cavities, and for cost effectiveness a few statements seem to be appropriate.

- A reduced sensitivity of the cavities with respect to microphonics can reduce the rf power needed and will simultaneously relax the requirements on the performance

of the rf control system, making it simpler and less expensive. As the experience from the cavities at HEPL demonstrates stiffening of the cavities should be very helpful in this respect. Calculations using lumped circuit models^{20,21,22} indicate that mechanical tuning of the cavities having not significantly more than nine cells can still be accomplished by deformation of the two end cells without destroying the field flatness by more than a few percent.

- At extremely high gradients the detuning due to radiation pressure will become the dominant effect and it is rather unlikely that the use of stiffening bars will reduce the problem significantly as one might expect, because once the total length of a cavity is fixed (as e.g. by a tuner) radiation pressure for reasons of symmetry will deform the individual cells keeping the equator distances unchanged. Therefore a cure would require either a more rigid individual cell or a 'compensated' cell shape (if possible and not contradicting other optimization criteria). From the rf point of view a self excited loop circuit seems to suited best to handle the problem of radiation pressure detuning.
- For recirculating linacs there is another attractive way to relax the requirements on the rf control system. Proper matching of the longitudinal beam optics of the recirculating arcs providing a longitudinal focus at the output of the accelerator can reduce the influence of amplitude- and phase jitter on the energy spread of the beam significantly. H. Herminghaus²³ recently demonstrated by tracking calculations that for the case of a 15 GeV accelerator using three linacs with five recirculations this reduction can amount to more than one order of magnitude.

Most important of all however certainly is a close cooperation and an exchange of experience between the (not so many) institutions working in the field of sc accelerators.

ACKNOWLEDGEMENT

The preparation of this review would have been impossible without the help of many colleagues from different accelerator institutions. I am very grateful to G. Geschonke, T. Linnecar, A. Mosnier, S. Noguchi, D. Proch, J. Sekutowicz and H. A. Schwettman for supplying me so generously with information about their operational experience. Discussions with B. Aune, J. Ben-Zvi, J. Delayen, J. Fuggitt, E. Haebel, H. Lengeler, K. W. Shepard and S. Simrock during the course of the last years have greatly contributed to my own understanding of the operational problems of sc cavities and their solutions. I am also very indebted to all members of the S-DALINAC group for their continuous support and help, in particular the contributions of T. Rietdorf, A. Stascheck and H. Weise during the preparation of the manuscript and the figures are gratefully acknowledged.

REFERENCES

1. M. S. McAshan et al., Appl. Phys. Lett., Vol. **22**, No. 11 (1973) 605.
2. P. Axel et al., IEEE Trans. Nucl. Sci. **NS-28**, 3 (1981) 2113.
3. K. Takata and Y. Kimura, Proc. of the 14th Int. Conf. on High Energy Acc., Part. Acc. **26** (1990) 87.
4. S. Mitsunobu et al., Proc. Fifth Workshop on RF Superconductivity, Hamburg, Germany (1991) 84.

5. C. Arnaud et al., Proc. of the 14th Int. Conf. on High Energy Acc., Part. Acc. **29** (1990) 47.
6. G. Cavallari et al., Proc. Fifth Workshop on RF Superconductivity, Hamburg, Germany (1991) 23.
7. H. Kempfert and M. Leenen, Proc. of the 14th Int. Conf. on High Energy Acc., Part. Acc. **26** (1990) 97.
8. B. Dwersteg et al., Proc. of the 14th Int. Conf. on High Energy Acc., Part. Acc. **29** (1990) 29.
9. A. Matheisen et al., Proc. Fifth Workshop on RF Superconductivity, Hamburg, Germany (1991) 44.
10. K. Alrutz-Ziemssen et al., Proc. of the 14th Int. Conf. on High Energy Acc., Part. Acc. **29** (1990) 53.
11. J. Auerhammer et al., Proc. Fifth Workshop on RF Superconductivity, Hamburg, Germany (1991) 110.
12. R. Sundelin et al., Proc. Fifth Workshop on RF Superconductivity, Hamburg, Germany (1991) 5.
13. B. Aune et al., Proc. Fourth Workshop on RF Superconductivity, Tsukuba, Japan (1989) 97.
14. K. W. Shepard, Proc. Fifth Workshop on RF Superconductivity, Hamburg, Germany (1991) 1.
15. J. K. Delayen et al., Proc. Fifth Workshop on RF Superconductivity, Hamburg, Germany (1991) 1.
16. J. Sikora et al., Proc. Third Workshop on RF Superconductivity, ANL-PHY-88-1, Argonne, Ill., USA (1988) 127.
17. B. Cauvin et al., Proc. Fourth Workshop on RF Superconductivity, Tsukuba, Japan (1989) 175.
18. L. R. Doolittle, Proc. Fourth Workshop on RF Superconductivity, KEK 89-12, Tsukuba, Japan (1990) 341.
19. J. R. Delayen, Ph. D. thesis, California Institute of Technology, Pasadena, Cal., USA, (1978).
20. D. Boussard, H. P. Kindermann and V. Rossi, Proc. European Part. Acc. Conf., Ed., Rome, Italy (1988) 985.
21. K. Akai et al., Proc. of the 14th Int. Conf. on High Energy Acc., Part. Acc. **29** (1990) 11.
22. T. Rietdorf, TH Darmstadt, Germany, private communication.
23. J. Sekutowicz, DESY, Hamburg, Germany, private communication.
24. G. Spalek, LANL, Los Alamos, NM., USA, private communication.
25. H. Herminghaus, Mainz University, Mainz, Germany, private communication.