

CERN/LHCC/2008-007

22 April 2008

Expression of Interest for an LHCb Upgrade

The LHCb Collaboration

Abstract

There is a growing international understanding that future flavour physics experiments will be required in the second half of the next decade to either study the flavour structure of new particles discovered at the LHC or to probe new physics at the multi-TeV scale. Here we present an expression of interest of the LHCb collaboration for an upgrade of the LHCb detector after it will have collected a data sample of about 10 fb^{-1} . We envisage this upgrade to enable the LHCb experiment to operate at 10 times the design luminosity, i.e. at about $2 \times 10^{33} \text{ cm}^{-2} \text{ s}^{-1}$, to improve the trigger efficiency for hadronic decays by a factor of two and to collect a data sample of $\sim 100 \text{ fb}^{-1}$. In this document we briefly describe the motivation for an LHCb upgrade. We then outline the R&D programme necessary to evaluate the required technologies for a high luminosity LHCb upgrade, which must take place over the next few years.

Contents

1	Introduction	1
2	Physics Case	1
2.1	Motivation	1
2.2	Experimental Sensitivities	2
3	LHCb Detector and LHC Luminosity	4
3.1	LHCb Detector	4
3.2	LHC Experimental Environment	5
4	The LHCb Trigger Upgrade	6
4.1	LHCb Triggers	6
4.2	LHCb Trigger Upgrade	7
5	LHCb Detector Upgrade	8
5.1	LHCb Electronics and DAQ Upgrade	8
5.2	LHCb Tracking Detectors Upgrade	9
5.2.1	VELO Upgrade	10
5.2.2	ST Upgrade	11
5.2.3	OT Upgrade	11
5.3	Particle Identification Upgrade	11
5.3.1	RICH Upgrade	11
5.3.2	Calorimeters Upgrade	11
5.3.3	Muon System Upgrade	12
6	Project Organisation	12
6.1	Organisation	12
6.2	R&D Plan	12

1 Introduction

LHCb is a dedicated heavy-flavour physics experiment designed to make precision measurements of CP violation and of rare decays of B hadrons at the Large Hadron Collider (LHC) [1]. LHCb will start taking data in 2008 and, during the following five years, expects to accumulate a data sample of $\sim 10 \text{ fb}^{-1}$. The large cross section of $500 \mu\text{b}$ for $b\bar{b}$ -quark production in pp collisions at 14 TeV centre-of-mass energy will allow LHCb to collect much larger data samples of B mesons than previously available. Using this data set, the LHCb experiment will be able to exploit the B_s meson system to make a first observation of the rare decay $B_s \rightarrow \mu^+ \mu^-$ and to measure the CP violating weak phase ϕ_s in $B_s \rightarrow J/\psi \phi$ down to the SM prediction, and to improve the precision on the CKM angle γ by a factor five.

At that time, continued running of the LHCb experiment much beyond 10 fb^{-1} without an upgrade will not be very profitable, since by running at constant peak luminosity the statistical precision on measurements increases very slowly.

In this document we express our interest to upgrade the LHCb experiment such that it can operate at 10 times the design luminosity, i.e. at about $2 \times 10^{33} \text{ cm}^{-2} \text{ s}^{-1}$, to improve the trigger efficiency for hadronic decays by a factor of two and to collect an integrated luminosity of about 100 fb^{-1} . This will increase the data samples by a factor of 10 and 20 for leptonic and hadronic decay modes, respectively.

We propose to start an R&D programme to evaluate the improvements which are required to upgrade the LHCb experiment. These include the design of new front-end electronics to read out the detector at 40 MHz and the development of a more radiation hard vertex detector sensor technology.

The LHCb upgrade does not require the planned LHC luminosity upgrade (SLHC) since the LHC design luminosity is $10^{34} \text{ cm}^{-2} \text{ s}^{-1}$. However it is compatible with and could operate at the SLHC.

This document is organised as follows: in Section 2 we present the motivation and scientific case for the LHCb upgrade. The LHCb detector and the LHC environment are described in Section 3. The LHCb trigger and detector upgrades are described in Sections 4 and 5. The project organisation and R&D plan are presented in Section 6.

2 Physics Case

2.1 Motivation

Many open fundamental questions of particle physics are related to flavour. Why are there three generations of quarks and leptons and what is their origin? How are the quark and neutrino mixing angles generated and what is the relation between the flavour couplings in the quark and lepton sector? What are the additional sources of CP violation required to satisfy the observed excess of matter over anti-matter? Future flavour physics experiments will be required to address these questions.

The Standard Model (SM) of particle physics is able to describe a wealth of experimental data. However despite its success up to energies of $\mathcal{O}(100 \text{ GeV})$, the SM is seen as an effective low-energy theory. Thus new physics beyond the SM is required for revealing the fundamental laws of physics at higher energies. The gauge sector of the SM is based on underlying symmetries which require the existence of the gauge bosons (γ , W , Z and gluons). However, the SM flavour sector is much less understood. There is an unexplained hierarchy in the masses and mixing of the quarks and leptons. In the SM, these are free parameters and there is no fundamental principle which governs the flavour structure.

The search for evidence of new physics (NP) beyond the Standard Model is indeed the main goal of particle physics over the next decade. The LHC at CERN will commence its operation in 2008 and start to look for the Higgs boson which is the last missing ingredient of the SM. The general purpose detectors (ATLAS and CMS) are designed to probe NP by searching for new particles which are expected in many models at the 1 TeV scale and would be produced at the LHC.

However probing NP at the TeV scale is not restricted to direct searches at the high-energy frontier. New particles could reveal themselves through virtual quantum effects in higher order processes. This has already happened several times in the past. Examples are the predictions for the existence of the charm quark and of the mass of the top quark before their respective discoveries. The larger the mass of these new particles the higher the precision that is required to reveal NP deviations from the SM.

Flavour physics is the best candidate to probe NP through quantum effects. In the SM, flavour-changing neutral currents (FCNC), neutral meson-antimeson mixing and CP violation are suppressed as these only occur through loop diagrams. Hence these decays are very sensitive to NP contributions which, in principle, could contribute with magnitude $\mathcal{O}(1)$ to these virtual

quantum loops. The NP flavour sector could also exhibit CP violation and be very different from what is observed in the SM.

In fact, the existing experimental limits for the flavour physics point to either a suppression of the couplings for NP or an even higher NP mass scale. Any NP model, built at the TeV scale to solve the gauge hierarchy problem, includes newly flavoured particles with a flavour structure and possibly CP violation. Experimental constraints then require a suppression of the flavour couplings and CP violating parameters in this model. Generally, this “flavour problem” puts very stringent restrictions on the parameter space of the fundamental properties of a NP model. The LHC will hopefully provide answers to some of the open questions of particle physics and, very possibly, produce a few new puzzles.

After the first five years of LHC operations, particle physics will reach a branch point. Either new physics beyond the Standard Model will have been discovered at the general purpose detectors and/or at LHCb, or new physics will be at a higher mass scale. If new particles are discovered in direct searches, it will be very difficult to understand what they represent. Their flavour structure must be studied to reveal their true nature. In both scenarios we will then almost certainly require a substantial increase in sensitivities to flavour observables, either to make progress in determining the flavour structure of the newly discovered particles or to probe NP through loop processes at even higher mass scales. If no NP is found in direct searches then flavour physics can still probe mass scales beyond the LHC energy frontier and either see its indirect effects or set better limits on their mass scale.

2.2 Experimental Sensitivities

The LHCb upgrade experiment, with its order of magnitude greater integrated luminosity of about 100 fb^{-1} and an improved hadron trigger, will collect data samples with an increase of a factor of 10 (20 for hadronic modes) in statistics. This will considerably improve upon the results from both the current B-factories and the first phase of the LHCb experiment. Many of these measurements are unique to the LHCb upgrade and complementary to the e^+e^- collider proposals.

With the LHCb upgrade we could perform measurements that are highly sensitive to NP effects, and channels with precise SM predictions are potential discovery channels. The effectiveness of these probes depends on the sensitivity of the measurements. Thus exploring new territory in sensitivities is crucial to the ability to make significant progress which will allow the LHCb upgrade to attack the flavour problem. The

Table 1: Expected sensitivity for the LHCb upgrade with an integrated luminosity of 100 fb^{-1} . A factor two of improvement for the Level-0 hadron trigger and systematic error estimates are shown as a range.

Observable	Sensitivity
$S(B_s \rightarrow \phi\phi)$	0.01 – 0.02
$S(B_d \rightarrow \phi K_S^0)$	0.025 – 0.035
$\phi_s (J/\psi\phi)$	0.003
$\sin(2\beta) (J/\psi K_S^0)$	0.003 – 0.010
$\gamma (B \rightarrow D^{(*)} K^{(*)})$	$< 1^\circ$
$\gamma (B_s \rightarrow D_s K)$	$1 - 2^\circ$
$\mathcal{B}(B_s \rightarrow \mu^+\mu^-)$	5 – 10%
$\mathcal{B}(B_d \rightarrow \mu^+\mu^-)$	3σ
$A_T^{(2)}(B \rightarrow K^{*0}\mu^+\mu^-)$	0.05 – 0.06
$A_{\text{FB}}(B \rightarrow K^{*0}\mu^+\mu^-) s_0$	0.07 GeV^2
$S(B_s \rightarrow \phi\gamma)$	0.016 – 0.025
$A^{\Delta\Gamma_s}(B_s \rightarrow \phi\gamma)$	0.030 – 0.050
charm x^2	2×10^{-5}
mixing y'	2.8×10^{-4}
CP y_{CP}	1.5×10^{-4}

results which will be measured at the LHC will hopefully provide guidance on where to focus the effort.

In Table 1 we present estimates for sensitivities in a few selected channels in a 100 fb^{-1} data sample. These are based on the following assumptions, which have yet to be demonstrated: maintaining trigger and reconstruction efficiencies at high luminosity running and, making use of a first level detached vertex trigger to double the trigger efficiency for hadronic modes. Systematic errors are only treated in a very simple way. Hence the quoted sensitivities have very large uncertainties and should be treated with caution. However, these estimates are useful to motivate simulation studies for validating these assumptions. In addition, as soon as LHCb will start taking data, the simulations for low luminosity running can be verified with data. Results from initial sensitivity studies have been presented in [2–5].

We now present additional details on the NP reach of entries in Table 1. New physics can be probed for by studying FCNC in hadronic $b \rightarrow s$ transitions. One approach is to compare the time-dependent CP asymmetry in a hadronic penguin loop decay with a decay based on a tree diagram when both decays have the same weak phase. In hadronic FCNC transitions unknown massive particles could make a sizable contribution to the $b \rightarrow s$ penguin loop whereas tree decays are generally insensitive to NP. The B-factories measure the CP asymmetry $\sin 2\beta^{\text{eff}}$ in the penguin decay $B^0 \rightarrow \phi K_S^0$. A value for $\sin 2\beta^{\text{eff}}$ which is different

from $\sin 2\beta$ measured in $B^0 \rightarrow J/\psi K_S^0$ would signal physics beyond the SM. Within the current available precision, all $\sin 2\beta^{\text{eff}}$ measurements are in reasonable agreement with the SM, but most central values are lower than expected. For example, we find for the decay $B^0 \rightarrow \phi K_S^0$ that $\Delta S(\phi K_S^0) = \sin 2\beta^{\text{eff}} - \sin 2\beta = 0.29 \pm 0.17$ [6].

This approach can also be applied to B_s mesons which will be exploited by LHCb. Within the SM the weak mixing phase ϕ_s is expected to be almost the same when comparing the time-dependent CP asymmetry of the hadronic penguin decay $B_s \rightarrow \phi\phi$ with the tree decay $B_s \rightarrow J/\psi\phi$. Due to a cancellation of the B_s mixing and decay phase, the SM prediction for the sine-term, $S(\phi\phi)$, in the time-dependent asymmetry of $B_s \rightarrow \phi\phi$ is very close to zero [7]. Thus any measurement of $S(\phi\phi) \neq 0$ would be a clear signal for new physics and definitively rule out Minimal Flavour Violation [8]. LHCb expects to collect 15.5k $B_s \rightarrow \phi\phi$ events in 10 fb^{-1} of data with a background to signal ratio $B/S < 0.8$ at 90% C.L [9]. The $S(\phi\phi)$ sensitivity has been studied using a toy Monte Carlo, taking resolutions and acceptance from the full simulation. After about 5 years LHCb expects to measure $S(\phi\phi)$ with a precision of $\sigma(S(\phi\phi)) = 0.05$ [9]. This precision is expected to be statistically limited, systematic errors are likely much lower.

The LHCb upgrade will substantially improve the measurement of $S(\phi\phi)$, since this is a hadronic decay mode which will benefit most from the first level detached vertex trigger. Scaling the sensitivity up to a data sample of 100 fb^{-1} , we estimate a precision of $\sigma(S(\phi\phi)) \sim 0.01$ to 0.02 rad. This sensitivity presents an exciting NP probe at the percent level which will arguably be (one of) the most precise time-dependent CP study in $b \rightarrow s$ transitions. In a similar study, the LHCb upgrade will be able to improve the $\sin 2\beta^{\text{eff}}$ sensitivity for $B_d \rightarrow \phi K_S^0$ to ~ 0.025 to 0.035 [10].

Using the tree decay $B_s \rightarrow J/\psi\phi$ LHCb will also probe NP in the CP violation of B_s mixing. With a 10 fb^{-1} data sample the weak phase ϕ_s will be determined with a precision of 0.01 [11]. This corresponds to $\sim 3.5\sigma$ significance for the SM expectation of ϕ_s for which the theoretical uncertainty is very small ($\mathcal{O}(0.1\%)$). This precision is expected to be still statistically limited. A significantly larger data-set would allow LHCb to search for NP in B meson mixing at an unprecedented level. An upgrade of LHCb has the potential to measure the SM value of ϕ_s with $\sim 10\sigma$ significance ($\sigma(\phi_s) \sim 0.003$) in $B_s \rightarrow J/\psi\phi$ decays. To control systematic errors at this level will be very challenging.

In the SM, the angle γ can be determined very precisely with tree decays which are theoretically very

clean. When combining all γ measurements in $B \rightarrow DK$ and $B_s \rightarrow D_s^\mp K^\pm$ (including systematics) 10 fb^{-1} of data will constrain the value of γ to about 2.5° . However, it will not be possible to push below the desired 1° precision. Therefore, a very precise determination of γ in tree decays is an important objective of the LHCb upgrade physics programme. The expected yields in 100 fb^{-1} of data are very large: examples are 620k $B_s \rightarrow D_s^\mp K^\pm$, 500k $B \rightarrow D(K_S^0 \pi^+ \pi^-)K$ and 5600k $B \rightarrow D(K\pi)K$ events, respectively. All these γ modes will benefit greatly from an improved first-level trigger strategy that does not rely solely on high transverse momentum hadrons. Simple statistical extrapolations show that several individual modes will give a potential statistical uncertainty close to 1° . Systematic uncertainties will clearly be very important. However, these uncertainties are largely uncorrelated amongst the modes and, in many cases, can be measured in control samples. Therefore, a global determination to below 1° of the tree level unitarity triangle should be achievable [13]. This will act as a standard candle to be compared to all loop determinations of the unitarity triangle parameters. Together with anticipated improvements in theory, this will allow to test the consistency of SM in the CKM matrix at the percent level.

The very rare decay $B_s \rightarrow \mu^+ \mu^-$ is key to many extensions beyond the SM. With a 100 fb^{-1} data sample the LHCb upgrade would be able to make a precision measurement of the branching ratio $\mathcal{B}(B_s \rightarrow \mu^+ \mu^-)$ to about $\sim 5\%$ at the SM level. This will allow the LHCb upgrade to either measure precisely the flavour properties of new SUSY particles discovered at the LHC or to put very stringent constraints on SUSY models in the large $\tan\beta$ regime which predict an enhanced decay rate for this mode [14].

The LHCb upgrade should also aim to observe the even rarer decay $B_d \rightarrow \mu^+ \mu^-$ which has a SM branching ratio of $(1.06 \pm 0.04) \times 10^{-10}$. The ratio $\mathcal{B}(B_d \rightarrow \mu^+ \mu^-)/\mathcal{B}(B_s \rightarrow \mu^+ \mu^-)$ is sensitive to new physics beyond the SM and will allow to distinguish between different models. This search will be extremely challenging as it requires an excellent understanding of the detector to reduce the muon fake rate due to backgrounds from hadronic two body modes to an acceptable level.

LHCb will exploit the semi-leptonic decay $B \rightarrow K^{*0} \mu^+ \mu^-$ which is sensitive to new physics in the small $\tan\beta$ range. LHCb expects to collect 7200 $B \rightarrow K^{*0} \mu^+ \mu^-$ per 2 fb^{-1} [15]. In addition to the forward-backward asymmetry, A_{FB} , these large data samples will allow LHCb to measure the differential decay rates in the di-muon mass squared, q^2 , and the angular distributions, and probe NP through the transversity am-

plitude $A_T^{(2)}$ and the K^{*0} longitudinal polarisation [16]. In the theoretically favoured region, $1 < q^2 < 6 \text{ GeV}^2/c^4$, the resolution in $A_T^{(2)}$ is estimated at 0.16 with 10 fb^{-1} of integrated luminosity [17]. While this data sample might provide a hint of NP, a ten-fold increase in statistics will allow to probe new physics at the few percent level and cover a large region of the MSSM parameter space. With a 100 fb^{-1} data sample the LHCb upgrade expects to collect 360k $B \rightarrow K^{*0} \mu^+ \mu^-$ events. The corresponding precision for $A_T^{(2)}$ is estimated to be 0.05 to 0.06.

There are several other channels which have a large potential for probing NP with a 100 fb^{-1} data sample. An excellent example is $B_s \rightarrow \phi \gamma$ which is sensitive to the photon polarisation and right-handed currents [18]. LHCb expects a yield of 11500 $B_s \rightarrow \phi \gamma$ events in 2 fb^{-1} of data with a background to signal ratio < 0.91 at 90% C.L. [19]. This decay is sensitive to NP arising in right-handed currents through the usual sine term $S(\phi \gamma)$ and a hyperbolic-sine term $A^{\Delta \Gamma_s}(\phi \gamma)$ which is due to the lifetime difference of the B_s mesons. With 10 fb^{-1} data the expected LHCb sensitivities are $\sigma(S(\phi \gamma)) = 0.05$ and $\sigma(A^{\Delta \Gamma_s}(\phi \gamma)) = 0.10$, respectively [20]. The LHCb upgrade will be able to improve these sensitivities to $\sigma(S(\phi \gamma)) = 0.016$ and $\sigma(A^{\Delta \Gamma_s}(\phi \gamma)) = 0.030$, and probe NP in right handed currents down to the intrinsic theoretical errors of the SM predictions.

With LHCb there are also possibilities for discoveries in measurements not involving B mesons. Compared to the results anticipated by the first phase of LHCb, the 20-fold increase of the charm sample would allow the LHCb upgrade to enhance substantially the search for NP sources in D^0 mixing and in CP violation of charm decays. SM predictions are typically negligible for these processes. The expected statistical sensitivity on the parameters x'^2 , y' and y_{CP} are 2×10^{-5} , 2.8×10^{-4} and 1.5×10^{-4} , respectively [21].

An LHCb upgrade could also probe new physics in lepton flavour violation. The best prospectives are in the decay mode $\tau \rightarrow \mu^+ \mu^- \mu^+$.

The Standard Model (SM) as well as SUSY or Extra Dimension models can be augmented by additional gauge sectors [22–24]. This is a very general consequence of string theories [25–27]. These gauge sectors can only be excited by high energy collisions. An example is the “hidden valley” sector. The manifestations of many of these models could be new v -flavoured particles with a long lifetime [22]. These can decay to a pair of b and \bar{b} quarks that produce jets in the detector. An example is the Higgs decay process $H \rightarrow \pi_v^0 \pi_v^0$ followed by $\pi_v^0 \rightarrow b\bar{b}$. LHCb is designed to detect b -flavoured hadrons and thus in a good position to detect decays of long-lived new particles. The LHCb

vertex detector (VELO) is $\sim 1 \text{ m}$ long making it possible to measure these decays. The LHCb upgrade will increase the sensitivity to much lower production cross section for these processes.

3 LHCb Detector and LHC Luminosity

3.1 LHCb Detector

The signal event yield S of the LHCb experiment is given by

$$S = L_{\text{int}} \times \sigma_{b\bar{b}} \times 2 \times f_B \times \text{BR}_{\text{vis}} \times \varepsilon_{\text{tot}}, \quad (1)$$

where L_{int} is the integrated luminosity and $\sigma_{b\bar{b}} = 500 \mu\text{b}$ is the $b\bar{b}$ production cross section. The probability for a b -quark to hadronize into a hadron is assumed to be $f_B = 39.1\%$ for B^0 or B^+ [28], 10.0% for B_s [28], and 8×10^{-4} for B_c^+ [29]. The factor 2 takes into account the production of both b - and \bar{b} -hadrons. BR_{vis} is the product of all branching ratios involved in the b -hadron decay of interest. The total signal efficiency ε_{tot} is the fraction of events containing a signal B decay that are triggered, reconstructed, and selected with offline cuts for physics analysis. It is illustrative to break ε_{tot} down into the following contributions to the efficiency:

$$\varepsilon_{\text{tot}} = \varepsilon_{\text{det}} \times \varepsilon_{\text{rec/det}} \times \varepsilon_{\text{sel/rec}} \times \varepsilon_{\text{trg/sel}},$$

where ε_{det} is the detection efficiency¹, $\varepsilon_{\text{rec/det}}$ is the reconstruction efficiency on detected events (track finding efficiency and neutral cluster reconstruction), $\varepsilon_{\text{sel/rec}}$ is the efficiency of the offline selection cuts on the reconstructed events (designed to discriminate against background), and $\varepsilon_{\text{trg/sel}}$ is the trigger efficiency on offline-selected events. The flavour tagging efficiency is not included in ε_{tot} . The values of all these efficiencies for two illustrative channels are given in Table 2.

The single largest inefficiency contribution is ε_{det} , which in turn is dominated by the geometrical acceptance in 4π . Figure 1 shows that the additional expense associated to even a modest increase in the aperture of the experiment, which is now $\vartheta_{\text{max}} = 300 \times 250$ mrad in the horizontal and vertical plane, respectively, and a 10 mrad beam pipe, would not lead to a significant improvement of the physics yield. The losses due to the material budget are also included in ε_{det} , and all effort should be made to reduce the material budget.

¹In practise ε_{det} contains everything which is not accounted for by the other factors, like the geometrical acceptance and all material effects in the detector, and is computed as $\varepsilon_{\text{tot}} / (\varepsilon_{\text{rec/det}} \times \varepsilon_{\text{sel/rec}} \times \varepsilon_{\text{trg/sel}})$.

Table 2: Summary of the signal efficiencies in % expected for LHCb. The meaning of the breakdown of the total efficiency ε_{tot} is explained in the text.

Decay channel	ε_{det}	$\varepsilon_{\text{det}}^{\text{rec}}$	$\varepsilon_{\text{rec}}^{\text{sel}}$	$\varepsilon_{\text{sel}}^{\text{trg}}$	ε_{tot}
$B_s \rightarrow \phi\phi$	6.7	79.7	37.9	23.2	0.470
$B^0 \rightarrow K^{*0}\mu^+\mu^-$	7.2	82.4	16.1	73.5	0.704

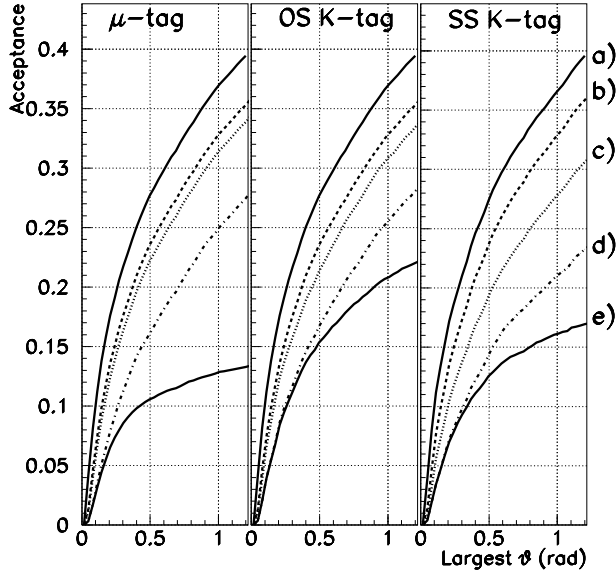

Figure 1: Geometrical acceptance for $B_s \rightarrow \phi\phi$, $\phi \rightarrow K^+K^-$, as a function of the maximum polar angle ϑ of one of the decay products. a) all $B_s \rightarrow \phi\phi$, b) and $\vartheta_K > 10$ mrad, c) and $\vartheta_{\text{tag}} > 10$ mrad, d) and ϑ_{tag} within same ϑ_{max} , e) and $p_\mu > 10$ GeV or $p_K > 2$ GeV.

It is not expected that the reconstruction efficiency can be significantly improved, and it would not result in any large gains in signal efficiency. The selection efficiency depends on the type and relative magnitude of background per channel, and the discriminating power of signatures like particle identification and narrow resonances. The selections have been optimised to reject inclusive $b\bar{b}$ background, and no large improvements are envisaged. Hence, this leaves two avenues to be followed to increase the total event yield: increasing L_{int} and improving the trigger efficiency for fully hadronic decay channels.

Before going into details about what is limiting the LHCb detector to already profit now from larger luminosities, what follows in the next section is a brief description of the experimental environment at the LHCb interaction point as a function of luminosity. After that the upgrade path of the trigger for both

increasing its efficiency and being able to cope with larger luminosities will be described. Then we will describe the consequences for all sub-systems in LHCb, and discuss their possible upgrades.

3.2 LHC Experimental Environment

The LHC machine has been designed to deliver a luminosity up to $10^{34} \text{ cm}^{-2} \text{ s}^{-1}$ at a General Purpose Detector (GPD). The optics around the LHCb interaction point (P8) allows LHCb to run at a luminosity up to 50% of the luminosity available at a GPD. Hence, the nominal LHC machine could deliver luminosities up to $5 \times 10^{33} \text{ cm}^{-2} \text{ s}^{-1}$ at P8, i.e. a factor 20–50 larger luminosity than what LHCb has been designed for².

The bunch crossing rate at P8 is given by the LHC machine to be 40.08 MHz, while 2622 out of the theoretically possible 3564 crossings [34] have protons in both bunches. Hence, the maximum rate of crossings with at least one pp interaction is ~ 30 MHz. The expected inelastic pp cross-section is 79 mb, of which 63 mb has at least two charged particles which can be reconstructed, the so-called visible cross-section. Figure 2 shows the number of crossings with at least one visible interaction and the mean number of visible interaction per crossing in crossings with at least one visible interaction as a function of luminosity. Note that increasing the luminosity from 2 to $10 \times 10^{32} \text{ cm}^{-2} \text{ s}^{-1}$ will only increase the mean number of interactions per crossing by a factor two, since the number of crossings with at least one interaction increases from 10 to 26 MHz. While the increase in occupancy for detectors which are only sensitive to pileup³ is small, spill-over⁴ increases linearly with luminosity as is indicated in the bottom plot of Figure 2. Note that the increase in occupancy in signal events for detectors which are sensitive to a single crossing only, is even less than indicated in the bottom plot of Figure 2, since signal

²While the nominal LHC is sufficient for the LHCb upgrade, there is a proposal to increase the nominal luminosity of the machine to $8 \times 10^{34} \text{ cm}^{-2} \text{ s}^{-1}$, the SLHC, around the middle of the next decade [35]. The SLHC bunch separation will remain 25 ns, but there are two scenarios to fill the bunches. The scheme preferred by LHCb will use large currents in the even bunches and a factor twenty lower current in the odd bunches. A suitable choice of the bunch structure should result in colliding odd with even bunches in P8, and odd×odd and even×even collisions at a GPD. This will allow LHCb to choose its luminosity using a combination of its β^* and the current in the odd bunches. A GPD will ignore the odd×odd interactions, since it will contribute a luminosity at least a factor 400 smaller than what is obtained in the even×even collisions.

³Pileup refers to additional pp interactions in a bunch crossing.

⁴Spill-over refers to hits in detectors which are caused by pp-interactions in preceding and/or following bunch crossings.

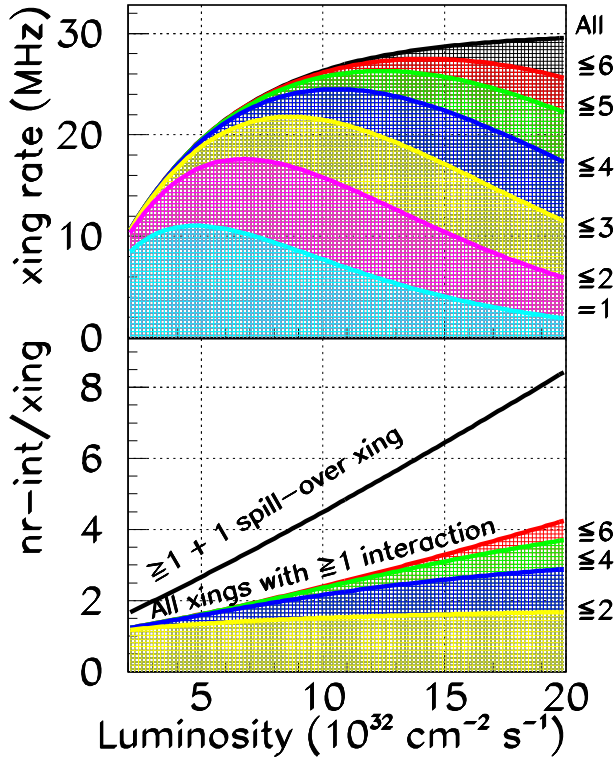

Figure 2: Top plot shows the number of crossings with visible pp-interactions as a function of luminosity. The bottom plot shows the average number of visible pp-interactions per crossing, for events with at least one pp-interaction.

events contain $\sim 50\%$ more tracks than visible interaction events.

4 The LHCb Trigger Upgrade

The description of the upgrade path of the trigger is preceded by a brief introduction of the present trigger architecture and its limitation to profit from higher luminosities.

4.1 LHCb Triggers

The LHCb trigger has two levels, called Level-0 (L0) and High Level Trigger (HLT) [30]. L0 is a trigger implemented in hardware, and its purpose is to reduce the rate of crossings with interactions to below a rate of 1.1 MHz, at which all LHCb data can be read out by the front-end (FE) electronics. L0 reconstructs the highest E_T hadron, electron and photon, and the two highest p_T muons. It triggers on events with a threshold of typically $E_T^{\text{hadron}} \gtrsim 3.5$ GeV, $E_T^{e,\gamma} \gtrsim 2.5$ GeV, and $p_T^\mu \gtrsim 1$ GeV at $2 \times 10^{32} \text{ cm}^{-2} \text{ s}^{-1}$. Even

for a $E_T^{\text{hadron}} \gtrsim 3.5$ GeV the hadron trigger (L0-h) rate at $2 \times 10^{32} \text{ cm}^{-2} \text{ s}^{-1}$ would exceed 1 MHz, hence L0 imposes additional cuts on the number of interactions per event and the track multiplicity to reduce the L0-h rate to 700 kHz. The L0-h efficiency for off-line selected $B_s \rightarrow \phi\phi$ is 30%, while the total L0 efficiency for this channel is $\sim 40\%$. The L0 efficiency for B decays with two muons in the final state is expected to be $\sim 90\%$ for a L0-rate of 160 kHz. The L0 e/γ trigger reaches efficiencies of $\sim 70\%$ for B decays with electrons and radiative B decays. The remainder of this section will concentrate on the two triggers with the largest and smallest efficiencies, hence L0- μ and L0-h respectively.

Figure 3 shows the yield of L0-triggered events, normalised to their yield at $2 \times 10^{32} \text{ cm}^{-2} \text{ s}^{-1}$ as a function of the luminosity for a leptonic and a hadronic B decay channel. The increase in the rate of crossings

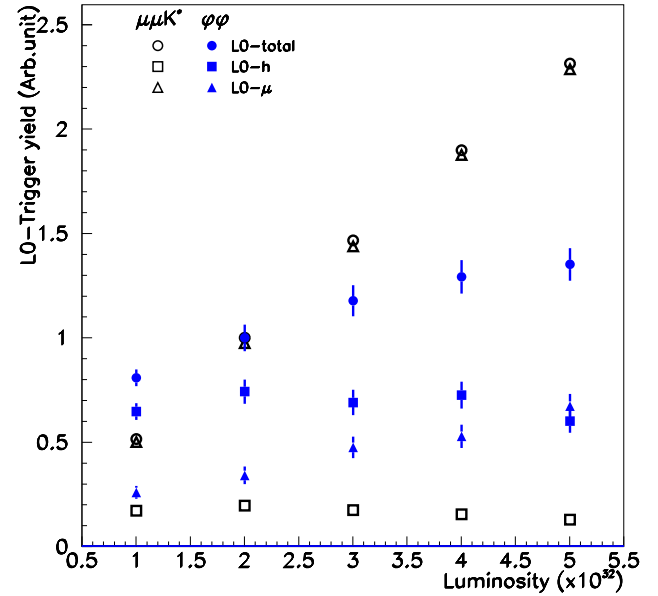

Figure 3: The L0-trigger yield as a function of luminosity for two decay channels: $\mu\mu K^*$ (open points) and $\phi\phi$ (closed points). The total L0-trigger yield, and the contributions from the L0-hadron and muon triggers are shown separately.

with at least one pp-interaction requires an increase in the E_T^{hadron} threshold, resulting in an almost constant yield for the hadron trigger. On the contrary, for L0- μ the loss in efficiency is minor, showing an almost linear dependence of signal yield on luminosity. Note that at $5 \times 10^{32} \text{ cm}^{-2} \text{ s}^{-1}$ about half the yield in $B_s \rightarrow \phi\phi$ is due to the muon trigger on the leptonic decay of the tagging B .

After L0, all detectors are read out, and full event building is performed on the CPU nodes of the Event

Filter Farm (EFF). The HLT consists of a C++ application which is running on every CPU of the EFF, which contains between 1000 and 2000 multi-core computing nodes. Each HLT application has access to all data in one event, and thus in principle could be executing the off-line selection algorithms, which would render it $\varepsilon_{\text{trg}/\text{sel}}=100\%$ by definition. But given the 1.1 MHz maximum output rate of L0 and the limited CPU power available, the HLT must reject the bulk of the events by using only part of the available information. The HLT starts with so-called alleys, where each alley addresses one of the trigger types of the L0-trigger, enriching the B -decay content of the events by refining the L0 objects, and adding impact parameter information. The hadron-alley has to deal with 1.3 L0-hadron clusters per event with $E_{\text{T}}^{\text{hadron}} \gtrsim 3.5$ GeV. The alleys search for tracks in roads seeded by the L0 objects. Applying a $100 \mu\text{m}$ impact parameter cut on these tracks reduces the rate of L0-h events by two orders of magnitude. If an event is selected by at least one alley, it is processed by the inclusive triggers, where specific resonances are reconstructed and selected, and the exclusive triggers, which aim to fully reconstruct B -hadron final states. Events will be written to storage with a rate of ~ 2 kHz.

In conclusion, an upgrade of the trigger should not only be able to cope with larger luminosities, but should be designed to at least gain a factor two to three in efficiency for hadronic B decays like $B_s \rightarrow \phi\phi$.

4.2 LHCb Trigger Upgrade

For pp collisions at 14 TeV $\sigma_{b\bar{b}}$ is assumed to be $500 \mu\text{b}$. Hence, with a luminosity of $2 \times 10^{33} \text{ cm}^{-2} \text{ s}^{-1}$ there will be 10^6 $b\bar{b}$ -pairs produced in the LHCb interaction point per second, of which 43% will have at least one B -hadron with a polar angle below 400 mrad , i.e. pointing in the direction of the spectrometer. Hence, an efficient and selective trigger needs to not only reject non- B background, but also needs to distinguish between wanted and unwanted B decays.

In the following discussion on the upgrade of the trigger, only the hadron trigger will be used as an example. The muon and e/γ triggers will also profit from the upgrade to be able to run at higher luminosities in much the same way. Pilot studies on improving the trigger show [31] that the only way to be able to provide adequate selectivity of the trigger, and maintain large efficiency for hadronic B decays is to be able to measure both the momentum and impact parameter of B decay products, i.e. the algorithm which is performed in the hadron alley described above.

The present front-end electronics (FEE) architecture imposes that the detectors which do not partic-

ipate in the L0-trigger can only be read out with a maximum event rate of 1.1 MHz, and that the L0-latency available for making the L0 decision, which is now $1.5 \mu\text{s}$ [34], can be stretched to a few μs at most. The algorithms required to efficiently select B decays require latencies far longer than what is possible with the present architecture.

Hence, the LHCb upgrade has opted for a FEE architecture which requires all sub-detectors to read-out their data at the full 40 MHz rate of the LHC machine. The data should be transmitted to a large EFF, where the trigger algorithm would be executed, just like the present HLT.

Figure 4 shows the rate of events with at least one cluster above a threshold in the hadronic calorimeter (HCAL) and the average number of HCAL-clusters above this threshold as a function of luminosity. The

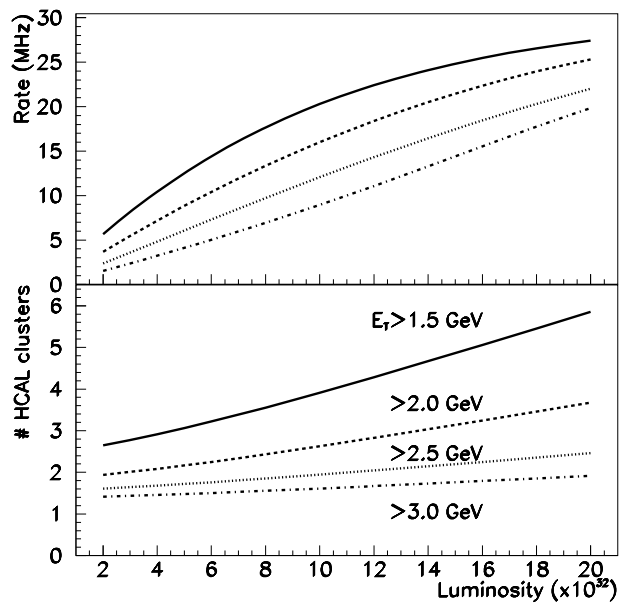

Figure 4: The rate of crossings with at least one HCAL cluster above the indicated threshold, and the number of clusters above this threshold, as a function of luminosity.

efficiency for an off-line reconstructed and selected $B_s \rightarrow \phi\phi$ event in a crossing with only a single pp-interaction is 96%, 85%, 72% and 46% for $E_{\text{T}}^{\text{hadron}} > 1.5, 2, 2.5$ and 3 GeV respectively. The number of high $E_{\text{T}}^{\text{hadron}}$ seeds per crossing does not rise drastically as a function of the luminosity, for example rising from 2 to 3.6 with $E_{\text{T}}^{\text{hadron}} > 2 \text{ GeV}$ for a factor ten increase in luminosity. But the equivalent rate at which the EFF has to be able to receive and process the events rises from 4 to 25 MHz.

The development of algorithms able to cope with the larger luminosities will require the following steps:

- Study the present hadron alley algorithms as a function of higher luminosities and lower HCAL thresholds with the present layout of LHCb.
- Investigate whether a modified layout of the experiment could further improve the trigger performance. As an example, study a detached vertex trigger as is described in [33].
- Study how best to achieve the required reduction of two orders of magnitude using both simulation and the first real data where applicable.

5 LHCb Detector Upgrade

Here we discuss the R&D plans for upgrading the LHCb detector systems, including electronics and data acquisition (DAQ).

5.1 LHCb Electronics and DAQ Upgrade

As is argued in the previous section: the entire front-end electronics and the DAQ system must be replaced and all event selection is done in software in a large CPU farm. The following requirements for the new front-end electronics (FEE) have been established:

- A readout into the DAQ system at full interaction rate must be possible. This requires everything to be read out at 40 MHz, albeit ~ 10 MHz of the bunches are actually empty.
- A “rate-control trigger” should cope with:
 - A staged DAQ system, which can not yet handle the full rate.
 - Unexpectedly high occupancies, which prevent the full readout.
 - Insufficient CPU power in the event-filter farm.

This “rate-control trigger” should not just pre-scale, but enrich the selected sample in good events. It corresponds closely to our current L0, however it can select rates up to 30 MHz.

The simplest solution to fulfil the above requirements is a fully synchronous readout at 40 MHz from the detector front-ends into the DAQ interface in the counting room. This solution corresponds to the highest data rate, and hence every effort will have to be made to keep the data-size small, e.g. by using binary tracking. Local zero-suppression for pixel detectors has to be accommodated to reduce their data size, but as a consequence, these detectors cannot be part of the

“rate-control trigger” mentioned above because it cannot be guaranteed that their data is available together with the other data for such a trigger due to its variation in data-length and consequently arrival time.

The “rate-control trigger” can then be fully implemented in the counting room, much like the current L0 muon trigger. An overview of the proposed architecture is shown in Figure 5. This solution has the following advantages:

- The front-end becomes simple.
- All information is available in the counting room; the “rate-control trigger” can operate there. No trigger decisions need to be brought back to the front-end.
- Having all information of every crossing available in the counting room will allow digital spill-over suppression for a detector if necessary.

For the front-end links we assume the availability of the Gigabit Bidirectional Trigger and Data link (GBT). As an example for the number of links consider a binary tracker with 10^6 channels, 100 kB of other data and 20 kB of overhead. At 40 MHz and 2.56 Gbit/s links this would require 30,000 links, hence the tracking systems must be binary or digital and higher link speeds can only be beneficial, also in view of the limited underground space for electronics. The DAQ will require an estimated bandwidth of 5×10^4 Gbits/s (assuming 100 kB@30 MHz and 50% average link load). A DAQ system with roughly 5000 10 Gigabit links will be needed. Currently there are two potential and commercial technologies, 10 Gigabit Ethernet (possibly 100 Gbit Ethernet) and 40 Gigabit InfiniBand. If the push-architecture is kept, the load balancing and destination assignment functionality of the Timing and Fast Control (TFC) system will be required. R&D will focus on these two technologies in close collaboration with the development of a “New Readout Board”.

Proposed R&D topics are:

- All sub-detectors need to replace or adapt their FEE to the new 40 MHz read-out scheme, and drive their data over the GBT link to the “New Readout Board”. The consequences for each sub-detector will be discussed in the sub-detector sections below.
- GBT chip: participate in development and push for the highest possible link speed.
- “New Readout Board” with at least 40 Gbit/s output bandwidth and the possibility to process 400 Gbit/s of input data.

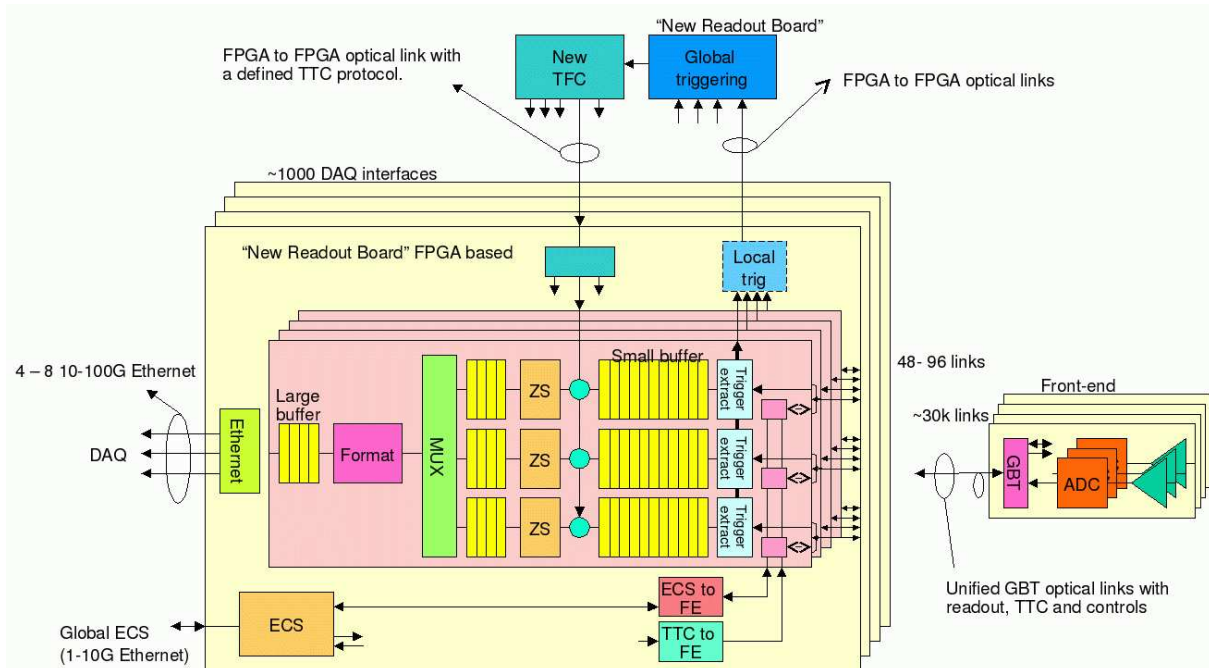

Figure 5: Schematic view of the proposed front-end electronics architecture.

- New TFC system based on GBT and “New Readout Board”.
- 10 Gigabit DAQ based 10 Gigabit Ethernet or InfiniBand.
- “Rate-control trigger” between 30 MHz and few MHz based on GBT and “New Readout Board”.

5.2 LHCb Tracking Detectors Upgrade

The performance of the current tracking system has been studied up to a luminosity $2 \times 10^{33} \text{ cm}^{-2} \text{ s}^{-1}$ using the LHCb reconstruction software and the following data samples:

- A sample of 14000 $B_d \rightarrow J/\psi(\mu\mu)K_S^0$ events generated at the default LHCb luminosity of $2 \times 10^{32} \text{ cm}^{-2} \text{ s}^{-1}$.
- Samples of 500 inclusive b events generated at luminosities of 5, 8, 10, 20 $\times 10^{32} \text{ cm}^{-2} \text{ s}^{-1}$.

The large sample of events at the nominal LHCb luminosity can be expressed in terms of the number of visible interactions and used to estimate the performance as a function of luminosity neglecting the effect of the increased spill-over from neighbouring crossings. This allows a comparison with a detector where the front-end electronics is only sensitive for one bunch crossing. The latter are referred to as the limited spill-over efficiency and ghost-rate. Figure 6 shows the

performance versus luminosity for the VELO tracking and long tracking⁵. For each algorithm four sets of points are shown: the event weighted efficiency, the event weighted ghost rate, the limited spill-over efficiency and the limited spill-over ghost rate. In both cases the performance slowly degrades as the luminosity increases. The most robust algorithm is the VELO tracking, for which the efficiency decreases only by 3.5% for a 10-fold increase in luminosity, albeit at the cost of a significant increase in ghost rate. The fact that the VELO tracking remains robust even at very high luminosities reflects the high segmentation of this detector, and the limited sensitivity to spill-over, but a reduction in spill-over sensitivity will reduce the ghost rate significantly. Above a luminosity of $5 \times 10^{32} \text{ cm}^{-2} \text{ s}^{-1}$ the difference between the long tracking performance with full spill-over and limited spill-over is clearly visible. The per track loss in tracking efficiency from $(2 \rightarrow 10) \times 10^{32} \text{ cm}^{-2} \text{ s}^{-1}$ is $\sim 5\%$, which is a small price to be paid, even for a 4-prong decay, compared to the factor 5 increase in luminosity. However, an additional increase of a factor two in luminosity would result in a loss of 34% of the 4-prong decays, hence would almost eliminate the additional factor two increase. It can also be seen that there is a sizable gain in performance at higher luminosities if the detector is only sensitive to one bunch-crossing.

⁵Long tracks traverse the full tracking setup from VELO to the T-stations. They are the most important set of tracks for B decay reconstruction.

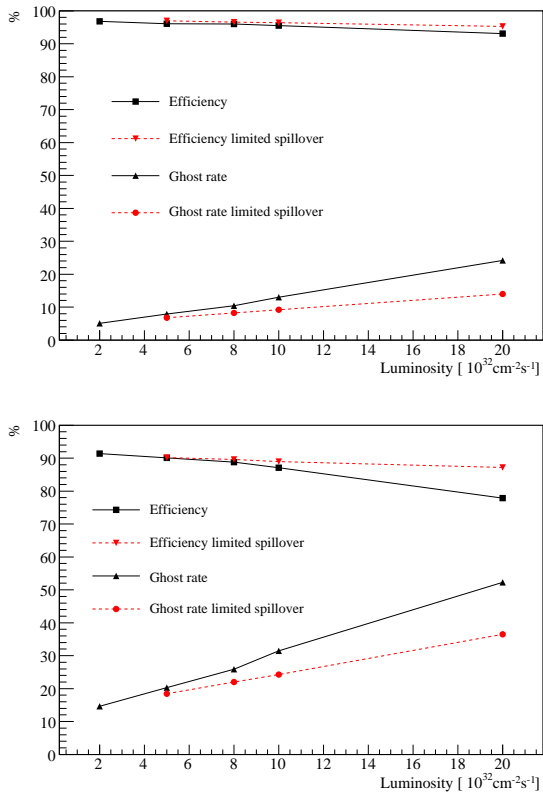

Figure 6: VELO (top) and long (bottom) tracking performance versus luminosity.

No attempt was made to tune the reconstruction performance for the increased luminosity, nor how to change the tracking detector set-up to adapt to the higher occupancies. The efficiency for finding the $b\bar{b}$ production vertex as a function of the number of visible collisions per crossing can be parametrised with $0.987^{nr-visible}$. Folding this together with the track reconstruction results given above gives a guide for what seems to be a reasonable luminosity to aim for as is shown in Figure 7. If the tracking performance would follow the results obtained with limited spill-over, the luminosity to aim for is $\sim 3 \times 10^{33} \text{ cm}^{-2} \text{ s}^{-1}$, while larger luminosities would hardly improve the yield in multi-prong decays.

Hence R&D efforts will study:

- How to exploit the possibilities of spill-over recognition/rejection offered by the upgraded FEE, which will have all information of every crossing available in the counting room.
- What modifications in the tracking detectors will allow us to maintain the high reconstruction efficiency at low ghost rate for the highest luminosities. Initially the following options will be

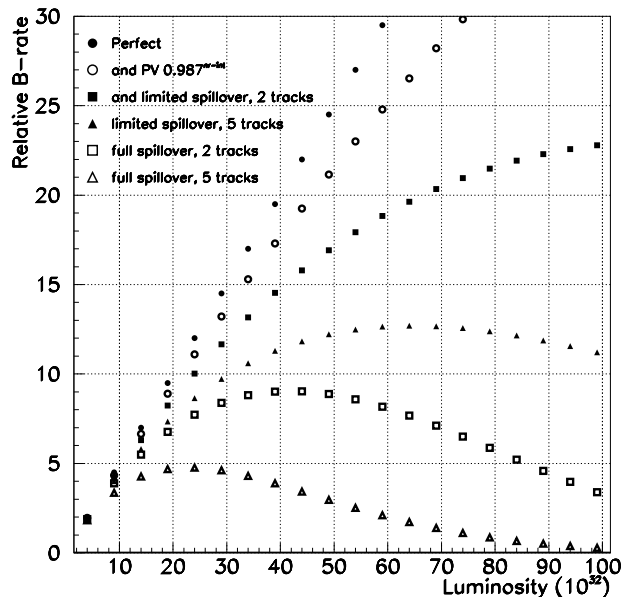

Figure 7: The expected yield of reconstructed B decays as a function of luminosity. The B -yield is normalised to the yield at $2 \times 10^{32} \text{ cm}^{-2} \text{ s}^{-1}$.

investigated:

- VELO with pixel detectors.
- Adding extra planes to TT.
- Enlarging the IT surface to reduce the OT occupancy.
- Redesign of the Tracker stations, integrated with a new RICH, including fibre-trackers and/or a Transition-Radiation Tracker (TRT).

5.2.1 VELO Upgrade

The VELO silicon sensors are located only 7 mm from the LHC beams. For 2 fb^{-1} of integrated luminosity the inner active strips are expected to receive a dose of up to $1.3 \times 10^{14} \text{ 1 MeV neutron equivalents/cm}^2$. Since the upgrade aims at collecting at least 100 fb^{-1} , the main issue for the VELO is radiation hardness. The initial LHCb VELO is expected to operate without any substantial loss of efficiency and spatial resolution up to 6 fb^{-1} data, assuming that no major beam loss event occurs. A replacement of the silicon modules is foreseen that will allow completion of the initial phase of LHCb data taking.

The upgrade will require significant changes to the VELO. Initial prototype sensors of both short strips (strixels) and pixels, with simple geometry, to allow comparative technology studies, have been designed and are being fabricated (in conjunction with RD50). The VELO group is planning a series of test beam

studies that will validate the geometry and technology choices. Potential improvements to the RF-foil will be considered and their impact on the material budget of the detector evaluated.

Depending on the choice for a strixel or pixel detector a new FEE-ASIC needs to be designed. Like for the present VELO a strixel chip will be shared with the Si-strip ST detector, while depending on the choice of the photon detector of the RICH the pixel ASIC could be shared with a new HPD.

The following R&D topics are proposed:

- Study the implementation of the 40 MHz read-out for the VELO, e.g. zero suppression for a pixel design,
- optimising the sensor geometry for the strixel and pixel options.
- evaluate the radiation hardness of the technologies under consideration.

5.2.2 ST Upgrade

As mentioned above the FE-electronics needs to be replaced.

The radiation length of the IT is completely dominated by the electronics and cabling. The challenge of a system re-design is to reduce the radiation length of the electronics, while increasing to 40 MHz synchronous readout and avoiding any significant cabling.

With an expected total 1-MeV neutron equivalent fluence at the innermost regions of IT of below 10^{14} cm^{-2} no significant radiation problems are expected.

5.2.3 OT Upgrade

As is shown in Section 5.2 the main degradation in tracking performance of the present long tracking is due to the large increase in spill-over hits. These studies have been performed using a 75 ns wide OT time window to accommodate the drift time, signal delay along the wire and t_0 offset variation over the chambers. The OT has 5 mm diameter straws, which corresponds to a maximum drift time of 33 ns with the chosen gas composition, which could be shortened at the expense of a deteriorated resolution. The choice of tracking technology to cover the large OT area relies heavily on the tracking studies which need to exploit the effectively rather short OT drift time, and define a new optimum of drift time versus resolution.

Assuming that based on these studies the OT technology can still be used in most of the area to be covered, the front-end electronics would require a complete redesign, possibly with the exception of the ASDBLR and of the TDC core of the OTIS chip.

5.3 Particle Identification Upgrade

5.3.1 RICH Upgrade

As mentioned above, increasing the luminosity by a factor of 10, from 2×10^{32} to $2 \times 10^{33} \text{ cm}^{-2} \text{ s}^{-1}$ results in only a factor 2.3 increase in the detector occupancy for signal events. The particle identification algorithm in the RICH is particularly sensitive to the correct treatment of background hits for which no tracks have been reconstructed. Using a now obsolete version of the code, an upper limit of the degradation of the kaon identification efficiency can be set at $\sim 10\%$. Repeating this study with the present more robust software, and tuning the parameters to accommodate the larger background will reduce this loss significantly.

To adapt to the 40 MHz read-out, the photon detector, which is now a HPD, has to be redesigned. Given the present performance of the HPD, with only about ten noise hits measure in over two million installed pixels, keeping the same detector technology seems attractive, but alternative solutions will also be considered.

For the mechanical structures and optics two options are discussed:

- Leave mechanical structures as they are and only redesign the photon detector. This is the simplest solution which will only require minor rearrangements in the photon detector housing structure. However, the occupancy in RICH 1 has to be studied.
- Take this opportunity to reduce the amount of material before the magnet significantly. Remove RICH1, and design a new particle identification system, covering the full solid angle of the spectrometer, which should then replace RICH2, and possibly be combined with the Tracker stations. Here one also considers a possible inclusion of a Time-of-flight (TOF) detector and/or a Transition Radiation Tracker (TRT) in this upgraded RICH/tracking system.

5.3.2 Calorimeters Upgrade

The radiative penguin decay $B_s \rightarrow \phi\gamma$ is one of the benchmark processes for the feasibility study of the electromagnetic calorimeter (ECAL) performance at $2 \times 10^{33} \text{ cm}^{-2} \text{ s}^{-1}$. Preliminary studies show only a minor degradation of the signal selection efficiency with the current ECAL [32]. The study of background suppression is ongoing. It is not excluded that more efficient background suppression would necessitate an upgrade of the ECAL inner section in order to improve its granularity and energy resolution.

Another critical issue of running the ECAL at one order of magnitude higher luminosity is the radiation hardness of the ECAL modules and electronics. Front-End boards on top of the ECAL platform can probably sustain a radiation dose equivalent to 100 fb^{-1} . For the energy resolution we assume a radiation degradation as measured at LIL neglecting a quite probable increase in annealing due to a lower dose delivery rate expected during LHCb running. The actual performance of the ECAL modules under irradiation will be closely monitored using a dedicated ECAL monitoring system. The effects induced by irradiation of 2.2 Mrad leads to an increase of the constant term from 0.8% up to 1.5%. Assuming a degradation in ECAL resolution above this level to be unacceptable about half of the inner ECAL section (84 modules) has to be replaced after 3 years of operation at $2 \times 10^{33} \text{ cm}^{-2} \text{ s}^{-1}$.

The present hadron calorimeter (HCAL) will be maintained if the upgrade adopts a hadron trigger scheme as discussed in section 4. Detailed irradiation studies of HCAL have shown that after two years of running at a luminosity of $2 \times 10^{33} \text{ cm}^{-2} \text{ s}^{-1}$ the resolution will degrade from 10% to 15% (constant term) for the inner most modules closest to the beam pipe [32]. This should allow to operate the present HCAL without major deterioration of the hadron trigger performance.

The FE-boards need to be replaced to accommodate the increase of full read-out from 1 to 40 MHz.

5.3.3 Muon System Upgrade

In the present L0- μ trigger M1 improves the momentum resolution by $\sim 30\%$. In the upgrade, M1 will no longer be needed, since the momentum of muon candidates found in M2–M5 will be determined by the tracking system behind the magnet. Hence, M1 can be removed. The muon system is the more shielded sub-detector, therefore the primary component of the particle flux is less dominant than in other subsystems. Most of the hits that will be recorded by the chambers in the stations M2–M5 will be produced by low energy secondary particles produced by electromagnetic and hadronic showers, leading to a larger uncertainty in MC predictions. This uncertainty will be resolved after the first year of operation of LHCb. Ageing of MWPC is of particular concern in the high luminosity regime. The accumulated charge for an exposure of 100 fb^{-1} shows that ageing should be acceptable for the whole system, with the possible exception of region M2R1, i.e. the first station after the calorimeters close to the beam-pipe. After the first actual background measurements in LHCb it should be assessed if this part of the muon system needs to be replaced with the same technology as is now used for M1R1,

where triple-GEM type of detectors are employed.

The present muon trigger data is already transmitted at a rate of 40 MHz over optical fibres to the L0 muon trigger boards, in much the same way as should be implemented with the “New Readout Board” replacing the muon trigger boards.

6 Project Organisation

6.1 Organisation

The LHCb management and collaboration set up the LHCb upgrade working group in March 2007. The mandate of the LHCb upgrade working group is

- to produce a document making the case for the LHCb upgrade,
- to coordinate the upgrade effort,
- to define the R&D required for detector, electronics read-out and trigger upgrade,
- to report to the LHCb management (Technical Board) and Collaboration Board.

Each LHCb sub-detector has nominated a representative to the upgrade working group, and these act as liaisons with their detector upgrade communities.

6.2 R&D Plan

The LHCb experiment is now proposing an R&D programme to start evaluating the technologies for a high luminosity LHCb upgrade. Areas and possible avenues where R&D effort is required are outlined in sections 4.2, 5.1, 5.2, and 5.3. Here we summarise the important issues:

- development of trigger algorithms which are able to cope with the higher luminosities,
- development of a 40 MHz front-end electronics for all sub-detectors,
- development of a DAQ system with an estimated bandwidth of 5×10^4 Gbits/s,
- evaluate the radiation hardness for the vertex detector sensor technologies: short Si-strips (strixel) and pixels,
- study modifications of the tracking detectors (OT, IT and TT) required for maintaining the high reconstruction efficiency at a low ghost rate,
- develop a replacement photo detector for the Ring Imaging Cherenkov detector (RICH),

- evaluate the performance of the electromagnetic calorimeter (ECAL), and study possible replacement options for the inner ECAL modules,
- confirm with data that the muon system will cope with high luminosity running.

The sub-detector system have been invited to produce more detailed R&D proposals. The status of these plans is detailed in ref. [36]. For example, the vertex detector groups have already started to study performance and radiation hardness of detector sensors. The R&D should provide the necessary information to submit a TDR of an upgraded detector by the beginning of the next decade. This detector TDR will also contain detailed costings.

References

- [1] R. Antunes Nobrega *et al.*, “LHCb Reoptimised Detector Design and Performance TDR”, LHCb TDR 9, CERN/LHCC/2003-30 (2003).
- [2] F. Muheim, “LHCb Upgrade Plans”, Nucl. Phys. Proc. Suppl. 170 (2007) 317.
- [3] H. Dijkstra, “The LHCb Upgrade”, at FPCP07, Bled, Slovenia, May 2007, arXiv:0708.2665v1 [hep-ex]
- [4] C. Parkes, “The LHCb upgrade”, Nucl. Instrum. Meth. A **569**, 115 (2006).
- [5] C. Parkes, “The LHCb Detector”, at EPS07, Manchester, UK, July 2007.
- [6] Heavy Flavour Averaging Group, updated Summer 2007, <http://www.slac.stanford.edu/xorg/hfag/>
- [7] M. Raidal, Phys. Rev. Lett. **89** (2002) 231803 [arXiv:hep-ph/0208091].
- [8] G. D’Ambrosio, G. F. Giudice, G. Isidori and A. Strumia, Nucl. Phys. B **645** (2002) 155 [arXiv:hep-ph/0207036].
- [9] S. Amato, J. McCarron, F. Muheim, B. Souza de Paula, Y. Xie, LHCb Public note, LHCb-2007-047.
- [10] Y. Xie, LHCb Public note, LHCb-2007-130.
- [11] O. Schneider at 1st LHCb Collaboration Upgrade Workshop, January 2007, available from <http://indico.cern.ch/conferenceDisplay.py?confId=8351>
- [12] I. I. Bigi and A. I. Sanda, Nucl. Phys. B **193** (1981) 85.
- [13] G. Wilkinson at 1st LHCb Collaboration Upgrade Workshop, January 2007, available from <http://indico.cern.ch/conferenceDisplay.py?confId=8351>
- [14] J. R. Ellis, K. A. Olive and V. C. Spanos, Phys. Lett. B **624** (2005) 47 [arXiv:hep-ph/0504196].
- [15] J. Dickens, V. Gibson, C. Lazzeroni, M. Patel, LHCb Public note, LHCb-2007-038.
- [16] F. Krüger and J. Matias, Phys. Rev. D **71** (2005) 094009 [hep-ph/0502060].
- [17] U. Egede, LHCb Public note, LHCb-2007-057.
- [18] D. Atwood, M. Gronau and A. Soni, Phys. Rev. Lett. **79** (1997) 185 [arXiv:hep-ph/9704272].
- [19] L. Shchutska, I. Belyaev, A. Golutvin, LHCb Public note, LHCb-2007-030 (2007).
- [20] L. Shchutska *et al.* LHCb Public note, LHCb-2007-147 (2008).
- [21] M. Artuso *et al.*, arXiv:0801.1833 [hep-ph].
- [22] M. J. Strassler and K. M. Zurek [hep-ph/0604261].
- [23] M. J. Strassler and K. M. Zurek [hep-ph/0605193].
- [24] M. J. Strassler, [hep-ph/0607160].
- [25] M. Cvetič, P. Langacker and G. Shiu, Phys. Rev. D **66** (2002) 066004 [arXiv:hep-ph/0205252].
- [26] N. Arkani-Hamed, S. Dimopoulos and S. Kachru, [hep-th/0501082].
- [27] V. Barger, P. Langacker and G. Shaughnessy, New J. Phys. **9** (2007) 333 [arXiv:hep-ph/0702001].
- [28] Particle Data Group, K. Hagiwara *et al.*, Phys. Rev. D **66** (2002) 010001, and 2003 off-year partial update for the 2004 edition available on the PDG web site: <http://pdg.lbl.gov/>.
- [29] O.P. Yushchenko, LHCb/2003-113.
- [30] LHCb collaboration, R. Antunes Nobrega *et al.*, LHCb Trigger System, CERN-LHCC/2003-031.
- [31] H. Dijkstra at 1st LHCb Collaboration Upgrade Workshop, January 2007, available from <http://indico.cern.ch/conferenceDisplay.py?confId=8351>
- [32] A. Schopper at 1st LHCb Collaboration Upgrade Workshop, January 2007, available from <http://indico.cern.ch/conferenceDisplay.py?confId=8351>

- [33] E. Gottschalk at 1st LHCb Collaboration Upgrade Workshop, January 2007, available from <http://indico.cern.ch/conferenceDisplay.py?confId=8351>
- [34] J. Christiansen, LHCb 2001-014.
- [35] Minutes Joint PAF-POFPA meeting, February 13 2007, EDMS ID 820244.
- [36] LHCb Upgrade, LHCb note in preparation (2008).