

EUROPEAN ORGANIZATION FOR NUCLEAR RESEARCH  
European Laboratory for Particle Physics



*Large Hadron Collider Project*

**LHC Project Report 1081**

**COOLDOWN OF THE FIRST SECTOR OF THE LARGE HADRON COLLIDER:  
COMPARISON BETWEEN MATHEMATICAL MODEL AND MEASUREMENTS**

L. Liu<sup>1</sup>, G. Riddone<sup>2</sup>, L. Serio<sup>2</sup> and L. Tavian<sup>2</sup>

**Abstract**

The first 3.3-km long LHC sector (sector 7-8) was cooled down for the first time from room temperature to below 2.0 K from January to March, 2007. In this paper, the measured cool-down evolution of the sector is presented and compared with the calculated results. The discrepancies between the measured and calculated data are analyzed. In addition, two unexpected phenomena, unbalanced cool-down between two neighboring cells supplied by one valve, and longer cool-down time with respect to the predicted generic cool-down are thoroughly and numerically analyzed.

1 Technical Institute of Physics and Chemistry, Chinese Academy of Sciences, Beijing, China

2 CERN, Accelerator Technology Department, Geneva, Switzerland

Presented at the 2007 Cryogenic Engineering Conference and International Cryogenic Materials Conference  
CEC-ICMC2007

16-20 July 2007, Chattanooga, USA

CERN  
CH - 1211 Geneva 23  
Switzerland

Geneva, 10/12/2007

# COOLDOWN OF THE FIRST SECTOR OF THE LARGE HADRON COLLIDER: COMPARISON BETWEEN MATHEMATICAL MODEL AND MEASUREMENTS

L. Liu<sup>1</sup>, G. Riddone<sup>2</sup>, L. Serio<sup>2</sup> and L. Tavian<sup>2</sup>

<sup>1</sup> Technical Institute of Physics and Chemistry, Chinese Academy of Sciences, P. O. Box 2711, Beijing 100080, China

<sup>2</sup> Accelerator Technology Division, CERN,  
CH-1211 Geneva 23, Switzerland

## ABSTRACT

The first 3.3-km long LHC sector (sector 7-8) was cooled down for the first time from room temperature to below 2.0 K from January to March, 2007. In this paper, the measured cool-down evolution of the sector is presented and compared with the calculated results. The discrepancies between the measured and calculated data are analyzed. In addition, two unexpected phenomena, unbalanced cool-down between two neighboring cells supplied by one valve, and longer cool-down time with respect to the predicted generic cool-down are thoroughly and numerically analyzed.

**KEYWORDS:** LHC, cool-down, superconducting magnet, helium cryogenics

## INTRODUCTION

The cool-down of the first LHC sector (sector 7-8) started for the first time on January 15, 2007 [1-2]. The cool-down operation consists of three main phases. The first phase from 300 K to 80 K is performed by evaporating large quantities of liquid nitrogen which pre-cools a helium flow entering the sector. The second phase from 80 K to 4.5 K is performed by using the cooling capacity of the expansion turbines of the 4.5 K refrigerator. The last phase from 4.5 K to 1.9 K is carried out using the cooling capacity of the 1.8 K refrigeration unit. After about two months, the temperatures of all the magnets were below 2 K. Discrepancies between the measured, calculated and predicted generic cool-down evolutions [3] were observed and analyzed. The unexpected phenomenon of unbalanced cool-down between neighboring cells supplied in parallel has also been analyzed. In the following sections, only the two first cool-down phases are considered.

## COOL-DOWN OF THE FIRST LHC SECTOR

### Cool-down Flow Scheme

The generic flow scheme for the cool-down from room temperature to 4.5 K of a typical LHC sector is shown in FIGURE 1. The refrigerator is hydraulically connected to each cell of the sector via the cooling headers C, D, E, F and related control valves. All LHC cells, which belong to the regular arc (about 107 m each), dispersion suppressor next to and opposite the refrigerator (DSN/O) (cell length varying from 80 m to 95 m) and the Long Straight Section next to and opposite the refrigerator (LSSN/O) respectively, are cooled down in parallel.

During the cool-down, the helium to the magnet cold mass is supplied via headers C, E, F and returned via header D. Cool-down and fill valves (CV920) distribute and control the flow-rate in each magnet cell. For all magnet cells in the LSSN/O and a special cell in the mid-arc, one valve feeds one cell, while for the other standard cells in the arc and all cells in the DSN/O, two neighboring cells are fed by one valve. On-off quench valves (QV) are open at cell outlets allowing return flow to the header D.

### Cool-down Evolution

FIGURE 2 and FIGURE 3 show the temperature evolutions of the first cool-down of sector 7-8 from 300 K to 80 K and from 80 K to 4.5 K, respectively. For comparison, the measured and calculated average temperature of magnets and return temperature of the sector are given in the same figure. The calculated values are determined with the measured inlet temperature and mass flow rate of the sector. The calculated average temperature of magnets is basically in agreement with the measured data: they have a very similar evolution and the average difference is only 8.1 K during the first phase (from 300 K to 80 K) and 1.0 K during the second phase (from 80 K to 4.5 K). The maximum temperature difference is 19 K in the first phase and 18 K in the second phase.

The discrepancies between the measured and calculated evolutions are mainly due to:

- the mass flow rate distribution which is fixed in the simulation to allow synchronous cool-down of cells and which is more disparate during the real cool-down,
- the measured average temperature which is based on temperature measurement located at the magnet cold mass periphery and which is not entirely representative of the average temperature of the magnet,
- the readings of some magnet temperatures which are missing and do not allow measurement of the real cell temperature profile,
- the uncertainty on the total mass flow measurement which is estimated at about 5% and which directly influences the cool-down capacity.

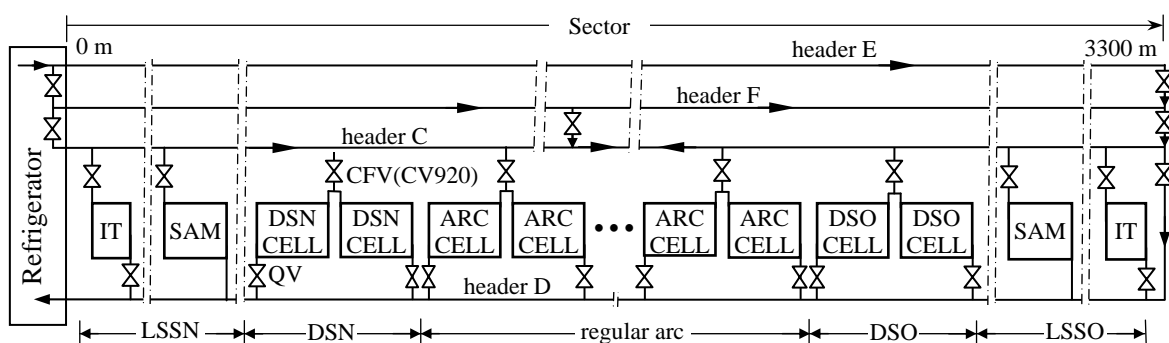


FIGURE 1. Generic flow-scheme for the cool-down from 300 K to 4.5 K of a typical LHC sector.

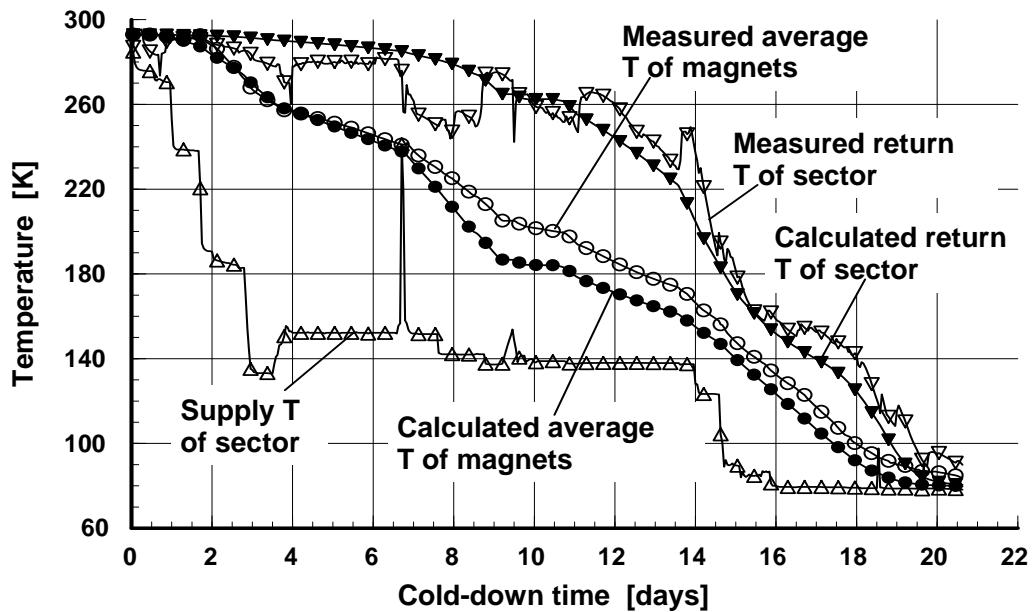


FIGURE 2. Calculated and measured temperature evolution from 300 K to 80 K of sector 7-8.

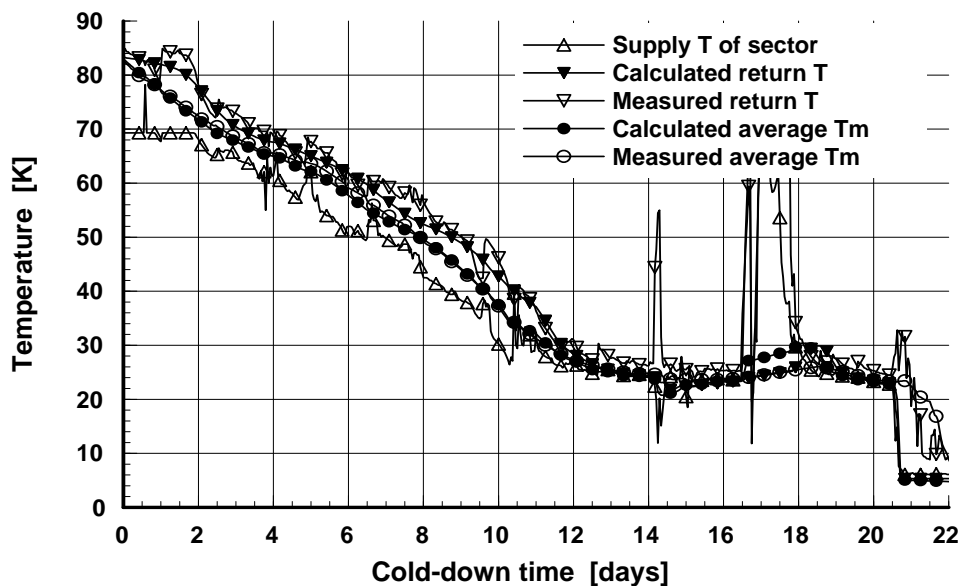


FIGURE 3. Calculated and measured temperature evolution from 80 K to 4.5 K of sector 7-8.

### Temperature and Pressure Profiles of Headers

FIGURE 4 shows the measured and calculated temperature and pressure profiles of the supply and return headers at a given time. The deviation in temperature is caused by the different flow distribution in headers C, E and F. When the flow in headers E and F is increasing, the 'zero flow' position in header C is closer to the refrigerator. Due to the unequal flow distribution (less flow is supplied to the cells far away from the refrigerator in the simulation), the measured and calculated pressure profiles in header D are significantly different. Nevertheless, the total pressure drops along header D are identical.

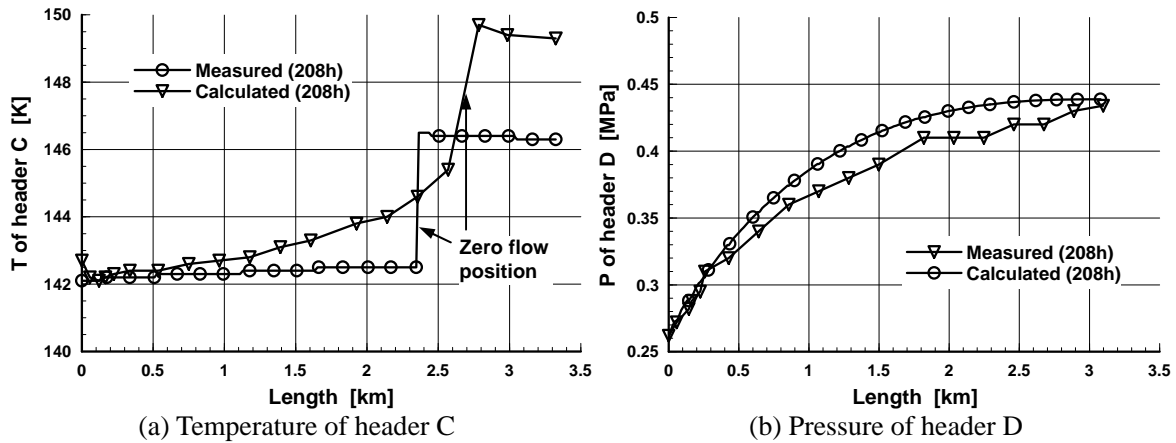


FIGURE 4. Measured and calculated temperature and pressure profiles of header C and D at 208 h.

## ANALYSIS OF UNBALANCED COOL-DOWN

### Local Flow Scheme

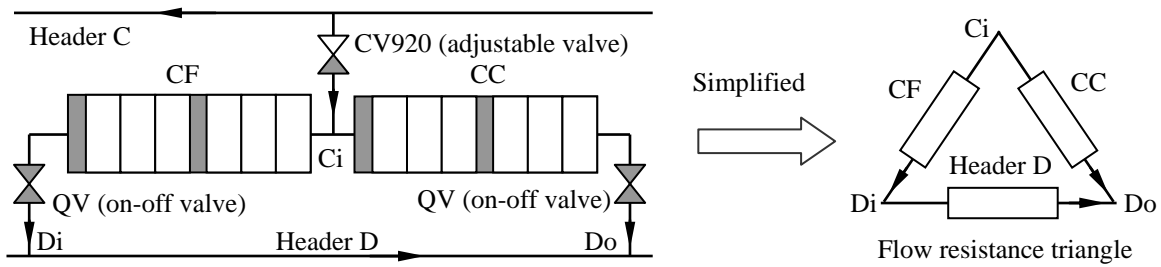
During the first cool-down, one of the unexpected phenomena is the unbalanced cool-down between Two Neighboring Cells (TNC) supplied by one valve. In order to present and analyze the unbalance, a local sub-system of the generic flow scheme is extracted and shown in FIGURE 5. This scheme includes a TNC with the adjustable inlet valve (CV920), two outlet on-off valves (QV) and a segment of header D (about 214 m long) between the two on-off valves. In the following, the TNC cell which is far away from the refrigerator is called CF while the cell closer to the refrigerator is named CC.

### Unbalanced Cool-down Phenomenon

FIGURE 6 presents the unbalanced cooling observed during the first cool-down. The cool-down evolutions of two TNCs are recorded. Among the two TNCs, one is close to the refrigerator (Q21/23L8, 1.0 km away) and the other is far from the refrigerator (Q19/21R7, 2.4 km away). After about one day of cool-down, the temperatures of the two CC cells start to decrease, whereas the two CF cells do not show any temperature drop till the fourth day (after that the unbalance was corrected by operators). The plateaus of the Q21L8 curve have been created by closing CV920 to balance the cool-down flow to different TNCs. In addition, the degree of unbalance depends on the location of the TNCs. If the TNC is closer to the refrigerator (Q21/23L8), the unbalance is larger.

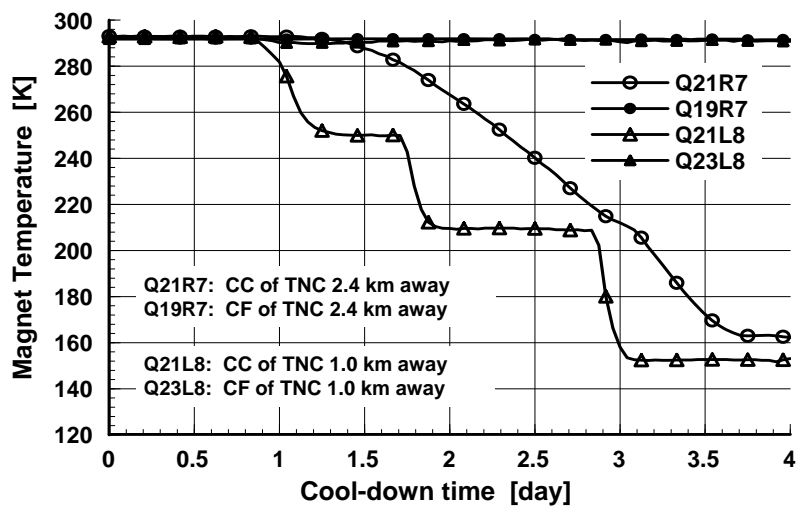
### Analysis of the Unbalanced Cool-down

To analyze the unbalanced cool-down, the model shown in FIGURE 5 can be simplified into a flow resistance triangle (shown on the right side of FIGURE 5) with  $C_i$ ,  $D_i$ ,  $D_o$  its three summits. There are two paths for the flow from  $C_i$  to  $D_o$ , one is directly through the CC cell, the other is via  $D_i$  with the CF cell in series with the header D segment. Consequently, the flow in the two cells are equal only if the pressure drop across the header D segment ( $D_i D_o$ ) is negligible with respect to the pressure drop across the cells ( $C_i D_o$  and  $C_i D_i$ ) which have by construction the same hydraulic impedance.

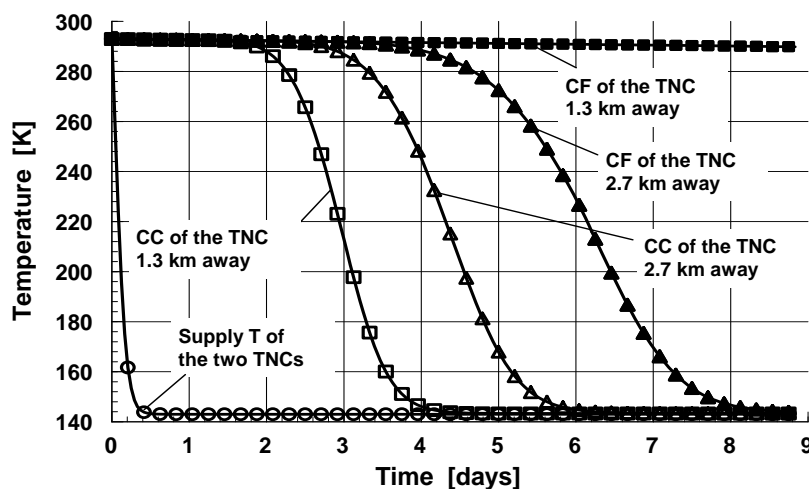


**FIGURE 5.** Local flow scheme of two neighboring standard cells supplied by one valve.

To study the unbalanced cooling, a numerical simulation based on the model shown in FIGURE 5 was done, in which two TNCs at different positions (1.3 km and 2.7 km away from refrigerator respectively with the total flow of 500 g/s for the whole sector) were investigated. The different input conditions for the two pairs of cells is given by the mass-flow rates in the header D. As the return helium is progressively collected in header D, the pair of cells closer to the refrigerator has a higher flow rate. FIGURE 7 shows the simulation results which are in agreement with the phenomenon observed during the cool-down. The cool-down of CCs is faster and the unbalanced effect in the TNC closer to the refrigerator is more severe.



**FIGURE 6.** Measured unbalance phenomenon during the first cool-down.



**FIGURE 7.** Simulated unbalance phenomenon during the first cool-down of sector 7-8.

The distribution of mass flow rates between the two cells (CC and CF) were also simulated and presented in FIGURE 8. When the TNC is far from the refrigerator, the uniformity of mass flow rate distribution in CC and CF is improved. FIGURE 9 shows the evolution of the pressure drop in the CC cells (CiDo) and in the header D segment (DiDo) in two different TNCs. FIGURE 10 shows the corresponding pressure drop ratios. For the TNC close to the refrigerator, the ratio is about 1, i.e. the pressure drop of the header D segment is definitely not negligible and the unbalance is important. For the TNC far from the refrigerator, a ratio of about 3 reduces but does not suppress the unbalance effect.

In conclusion, the main explanation for the unbalanced cool-down of a TNC is the frictional pressure drop along the header D which is not negligible with respect to the frictional pressure drop of the cells.

The numerical simulation shows also that it is possible to obtain a pressure ratio below 1. In this case, the Di pressure is higher than in the Ci producing a back-flow in the CF cell. This back-flow effect, which produces a partial warm-up of the CF cell, has also been observed during the cool-down.

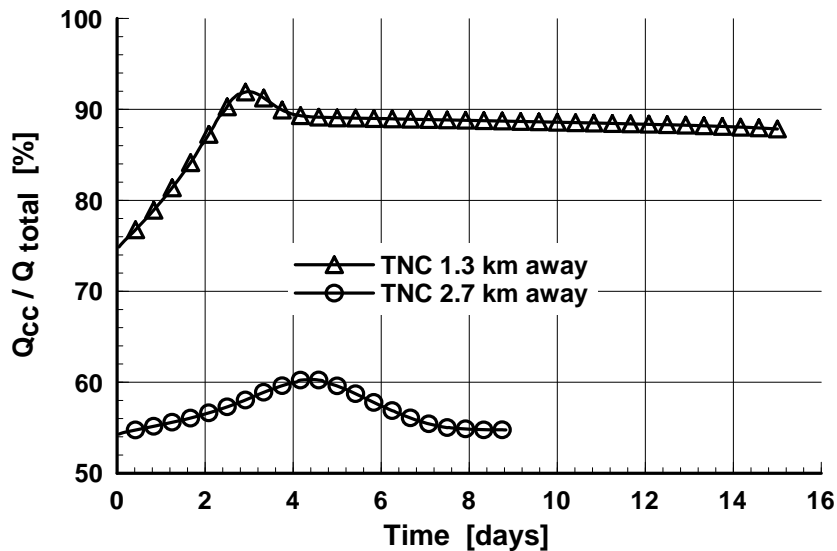


FIGURE 8. Distribution of mass-flow rates in TNCs at different distances from the refrigerator.

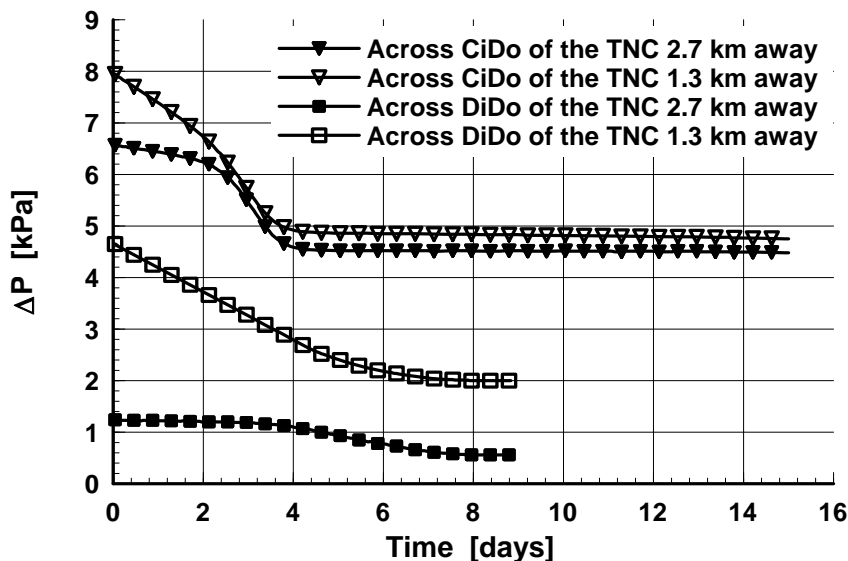


FIGURE 9. Evolution of pressure drops of TNCs at different distances from the refrigerator.

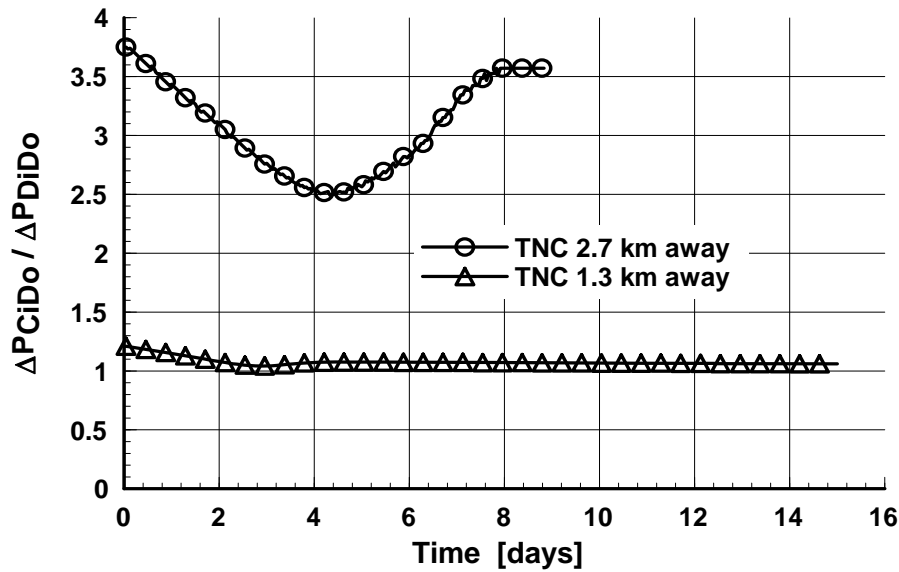
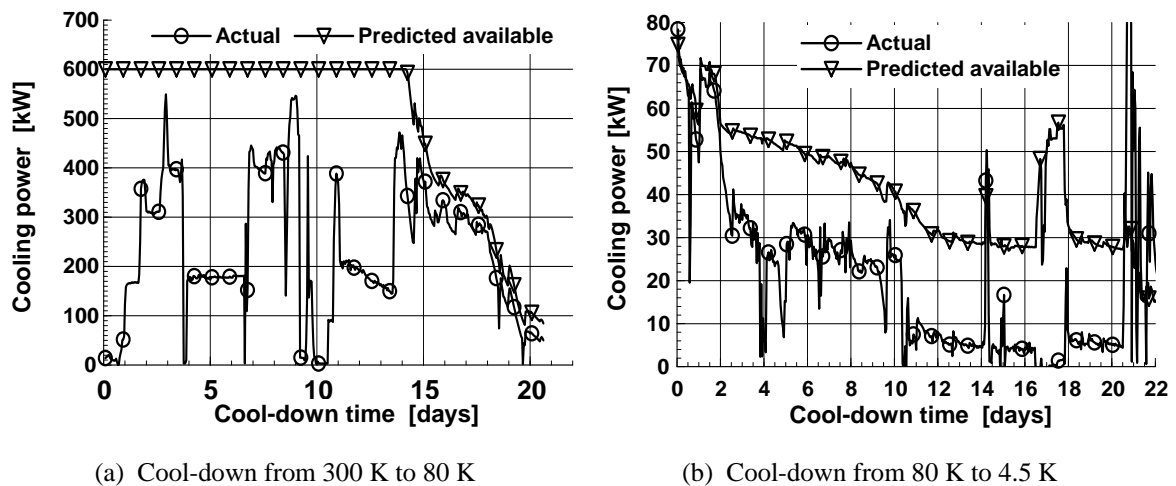


FIGURE 10. Evolution of pressure-drop ratio of TNCs at different distances from the refrigerator.

## UNDERSTANDING LONGER COOL-DOWN TIME

The first cool-down of sector 7-8 has taken more time than predicted, especially for the cool-down phase from 80 K to 4.5 K. As shown in FIGURES 2 and 3, more than 20 days were necessary to cool down the sector from 300 K to 80 K (about 10 days were predicted) and about 22 days (the actual valid period is at about 16 days) from 80 K to 4.5 K (about 5 days were predicted).

The main reason is that the actual cooling power was smaller than the predicted one. The measured actual cooling power and predicted available cooling power are compared and shown in FIGURE 11. The actual cooling power is obtained by enthalpy difference calculations based on the measurements of supply and return conditions (temperature and pressure) and mass-flow rate varying with time. The predicted available cooling power is defined by the maximum cooling power which can be delivered by the refrigerator depending on the measured return temperature. The average of the actual cooling power is only about half of the predicted available one for the first phase and much lower for the second phase.

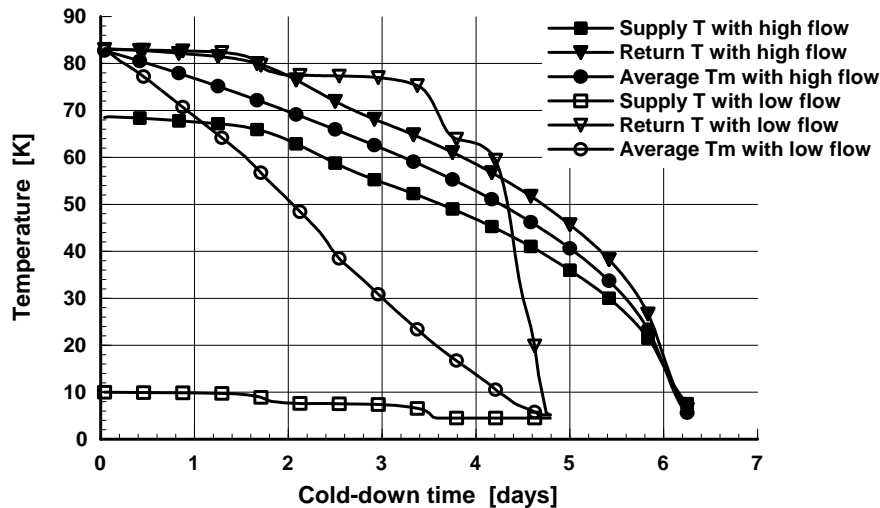


(a) Cool-down from 300 K to 80 K

(b) Cool-down from 80 K to 4.5 K

FIGURE 11. Actual and predicted available cooling powers of the first cool-down.





**FIGURE 12.** Cool-down from 80 K to 4.5 K using the predicted available cooling power.

In addition, for a given cooling power, the cool-down from 80 K to 4.5 K can be done by applying (as for this first cool-down) high flow and small temperature differences or by reducing the flow and using higher temperature differences. FIGURE 12 gives the calculated cool-down time from 80 K to 4.5 K using the predicted available cooling power for high- and low-flow configurations. By using lower flow and larger temperature differences, the cool-down time can be reduced by 25%. This is explained by the fact that with lower flow, the cold front entering the cells takes more time to reach the cell outlet and consequently, the return temperature stays at a higher value during a longer time. As the cooling power increases with the return temperature, the available cooling power remains at a higher value during all this time and accelerates the cool-time time.

## CONCLUSIONS

The first cool-down of the first LHC sector (Sector 7-8) has been analyzed, simulated and compared with the predicted generic cool-down. The mathematical model simulating the cool-down of a LHC sector is basically in accordance with the measurement; the difference on the average temperature is less than 5% and on the total cool-down time less than 3%. Unbalanced cool-down effect on two neighboring cells supplied by one valve has been observed, simulated and explained by the significant pressure drop in the return header; a new control strategy has been proposed and implemented to cope with this effect. With respect to the predicted generic cool-down, a longer cool-down time has been observed and explained mainly by the reduced cooling power used during this first cool-down, and also by the set-up of the total mass flow transporting the cooling power.

## REFERENCES

1. Millet, F. *et al.*, "Commissioning the Cryogenic System of the First LHC Sector," *paper presented at this conference*.
2. Serio, L. *et al.*, "Validation and Performance of the LHC Cryogenic System through Commissioning of the First Sector," *paper presented at this conference*.
3. Liu, L., Riddone, G., Taviani, L., "Numerical Analysis of Cool-down and Warm-up for the Large Hadron Collider," *Cryogenics*, 43(6): pp. 359-367 (2003).