

# Implementation and performance of the Detector Control System for the electromagnetic calorimeter of the CMS experiment

P. Adzic<sup>1</sup>, A. Brett<sup>2</sup>, F. Cavallari<sup>3</sup>, D. Di Calafiori<sup>4</sup>, G. Dissertori<sup>2</sup>, R. Gomez-Reino<sup>5</sup>, A. Inyakin<sup>6</sup>, D. Jovanovic<sup>7,1</sup>, G. Leshev<sup>2</sup>, P. Milenovic<sup>2,1</sup>, R. Ofierzynski<sup>5</sup>, T. Punz<sup>2</sup>, J. Puzovic<sup>7,1</sup>, S. Zelepoukine<sup>8,2</sup>

<sup>1</sup>VINCA Institute, Belgrade, Serbia; <sup>2</sup>ETH Zurich, Switzerland; <sup>3</sup>INFN, Rome, Italy;  
<sup>4</sup>CEFET/RJ, Rio de Janeiro, Brazil; <sup>5</sup>CERN, Geneva, Switzerland; <sup>6</sup>University of Minnesota, USA;  
<sup>7</sup>Faculty of Physics, University of Belgrade, Serbia; <sup>8</sup>IHEP, Protvino, Russia;

[Predrag.Milenovic@cern.ch](mailto:Predrag.Milenovic@cern.ch)

## Abstract

In this presentation we describe the main design objectives, the detailed specifications and the final layout of the Detector Control System (DCS) for the electromagnetic calorimeter (ECAL) of the CMS experiment. Emphasis is put on the system implementation and specific hardware and software solutions in each of its sub-systems. The latest results from the tests of final prototypes of these subsystems during the 2006 ECAL test-beam programme, as well as the installation and commissioning of the whole DCS at the CMS experimental construction site are discussed.

## I. INTRODUCTION

The Compact Muon Solenoid (CMS) experiment is one of the two large multi-purpose detectors at CERN's Large Hadron Collider (LHC) [1]. CMS is presently in the final phase of construction work at Point 5 near Cessy (France) and shall be ready for data taking in the first half of 2008. One of the most accurate, distinctive and important detector systems of the CMS experiment is the high precision Electromagnetic Calorimeter (ECAL). It will provide measurements of electrons and photons with an excellent energy resolution (better than 0.5% at energies above 100 GeV [2]), and thus will be essential in the search for new physics, in particular for the postulated Higgs boson.

In order to successfully achieve these physics goals the ECAL collaboration has designed the calorimeter as a homogeneous hermetic detector based on 75848 Lead-tungstate (PbWO<sub>4</sub>) scintillating crystals. Avalanche Photo Diodes (APD) and vacuum phototriodes (VPT) are used as photodetectors in the barrel part and in the end-cap parts of the detector, respectively [2]. All these components and front-end (FE) readout electronics inside the ECAL satisfy rigorous design requirements in terms of their response time, signal-to-noise ratio, immunity to high values of the magnetic field (up to 4T in the barrel part of the ECAL) as well as in terms of radiation tolerance (expected equivalent doses of up to 50 kGy and neutron fluence of up to 10<sup>14</sup> neutrons/cm<sup>2</sup>) [2]. However, the light yield of PbWO<sub>4</sub> crystals and the amplification of the APDs is rather sensitive to temperature and bias voltage fluctuations [3, 4]. Therefore, the use of these components has directly imposed challenging constraints on the design of the ECAL, such as the need for rigorous temperature and high voltage stability. At the same time, mechanisms that allow radiation to induce changes in crystal transparency (and hence in its response), imposed additional requirements for "in situ" monitoring of the crystal

transparency [2]. For all these reasons specific ECAL sub-systems that provide the necessary services had to be designed. These include: Cooling system [5], High Voltage (HV) and Low Voltage (LV) systems [6,7], as well as Laser Monitoring system [8]. In addition, a sophisticated ECAL Detector Control System (DCS) that could provide the necessary control and monitoring of the proper functioning of all these ECAL sub-systems, as well as the control and monitoring of important ECAL working parameters, had to be carefully designed.

## II. HIGH VOLTAGE, LOW VOLTAGE AND COOLING SYSTEM

The APDs require a power supply system with a stability of the bias voltage of the order of few tens of mV. For this reason, a custom HV power supply system has been designed for the CMS ECAL in collaboration with the CAEN Company [6]. The system is based on a standard control crate (SY1527) hosting eight boards especially designed for this application (A1520PE). Up to nine channels can be hosted on a single A1520PE board and each channel can give a bias voltage of up to 500 V with a maximum current of 15 mA. The operating APD gain of 50 requires a voltage between 340 and 430 V. In total, there are 18 crates and 144 boards. Every SY1527 crate communicates with a board controller via an internal bus and is operated by the ECAL DCS via an OPC server.

The ECAL digitization electronics located on the very front-end (VFE) electronics cards require also a very stable low voltage to maintain constant signal amplification. The system uses low voltage regulators that guarantee this stability. The power is supplied by the LV system that is based on multichannel MARATON LV power supplies (PS) from Wiener [7]. Two types of LV PS are used: a type with six channels of 8V/110A (660 W) and a type with five channels of 8V/110A (660 W) and two channels of 8V/55A (330 W). In total there are 108 PSs for the ECAL barrel and 28 PSs for the ECAL end-cap. All the LV PSs are water-cooled and operated by three ECAL DCS PCs via CAN-bus via an OPC server.

The ECAL Cooling system employs the water flow to stabilise the detector to 18 °C within 0.05 °C. Each Supermodule and each End-cap is independently supplied with water at 18 °C. The water runs through a thermal screen placed in front of the crystals which thermally decouples them from the silicon tracker, and through pipes embedded in the aluminium grid in front of the electronics compartments. Regulation of the water temperature and the water flow, as well as the opening of valves is performed by a dedicated

Siemens PLC system. This system is operated by a PC via S7 connection and monitored by the ECAL DCS.

### III. DESIGN OF THE ECAL DCS

The ECAL DCS [9] has been designed to provide several functionalities. Its first functionality is the autonomous monitoring of various kinds of the detector environmental parameters, such as the temperature of the thermal shielding of ECAL crystals and APDs, the humidity and temperature of the air inside the electronics compartments of the Supermodules (SM), and the presence of water leakage inside the SMs. Its second functionality is the monitoring of the running conditions of on-detector electronics (values of on-board temperatures, APD leakage currents and electronics

VPTs and on the VFE boards, leakage currents of the APDs and the output voltages on the low voltage regulators).

The other part of the functionalities is implemented via dedicated DCS applications whose readout systems are completely independent from the ECAL DAQ. These are the ECAL Precision Temperature and Humidity Monitoring system (PTM/HM) and the ECAL Safety System (ESS). Detailed descriptions of sensors, implemented readout electronics and communication protocols used by these systems are presented in the following sections.

One of the main challenges for the ECAL DCS is a large number of channels and parameters that need to be monitored – approximately 120'000 in total. On the other hand, expected raw data rates of 10 MB/h and data archiving rates of 1.5

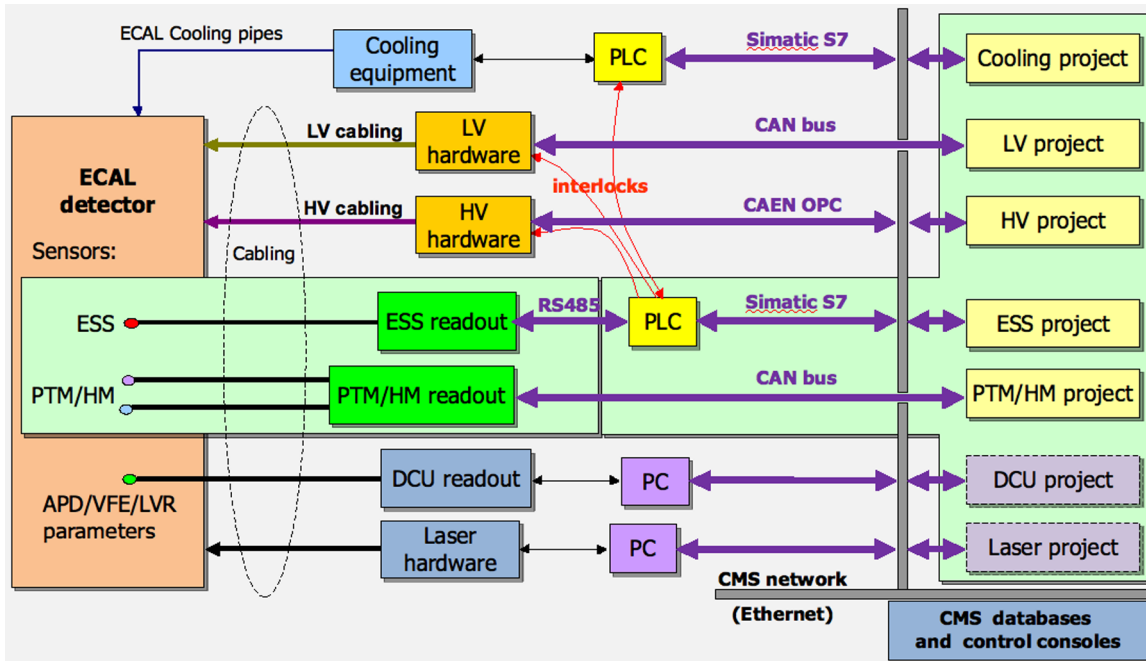

Figure 1: ECAL DCS layout

bias voltages), as well as the monitoring and control of the parameterisation and running of all ECAL subsystems (HV, LV, Cooling and Laser monitoring systems). The third functionality of the ECAL DCS is to provide early detection of abnormal conditions, issue appropriate warnings and alarms, execute predefined control actions and trigger hard-wired interlocks to protect the detector and its electronics from severe damage. Regarding the control actions, the ECAL DCS is designed to provide switching on/off and ramping up/down of the HV and LV systems.

Parts of these DCS functionalities are implemented through software applications running on dedicated DCS computers, as is the case with the HV, LV, Cooling and Laser monitoring systems. These applications communicate to hardware or to embedded computers using industry standard networks or field-bus protocols (such as Simatic S7 connection via TCP/IP or OPC connection via CAN bus).

In the case of the monitoring of on-detector electronics, specific detector parameters are collected by dedicated ASICs (Detector Control Units, DCUs) on the VFE electronics and read out via the control rings of the data acquisition (DAQ) system, before being transferred to the databases and to the DCS. These parameters include: temperatures near the APDs,

GB/month are routinely manageable.

In the case of the ECAL DCS hardware, further specific challenges are added to the one mentioned above: the sensors of PTM/HM and ESS must be reliable and capable to operate accurately in the presence of high radiation fluxes (up to the total fluence of  $10^{14}$  neutrons/cm<sup>2</sup> over the CMS life cycle) and magnetic fields of 4 Tesla. In addition, since the readout electronics of these systems will be placed inside the CMS cavern, it must be radiation tolerant to appropriate doses and be designed in such a way that the long cable paths (50-100m) do not cause a deterioration of the measurement precision.

### IV. PRECISION TEMPERATURE MONITORING AND HUMIDITY MONITORING (PTM/HM)

The purpose of the PTM system is to provide precision temperature measurements and to monitor the stability of the temperature distribution in the environment of the ECAL crystals and photo-detectors. In addition, it should provide archiving of the temperature distribution history for use in the ECAL data processing.

In order to provide this functionality, 360 high quality NTC thermistors [10] with very good long-term stability are

installed in the ECAL Supermodules and 80 more are to be installed in the ECAL End-cap Dees. Sensors are individually pre-calibrated by the manufacturer and then tested and sorted in the lab to ensure a relative precision better than 0.01 °C.

The purpose of the HM system is to monitor the relative humidity (RH) of the air inside the ECAL electronics compartments and to provide early warnings about high humidity conditions that may potentially lead to water condensation inside the detector. There are 176 HM sensors with 5-7% RH precision [11] placed inside the ECAL.

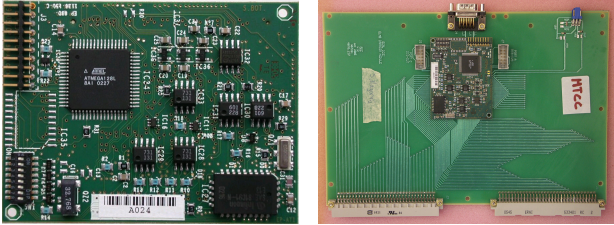

Figure 2: ELMB and PTM/HM electronic boards with ELMB

Both PTM and HM sensor samples were tested for their capability to work in an environment with high radiation levels and strong magnetic field that will be present in the ECAL region of CMS. Sensors have shown the ability to maintain their operational parameters unchanged during the expected running life time of the ECAL.

All PTM/HM sensor probes are connected to readout electronics with shielded twisted-pair cables, which are routed through the CMS detector to ECAL Supermodule/Dee patch panels. The cable lengths vary from 80 to 100 m.

The readout systems of both PTM and HM systems are based on ELMB modules designed by the ATLAS experiment [12]. The ELMB module is a compact plug-on card with one embedded high-precision 16-bit ADC, one 64 channel differential analogue input multiplexer, one ATMEL AVR RISC microprocessor and one CAN bus interface (Fig. 2, left). Each ELMB module is plugged on a specific PTM/HM electronic board that provides signal mapping/routing for 64 channels (Fig. 2, right). In addition, PTM is using a specifically designed circuit boards for thermistor excitation, while HM is using transmitters from the sensor manufacturer to excite the RH sensors and provide the conditioning of their signals (Fig. 3).

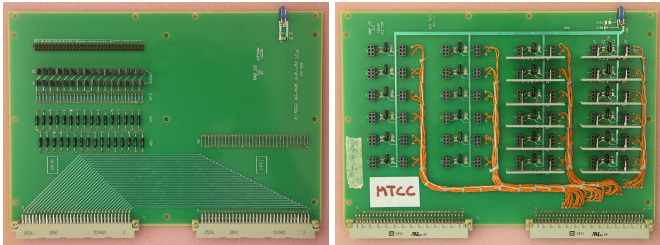

Figure 3: PTM/HM electronic boards for sensor excitation

The PTM/HM readout electronics is implemented on 6U-size boards that will be installed in PTM/HM standard 6U Euro-crates. The complete configuration comprises four crates installed in two “LHC standard” racks, accordingly to the ECAL “plus” and “minus” structuring. This configuration provides a readout system for 512 channels of the PTM and 192 channels of the HM system.

All PTM/HM readout electronics is located on the balcony in the CMS experimental cavern (UXC), outside the CMS

detector. The readout electronics has been successfully tested for the long-term operation in this environment [12]. The position of the PTM/HM outside CMS offers an additional advantage allowing easy access to the readout system for its maintenance and module replacement during CMS shut-down periods.

After the raw sensor signals are digitized with the ELMB's ADC, the data are sent by the ELMB's microcontroller via a CAN bus to the DCS PC hosting the PTM/HM application, which is located in the CMS service cavern (USC). All ELMBs located within the crates inside one rack are connected to a single multi-point CAN bus.

Low voltage DC power for the readout electronics at the PTM/HM crates (12 V, 5 V) is delivered from the USC. It is provided from a PTM/HM dedicated power supply unit in a way which provides galvanic isolation of all PTM/HM readout electronics from the ECAL detector.

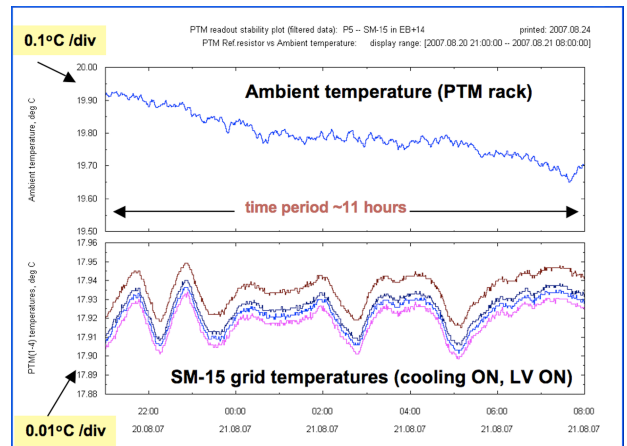

Figure 4: The PTM readout performance (SM-15)

The performance of the PTM readout system in terms of resolution and noise levels has proved to be outstanding. Temperature fluctuations from the noise introduced in the system are of the order of 0.001 °C in the range of 18 - 22 °C. An example of the performance of the PTM readout system, as well as of the stability of the cooling system connected to the SM-15 inside CMS at P5 is given in Fig. 4.

## V. ECAL SAFETY SYSTEM (ESS)

The purpose of the ESS [13] is to monitor the air temperature of the ECAL VFE and FE environment (expected to be in range the of 25 - 30 °C), to monitor water leakage sensors routed inside the electronics compartments, to control the proper functioning of the ECAL Cooling and LV Cooling systems and to automatically perform pre-defined safety actions and generate interlocks in case of any alarm situation.

In order to achieve these goals 352 EPCOS NTC thermistors [14] are positioned in redundant pairs at the centre of each module of the ECAL barrel SMs and at four locations inside each quadrant of the ECAL End-cap Dees. In accordance with the design objectives, the ESS temperature sensors are calibrated to a relative precision of 0.1°C.

The functionality of the water leakage detection has been based on commercial water leakage sensor-cables provided by RLE Technology [15]. Sensors are used in “2-wires connection” mode and terminated with an appropriate resistor. This configuration provides only information about the

presence of a water leak inside the system, but no information about the exact location.

The temperature and water leakage sensors of the ESS are read out by the front-end part of the ESS readout system, which comprises 12 ESS Readout Units (ESS RU) located in the CMS experimental cavern. Each ESS RU represents an electrically and logically independent entity that can support up to four ECAL SMs or up to two ECAL End-cap Dees.

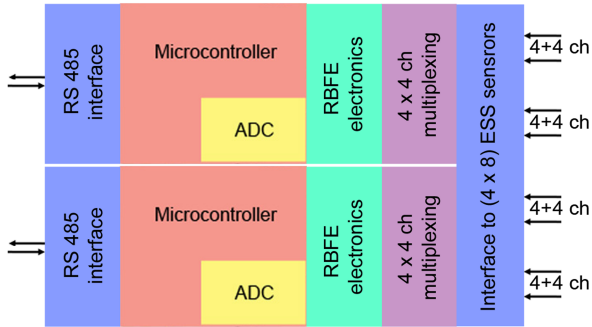

Figure 5: Block schematic of the readout system for the ESS temperature sensors

In order to provide a reliable and robust readout system, the ESS RUs have been designed in a completely redundant way. Each redundant part of one RU is equipped with a RS485 interface and based on a Microchip PIC microcontroller PIC18F452 and a so-called RBFE-MUX block of electronics. This block of electronics inside the ESS RU provides intelligent sensor information multiplexing, as well as the digital implementation of a resistance bridge (RBFE) for removal of different readout signal dependencies on voltage offsets, thermocouple effects, power supply and ambient temperature drifts etc. Information from the temperature sensors from four input ports of one RU is mixed between its two redundant parts in a way which minimizes the possibility of losing temperature information inside the ECAL due to malfunction of an ESS RU component. The block schematic of the ESS RU for temperature readout is shown in Fig. 5.



Figure 6: Photograph of the ESS installed and running in the ECAL Integration Area

The part of the system where sensor information is processed and interlocks are accepted/generated is based on the industrial Siemens Programmable Logic Controllers

(PLCs), according to the general CERN policy for detector safety systems. The ESS PLC system has been designed and built as a redundant and distributed set of modules from the S7-400 and S7-300 families (Fig. 6).

The ESS has been designed in such a way that the ESS RUs and ESS PLC system communicate and exchange sensor data and control information continuously. Since one of the main objectives of the ESS is a very high degree of reliability, a specific ESS multi-point communication protocol that provides reliable information exchange between ESS RUs and ESS PLC had to be designed. The design of the ESS protocol has been based on parts of international IEC standards for telecontrol protocols (such as “EIA RS-485:1983”, “UART FT 1.2”, “IEC 870-5-1” and “IEC 870-5-2”).

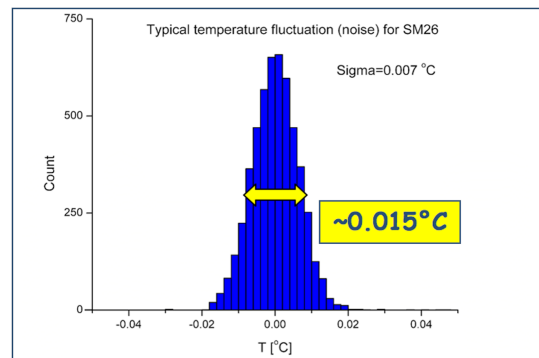

Figure 7: Performance of the ESS readout system (SM-26)

In addition, ESS also comprises 10 ESS Interlock Units (ESS IU) whose purpose is the distribution of interlock signals generated by the ESS PLC to and from different subsystems of the whole ECAL.

Both ESS sensors and electronics components of ESS RUs were tested for radiation tolerance to appropriate doses. ESS sensors were irradiated to the equivalent cumulative dose of about 200 kGy and fluence  $3 \times 10^{14}$  neutrons/cm<sup>2</sup>, while ESS readout system components were irradiated to the equivalent dose of about 60 Gy and fluence  $9 \times 10^{10}$  neutrons/cm<sup>2</sup>. Both temperature sensors and the readout electronics showed no shift in any parameter, while the cross section for single-event effects has proved to be negligible [13].

The ESS performance has been thoroughly tested during the ECAL integration, test-beam and calibration periods in 2006 and 2007, as well as during the ECAL SM insertion campaign in the first half of this year. The system has shown excellent reliability. At the same time, its temperature readout system has shown to have a relative precision better than 0.02 °C. Figure 7 shows, as an example of the ESS performance, the level of temperature fluctuations (noise) in the readout system of the ESS at Point 5 during insertion of the SM-26.

## VI. ECAL DCS SOFTWARE

In accordance with an official recommendation of the appropriate CERN LHC groups, all ECAL DCS applications have been developed using the commercial ETM SCADA (Supervisory Control And Data Acquisition) software PVSS 3.6 [16] and standard Joint Control Project (JCOP) framework components [17].

The heart of each control system at the LHC is a Finite State Machine (FSM) toolkit written in SMI++, a derivative of the former DELPHI controls software. The FSM enables a

high level of abstraction and simplified representation of detector control systems by introducing a finite set of well defined states, in which each of its subsystems can be, and rules that govern transitions between these states. The FSM states of each subsystem depend on the current status of the underlying hardware. At the same time, the FSM enables logical grouping of DCS subsystems into a hierarchical tree-like structure, where “parent” states are uniquely determined by states of its children and system-specific logic. Each parent in such a FSM tree can issue an action command to its children. Action commands at the lowest level imply appropriate commands of the control software to the hardware that is controlled by that software.

The CMS ECAL controls software has also been implemented in this way. The software granularity is driven by the ECAL subsystem structure. The HV, LV, Cooling, PTM/HM and ESS systems are controlled by independent applications. On top of these applications, there is the ECAL Supervisory application that implements FSM hierarchical structuring of the whole ECAL controls software. One of the advantages of this implementation is the minimization of human failures, as well as better overview for operators and for subsystem experts of the status of their subsystems.

In addition, the ECAL DCS applications include numerous other functionalities. These include: full parameterization and visualization of each subsystem, archiving of all relevant data to the CMS Conditions (ORACLE) database, as well as loading from and storing to the CMS Configuration (ORACLE) database the start-up and operational parameters for all DCS subsystems. The ECAL group has also developed a tool for an automatic JCOP framework component installation and configuration. This tool makes it easy to maintain the cluster of ECAL DCS computers and minimizes the downtime of CMS after serious data losses on these PCs. The information needed to restore systems is provided by datasets inside the CMS Configuration DB.

## VII. STATUS AND PLANS

The ECAL DCS has been providing support to several ECAL test setups in the last few years. It has been supporting the running of ECAL Supermodules during their final assembly at the ECAL electronics integration centre, during their testing and calibration with test-beam and cosmic rays at the H4 and H2 zones, as well as during the joint CMS Magnet Test and Cosmic Challenge that has been performed in 2006 at Point 5.

All these ECAL setups have also served the ECAL DCS as perfect benchmarking setups for the performance of both hardware and software prototypes of its subsystems. In that way, these setups have allowed the development of the ECAL DCS to the full-scale system capable to efficiently support the whole ECAL.

At this moment, the hardware commissioning of the whole ECAL DCS is close to its final phase. The complete hardware of the ESS is installed in both UXC and USC and most of the interlocks have already been interconnected and tested. The PTM/HM hardware is under test and calibration in the lab and will be moved to its final location soon. The hardware commissioning of these systems is expected to be finished as soon as the cabling of the ECAL has been completed.

After the commissioning of the ECAL DCS hardware has been completed, the ECAL DCS software applications will be tested and finely tuned with the final “production” ECAL subsystems at Point 5. After finishing both hardware and software commissioning, the ECAL DCS will enter its “routine” operational phase – for the next decade.

## VIII. REFERENCES

- [1] CMS Collaboration, “The Compact Muon Solenoid Technical Proposal”, CERN/LHCC 94-38 (1994).
- [2] CMS Collaboration, “The Electromagnetic Calorimeter Technical Design Report”, CERN/LHCC 97-33 (1977).
- [3] A.A. Annenkov, P. Lecoq and M.V. Korzhik: “Lead Tungstate scintillation material”, NIM A490 (2002) 30.
- [4] Z. Antunovic et al.: “Radiation hard avalanche photodiodes for the CMS detector”, NIM A537 (2005) 379.
- [5] I. Baillon et al., “Design and performance of the cooling system for the electromagnetic calorimeter of CMS”, Proceedings of 2004 IEEE Instrumentation and Measurement Technology Conference, Como, Italy, CMS CR-2004/030.
- [6] A. Bartoloni, “The power supply system for the CMS-ECAL APDs”, Proceedings of 7<sup>th</sup> Workshop on Electronics for LHC Experiments LEB 2001, Stockholm, Sweden, CERN-2001-005 (2001), 358.
- [7] WIENER MARATON highest density Power Supply for Hostile Environment, <http://www.wiener-d.com/M/22/51.html>
- [8] L. Zhang et al., “Performance of the Monitoring Light Source for the CMS Lead Tungstate Crystal Calorimeter”, CMS-CR 2005/001 (2005), Geneva, Switzerland, 2005.
- [9] G. Dissertori et al., CMS ECAL Sub-Project Specification, Detector Control System (DCS), <http://www.weth.cern.ch/dcs/>.
- [10] NTC thermistors 100K61A from Betatherm, <http://www.betatherm.com/>
- [11] RH sensors UPS-600 from Ohmic instruments, <http://www.cweb5.com/ohmic/>
- [12] B. Hallgren et al., The Embedded Local Monitor Board (ELMB) in the LHC Front-end I/O Control System, presented at the 7th Workshop on Electronics for LHC Experiments, Stockholm, Sweden, September 2001.
- [13] P. Milenovic et al., “Performance of the CMS ECAL safety system for Super Modules SM0 and SM1”, Nucl. Instrum. Meth. A **554** (2005) 427.
- [14] EPCOS AG, NTC thermistor 470Ω@25°C, ordering code B57211V2471J060, <http://www.epcos.com/>
- [15] RLE's patented Water Leak Detection Cable (SC), <http://www.rletech.com/products/cable.html>
- [16] ETM professional control: PVSS (Prozess Visualisierung und Steuerungs System) SCADA tool, <http://itcobe.web.cern.ch/itcobe/Services/Pvss/welcome.html>.
- [17] M. Beharrell et al., Technology Integration in the LHC experiments' Joint COntrols Project, CHEP'01, Beijing, September 2001. <http://cern.ch/itco/Projects-Services/JCOP/>.