

EUROPEAN ORGANISATION FOR NUCLEAR RESEARCH
CERN – A&B DEPARTMENT

AB-Note-2008-011 ABP

**ACTIVE LONGITUDINAL PAINTING FOR THE H⁻ CHARGE
EXCHANGE INJECTION OF THE LINAC4 BEAM
INTO THE PS BOOSTER**

C. Carli, R. Garoby

Abstract

Linac4 will provide 160 MeV H⁻ to the PS Booster synchrotron. The H⁻ beam will be injected by charge exchange injection allowing injecting several times into the same volumes of phase space. Thus, a large number of turns can be injected with high efficiencies and “painting” in order to shape the initial particle distribution for optimum performance becomes possible. In particular, a chopper makes longitudinal painting possible in addition to painting in transverse phase spaces. The slow synchrotron motion in the PS Booster implies an active longitudinal painting scheme, where the Linac4 output energy is modulated. Several active longitudinal painting schemes are presented. One scheme, based on a triangular Linac energy modulation, is proposed for the PS Booster H⁻ injection with Linac4.

1 Introduction

Linac 4 is a proposed linear accelerator [1] aiming at providing 160 MeV H^- to the PS Booster synchrotron. The main motivation is (i) to improve the performance of the PS Booster mainly by increasing the injection energy and (ii) to replace the ageing Linac 2.

The H^- beam will be injected into the PS Booster by charge exchange injection. This allows (avoiding a basic restriction for conventional multiturn injection from Liouville's theorem) injecting several times into the same volumes of phase space and, thus, to inject a large number of turns with very high efficiencies close to 100%: losses on the injection septum intrinsic for standard multiturn injection do not exist, whereas some losses occur due to neutral H after the stripper and protons ending up outside the acceptances. With H^- injection schemes, painting in order to shape the initial particle distribution for optimum performance becomes possible. In particular, a chopper makes longitudinal painting possible in addition to painting in transverse phase spaces.

Studies on longitudinal painting schemes for the PS Booster injection with Linac 4 are presented. Some implications on transverse aspects of the planned PSB H^- injection are sketched.

2 Basic considerations

2.1 Present PSB injection

At present, a proton beam with an energy of 50 MeV is injected into the PS Booster with a conventional multiturn injection with betatron stacking. Losses in the order of 30% to 40% (with a significant improvement due to a new injection line optics [4]) caused mainly by protons hitting the injection septum are inherent to the injection process.

The beam from Linac 2 is continuous (no chopper available) and, after injection the whole circumference of the PSB is filled with beam (exception: special cases, where very short pieces of the Linac pulse are injected and fill only a fraction of a Booster ring). Then, this continuous beam is captured relatively quickly within ~ 1 ms (due to lack of time and injection onto a slow ramp) introducing various perturbations due to non-adiabaticity.

The main performance limitation [2,3] of the PS Booster for high intensity and high brilliance beams is the effect of direct space charge forces characterized by the direct space charge (so called Laslett) tune shift ΔQ , which may, for the highest intensities, exceed $\Delta Q_v = -0.5$ in the vertical phase space. A second harmonic RF system is mandatory for best performance by increasing the bunching factor (defined as the ration between mean beam current divided by the peak current) in order to reduce the direct space charge tune shift. Empirical optimization led to the conclusion [5] that a surprisingly large voltage (about 8 kV, i.e. the same voltage than the one provided by the fundamental $h=1$ system) of the second harmonic $h=2$ RF system leads to best performance. This may be related to the fact that, after capture, the core of the bunch is much denser than outer regions or may indicate other phenomena not yet taken into account.

The beam is injected onto a slow ramp corresponding to a time derivative of the beam rigidity $d(B\rho)/dt \sim 5.0$ Tm/s.

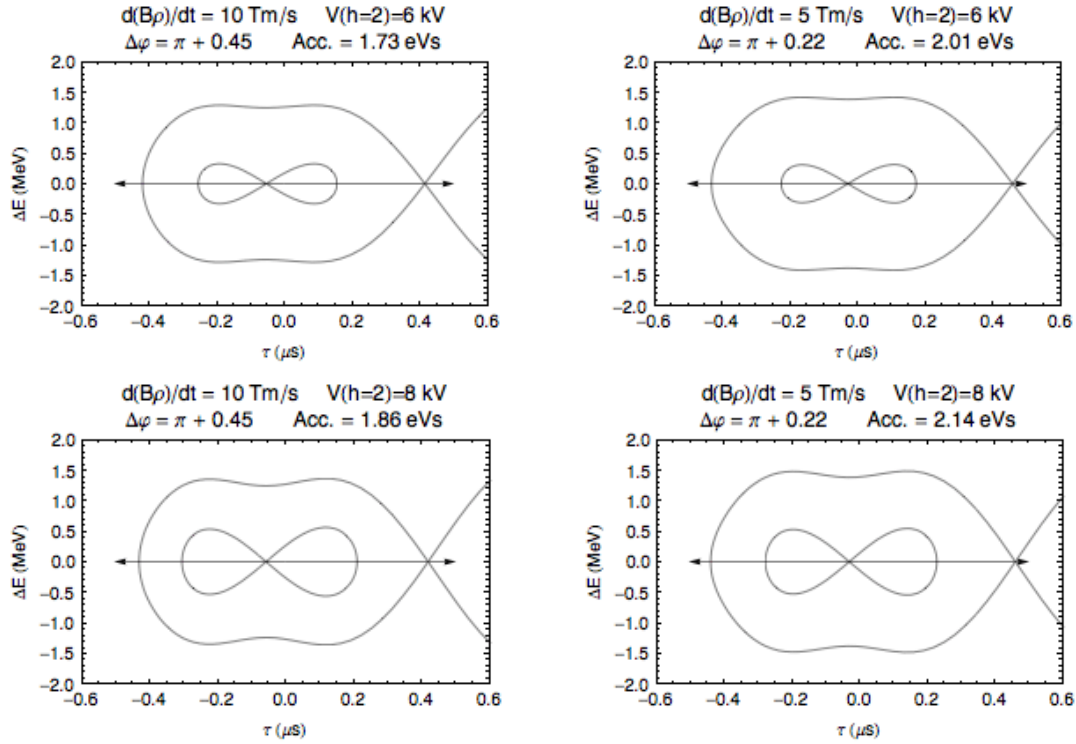

Figure 1: RF buckets in the PS Booster at 160 MeV neglecting direct space charge and for different ramp rates and voltages. The bucket obtained with parameters assumed for injection painting simulations described below is the one in the upper left corner with a ramp rate of $d(B\rho)/dt = 10.0$ Tm/s and a voltage of the second harmonic of $V(h=2) = 6$ kV.

2.2 PSB charge exchange injection with Linac 4

It is assumed that the PS Booster will be operated at low energy with harmonic number $h=1$ and with ramp rates similar to the ones at present. The H's provided by Linac 4 have a kinetic energy of 160 MeV corresponding to relativistic factors $\beta_{rel} = 0.520$ and $\gamma_{rel} = 1.17$. The following basic assumptions aim at minimizing the effect of the direct space charge by (i) obtaining a large bunching factor and (ii) minimizing the time spent at low energy:

- The beam is injected into waiting buckets (i.e. the RF system is already switched on prior to the injection) and onto a moderate ramp with a time derivative of the beam rigidity $d(B\rho)/dt \sim 10.0$ Tm/s. This ramp rate is about the one of the present PSB cycle at an energy of 160 MeV. Since no bunching takes place any more, there are no restriction on the ramp rate at injection.
- The double harmonic RF system will be used with the available maximum voltage for the fundamental $h=1$ system and an appropriate voltage for the second harmonic system. With the moderate ramp rate, this leads to a small "synchronous phase" and, in turn, to a large bucket extending along the major part of the circumference. In this report, RF voltages of $V_{h=1} = 8$ kV and $V_{h=2} = 6$ kV are assumed. The relative phase between the two RF systems is 206° , i.e. the optimum delay (to obtain flat bunches) of the second harmonic RF system on a ramp is slightly larger than in the case of a plateau (180°). The buckets obtained under these and, for comparison, slightly different conditions are plotted in Fig. 1.

- The aim of any painting scheme is to fill most of the bucket with an as homogeneous phase space density as possible. Note that, in this case, the best bunching factor is obtained with a smaller voltage of the second harmonic RF system than for a bunch with a dense core.

An RF bucket obtained under the conditions outlined above is shown in the upper left image of Fig. 1. The kinetic energy is 160 MeV, the ring circumference 50π m and the relativistic gamma factor at transition $\gamma_{tr}=4.03$. The height of the bucket is about ± 1.3 MeV corresponding to a relative energy width of $\Delta E/E_{tot} = \pm 1.2 \cdot 10^{-3}$ and a relative momentum width $\Delta p/p = \pm 4.4 \cdot 10^{-3}$. Note that the large bucket height could be reduced by a larger fundamental harmonic number (e.g. $h=2$). This option has been discarded to simplify operations.

Any painting scheme aims at filling the given bucket with a homogenous density in order to obtain a large bunching factor. The injection is expected to last typically a few tens of turns per Booster ring (here 20 turns/ring are assumed for nominal LHC operation and up to ~ 100 turns/ring for high intensity beams). This number depends on the intensity needed, the Linac4 current and the chopping factor (i.e. the fraction of Linac4 bunches not removed at low energy by the chopper). Due to the low harmonic number and relatively low RF voltages, motion in the longitudinal phase space during the duration of a typical injection is small, but not negligible (a small increase of the harmonic number to $h=2$ would not significantly change the situation). Some consequences, related to the present PS Booster and basic choices outlined above, are:

- The synchrotron motion cannot be used to obtain longitudinal painting almost “for free” without any energy modulation. Schemes (see e.g. [6, 7]), where the injection lasts several synchrotron oscillations and the beam is smeared out over the whole bucket are excluded due to the long synchrotron period. Thus, energy modulation (i.e. a variation of the mean energy of the bunches delivered along the Linac4 pulse in a well defined manner) is needed to paint the bucket.
- The synchrotron motion cannot be neglected completely. Care has to be taken in order to avoid local increases and decreases of the phase space density due some motion during a slow painting.
- Shift of the magnetic field during injection due to injection on a ramp:
 - The whole bucket shifts in energy during the injection in one ring. With the ramp rate 10 Tm/s and a maximum duration of the injection of 100 turns/ring, the momentum of the synchronous particle changes by a maximum of $\Delta p_r = 100 \mu s (10 \text{ Tm/s}) e = 0.3 \text{ MeV}/c$. In turn, the change of the energy of the synchronous particle is $\Delta E_r = c \beta_{rel} \Delta p_r \sim 0.150 \text{ keV}$. This amount is smaller than but not negligible with respect to the bucket height. Active energy modulation, i.e. a system allowing pre-programming the mean energy versus time evolution (within reasonable constraints) would allow compensating the above shift of the synchronous energy by adding an appropriate correction (e.g. raising from -125 keV to 125 keV).
 - Ring to ring differences of the magnetic field are in the range up to $\mp (150 \mu s 10 \text{ Tm/s})/\rho_{PSB} = \mp 1.8 \text{ G}$ for the outer rings, with $\rho_{PSB} = 8.24 \text{ m}$ the bending radius of the PS Booster bending magnets. This corresponds, for fixed particle energy, to a horizontal position $\pm D (1.8 \text{ G})/(2311 \text{ G}) = \mp 1.1 \text{ mm}$ and, a revolution frequency offset of $\pm (1/\gamma_{tr}^2) (1.8 \text{ G})/(2311 \text{ G}) 1 \text{ MHz} = 46 \text{ Hz}$, where $D=-1.4 \text{ m}$ is the dispersion and γ_{tr} the relativistic γ factor at transition. These ring to ring differences of the magnetic field can be easily compensated by adjusting the RF frequency from ring to ring or, by the so-called Bdl windings (the maximum integrated strength of 0.184 Tm given in [8] corresponds to a field of $\sim 36 \text{ G}$) of the bending magnets. Orbit distortions due to two special bends, namely BR.BHZ151 and BR.BHZ162, without Bdl windings are negligible.

- Increase of the transverse emittances in case of dispersion mismatch: With the slightly pessimistic assumption that the beam has, after completed injection, a rectangular distribution in energy with a width equal to the full height of the bucket, one obtains an rms momentum spread of $\sigma_p/p = (\Delta p/p)/\sqrt{3} = 2.5 \cdot 10^{-3}$. Neglecting the additional effect of transverse painting, one would expect the following blow-up of the normalized rms emittances for a beam arriving at the PS Booster injection point with zero dispersion:
 - Lattice used at present in operation: With a horizontal tune of 4.28 (and depending only very slightly on the vertical tune in the range 4.35 to 5.50), one obtains at the location of the injection stripping foil a horizontal betatron function of $\beta_H = 5.5 \text{ m}$ and a dispersion of $D = -1.4 \text{ m}$. Neglecting the transverse injection painting and effects due to direct space charge forces, one naively expects an emittance blow-up of $\Delta \epsilon^* = (1/2) (\beta_{rel} \gamma_{rel}) (D \sigma_p/p)^2 / \beta_H = 0.7 \mu\text{m}$. More realistic simulations [12], taking into account realistic transverse painting, but not yet the effect due to direct space charge forces, gave a blow-up of this order of magnitude, but with some dependence of the details of the painting scheme. Simulations, taking direct space charge forces into account as well, are underway [13].
 - This blow-up due to dispersion mismatch has to be compared to the transverse emittances of high brilliance LHC type beams of $\epsilon^* = 2.5 \mu\text{m}$. In conclusion, the rms blow-up, if the beam arrives with zero dispersion is just acceptable and deserves further clarifications [13]. Note that a reduction of the dispersion mismatch by a factor 2 would already improve significantly (simplified formula not taking transverse painting into account gives a decrease of the blow-up by a factor 4).
- Energy loss in stripping foil: The choice of the injection foil has not yet been finalized. A typical candidate is a carbon foil with a thickness of $340 \mu\text{g}/\text{cm}^2$ ($2 \mu\text{m}$, $1.7 \text{ g}/\text{cm}^3$) [12]. The energy loss per foil traversal is estimated with standard procedures [9] to about $\Delta E = 1.5 \text{ keV}$. Even though protons hit the foil several times and the number of hits is not the same for every proton, this is sufficiently small with the respect to the bucket height and, thus, of no concern.

2.3 General Considerations on Painting, Energy Modulation Schemes and Energy Jitter

The Linac4 chopper is a mandatory ingredient for all schemes investigated here to remove Linac micro-bunches, which would not end up inside the PSB bucket. In some cases, which have not been studied in detail (see sinusoidal energy modulation below), it must be used in addition to modulate the average Linac 4 current by removing a few Linac4 bunches from time to time.

The energy modulation (mean energy versus time evolution) must be controlled very well. Otherwise, phase space density fluctuations would develop (e.g. higher phase space density would be obtained if the spacing in energy between successive injected turns is smaller than expected). Thus, the jitter of the Linac 4 output energy may be a fundamental limitation of any of the painting schemes presented here. In particular, the significance of the various contributions to the overall jitter has some impact:

- Pure pulse-to-pulse jitter: In case the mean energy changes from one pulse to the next, without any significant change of the energy along the Linac 4 pulse, one may hope that this jitter can be compensated by the PS Booster phase loop (detecting very soon that the energy of the beam arriving is higher or lower than expected and adjusting the RF frequency for the rest of the injection). Slow drifts (caused e.g. by temperature changes) of the Linac4 output energy are of less concern, since compensation by slow pulse-to-pulse feedback is possible. Note that pulse to pulse fluctuations of the PS Booster magnetic field give analogous effects.
- Slow reproducible and detectable evolution of the mean energy along the Linac 4 pulse: At present, one expects that slow reproducible jitter along the pulse is significant and generated by beam-loading and damped by the low level RF feedback loops. If such a perturbation due to beam loading is well reproducible and can be determined with sufficient precision (by

measurement or simulation), one might envisage compensating it by appropriate feedforward corrections implemented via the Linac4 low level RF system. If a freely programmable energy modulation system is available for active longitudinal painting, it could also be used to reduce a slow reproducible and detectable energy jitter.

- Fast microbunch to microbunch jitter: In case that the energy changes very quickly from one bunch to the next (without any correlation between close bunches), this jitter would have an effect similar to an increase of the energy spread. However, only a negligible contribution due to fast microbunch to microbunch jitter is expected.

Furthermore, the change of the synchronous energy during the injection is not negligible especially for long injections for high intensity beams. Such a (relatively slow) evolution of the synchronous energy could be compensated as well by an active energy modulation system.

The following energy modulation schemes have been envisaged:

- “Free-running” sinusoidal energy modulation: The initial idea has been that an additional cavity driven with a frequency slightly different from the fundamental frequency of Linac4 would generate a sinusoidal energy modulation. The amplitude of this modulation is given by the amplitude of the field in this additional RF cavity and the frequency of the modulation is given by the difference of the frequency of the modulation cavity and the fundamental Linac4 frequency. Note that with such a scheme, an elaborate modulation scheme of the Linac4 beam current is needed. One may envisage a scheme where from time to time a few Linac4 bunches are removed to reduce the average current where needed. Such a free-running scheme has been put aside temporarily for the following reasons:
 - Compatibility with debunching: If the energy modulation cavity would be placed immediately after the last Linac4 tank (where the bunches are short and, thus, such a cavity has negligible impact on the longitudinal bunch shape), the arrival time of the bunches at the debuncher would be modulated as well. In order to avoid that the debuncher removes a (major) part of the energy modulation applied, strong phase modulation would be needed. A single “free-running” energy modulation cavity (applying a voltage at least similar to the one of the debuncher to the beam) cannot be placed after the debuncher, since there the bunches are long. One may envisage installing two additional cavities with opposite slopes of the voltage waveform (and opposite frequency offsets with respect to the Linac 4 fundamental frequency). Even though the linear longitudinal focusing of the two cavities would cancel, nonlinear contributions are not favorable for beam dynamics aspects.
 - It is not possible to compensate neither reproducible slow energy jitter nor the change in synchronous energy in the PS Booster due to the ramp during the injection.
- Freely programmable energy modulation: One option to realize such a scheme is to adopt the Linac 3-LEIR scheme. Note that in practice the energy versus time evolution is dominated by a triangular shape (needed for painting, see below) with some additional contributions to compensate slow jitter and/or change of synchronous energy due to the ramp.
- Schemes with some kind of symmetric energy offset, by iteratively increasing and decreasing the beam energy of subsequent bunches with the help of a cavity running with half of the fundamental frequency of the Linac. An additional amplitude modulation is needed. Note that such a scheme does not allow compensating neither a reproducible slow energy jitter nor the change in PS Booster synchronous energy due to the ramp during the injection.

3 Triangular energy modulation

3.1 Principle

The principle of painting with triangular energy modulation is best explained with the help of Fig. 2. The time evolution of the mean energy is represented by the dot-dashed line. One notes that this time evolution has a triangular shape with a period of 20 PS Booster turns in this example. The beam is switched on only, if the mean energy falls inside a contour plotted as dashed line corresponding to a given fraction of the RF bucket (80% in the example). If the mean energy is

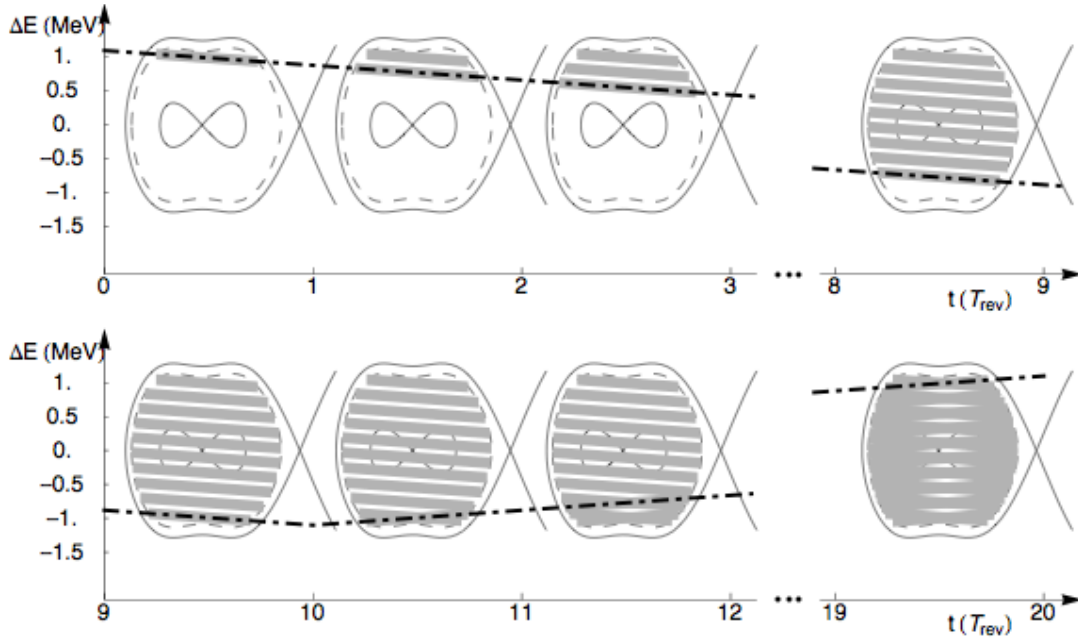

Figure 2: Principle of longitudinal painting with triangular energy modulation (neglecting synchrotron motion).

outside, the Linac4 bunches are removed with the help of the chopper. Due to the linear mean energy versus time evolution, the different turns are injected with a constant turn to turn offset. If, in addition, the energy width of the arriving particles is appropriate, most of the bucket is filled homogeneously. After 10 turns with steadily decreasing mean energy the whole bucket is filled once. During the next 10 turns the bucket is filled once more with the positive slope of the mean energy time evolution. Note that, during one scan (increasing or decreasing mean energy), the phase space density is slightly changed due to the synchrotron motion (e.g. in the head of the bunch the energy offset of subsequent injected turns is increased or decreased). However, the effect due to scans in opposite direction cancels.

Depending on the intensity needed, the injection in one PS Booster ring may last one or more energy modulation periods. In addition, the energy modulation period may have to be adjusted (lengthened) in order to inject the desired intensity with a multiple of this period.

During the injection of 20 turns with a total duration of $20.16 \mu\text{s}$ in the example, the beam is “on” during $12.54 \mu\text{s}$. Thus, the chopping factor (defined as ratio between times with beam on and total duration) is 62.2 %. If one aims at injecting the intensity for nominal LHC operation with Linac4 ($3.25 \cdot 10^{12}$ protons per ring allowing for losses further downstream [1]) during these 20 turns,

the peak current (during periods with beam on) needed is about 41 mA. Note that this peak current is lower than the present Linac4 design current (65 mA). The underlying reasons is to lengthen the injection in order to:

- Make the implementation of an energy modulation system more realistic. Any scheme for triangular energy modulation envisaged at present is demanding due to the large amplitude (~ 1.2 MeV) and short repetition period (20 μ s assumed here are more realistic than ~ 13 μ s from [1]).
- Better paint the 6D phase space volume to be filled during the injection. Note that there is not only painting in longitudinal phase space, but as well in both transverse phase spaces aiming finally at filling a volume in 6D phase space with suitable density distribution.

The maximum intensity required for ISOLDE operation (up to $16.0 \cdot 10^{12}$ protons per ring [1]) can be obtained by injecting with about the same Linac4 current during five energy modulation periods, each one lasting 20 PS Booster revolutions.

3.2 Simulations with ESME

In order to take direct space charge effects and, in particular, distortions of the bucket shape into account, simulations have been carried out with the code ESME [10]. Since the special particle distributions injected cannot be generated in a straightforward manner, initial distributions have been generated by a Mathematica program and provided on files. Two cases have been simulated:

- Nominal LHC beam (allowing for losses) with single batch filling of the PS, i.e. $3.25 \cdot 10^{12}$ protons injected during 20 turns/ring and one energy modulation period. The bucket height and energy offsets computed neglecting direct space charge have been used. The energy modulation amplitude was 1.1 MeV.
- Very high intensity beam for ISOLDE ($16.0 \cdot 10^{12}$ protons) injected during 100 turns and five energy modulation periods. A significant reduction of the bucket size due to direct space charge has been compensated by multiplying all momentum offsets by a constant factor 0.95/1.1 and, thus, the energy modulation amplitude reduced to 0.95 MeV.

For both cases, the simulations have been carried out for a total of 10^6 macro-particles and a total duration of 3000 turns (~ 3 ms). Parameters to compute the direct space charge forces (number of bins in longitudinal positions to estimate the density) have been adjusted carefully in order (i) to obtain sufficient resolution of the longitudinal density and direct space charge forces and, (ii) to be insensitive to numerical noise due to the limited number of macro-particles.

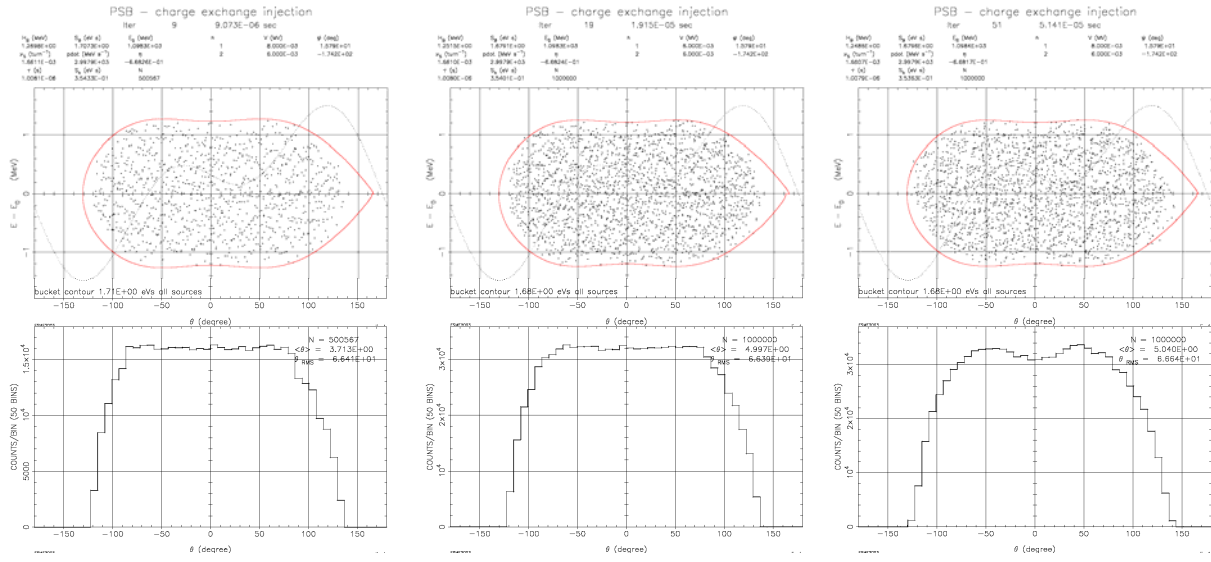

after 10 turns

after 20 turns
(injection completed)

after 52 turns

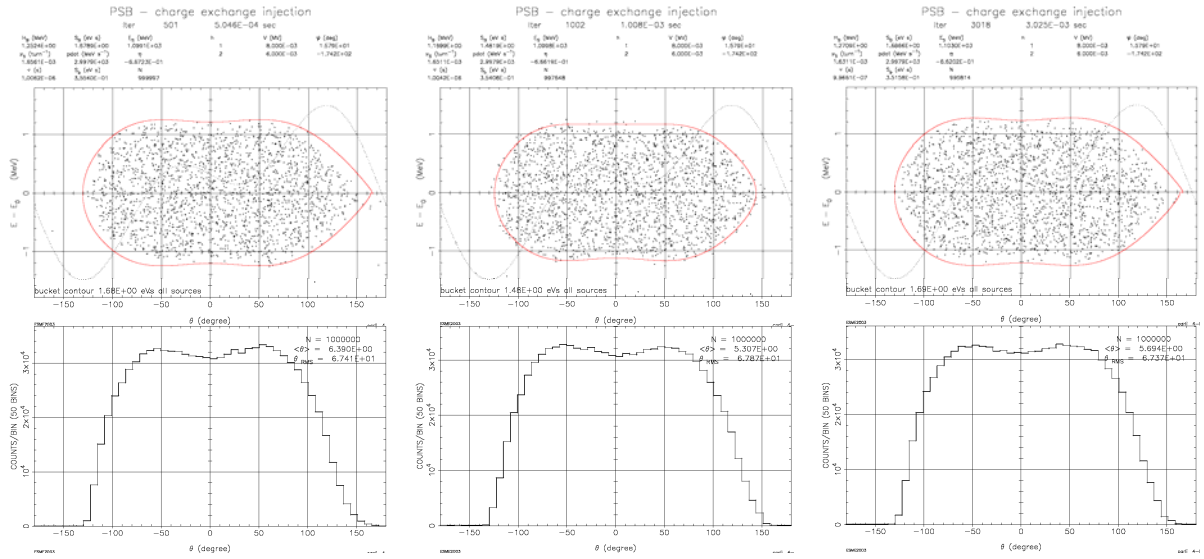

after ~500 turns

after ~1000 turns

after ~3000 turns

Figure 3: Simulation of injection painting with triangular energy modulation for a nominal LHC beam with single batch filling of the PS.

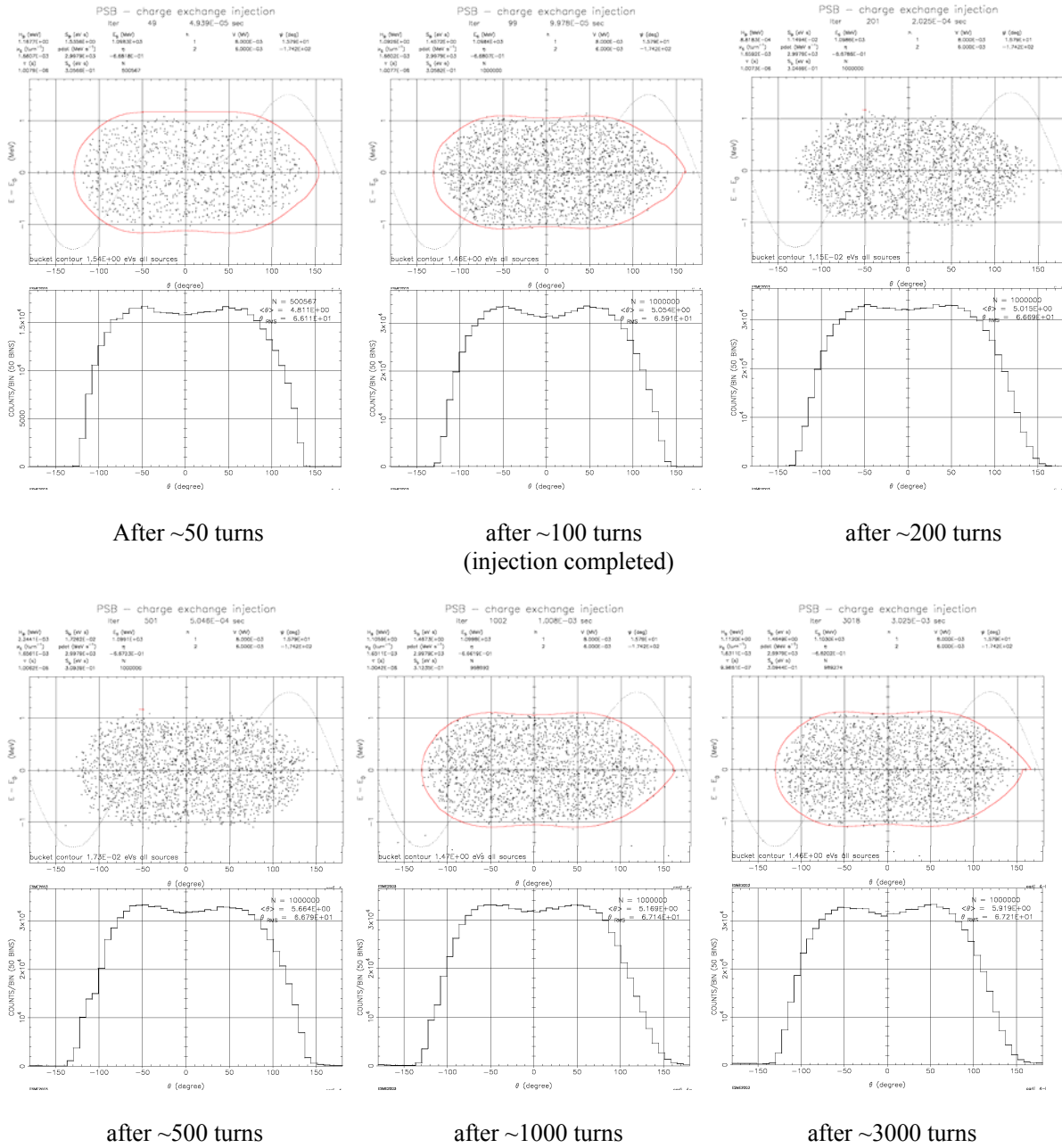

Figure 4: Simulation of longitudinal injection painting with triangular energy modulation for a very high intensity ($16 \cdot 10^{12}$ protons per ring) beam.

3.3 Results

Plots summarizing the simulation results for the nominal LHC beam and a very high intensity beam are shown in Figures 3 and 4, respectively. One notes:

- In both cases, about 99% of the injected particles remain in the simulation up to the very end.
- In both cases, the phase space is filled with good homogeneity and, thus, bunch shape fluctuations are small (but visible).
- The direct space charge forces reduce the bucket height (see Fig. 4) and render the leading and trailing edges of the bunch shape less steep for the high intensity beam.
- Typical bunching factors are around ~ 0.61 (lowest values due to beating ~ 0.60) for the nominal LHC beam. Slightly lower bunching factors are observed for the high intensity beam.

4 Symmetric Triangular Energy Modulation

4.1 Principle

The injection painting scheme proposed here is driven by considerations on the generation of the energy modulation. The underlying scheme is depicted in Fig. 6. An additional cavity installed in the transfer line runs with half the frequency of the linear accelerator, such that one out of two bunches is accelerated and one out of two bunches is decelerated. Disregarding the (in general high frequency) bunch structure of the linear accelerator, a superposition of beams with positive and negative energy offset is obtained. A debunching cavity cannot be placed downstream from such an energy modulation cavity, because bunches with positive and negative energy offset would pass with different phases due to different travel times between the cavities. Thus, the energy modulation cavity must be placed downstream from possible debunching cavities, i.e. at a location where partial debunching has already lengthened the bunches (condition for efficient reduction of the energy spread). However, non-linearities of the waveform are reduced due to the low frequency (half the fundamental Linac frequency). The energy modulation is created by amplitude modulation of this additional cavity and no phase modulation is needed. Drawbacks are that (i) an additional RF system running at half the fundamental frequency of the linear accelerator is needed, and (ii) if debunching is needed, the bunches will experience some non-linearities from the waveform.

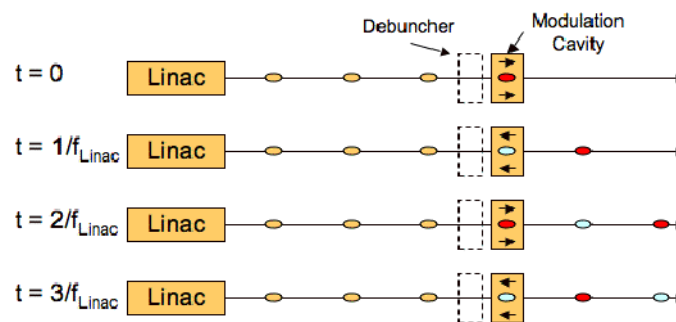

Figure 6: Principle for the generation of symmetric triangular energy modulation. A cavity running at half the fundamental frequency of the linear accelerator increases (plotted in dark red) and decreases (light blue) the energy of every second bunch.

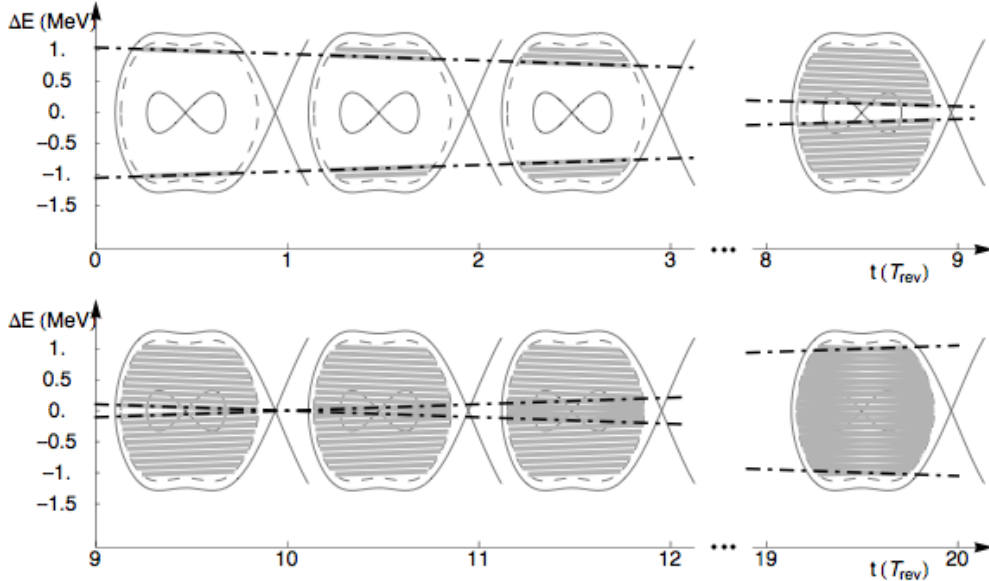

Figure 7: Principle of longitudinal injection painting with symmetric triangular energy modulation.

With a triangular shape of the amplitude modulation of this additional cavity, the painting scheme shown in Fig. 7 can be implemented. The scheme is very similar to the painting scheme with triangular energy modulation presented in the previous chapter. The bucket is painted symmetrically from high and low energies towards the center or inversely, instead of sweeping the mean energy through the whole bucket. Again, the injected beam is switched on and off, if the bunches end up inside or outside a contour corresponding to a given fraction of the bucket size. Note that for a strict implementation of the scheme as sketched in Fig. 7, with injection onto a ramp and, thus, an increase of the synchronous energy during the process, an additional mean to increase the mean Linac4 energy along the pulse would be needed.

4.2 Simulations with ESME and results obtained

In order to take direct space charge effects and, in particular, distortions of the bucket shape into account, simulations have been carried out with the code ESME [10]. Again, initial distributions have been generated by a Mathematica program and provided on files.

Only the case of the nominal LHC beam with single batch filling of the PS, i.e. $3.25 \cdot 10^{12}$ protons injected during 20 turns/ring and one energy modulation period, has been simulated. The bucket height and energy offsets computed neglecting direct space charge have been used. The energy modulation amplitude was 1.05 MeV. Again, the simulations have been carried out for a total of 10^6 macro-particles and a total duration of 3000 turns (~ 3 ms) and parameters to compute the direct space charge forces (number of bins in longitudinal positions to estimate the density and) have been adjusted carefully in order (i) to obtain sufficient resolution of the longitudinal density and direct space charge forces and, (ii) to be in-sensitive to numerical noise due to the limited number of macro-particles.

Plots summarizing the results of ESME simulations of injection painting with symmetric triangular energy modulation for nominal LHC operation are shown in Fig. 8. The results are similar to the corresponding ones with triangular energy modulation.

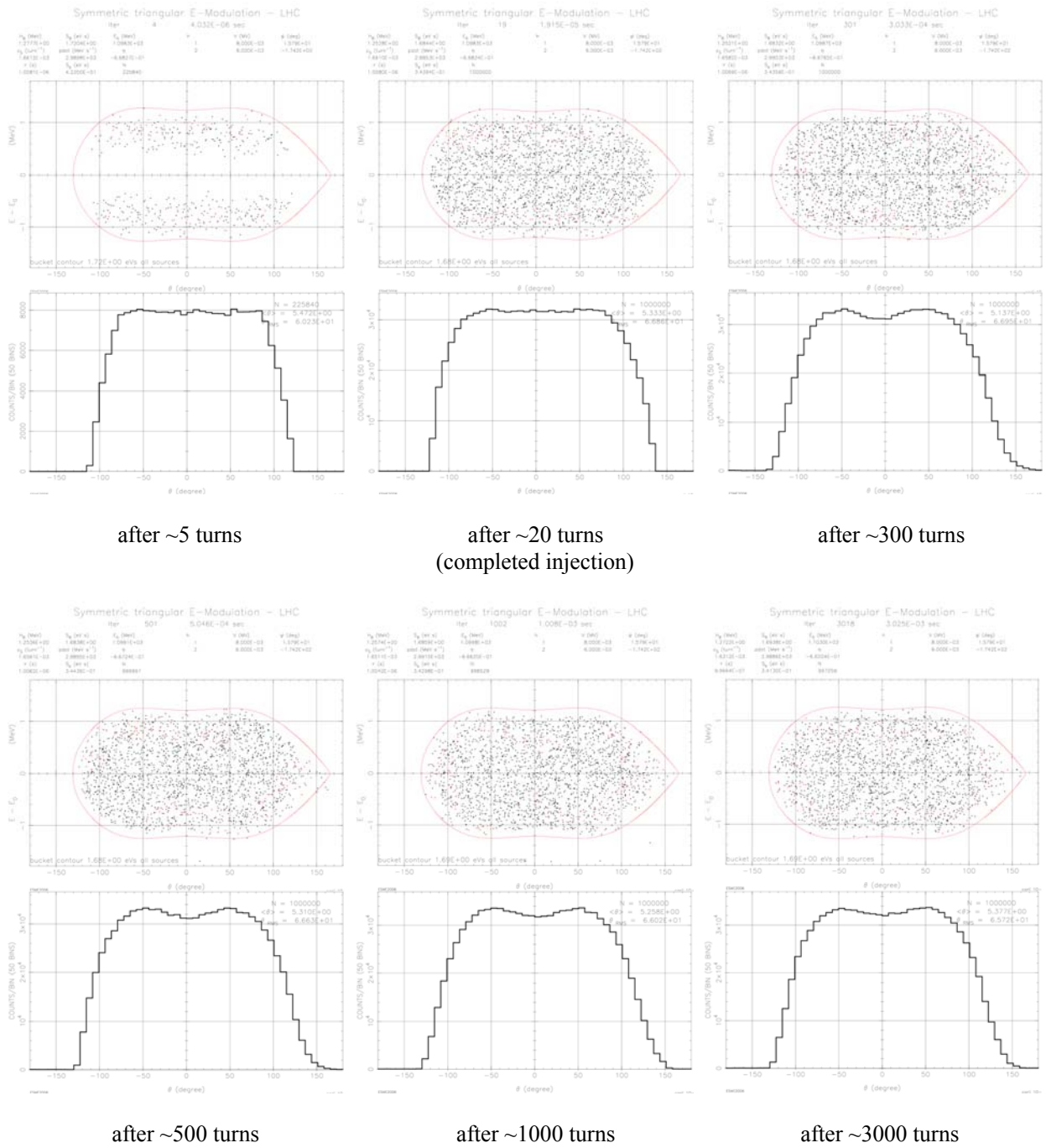

Figure 8: Simulation of injection painting with symmetric triangular energy modulation for a nominal LHC beam with single batch filling of the PS (i.e. $3.25 \cdot 10^{12}$ protons per ring).

5 Large energy spread without energy modulation

5.1 Motivation

For reference purposes in order to quantify the gain, which may be expected with longitudinal painting, a scheme making use of the chopper but without energy modulation, has been investigated. The aim has been to fill the waiting bucket with chopped beam with a large energy spread in order to “fit” the bucket as well as possible. A parabolic distribution has been assumed in energy. A parabolic distribution has been approached in bunch shape by superposing appropriate pieces of injected beam with the help of the chopper. Only the nominal LHC beam has been simulated with the same parameters to compute the direct space charge than used for the simulation of painting

5.2 Results

Plots summarizing the simulation results are shown in Fig. 6. One notes:

- A bit more than 98% of the injected particles remain until the end of the simulations. In fact, injection parameters (energy spread, length of beam slices injected) have been adjusted in order to allow for a fair comparison with the painting scheme proposed.
- Since the rectangular shaped regions in phase space occupied by the injected beam do not fit the bucket shape, significant in-homogeneities and, in turn, beating of the bunch shape occur. The bunch finally obtained has a dense core surrounded by regions with lower density.
- In general, the leading and trailing edge of the bunch shape are less steep and, in turn the bunching factors are reduced to typical values of ~ 0.53 (lowest value due to beating observed ~ 0.51).

6 Summary, Conclusions and Outlook

Longitudinal active painting schemes for the injection of the Linac4 beam into the PS Booster have been studied. The implementation of the first scheme with triangular shaped energy modulation is seriously considered in the frame of the Linac4 project. An alternative scheme with symmetric energy painting has been simulated as well, but requires an additional RF system at half the fundamental Linac4 frequency and, thus, will not be implemented.

For comparison, a scheme without energy modulation, but making use of the Linac4 chopper has been simulated as well. One concludes that a gain of a bit more than 10% in bunching factor and, in turn, in intensity for given transverse emittances, may be expected with the painting scheme.

In order to gain the same 10% in intensity (for given emittances) without painting, one would have to increase the injection energy by about 20 MeV to 180 MeV (Note: $(\beta\gamma^2)_{180\text{MeV}} \sim 1.1(\beta\gamma^2)_{160\text{MeV}}$). Thus, in order to judge whether it is worth to implement the scheme proposed, the efforts for the implementation of the scheme proposed should be compared to the investments needed to increase the Linac4 energy by ~ 20 MeV.

The next steps in view of an implementation of an active painting scheme for Linac4 are to investigate potential limitations and showstoppers and implications on the hardware needed:

- Investigations for a better understanding of the energy jitter to be expected and perturbations on the painting scheme: uncontrolled and excessive variations of the time evolution of the mean energy delivered by Linac4 may rule out any active painting scheme.
- Energy spread increase during the debunching of the residual Linac4 bunch structure during the first turns in the Booster. Note that protons injected at the beginning will experience the longitudinal fields created by Linac4 bunches injected later on until the end of the injection process.
- Studies on the feasibility and implementation of the energy modulation scheme have already started [11].
- Achieve consistent peak beam current between Linac4 design and assumptions for painting: In order to reduce the difficulties for the energy modulation hardware and to avoid that a large 6 dimensional volume is painted inefficiently within a few turns only, a minimum duration of the injection of about 20 turns has been assumed. The impact is that a peak current (during time intervals with the beam “switched on”) of about 41 mA is needed, i.e. a value significantly below the Linac4 design of 65 mA.
- Investigations on the impact of the painting scheme on transverse aspects of the PS Booster injection have already started [13]. In particular, the effect of different possible choices for the dispersion of the beam arriving on the stripping foil needs to be evaluated. The dispersion mismatch, if the beam arrives with zero dispersion, causes not only emittance growth, but introduces a correlation between transverse emittance and position in longitudinal phase space. If the beam arrives with a dispersion matched to the PS Booster lattice, the stripping foil must be wider and must stand more foil hits.

References

- [1] F. Gerigk and M. Vretenar (editors), *Linac4 Technical Design Report*, CERN-AB-2006-084 ABP/RF.
- [2] J.P. Delahaye, G. Gelato, L. Magnani, G. Nassibian, F. Pedersen, K.H. Reich, K. Schindl, H. Schönauer, *Shaping of Proton Distribution for Raising the Space-charge of the PS Booster*, Proceedings of the 11th International Conference on High Energy Accelerators, Geneva (1980).
- [3] G. Gelato, L. Magnani, N. Rasmussen, K. Schindl, H. Schönauer, *Progress in Space-charge limited Machines: four times the Design Intensity in the CERN Proton Synchrotron Booster*, Proceedings of the Particle Accelerator Conference PAC1987.
- [4] K. Hanke, J. Sanchez-Conejo and R. Scrivens, *Dispersion Matching of a Space Charge dominated Beam at Injection into the CERN PS Booster*, Proceedings of the Particle Accelerator Conference PAC 2005 and CERN-AB-2005-032.
- [5] M. Chanel and F. Pedersen, *private communications*.
- [6] P. Gruber (editor) et al., *The Study of a European Neutrino Factory Complex*, Chapter 2 (Section 3.2) of CERN 2004-002.
- [7] M. Yamamoto, F. Tamura, E. Ezura, Y. Hashimoto, Y. Mori, C. Ohmori, A. Schnase, A. Takagi, T. Uesugi, M. Yoshii, *Longitudinal Beam Dynamics on 3 GeV PS in JEARI-KEK joint Project*, Proceedings of European Accelerator Physics Conference EPAC 2002.
- [8] K.H. Reich and K. Schindl, *Proton Synchrotron Booster (PSB) Parameter List*, PS/BR Note 82-11
- [9] Particle Properties Booklet edition 2004.
- [10] J. MacLachlan and F. Ostiguy, *ESME program*, <http://www-ap.fnal.gov/ESME/> or J. MacLachlan, *Particle Tracking in E-Phi Space for Synchrotron Design & Diagnosis*, Proceedings of the 12th Conf. on Applications of Accelerators in Research and Industry and Fermilab-CONF-92/333 (Nov. 92).
- [11] F. Gerigk and M. Vretenar, *private communications*.
- [12] B. Goddard, *private communications (on simulations of the PS Booster H injection without direct space charge forces to evaluate consequences for the stripping foil)*.
- [13] M. Aiba and B. Goddard, *private communications (on first modeling of the PS Booster H injection and first results with the code ORBIT taking direct space charge forces into account)*.