

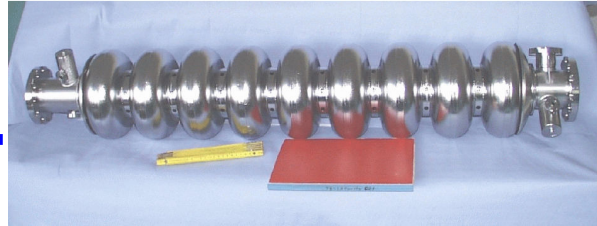

SRF



Research and Development on Superconducting Radio-Frequency Technology for Electron Linear Accelerators

Deliverable 9.4.2.5

RF GUN CONTROL

Elmar Vogel, Waldemar Koprek, Piotr Pucyk, Stefan Simrock
DESY Hamburg

Abstract

At the DESY Vacuum Ultraviolet Free Electron Laser (VUV-FEL) bunch peak current and the SASE effect are (amongst other parameters) sensitive to beam energy and beam phase variations. The electron bunches are created in a RF gun, which does not have field probes. Variation of the gun RF field causes variation of beam energy and phase. They have a significant influence on the overall performance of the facility.

DSP based rf field control used previously was only able to stabilize the rf output of the klystron. This was due to the lack of processing power and the over-all loop delay. The controller was not able to provide satisfactory rf field stability in the gun.

Replacing the DSP hardware by the new FPGA-based hardware Simulation Controller (SimCon), we are able to reduce the latency within the digital part significantly allowing for higher loop gain. Furthermore SimCon provides sufficient processing power for calculating a probe signal from the forward and reflected power as input for PI and adaptive feed forward (AFF) control.

I Introduction

The bunch compression in the injector and the SASE effect are sensitive to beam energy variations. Bunch compression requires bunches accelerated off the rf field crest to obtain an energy chirp from the bunch head to the tail. Variations of the phasing between the rf gun laser created electron bunches, the rf field within the gun and the rf field of the (off crest) accelerating modules before the bunch compressors change the beam energy and affect the performance of the VUV-FEL. Practice has shown that the phase of the gun rf has to be stabilized better than 0.5° .

The resonant frequency of the VUV-FEL rf gun can only be tuned by changing the gun temperature via the cooling water flow [1]. In steady state operation the temperature is stabilized to a level of 0.1° corresponding to 2.3 kHz and an rf phase of 2° . Hence, the rf control has to further stabilize the rf field. Operating the rf gun with high rf voltages of 40 MV/m reduces emittance dilution due to the space charge effect. Following a rigorous cylinder symmetric design, the gun provides no rf probe. As a consequence the rf field has to be calculated from the forward and reflected power supplying a sensor signal to an rf field controller.

II Description of Work

From the set point table, a 1.3 GHz drive signal is generated via a digital to analog converter (DAC) steering a vector modulator. This signal is amplified by a preamplifier and a klystron generating up to 3 MW of rf power driving the gun via an axial symmetric input coupler. The rf field inside the cavity is determined by the forward and reflected power measured at a directional coupler. Both directional coupler signals are down converted to the base band and sampled by ADCs. After signal calibration, the controller calculates the vector sum providing a ‘virtual rf probe’ signal for the subsequent control algorithms. Subtracting the ‘probe’ signal from the set point gives the error signal.

Amplifying slow varying error signals by the gain factor g and adding the result to the drive signal reduces the field error by the gain factor. For error signals changing faster than the time required for the signal to propagate through this (fast) proportional control loop, we get positive feedback and the loop becomes unstable for higher gain factors. Fast changing error signals are suppressed by the 60 kHz bandwidth of the gun copper cavity. Together with the loop delay of $1.3 \mu\text{s}$, this results in a maximum stable gain of about 3. To further increase the gain at low frequencies, an infinite impulse response (IIR) low-pass filter is added. Stable gain values up to 6 are achieved with an IIR frequency of 20 kHz. An IIR filter is used rather than a finite impulse response (FIR) filter because the use of an FIR filter would significantly increase the loop delay.

III Discussion of Work

In April 2006 the last version of the RF-Gun controller was implemented in a SIMCON 3.1 board and installed in DESY-Zeuthen. New iq-detectors were used for field detection. It was the first time that information about the field inside a cavity was used for a control loop in a SIMCON controller. This solution improved the field stability in the cavity.

In order to reduce EMI on the link between the iq-detector and the ADC, they should be laced as close as possible and are therefore placed on one PCB.

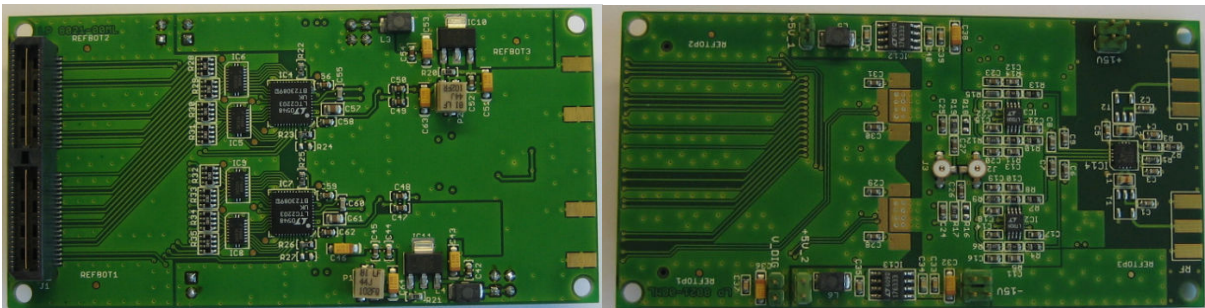

Fig. 1: Top and bottom view of the iq-detector

The iq-detector (LT5516), the differential buffer amplifier (LT1994) and the 16-bit ADC (LT2203) are delivered from Linear Technologies and designed for the telecommunication industry. The new detector (iq-detector and ADC) promises to provide a better noise and EMI performance than the currently installed iq-detector (AD8347) and 8-channel ADC board (based on 14-bit AD9240).

For the readout of the ADC data, a motherboard with FPGA, memory, and components as well as connectors for communication was designed and assembled.

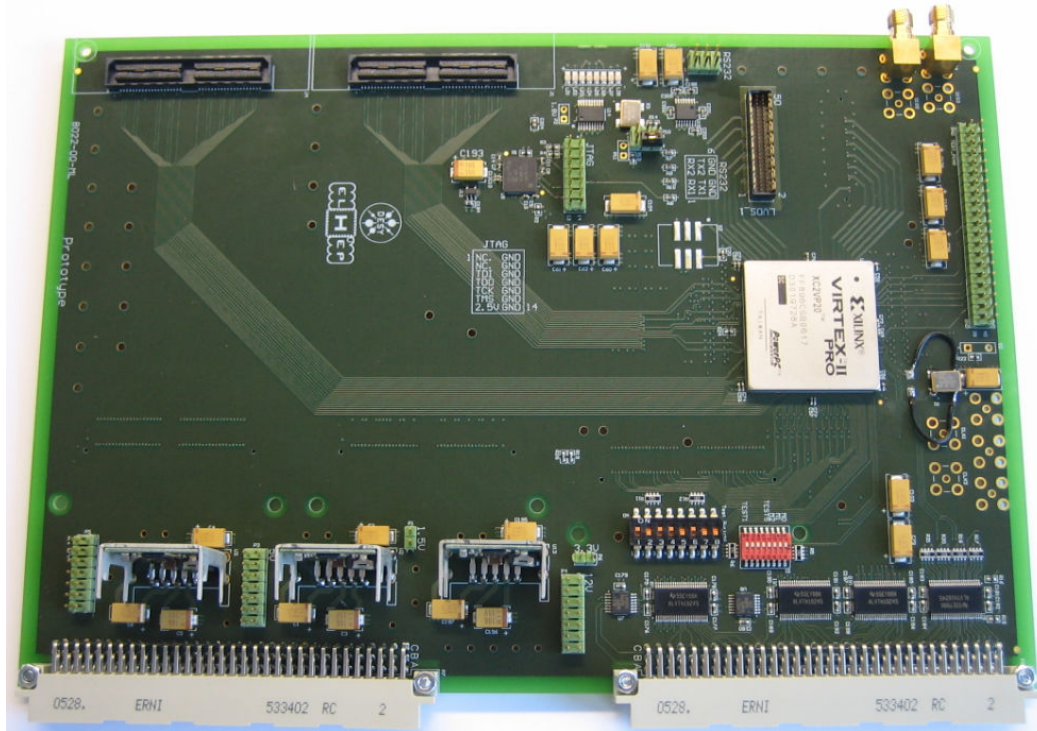

Fig. 2: Top view of the motherboard (bottom layer has 3 additional connectors)

Features:

- Xilinx Virtex II Pro – FPGA chip which is used to collect data from ADCs on analogue boards. This FPGA is also used for computation.
- VME is used as interface to control software,
- RS-232 is an optional control interface,
- LVDS connectors are used to send data from ADCs to another similar board,
- 5 QSE high speed data connector as an interface to analogue daughter boards.

For connection between detector and motherboard, an 80-pin QSE high-speed data connector from SAMTEC Inc. was chosen.

It is planned to test this new system in the accelerator in parallel with the current scheme, to compare the results.

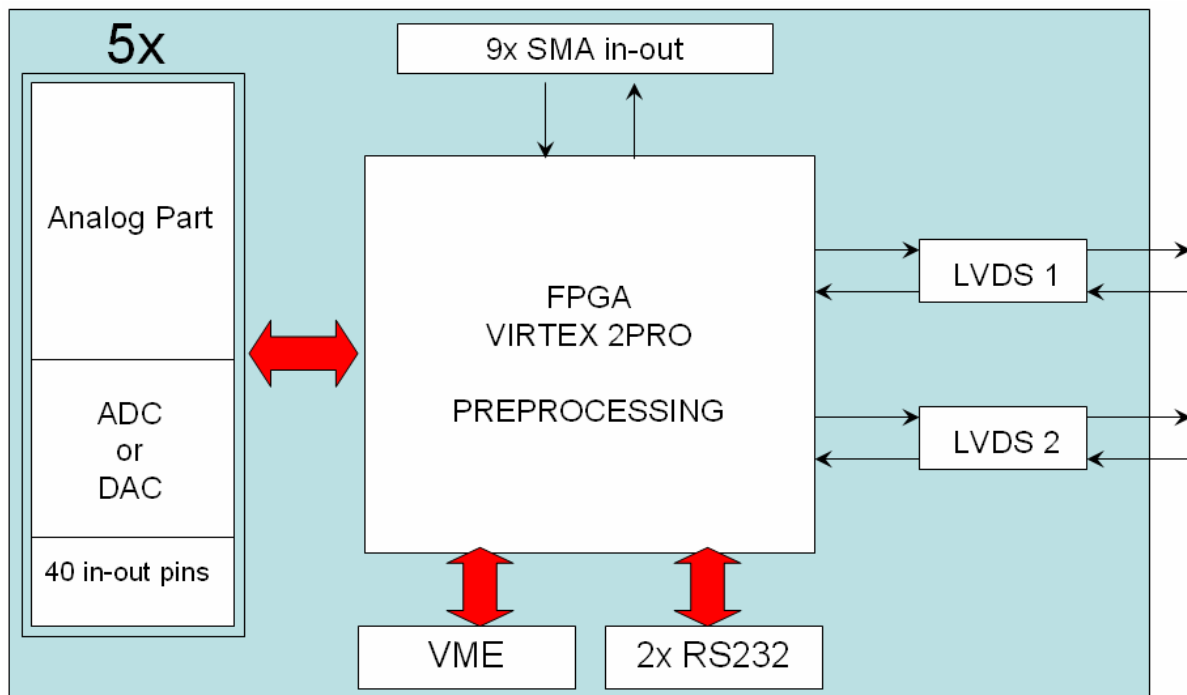

Fig.3: Block diagram of the motherboard

In normal operation, the phasing between the laser pulse generating electrons by the photo effect and the rf field (emission phase) is adjusted to accelerate electrons away from the cathode. With opposite phasing no beam is generated. Between both cases the number of electrons leaving the gun is an almost linear function of the phasing. We use this interrelation for beam based qualification of the emission phase (and rf phase) stability. The accuracy of this method is about 0.1° .

When the controller drives the klystron and rf gun without any feedback, a systematic phase change within the rf pulse of $2.2^\circ/400 \mu s$ is visible. This is mainly caused by the cavity heating due to rf power dissipation resulting in a systematic de-tuning of the rf pulse. However, this phase change is reduced to $0.7^\circ/400 \mu s$ operating with PI control and to $0.3^\circ/400 \mu s$ operating with alternating AFF and PI control (1:9). Parallel operation of AFF and P control leads to similar results. AFF and PI control together behaves unstably.

The statistical (rms.) values reflect the same behavior: without control, the changes from bunch to bunch and from rf pulse to pulse are larger than 0.5° . PI control reduces these to less than 0.2° . Alternating AFF and PI control and AFF together with P control leads to the most promising results.

IV Conclusions

With the FPGA based rf control and the algorithms, the field of the rf gun at FLASH is well stabilized for SASE operation. For rf pulse lengths of the order of $100 \mu s$ PI control alone is sufficient. Longer rf pulses and bunch trains require AFF control in addition.

The future European XFEL requires more stable rf gun emission phases. Therefore, the resolution of the beam based measurement will be improved and potential jitter in the laser timing will be examined and eventually be cured. In parallel, new down converters are under development to reduce noise for the controller input.

V Acknowledgements

We acknowledge the support of the European Community-Research Infrastructure Activity under the FP6 "Structuring the European Research Area" programme (CARE, contract number RII3-CT-2003-506395)

VI Appendix

FPGA BASED RF FIELD CONTROL AT THE PHOTO CATHODE RF GUN OF THE DESY VACUUM ULTRAVIOLET FREE ELECTRON LASER

Elmar Vogel, Waldemar Koprek, Piotr Pucyk, DESY, Hamburg, Germany

Abstract

At the DESY Vacuum Ultraviolet Free Electron Laser (VUV-FEL) bunch peak current and the SASE effect are (amongst other parameters) sensitive to beam energy and beam phase variations. The electron bunches are created in an rf gun, which does not have field probes. Variations of the gun rf field cause beam energy and phase variations. They have a significant influence on the overall performance of the facility.

DSP based rf field control used previously was only able to stabilize the rf output of the klystron. This was due to the lack of processing power and the over-all loop delay. The controller was not able to provide satisfactory rf field stability in the gun.

Replacing the DSP hardware by the new FPGA-based hardware Simulation Controller (SimCon), we are able to reduce the latency within the digital part significantly allowing for higher loop gain. Furthermore SimCon provides sufficient processing power for calculating a probe signal from the forward and reflected power as input for PI and adaptive feed forward (AFF) control.

In this paper we describe the algorithms implemented and the gun rf field stability obtained.

INTRODUCTION

The DESY Vacuum Ultraviolet Free Electron Laser (VUV-FEL) accelerates electron bunches to energies from 0.3 to 1 GeV every 200 ms in batches occupying 800 μ s at most with bunch spacings of 1 μ s or multiple. While passing an undulator the bunches emit high brilliant coherent light in the vacuum ultraviolet range from 100 to 3 nm. This process is called Self-Amplified Spontaneous Emission (SASE). Major prerequisites are high electron peak currents of 1 to 2 kA and transverse emittances in the range of 1 to 2 μ m. Starting from 1 nC electron bunches ($0.62 \cdot 10^{10}$ particles), the high peak currents are obtained by compressing the bunch length down to the 100 fs range. The compression is done within transverse chicanes, called bunch compressors.

The bunch compression in the injector and the SASE effect are sensitive to beam energy variations. Bunch compression requires bunches accelerated off the rf field crest to obtain an energy chirp from the bunch head to the tail. Variations of the phasing between the rf gun laser creating the electron bunches, the rf field within the gun and the rf field of the (off crest) accelerating modules before the bunch compressors change the beam energy and affect the performance of the VUV-FEL. Practice has shown that the phase of the gun rf has to be stabilized better than 0.5° .

The resonant frequency of the VUV-FEL rf gun can only be tuned by changing the gun temperature via the

cooling water flow [1]. In steady state operation the temperature is stabilized to a level of 0.1° corresponding to 2.3 kHz and an rf phase of 2° . Hence, the rf control has to further stabilize the rf field. Operating the rf gun with high rf voltages of 40MV/m reduces emittance dilution due to the space charge effect. Following a rigorous cylinder symmetric design, the gun provides no rf probe. As a consequence the rf field has to be calculated from the forward and reflected power supplying a sensor signal to an rf field controller.

The DSP based rf field control used previously was only able to stabilize the rf drive from the klystron due to the lack of processing power and an over-all loop delay of 3 μ s. In all, it was not able to provide the rf field stability required. The contribution to the loop delay of the DSP hardware and the algorithms was about 2.3 μ s. Replacing the DSP hardware by the new XILINX Virtex-II Pro (XC2VP 30) FPGA-based hardware SimCon 3.1 [2], we are able to reduce the contribution of the digital part down to 0.5 μ s resulting in a delay of 1.3 μ s. Furthermore SimCon provides sufficient processing power to calculate a probe signal from the forward and reflected power as input for a proportional (P) controller. At a nominal rf pulse length of 800 μ s, the gun temperature changes within the pulse resulting in a resonant frequency change of about 8 kHz [3]. Using adaptive feed forward (AFF) keeps the cavity rf field constant.

CONTROL ALGORITHMS

Figure 1 shows a block diagram of the control algorithms applied to the DESY VUV-FEL rf gun:

From the set point table, a 1.3 GHz drive signal is generated via a digital to analog converter (DAC) steering a vector modulator. This signal is amplified by a preamplifier and a klystron generating up to 3 MW of rf power driving the gun via an axial symmetric input coupler. The rf field inside the cavity is determined by the forward and reflected power measured at a directional coupler. Both directional coupler signals are down converted to the baseband and sampled by ADCs. After signal calibration, the controller calculates the vector sum providing a 'virtual rf probe' signal for the subsequent control algorithms. Subtracting the 'probe' signal from the set point gives the error signal.

Amplifying slow varying error signals by the gain factor g and adding the result to the drive signal reduces the field error by $1/(1+g)$. For error signals changing faster than the time required for the signal to propagate through this (fast) proportional control loop (1), we get positive feedback and the loop becomes unstable for higher gain factors. Fast changing error signals are suppressed by the 60 kHz bandwidth of the gun copper cavity. Together with the loop delay of 1.3 μ s, this results in a maximum

stable gain² of about 3. To further increase the gain at low frequencies, an infinite impulse response (IIR) low-pass filter (Fig. 2) is added. Stable gain values up to 6 are achieved with an IIR frequency of 20 kHz. An IIR filter is used rather than an finite impulse response (FIR) filter because the use of an FIR filter would significantly increase the loop delay (by 16 μ s).

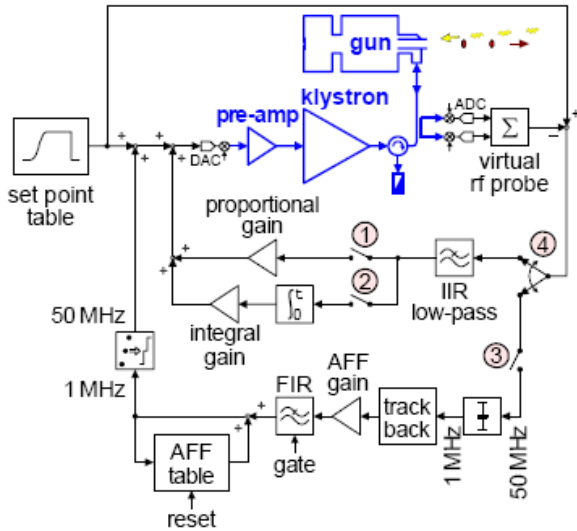

Figure 1: Block diagram of the gun rf control implemented in SimCon (black) surrounding the high power rf (blue). DACs in front of the vector modulator (\otimes) and ADCs after down converters (\otimes) are part of SimCon.

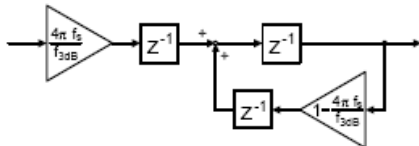

Figure 2: Recursive low-pass with infinite impulse response. The filter gain values depend on the processing frequency $f_s = 50$ MHz and the filter frequency f_{3dB} .

Summing error signals, amplifying them and adding the result to the drive signal implements an integral control loop (2). At the rf gun, rf field deviations slowly building up are more adequately treated with an adaptive feed forward (AFF), as they are mainly repetitive from rf pulse to rf pulse.

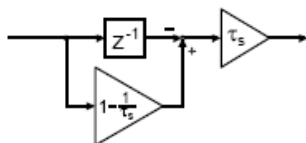

Figure 3: Determination of the set point error leading to the errors measured (track back)

Based on a model for the high power rf, an AFF calculates from the error signal a drive signal correction which minimizes the control error for subsequent rf pulses [4]. We simplify the high power rf to an ordinary first order low pass describing the bandwidth limitation $\delta f = 60$ kHz of the gun cavity.

Figure 3 shows the tracking of the reduction $1/t_s = 2\pi \delta f T_s$ from an rf field error sample by rf power dissipation within one sample step T_s . The difference of the tracked sample and the subsequent error sample is caused by an imperfect drive signal for the time of the subsequent sample. Hence, correcting the drive signal for the next rf pulses by this difference minimizes repetitive control errors.

Sample difference values are sensitive to measurement noise. Therefore, an FIR filter is used to smooth the values without influencing the over-all time structure due to its constant group delay. After filtering the correction values are added to those calculated previously ('AFF table' in Fig. 1). Finally, the drive signal is corrected by the values accumulated.

The algorithm becomes less sensitive to non repetitive errors by choosing AFF gains (Fig. 1) less than 1, but then it adapts more slowly.

Reducing the sampling rate from 50 MHz to 1 MHz for the AFF by averaging, reduces the number of the FIR filter coefficients required (to 32 for a 20 kHz low-pass) and the AFF table size. At the end of the rf pulse the set point drops to zero.

This enables cavity de-tuning and time constant determination by measuring the free rf field decay. By so doing the controller detects a big control error after the set point is switched to zero. Gating this error signal out is a sufficient cure for the PI (fast) controller. However, the FIR filter within the AFF responds to this step with overshoots building up unwanted correction values at the AFF-table end. This problem can be resolved using the gating scheme shown in Fig. 4.

At the end of the rf pulse the gate input is switched from one to zero. All subsequent input values are suppressed by multiplication with zero. As a result the FIR summands vanish step by step and the sum and FIR output becomes smaller. This reduction can be compensated by normalizing the FIR output to the number of nonzero summands counted by a shift register.

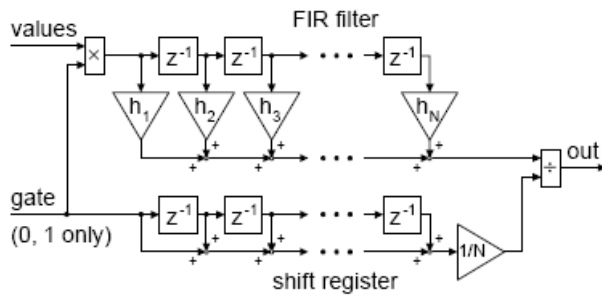

Figure 4: A gated FIR filter avoids overshoots at the rf pulse end, when the error signal is gated out and therefore vanishes suddenly

The AFF algorithm described is compact enough to be implemented within the Virtex-II Pro FPGA of SimCon. Errors are not perfectly compensated by applying the algorithm only once due to the simple high power rf model used. But, this fact is well compensated by the iterative application from rf pulse to rf pulse.

The controller can operate with AFF alone for one rf pulse followed by fast control alone for several (9) rf pulses but with AFF-table applied. This operation is indicated by the double arrow at switch (4) in Fig. 1. Results presented in the study here, refer to this operation. Both loops can also work parallel and (4) supplies error signals accordingly.

RF FIELD STABILITY ACHIEVED

In normal operation, the phasing between the laser pulse generating electrons by the photo effect and the rf field (emission phase) is adjusted to accelerate electrons away from the cathode. With opposite phasing no beam is generated. Between both cases the number of electrons leaving the gun is an almost linear function of the phasing [5]. We use this interrelation for beam based qualification of the emission phase (and rf phase) stability [6]. The accuracy of this method is about 0.1° .

Table 1 shows the emission phase stability of the DESY VUV-FEL rf gun measured. We took the data by operating rf pulse lengths of $500 \mu\text{s}$ and creating 25 bunches with $20 \mu\text{s}$ bunch spacing. Values for the phase change over time omit the five leading bunches to suppress some excursions. The r.m.s values given are based on all 25 bunches measured over 12 minutes. This period of time covers rf gun temperature control oscillations.

When the controller drives the klystron and rf gun without any feedback, a systematic phase change within the rf pulse of $2.2^\circ/400 \mu\text{s}$ is visible. This is mainly caused by the cavity heating from rf power dissipation resulting in a systematic de-tuning over the rf pulse. However, this phase change is reduced to $0.7^\circ/400 \mu\text{s}$ operating with PI control and to $0.3^\circ/400 \mu\text{s}$ operating with alternating AFF and PI control (1:9). Parallel operation of AFF and P control leads to similar results. AFF and PI control together behaves unstably.

The statistical (r.m.s.) values reflect the same behaviour: without control, the changes from bunch to bunch and from rf pulse to pulse are larger than 0.5° . PI

control reduces these to less than 0.2° . Alternating AFF and PI control and AFF together with P control leads to the most promising results.

Table 1: Emission phase stability measured

rf control	phase change over time	phase r.m.s. bunch to bunch	phase r.m.s. pulse to pulse
rf drive only	$2.2^\circ/400 \mu\text{s}$	0.73°	0.50°
PI control	$0.7^\circ/400 \mu\text{s}$	0.18°	0.17°
AFF(1) PI(9)	$0.3^\circ/400 \mu\text{s}$	0.10°	0.13°
AFF and P	as above	as above	as above
AFF and PI	unstable	unstable	unstable

CONCLUSION AND OUTLOOK

With the FPGA based rf control and the algorithms presented, the DESY VUV-FEL gun rf field is well stabilized for SASE operation. For rf pulse lengths of the order of $100 \mu\text{s}$ PI control alone is sufficient. Longer rf pulses and bunch trains require AFF control in addition.

The future European XFEL requires more stable rf gun emission phases. Therefore, the resolution of the beambased measurement will be improved and potential jitter in the laser timing examined and eventually treated. In parallel, new down converters are in development to reduce noise for the controller input.

ACKNOWLEDGEMENTS

We would like to thank Matthias Hoffmann for assistance with controller input signal calibration. For provision of the beam based phase measurement we are grateful to Holger Schlarb. We also offer our thanks to Stefan Simrock and John Maidment for proof-reading, discussions and suggestions.

REFERENCES

- [1] J. Baehr, I. Bohnet, J.-P. Carneiro, K. Floettmann, J. H. Han, M. v. Hartrott, M. Krasilnikov, O. Krebs, D. Lipka, F. Marhauser, V. Miltchev, A. Oppelt, B. Petrossyan, S. Schreiber, F. Stephan, TESLA Note 2003-33, 2003
- [2] W. Giergusiewicz, W. Jalmuzna, K. Pozniak, N. Ignashin, M. Grecki D.V.M., D. Makowski, T. Jezynski, K. Perkuszewski, K. Czuba, S. Simrock, R. Romaniuk, *Proc. of SPIE Vol. 5948*, 2005
- [3] D. Kotthaus, Diplomarbeit, University of Hamburg (2004)
- [4] M. Liepe, S. Simrock, *Proc. of EPAC98*, 1998
- [5] J.-H. Han, DESY-THESIS-2005-045, 2005
- [6] H. Schlarb, N. Heidbrook, H. Kapitza, F. Ludwig, N. Nagad, *Proc. of EPAC06*, 2006

¹bunch spacings of $0.11 \mu\text{s}$ (9MHz) are in preparation.

²phase reserve $\varnothing_R = 30^\circ$ and amplitude reserve $A_R = 1.8$

