

EU contract number RII3-CT-2003-506395

CARE-Report-2007-035-HIPPI



1MW - 704 MHz RF test stand at CEA-Saclay

S. Chel, M. Desmons, A. Hamdi, J.-F. Denis,
F. Ballester, D. Roudier, G. Monnereau, G. Bourdelle

CEA/Saclay F-91191 Gif-sur-Yvette

Abstract

In the frame of the CARE/HIPPI programme, superconducting accelerating cavities for pulsed proton injectors are developed. Qualification of these 704 MHz RF structures fully equipped (housed in a helium tank, with tuning system and power coupler), requires to perform high power tests in the existing horizontal cryostat CryHoLab. Before the CARE programme started, not any of European test sites was equipped with a 704 MHz high power RF source in the MW range. During the last two years, CEA-Saclay built and ordered the necessary RF equipments to make such a platform for high power RF tests in a cryogenic environment available to the partners in HIPPI and later on to any other interested European teams.

Introduction

In the frame of the CARE/HIPPI programme, CEA-Saclay built and ordered the necessary RF equipments to make a platform for high power tests in a cryogenic environment available. Only few similar platforms are existing in Europe (at CERN for tests at 352 and 400 MHz, at DESY and BESSY for tests at 1300 MHz) but not any was equipped to perform RF power tests at 704 MHz. This RF frequency was chosen in the reference design of the CERN-SPL-II [1] for the medium and high energy parts of the superconducting linac. With such an equipment, qualification of the different components (superconducting cavities of various beta's, high power couplers, tuning systems and compensation scheme, ...) of superconducting linacs for accelerating high intensity pulsed proton beams are now possible.

This paper describes the RF test stand main components: the 275 KVA DC High Voltage Power Supply, the 50Hz High Voltage pulsed modulator and the 1MW, 704.4MHz RF klystron amplifier. All these components with other RF already existing components (1300 MHz klystron, 700 MHz IOT) were installed on a large platform (see Fig. 1). The RF source outputs are connected to coupler test stand and/or the horizontal cryostat CryHolab through a network of waveguides (WR 1500 & 1150 for the 704 MHz RF power, and WR650 for the 1300 MHz RF power).

The results of the first HV and RF measurements performed in the 3rd quarter of 2007 are presented. At the end of these tests, the 704 MHz RF test stand is qualified in terms of peak power and pulse length.

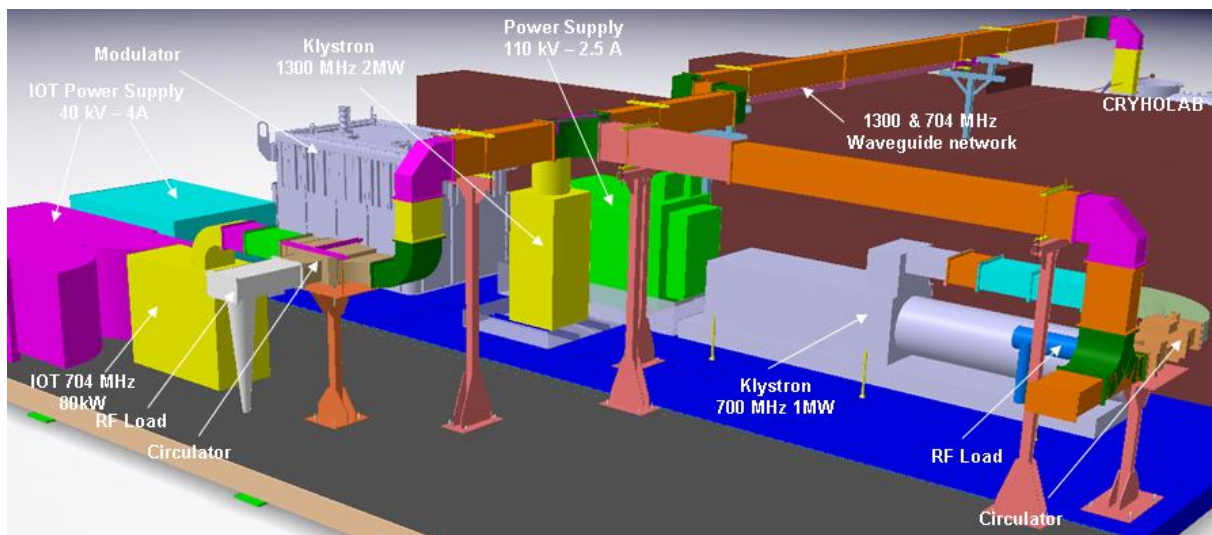

Fig. 1 : General layout of the RF platform at CEA-Saclay

Main components

1) HV Power Supply

The High Voltage continuous power supply HVPS figure (AL3-110-2500-R-Pi-F) consists of a differential 110KV-2.5A output, and its main characteristics are:

- Output DC power from 0 to 275kW
- Overload and breakdown protection
- Oil tank cooling with airflow
- Monitoring of output voltage and current (UART, 0-10V)
- Monitoring of gas pressure and temperature

The 300KVA input power is supplied through three phases to three thyristors (Semikron SKKT 500/14E) controlling the voltage applied to a 3-phases transformer of triangle-star type. The high voltage is rectified with six high voltage diodes (Semikron SKNa 20/17) to output the continuous power.

During the first high voltage tests, a breakdown occurred causing a failure on the HVPS. After investigations, we found out that a HV rectifier diode was destroyed limiting the HV output to 30 kV. Moreover, black substances were seen in the oil tank which could have moved near the HV diode and generated a short circuit. Due to this incident, the HVPS was shipped back to the factory. The HV diode was replaced, the whole HV components were cleaned and the oil was filtered and heated before refilling in the tank. Three months after leaving Saclay, the HVPS has been reconnected and is now ready to operate.

2) HV Modulator

The HV modulator is of hard-tube pulse generator type. Designed by CEA/DAPNIA in collaboration with IN2P3/LAL and fabricated by IN2P3-LAL (Fig. 2), it has been used 10 years ago to drive a Thomson klystron TH2086 (peak RF power: 2MW, pulse length: 1ms, repetition rate: 10Hz) for a R&D program on 1300 MHz high power couplers.

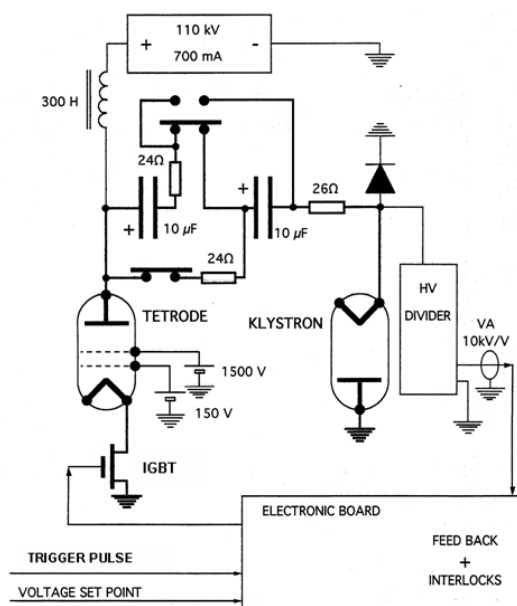

Fig. 2 : First electronic design of the HV modulator

In order to match the new requirements of the 704 MHz klystron, a major upgrade has been undertaken. Indeed, the frequency repetition and the pulse length were not compatible with the old design and electronic components anymore. The required characteristics are:

- Output HV pulse width: 2.2 ms
- Frequency repetition adjustable from 1 to 50Hz
- Output peak voltage: 96kV
- Max. peak-to-peak ripple @ 95kV: 200 V
- Fast rise and fall times (100 μ s settling time@0.5%)
- Limitation of the energy dissipation in case of arc or breakdown (50 Ω resistor limits the arc energy to 50J and makes the discharge to be damped)
- Oil cooling to dissipate the average power of 8 kW at max. duty cycle

The new electronic scheme of a modulator matching these requirements is shown in Fig. 3. The main modifications consisted of the addition of one HV feedthrough to connect the floating HVPS, of higher power rated limitation resistors in order to protect both the tetrode and the klystron in case of simultaneous breakdown and of oil cooling channels. And since the HVPS runs in floating mode, the 300 H choke inductance was removed.

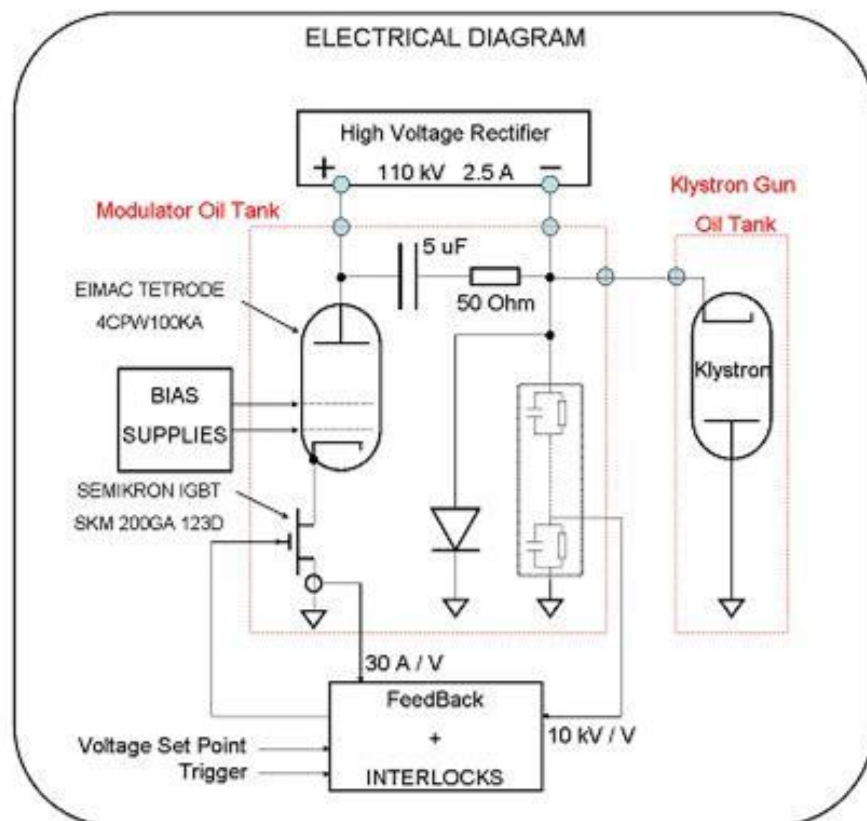

Fig. 3: Electrical diagram of Pulsed High Voltage Modulator

The protection diode connected to the negative pole avoids voltage inversion on klystron and allows the connection of a single ended high voltage positive power supply, thus enabling high voltage tests at limited repetition rate.

After the upgrade of the electronic design and components, some other improvements have been added (Fig. 4): new mechanical frame to remove easily the electronics out of the oil tank, new connections to the differential HVPS, new cooling system to sustain the full duty cycle.

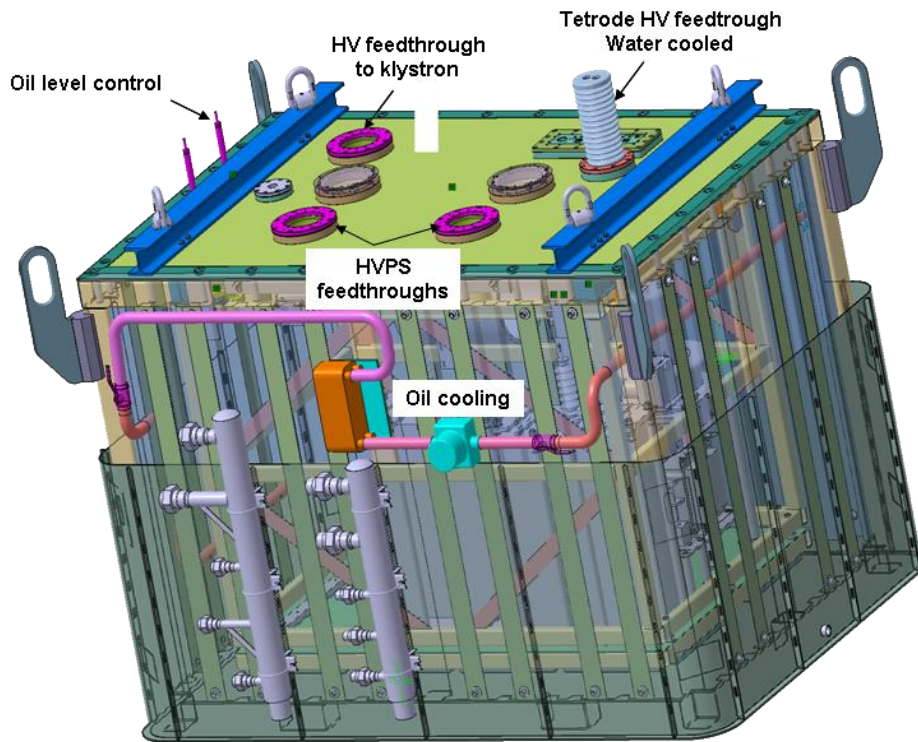

Figure 4: 3D-view of the upgraded modulator

Moreover, in order to safely increase the duty cycle up to 10%, great care must be taken to avoid an excess of dissipating power in the tetrode and the IGBT: The tetrode screen grid voltage has to be carefully optimized. After preliminary measurements (Fig. 5), the klystron current and voltage values required for generation of a given RF power pulse at the klystron output have been reached with appropriate settings of the tetrode screen grid voltage shown in figure 5.

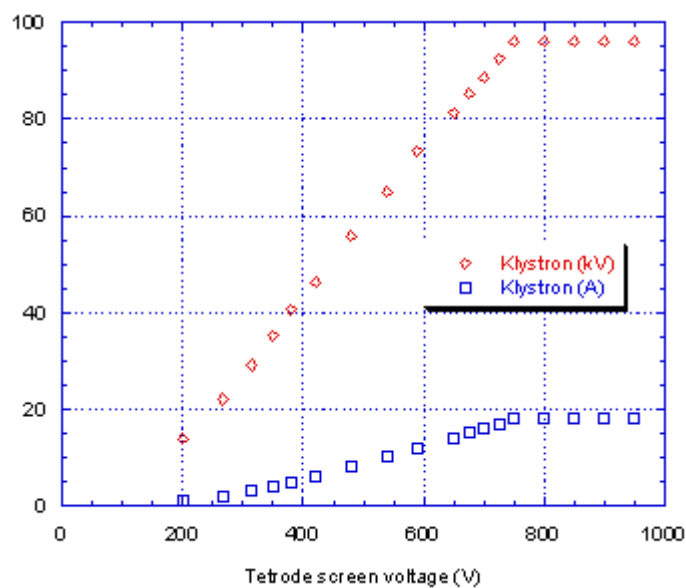

Figure 5: Current and Voltage modulator output vs. tetrode screen grid voltage with $V(\text{anode_tetrode})=5\text{kV}$ and $V(\text{drain_IGBT})=25\text{V}$

3) Klystron

The 704MHz VPK 7952C Klystron (Fig. 6) is a high power tube developed by CPI for scientific applications. The modulator drives the klystron in a pulse cathode modulation mode. Main specifications of the klystron are :

Center Frequency [MHz]	704
Frequency band @ -1dB [MHz]	+/- 1
Peak Output power [kW]	1000
Average Output power [kW]	100
RF Drive power [W]	10
Gain [dB]	50
Max. Cathode Voltage [kVdc]	95
Max. Beam current [A dc]	17
RF Leakage [mW/cm ²]	0.2
X rad. @ 1m (public exp.) [mS/hr]	0.5

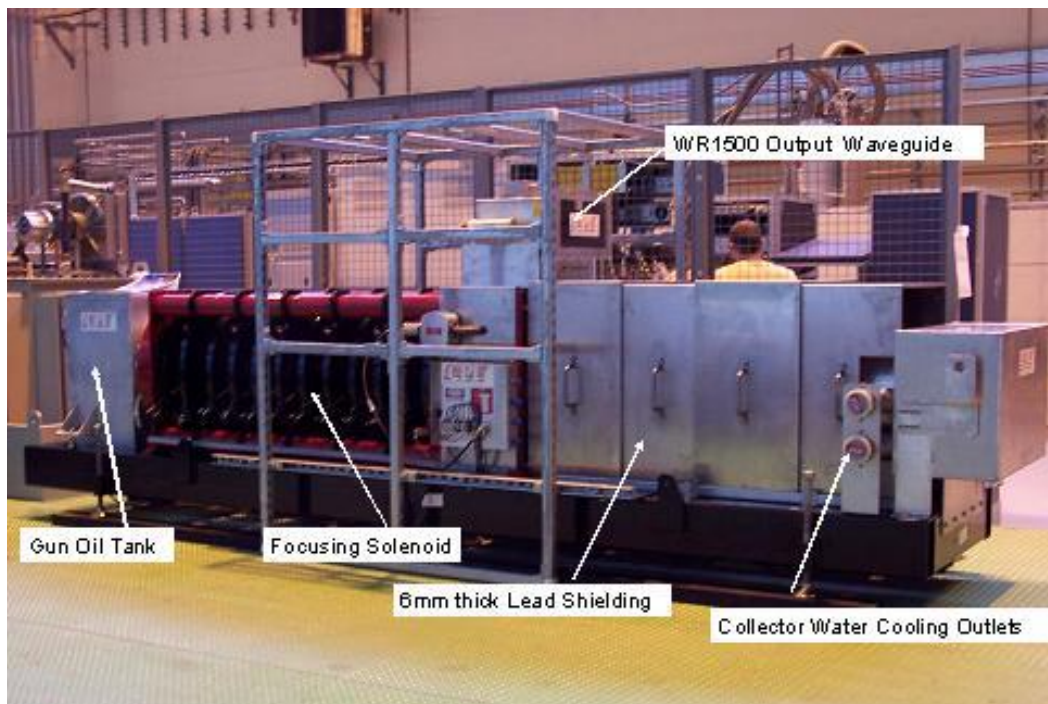

Fig. 6: Klystron VPK 7952C amplifier (CPI), with Pb-shield mounted on the collector section

This klystron requires four auxiliaries power supply (Fig. 7), two for the focusing coils, one for the vacuum pump and one for the primary filament. Both of the 8 l/sec Vacion pump power supplies are controlled serially (RS232). The pressure value is monitored and is used as a double level interlock ($10\mu\text{A}$ = HV pulses switch off and $100\mu\text{A}$ = filament power supply switch off). The primary filament power supply is also controlled via RS232 and the voltage ramp up to the nominal heater power is done by software. Current measurement of the klystron magnet is done through a home-made rack which insures the fast measurement of analogue voltage and current

of the coils at the PXI. This rack also includes a capacitive compensation of the magnet inductance to avoid power supply instability.

In order to achieve the nominal RF performances, different cooling circuits are needed. In one hand, for the collector and body cooling circuits, the water temperature is kept in a $\pm 0.5^\circ$ range ; this is controlled with temperature and pressure sensors located at the cooling circuit outlets. Moreover, the resistivity of deionised water is measured to prevent any variation. In the other hand, for the RF window of the klystron output, a air-flow cooling system and an arc-detector are implemented and controlled through a home-made rack in order to operate the klystron in safe conditions.

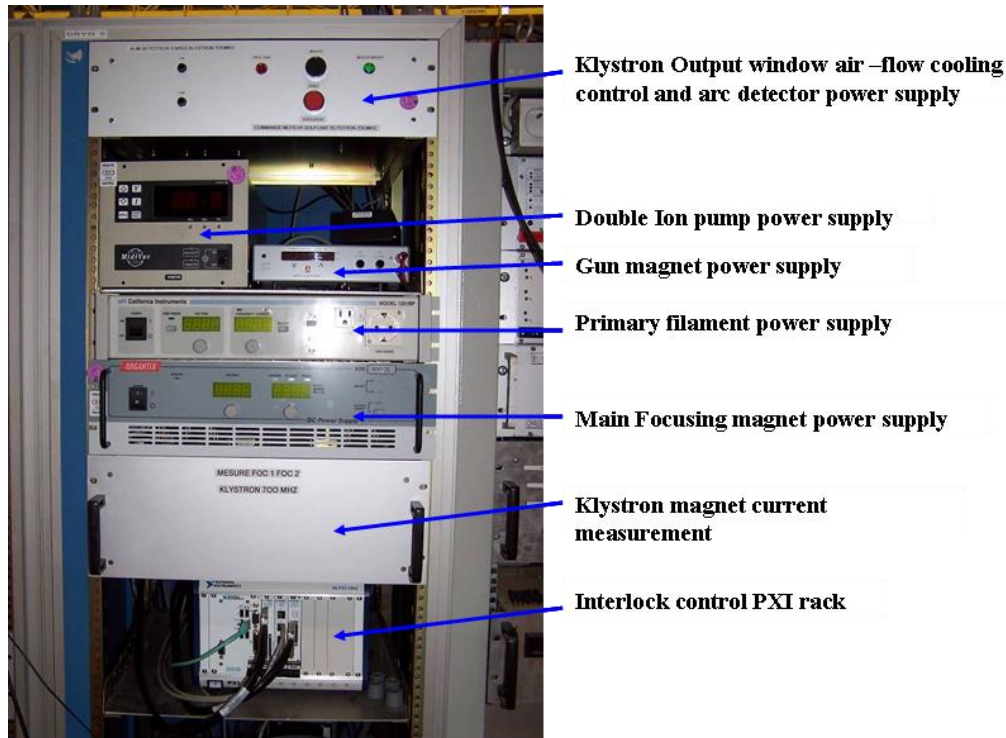

Fig. 7: 704MHz Klystron auxiliaries

The test stand also includes a PXI-based controller for the interlocks. The Labview PXI controller is designed to provide the following interlocks:

- Ion pump pressure,
- solenoids current and voltage
- primary filament current,
- water cooling pressure and temperature,
- HVPS failure,
- Modulator failure.

This system is composed with an FPGA card and is used as a fast interlock of the magnet current variations. This interlock is able to perform the detection and to switch off the HV pulse in $10\mu\text{s}$ if the coil current deviates more than $\pm 5\%$. Some other signals having slower variations (cooling system, klystron gun filament, pump pressure...) are also part of the interlock system, but they are scanned using the Real Time loop of the PXI controller.

Another controller system is foreseen for the automated RF acquisition on couplers, superconducting cavities and others components that are aimed to be used on the test stand. We already have a prototype with an industrial PC, three NI acquisition cards (2 NI PCI16MIO1, 1 NI PCIMIO16E10), one SCXI1000 chassis with three integrated modules (SCXI1100, SCXI1163 and SCXI1180 modules). A PCIGPIB card is also present to control devices with the IEEE488 protocol.

4) HV Cables

Due to the HV parameters of the klystron and HVPS, old HV cables were removed. The whole platform is equipped with new ESSEX-HV cables which have been successfully tested in AC mode. These high voltage cables (ref. A71004/07M ESSEX C2236) are designed to be used at voltage up to 225kV DC and 126 kV AC voltage, they are 7 metres long with 2 connectors (Yxlon R28 ESSEX) thus simplifying the plugging to the receptacle (S71001 ESSEX 225kV). The capacitive load has been measured to 900pF for each cable (positive, negative and output to klystron cables).

Two kind of tests were performed at the HV power supply factory to guarantee that either a short HV cable (5 m long) but also the connectors and receptacles can sustain a HV pulsed mode :

a) Inner and outer conductors connected to the high voltage AC (50Hz) power supply

U ac (kV)	I ac (mA)	Impedance (Ω)	Capacitance (F)	time (s)
100.3	4.78	2.10E+07	1.52E-10	10
140.9	6.86	2.05E+07	1.55E-10	10

b) Only inner conductors connected to the high voltage power supply, outer to the ground

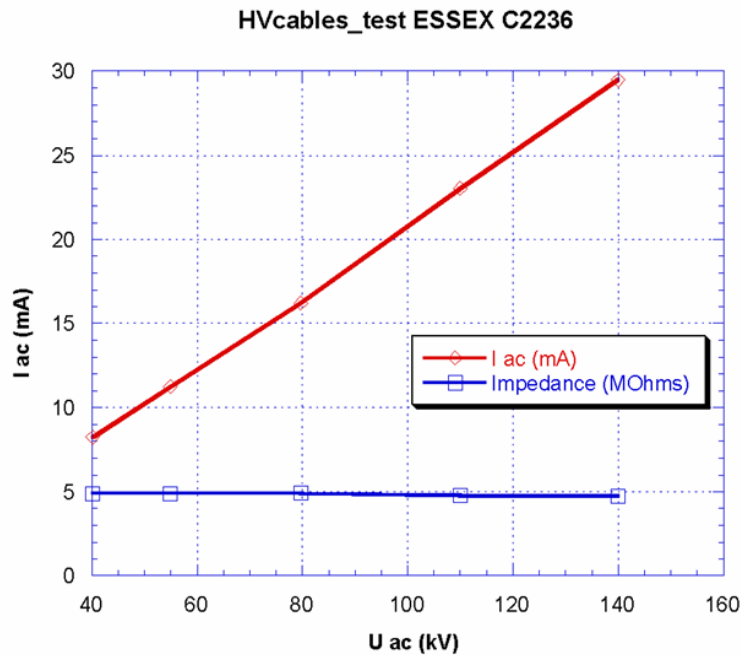

Fig. 8: HV Cable test up to $V_{ac}=140$ kV ; measured capacitance = 650 pF

The voltage was applied during 4 hours. During the tests no arcs were detected. The HV measurement with and without cables did not show any flagrant difference. The cables are able to sustain the HIPPI HV parameters.

HV and RF measurements

All the first tests were done with a RF load connected to the klystron RF output through a bi-directional coupler (Fig. 9).



Fig. 9: Klystron output with bi-directional coupler and RF load

The first tests of the cathode have shown that the current density from the cathode is stable when HV is increased, which is characterized by the constant perveance (Fig. 10).

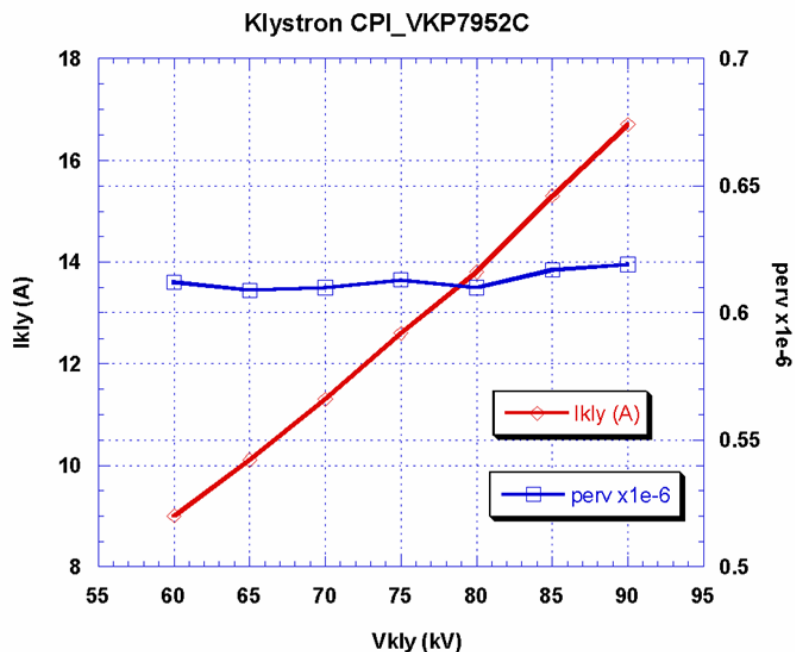

Fig. 10: Klystron microperveance

From the RF signal shapes (Fig. 11) measured at a 0.3Hz repetition rate, the klystron phase shift is about $10^\circ/\text{kV}$ at 92kV gun voltage, the HV ripple is lower than 100V at the beginning of the pulse from $t=0$ to $300\mu\text{s}$, and lower than 10V for $t>300\mu\text{s}$. The damped oscillation appearing when zooming the klystron current signal trace is due to klystron voltage feedback loop.

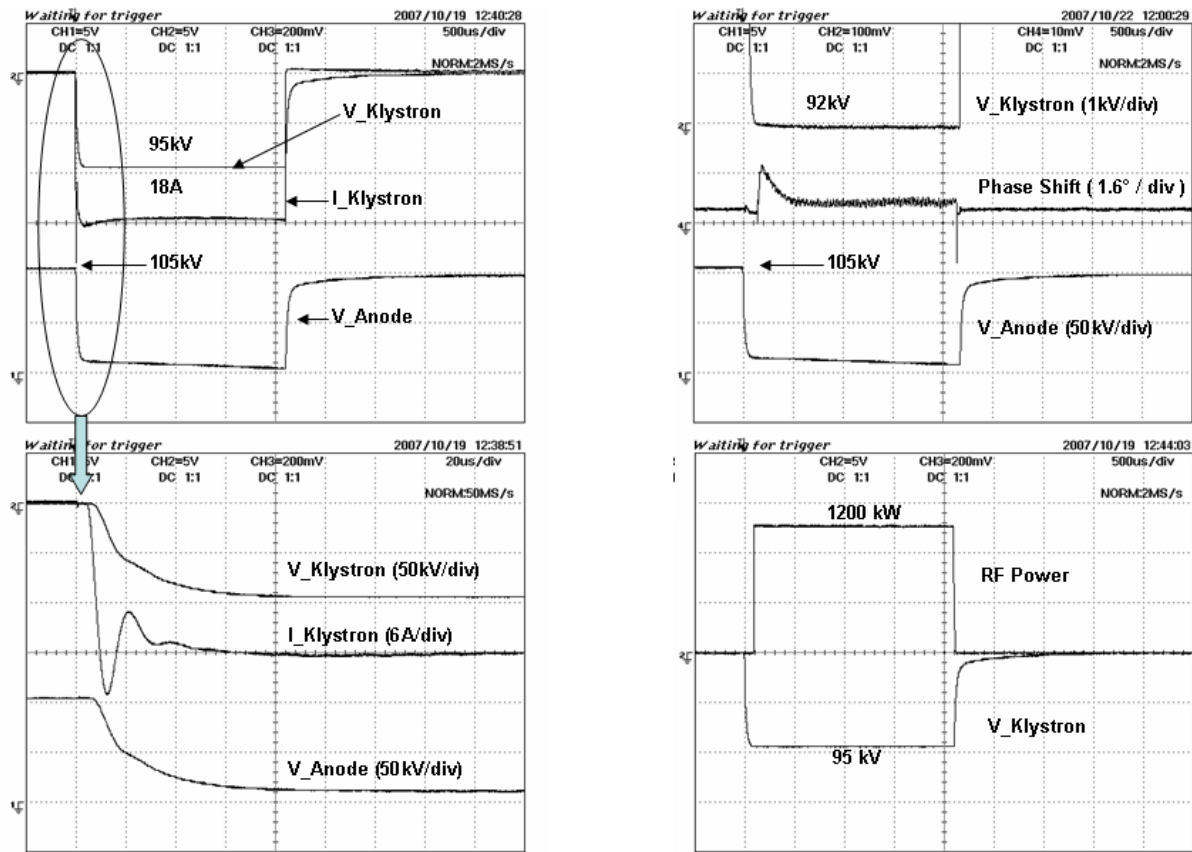

Fig. 11: Curves of klystron parameters (HV pulse=2.2 ms & RF pulse=2.0 ms)

Finally, the RF power was directly measured at the klystron output (Fig. 9). The first tests were performed at the nominal pulse length but with a reduced repetition frequency. With the maximum modulator settings ($V_{kly} = 95 \text{ kV}$, $I_{kly} = 18 \text{ A}$, 2.1ms HV), a 2ms 1.3 MW RF pulse was achieved from 703MHz to 705MHz and 1MW from 701.4MHz to 706.4MHz with a drive power range from 10 to 80W (Fig. 12).

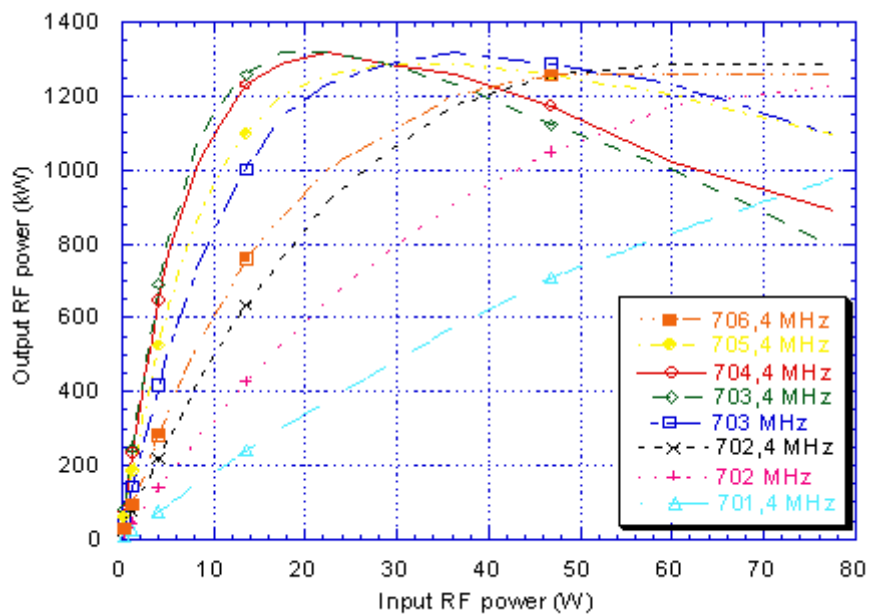

Fig. 12: RF power versus drive power at reduced repetition frequency

Conclusion

Measurements performed on the main components of the 1 MW-704 MHz RF test stand developed at CEA-Saclay show that the specifications (HV and RF power levels and pulse length) have been met at a reduced repetition rate. Since the HPVS is now repaired and tested, same tests at the nominal duty cycle will start.

Then, the klystron RF output will be connected to the waveguide network, in order to test and make the conditioning of all the other components (circulator, loads, couplers).

Acknowledgements

We acknowledge the support of the European Community-Research Infrastructure Activity under the FP6 “Structuring the European Research Area” programme (CARE, contract number RII3-CT-2003-506395). This work has been carried out using the SUPRA Tech GIS infrastructures with the financial support from Region d’Ile de France.

References

[1] ‘Conceptual design of the SPL II’, F. Gerigk *et al.*, CERN Report ref. CERN-2006-006, July 2006