

EU contract number RII3-CT-2003-506395

CARE-Report-2007-011-SRF

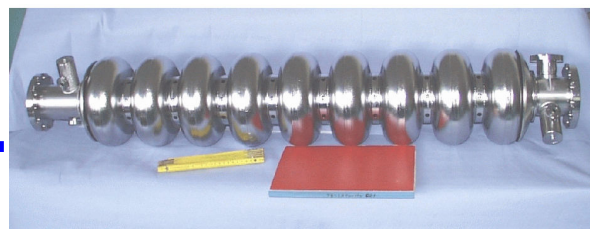

SRF



Research and Development on Superconducting Radio-Frequency Technology for Electron Linear Accelerators

Deliverable 5.4.2.4

Dry-Ice Cleaning: Report on Status of Parameters

D. Reschke, A. Brinkmann
DESY, Hamburg, Germany

Abstract

Dry-ice cleaning using the sublimation-impulse method removes particulate and film contaminations without any residues. The gases involved in this process, i.e. CO₂ and N₂ are chemically inert. Thus no negative impact on materials like niobium, copper, aluminium etc. used in a superconducting (s.c.) accelerator is expected. As high gradients in s.c. cavities require surfaces free of enhanced field emission, which is often caused by particulate contamination, the dry-ice cleaning process was applied to niobium samples and single-cell cavities. A dedicated cleaning apparatus for 1 – 3-cell cavities was constructed, commissioned and tested in the last years.

Introduction

A jet of pure carbon dioxide snow loosens and removes different types of surface contaminations by its unique combination of mechanical, thermal and chemical effects. The cleaning process acts local, mild, dry, without residues requiring no additional cleaning agent. The spontaneous relaxation of liquid carbon dioxide leaving the nozzle results in a snow/gas mixture with 45 % snow and a temperature of 194.3 K (-78.9°C). This jet is surrounded by supersonic nitrogen, which firstly gives acceleration and focussing of the jet and secondly prevents the condensation of humidity at the cleaned object. The cleaning effect is based on thermo-mechanical and chemo-mechanical forces. The former are created by three effects: brittling the contamination as a result of rapid cooling (shock-freezing), the tough pressure and shearing forces due to the high momentum of the snow crystals hitting the surface and the powerful rinsing due to the 500 times increased volume after sublimation. Particles down to 100 nm can be removed. Chemo-mechanical forces occur, when high momentum snow particles hitting the surface partially are melting at the point of impact. In its liquid phase carbon dioxide is a good solvent for non-polar chemicals, especially for hydrocarbons and silicones. The thermal effect of shock-freezing is thereby directly correlated with the snow intensity, while the mechanical effect however depends on the velocity and angle of the jet and the chemical effect depends on the momentum of the crystals. An optimal cleaning impact is achieved, if the thermal gradient between contamination and substrate is high. To avoid recontamination an effective and well-defined exhaust system is necessary. In summary the advantages of the carbon dioxide dry ice cleaning are:

- dry cleaning process,
- no cleaning agents,
- removal of particulate and film contaminations,
- no polluting residues.

The basic cleaning parameters are shown in Table 1 :

Table 1: Dry ice cleaning parameters

CO ₂ -pressure	~ 50 bar
N ₂ -pressure	12 – 18 bar
Particle filtration	< 0.05 µm
Temp. of liquid CO ₂	-5° - -40° C
Enviroment of cleaning	Laminar flow class 10

In order to achieve high gradients for future accelerators like XFEL, ILC, etc. without field emission loading advanced cleaning and handling procedures must be applied. Surface contaminations like particles, hydrocarbons, etc. and mechanical damages like scratches have been shown to cause enhanced field emission limiting the usable gradient of accelerating structures. Though high pressure rinsing with ultra pure water has been proven to be a powerful technique to reduce the enhanced field emission of cavities, dry-ice cleaning might have additional cleaning potential. Moreover it avoids a wet cavity surface with its enhanced sensitivity against recontamination. It should be applicable to ceramics (coupler windows) without loosing the gain of an earlier conditioning. Due to these properties dry-ice cleaning is considered as very attractive for the final treatment of horizontally assembled cavities with its power coupler.

Description of Work

After successful pre-tests on samples and cavities in 2002 and 2003 using the facilities of Fraunhofer Institute IPA, Stuttgart, Germany in early 2004 the infrastructure installation at DESY started. An ultra pure gas supply system for both carbon dioxide and nitrogen was integrated and successfully tested in the existing clean room (Fig.1). End of 2004 / beginning of 2005 the CO₂ cooler/purifier unit (Fig.1, 2) was ordered as an important component in order to filter, purify and liquefy the CO₂.

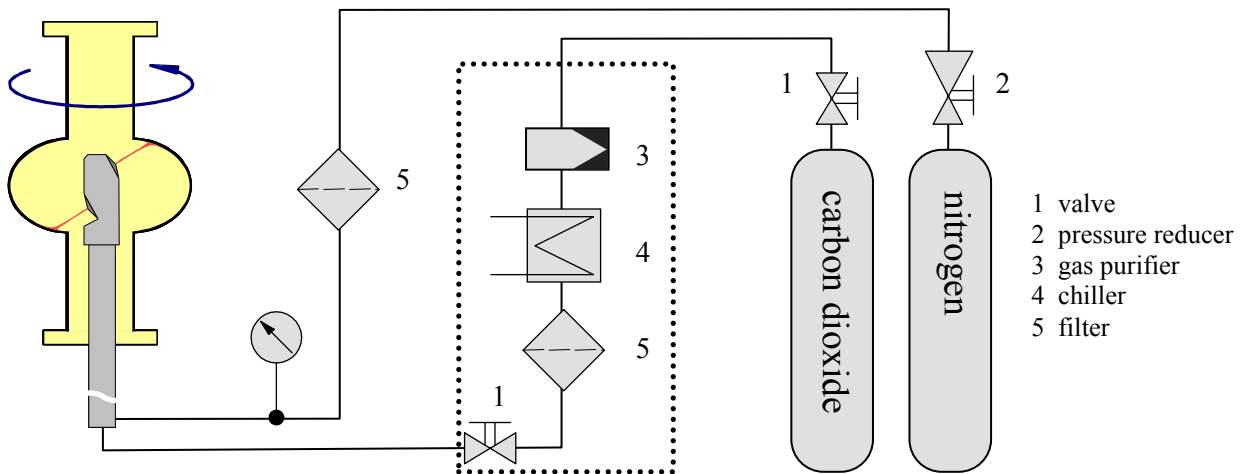

Figure 1: Schematic of the prototype set-up for dry-ice cleaning of monocell cavities

As described in the introduction dry-ice cleaning should be well suited for horizontal cleaning of s.c. cavities. Therefore the set-up for cleaning of 1-3-cell cavities was designed for horizontal cleaning differing from the proposal for task 5.4. In 2005 the horizontal motion unit using the existing spraying cane and a new motion unit started operation (Fig 2). Due to man power problems caused by unexpected repair work at the DESY accelerator HERA the complex control system of the cleaning unit was delayed significantly. This delay could not be compensated until today.



Figure 2: CO₂- cooler/purifier unit (left) and horizontal motion unit with the spraying cane assembled on the linear drive (right)

The heat removal from the cavity during operation of the dry-ice jet makes it necessary to apply a heater system to avoid cooling and freezing of the cavity. Several options have been considered. With respect to cleanroom requirements and simple assembly a prototype of an IR heater system was tested. After first operational tests it turned out, that the heating power was insufficient. Furthermore the assembly procedure after cleaning of the integrated heating and exhaust box was too complicated. A new dedicated design of an optimized, high power IR heater (Fig 3, 4) had to be developed, constructed and installed. This caused a delay during commissioning of app. six months. The new heater system fully meets its requirements and allows continuous dry-ice cleaning nearly without freezing of the cavity.



Figure 3: Dry-ice cleaning system with the new IR heater

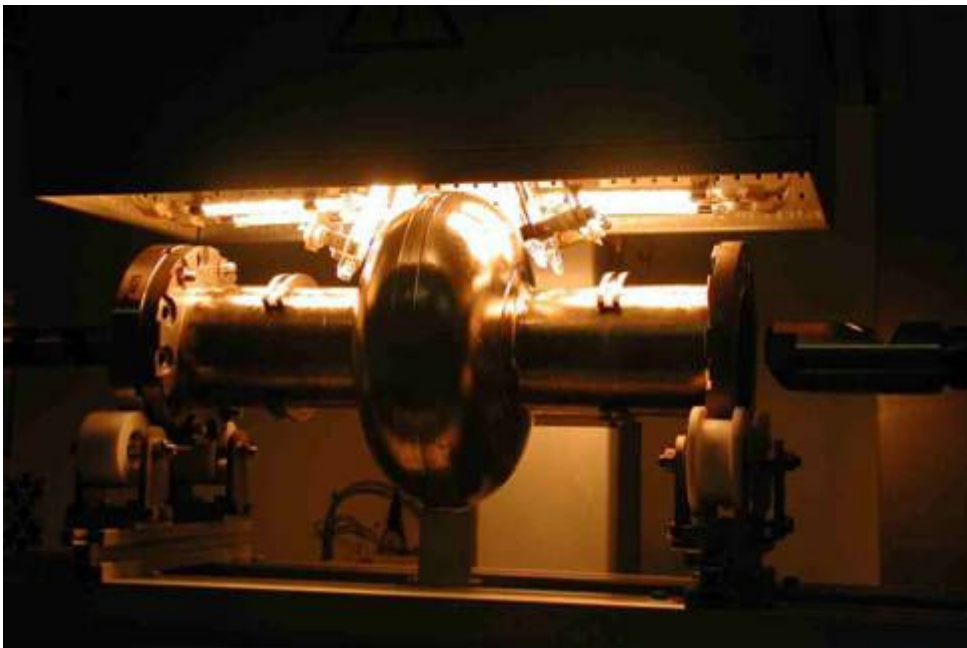

Figure 4: The new IR heater system in operation

To fulfil the requirements of personal safety for routine operation a gas alarm system was installed. During the installation phase the commissioning continued under special safety requirements.

Recently new capillaries with lower diameter have been tested in order to reduce the cooling of the cavity and the consumption of CO₂. The former is important to keep a high temperature gradient on the inner surface for an optimum cleaning efficiency (see Introduction). A reduced CO₂ consumption enhances the usable time of one set of pressure bottles and is in general preferable with respect to safety aspects. A capillary with 12% reduced diameter is used since Nov 2006. Furthermore the assembly procedure of the cavity to its vacuum and rf connection (“antenna”) is improved by a simple, but effective new fixture.

In 2005 and 2006 the commissioning of the dry-ice cleaning system was continued successfully (Fig. 5). Several cavities are cleaned both for system tests and for rf measurement of the cavity. Additional samples have been cleaned and tested (WP 6.3). The cleaning parameters and cavity results are discussed in the next chapter.



Figure 5: Commissioning of the dry-ice system: Optical checks of the jet under different conditions

Discussion of Work

The dry-ice cleaning system is operable and a preliminary cleaning parameter set is fixed. With respect to the results still there is a contradiction between excellent cleaning results on samples (Tab.1 WP6.3.) compared to most of the cavity tests still suffering on field emission loading (Fig 6). The reason can be either the cleaning parameters or a contamination of the cavity during the final assembly after the dry-ice cleaning. After the recent modification of CO₂ – capillary and assembly fixture an excellent cavity result with no field emission loading up to 33 MV/m was achieved (Fig. 7). The goal of the next tests will be the reproduction of this result.

Treatments on Nb	EP	EP + HPR	EP + HPR + Dry-ice
Eonset (1 nA)	40 MV/m	60 MV/m	90 MV/m
N @120 MV/m	30 / cm ²	14 / cm ²	< 2 / cm ²
β values	(31-231)	(17-167)	(17- 80)

Table 1: Improvements on EP Nb samples after HPR and DIC (WP 6.3)

In spite of this good result the preparation of the construction of the nine-cell cleaning apparatus requires a careful re-investigation of the nozzle system and cleaning parameters together with the dry-ice cleaning experts of the Fraunhofer Institute for Manufacturing Engineering and Automation (Fraunhofer IPA, Stuttgart). This will take until mid of 2007. In addition further sample measurements on various niobium materials are on the way in close collaboration with WP 6.3.

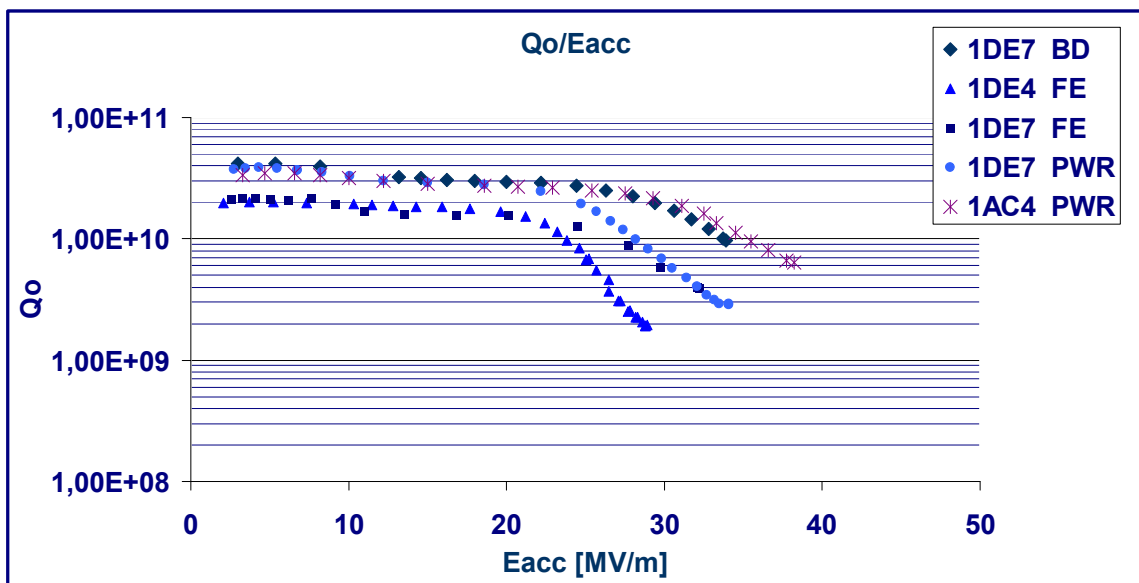

Figure 6: $Q_0(E_{acc})$ -performance of latest rf-tests after dry-ice cleaning

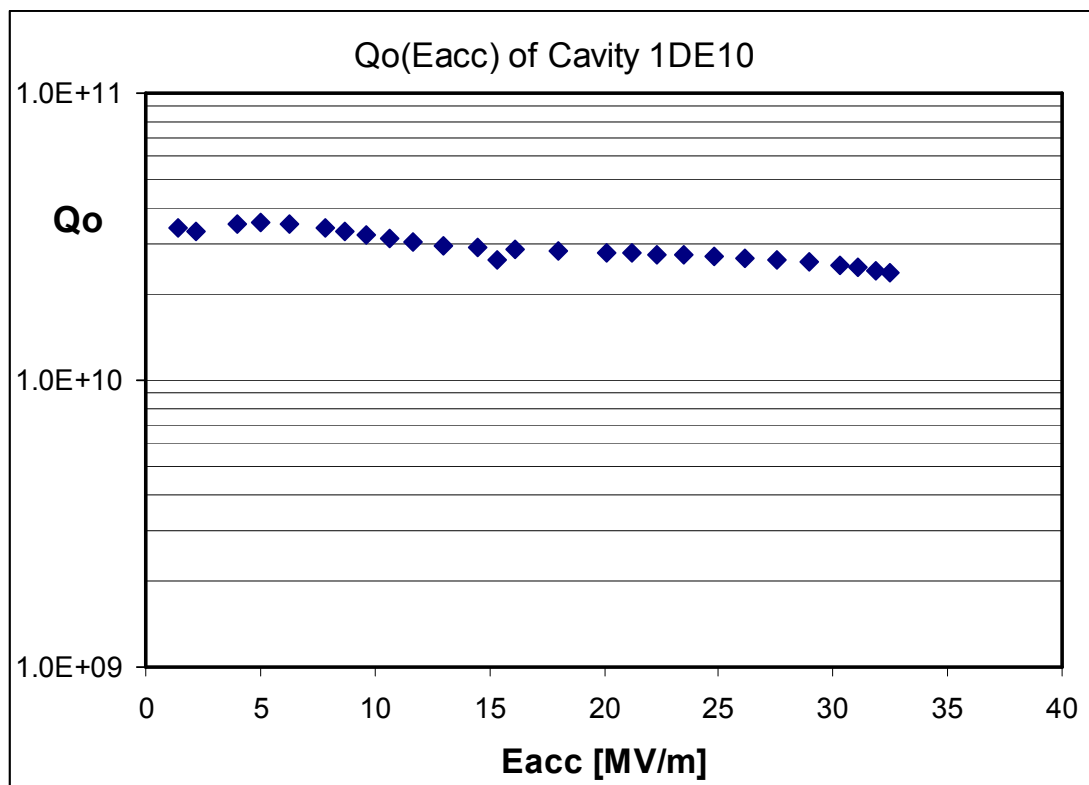

Figure 7: Recent best $Q_0(E_{acc})$ -performance after dry-ice cleaning with new capillary

Conclusions and Future

The dry-ice cleaning has shown its capability for successful cleaning of samples and SRF single-cell cavities. Nevertheless the results are not as reproducible as necessary for multicells applications.

Next steps in the near future will be the above described evaluation of the cleaning parameters and the understanding of critical conditions during cavity cleaning. More cavity tests are

necessary in order to confirm and to optimize the preliminary cleaning parameter set. Though the multi-cell cleaning apparatus is significantly delayed, this is a necessary precondition for the successful construction of the next generation set-up. Reproducibility of the cavity cleaning is a must for the envisaged applications.

Only minor technical modifications of the existing apparatus are planned. An additional heater of the gas pressure bottles will avoid the cool down of the bottles in order to stabilize the CO₂ pressure during operation.

Acknowledgements

We acknowledge the support of the European Community-Research Infrastructure Activity under the FP6 “Structuring the European Research Area” programme (CARE, contract number RII3-CT-2003-506395).

The authors thank A. Guss, C. Rudat, S. Wieggers, J. Ziegler and all involved DESY colleagues for their help. The technical support of R. Grimme, D. Werner and C. Zorn of the Fraunhofer IPA, Stuttgart is of fundamental importance for our work. Thanks for many fruitful discussions to A. Pandey and G. Müller, University of Wuppertal.

References

- 1) “Dry-ice cleaning for SRF Applications”, D. Reschke et al., Proc. of the 9th Workshop on RF superconductivity, KEK Proc. 2003-2, Tsukuba-shi, Japan (2003)
- 2) “First experience with dry-ice cleaning on SRF cavities”, D. Reschke et al., Proc. Of the LINAC 2004, Lübeck, Germany (2004)
- 3) Presentation at the ELAN Meeting, May 4th – 6th 2004, Frascati, Italy
- 4) “Further improvements with dry-ice cleaning on SRF cavities”, A. Brinkmann et al., Proc of the 11th Workshop on Rf superconductivity, Cornell, USA (2005)
- 5) “Dry-ice cleaning on SRF cavities”, A. Brinkmann et al., Proc. of the EPAC 2006, Edinburgh, Great Britain (2006)
- 6) Reports of CARE SRF WP6.3, G.Müller, University of Wuppertal