

EU contract number RII3-CT-2003-506395

CARE-Note-2007-011-SRF

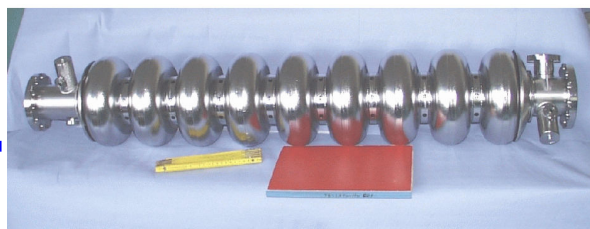

SRF



## Lorentz detuning compensation of a 9-cell TTF cavity with the integrated piezo tuner at Saclay

G. Devanz<sup>1</sup>, P. Bosland<sup>1</sup>, M. Desmons<sup>1</sup>, E. Jacques<sup>1</sup>, M. Luong<sup>1</sup>, B. Visentin<sup>1</sup>, M. Fouaidy<sup>2</sup>

1) CEA-Saclay, 91191 Gif-sur-Yvette Cedex, France

2) IPN-Orsay, 91406 Orsay Cedex, France

### Abstract

A new cold tuning system with integrated piezo elements has been developed at Saclay. Two prototypes have been built. One of them has been mounted on a 9-cell TTF cavity equipped with a TTF-III input power coupler. The assembly was installed in the Saclay horizontal test facility CRYHOLAB for a full characterization. The compensation of Lorentz force detuning (LFD) was achieved at  $E_{acc}=25$  MV/m for a 200  $\mu$ s rise time and 800  $\mu$ s flat top RF pulse. The compensation experiment could not be carried out at higher gradients due to field emission in the cavity.

## 1 The PTS cold tuning system

### 1.1 Mechanical assembly

The new Piezo Tuning System (PTS) tuner is based on the lever arm design already used for the current Saclay tuner which is operating at TTF since 10 years. The static tuning is obtained with the combination of the lever arm and a screw which is driven by a stepper motor and a gear box. One of the tuner arms is equipped with two piezoelectric elements which provide the fast tuning. The whole system operates in vacuum at liquid He temperature. The cavity is acting as a spring on the PTS in order to generate a compression force on the piezo elements, which is mandatory to maintain their mechanical integrity during their active operation. Figure 1 shows the PTS and its mounting position on the He tank. The piezo arm is designed in order to minimize the shear stress in the piezo regardless of the static tuning setup.

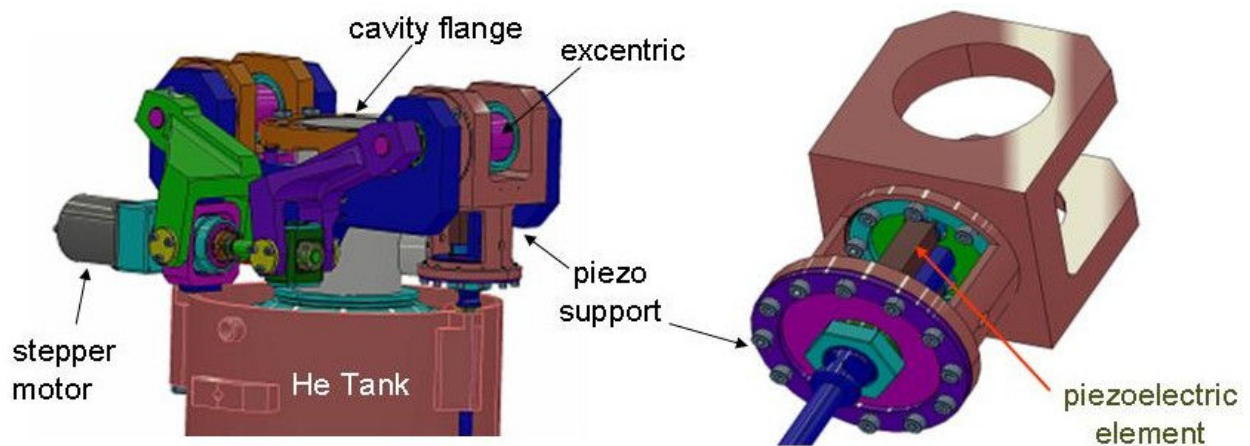

Figure 1: The PTS cold tuning system

### 1.2 Piezoelectric elements

The piezoelectric elements are NOLIAC 30 mm long stacks. They are meant to be operated in elongation mode, with a positive voltage up to 200 V. Their characteristics are well known at room temperature, but their electromechanical properties at 2 K were not known at the time of the mechanical design of the PTS. The measurements of these properties are the subject of another study in CARE-SRF WP8. The critical parameter for PZT operation is their mechanical preload. It has to be positive (compression) and lower than the blocking force (6000 N at room temperature). We rely on the spring force of the elongated cavity to provide the piezo elements with a sufficient preload. The combination of contraction coefficients of different materials of the tuner, cavity and He vessel, a large positive tuning range is necessary to achieve a preload of several hundred Newtons on the PZTs. The yield stress of Nb is much higher at LHe temperature (300 MPa) than at room temperature (40 MPa), therefore the cavity can be stretched by 3 mm without damage provided it is cold. The limitation on the preload at 2 K comes from the mechanically achievable range of the PTS itself, which is determined by the useful length of the main screw.

## 2 Room temperature tests

### 2.1 Stiffness

The tuner stiffness has been estimated using a pneumatic jack and 0.01 mm accuracy indicators. For the first measurement the stiffness was 35 kN/mm, showing that the weakest parts were the ball bearings. Another measurement on the second PTS prototype yielded 70 kN/mm after a linkage rod was added between the two eccentric stems.

### 2.2 Piezo-to-piezo transfer function

The PTS was mounted on the C45 9-cell cavity. In order to provide the preload force, the cavity was elongated by 1mm which is still within the elastic region. The estimated force is 500 N on each piezo. The transfer function (TF) was first measured on a granite bench (Fig. 2) using a sinusoidal excitation on one PZT and stepping the excitation frequency. The amplitude and phase of the response of the second PZT is measured with a lock-in amplifier.

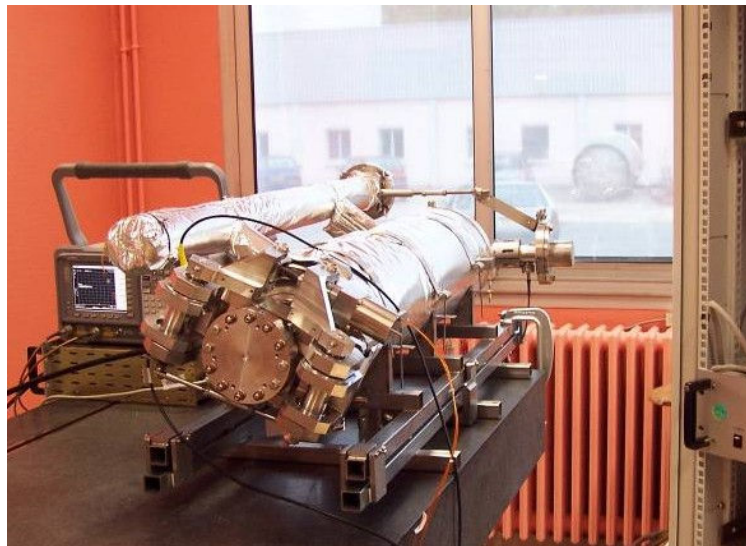

Figure 2: Test setup for room temperature transfer function measurements

The installed PZTs are labeled #8 and #9. The transfer function from #9 to #8 is shown in figure 3.

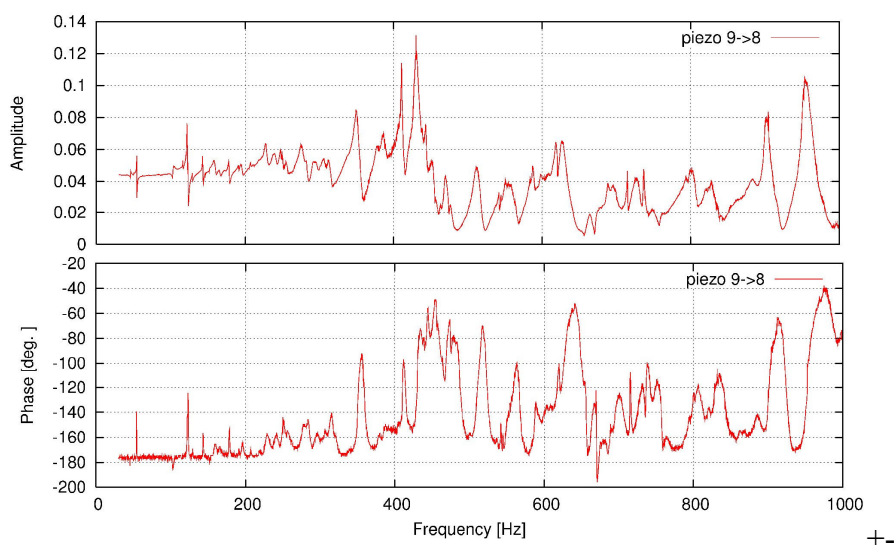

Figure 3: PZT #9 to PZT #8 transfer function

The transfer function  $H(9 \rightarrow 8)$  displays a lot of resonances. Some of them have a high quality factor  $Q_m$ . The transverse mode at 54 Hz was measured in time domain to determine its decay time. Its corresponding  $Q_m$  is 200. The  $H(9 \rightarrow 8)$  and  $H(8 \rightarrow 9)$  transfer functions are almost identical, however, the amplitude of several resonance differ from 20 %. The coupling to the bearing balls provides a loss mechanism: most of the balls move freely within the bearing until they hit the bearing wall or an adjacent ball and generate acoustic noise which can be clearly distinguished from the sinusoidal excitation on large frequency spans above 400 Hz.

### 3 Room temperature measurements in CRYHOLAB

The cavity was installed in the Saclay horizontal test cryostat CRYHOLAB (fig. 4).

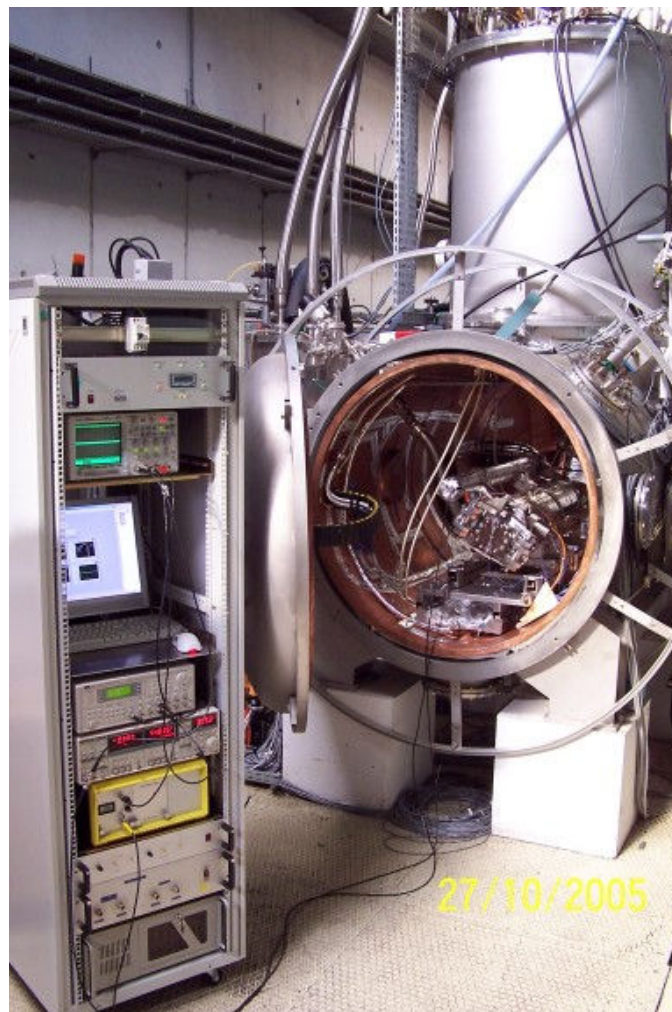

Figure 4: 9-cell cavity in CRYHOLAB and instrumentation

Before the cooldown, PZT to PZT transfer function measurements were repeated to investigate possible influence of the multiple connections between the cavity and the cryostat: fundamental power coupler, cavity support, RF cables, cryogenic connections, cooling braids and magnetic shielding.

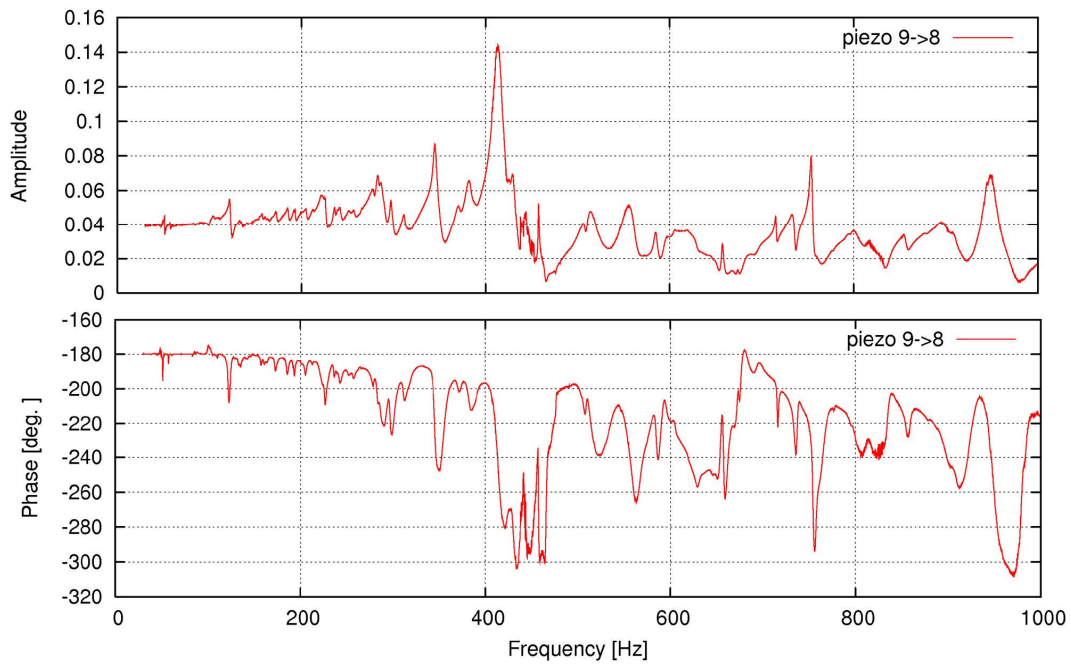

Figure 5: H(9->8) transfer function at 300K in CRYHOLAB

The general behavior of H(9->8) is the same (Fig. 5), but most resonances have a reduced quality factor when measured in CRYHOLAB. The behavior is mostly different around 400 Hz.

The transfer function  $H(9 \rightarrow \Delta f)$  relating the piezo excitation and the cavity detuning was measured using a dedicated phase demodulation rack. With piezo excitation voltages of the order of 1 V, the expected displacement at 300 K is of the order of  $0.1 \mu\text{m}$  which should reflect in cavity detuning of the order of 30 Hz. This is negligible with respect to the 300 K bandwidth of the cavity, which is 10 kHz from the measurements. If the cavity is fed with an RF synthesizer at its rest resonant frequency  $f_0$ , a mechanical frequency modulation of the cavity should then generate a phase modulation but no amplitude modulation of the transmitted signal. The phase demodulation scheme is shown in figure 6.

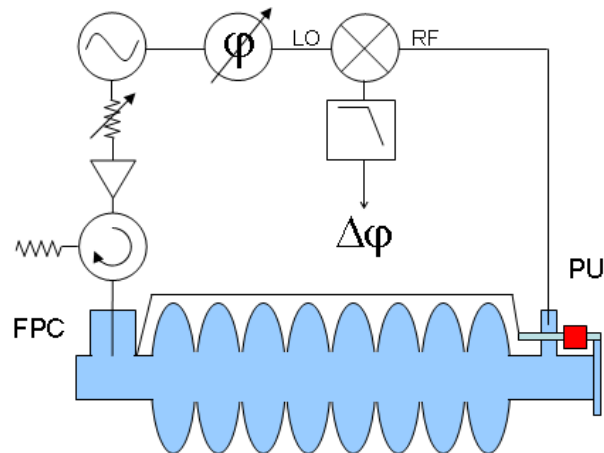

Figure 6: phase modulation measurement setup

The mixer output signal is in the mV range which is the same order of magnitude than the noise. Therefore synchronous detection was performed with a dual channel lock-in amplifier, which is very efficient in extract the sinusoidal signal from the noise. The measured transfer function is shown in figure 7.

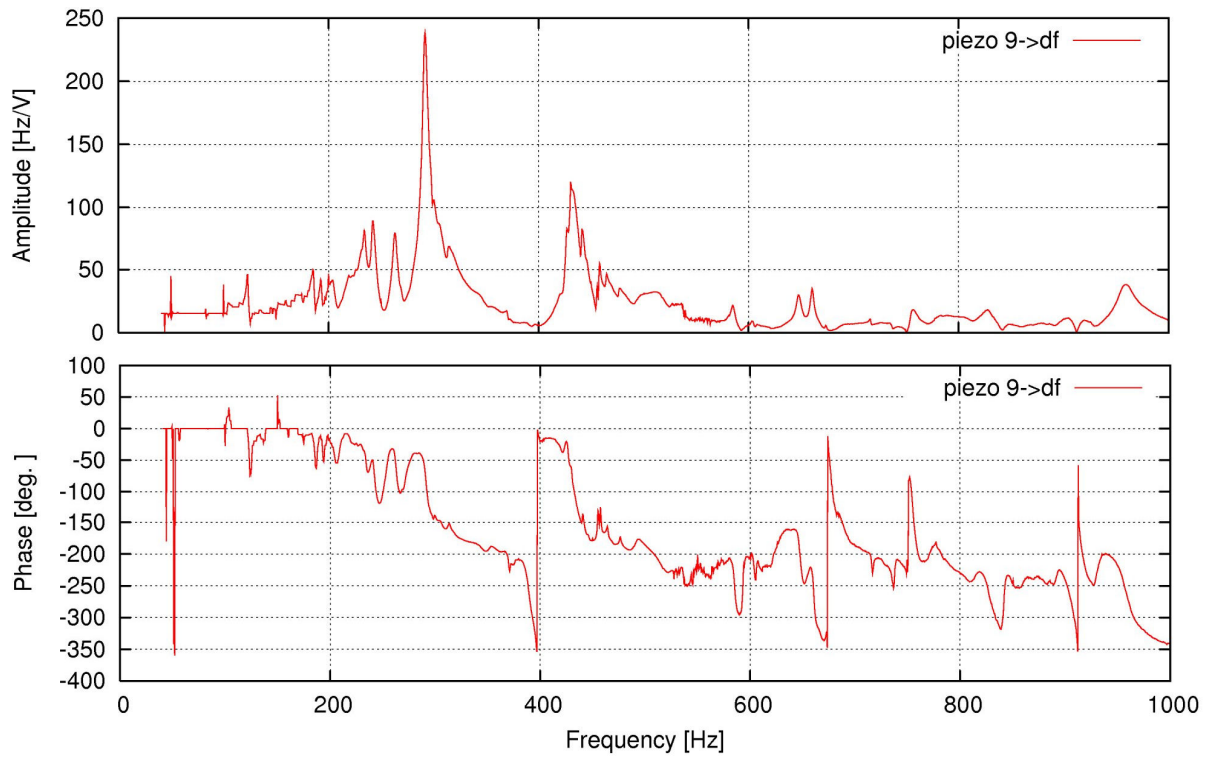

Figure 7 : H (9  $\rightarrow$   $\Delta f$ ) transfer function at 300 K

The dominant resonances in H(9  $\rightarrow$   $\Delta f$ ) are obviously not the same as for PZT to PZT transfer functions. For instance, the strong resonance at 292 Hz which can be observed in figure 7 does not stand out in the H (9  $\rightarrow$  8) measurement. It means that the corresponding mechanical mode is not driven very efficiently by the PZTs, but also that its coupling coefficient to the RF detuning is very high since a weak excitation of the mode generates a large detuning.

#### 4 Continuous mode measurements in CRYHOLAB at 1.8 K

##### 4.1 Cooldown

The PTS was connected to a phase separator by means of five copper braids in order to speed up the cooling. Thermal sensors were installed on the stepper motor and on each of the two PZTs stainless steel spherical heads. The temperature of the PZTs was higher than 20 K during all the 1.8 K measurements.

##### 4.2 Tuning range

During the first experimental run, the PTS was equipped with its original main screw and the 300K neutral point of the tuner was set within the tuning range of the motor. At 1.8K the cavity could be tuned from 1300.320 MHz up to 1300.590 MHz. The cooling of the cavity is expected to reduce the preload of the PZTs, and the highest preload is obtained for the

maximum cavity elongation. Therefore in the second experimental run, the 300K neutral point was set below the minimum frequency position of the tuner, and the main screw was replaced with a longer one in order to increase the tuning range towards higher cavity frequencies. With this setup, the slow tuning range was extended to 530 kHz at 1.8K (positive tuning only). In the first case, the tuning curve displays two distinct slope changes. This can be correlated to successive temperature changes on the piezos, and interpreted as a modification of the mechanical contacts between the PZTs and their support, and indicates a bad setup of the preload. In the second experiment with the longer main screw, only one of the slope changes could be observed on the tuning curve at 1.8 K. One of the piezos (#9) located on top position in the PZT support was chosen as the actuator for all the subsequent experiments, for its temperature was in all cases lower than PZT #8 indicating a better mechanical contact with the support and a higher mechanical preload than PZT #8.

#### 4.4 Piezo to detuning transfer function at 1.8 K

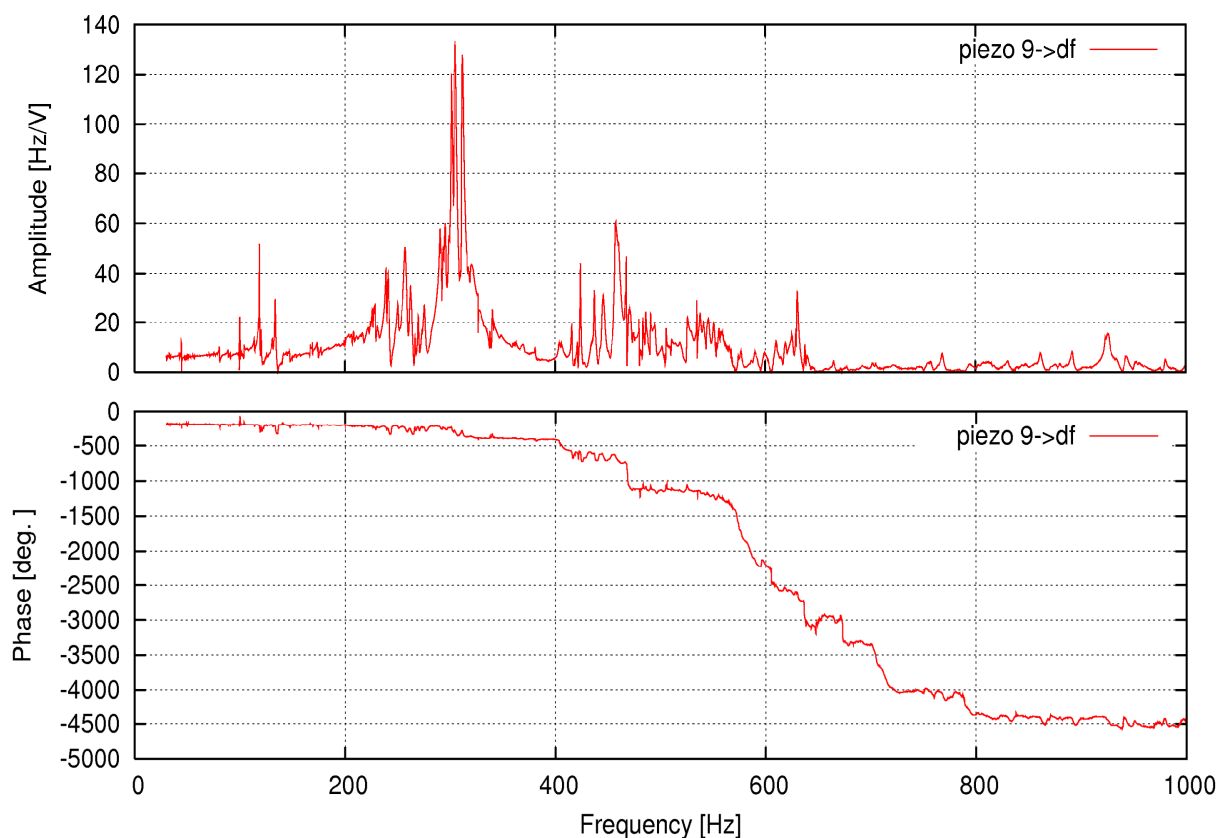

Figure 8:  $H(9 \rightarrow \Delta f)$  transfer function

This transfer function greatly differs from its 300 K counterpart which can be understood from the different mechanical loading of the whole system. More interesting is the change between the 1.8 K TF and its 4.2 K counterpart. This high sensitivity of the transfer function with respect to temperature is still not fully understood but the obvious change on a mechanical standpoint is the different mechanical coupling between the cavity and the fluid inside the He vessel: atmospheric pressure liquid He at 4.2 K and low pressure superfluid He at 1.8 K. The dominant mode at 1.8 K is around 300 Hz and experiments with pulsed RF will confirm that this mode is strongly coupled to the cavity detuning. The phase of the TF at low

frequency is changing linearly with frequency, which indicates a constant time delay in the system which is about 400  $\mu\text{s}$  in our case.

## 5 Pulsed mode measurements in CryHoLab at 1.8 K

### 5.1 Coupling measurements

The calibration of the different couplings between the cavity and the RF network was carefully measured with a network analyser. The external Q of the fundamental power coupler (FPC) is  $Q_i = 1.34 \cdot 10^6$ , using the -3 dB bandwidth of the  $S_{21}$  measurement between the WR650 waveguide to N transition connected to the doorknob and the pickup cable. This value has been cross-checked with the cavity filling time. The external Q of the pickup ( $Q_t$ ) can be derived from the maximum amplitude of  $S_{21}$ , after in-situ calibration of the attenuation of the cable which transmits the signal from the pickup to the outside of the cryostat. Its value is  $Q_t = 3.4 \cdot 10^{11}$ . This value is used as a reference for subsequent accelerating field measurements.

### 5.2 Pulsed measurements on the cavity.

The high power RF system at the CryHoLab facility is able to provide a peak power of 1.5 MW with a pulse duration of 1 ms, and a maximum repetition rate of 6.25 Hz. In order to study the pulsed behavior of the cavity similar to what could be observed on an accelerator, a flat top has to be obtained on the accelerating field  $E_{\text{acc}}$ , which is monitored through the transmitted power at the pickup  $P_t$ . In the present experiment, since no beam is available to provide the cavity loading and the subsequent flat-top, this condition has to be obtained by shaping the incident RF pulse. This can be achieved in CryHoLab since the input power ( $P_i$ ) available is 7 times higher than the input power needed to maintain the maximum field in the C45 cavity, namely  $P_{25} = 120 \text{ kW}$  for  $E_{\text{acc}} = E_{\text{max}} = 25 \text{ MV/m}$ , just below the onset of field emission. The loaded Q of the cavity implies a time constant  $\tau$  of 0.33 ms. If at the beginning of the RF pulse 4 times  $P_{25}$  is fed to the cavity, aiming at  $E_{\text{acc}} = 2 E_{\text{max}}$ , at  $t_{1/2} = \tau \ln 2$ ,  $E_{\text{acc}}$  amounts exactly to  $E_{\text{max}}$ . At this time if the RF power is switched to  $P_{25}$ ,  $E_{\text{acc}}$  is maintained constant in the cavity to its value  $E_{\text{max}}$ . This pre-pulse method enables to tailor the time profile of the field using only two parameters  $t_{\text{pre}}$  and  $P_{\text{pre}}$  (fig. 9).

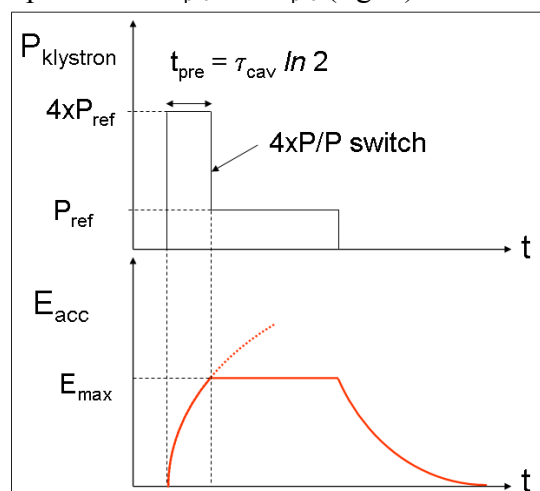

Figure 9: RF pulse shaping method



Since the cavity is overcoupled, the time  $t_{1/2}$  corresponds also to the cancellation of the reflected power  $P_r$ , which is the parameter we have monitored for the experimental determination of  $t_{pre}$ . In reality, the Lorentz detuning prevents  $E_{acc}$  from remaining constant if no active compensation is carried out, but the proper shape of the RF input pulse to obtain a flat top in absence of Lorentz detuning can be obtained at low field. This pulse setup phase can be carried out at a low value of  $E_{acc}$  to be more accurate. We have obtained a flat top of 780  $\mu$ s using this method.

The klystron is equipped with an amplitude stabilization loop, but no phase feedback. The pre-pulse operation generates a fast phase shift during the 4xP/P switching which is compensated using a synchronized voltage controlled phase shifter in front of the klystron preamplifier. The residual klystron phase shift during the pulse is about 5 degrees.

At  $E_{acc} = E_{max} = 25$  MV/m, the phase of the cavity shifts by 30 degrees. The detuning of the cavity is not measured directly, but the RF signals have to be compared to the results of a Matlab simulation of the pulsed RF behaviour to obtain the detuning. This model includes the effect of Lorentz detuning on a finite number of mechanical modes. The frequency and quality factors of the modes are known from the TF measurements. The parameters which have to be adjusted are the Lorentz coefficients  $k_m$  of these modes and the initial detuning of the cavity. The actual phase and amplitude of the forward RF pulse measured at the power coupler is fed to the model, and the Lorentz coefficients are varied until the computed phase and amplitude of  $P_t$  fit the measured ones. Using this method, the detuning of the cavity during the flat top is estimated to  $\Delta f_{25} = -240$  Hz. For consistency, the sensitivity of this result with respect to the coefficients, initial detuning and mechanical Q ( $Q_m$ ) has been checked. It comes out that on the short time scale of 1 ms, the simulated RF signals are more sensitive to the initial detuning and the mechanical Q than the  $k_m$ .

Another simulation effort has been carried out to predict the dynamic detuning of the cavity using coupled mechanical and RF finite element computations. The mechanical part is computed with the CASTEM code from CEA. The RF surface fields are computed with SUPERFISH. They are used to generate the radiation pressure distribution and to compute the detuning with the Slater method. The parameters of the model are the stiffness of the tuning system (to which has been assigned the measured value of 35 kN/mm) and the  $Q_m$  of the modes. The limitation of the model comes from the mode truncature (here  $N_{modes}=40$ ) the hypothesis of cylindrical symmetry, the absence of fluid loading by helium. The computed values obtained for the detuning during the flat top with the CryHolab RF pulse are ranging from -200 to -250 Hz when varying the  $Q_m$  of all modes from 50 to 100. This is also consistent with what has been discussed before.

#### 5.4 Lorentz detuning active compensation.

During all the experiments, the frequency of the RF generator is fixed, Lorentz detuning can be diagnosed by amplitude and phase modulation of the transmitted signal during the flat top. Since the Lorentz detuning exhibits a high reproducibility from pulse to pulse, compensation is obtained through a feed-forward scheme, by manually adjusting the piezo driving signal so as to obtain a flat phase and amplitude response on the pickup signal during the 800  $\mu$ s flat top. Successful compensation could be achieved with a simple piezo driving signal, which consists of a trapezoidal pulse. The parameters were the amplitude, rise time, and time advance with respect to the RF pulse. Since the RF repetition rate was low, 0.87 Hz, the duration of the piezo pulse was of low importance, as long as it was no shorter than 1 ms and small compared to the pulse to pulse period of 1.15 s. The compensation at  $E_{acc} = 25$  MV/m

was achieved for a piezo pulse with the following characteristics: amplitude 42 V, rise time 200  $\mu\text{s}$ , time advance 500  $\mu\text{s}$ . The peak-to-peak cavity voltage phase excursion during the flat top is reduced from 30 degrees without compensation to 3 degrees with the optimal piezo pulse. The experimental data are shown in figure 10.

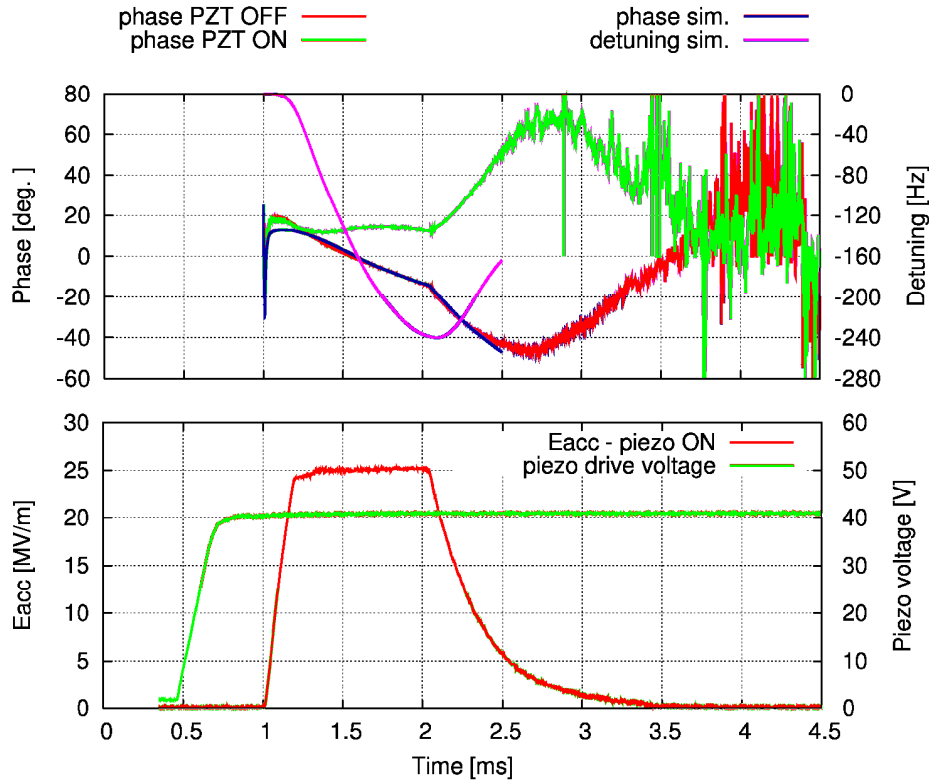

Figure 10: Lorentz force detuning compensation

The accelerating amplitude is constant during the flat top of the RF pulse thanks to the LFD compensation. The time advance needed here is related to a delay in the mechanical system (cavity and tuner) and a propagation time of the mechanical pulse in the cavity which have to be compensated for an effective LFD cancellation. The delay can be derived from the transfer function shown in figure 9 using the slope of the phase with respect to the frequency in the low frequency. Using this method, the experimental value of the mechanical delay is 400  $\mu\text{s}$ . Another way to measure this delay is to monitor the effect of the Lorentz force pulse on the piezo actuator, which is used as a sensor.

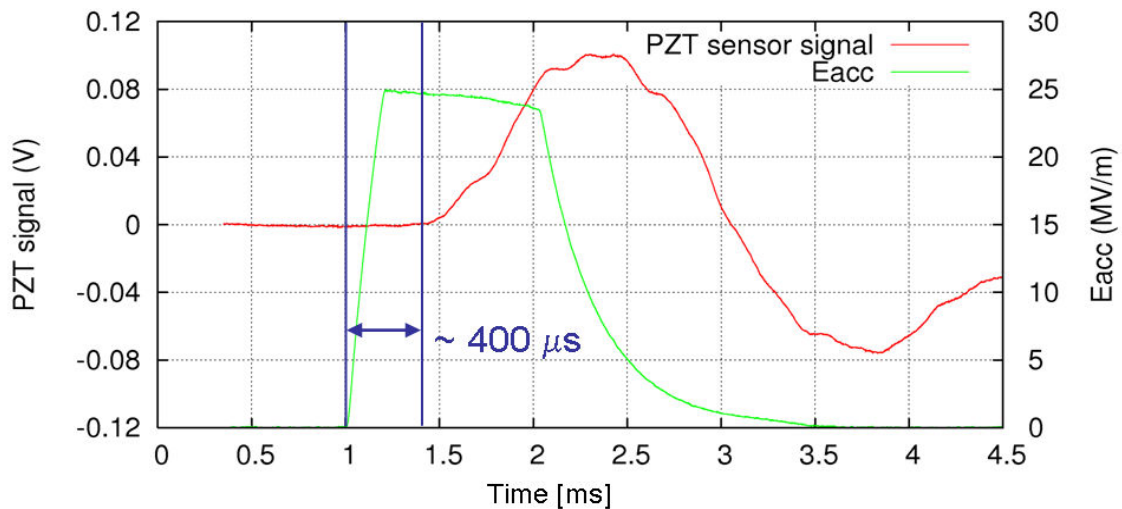

Figure 11: Direct measurement of the mechanical delay in the cavity-tuner system.

The measurement is shown in figure 11. The delay between the start of the RF pulse and the voltage response of the PZT #9 is 400  $\mu$ s. These data correspond to a case without LFD compensation, and the effect of the detuning is obvious on the recording of the accelerating field, which drops by 8 % during the flat top.

The PZT signal is also obviously dominated by a frequency around 300 Hz, which is a clear indication that the 300 Hz mode is strongly excited by the radiation pressure distribution. The PZT #9 signal has been acquired for a single RF pulse during 1.2 s and split into 3 sections of 400 ms each. For each of these 3 parts, the Fourier transform was computed to analyse the spectral evolution of the signal.

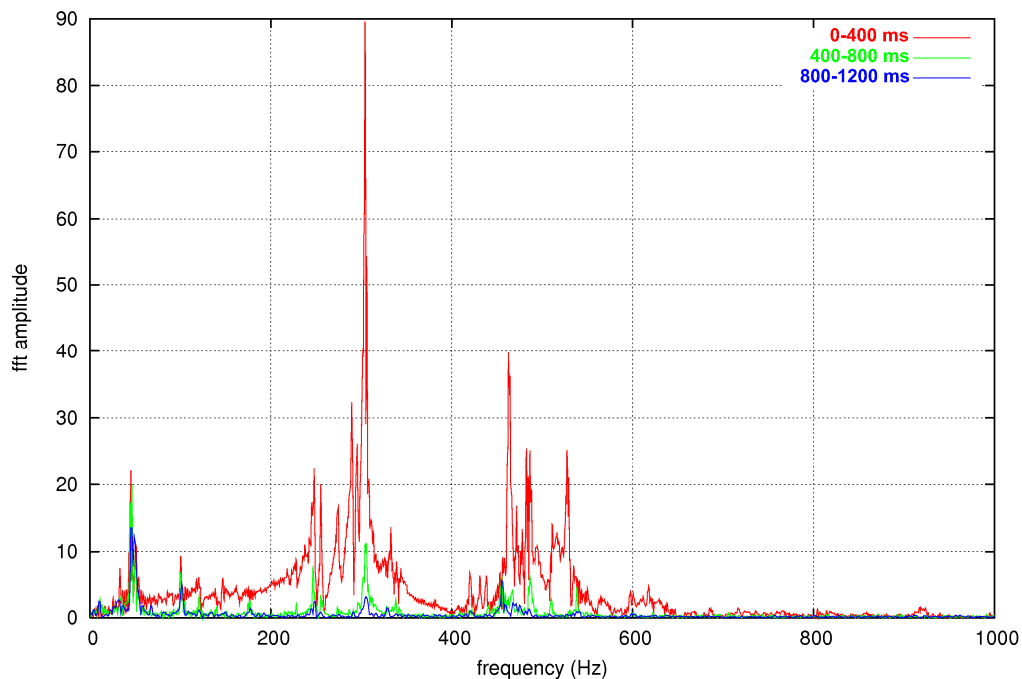

Figure 12: Spectral evolution of the PZT sensor voltage for a single RF pulse ( $E_{acc} = 25$  MV/m)

The result is shown in figure 12, where the 304 Hz line stands out clearly. Most of the Lorentz induced signal is included in the first 400 ms, while the last part is dominated by microphonics. The spectral lines which stay at a similar amplitude in the 3 sections correspond to mains hum and harmonics 50 Hz and 100 Hz, and mechanical modes which are permanently excited by external disturbances, here 45 Hz for example. Notice this is not a microphonics measurement, since detuning is not measured here. Microphonics have been measured for the same setup in CryHoLab, which is reported in [5]. The resonant behaviour of the mechanical mode is clearly revealed in the intermediate 400-800 ms section: in particular, the some energy is still present in the 304 Hz mode after 400 ms, which is also the case for the 247 Hz, 460 Hz and 487 Hz lines.

## 6 Tests with PICMA PZTs

All the tests in CryHoLab have been reproduced using a pair of different PZT stacks from PICMA provided and characterised by IPN/Orsay [6-7]. They can sustain a maximum voltage of 150 V, the active stack is thus longer (36 mm) to achieve a stroke similar to what the 30 mm NOLIAC stacks are able to provide. The piezo support accepts these PZTs without

modification, only the stainless steel spherical ends have to be cut to the proper length. The Lorentz detuning compensation was achieved with the same maximum voltage for the piezo pulse (42V), and also the same characteristics for the time advance and rise time.

## 7 Conclusion

The active tuner developed at Saclay has been tested on a TTF type 9-cell cavity, using two different piezoelectric stacks actuators. The Lorentz force detuning could be successfully compensated at the maximum accelerating of 25 MV/m that this cavity could achieve. The piezo driving signals are of moderate amplitude (42 V). In principle the NOLIAC PZTs sustain a maximum voltage of 200 V. Doubling the accelerating field in the cavity would increase the Lorentz detuning by a factor of 4, which should still be in the range of the NOLIAC PZTs, if the dynamic behaviour of the mechanical system is linear. The LFD compensation at 35 MV/m should then be easily achieved.

## ACKNOWLEDGEMENTS

We acknowledge the support of the European Community-Research Infrastructure Activity under the FP6 "Structuring the European Research Area" programme (CARE, contract number RII3-CT-2003-506395). The experimental programme was carried out using the SUPRAtech GIS infrastructures with the financial support from Région d'Ile de France.

## References

- [1] M. Luong et al., "Minimizing RF power requirement and improving amplitude/phase control for high gradient superconducting cavities", Proc. of EPAC02, June 2002, Paris.
- [2] M. Liepe et al., "Dynamic Lorentz Force Compensation with a Fast Piezoelectric Tuner", Proc. of PAC01., June 2001, Chicago.
- [3] P. Bosland et al., "Third harmonic superconducting passive cavities in ELETTRA and SLS", Proc. of 11<sup>th</sup> SRF workshop, Sept 2003, Travemünde.
- [4] H. Sagnac et al., "CryHoLab, a horizontal cavity test facility: new results and development", Proc. of 11<sup>th</sup> SRF workshop, Sept 2003, Travemünde.
- [5] M. Luong et al., "Analysis of microphonic disturbances and simulation for feedback compensation", Proc. of EPAC06, June 2006, Edinburgh.
- [6] G. Martinet et al. "Low temperature properties of piezoelectric actuators used in SRF cavities cold tuning systems", Proc. of EPAC06, June 2006, Edinburgh.
- [7] G. Devanz et al., "Active compensation of Lorentz force detuning of a TTF 9-cell cavity in CRYHOLAB", Proc. of LINAC06, August 2006, Knoxville.