

EU contract number RII3CT-2003-506395

CARE Conf-06-012-HIPPI



STATUS OF THE 70 MeV, 70 mA CH PROTON-DTL FOR FAIR*

G. Clemente, H. Podlech, R. Tiede, U. Ratzinger, IAP, Universität Frankfurt/Main, Germany
L. Groening, GSI, Darmstadt, Germany
S.Minaev, ITEP, Moscow Russia

Abstract

The CH-type cavity shows promising features in the low and medium beta range: its high accelerator gradient and the high level of shunt impedance together with the compact transverse dimensions make this new cavity a good candidate for proton acceleration up to 100 MeV. That's why GSI has decided to base the new high current proton injector for the new FAIR facility on that structure: the operating frequency will be 352 MHz with an injection energy of 3 MeV. In order to improve the technical experience on this new kind of structure, IAP has built a model consisting of 8 equidistant gaps for a total cavity-length of 60 cm. Several design options with respect to welding, alignment, cooling and RF joints were studied and compared with each other. A new concept for the end-cells geometry will result in the desired flatness of the electric field along the cavity axis and, at the same time, allows an effective integration of internal quadrupole lenses. Finally, the electric quadrupole content of CH-structure gaps is listed in dependence on the geometry of the cell.

Contribution to the EPAC'06, Edinburgh, UK

Work supported by the European Community-Research Infrastructure Activity under the FP6 "Structuring the European Research Area" programme (CARE, contract number RII3-CT-2003-506395).

STATUS OF THE 70 MeV, 70 mA CH PROTON-DTL FOR FAIR*

G. Clemente[#], H. Podlech, R. Tiede, U. Ratzinger, IAP, Universität Frankfurt/Main, Germany
 L. Groening, GSI, Darmstadt, Germany
 S.Minaev, ITEP, Moscow Russia

Abstract

The CH-type cavity shows promising features in the low and medium beta range: its high accelerator gradient and the high level of shunt impedance together with the compact transverse dimensions make this new cavity a good candidate for proton acceleration up to 100 MeV. That's why GSI has decided to base the new high current proton injector for the new FAIR facility on that structure: the operating frequency will be 352 MHz with an injection energy of 3 MeV. In order to improve the technical experience on this new kind of structure, IAP has built a model consisting of 8 equidistant gaps for a total cavity-length of 60 cm. Several design options with respect to welding, alignment, cooling and RF joints were studied and compared with each other. A new concept for the end-cells geometry will result in the desired flatness of the electric field along the cavity axis and, at the same time, allows an effective integration of internal quadrupole lenses. Finally, the electric quadrupole content of CH-structure gaps is listed in dependence on the geometry of the cell.

INTRODUCTION

The new FAIR facility, under development at GSI in Germany, will provide new features for experiments in the field of atomic, nuclear and particle physics. One of the main feature of FAIR will be the availability of intense beams of cooled antiprotons. In order to produce such a beam of antiprotons the intensity and the energy of the primary proton beam has to be increased beyond the possibility of the existing UNILAC [1]. For this reason a new proton injector has to be built: it has to provide a 70 mA beam at a final energy of 70 MeV. With a chosen standard frequency of 352 MHz, an attractive solution is a CH-DTL that, in combination with KONUS beam dynamics, could achieve a shunt impedance in the range of 100-45 MOhm/m along the whole velocity profile [2].

To prove those promising calculations as well as to demonstrate the feasibility in terms of construction and copper plating an 8 cells CH cavity has been built

THE CH TEST CAVITY

A test cavity made of 8 gaps (cell length $\beta\lambda/2$ of 45 mm) for a total length of 60 cm was built. An existing massive stainless steel cylinder of 332 mm inner diameter was used. The aim of this model was to test all the fabrication steps and to find out technical solutions in order to show the feasibility of cross-bar cavities with respect to mechanical construction and copper plating.

Design and construction

Compared to an earlier proposed design [2], the geometry of the cavity has been completely modified in order to reduce the potential misalignment of the drift tubes and to improve the electrical field distribution.

The original design presented an internal girder that would have been used also as a cooling channel: unfortunately this solution would have created some technical difficulties during the welding process in terms of misalignment of the drift tubes as well as in terms of deformation of the outer cylinder. For this reason, completely new solutions have been adopted: conical stem ends are welded from inside to the cavity wall and all the stems are directly water cooled. Finally, the outer cylinder is cooled down by four independent water jackets. Fig.1 shows a view of the cavity with the water cooling connections. The cavity was fabricated in the IAP workshop in Frankfurt and it was released end of February '06.

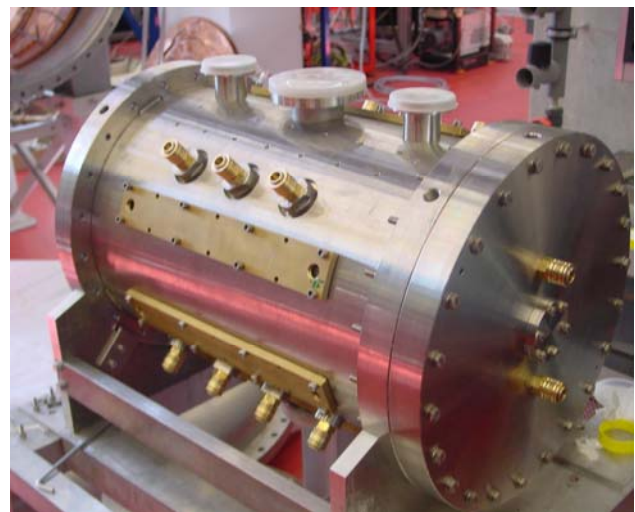

Fig.1: The CH test model. Note the single water cooling connections of each stem together with the cooling jackets on the outer wall

After successful He leakage tests, the mechanical precision was checked. Indeed all drift tubes centre positions were within the tolerance of ± 0.2 mm while each drift tube received an elliptical deformation from the welding process: as a consequence, it was decided to choose a heavier design for the drift tubes. They will be now completely made in stainless steel: press-fitted half drift tubes from massive copper, as suggested earlier [3, 4] are no more favourite for the design of GSI Proton Injector. Moreover, the mechanical stress resulting from

*Work supported by GSI, BMBF (0671341) and EU (CARE Contract No. RII-CT-2003-506395)

[#]clemente@iap.uni-frankfurt.de

stems welding into the cavity walls will be further reduced by a modified welding technique.

The first measurements of the RF frequency before copper plating, 340.03 MHz, showed a good agreement with the Microwave Studio[®] value of 338.7 MHz.

After this preliminary RF measurements the cavity was transferred to GSI where the copper plating was performed at the end of May '06. The success of copper plating shows definitely the mechanical feasibility of the CH-type cavity. A detail of the copper plated structure is shown in Fig.2

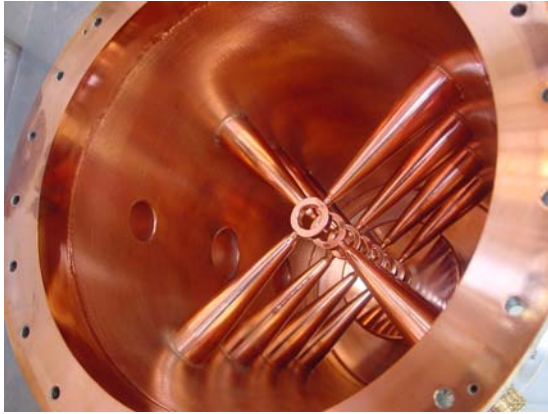

Fig.2: A detail of the copper-plated CH. The big end cell will host the internal quadrupole lens and, at the same time, will provide the needed flatness of the electric field along the cavity axis.

After copper plating the measured Q_0 value was around 9400, while Microwave Studio gave 13000 in the case of ideal copper

Concerning the distribution of the accelerating field, the new design of the end half drift tubes [3] will provide the desired flatness of the electric field along the cavity axis ($H_{21(0)}$ mode) and, at the same time, allows an effective integration of internal quadrupole lenses. By this way also longitudinal beam dynamics, which depends on short intertank sections, profits a lot. The main parameters of this first room temperature CH cavity are summarised in Tab.1

Tab.1: parameters of the CH-DTL Test Cavity

Number of cells	8
$\beta\lambda/2$	45 mm
Total inner length	60 cm
Inner Radius	166 mm
Drift tube aperture \varnothing	22 mm
Frequency	340.2 (338.7 calculated)
Unloaded Q-Value	~9400 (~13000 calculated)

QUADRUPOLE FIELD COMPONENTS

Due to its particular symmetry the CH structure contains no dipole components of the electric field in the gap but only quadrupole ones that could influence the beam behaviour; for this reason those components were

investigated in dependence of the cell geometry. Two different shapes were studied (see Fig.3), one of them dedicated to the low energy entrance, with a small neck at the stem end, and the others of simple conical shape. Three different sets of sizes are chosen dependently on the energy range in order to optimize the shunt impedance. In this paper we present only the main results while detailed calculations can be found in [5].

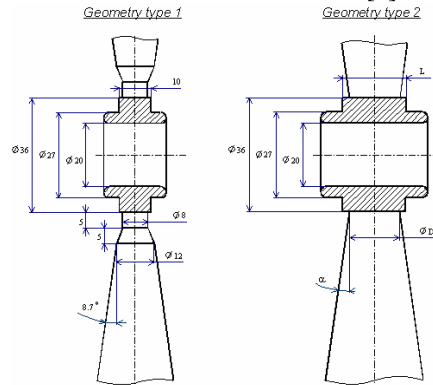

Fig.3: The different drift tube geometries proposed for the GSI CH- DTL

A 3D solver was developed in order to evaluate those quadrupole components inside a CH-type gap: aiming to include those components into the beam dynamics code LORASR, that requires the effective voltages applied to the accelerating gaps as an input parameter, gradients have been specified for the different geometries at the gap voltage of 1 V and related to the transit-time factor:

Tab.2: The main geometrical parameters of the stems in dependence on the particles energy.

	Energy Range	Ring length l	Cone Angle α	Min. Stem Diameter
Stem 1	3-5 MeV	10 mm	8.6 °	8 mm
Stem 2	5 - 10 MeV	14 mm	9.6 °	12 mm
Stem 3	10 - 40 MeV	20 mm	9.9 °	16 mm
Stem 4	40 -70 MeV	30 mm	9.8 °	20 mm

$$G = \frac{G_1}{TTF} \quad (V/m^2),$$

where G_1 is the electric gradient of the effective quadrupole content for an applied voltage amplitude of 1 V.

Using this definition, the gain of the transverse particle velocity in the accelerating cell due to quadrupole component can be found as

$$\Delta\beta_x = \frac{e \cdot \lambda}{4m c} \cdot G \cdot V_{eff} \cdot x_c \cdot \cos(\phi_c),$$

where x_c is the coordinate of the particle at the gap center, ϕ_c is the phase of the particle at the gap center (in cosine count) and V_{eff} is the effective gap voltage.

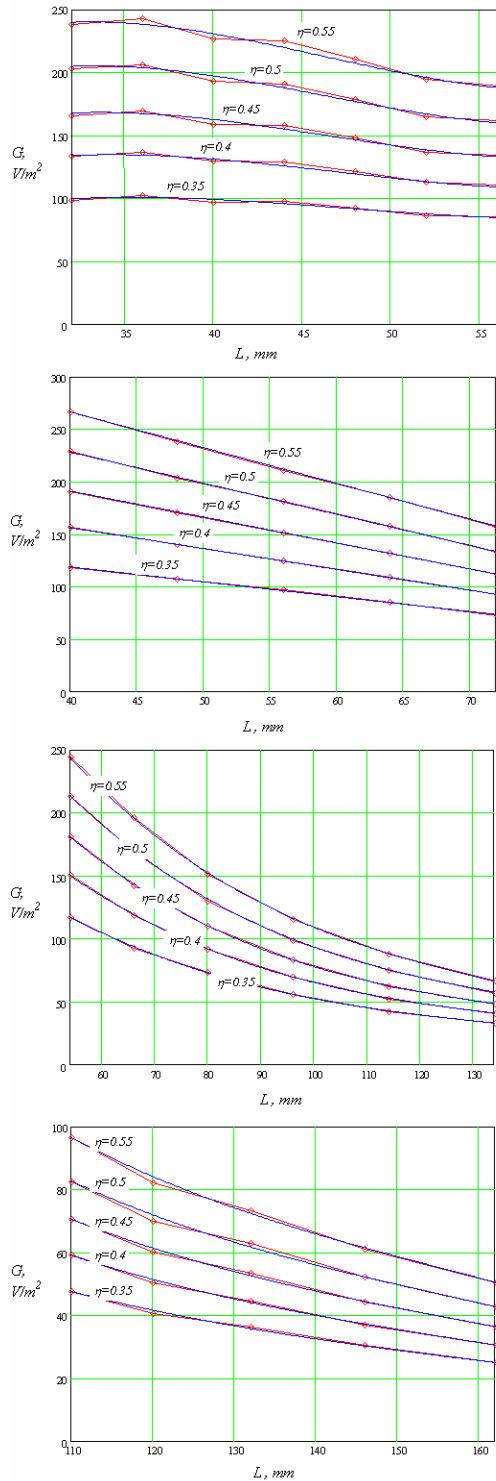

Fig.4: Quadrupole components of a CH-type gap for the different geometries listed in Tab.2 and for different values of the gap-to-cell ratio $\eta = g/L$. G is normalized to a gap voltage of 1 V.

Calculations have been done in some range of cell length $L = \beta\lambda/2$ and gap-to-cell ratio $\eta = g/L$ for each stem geometry; fig.4 shows the results for the different geometries according to Table 2.

At an energy of 7.5 MeV (middle of tank2) and at a gap-to-cell ratio of 0.5, one can find an effective electric gradient for 1 V gap voltage of $G = 188 \text{ V/m}^2$. If an effective voltage of 0.5 MV is applied, the transverse phase advance can be estimated as $\mu_x = 0.4$ deg per focusing period which is as long as $\beta\lambda$. Even if this value is quite small, the cumulative effect of those quadrupole components could reach several degrees along one cavity and, finally, has to be taken into account for final beam dynamics simulations.

CONCLUSIONS AND FUTURE PLANS

The feasibility of the CH cavity with respect to mechanical construction, tolerances and copper plating has been demonstrated by the realisation of a first test cavity. RF properties as well as the cooling system will now be tested in IAP with a 2 kW, cw amplifier. The experience gained with such a model will be applied in the production of full scale prototypes of the third and fourth module of the GSI Proton Injector. These cavities will cover the energy range from 10 to 20 MeV and they will be available for tests in 2008.

Concerning beam dynamics, the quadrupole components of the CH-type gaps have been investigated and they will be introduced into our LORASR code.

ACKNOWLEDGMENTS

We acknowledge the support of the European Community-Infrastructure Activity (CARE Contract No. RII3-CT-2003-506395).

All the authors would like to thank the IAP workshop for the high motivation during the realisation of the first room temperature CH cavity.

REFERENCES

- [1] U. Ratzinger et Al "The 70 MeV p-Injector Design for Fair", Proceedings of the ICFA-HB04, Bensheim, Germany, September 18-22 2004
- [2] H.Li et Al "Design of the R.T. CH-Cavity and Perspective for the GSI Proton Injector", EPAC'04, Lucerne, July 2004, p. 249,
- [3] G.Clemente et Al "Development of Normal Conducting CH-DTL", PAC '05, Knoxville, TN, USA May 16-20 2005
- [4] G.Clemente et Al "Geometrical Optimisation of the 70 MeV, 70mA CH-Proton Injector for FAIR", GSI Annual Report 2004
- [5] S. Minaev, "A Simulation of Quadrupole Component of Electric Field in the 70 MeV GSI Proton Linac Based on the CH Structure", IAP Internal Note Nr. IAP - DYNA 220605, 2005