

November 29, 2007

Letter of Intent to the CERN-SPSC

A new path to measure antimatter free fall

P. Pérez, L. Liskay, B. Mansoulié, J.M.Rey
DAPNIA, CEA-Saclay, France

A. Mohri, Y. Yamazaki
Atomic Physics Laboratory, RIKEN, Wako 351-01, Japan

N. Kuroda, H.A. Torii,
Institute of Physics, University of Tokyo, Komaba, 153-8902 Tokyo, Japan

Executive Summary

We propose an experiment to measure the free fall acceleration of neutral antihydrogen atoms. The originality of this path is to first produce the \bar{H}^+ ion. This ion can be cooled down to μK temperatures (i.e. m/s velocities) according to Walz and Hänsch [1]. The excess positron can then be laser detached in order to recover the neutral \bar{H} atom. This process can be set up to minimize momentum transfer in the vertical direction. The temperature achieved in cooling of the \bar{H}^+ ion gives the main systematic error. This ion is produced through the charge exchange process $\bar{p} + \text{Ps} \rightarrow \bar{H} + e^-$, followed by $\bar{H} + \text{Ps} \rightarrow \bar{H}^+ + e^-$. The matter counterpart of the first process has been measured [2] in agreement with calculations with cross sections of order 10^{-15} cm^2 [3]. The calculated cross section for the second process is 10^{-16} cm^2 [4]. Thus if 10^7 antiprotons interact with a density of 10^{12} cm^{-3} Ps atoms, 1 \bar{H}^+ ion is produced, together with 10^4 \bar{H} atoms. Collecting 1000 events should provide a 2% measurement error on g .

The antiprotons are provided by the setup already in use by the ASACUSA collaboration. The so-called MUSASHI trap is able to store 10^7 antiprotons from 12 AD shots. Development to improve the extraction into a bunch of less than 1 mm diameter and 10 ns length at 6 KeV will be needed.

The positronium target should reach a density greater than 10^{12} cm^{-3} during the passage of the antiproton bunch. Such a target is obtained by dumping positrons onto the internal surface of a $1 \text{ mm}^2 \times 1 \text{ cm}$ hollow cylinder made of a material that converts positrons into Ps in the fundamental state. For instance a cylinder internally coated with a nanoporous SiO_2 layer also reflects the Ps produced in order to keep the density of Ps inside this cavity. We have already obtained and measured layers that convert positrons into ortho-positronium and eject them into vacuum with more than 30% efficiency and an average kinetic energy of 80 meV [5].

In order to reach the required Ps density, 10^{11} positrons must be collected at the same rate as 10^7 antiprotons are collected. An intense source of positrons is thus necessary. We are building in Saclay a device based on a small 6 MeV electron linac to produce positrons via pair production on a tungsten target [6]. This device should provide 10^8 slow e^+ /s, i.e. a factor 300 faster than the strongest activity Na_{22} based setups, and could be easily duplicated or improved at CERN. A Penning-Malmberg trap can be adapted to store and extract 10^{10} to 10^{11} positrons in ultra high vacuum conditions.

As this proposal relies on the estimates of the \bar{H}^+ production cross-section, a first milestone is to measure the $p + \text{Ps} \rightarrow \text{H} + e^+$, followed by $\text{H} + \text{Ps} \rightarrow \text{H}^+ + e^+$. This does not use antiproton beam time, but work in parallel of this measurement could prepare for antiproton running conditions. If results are positive, the measurement can be repeated with antiprotons. Trapping and cooling of the \bar{H}^+ ion is the further milestone to be followed by the gravity measurement.

A planning covering 5 years seems feasible to reach the gravity measurement.

1 Motivation

There is no measurement of the free fall of antimatter in the gravitational field of the Earth. More generally there is no direct test of the Equivalence Principle with antimatter. Extended $N=2$ to 8 supergravity models may contain gravivector components inducing repulsive gravity [7]. Such models are constrained to non-astrophysical ranges [8]. The experiment we propose is a direct measurement.

2 Scheme

We follow the scheme proposed by Walz and Hänsch [1], which uses \bar{H}^+ ions. These ions are cooled by interactions with positively charged ions to μK temperatures, and then subjected to an appropriate laser beam to photo detach the extra positron, inducing a minimal vertical kick to the remaining neutral atom. With 1000 (resp. 500 k) \bar{H} atoms cooled at 20 μK , this would give a 2 % (resp. 0.1%) precision on g .

In order to produce these \bar{H}^+ ions, we propose to use the set of two reactions: $\bar{p} + \text{Ps} \rightarrow \bar{H} + e^-$ [2], followed by $\bar{H} + \text{Ps} \rightarrow \bar{H}^+ + e^-$, from interactions of antiprotons and \bar{H} with the same positronium target [6,9].

The \bar{H} production cross-section is $\sigma_{\bar{H}} \sim 10^{-15} \text{ cm}^2$, for incident \bar{p} between 5 and 15 keV on ground state Ps. The only measurement on the matter counterpart using protons [2] agrees within errors with calculations [3], which are mainly statistical due to the low density of positronium that was available (figure 1).

In order to estimate the \bar{H}^+ production, we use the calculation available for the production of H^- from $H (n_H=1) + \text{Ps} (n_{Ps}=1)$ [4], which gives a cross section of 10^{-16} cm^2 (*), for $\sim 6 \text{ keV}$ \bar{H} incident on ground state Ps (figure 2).

3 Antiproton beam

The \bar{p} beam is formed by extracting the antiprotons stored in the MUSASHI trap, which is a part of the ASACUSA collaboration apparatus. Routinely, over 10^6 \bar{p} are stored, radially compressed and extracted. Increasing this number to 10^7 is easily attainable by accumulating AD shots [10].

Development will be needed to compress the antiprotons in a 10 ns bunch and accelerate it at an energy of 6 keV with less than 1 mm transverse beam size.

4 Ps target

The Ps target is formed by the interaction of a positron beam onto a porous SiO_2 film. The conversion into Ps depends on the nature of the converter material. We measured over 35% conversion efficiency into ground state oPs for implantation energy of 3 keV at room temperature, using mesoporous SiO_2 layers [5]. Due to the negative workfunction of this material the produced Ps is expelled into vacuum at a rate

(*) Exciting Ps to low levels might be beneficial, not only for the \bar{H}^* production, but also for \bar{H}^+ as its binding energy of 0.75 eV is almost degenerate with the $n_{Ps}=3$ level of Ps [13].

depending on the structure of the nanopores. We measured that 95% of the produced Ps is ejected towards vacuum with an average kinetic energy of 80 meV. We are studying the possibility to reach thermalisation, i.e. 25 meV at room temperature. If successful, lowering the temperature of the converter could further decrease the Ps energy. The layers already tested are sufficient for the present proposal and are easily reproducible.

We are now preparing a hollow cylinder with its internal surface covered with the same nanoporous SiO₂ material. When positrons are implanted inside this hollow cylinder, it is expected that the oPs atoms, which are expelled into the cylinder hole and have not yet decayed, be reflected back in the hole. We are preparing an experiment to measure the Ps density produced inside such a cylinder. The reflectivity is expected to be 100%.

With $3 \cdot 10^{10}$ e⁺ dumped into such a cylinder of 1 mm diameter and 1 cm length, a density ρ_{Ps} of order 10^{12} cm⁻³ is reached. Taking into account the Ps lifetime reduces the number of Ps atoms present in this volume during the dump of the antiproton bunch.

5 Positron production and trapping

The stacking of 10^{10} e⁺ in an accumulation trap would take 100 s if one would use as input the positron flux from a linac based device such as the one studied in our laboratory [6,9]. This setup comprises a 6 MeV linac with a current equivalent to 0.2 mA DC and a tungsten target. If a simple tungsten foil moderator would be adapted to this setup with an efficiency of a $5 \cdot 10^{-4}$, a rate of 10^8 slow e⁺/s should be reached. First results should be obtained in 2008. We also foresee to adapt a set of coils to guide the emitted positrons and eject the electrons in order to replace the tungsten moderator with a solid neon moderator. With such a setup efficiencies 10 times higher are expected. This must be located inside a 1m thick concrete shielding. With a 100 mCurie Na²² source, the filling time would be about 100 times longer. Using a linac with increased energy or current would easily increase the yield. This linac based source of positrons must be coupled with an accumulation trap to store up to 10^{11} e⁺.

The well depth of the present RIKEN MRT trap allows storing 10^{10} positrons. We have performed tests to extract these e⁺ in 75 ns. The beam diameter inside the trap is as low as 0.7 mm and reaches 100µm when rotating wall compression is applied. The extracted beam has a diameter of 1cm at 1 m from the trap centre, and 1 mm when rotating wall compression is applied. It is also foreseeable to improve the isolation in such a trap in order to obtain a 10 kV deep potential well, and thus accumulate 10^{11} positrons. A buncher could also be added at the exit of the trap in order to further compress the bunch in time [11].

6 \bar{H} and \bar{H}^+ production rates

The \bar{H} rate in the ground state is $N_{\bar{H}} = N_{\bar{p}} \times \rho_{Ps} \times L \times \sigma_{\bar{H}}$, where $N_{\bar{p}}$ is the number of antiprotons, ρ_{Ps} is the density of the Ps target, L is the length of this target, and $\sigma_{\bar{H}}$ is the cross section. In turn, $N_{\bar{H}^+} = N_{\bar{H}} \times \rho_{Ps} \times L \times \sigma_{\bar{H}^+}$, where $\sigma_{\bar{H}^+}$ is the cross section

to produce the ion. For 6 keV incident \bar{p} energy, we take $\sigma_{\bar{H}} = 10^{-15} \text{ cm}^2$, and $\sigma_{\bar{H}^+} = 10^{-16} \text{ cm}^2$. The corresponding rates are given in table 1 for $L = 1 \text{ cm}$.

$N(\bar{p})$	$\rho_{\text{Ps}} (\text{cm}^{-3})$	$N(\bar{H})$	$N(\bar{H}^+)$
10^7	10^{12}	10^4	1
10^7	10^{13}	10^5	10

Table 1: *Yields of atoms and ions depending on Ps density.*

7 Overall scheme

The AEGIS proposal [12] has the same goal concerning the effect of gravity on antimatter and also uses ortho-positronium produced by similar methods to ours [5]. The major point of our proposal is the use of the \bar{H}^+ ion, which can be easily manipulated and in particular slowed down. Hence the gravity experiment is performed with \bar{H} at rest. Table 2 shows the main differences with the AEGIS proposal. The overall scheme is depicted in figure 3.

This LOI	AEGIS
\bar{H}^+ cooled $\rightarrow \bar{H}$ (1 m/s, n=1)	\bar{H}^* (500 m/s, n=25) \rightarrow Moiré deflectometer
Accumulate 10^{10} to $10^{11} e^+$	Accumulate $10^8 e^+$
Accumulate $10^7 \bar{p}$	Accumulate $10^6 \bar{p}$ at 100 mK
3 \bar{H} per hour directly usable for free fall	10^4 per hour sent to deflectometer, $\epsilon \sim 1\%$
$4 \cdot 10^3 \bar{H}$ (1200 h) $\rightarrow \Delta g/g = 1\%$ (syst)	1000 h $\rightarrow \Delta g/g = 1\%$ (stat) + ? (syst)

Table 2 : Differences w.r.t. AEGIS.

8 Milestones

- A- Produce a Ps target of high density.
- B- Measure the cross sections :
 - $p + \text{Ps} \rightarrow \text{H} + e^+$, followed by $\text{H} + \text{Ps} \rightarrow \text{H}^- + e^+$,
 - using a setup as close as possible to the final one to be used with antiprotons,
 - and
 - $\bar{p} + \text{Ps} \rightarrow \bar{\text{H}} + e^-$, followed by $\bar{\text{H}} + \text{Ps} \rightarrow \bar{\text{H}}^+ + e^-$,
- C- Cool $\bar{\text{H}}^+$, using a trap filled with Be^+ .
- D- Detach excess positron to recover a neutral atom.
- E- Free fall measurement

Step A can be performed with increasing numbers of positrons:

- 0) Ps reflection can be measured at CERN's slow e^+ beam at low Ps density, i.e. $10^4 e^+/s$.
- 1) Extract and focus $10^{10} e^-$ from the existing RIKEN MRT trap onto a 1 mm diameter target.
- 2) Perform the same experiment replacing electrons by positrons, and measure and optimize the Ps density obtained. At RIKEN there is a 50 mCurie Na22 source

equipped with a Neon moderator. Typically $10^8 e^+$ can be stored in 10 minutes. Measurements with increasing numbers of e^+ can be performed.

3) Repeat this using the final e^+ trap (RIKEN's trap to be built at CERN in 2008 or Saclay's copy to be adapted to the linac in 2009).

Steps B to E would take place at CERN on the existing ASACUSA line. The method could be exercised to a large extent with matter (protons) during antiproton beam downtime.

References

- [1] *A Proposal to Measure Antimatter Gravity Using Ultracold Antihydrogen Atoms*, J. Walz and T. Hänsch, *General Relativity and Gravitation* **36** (2004) 561.
- [2] *On antihydrogen formation in collisions of antiprotons with positronium*, J.W. Humberston, M. Charlton, F.M. Jacobsen and B.I. Deutch, *J. Phys.* **B 20** (1987) L25-29 ; *Hydrogen Formation by Proton Impact on Positronium*, J. P. Merrison et al., *Phys. Rev. Lett.* **78**, 2728 (1997); J.P. Merrison et al., *Hyperfine Interact.* **109** (1997) 313321.
- [3] *Antihydrogen-formation cross sections in antiproton-positronium collisions with a time-dependent coupled-channel method*, M. Yamanaka, Y. Kino, *Phys. Rev. A* **65** (2002) 062709 and references therein;
A. Igarashi, N. Toshima, T. Shirai, *J. Phys. B* **27** (1994) L497; J. Mitroy, G. Ryzhikh, *J. Phys. B* **30** (1997) L371; K. Ratnavelu, J. Mitroy, *J. Phys. B* **28** (1995) 287.
- [4] *Positron and positronium scattering*, H.R.J. Walters and C. Starett, *Phys. Stat. Sol. C*, 1-8 (2007).
- [5] *Orthopositronium annihilation and emission in mesostructured thin silica and silicalite-I films*, L. Liskay et al., contribution to the SLOPOS 11 workshop, preprint DAPNIA-07-125.
- [6] *Intense source of slow positrons*, P. Pérez and A. Rosowsky, *Nuc. Instr. Meth. A* **532** (2004) 523; *A Scheme to Produce a Dense Positronium Plasma for an Antihydrogen Experiment*, P. Perez et al., contribution to the SLOPOS 11 workshop, preprint DAPNIA-07-99 ;
http://www-dapnia.cea.fr/Phocea/Vie_labos/Ast/ast_technique.pho?id_ast=784
- [7] *Antigravity: a crazy idea?* J. Scherk, *Phys. Lett. B* **88** (1979) 265.
- [8] *Effects of the gravivector and graviscalar fields in $N = 2, 8$ supergravity*, S. Bellucci and V. Faraboni, *Phys. Lett. B* **377** (1996) 55.
- [9] *A new path toward gravity experiments with antihydrogen*, P. Pérez and A. Rosowsky, *Nucl. Inst. Meth. A* **545** (2005) 20-30.
- [10] N. Kuroda (*private communication*).

[11] *Accumulator for the production of intense positron pulses*, D.B. Cassidy et al., Rev. Sci. Instrum. **77**, 073106 (2006).

[12] G. Dobrychev *et al.* CERN-SPSC-2007-017, CERN-SPSC-P-334, June 2007.

[13] M. Charlton (*private communication*).

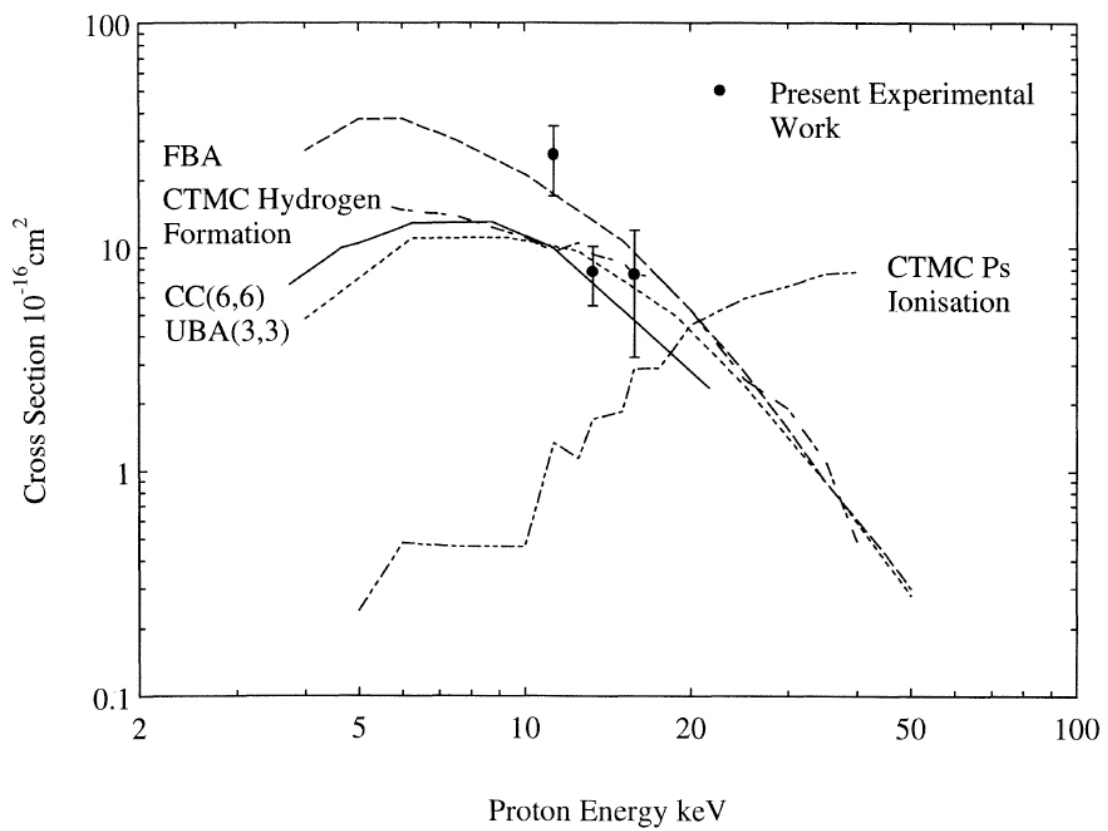

Figure 1 : *Hydrogen production cross section as a function of the proton kinetic energy in the laboratory frame (Ps at rest) [2].*

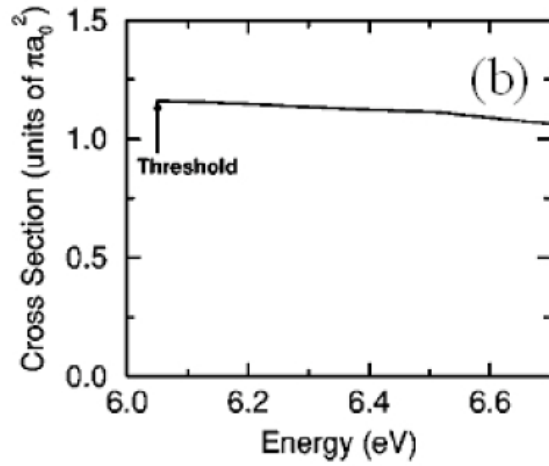

Figure 2 : H production cross section from hydrogen interaction with Ps as a function of the incident Ps energy on H at rest [4]. In this frame, 6.1 eV corresponds to H of 5.6 keV kinetic energy onto Ps at rest. ($\pi a_0^2 = 0.88 \cdot 10^{-16} \text{ cm}^{-2}$).

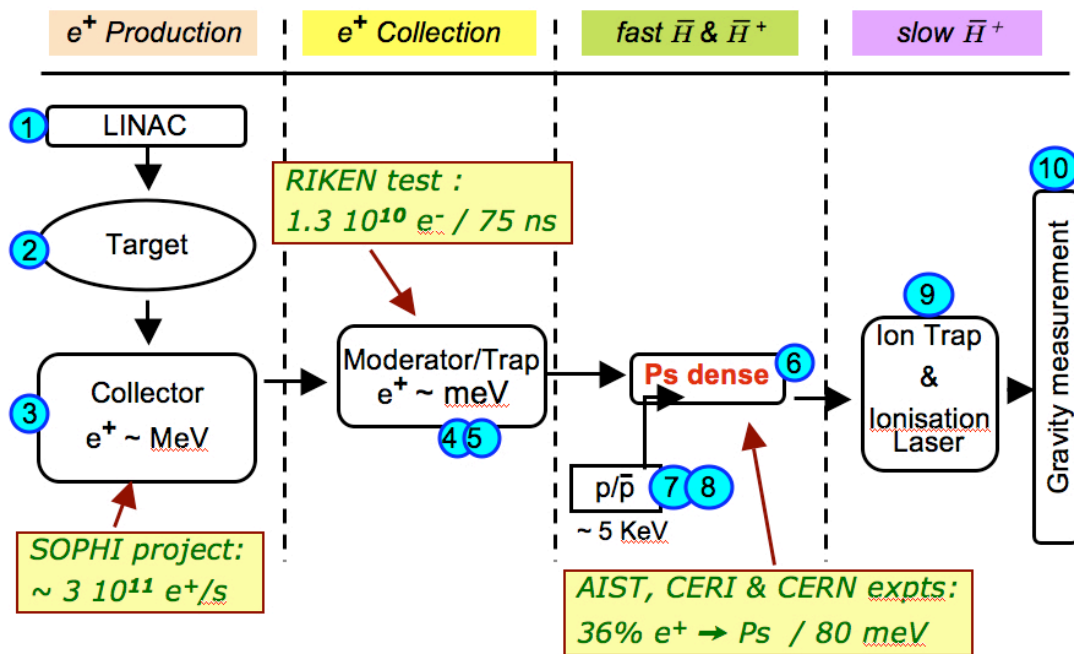

Figure 3 : Overall scheme.