



PUBLISHED BY INSTITUTE OF PHYSICS PUBLISHING AND SISSA

RECEIVED: December 15, 2007

ACCEPTED: February 13, 2008

PUBLISHED: February 29, 2008

Developments and the preliminary tests of resistive GEMs manufactured by a screen printing technology

G. Agócs,^{ab} B. Clark,^c P. Martinego,^d R. Oliveira,^d V. Peskov,^{de*} P. Pietropaolo^{df} and P. Picchi^{dg}

^a Eotvos University, Budapest, Hungary

^b KFKI RMKI Research Institute for Particle and Nuclear Physics, Budapest, Hungary

^c North Carolina State University, U.S.A.

^d CERN, Geneva, Switzerland

^e Ecole Superior des Mines in St. Etienne, France

^f INFN Padova, Italy

^g INFN Frascati, Italy

E-mail: Vladimir.peskovcern.ch

ABSTRACT: We report promising initial results obtained with new resistive-electrode GEM (RETGEM) detectors manufactured, for the first time, using screen printing technology. These new detectors allow one to reach gas gains nearly as high as those achieved using ordinary GEM-like detectors with metallic electrodes. However, due to the high resistivity of its electrodes the RETGEM, in contrast to traditional hole-type detectors, have the advantage of being fully spark protected.

A primary benefit of these new RETGEMs is the availability of screen printing technology to many research laboratories; this accessibility encourages the possibility to manufacture these GEM-like detectors with the electrode resistivity easily optimized for particular experimental or practical applications.

KEYWORDS: Photon detectors for UV, visible and IR photons (gas) (gas-photocathodes, solid-photocathodes); Gaseous detectors; Electron multipliers (gas); Photon detectors for UV, visible and IR photons (gas).

* Corresponding author.

Contents

1. Introduction	1
2. Materials and methods	2
2.1 The RETGEM manufacturing by a screen printing technology	2
2.2 The principle of operation	2
2.3 Experimental setup	3
3. Results	4
3.1 Tests in Ne	4
3.2 Tests in Ar and Ar+CO ₂	6
3.3 Tests of photosensitive RETGEMs	8
4. Conclusions	9

1. Introduction

In the last decade, a great interest arose to various hole-type avalanche gaseous detectors: array of capillaries [1], capillary plates [2], gas electron multiplier (GEM) [3], which offer considerable promise in many applications, such as constituting the basic element for gas photomultipliers [4],[5] in TPCs and as tracking devices [6].

For the several years our focus has been centered on the development of a more robust version of the hole-type detectors: Thick GEM (TGEM) [7],[8] and TGEM with oxide coatings [9]. The developments of the TGEM were later successfully continued by Breskin group [10]. The greatest success, however, was noticed when the electrodes of TGEM were manufactured from resistive materials. In the first attempt, a thick layer of graphite paint was used [11]; in the latest version we successfully tested resistive Kapton [12]. Both types of resistive detectors could operate at gains as high as TGEM's while offering the advantage of being fully spark-protected.

Unfortunately, it turned out that it is not easy to obtain resistive Kapton from DuPont, which is the sole producer of Kapton. However, there is nothing unique concerning the choice of graphite coating or Kapton, and certainly many other materials could be used to achieve the same spark-protective effect; this notion encouraged the development and testing of the first prototypes of RETGEMs made manufactured using screen printing technology.

Screen printing is widely used in microelectronics to produce patterns of different shape and resistivity. Therefore, RETGEM technology produced with screen printing techniques offers a convenient and widely available alternative to RETGEMs made of Kapton. This report serves to summarize the immediate results obtained in testing these new RETGEMs.

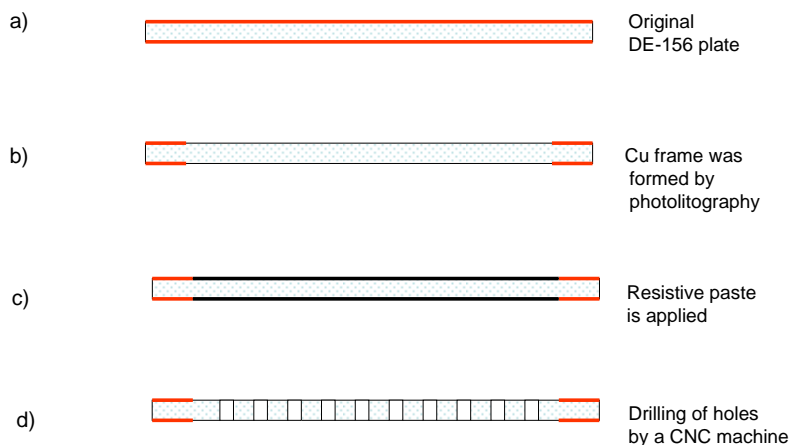

Figure 1. Consequent steps in manufacturing RETGEM using screen printing technology: a) An original G-10 plate b) Cu frame was manufactured c) Resistive paste was applied d) Cured in air at 200° C e) Hole matrix was drilled.

2. Materials and methods

2.1 The RETGEM manufacturing by a screen printing technology

A plate of DE-156, an Isola product often referred to as “G-10,” coated on both sides with 17 μ m of copper was used as the base material (figure 1a).

The detectors were manufactured in the following consequent steps:

1. A photolithographic method was implemented to remove the excess copper from the top and bottom center regions of the DE-156. The result was the creation of a copper border (see figure 2b).
2. A resistive paste (Encre MINICO used for transistors in printed circuits) is applied to the top and the bottom surfaces using screen printing technology (figure 1c). The paste is cured in air at 200° C for one hour.
3. A uniform matrix of consistently sized holes were drilled (using a CNC machine) in the region enclosed by the copper border (see figure 1d).

In the work referred to in this paper, we tested two types of RETGEMs. Type-1 had the following geometrical and resistive characteristics: thickness was 1mm, active area was 30 x 30 mm², hole diameter was 0.5 mm, pitch was 0.8 mm, resistive layer thickness was 15 μ m or 30 μ m, the surface resistivity was 1M Ω /□ or 0.5M Ω /□, respectively. Type-2 had the same active area, but it was 0.5 mm thick, hole diameter was 0.3 mm, pitch was 0.7 mm, resistive layer thickness was 30 μ m and the surface resistivity was 0.5M Ω /□.

The photo of one of our detectors is presented in figure 2. Investigations by a microscope reveal a high quality of holes and borders around them (see figure 3a and b).

2.2 The principle of operation

The principle of operation for this detector is the following: when a high voltage (HV) is applied to the Cu frames the resistive electrodes, due to their non-infinite resistivity, are charged up to a potential equal to that of the respective Cu frames and begin to act as equipotential layers (assuming the electrostatic case). The resulting electric field is similar to the field produced in a TGEM, which implements metallic electrodes (see figure 4). One can expect that at low counting rates the detector will operate as a conventional TGEM; whereas, at high counting rates and in the case of discharges the detector’s behavior will be similar to that of a resistive plate chamber.

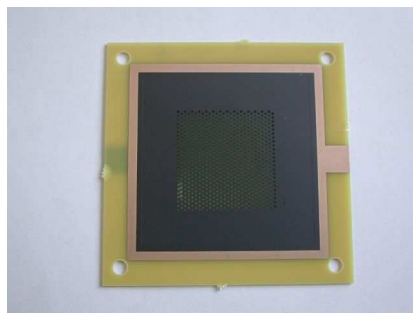

Figure 2. A photo of the RETGEM produced using screen printing technology.

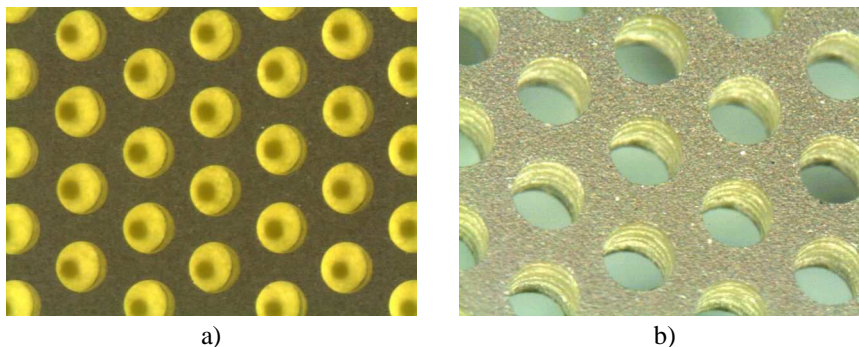

Figure 3. Photo of holes at various magnifications: a) medium magnification, b) higher magnification.

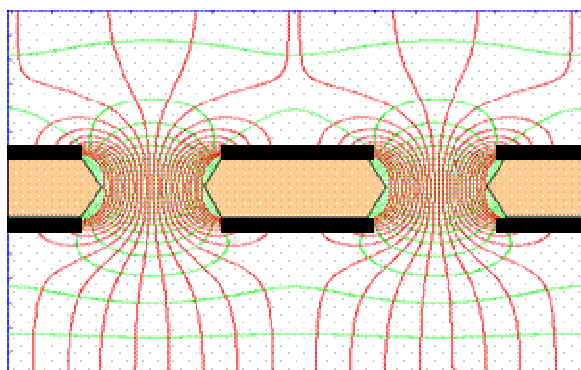

Figure 4. Expected field line formation in the RETGEM.

2.3 Experimental setup

Our experimental setup consisted of a UV lamp, a monochromator, a test chamber housing a RETGEM, or two RETGEMs operating in cascade, and a gas system, which allowed for the flushing of various gases through the chamber (see figure 5). In the case of the double RETGEM setup, a resistive chain was implemented as shown schematically in figure 5.

To insure a fair comparison of these new RETGEMs with Kapton RETGEMs, tests were performed in the same gases as in the case of the Kapton RETGEM; these gases included Ne, Ar, and mixtures of Ar with CO_2 , which were all maintained at an approximate pressure of 1 atm.

Ionization of the gas was produced either by an ^{241}Am alpha emitting source or by an ^{55}Fe x-ray emitting source. The signals from the detector were recorded by a charge sensitive amplifier, Ortec 142PC or CANBERRA, and then, if necessary, additionally amplified by an Ortec research amplifier. The absolute sensitivity of the charge sensitive amplifiers was calibrated by a charge injection method (see [9]).

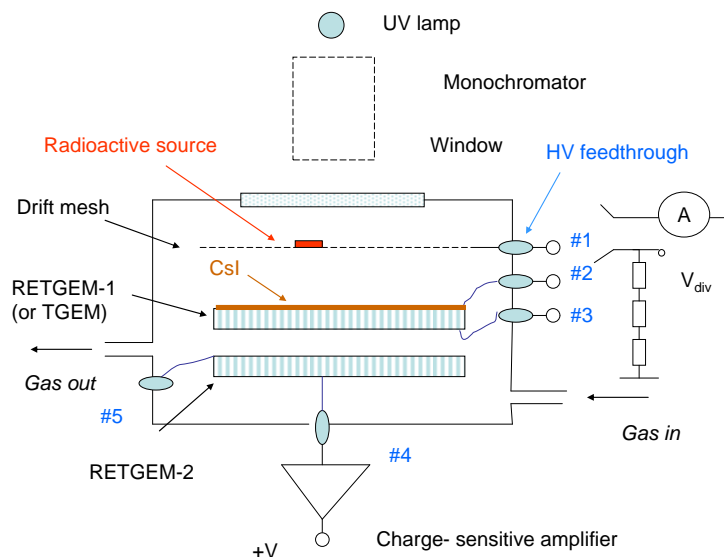

Figure 5. A schematic drawing of the experimental setup.

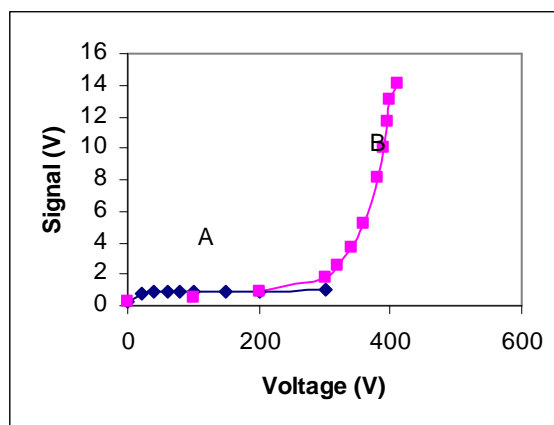

Figure 6. Results of measurements with alpha particles in Ne. In these measurements RETGEM type-1 was used with resistivity $1 \text{ M}\Omega/\square$.

Kapton RETGEM coated with a CsI photosensitive layer was previously discovered to offer high quantum efficiency (QE) for UV light [12]. In order to verify the validity of the same effect in the case of screen printed RETGEMs, some of the RETGEMs were coated with a $0.35 \mu\text{m}$ thick CsI layer using a vacuum evaporation technique. After the evaporation was complete, the RETGEM was extracted from the evaporation system and installed inside the gas chamber. When studying these photosensitive RETGEMs we typically implemented a monochromator combined with a Hg lamp (see figure 5). The measurements were performed either in pulse counting mode using charge sensitive amplifiers or in current mode, using a picoammeter, Kethley 487.

3. Results

3.1 Tests in Ne

Figure 6 shows some results of measurements with the alpha source in Ne.

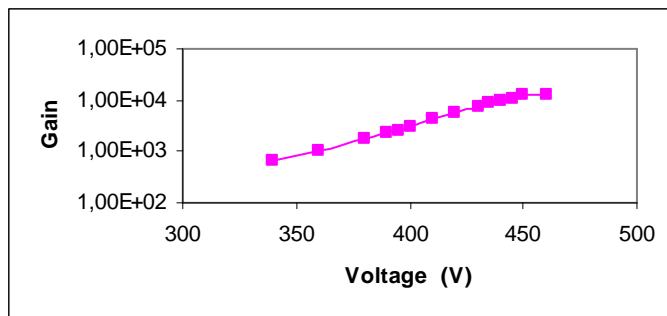

Figure 7. Gain vs. voltage measured in Ne with RETGEM type -1 with $1 \text{ M}\Omega/\square$ resistivity. The radioactive source was ^{55}Fe .

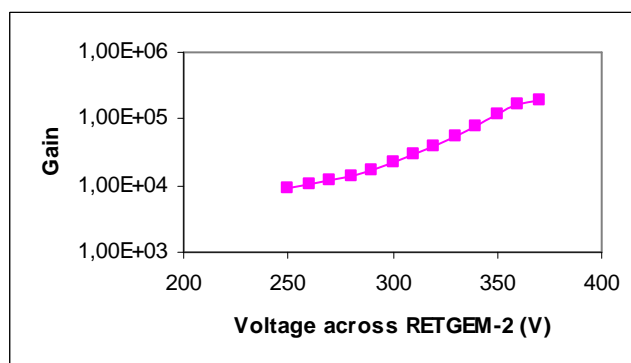

Figure 8. Gain curve measured with double RETGEM (type- $1,1\text{M}\Omega/\square$) operating in Ne. In these measurements the voltages to the RETGEM's electrodes were applied via a resistive divider (see Fig. 5) and the voltage V_{div} was kept at a constant value -800V , which implies a 400V potential drop across RETGEM-1. The radioactive source was ^{55}Fe .

Curve A represents the signal from a charge-sensitive amplifier measured at feedthrough #2 (see figure 5) vs. the negative voltage applied to feedthrough #1. One can see that at $V > 100\text{V}$ the curve reached the saturated level ($S=0.9 \text{ V}$) corresponding to full collection of charges, which were created by the incoming alpha particle in the drift region, on the top electrode of RETGEM-1. Curve B corresponds to measurements of the signal amplitude vs. positive voltage applied to the bottom of RETGEM-1 when the charge sensitive amplifier was connected to feedthrough #3. During these measurements the voltage applied to feedthrough #1 was -300 V and the top electrode of the RETGEM was grounded via feedthrough #2. One can see that at $V > 300 \text{ V}$ avalanche multiplication initiated in the holes of the RETGEM-1. The RETGEM gain (A) can be calculated as:

$$A = G/S, \quad (3.1)$$

where G is the signal amplitude measured at feedthrough #3. As mentioned earlier, our charge-sensitive amplifiers were calibrated by using charge injection method (see [9]) and calculations based on the formula (3.1) allowed us independently verify this calibration.

Figure 7 shows the gain curves measured in Ne with 5.9 keV x-rays (^{55}Fe source).

The operation of the RETGEM at low counting rate ($\leq 100 \text{ Hz}$) was stable, however in the case of a breakdown, presumably due to the charging up effect of the resistive electrodes, the gain vs. voltage may change by a factor of 3-5 and return to its original value after approximately 3-5 min. This behavior is similar to the operation of RPC chambers while in avalanche mode. One should note that in the case of Kapton RETGEM with low $200\text{k}\Omega/\square$ resistivity this effect was much weaker.

Figure 8 and figure 9 show the gain curve for double RETGEMs ($1\text{M}\Omega/\square$ and $0.5\text{M}\Omega/\square$

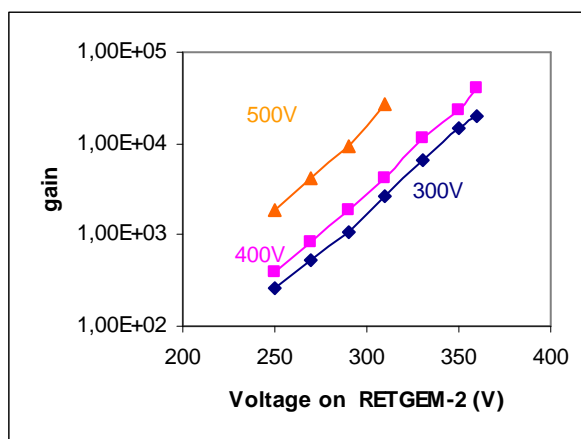

Figure 9. Gain curves for double RETGEMs type-1 with resistivity $0.5M\Omega/\square$ for various voltage drops (indicated in the figure by numbers) across the top RETGEM.

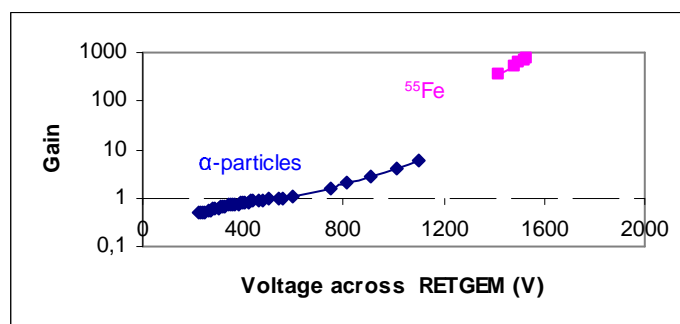

Figure 10. Gain vs. voltage measured in Ar with 5.49MeV alphas and 5.9keV x-rays. RETGEM type-1 with $1M\Omega/\square$ resistivity.

respectively) acting as a cascade vs. voltage applied across the RETGEM-2. The gap between two RETGEMs was approximately 3mm. One can see that gains approaching 10^5 could easily be achieved with ^{55}Fe in Ne gas. At higher gains discharges sometimes appeared; however, due to the high resistivity of the electrodes, these discharges as in the case of Kapton RETGEMs did not harm either the detector or the preamplifiers.

3.2 Tests in Ar and Ar+CO₂

Similar results were obtained in Ar and Ar+CO₂. Figure 10 and figure 11 display the gain curves measured with a single-step RETGEM (type-1 and type-2 respectively) in Ar as function of the voltage applied across the RETGEM. One can see that with ^{55}Fe gains of approximately 10^3 could be achieved in both detectors; however, the type -2 detector offered lower operating voltages. Figure 12 shows the gain curve for RETGEM type-1 operating in Ar+5%CO₂ gas mixture. The energy resolution measured in Ar and Ar+CO₂ gas mixtures as in the case of the Kapton RETGEM (see [13]) was 30-33% FWHM. Gains nearly ten folds higher were achieved with a double-step RETGEM configuration. As an example, figure 13 and figure 14 show the gain curves measured with double RETGEMs operating in Ar and Ar+3%CO₂, respectively. One can see that gains close to 10^4 were possible to achieve. Any discharges that appeared at higher gains were not harmful; thus, our detectors, as in the case of Kapton RETGEMs, were fully spark protected.

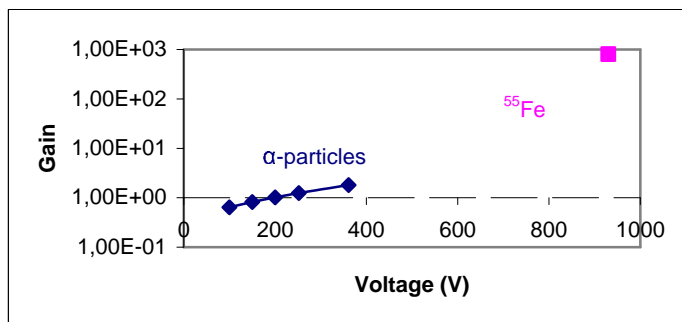

Figure 11. Gain vs. voltage measured in Ar with 5.49MeV alphas and 5.9 keV x-rays. RETGEM type-2.

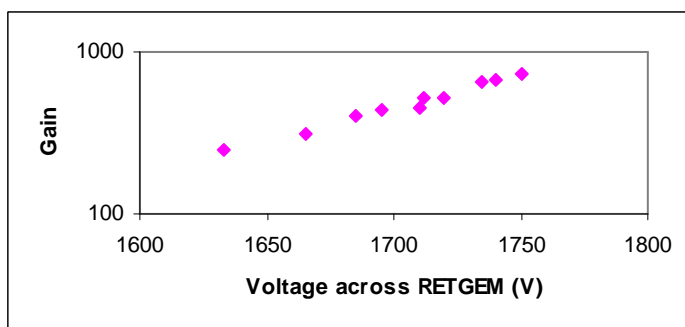

Figure 12. Gain vs. voltage measured in Ar+5%CO₂ with ⁵⁵Fe. RETGEM type-1, 1MΩ/□.

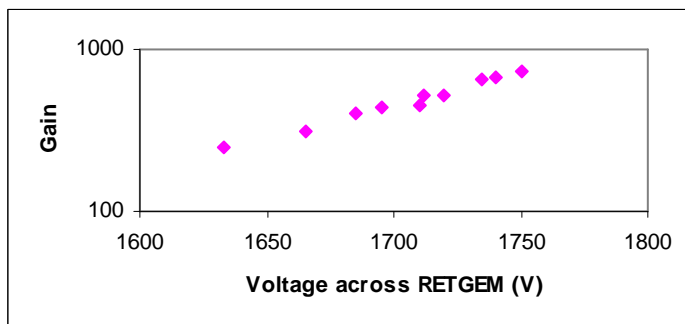

Figure 13. Gain vs. voltage curves measured in Ar with double-step RETGEM type-1 with MΩ/□ resistivity for various V_{div} : 2420V, 2300V, or 2100. Note that V_{div} corresponds to the voltage applied to the voltage divider (see figure 5).

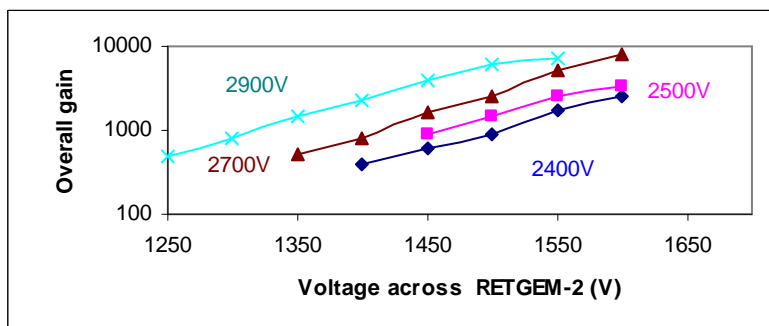

Figure 14. Gain vs. voltage curves measured in Ar+3%CO₂ with double step RETGEM type-1. As in the previous figure, V_{div} corresponds to the voltage applied to the resistive chain divider

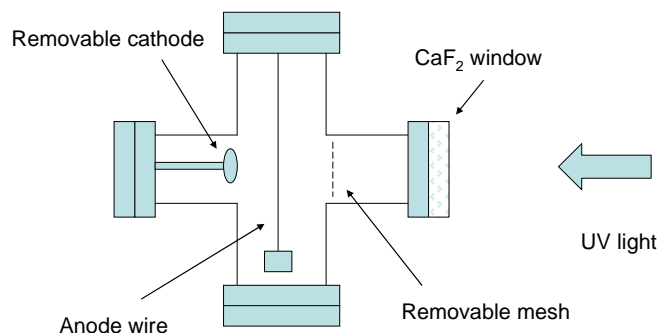

Figure 15. Schematic drawing of the single wire counter flushed with TMAE vapours.

3.3 Tests of photosensitive RETGEMs

In a previous paper [12] we reported that Kapton RETGEM coated with a CsI layer offered high quantum efficiency (QE) for UV. This result inspired the verification of the same effect using screen printed RETGEMs. The setup for studying photosensitive screen printed RETGEMs is shown in figure 5. As in the previous paper [12], the top electrode of the double RETGEM was coated with 0.35 μm thick CsI layer. In contrast to work [12] the quantum efficiency (QE) measurements were performed with the aid of a monochromator. As a reference detector we used a single-wire counter flushed with Ar+10% CO₂+TMAE gas mixture at a total pressure of 1atm (see figure 15) and the gas chamber containing the RETGEM was flushed with one of the following gases at 1atm: Ne, Ar or Ar+10%CO₂. In the case of the single-wire counter the UV light from the monochromator caused the photoionization of TMAE vapours (the depth of the active part of this detector was 4cm, so almost full absorption of the UV light occurs inside its sensitive volume) and created photoelectrons triggered Townsend avalanches near the anode wire. The double RETGEM worked on a principle of the surface photoeffect: the UV light liberated photoelectrons from the CsI layer and these electrons triggered avalanches in the RETGEM holes. The avalanche signals from both detectors were counted using a scaler. The QE of the RETGEM Q_{CsI} was calculated from the following formula:

$$Q_{\text{CsI}} = Q_{\text{TMAE}} N_{\text{RETGEM}} / N_{\text{TMAE}}, \quad (3.2)$$

where Q_{TMAE} refers to TMAE QE and N_{TMAE} and N_{RETGEM} are counting rates from the single-wire counter and from the RETGEM, respectively.

Figure 16 shows the spectra of the Hg lamp measured with the single-wire counter and with the RETGEM. One can see a peak at 185 nm corresponding to the emission line of Hg. Ratio of counting rate at the peak value was ~ 2 which gave the $Q_{\text{CsI}} = 12.2\%$ for this particular case. One should note that, due to the holes, the open area of our RETGEMs was $\sim 40\%$; thus, the expected QE of the CsI coated surface without holes could be as high as 30%, indicating that the quality of the CsI photocathode on the top of the resistive substrate was very good.

The rate characteristics of this detector were similar to rate characteristics of the Kapton RETGEM and at the counting rates used in the QE measurements the pulse amplitudes were not noticeably affected by the aforementioned charging up effect [12].

To independently check these data we also performed measurements in current mode: by measuring the photocurrent produced by the Hg lamp in the single-wire counter and from the top RETGEM-1 electrode. In the latest case, the picoammeter was connected to feedthrough #1 and the negative voltage was applied to the RETGEM-1 top electrode.

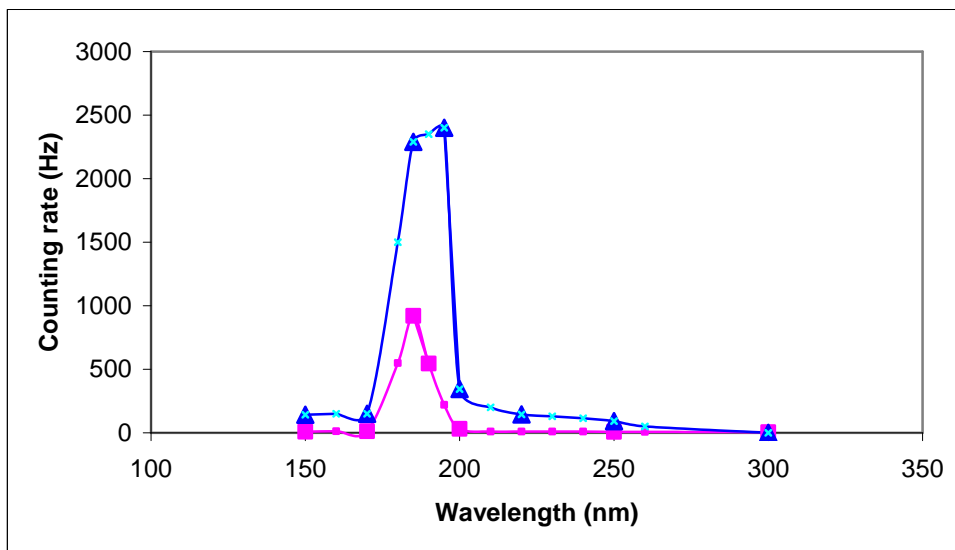

Figure 16. Spectra of Hg lamp measured with a TMAE filled single wire counter (triangles) and with double RETGEM combined with CsI photocathode (squares).

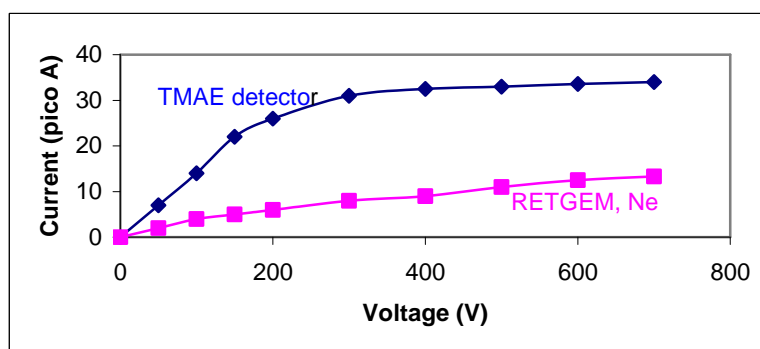

Figure 17. Current vs. voltage measured in the case of the TMAE-filled detector and the RETGEM.

The results are presenting in figure 17. One can see that the ratio of two current values at voltages corresponding to saturation of the curves was ~ 2.5 giving the CsI QE around 12%, which compares to the data obtained in counting mode.

Of course the results presented above have practical importance only if the CsI photocathode evaporated on the top of the resistive material remains stable with time. The results of the stability measurements are presented in figure 18. No noticeable degradation with time was observed over a three-month period indicating that that the photocathode will likely maintain stability for a long time period.

4. Conclusions

Preliminary experimental results presented in this paper haven proven that RETGEM manufactured by a screen printing technology can operate at rather high gains, even in poorly quenched gases. Most importantly, screen printed RETGEM maintains the promise of being fully spark protected. More tests are certainly needed to fully understand some details in the RETGEM operation. However, it is already clear that screen printing technology offers a new

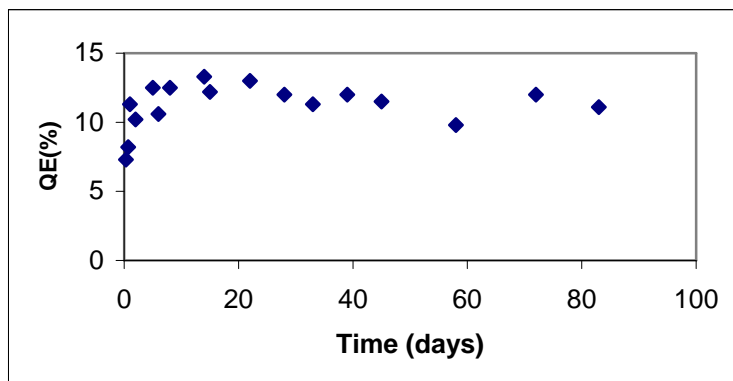

Figure 18. QE of the double RETGEM combined with CsI photocathode vs. time.

and desirable approach to RETGEM manufacturing by offering cost-effectiveness, convenience, and easy optimization of its resistivity and geometry. It is also important to mention that large-area RETGEMs can be produced by this technology. Thus, RETGEMs made by a screen printing technique may open new avenues in both experimental and practical application.

Acknowledgements

We would like to thank J. Van Beelen and M. Van Stenis for their help. One of us (A. G. Agócs) was supported by grant NK62044 of the Hungarian OTKA.

References

- [1] A. Del Guerra et al., *High resistance lead glass tubing for rich counters and for electromagnetic calorimeters*, *Nucl. Instrum. Meth. A* **257** (1987) 609.
- [2] H. Sakurai et al., *A new type of proportional counter using a capillary plate*, *Nucl. Instrum. Meth. A* **374** (1996) 341.
- [3] F. Sauli, *GEM: A new concept for electron amplification in gas detectors*, *Nucl. Instrum. Meth. A* **386** (1997) 531.
- [4] V. Peskov et al., *First attempts to combine capillary tubes with photocathodes*, *Nucl. Instrum. Meth. A* **433** (1999) 492;
S. Giunji et al., *Micro capillary glass plates as a gaseous detector of photons and particles*, *Nucl. Instrum. Meth. A* **477** (2002) 8.
- [5] M. Balcerzyk et al, *Methods of preparation and performance of sealed gas photomultipliers for visible light*, *IEEE Trans. Nucl. Sci.* **50** (2003) 847.
- [6] L. Ropelewski, *New GEM Detectors for Tracking and Triggering*, *Report at the Vienna Conf on Instrum*, <http://vci.oeaw.ac.at/2007/>.
- [7] L. Periale et al., *Detection of the primary scintillation light from dense Ar, Kr and Xe with novel photosensitive gaseous detectors*, *Nucl. Instrum. Meth A* **478** (2002) 377.
- [8] J. Ostling et al., *Study of hole-type gas multiplication structures for portal imaging and other high count rate applications*, *IEEE Trans. Nucl. Sci.* **50** (2003) 809.

- [9] V. Peskov et al., *Development and first tests of GEM-like detectors with resistive electrodes*, *IEEE Trans. Nucl. Sci.* **54** (2007) 1784.
- [10] C. Shalem et al., *Advances in thick GEM-like gaseous electron multipliers-Part-1 atmospheric pressure operation*, *Nucl. Instrum. Meth. A* **558** (2006) 475.
- [11] J.M. Bidault et al., *A novel UV photon detector with resistive electrodes*, *Nucl. Phys. B (Proc. Suppl.)* **158** (2006) 199.
- [12] A. Di Mauro et al., *Development of innovative micro-pattern gaseous detectors with resistive electrodes and first results of their applications*, *Nucl. Instrum. Meth. A* **581** (2007) 225.
- [13] R. Oliviera et al., *First Tests of Thick GEMs with Electrodes Made of a Resistive Kapton*, 1-10 January 2007, [physics/0701154](https://arxiv.org/abs/physics/0701154).