

THE BEAM POSITION SYSTEM OF THE CERN NEUTRINO TO GRAND SASSO PROTON BEAM LINE

T. Bogey, R. Jones, CERN, Geneva, Switzerland

Abstract

The CERN Neutrino to Gran Sasso (CNGS) experiment uses 400GeV protons extracted from the SPS, which travel along 825 meters of beam line before reaching the CNGS target. This beam line is equipped with 23 BPMs capable of measuring both the horizontal and vertical position of the beam. The final BPM is linked to the target station and due to radiation constraints has been designed to work in air.

This contribution will give an overview of the BPMs used in the transfer line. It will also provide a detailed explanation of their logarithmic amplifier based acquisition electronics, which consists of an auto-triggered sequencer controlling an integrator, the A/D conversion and the Manchester encoded transmission of the digital data to the surface. At the surface the digital data is acquired using the Digital Acquisition Board (DAB) developed by TRIUMF (Canada) for the LHC BPM system.

Results from both laboratory measurements and beam measurements during the 2006 CNGS run will also be presented.

INTRODUCTION

The primary protons beam is extracted from the CERN-SPS with a fast kicker system in two batches of 10.5 μ s each, with 50 ms time between the two extractions and travel along the TT40/41 transfer line before reaching the CNGS target. This beam line is equipped with 4 large aperture stripline pick-ups (BPK), 18 button electrode pick-ups (BPG) and one target station stripline pick-up (BPKG). All these monitors are capable of measuring both the horizontal and vertical position of the beam.

The beam position for all of these monitors is obtained using an auto-triggered logarithmic amplifier based acquisition system.

BPM REQUIREMENTS

Table 1: CNGS BPMs requirements

Source	rms uncertainty	Tolerance
BPM (global accuracy)	0.25 mm	± 0.5 mm
Alignment	0.20 mm	± 0.4 mm
Total	0.32 mm	± 0.6 mm
Intensity Range 1×10^{12} to 3.5×10^{13}		

The specification for the CNGS BPM system is described in [1] and summarised in Table 1. The 2 last monitors in the line and the target monitor have tighter

constraints, requiring a resolution of less than 0.1mm and an absolute precision of ± 0.2 mm. This comes from the fact that these monitors are used to centre and keep the beam on the 5mm diameter target rods.

The electronics were therefore designed to comply with the tighter constraints given by these last 3 monitors.

BEAM POSITION MONITORS

Beam Line Position Monitors

The first part of the CNGS extraction line from the CERN-SPS (TT40) is shared between the beams extracted to LHC and those destined for the CNGS target. Since the structure of the beam is different for LHC and CNGS the already developed LHC electronics could not be re-used for CNGS, so requiring additional pick-ups. In order to minimise cost, four existing 33cm long stripline pick-ups were modified as shown in Figure 1, to produce two shorted 11cm stripline pick-ups. This allowed the LHC electronics to be connected to the upstream port and the CNGS electronics to the downstream port.

For the main part of the line (TT41) it was decided to use the same button electrode pick-ups as had already been used in the two 3km SPS to LHC transfer lines. These are 60mm diameter pick-ups using recuperated LEP buttons.

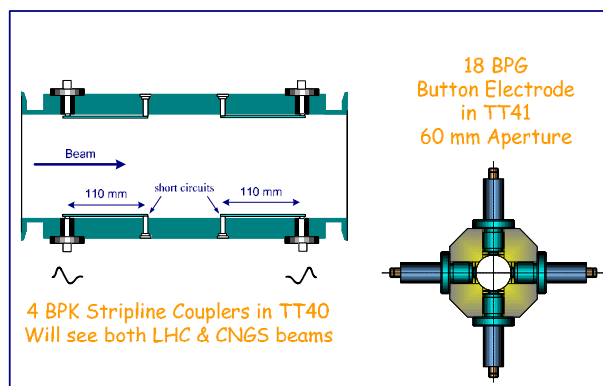

Figure 1: TT40 BPK & TT41 BPG.

Target Station Monitor

The last monitor of the proton line (see Figure 2) is linked to the target station where radiation levels are expected to exceed 5×10^6 Gy per year. This makes access to this zone impossible, so requiring a simple and robust design. This, along with the fact that it was difficult to obtain vacuum windows capable of withstanding the beam power at this location, led to the proposal to use a stripline pick-up working in air. Tests in both the CERN-PS Booster and the CERN-SPS have shown that such an

electromagnetic monitor is much less susceptible to the effect of air ionisation than an electrostatic button monitor.

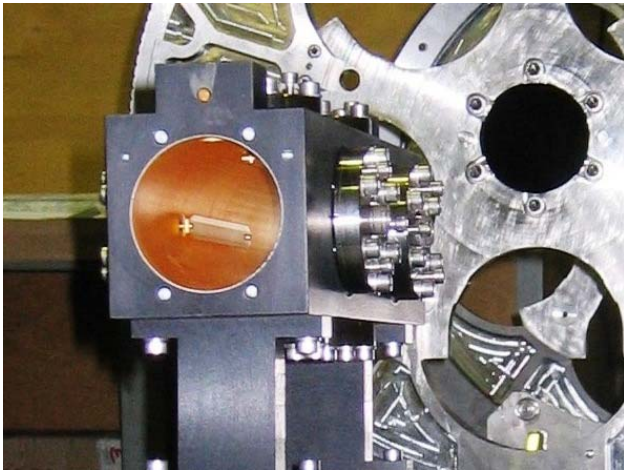

Figure 2: BPKG Target Station Monitor.

Due to the high radiation environment special care had to be taken have taken for this construction. The pick-up body and electrodes were made of an aluminium alloy to lower the remnant radiation. A 30µm gold layer was deposited on the inner surface to maintain a good conductivity while withstanding the effects of radiation. For the outer surface a black penetrating oxide layer treatment was chosen to give thermal stability while withstanding radiation effects.

All 8 ports of the target station monitor were connected to a patch panel outside the target shielding using 3m semi-rigid silicon dioxide cables. The connection of the four downstream ports allows calibration signals to be injected directly into the pick-up, something which is important to study any radiation induced effects.

THE CNGS BPM ELECTRONIC SYSTEM

The decision was taken to use logarithmic processing for the CNGS BPM electronics. This was motivated by four main reasons:

- The possibility of basing the system on an existing design used to measure similar beams in the PS to SPS transfer line [2].
- Its low cabling cost as only 1 coaxial cable is required per pick-up.
- Its inherent large dynamic range without requiring gain switching.
- The possibility of auto-triggering the system, making the system much more robust against external timing issues.

The Logarithmic Amplifier Concept

The signal from each electrode is filtered, compressed by a logarithmic amplifier and applied to a differential amplifier [2]. The position response for such a system is given by:

$$\text{Position} = [\log(A/B)] = [\log(A) - \log(B)] = (V_{\text{out}})$$

Where A and B are the inputs and V_{out} is the voltage after the differential amplifier. This can be shown to give a near linear response close to the pick-up centre, becoming non-linear as the position moves further away from the centre (see figure 4).

The Front-End Design

A schematic of the front-end is shown in Figure 3. It is based on an Analog Devices Limiting-Logarithmic Amplifier (AD8306) and a CERN designed fast switchable slope integrator.

The incoming signals are first split, with one part used for the autotrigger detection and the other filtered using a 200MHz bandpass filter (the frequency corresponding to the 200MHz frequency structure of the beam). The filtered signals pass through the logarithmic amplifiers and are either combined using differential amplifiers to give a position dependent signal or summed to give an intensity dependent signal. These three signals (horizontal & vertical position and total intensity), are then integrated before being converted into digital signals using a four

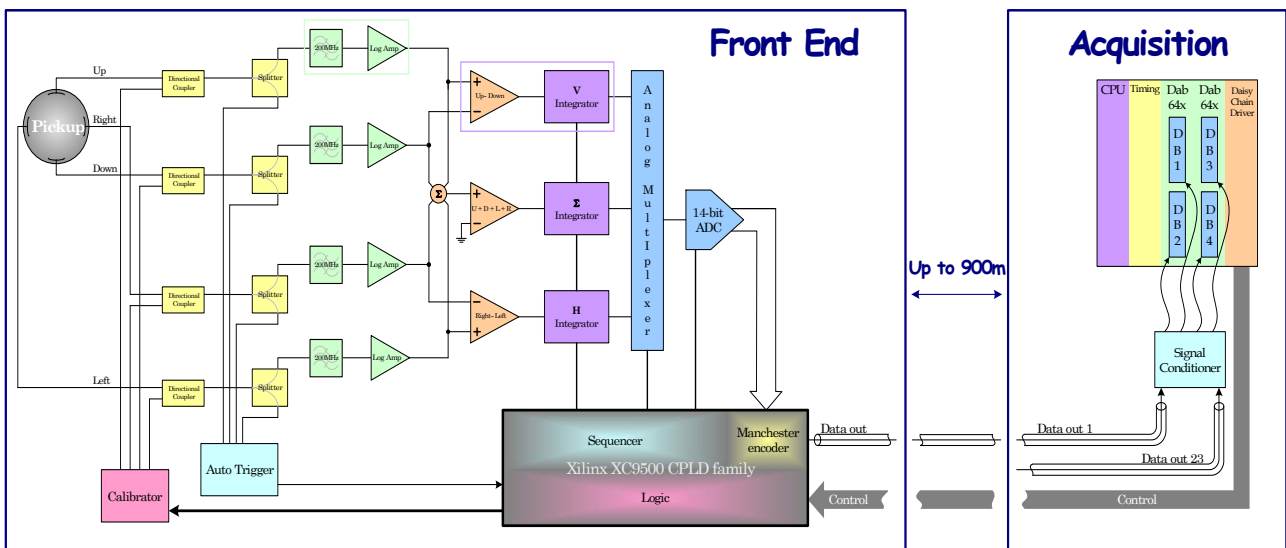

Figure 3: Front End electronics

channel simultaneous sampling 14-Bit ADC (AD7865).

An In-System Programmable CPLD (Xilinx XC95144) is used for the control of the card and contains the following modules:

- Auto trigger conditioner
- Integrator gate & reset generator
- ADC timing conversion sequence controller
- Manchester encoder
- Calibration trigger generator
- General control

The resulting digital data is Manchester encoded and serially transmitted from the front-end to the surface via a coaxial cable link.

The Digital Acquisition System

The digital acquisition system was based around the standard LHC BPM digital VME64x acquisition card (DAB64x), developed by TRIUMF, Canada [3]. Each of these cards is equipped with two mezzanine cards, with each mezzanine card capable of processing the data from six front-ends. Each mezzanine card performs the Manchester decoding of the data from up to six front-ends, and uses a Xilinx FPGA to take care of the timing and to convert the data it into the correct format for the DAB64x.

In the final CNGS configuration, two DAB64x cards, each with two mezzanines process the data from the 23 CNGS pick-ups.

RESULTS

Laboratory Results

Figure 4 shows the effect of combining logarithmic amplifier electronics with an electrostatic button pick-up. It can be seen that in this case the non-linearities are of opposite sign, leading to a resultant function which is linear to better than 1% over much of the aperture.

This was confirmed in a test-bench set-up using the final electronics, where an antenna was displaced along one axis in a replica of the CNGS button pick-up (Figure 5). It can be seen that without applying any linearisation function the position error stays below 1% over one third of the aperture.

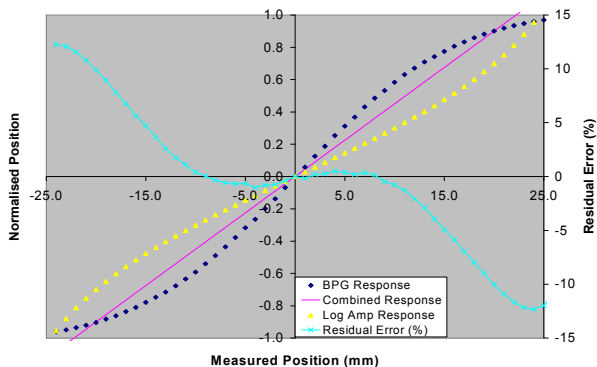

Figure 4: Combining a Button Pick-Up with a LogAmp Acquisition System.

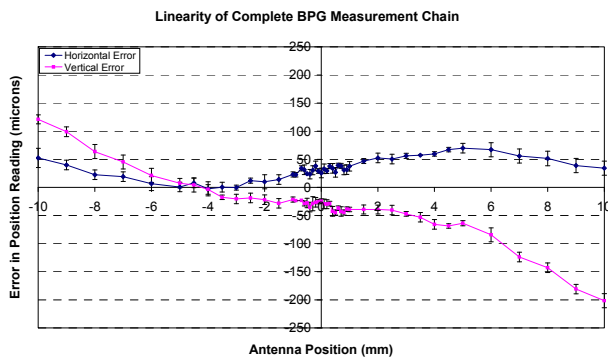

Figure 5: Laboratory Results of BPM System.

First results with Beam

Figure 6 shows the performance of the target station monitor that was used to align the beam on the target. It can be seen that in the vertical plane the measured rms stability of 15 μm is close to the noise level of the electronic system (1 ADC bit $\sim 7 \mu\text{m}$). In the horizontal plane, however, the performance is dominated by beam stability, mainly coming from the non-reproducibility of the horizontal SPS extraction kicker.

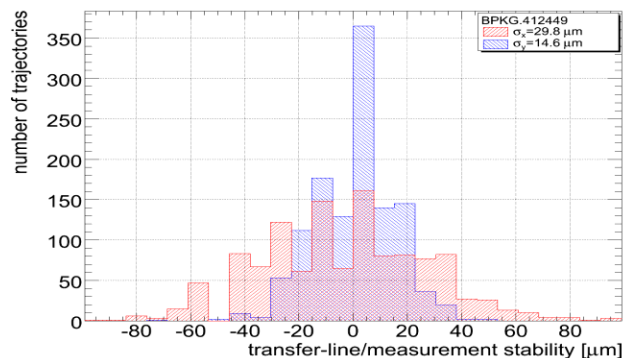

Figure 6: Stability of the target station BPM reading.

CONCLUSIONS

The logarithmic amplifier based CNGS beam position measurement system was successfully commissioned during the 2006 CERN-SPS run. A global accuracy for nominal beams of better than 250 μm over $\pm 10\text{mm}$ was achieved with a resolution at the 20 μm level [4].

REFERENCES

- [1] J-P. Koutchouk, Beam Measurements for the CNGS Beam Line, CERN EDMS No. 376330.
- [2] H. Schmickler, G. Vismara, A logarithmic processor for beam position measurements applied to a transfert line at CERN, DIPAC2001 PM10
- [3] VME64x Digital Acquisition Board for the LHC trajectory and closed orbit system, LHC-BP-ES-0002, CERN EDMS No. 410295.
- [4] T. Bogey et al, Operational Experience with the CNGS beam position monitoring system, NBI2006 <http://proj-cngs.web.cern.ch/proj-cngs/Publications/Publications.htm>