

Volume Reflection of a Proton Beam in a Bent Crystal

Yu. M. Ivanov,^{1,*} A. A. Petrunin,¹ V. V. Skorobogatov,¹ Yu. A. Gavrikov,¹ A. V. Gelamkov,¹ L. P. Lapina,¹
A. I. Schetkovsky,¹ S. A. Vavilov,¹ V. I. Baranov,² Yu. A. Chesnokov,² A. G. Afonin,² V. T. Baranov,² V. N. Chepegin,²
V. Guidi,³ W. Scandale,⁴ and A. Vomiero⁵

¹Petersburg Nuclear Physics Institute, 188300 Gatchina, Leningrad Region, Russia

²Institute of High Energy Physics, 142281 Protvino, Moscow Region, Russia

³Dipartimento di Fisica and INFN, Università di Ferrara, Via Saragat 1/C, 44100 Ferrara, Italy

⁴European Organization for Nuclear Research, CERN, CH-1211 Genève 23, Switzerland

⁵Laboratori Nazionali di Legnaro, Viale dell'Università 2, 35020 Legnaro (PD), Italy,

and CNR-INFN and Brescia University, Via Valotti 9, 25133 Brescia, Italy

(Received 24 February 2006; published 5 October 2006)

Volume reflection predicted in the mid-1980s by Taratin and Vorobiev has been observed for the first time in the interactions of a 70 GeV proton beam with a short bent crystal. Incident protons deviate from convex atomic planes in the bulk of the crystal as a result of coherent interaction with bent lattice around the tangency point of particle trajectory with a curved atomic plane. The deflection angle $2\theta_R$ was found to be $(39.5 \pm 2.0) \mu\text{rad}$, or $(1.65 \pm 0.08)\theta_c$ in terms of the critical angle for channeling. The process has a large probability with respect to channeling and takes place in the angular range equal to the bend angle of atomic planes. It could possibly open new fields of application of crystals in high-energy particle beam optics.

DOI: 10.1103/PhysRevLett.97.144801

PACS numbers: 29.27.-a, 61.85.+p

Charged particles, incident to a properly oriented bent crystal, can be captured in the channeling regime and follow the crystal curvature, deviating from the initial path [1]. Capture occurs with the particles traveling in a direction tangential to the atomic planes. As the tangency point lies at the entry face of the crystal a *surface capture* occurs, while for *volume capture* the tangency point is inside the crystal volume. It was found [2] that only a small part of the particles with the appropriate parameters for being volume captured are indeed channeled. Non-volume-captured particles were called *reflected* particles by Sumbaev [3].

In the mid-1980s, Taratin and Vorobiev developed an accurate model of the particle motion in the bent crystal and studied with this model the volume capture process. They explained [4] the volume capture as a result from the multiple scattering of the incident particles on electrons and nuclei of the crystal material. But in addition to the volume capture process, they found [5,6] that interaction of the particles with the continuous periodical potential of the bent crystal lattice in the vicinity of the tangency point should lead to an angular deflection of the reflected particles, almost twice the channeling critical angle in the direction, opposite the atomic plane bending. They called this process a *volume reflection effect*.

We have carried out a crystal channeling experiment at IHEP (Protvino) in which we observed, in the first time, the volume reflection phenomenon. In this Letter, we present a main result of the experiment; the more detailed description of the study can be found in [7].

In the experiment we applied a very short (0.72 mm along the beam) bent silicon crystal prepared using the

elastic quasimosaicity effect [8–10]. This effect originates from crystal anisotropy and results in curving of the normal cross sections of the crystal plate under bending. The crystal plate was cut from silicon ingot as described in [11]. The plate sizes were $0.72 \times 20 \times 60 \text{ mm}^3$, with the channeling (111) planes parallel to the $0.72 \times 60 \text{ mm}^2$ face. The plate was bent in the YZ plane with a radius of curvature of 48 cm (Fig. 1) inducing a quasimosaic curvature of the atomic (111) planes in the XZ plane with an estimated radius of 1.7 m and a corresponding full curvature angle of $423 \mu\text{rad}$.

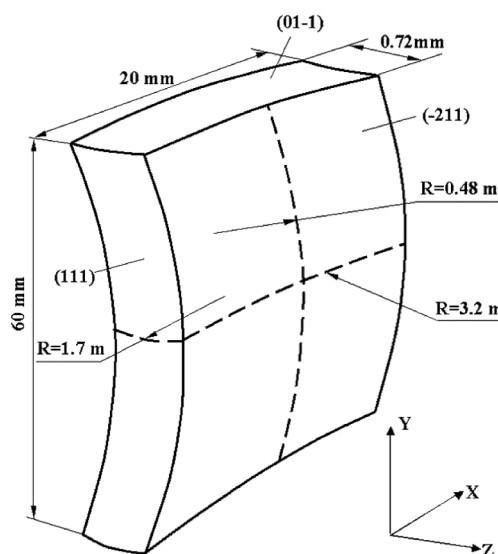

FIG. 1. Bent crystal used in the experiment. Proton beam crosses the crystal in the Z direction.

The surface and the volume properties of the crystal were investigated with x rays. The bend angle of atomic (111) planes was found to be equal to $(413 \pm 10) \mu\text{rad}$. The thickness of the damaged layer of the crystal surface was measured to be less than $1 \mu\text{m}$. A saddle shape of the major crystal face induced by anticlasic forces was studied in details; the saddle radius in the horizontal XZ plane crossing the center of the crystal was found to be 3.2 m, slightly increasing in the Y direction (closer to the clamps).

In the experiment we used a small-divergent ($\sim 15 \mu\text{rad}$), low intensity ($\sim 10^5 \text{ s}^{-1}$), 70 GeV proton beam described in [12]. The angular spreading of the beam induced by multiple scattering in the crystal plate was about $13.5 \mu\text{rad}$. Both the divergence of the incident beam and the multiple scattering in the crystal were negligible with respect to the critical angle for channeling θ_c equal to about $24 \mu\text{rad}$ in our case. Just under these conditions, a volume reflection becomes the leading effect in beam-crystal interaction.

The crystal was mounted on a turntable providing 4 mm overlapping with the proton beam in the X direction (Fig. 2). Alignment of the crystal was done using a reflection of laser beam from crystal faces to the marks related with proton beam. Channeling orientation of the crystal was found as an angular position with the maximal coincidence rate between narrow scintillation counters S1 and S2 placed in and out of the primary beam, respectively. A large counter S3 was used as a primary beam monitor.

The profile of the beam transmitted through the oriented crystal was measured using emulsions of the R-100 type located 4.6 and 5.9 m downstream. They were exposed to an integrated flux of about 5 particles/ μm^2 and displayed three distinct slightly curved lines A, B, and C well visible in a wide background spot from primary beam having a semicircle shape due to cutting a beam by collimator. The measured profiles were similar in both emulsions, but separation of lines was largest in the most distant emulsion, which is shown in Fig. 3.

Let us consider phenomena that occur with protons hitting the crystal near the horizontal XZ plane crossing the crystal center (Fig. 4). The crystal shape in this

plane is slightly curved by anticlasic forces. As a consequence, the (111) planes have a changing orientation along the X direction shown in a largely exaggerated manner in Fig. 4.

In a small X range where incident protons are tangent to the (111) planes on the entry face, more than half of the protons transiting through this range are captured in the channeling and deflected by a bend angle of (111) planes (rays between 5 and 6) producing a spot denoted by C.

For points at larger X coordinates, the conditions are adequate for volume reflection, since the trajectories of the incident protons are tangent to the atomic (111) planes somewhere inside the crystal. Should volume reflection occur with a probability close to 1, then all these proton trajectories will deviate by about twice the critical angle θ_c , in the opposite direction with respect to the channeling one (rays between 1 and 3).

Out of the X ranges for channeling and volume reflection, incident protons pass through the crystal and experience only multiple scattering (rays above ray 4 and below 2). In this case, there is an area depleted of protons in between the reflected and the primary beam, denoted by B, and another area where primary and reflected protons mix, denoted by A.

In examining crystal slices parallel to the X axis at different heights above or below the midplane, we expect the same picture of the proton-crystal interactions, except that the vertical dependence of the anticlasic curvature should produce a continuous shifting of the projected spots. From this analysis, a joint pattern should comprise two black lines A and C and one light line B of the same slightly curved shape. Just these lines were observed in the experiment.

For both emulsions we determined the relative positions and widths of the observed lines in the X direction of the crystal midplane by identifying the borders of the various spots with a microscope (i.e., we identified rays 1 to 6 along the white dashed lines in Fig. 3). The results are summarized in Table I, having computed the measurement errors as the root-mean-square of repeated measurements combined with a reading error of $5 \mu\text{m}$. Numerous cross-

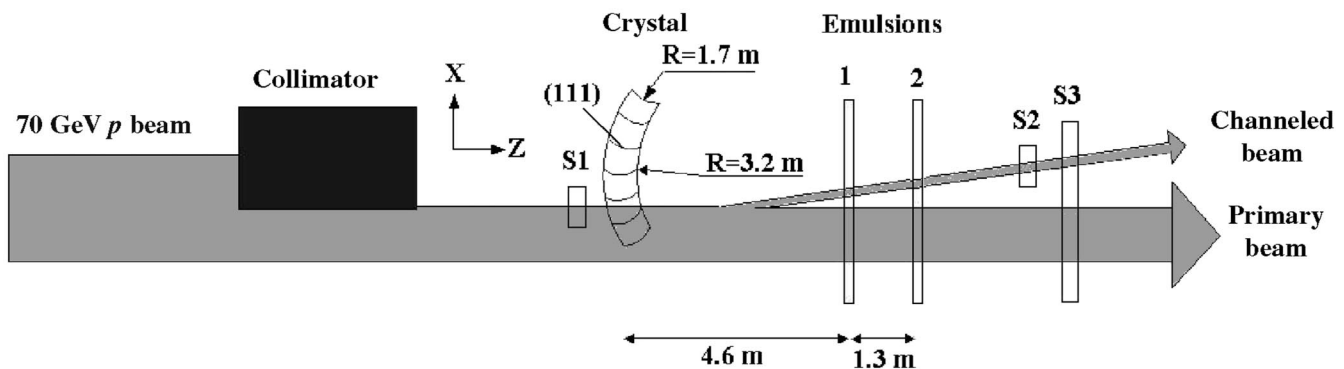

FIG. 2. Layout of the experiment. S1, S2, S3—scintillation counters.

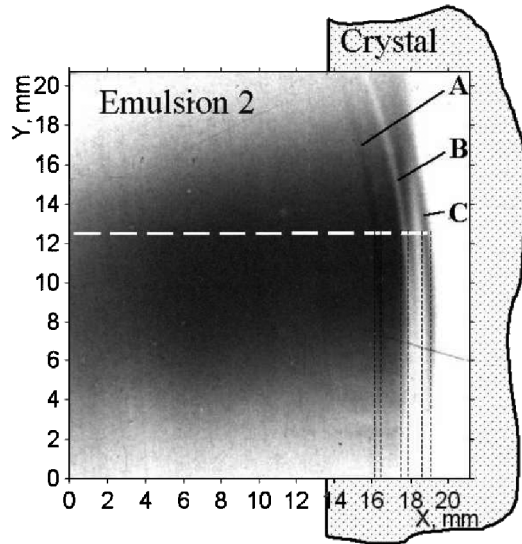

FIG. 3. Part of emulsion 2 with the profile of the proton beam. The white dashed line indicates the trace of the measurement with a microscope. The black dashed lines show X readings, which correspond to the borders of the lines A, B, and C.

checks of the results in Table I were performed with the data of other measurements and computed parameters, and evidence of internal consistency was found, confirming the interpretation.

In a first check, we considered the bending angle of the (111) planes and computed it as the ratio of the distance between the lines A and C to the distance between the crystal and the corresponding emulsion. Averaging the data of the two emulsions in Table I, we found a value of $(435 \pm 6) \mu\text{rad}$, in good agreement both with the value of

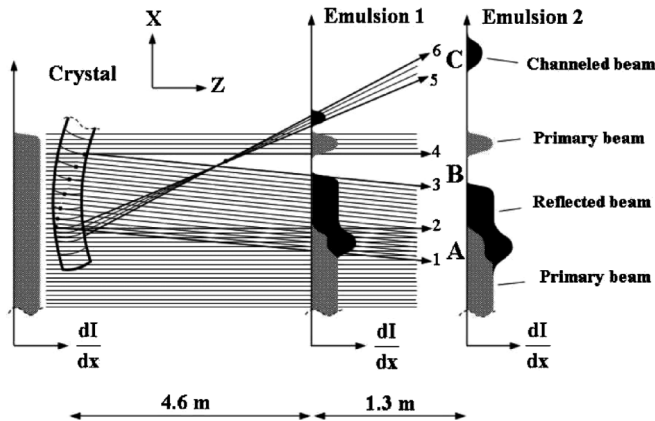

FIG. 4. Proton trajectories crossing the crystal and emulsions in the horizontal plane (top view). The incident beam is shown as parallel (distance between the effective “source” of the beam and the crystal is much larger than a saddle radius of the crystal) with a uniform intensity distribution along the X direction. The dots within the crystal indicate the tangency points of the incident proton trajectories with the (111) atomic planes where volume reflection takes place.

$423 \mu\text{rad}$ calculated from elasticity constants and with the value of $(413 \pm 10) \mu\text{rad}$ measured with x rays.

In a second check, we considered the width of the channeled beam, which is equal to the width of the line C. This width results from the critical angle θ_c , the horizontal saddle radius, and the incident beam divergence. The expected width of the line C was estimated to be 297 and $430 \mu\text{m}$ in the emulsions 1 and 2, respectively, in agreement with measured values in Table I.

In a third check, we considered the width of the reflected beam, which is equal to the distance between the lines A and B. This distance results from the bend angle of (111) planes, the horizontal saddle radius, and the incident beam divergence. The expected distance between the lines A and B was estimated to be 1432 and $1507 \mu\text{m}$ in the emulsions 1 and 2, respectively, with an estimated error of about $50 \mu\text{m}$ (mostly induced by the inaccurate knowledge of the beam parameters). These values are in excellent agreement with those of Table I.

Finally, we estimated the deflection angle of the reflected protons from the angular width of lines A and B, defined as the ratio of the line width to the distance from the crystal to each emulsion. Using the data of Table I we can compute the averaged angular widths of A and B, which are equal to $(42.7 \pm 2.3) \mu\text{rad}$ and $(37.2 \pm 3.5) \mu\text{rad}$, respectively. Indeed, the protons of line A are reflected near the entry face of the crystal and will suffer of the multiple scattering along the full crystal length. Hence we should subtract (in a quadratic sense) the rms angle of $13.5 \mu\text{rad}$ from the A width. Finally, the deflection angle $2\theta_R$ was calculated as an average of the widths of A and B and found equal to $(39.5 \pm 2.0) \mu\text{rad}$, or $(1.65 \pm 0.08)\theta_c$ in terms of the critical angle for channeling, in good agreement with the value predicted by Taratin and Vorobiev.

From the color of line A, we can conclude that the probability of the reflection is larger than the probability of the channeling. Indeed, spot A in the emulsions results from two coexisting phenomena: the incident flux directed towards A is depleted by the channeling effect, while it is enhanced by the reflection effect. The dark color of spot A corresponds to an excess of particles respect to the surrounding areas. In our case the channeling probability is about 0.6; we therefore expect a somewhat higher frequency for the reflection process. From the acuteness of

TABLE I. Positions of the line centers and line widths in microns.

Line	Emulsion 1		Emulsion 2	
	Position	Width	Position	Width
A	0 ± 10	190 ± 10	0 ± 11	260 ± 11
B	1420 ± 6	183 ± 19	1447 ± 13	213 ± 16
C	2025 ± 10	260 ± 8	2530 ± 23	433 ± 16

the light line B , we can infer that a deflection angle of the reflected particles has a rather small dispersion.

To conclude, we would like to point out that the distinctive features of the reflection process make it attractive for a new class of applications in particle accelerators. The crystal reflection effect occurs with a higher probability with respect to channeling, allowing a considerably wider angular acceptance, being determined by bend angle of atomic planes (in case of channeling the angular acceptance is determined by critical angle θ_c). To increase the deflection angle of reflected particles we may consider specially prepared crystal arrays or an ensemble of crystals to produce several successive volume reflections, possibly resulting in an efficient particle deflection at a large angle. This approach may improve beam halo cleaning and reduce background in high-energy hadron colliders, thereby increasing the machine reliability, while opening a potential for discovering new processes, such as the diffractive physics studies, or flavor physics in extracted beam.

We are grateful to A. A. Vorobyev and V. I. Kotov for interest and support of the research, and to A. M. Taratin, V. M. Samsonov, V. V. Fedorov, R. A. Carrigan, Jr., V. D. Shiltsev, N. V. Mokhov, and J. Miles for useful discussions and remarks. This work was supported by the Russian Foundation for Basic Research (Grants No. 01-02-17992 and No. 01-02-18005), the “Elementary Particle Physics and Fundamental Nuclear Physics” Program of Russian Academy of Sciences, and the INTAS-CERN Foundation

(Grant No. 03-52-6155).

*Electronic address: yumi@pnpi.spb.ru

- [1] A. F. Elishev *et al.*, Phys. Lett. **88B**, 387 (1979).
- [2] V. A. Andreev *et al.*, Pis'ma Zh. Eksp. Teor. Fiz. **36**, 340 (1982) [JETP Lett. **36**, 415 (1982)].
- [3] O. I. Sumbaev, in *Relativistic Channeling*, edited by Richard A. Carrigan, Jr. and James A. Ellison, NATO ASI, Ser. B, Vol. 165 (Plenum Press, New York, 1987), pp. 117–127.
- [4] A. M. Taratin and S. A. Vorob'ev, Zh. Tekh. Fiz. **55**, 1598 (1985) [Tech. Phys. **30**, 927 (1985)].
- [5] A. M. Taratin and S. A. Vorobiev, Phys. Lett. A **119**, 425 (1987).
- [6] A. M. Taratin and S. A. Vorobiev, Nucl. Instrum. Methods Phys. Res., Sect. B **26**, 512 (1987).
- [7] Yu. M. Ivanov *et al.*, PNPI, Gatchina, Report No. 2649, 2005 (in Russian).
- [8] O. I. Sumbaev, Zh. Eksp. Teor. Fiz. **54**, 1352 (1968) [Sov. Phys. JETP **27**, 724 (1968)].
- [9] V. M. Samsonov, LIYaF AN SSSR, Leningrad, Report No. 278, 1976 (in Russian).
- [10] V. M. Samsonov and E. G. Lapin, LIYaF AN SSSR, Leningrad, Report No. 587, 1980 (in Russian).
- [11] Yu. M. Ivanov, A. A. Petrunin, and V. V. Skorobogatov, Pis'ma Zh. Eksp. Teor. Fiz. **81**, 129 (2005) [JETP Lett. **81**, 99 (2005)].
- [12] Yu. A. Chesnokov, Nucl. Instrum. Methods Phys. Res., Sect. B **119**, 163 (1996).