

# Measurement of the $^{16}\text{O}(n, \alpha)^{13}\text{C}$ cross-section using a Double Frisch Grid Ionization Chamber

Sebastian Urlass<sup>1,2,3,\*</sup>, Roland Beyer<sup>1</sup>, Sebastian Hammer<sup>1,2</sup>, Andreas Hartmann<sup>1</sup>, Arnd R. Junghans<sup>1,3</sup>, Toni Kögler<sup>1,5</sup>, Benjamin Lutz<sup>1</sup>, Federica Mingrone<sup>3,4</sup>, Stefan Müller<sup>1</sup>, Katja Römer<sup>1</sup>, Daniela Scheibler<sup>1</sup>, Daniel Stach<sup>1</sup>, Tamás Szücs<sup>1</sup>, Laurent Tassan-Got<sup>3,4,6</sup>, Steffen Turkat<sup>1,2</sup>, Andreas Wagner<sup>1</sup>, David Weinberger<sup>1</sup>, and the n\_TOF Collaboration<sup>7</sup>

<sup>1</sup>Helmholtz-Zentrum Dresden-Rossendorf (HZDR), Bautzner Landstraße 400, 01328 Dresden, Germany

<sup>2</sup>Technische Universität Dresden (TUD), 01062 Dresden, Germany

<sup>3</sup>European Organization for Nuclear Research (CERN), Route de Meyrin 1211, Genève, Switzerland

<sup>4</sup>National Technical University of Athens (NTUA), Zografou Campus 9, Iroon Polytechniou Str, 15780 Zografou, Greece

<sup>5</sup>Onco Ray - National Center of for Radiation Research in Oncology, Händelallee 26, 01309 Dresden, Germany

<sup>6</sup>Institute de Physique Nucleaire (IPN), rue Georges Clemenceau, 9406 Orsay, France

<sup>7</sup><https://www.cern.ch/ntof>

**Abstract.** The  $^{16}\text{O}(n, \alpha)^{13}\text{C}$  reaction was proposed to be measured at the neutron time-of-flight (n\_TOF) facility of CERN. To this purpose, a Double Frisch Grid Ionization Chamber (DFGIC) containing the oxygen atoms as a component in the counting gas coupled with a switch device in order to prevent the charge collection from the so-called  $\gamma$ -flash has been developed at Helmholtz-Zentrum Dresden-Rossendorf (HZDR), in Germany. The first  $^{16}\text{O}(n, \alpha)^{13}\text{C}$  measurement without seeing the charge of the  $\gamma$ -flash at n\_TOF has been performed in November 2018. After the electronics did not suffer from the  $\gamma$ -flash any more, another huge charge collection was discovered. Due to the high instantaneous flux at the n\_TOF facility [1] the amount of that induced charge from neutron induced background reactions was piling up so much that the recognition of  $^{16}\text{O}(n, \alpha)^{13}\text{C}$  reactions from that background was very difficult. For that reason another  $^{16}\text{O}(n, \alpha)^{13}\text{C}$  measurement at the time-of-flight facility nELBE at HZDR which has a low instantaneous flux [2], has been performed in April 2019. Both measurements from n\_TOF and nELBE will be presented here.

## 1 Introduction

The  $^{16}\text{O}(n, \alpha)^{13}\text{C}$  cross-section reaction measurement plays an important role for nuclear technology, as pointed out by the CIELO Collaboration [3]. Discrepancies up to 30% in the measured and evaluated cross-section data affect the prediction of  $k_{\text{eff}}$  for current and innovative reactors, the prediction of helium production in reactors, and the calibration of reference neutron-source strength in metrology measurements [4]. Another aspect of this reaction is the importance in stellar nucleosynthesis processes and its inverse  $^{13}\text{C}(\alpha, n)^{16}\text{O}$  reaction for the understanding of the slow neutron capture process in Asymptotic Giant Branch stars [5]. In order to investigate the experimentally difficult accessible  $^{13}\text{C}(\alpha, n)^{16}\text{O}$  reaction, an indirect method can be used by measuring the  $^{16}\text{O}(n, \alpha)^{13}\text{C}$  reaction cross section and applying the time-reversal invariance theorem.

For these reasons a significant technological effort has been put in the development of a new detection system, with the goal, to apply the experimental technique using a gaseous target in an active volume, which is based on the measurement from 2007 performed at Joint Research Center in Geel, Belgium, in a Van de Graaff facility [6], to

the neutron Time-of-flight facilities n\_TOF and nELBE in an energy range from 3 to 15 MeV.

## 2 Experiment at n\_TOF

In November 2017 the first test of a prototype DFGIC, which has been produced at HZDR, has been performed at n\_TOF in the experimental area called EAR1 - with a horizontal flight path of 185 m. There, the high energy  $\gamma$ -flash produced in the spallation reactions which is converted into charge particles by crossing the various layers of materials (25  $\mu\text{m}$  thick titanium windows and 6  $\mu\text{m}$  thick aluminized Mylar electrodes), creates such an amount of charge that the preamplifier electronics are blinded. Although the layers of matter in the beam of the new prototype DFGIC were kept as minimal as possible, it was clear that the saturation of the charge sensitive preamplifiers (CSP) due to the  $\gamma$ -flash makes a time-of-flight measurement in the high-energy region impossible. Connecting directly the detector signals to the acquisition system without any preamplification, we measured also the direct current induced by the  $\gamma$ -flash which is about three orders of magnitude higher than for the one induced by  $\alpha$ -particles.

\*e-mail: [sebastian.urlass@cern.ch](mailto:sebastian.urlass@cern.ch)

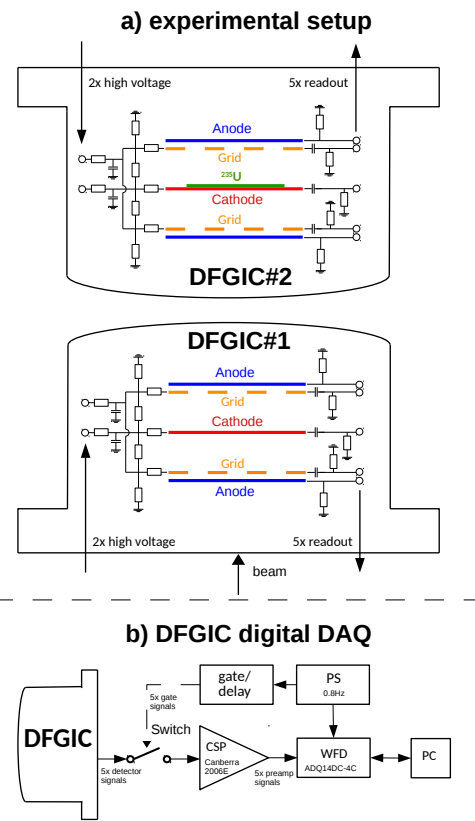
The idea to solve this problem is to put a wideband Switch between the detector and the CSP, in order to prevent the charge collection while the  $\gamma$ -flash passes through the DFGIC. After a series of tests with the Switch device the final configuration for the measurement in November 2018 in EAR1, could be found. The setup, shown in Figure 1 a), consists of two DFGIC's which have been constructed at HZDR. Each DFGIC consists of 5 electrodes (2x Anode, 2x Grid and 1x Cathode). The electrode diameter is 18cm. The Grid-Cathode and the Anode-Grid distance is 40mm and 5mm, respectively. The design of the detector and the housing vessels for the final experiment was based on the need to operate the detector at 3 bars absolute pressure, in order to maximize the areal density of the sample and also to allow a sufficient stopping of  $\alpha$ -particles in the gas. The purpose for using two chambers, with each containing two independent sensitive volumes, is to reduce the statistical uncertainty for the  $^{16}\text{O}(n,\alpha)$  reaction measurement. In addition, one part of the DFGIC contains  $^{235}\text{U}$  and is used to monitor the neutron flux. All detector signals were digitized with waveform digitizers (SPDevice, ADQ14, 14bit), recording each of the 10 detector signals coming from the two chambers, by a digital data acquisition (DAQ), which is illustrated in Figure 1 b). The waveforms were recorded, with an accelerator frequency of 0.8 Hz, up to 1 ms time window with a sampling rate of 250MS/s.

Due to the high instantaneous neutron flux of the facility the pile-up of neutron induced background reactions induces charges in the DFGIC with up to two orders of magnitude higher than one induced by  $\alpha$ -particles. In order to reduce neutron induced background both chambers were operated with reduced pressure of 1.3 bar and neutron filters (3 cm thick lead and 8 cm thick sulfur) has been put in beam. Under this condition signals from fission fragments (coming from the  $^{235}\text{U}$  containing chamber part) which are depicted as an example in Figure 1, could be analysed. Although also  $\alpha$ -particles from the decay of  $^{235}\text{U}$  could be identified, the disturbance of the neutron induced background is still so large that a proper analysis of the  $^{16}\text{O}(n,\alpha)$  reactions in the fast neutron region is not possible.

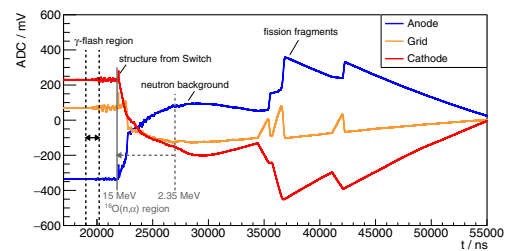
### 3 Experiment at nELBE

The main reason for performing the  $^{16}\text{O}(n,\alpha)$  reaction measurement at nELBE is that the instantaneous flux of neutrons and photons is very low, which means that the expected background induced in the DFGIC per accelerator period is low as well. The setup, illustrated in Figure 3, consists of two DFGIC and a separate fission ionization chamber for monitoring the neutron flux<sup>1</sup>. The two DFGIC's are operated with different pressures - DFGIC#2 at 2.8 bar and DFGIC#1 at 1.5 bar. The latter one was chosen in order to compare DFGIC#1 with the similar pressure condition like at the n\_TOF experiment, whereas DFGIC#2 is used as main chamber.

<sup>1</sup>Due to safety reasons the  $^{235}\text{U}$  in DFGIC#2 has been removed.

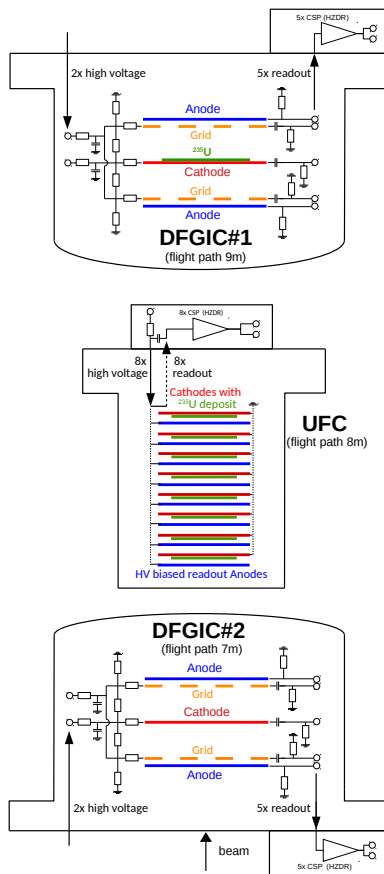


**Figure 1.** Experiment at n\_TOF in EAR1 in November 2018. The experimental setup in a) contains two DFGIC which are both operated with 95% Kr + 5% CO<sub>2</sub> at 1.3 bar pressure. DFGIC#2 contains  $^{235}\text{U}$  and is used as a neutron flux monitor. b) shows the digital DAQ which is used for each DFGIC. A logical accelerator pulse coming from the Proton Synchrotron (PS) of CERN triggers the waveform digitizer (WFD) and the switch.



**Figure 2.** Signal traces from  $^{235}\text{U}$  containing part of DFGIC#2. The  $\gamma$ -flash (dashed black lines) starts at 19  $\mu\text{s}$  and has a total width of 1  $\mu\text{s}$ . The switch let pass the signals, 3  $\mu\text{s}$  after the  $\gamma$ -flash (grey colored line). The dashed grey line indicates the threshold energy of the  $^{16}\text{O}(n,\alpha)$  reaction at 27  $\mu\text{s}$ .

Because of the high accelerator frequency of 100 to 400 kHz, the most challenging part at nELBE was the development of a DAQ system. The DFGIC data analysis requires, besides the amplitude information, also the time information of the start and end of the signal edges [6]. For this purpose the storage of waveforms and analysing the signal edges would be suited. However, the accelerator frequency at nELBE and data rate are quite high that usually a storage of waveforms is very difficult. On the

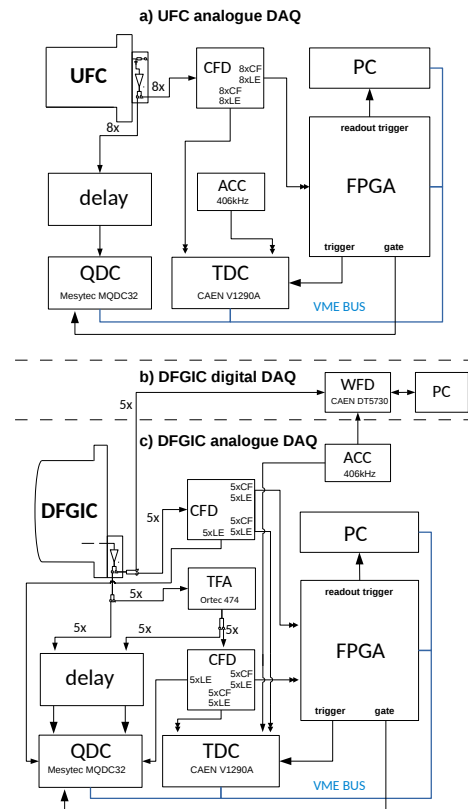


**Figure 3.** Experimental setup at nELBE in April 2019. The two chambers DFGIC#1 (1.5bar) and DFGIC#2 (2.8bar) are operated with 95% Kr+5% CO<sub>2</sub>. A separate uranium fission ionization chamber (UFC [7]), operated with P10 (90% Ar+10% CH<sub>4</sub>) at 1.05 bar, is used to measure the neutron flux. For all ionization chambers CSP's<sup>2</sup> with two signal outputs are used.

other hand, extracting all needed information from the signal edges is difficult to perform with an analogue DAQ. Since it was in advance unclear which type of DAQ would be the best, a complex data acquisition, shown in Figure 4, consisting of both an analogue and digital branch, has been developed.

At nELBE an analogue DAQ, like it is illustrated in Figure 4 a) for the fission ionization chamber, is routinely used. Both the time and energy information are measured by the DAQ in list-mode. The time information is acquired by a time to digital converter (TDC). The charge information is recorded by a charge to digital converter (QDC). The initializing and readout of the TDC- and QDC modules is done by a RIO3 power PC which communicated via a VME BUS. The RIO3 is operated with the Multi-branching System (MBS) which is developed at GSI [8]. The trigger logic of the experiment is implemented in a FPGA module. For the determination of the timing of the signals discriminator modules (CFD<sup>2</sup>) with Constant Fraction (CF) and Leading Edge (LE) outputs are used.

<sup>2</sup>In-house development at HZDR



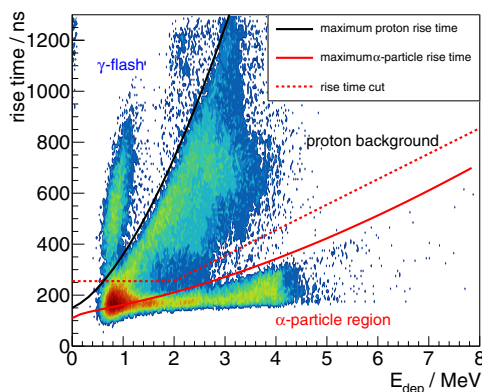
**Figure 4.** DAQ systems at nELBE. The UFC used the analogue DAQ system in a). The DFGIC used both, a digital- and analogue DAQ system, shown in b) and c), respectively. The accelerator pulse (ACC) serves as reference for the time-of-flight measurement.

The analogue DFGIC DAQ, shown in Figure 4 c), uses in addition Timing Filter Amplifiers (TFA) in order to differentiate the CSP signals to current-like signals. From the time over threshold information of these TFA signals the information from the signal edges are extracted. The digital DFGIC DAQ, illustrated in Figure 4 b), uses digitizers (CAEN DT5730, 14bit) to record the waveforms of the 10 DFGIC detector signals with a time window of 3500 ns and a sampling rate of 500 MS/s. Furthermore the time stamp- and amplitude information extracted with the internal firmware of the digitizer were recorded. All the data of the digital DFGIC DAQ is stored as ROOT trees [9]. In the final configuration 6 cm thick lead filters, attenuating the intensity of the  $\gamma$ -flash, in order to reduce the data rate were used. This allowed for the first time at nELBE to run an experiment with a fully working waveform recording digital DAQ, at the maximum accelerator frequency of 400kHz.

For all types of DAQ's the detector signals were independently triggered and correlated with the accelerator. The MBS-list-mode data from the analogue DAQ are analysed with the software package Go4 [10]. Although the internal firmware of the digitizer and Go4 were a good tool for performing an online analysis of the DFGIC signals during the beam time, the informations from that CSP signal edges could not be extracted with sufficient precision.

For this reason the main analysis has been focussed on the stored waveforms of the digital DAQ. First step of the analysis is building the coincidence between Anode, Grid and Cathode signal of the corresponding chamber part. Afterwards a waveform analysis, extracting amplitudes and time stamps of signal start- and end from the edges of Anode and Cathode signal, has been performed. The last step of analysis is the discrimination of  $(n, \alpha)$  reactions from background.

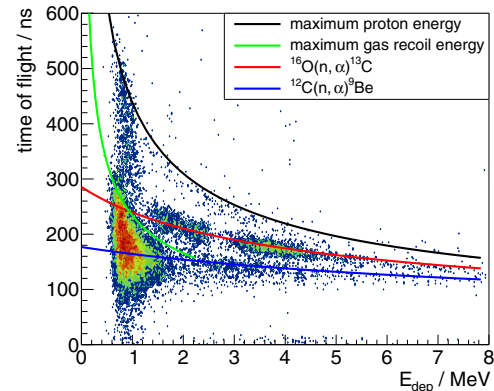
As an example to illustrate the different background contributions a two dimensional Anode rise time versus deposited particle energy spectrum is depicted in Figure 5. The Anode rise time carries the information of the projected particle track inside the Grid-Cathode region. Due to different stopping range behaviour of different particle types,  $\alpha$ -particles are distinguishable from proton- and  $\gamma$ -flash events in a certain energy range. Protons were the main source of the induced background and are mainly produced as  $(n, p)$  reaction on the electrode material. During the experiment part of the electrodes has been changed from  $6\mu\text{m}$  thick aluminized Mylar to  $25\mu\text{m}$  thick titanium. Compared to the Mylar electrode the new titanium electrode showed twice as much  $\gamma$ -flash background events whereas the amount of proton induced events<sup>3</sup> was reduced by a factor of 10. Reactions on the electrodes,



**Figure 5.** Two dimensional spectrum of anode rise time versus deposited particle energy for the down stream part of DFGIC#2 (2.8bar) using titanium electrodes. The colored lines, depicted as maximum particle rise times, are estimated from stopping ranges calculated by SRIM [11]. Events below the dashed line are selected for a rise time cut.

such as  $(n, p)$  reactions, can be discriminated and the number of oxygen atoms in an active volume can be defined by a drift time information which corresponds to the origin<sup>3</sup> of the particle track. This information can be deduced from the start of the Cathode- and the end<sup>3</sup> of the Anode signal. A combination of drift- and rise time cut helps to reject most of the background coming from protons and  $\gamma$ -flash. The applied rise time cut is indicated in Figure 5. For the drift time  $t_D$ , events of one third of the active volume,  $\frac{1}{3}T_D^{\text{Max}} \leq t_D \leq \frac{2}{3}T_D^{\text{Max}}$ , have been selected, where  $T_D^{\text{Max}}$  is the maximum electron drift time of about 1200ns. In Figure 6 the drift- and rise time cut, applied on a two di-

mensional time-of-flight versus deposited particle energy spectrum, is shown. The time-of-flight is deduced from the start time of the Cathode signal. The largest remaining background contribution comes from the recoil of gas atoms due to elastic scattering of neutrons with the 95% Kr+5%  $\text{CO}_2$  gas mixture.



**Figure 6.** Two dimensional spectrum of the time-of-flight versus deposited particle energy for the down stream part of DFGIC#2 (2.8bar) using titanium electrodes. The colored lines are calculated from kinematics for different particle reactions.

## 4 Summary and Outlook

In order to perform the measurement of the  $^{16}\text{O}(n, \alpha)^{13}\text{C}$  reaction cross-section at the n\_TOF facility at CERN a DFGIC containing a gaseous target has been constructed at Helmholtz-Zentrum Dresden-Rossendorf. From the first detector test in November 2017 in EAR1 the properties of the  $\gamma$ -flash effecting the preamplifier could be characterized. The results of that test lead to the development of a switch device for gating the preamplifier electronics. This allowed to perform the main experiment in November 2018 for the first time at n\_TOF without any charge induction from the  $\gamma$ -flash in the CSP. Without being not blinded by the  $\gamma$ -flash any more the huge amount of neutron induced background was discovered, which prevented to identify  $(n, \alpha)$  reactions.

For this reason another measurement at nELBE, where the  $\gamma$ - and neutron induced background is much lower, has been performed in April 2019. For the first time at nELBE this measurement has been successfully performed with a digital DAQ system. The data analysis is still ongoing, but already reveals  $(n, \alpha)$  reactions. Furthermore the neutron induced background could be identified and disentangled. From the measurement at nELBE it is clear that the largest background contribution was resulting from the electrode foils.

For the experiment at the n\_TOF facility hydrogen containing aluminized Mylar electrode-foils were used, which were originally chosen to reduce the impact of the  $\gamma$ -flash. In retrospect, it turned out that this Mylar foil was the main source of the neutron induced background. For future experiments, using the DFGIC, the choice of the

<sup>3</sup>Here: particles emitted in forward direction to the beam, in the down stream part of the DFGIC#2 are considered.

material layers has to be made very carefully. A redesign of the electrode material of the current DFGIC is ongoing.

## Acknowledgements

This work has been supported by the Wolfgang Gentner Programme of the German Federal Ministry of Education and Research (grant no. 05E15CHA).

## References

- [1] C. Guerrero et al. Eur. Phys. J. A (2013) 49:27
- [2] E. Altstadt et al., Ann. Nucl. Energy **34** (2007) 36.
- [3] M.B. Chadwick et al., Nucl. Data Sheets **118** (2014) 1–25.
- [4] CERN-INTC-2015-001 / INTC-P-430.
- [5] S. Cristallo et al. The Astrophys. J., 859:105, 2018.
- [6] G. Giorginis et al. Int. Conf. on Nucl. Data for Sc. and Tech. (2007) 140.
- [7] T. Kögler et al., Phys. Proc. 47, **178** (2013).
- [8] H. G. Essel and N. Kurz. GSI Multi-Branch System - Reference Manual, Version 5.1. GSI, Planckstraße 1, D-64291 Darmstadt, Germany (2010).
- [9] R. Brun and F. Rademakers, ROOT - An Object Oriented Data Analysis Framework, Proceedings AI-HENP'96 Workshop, Lausanne, Sep. 1996, Nucl. Inst. & Meth. in Phys. Res. A **389** (1997) 81-86. See also <http://root.cern.ch/>.
- [10] J. Adamczewski-Musch et al., The Go4 Analysis Framework, Version 5 GSI, Planckstraße 1, D-64291 Darmstadt, Germany (2015).
- [11] J. Ziegler et al. – The Stopping and Range of Ions in Matter, SRIM Co., 2008.