

Towards An H^- RF Source for Future CERN Accelerator Projects

D. Kuchler^A, Th. Meinschad^A, J. Peters^B, R. Scrivens^A

^A CERN, Geneva, Switzerland

^B DESY, Hamburg, Germany

Abstract

An increase of beam intensity and brightness is essential for future upgrades of existing CERN proton accelerator facilities. A first step can be an injection of H^- ions from a new higher energy H^- linear accelerator called Linac4 into the Proton Synchrotron Booster (PSB). A second step could be the complete replacement of the PSB by a high-power linear accelerator, called SPL, injecting directly into the Proton Synchrotron (PS). Both injection scenarios require a high performance, high reliability negative hydrogen ion source. This paper will present the challenging source requirements and the two approaches to fulfil them.

Paper presented at the 11th International Symposium on the Production and Neutralization of Negative Ions and Beams 2006, September 13 – 15, Santa Fe, NM, USA

Towards An H^- RF Source for Future CERN Accelerator Projects

D. Kuchler*, Th. Meinschad*, J. Peters[†] and R. Scrivens*

*CERN, Geneva, Switzerland

[†]DESY, Hamburg, Germany

Abstract. An increase of beam intensity and brightness is essential for future upgrades of existing CERN proton accelerator facilities. A first step can be an injection of H^- ions from a new higher energy H^- linear accelerator called Linac4 into the Proton Synchrotron Booster (PSB). A second step could be the complete replacement of the PSB by a high-power linear accelerator, called SPL, injecting directly into the Proton Synchrotron (PS). Both injection scenarios require a high performance, high reliability negative hydrogen ion source. This paper will present the challenging source requirements and the two approaches to fulfill them.

Keywords: ECR H^- ion source, RF H^- ion source, Linac4, SPL

INTRODUCTION

The injection of an intense proton beam into existing and future CERN accelerator structures is limited by the performance of Linac2 and the Proton Synchrotron Booster (PSB). An H^- linear accelerator (Linac4), injecting at 160 MeV into the PSB, could replace the present proton linac (Linac2) and double the brightness and the intensity of the PSB beam [1].

TABLE 1. Required H^- ion source parameters for the different design phases of future CERN H^- linacs [2].

	<i>Phase0</i>	<i>Phase1</i>	<i>Phase2</i>
	3MeV Test Stand	Linac4	SPL
H^- current [mA]	≥ 40	80	80
pulse length [ms]	0.4	0.4	0.57/0.71 ^A
repetition rate [Hz]	2	2	50
duty factor [%]	0.08	0.08	max. 3.55
emittance [π mm mrad] ^B	0.25	0.25	0.25

The Superconducting Proton Linac (SPL) - containing an extended Linac4 (up to an end energy of 180 MeV) as its front end - allows to omit the entire PSB complex and to inject directly (at 3.5 GeV) into the Proton Synchrotron (PS) [2]. The beam quality of the proton injector chain for CERN's physics programs, including LHC operation [3] and LHC luminosity upgrades [4, 5], will therefore profit from this improvement. The

^A including beam for neutrino facility/EURISOL (EUROpean Isotope Separation On-Line)

^B 1 rms, normalized

current design [6] of the SPL (Figure 1) is based on a multi-user concept and can satisfy the needs of various present and future CERN facilities, as EURISOL [7], ISOLDE [8] and a neutrino facility [9].

All these projects require a high performance and high reliability H^- ion source. The source parameters for the different H^- linac design phases are summarized in Table 1. The 3 MeV Test Stand - the front end of Linac4 - is approved and will be operational in 2008 [10]. The Linac4 is expected to be approved at the end of 2006. The 2nd conceptual design report of the SPL project has recently been published.

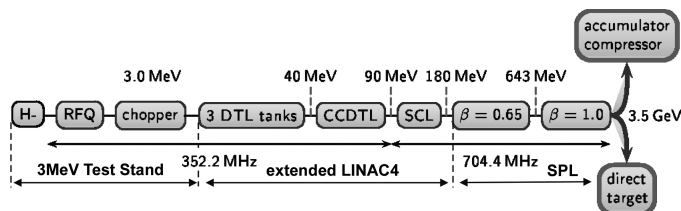

FIGURE 1. Schematic layout of the Superconducting Proton Linac (SPL). The 3 MeV Test Stand and an extended Linac4 (with an increased end energy) form the front end of the SPL [2].

TESTS OF THE 2.45 GHz ECR ANTENNA H^- ION SOURCE

Due to experience with ECR technology a development of a microwave driven H^- ion source was launched in 2002. This CERN ECR source operates at a frequency of 2.45 GHz. The highest H^- current (0.29 mA) was reached with the pure multicusp configuration (0.29 T at the magnet position inside the plasma chamber). Table 2 shows the achieved source parameters at a microwave power of 1.5 kW. Further details about this source can be found in [11, 12].

TABLE 2. Parameters of the CERN ECR H^- ion source (2.45 GHz) [11].

highest achieved H^- current [mA]	0.29
electron current [mA]	4.6
pulse length [ms]	10
repetition rate [Hz]	1
duty factor [%]	1
extraction voltage [kV]	20
plasma electrode bias [V]	25

At CEA/Saclay the introduction of a stainless steel grid, acting as a RF filter, into the plasma chamber, led to an increase of H^- current from a few μA to 1.5 mA [13]. Motivated by this improvement a grid was also installed in the CERN ECR source between the plasma electrode (PE) and the magnetic filter (Figure 2). During the CERN experiments the plasma is confined by the multicusp structure and a pair of solenoids around the plasma chamber. This magnetic structure leads to better I_{H^-}/I_{e^-} ratios compared to the pure multicusp structure, but the H^- current drops to about 0.12 mA under optimized conditions [11]. For these measurements two different grids were constructed (Figure 4). After the insertion of a grid at a certain distance d from the PE the source was always tuned to the maximum H^- current by adjusting the hydrogen

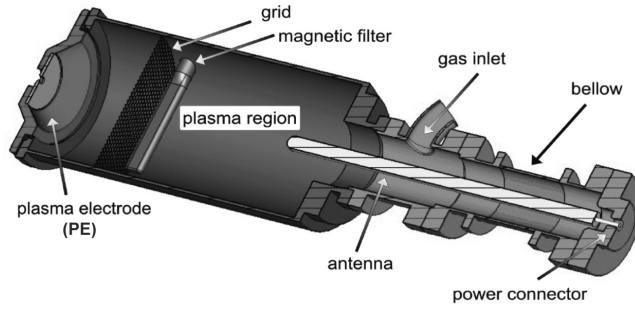

FIGURE 2. CERN H^- ECR ion source. The microwave power is coupled to the plasma by an internal adjustable antenna. The plasma chamber is divided by a magnetic filter (~ 7 mT in the middle of the two rods that are 78 mm away from the plasma electrode) [11].

flow, the position of the antenna and the solenoidal field. These optimized parameters were then kept constant during the grid measurements, whereas the plasma electrode- and the grid potential could be varied independently. For grid #1 (Figure 4, left) the PE-grid distance d could be changed between 5 to 60 mm. The grid in the extraction region led generally to smaller H^- currents. However, in a first set of measurements it could be shown that a reduction of the distance d led to an enhancement of H^- current (from 0.06 mA to 0.1 mA). At distances further away from the PE ($d > 35$ mm) the grid had no effect on the H^- current (Figure 3). Contrary to the Saclay results, the enhancement of H^- current was found at positive grid potentials (with respect to the source potential). Due to the electrical attraction close to the grid, electrons and negative ions were drawn to it. Experiments with an electrical field-free zone (same bias on the grid and the PE) in the extraction region did not lead to an H^- current increase.

The smallest feasible distance with grid #1 was about 5 mm. Thus, grid #2 (Figure 4, right) was constructed which allowed to come closer to the extraction hole. Grid #2 and

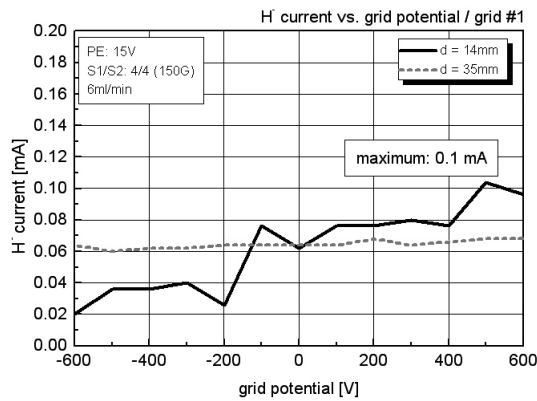

FIGURE 3. H^- current measurements at interesting distances from the PE. The error bars (in the order of 0.01 mA) are omitted in the graph. At a certain distance (~ 14 mm) from the PE an H^- current increase is measurable. The source settings are specified in the box (PE bias of 15 V; the magnetic field of the 1st and the 2nd solenoid: 15 mT at central axis; H_2 flow: 6 ml/min).

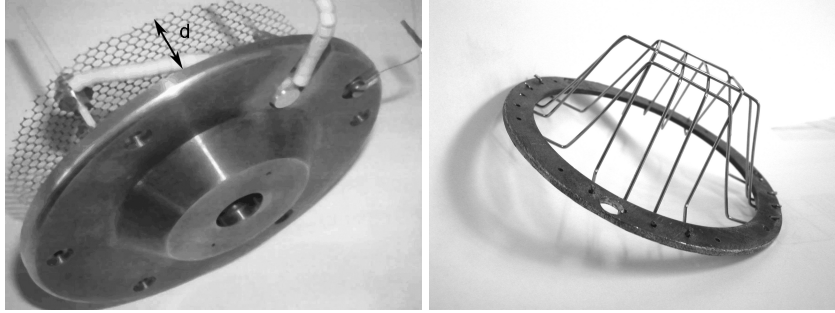

FIGURE 4. The stainless steel grid #1 (left) is attached to the copper plasma electrode. The grid is kept at constant distance by three ceramic rods, which are screwed into the PE. The grid is adjustable and the parameter d indicates the grid-PE distance. The stainless steel wires of grid #2 (right) are fixed on a copper ring. The trapezoidal shape of grid #2 makes smaller distances to the PE feasible.

a further reduction of the grid to PE distance showed no improvement, moreover the H^- current decreased at the same grid position due to insufficient RF filter capability and a drain of H^- ions from the region close to the extraction hole.

During a third set of measurements with a slightly modified grid #1 (reduction of the grid surface and some re-drilled holes) electron and H^- currents were remeasured (Figure 5). It could be shown that at a certain distance (~ 14 mm) from the PE the positively biased grid leads to an H^- current increase. For smaller distances the grid draws away the H^- ions, for longer distances the grid effect ceases. It seems that the H^- and electron distribution in this source do not have their maxima at the same distance from the PE. If the grid is closer to the maximum of the electron distribution, the extraction region becomes more the depleted of electrons than of H^- ions (Figure 5). On the other hand, if the grid is closer to the PE - respectively to the maximum of the H^- distribution - the number of H^- ions is reduced.

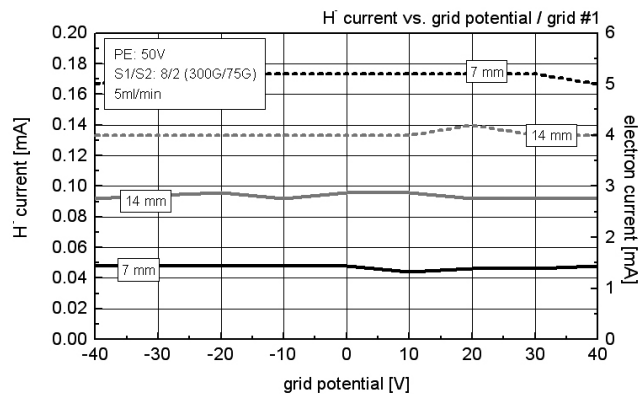

FIGURE 5. H^- and e^- (dashed lines) current measurements at two grid positions ($d = 7$ & 14 mm). A modification of grid #1 and the following retuning of the source resulted in higher H^- currents compared to the initial optimized setup (Figure 3).

PROPOSAL FOR A 2 MHZ RF DRIVEN SOURCE

The insertion of a grid led to an H^- current increase, but the values published in Table 2 could not be improved. Therefore, it became quite evident that the CERN ECR H^- ion source cannot fulfill the Linac4 requirements (see Table 1). Unfortunately, at the moment no existing H^- ion source can meet them entirely. Among all operational H^- ion sources the DESY RF source, proving its high reliability and high current capability over the past years, comes close to the requirements [16]. This RF volume source is powered by a 2 MHz RF generator, runs without cesium and has up to now a lifetime of about 25000 hours. It delivers routinely 40 mA within 0.1 ms pulses at an extraction voltage of 35 kV (see Table 3). During recent tests (emittance measurements were not included) currents of 60 mA have been reached [16]. Moreover, this source is a promising candidate for improving its performance up to the necessary requirements.

TABLE 3. Standard operation parameters of the cesium-free DESY RF H^- ion source (2 MHz) [17].

negative hydrogen current [mA]	40
electron current [A]	1.2 - 2
pulse length [ms]	0.1
repetition rate [Hz]	5
duty cycle [%]	0.05
extraction voltage [kV]	35
emittance [π mm mrad] ^A	0.25 for 38mA [18]

As a result of the European HP-NIS collaboration (contract number: HPRI-CT-2001-50021) CERN has initiated an official collaboration with DESY. This collaboration allows CERN to build a version of the DESY-HERA source and ensures the availability of an operational H^- source until the end of 2007. In the following, it will be presented, how we intend to reach the challenging Linac4 requirements.

CERN Source Concept

The basic idea is to power the components, that are held at 35 kV in the DESY source, from a 95kV high voltage platform. The source equipment, that is kept at ground potential at DESY, floats on an intermediate 60 kV HV platform - except the 2 MHz RF generator^B and the vacuum pumps. In this way only the HV power supply on the 60 kV platform (see Figure 6) must be dimensioned for higher power operation (35 kV, around 4 A/pulse). After the extraction and the removal of the electrons by a set of permanent magnets the H^- ions are post-accelerated with a diode gap.

^A 90% rms, normalized

^B specs: 2 ± 0.2 MHz, 100 kW peak power, pulsed up to 1 ms, max. repetition rate 50 Hz, pulse-to-pulse stability $\sim 1\%$, pulse stability (during pulse) $\sim 1\%$, single frequency operation

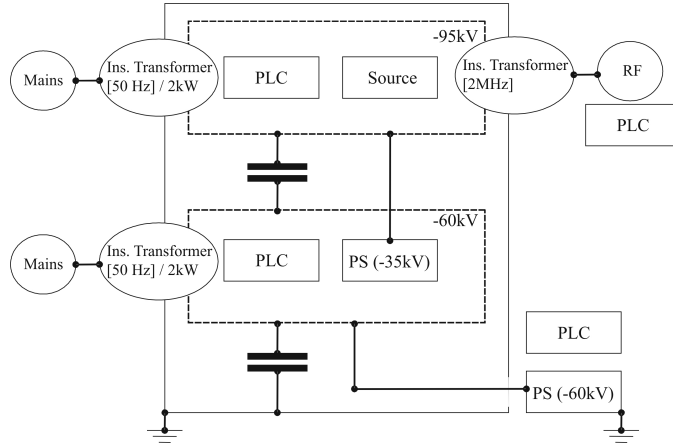

FIGURE 6. Basic schematic electrical circuit for the two HV platforms placed in a HV cage (PS - HV power supplies). The power is transferred to the platforms via two 50 Hz and one 2 MHz isolation transformers. The passive components of the source (held at 60 kV) are not drafted. A PLC [14] system controls the source.

Post-Acceleration & Low Energy Beam Transfer (LEBT)

In the present design the Linac4 LEBT consists of two large diameter (110 mm) solenoids with a diagnostic box in-between. The total length of the LEBT is 1.8 m. Simulations are made with a linear beam compensation model, with a compensation fraction of 90%. These show an emittance growth in the solenoids due to the high divergence of the beam for the source and the post-acceleration system (PAS) (Figure 7). Therefore the PAS & LEBT emittance growth are strongly coupled and a compromise must be sought. Assuming a uniform beam density in horizontal and vertical space PAS & LEBT deliver a minimum emittance growth of 13% (PAS) and 7% (LEBT) with the present design [15]. The emittance is optimized with a short PAS-solenoid distance and the space charge compensation will be optimized with gas injection.

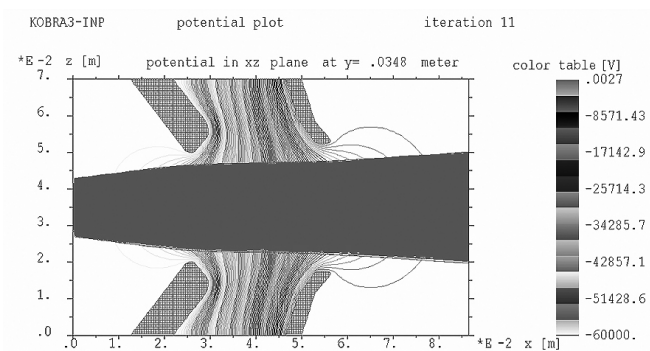

FIGURE 7. Optimized two lens post-acceleration system: KOBRA [19] plot of a uniform H^- beam extracted through the field shaping electrode (left, 30 mm aperture) and the ground electrode (right). The distance between the electrodes is 20 mm [15].

Mechanical Issues

The CERN design is based on various points. In order to keep the changes to the DESY source as small as possible, the inner DESY source bucket, with its 35 kV insulation, is inserted inside a second, main insulator ($l = 200$ mm, $D_{outer} = 420$ mm, wall thickness = 30 mm), which in turn is fixed to the vacuum pumping box (Figure 8). The vacuum box with the pumping flanges and the vacuum gauges are outside the HV cage at ground potential. In this way the pumps can be kept away from the 60 kV HV platform. Two 500 l/s turbo molecular pumps should be sufficient to provide a pressure of around 10^{-5} mbar close to the extraction region.

In order to limit the emittance growth in the LEBT, the distance of the ground electrode to the 1st LEBT solenoid must not exceed a certain value. For the foreseen Linac3 solenoids this value is around 137 mm. Putting the DESY bucket into the main insulator the required proximity to the solenoid is feasible keeping the length of the ceramic at a safe value. The field shaping electrode of the PAS is fixed on the DESY bucket (Figure 9), the ground electrode is attached inside the vacuum box. The exchange and the adjustment of these electrodes is possible due to the fixation of the DESY bucket to a linear transfer system in the HV cage.

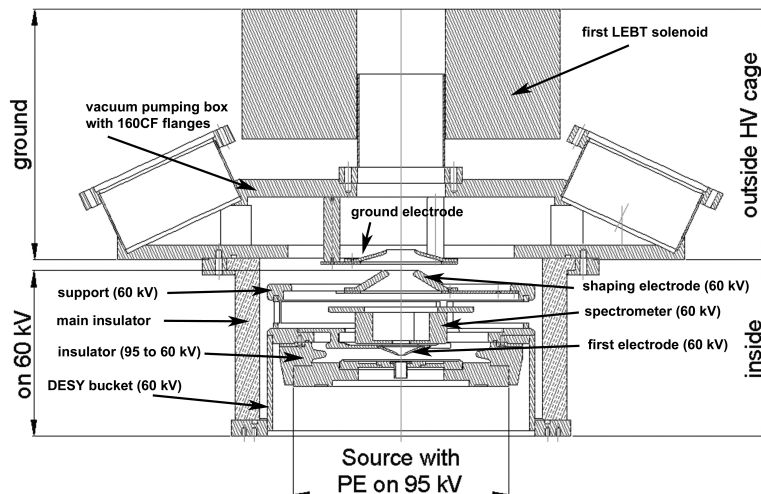

FIGURE 8. Horizontal projection of the CERN H^- source. Except for the biasable plasma electrode (PE) all RF source components, that are held at 95 kV (DESY inner bucket: plasma chamber, RF coil etc.) are omitted in this drawing. The DESY bucket can be moved out of the main insulation cylinder.

Dynamical Compensation and Radio Frequency Issues

During the beam pulse current is drawn from the storage capacitors of both HV power supplies resulting in a voltage drop. One can compensate for this voltage drop by increasing the storage capacitors for a given drawn current, in order to keep the energy spread from the source within acceptable margins (passive compensation). Generally energy spread leads to transverse emittance growth in the LEBT due to chromatic effects in the solenoids and to higher longitudinal emittances at the RFQ output (spoiled shaping

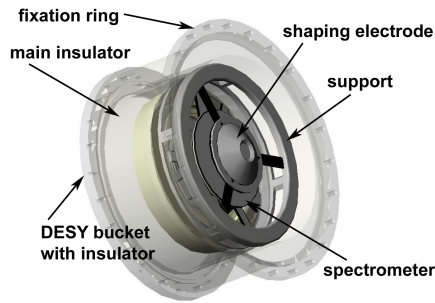

FIGURE 9. Transparent view of the source parts (kept at 60kV) inside the modified DESY bucket. The shaping electrode is fixed to a support which itself is attached to the DESY bucket (see also Figure 8). The inner ceramic provides the insulation from 95 kV down to 60 kV.

in the RFQ). The Linac4 requires an energy spread smaller than 1% [20]. A design current of 100 mA H^- (respectively 3.3 A of electron current) and two storage capacitors of 2.6 μF and 200 nF result in an calculated voltage drop of 0.720 V. This energy spread is acceptable, but in case of sparking the energy stored in these high value capacitors might pose a problem. Therefore, an active compensation scheme (similar to the one of Linac2 [21]) has been developed (Figure 10), which allows a reduction of the storage capacitors and an energy spread close to zero.

The H^- current of the DESY source shows a strong dependance on the driver frequency [16]. The optimal working frequency is around 2 MHz. The RF power is inductively coupled to the plasma by a RF copper coil ($L \sim 0.4 \mu H$, 0.2Ω at 2 MHz). The generator operates at ground potential, whereas the source runs at the 95 kV platform. The HV isolation is provided by a RF isolation transformer and a capacitive network, which also matches the impedance of the RF generator to that of the RF coil.

Conclusions and Expectations

A conceptional design of the CERN RF H^- ion source has been made. The implementation of the technical drawings from DESY should start during October 2006.

For a 40 mA H^- beam (nominal current for the 3MeV Test Stand) simulations indicate an emittance growth due to the PAS. Higher beam currents generally lead to higher source emittances. Due to the high current requirement of Linac4 additional emittance growth must be expected.

As a first step, H^- current will be attempted to be increased by coupling a more powerful RF generator to the source. If this fails, a cesiation of the source is foreseen.

ACKNOWLEDGMENTS

The authors would like to thank C. Mastrostefano and M. O'Neil for the support in mechanical and electrical issues. Also we thank M. Paoluzzi for his commitment in RF issues.

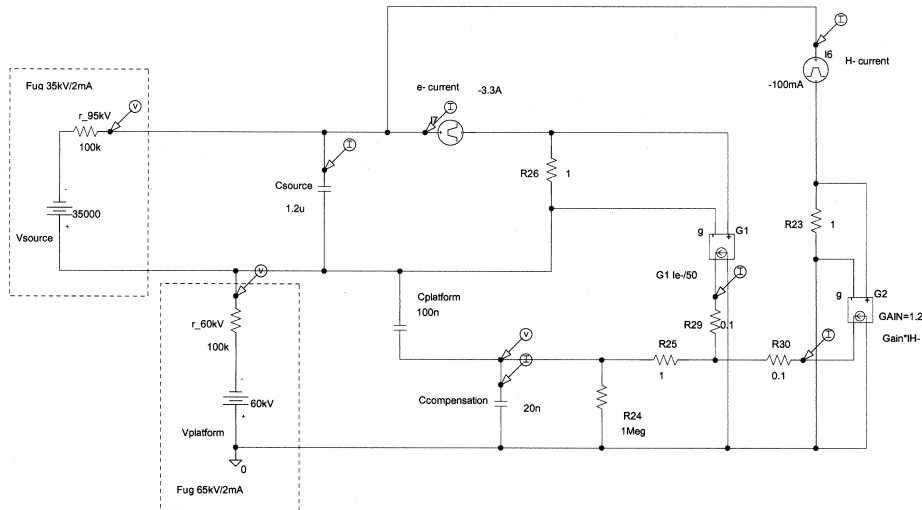

FIGURE 10. The active compensation works by injecting current into a series capacitor. The voltage on this capacitor rises then at a rate equal to the rate of the voltage drop across the other two capacitors. The compensation current is proportional to the electron and H^- currents where the exact gain is dependent upon the main storage capacitor values.

REFERENCES

1. M. Martini and C.R. Prior: High intensity and high density charge-exchange injection studies into the CERN PS booster EPAC, CERN-AB-2004-069 (2004).
2. The SPL study group: Conceptional Design Report II, CERN-2006-006, Geneva (2006).
3. LHC Design Report: CERN-2004-003, Geneva (2004).
4. M. Benedikt, K. Cornelis, R. Garoby, E. Metral, F. Ruggiero, M. Vretenar: Report on the High Intensity Protons Working Group, CERN-AB-2004-022 OP/RF (2004).
5. M. Benedikt et al.: Preliminary accelerator plans for maximizing the LHC integrated luminosity (PAF report) (2006).
6. F. Gerigk et al.: The SPL (II) at CERN, a Superconducting 3.5 GeV H^- Linac, to be published at LINAC06 (2006).
7. <http://eurisol.org>
8. <http://isolde.web.cern.ch/ISOLDE/>
9. P. Gruber et al.: The study of a European neutrino facility complex, CERN-NUFACT-NOTE 112 (2002).
10. C. Rossi et al.: The SPL front end: A 3 MeV H^- Test Stand at CERN, Proc. LINAC04 (2004).
11. Th. Steiner: PHD Thesis - TU Vienna (2005).
12. Ch. Hill et al.: H^- Source Developments at CERN, Proc. PNNIB (2004).
13. R. Gobin et al.: Status of the Negative Hydrogen Ion Test Stand at CEA Saclay, Proc. PNNIB (2004).
14. Programmable Logical Controller: Siemens S7/300.
15. R. Scrivens et al.: Proposal for Post Acceleration, Matching and Measuring the H^- Ion Beam for CERN's Linac4, to be presented at LINAC06 (2006).
16. J. Peters: The HERA RF-Volume Source, PAC05 (2005).
17. J. Peters: Internal versus external Rf coupling into a volume source, Proceedings of EPAC02 (2002).
18. J. Peters: The New HERA H^- RF Volume Source, Proceedings of LINAC02 (2002).
19. P. Spaetke: Sophisticated computer simulation of ion beam extraction for different types of plasma generators RSI 75 (5) p1643 (2004).
20. A. Lombardi, CERN, private communication (2005).
21. C.E. Hill, M. O'Neil: The High Voltage System for the High Intensity CERN Proton Source, LINAC96 (1996).