

XXI. NONLINEAR CIRCUITS

Prof. E. A. Guillemin
Prof. S. J. Mason

Prof. H. J. Zimmermann
J. Gross

T. E. Stern
R. D. Thornton

RESEARCH OBJECTIVES

This research is aimed at a variety of problems, including piecewise-linear function generation for analog computation, analysis of oscillations in electronic systems, and the development of useful circuit models for nonlinear devices. The general objectives of this group are: to gain a better understanding of nonlinear circuit theory and to further the advancement of methods of nonlinear analysis.

S. J. Mason

A. PIECEWISE-LINEAR TRANSFER FUNCTION SYNTHESIS

Some typical piecewise-linear unit functions that form the basis for transfer function synthesis for one and two variables were discussed in the Quarterly Progress Report of July 15, 1955. It was stated that generalization of the synthesis procedure of functions of more than two independent variables is fairly straightforward. This generalization is presented here.

The problem is as follows: Given $y = f(x_1, x_2, \dots, x_n)$, an arbitrary function of n variables tabulated at the vertices of a hypercubical grid of tabulation in the n -dimensional independent variable space; construct a network containing linear elements and ideal diodes only that will produce a piecewise-linear and continuous function taking on the prescribed values at the points of tabulation.

The crux of the problem is the development of a scheme for interpolating continuously between the given points with a piecewise-linear function. Ordinary linear interpolation is a satisfactory method for functions of one variable. For two variables, the logical extension of linear interpolation, bilinear interpolation, produces a function of the form

$$y = a_0 + a_1x_1 + a_2x_2 + a_{12}x_1x_2$$

Because of the product term, this function is clearly not piecewise-linear and therefore is inadmissible, since it cannot be synthesized by using the components that we have postulated. Extension to more variables produces still more product terms.

In the Quarterly Progress Report of July 15, 1954, a way out of this dilemma for functions of two variables was indicated. This method consists of dividing each square of tabulation in the independent-variable plane into two triangles by drawing one diagonal of the square and then, in defining a function that is linear over each triangle and that takes on the prescribed values at the points of tabulation. This is a valid piecewise-linear interpolation function. Figure XXI-1 shows a portion of the x_1 - x_2 plane divided in this manner by drawing the lines $x_1 - x_2 + m\Delta = 0$ (where Δ is the interval of tabulation and $m = 0, 1, -1, 2, -2, \dots$).

(XXI. NONLINEAR CIRCUITS)

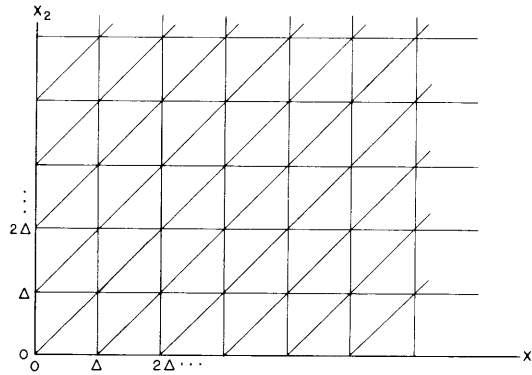

Fig. XXI-1. Simplicial subdivision of x_1 - x_2 plane.

By generalizing this procedure to an n -dimensional tabulation, each n -dimensional hypercube in the grid of tabulation can be divided into n -simplices by passing all $n - 1$ dimensional hyperplanes of the form

$$\begin{aligned}x_i - x_j + m\Delta &= 0 & i &\neq j \\ & & i &= 1, 2, \dots, n \\ & & j &= 1, 2, \dots, n \\ & & m &= 0, 1, 2, \dots\end{aligned}$$

(An n -simplex may be defined as the least convex set containing $n + 1$ linearly independent points. For example, for $n = 1$ it is a line segment including its end points; for $n = 2$, a triangle; for $n = 3$, a tetrahedron, and so on.) It can be shown that this mode of subdivision of the independent variable space divides each n -cube into $n!$ simplices that are nonintersecting except for their bounding surfaces and whose vertices correspond to the points of tabulation. Figure XXI-1 indicates such a subdivision for $n = 2$, and Fig. XXI-2 shows the subdivision of one cube of the independent variable space for $n = 3$. (Note that it is divided into $n! = 6$ tetrahedra, which are slightly separated from each other for purposes of illustration.) Although other methods of subdivision are possible, this particular one was chosen because of its simplicity.

Now a function can be defined that is linear over each simplex and takes on the prescribed values at the points of tabulation (since a linear function of n -variables is uniquely determined by the values it assumes at $n + 1$ linearly independent points in the independent variable space). This definition produces a piecewise-linear function that has the desired properties.

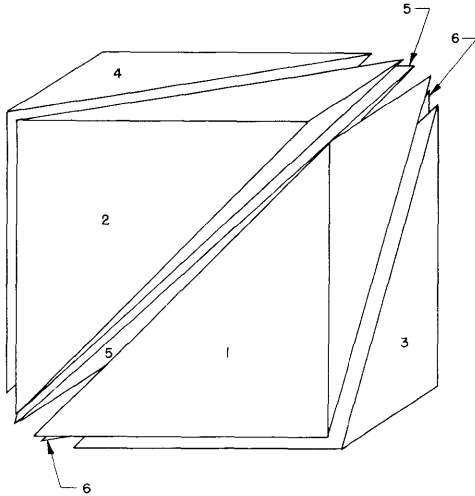

Fig. XXI-2. Simplicial subdivision of cube.

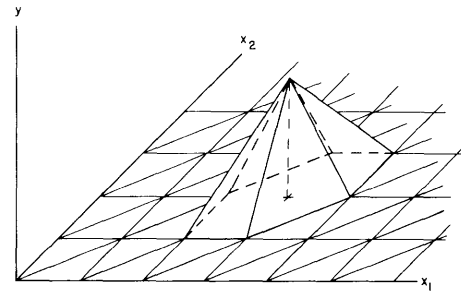

Fig. XXI-3. Universal unit pyramid.

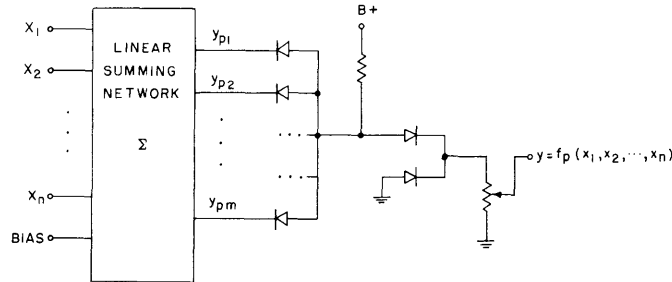

Fig. XXI-4. Universal unit pyramid network.

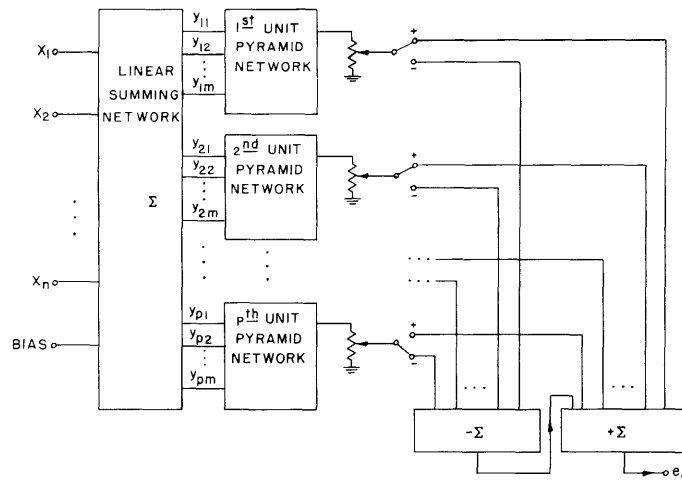

Fig. XXI-5. Generator of $e_o = f(x_1, x_2, \dots, x_n)$.

(XXI. NONLINEAR CIRCUITS)

1. Realization of the Function

The function defined above can be generated as the superposition of a number of simpler functions which will be called "universal unit pyramid" functions. The n -dimensional unit pyramid function centered over the tabulated point p will be denoted by $y = f_p(x_1, x_2, \dots, x_n)$; it is defined as follows:

1. f_p is linear over each simplex in the independent variable space (according to the definition of the simplices given above).
2. $f_p = 1$ at the point p (its apex or center).
3. $f_p = 0$ at every other vertex of the grid of tabulation.

A function of this kind is piecewise-linear and continuous and can be written in the form

$$y = f_p(x_1, x_2, \dots, x_n) = [(y_{p1}, y_{p2}, \dots, y_{pm}) \phi^-, 0] \phi^+ \quad m = (n+1)!$$

where each y_{pj} is a linear function of the form

$$y_{pj} = a_{pjo} + a_{pj1}x_1 + a_{pj2}x_2 + \dots + a_{pjn}x_n$$

The symbolism was explained in the Quarterly Progress Report of July 15, 1954. Figure XXI-3 shows the surface formed by this function for $n = 2$; Fig. XXI-4 shows the form of a network for realizing the function for any n . The potentiometer permits scaling of the function with a positive constant less than one.

A little reflection should convince the reader that summation of a number of functions of this kind suitably scaled (one centered over each point in the grid of tabulation) will produce any arbitrary function of n -variables satisfying the conditions stated initially.

Figure XXI-5 is a block diagram of such a general function generator. The value of the function at any tabulated point is "programed" by setting the potentiometer controlling the scale factor of the unit function centered over that point. The switches provide for negative coefficients.

T. E. Stern

B. TUNED CIRCUITS CONTAINING "UNSUITABLE" NEGATIVE RESISTANCE

The free motions of n^{th} -order linear dissipative systems (i. e., systems containing n independent energy storage elements) are continuous functions of time which have continuous first $n - 1$ derivatives. Some nonlinear systems, on the contrary, have discontinuous free motions. A second-order nonlinear system having a stable, discontinuous periodic motion is described in reference 1. In this report a second-order system having unstable discontinuous motion is analyzed.

A current-controlled negative resistance connected to a series-tuned circuit (or its

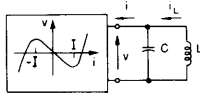

Fig. XXI-6. Current-controlled negative resistance and parallel-tuned circuit.

dual, a voltage-controlled negative conductance connected to a parallel-tuned circuit) is "suitable" for producing stable periodic oscillations, which are almost-harmonic in the control-variable in the case of a low-loss tuned circuit. We treat the "unsuitable" connection of a current-controlled negative resistance and a parallel-tuned circuit (Fig. XXI-6), or its dual. This yields a bistable circuit in which the relaxation oscillations, which appear in a circuit containing the arc and capacitor, have become unstable.

In order to describe the circuit by a system of differential equations containing single-valued functions only, we choose as variables i, i_L . These obey

$$\left. \begin{aligned} L \frac{di_L}{dt} &= -v \\ C \frac{dv}{dt} &= i_L - i \end{aligned} \right\} \quad (1)$$

The negative resistance is characterized by

$$v = r I f\left(\frac{i}{I}\right) \quad (2)$$

where f is single-valued, bounded, and continuous for finite i ; $f'\left(\frac{i}{I}\right) \leq 0$ for $|i| \leq I$; and $f''\left(\frac{i}{I}\right) \neq 0$ for $|i| > I$. Normalizing

$$x = \frac{i}{I}, \quad y = \frac{i_L}{I}$$

we rewrite Eq. 1

$$\left. \begin{aligned} \frac{dy}{dt} &= -\frac{r}{L} f(x) \\ \frac{dx}{dt} &= \frac{y - x}{rC f'(x)} \end{aligned} \right\} \quad (3)$$

Eliminating y we obtain an equation of motion

$$f'(x) \ddot{x} + \left[f''(x) \dot{x} + \frac{1}{rC} \right] \dot{x} + \frac{f(x)}{LC} = 0 \quad (4)$$

which involves single-valued functions only, but is highly nonlinear.

As a starting point for our qualitative analysis we eliminate the time from Eq. 3,

(XXI. NONLINEAR CIRCUITS)

and obtain a first-order differential equation describing the trajectories of all possible motions in the phase plane x, y :

$$\frac{dy}{dx} = -Q^2 \frac{f(x) f'(x)}{y - x} \quad (5)$$

where $Q = r \left(\frac{C}{L} \right)^{1/2}$. For simplicity, we choose the usual cubic characteristic:

$$f(x) = -x \left(1 - \frac{1}{3} x^2 \right) \quad (6)$$

with $f'(x) = -(1 - x^2)$ (see Fig. XXI-7).

The phase portrait is characterized by the singular points of Eq. 3, where $dy/dt = dx/dt = 0$. These points, $P_i(x_i, y_i)$, occur for $f(x_i) = 0$, $y_i = x_i$: $P_1(0)$ is an unstable node for $Q < 1/2$, or an unstable focus for $Q > 1/2$; $P_2(\sqrt{3}, \sqrt{3})$, $P_2'(-\sqrt{3}, -\sqrt{3})$ is a stable node for $Q < 1/4$, or a stable focus for $Q > 1/4$. At these singular points the motion (Eq. 3) is determined, the trajectory (Eq. 5) is indeterminate.

The lines $x = \pm 1$, $y \neq x$ are loci of critical points, at which the system of Eqs. 3 ceases to determine the motion uniquely: as $|x| \rightarrow 1$, $|\dot{x}| \rightarrow \infty$ for any $y \neq x$. This means that when $|x| \rightarrow 1$, a discontinuous jump in x occurs toward another finite point in the x, y plane. The end point of this jump cannot be determined from the system of Eqs. 3, but is uniquely determined by the added "jump condition," which, on the basis of continuity of stored energy in any physical storage element, requires that $v[\sim f(x)]$ and $i_L[\sim y]$ be continuous during the jump. Thus a point $(\pm 1, y)$, $y \lesssim \pm 1$, is transformed by the jump into the point $(\mp 2; y)$. The points $P_3(1, 1)$, $P_3'(-1, -1)$ are neither singular nor critical points; paths passing through these points have a discontinuity in direction.

With these features of the phase portrait in mind, we have drawn some trajectories (by means of isoclines) for $Q = 1$, Fig. XXI-8, and $Q = 0.1$, Fig. XXI-9. In Fig. XXI-8 we distinguish two sets of trajectories starting with $x(0) > 1$. (Motions starting with

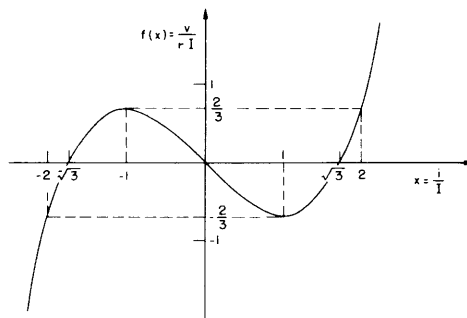

Fig. XXI-7. Analytical negative resistance characteristic.

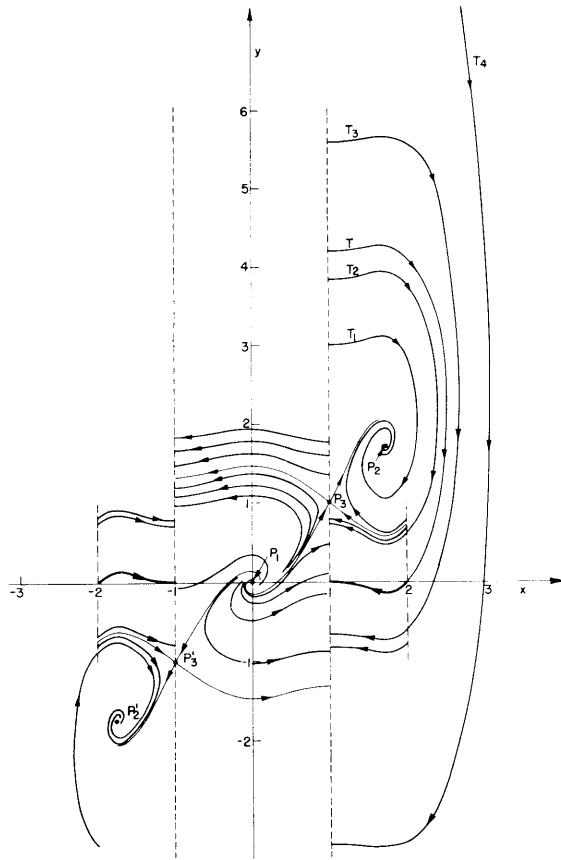

Fig. XXI-8. Phase portrait; $Q = 1$.

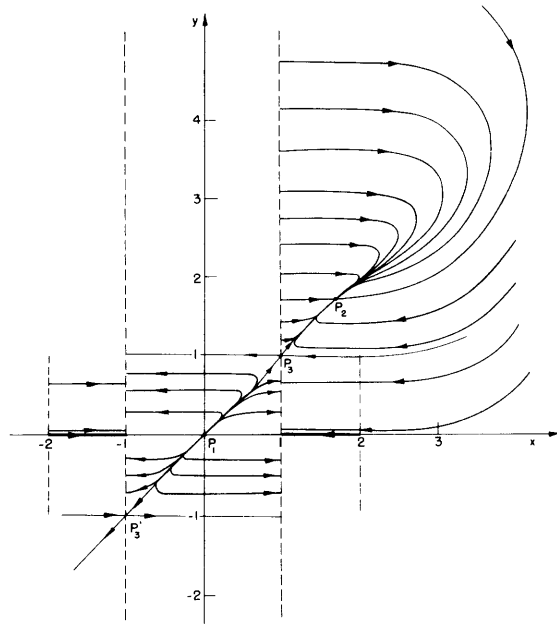

Fig. XXI-9. Phase portrait; $Q = 0.1$.

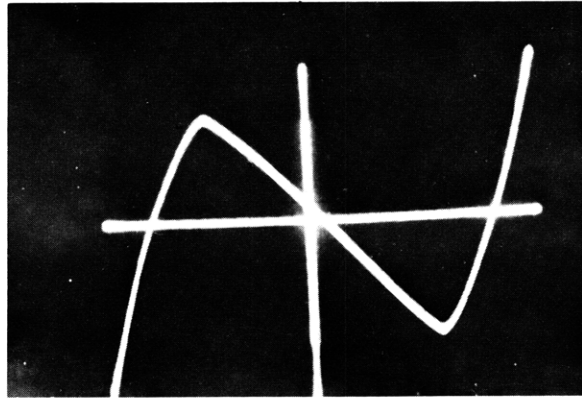
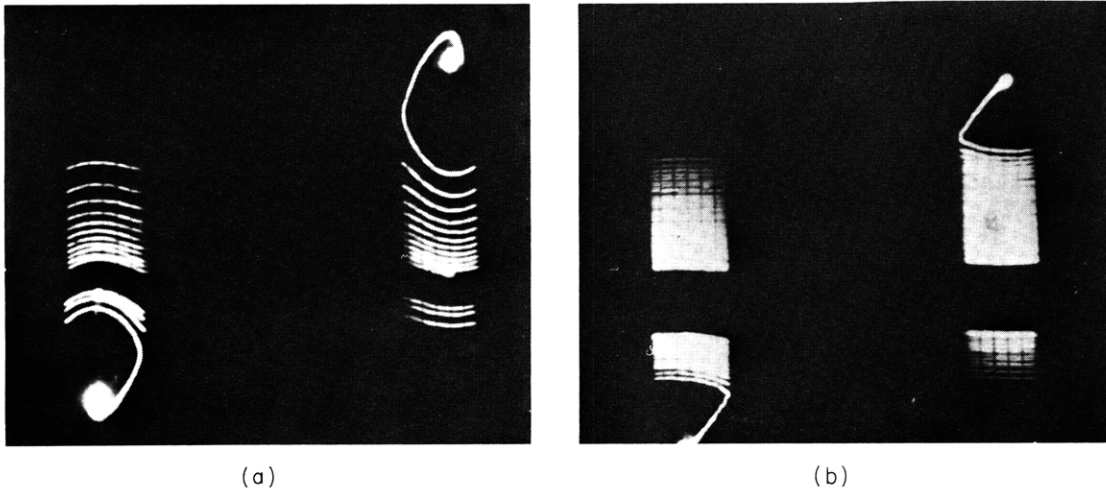

Fig. XXI-10. Experimental negative resistance characteristic.

Fig. XXI-11. i, i_L -plane: (a) $Q = 0.85$; (b) $Q = 0.31$.

$|x(0)| < 1$ do not differ from those described below, once the representative point has jumped out of the region $|x| < 1$.) One set contains paths like T_1 or T_2 , which approach P_2 continuously or by successive discontinuous "cycles"; the other contains paths like T_3 or T_4 , which approach P_2' by successive "cycles." It follows that a discontinuous limit cycle of small y -variation, with $1 \leq |x| \leq 2$, exists. The trajectory T leading into it divides the region $x > 1$ in two parts: any motion starting inside T tends toward P_2 as $t \rightarrow \infty$, while a motion starting outside of T tends toward P_2' or P_2 . Therefore the limit cycle is unstable (since a slight departure of the representative point from the limit cycle tends to carry the point farther away from it and causes it to end up at P_2 or P_2'), and the relaxation oscillation corresponding to it is physically nonexistent. There

are no other limit cycles (continuous or not) in the whole x, y plane.

We conclude that the circuit of Fig. XXI-6, with $Q = 1$, has no stable periodic oscillations and that for $t \rightarrow \infty$ it tends to either of the two stable states of equilibrium with $v = 0$.

The same holds true for $Q \ll 1$, as inspection of Fig. XXI-9 reveals. A proof for the instability of the limit cycle in this case has been given for a piecewise-linear negative resistance characteristic. The conclusion is unaffected by the particular shape of the negative resistance characteristic; it remains valid also if incidental damping of the tuned circuit is taken into account, or if pertinent small stray storage parameters are included in the analysis (in which case the jumps are replaced by rapid, continuous motions).

Thus, in general, the "unsuitable" connection of negative resistance and tuned circuit results in a bistable circuit, where no sustained oscillation is possible.

Experimental records of relevant portions of the phase portrait that support this conclusion were obtained with the negative resistance characteristic of Fig. XXI-10 and are shown in Figs. XXI-11a and b.

J. Gross

References

1. A. A. Andronov and C. E. Chaikin, *Theory of Oscillations* (Princeton University Press, 1949), Ch. VII.