

GG/mcg/05.12.2006

SIXTH FRAMEWORK PROGRAMME
Research Infrastructures Action



**Report of the 2006 CERN contributions
to the EU co-funded Activities in FP6**

by

**T.Boutboul, G.Guignard (editor), M.Lindroos, A.Lombardi, R.Losito,
M.Maitrel, L.Oberli, U.Raich, K.Riisager, L.Rinolfi, C.Rossi, C.Saitta,
W.Scandale, D.Schulte, M.Vretenar, C.Wyss (co-editor), F.Zimmermann**

Project activities in which CERN participates:

- | | |
|--|------|
| 1. CARE Integrated Infrastructure Initiative (G.Guignard, C.Wyss) | |
| 1.1 ELAN Network (D.Schulte, G.Guignard) | p.3 |
| 1.2 BENE Network (M.Lindroos) | p.5 |
| 1.3 HHH Network (W.Scandale, F.Zimmermann) | p.7 |
| 1.4 PHIN Joint Research (R.Losito, L.Rinolfi) | p.12 |
| 1.5 HIPPI Joint Research (M.Vretenar, A.Lombardi) | p.16 |
| 1.6 NED Joint Research (L.Oberli, T.Boutboul) | p.20 |
| 2. DIRAC Secondary-Beams Design Study (U.Raich, C.Rossi) | p.23 |
| 3. EURISOL Design Study (M.Lindroos, K.Riisager) | p.26 |
| 4. EURONS I3 Project (K.Riisager, M.Lindroos) | p.32 |
| 5. EUROTeV Design Study (D.Schulte, G.Guignard) | p.36 |
| 6. Financial report (M.Maitrel, C.Saitta) | p.42 |

1. CARE Integrated Infrastructure Initiative

1.1 CARE ELAN Network Activities

1/ INTRODUCTION

The objective of ELAN is to foster the development of future electron-positron colliders by providing communication platform. It focuses on the normal and superconducting acceleration techniques, on plasma acceleration on instrumentation and accelerator physics. The lion share of the latter work is actually performed within the framework of EUROTeV. The emphasis of ELAN has thus been moved toward the acceleration techniques, which are not covered in EUROTeV. CERN is responsible for leading the workpackages on normal conducting acceleration (WP1) and the one on beam dynamics (WP3).

2/ MEETINGS

ILC LET Workshop, CERN (CERN, February 8-11, 2006)

To review the status of the ILC beam physics studies and foster information exchange with the international collaborators. This workshop on low emittance transport (LET) has been organized by CERN in collaboration with EUROTeV.

European Particle Accelerator Conference (Edinburgh, UK, June 26-30, 2006)

During the conference many papers concerned linear colliders. CERN published a number of papers on CLIC R&D and on topics common to CLIC and ILC-design studies.

Workshop POSIPOL on polarized positron source based on laser Compton back scattering (CERN, April 26-28, 2006)

The meeting aims at coordinating R&D efforts towards a complete design, including optical layout, beam dynamics, laser, optical cavities and feedback.

<http://posipol2006.web.cern.ch/posipol2006/Purpose.html>

ILC School in Sokenday, Japan (May 19-27 2006)

The school has been supported by ELAN via sending a CERN staff as lecturer.

Electron Accelerator R&D for Energy Frontier (LAL, Orsay, May 15-17, 2006)

The meeting supported in parallel the following international workshops:

- CARE/ELAN workshop
- EUROTeV workshop
- EuroLEAP (European Laser Electron Acceleration in Plasma) Kickoff meeting

Contribution to ELAN parallel sessions:

WP1 (normal conducting accelerating technologies) session on vibration stabilization to review the progress done on impact of acoustic noise on a quadrupole mockup, active feedback loop studies, site characterization, rapid alignment survey and laser-based final focus stabilization.

WP3 (beam dynamics) had a combined session with WP4 (diagnostics) reviewing topics of common interest.

Contribution (talks) in plenary sessions

- Progress and plans on warm cavity technology, S.Calatroni
- Summary of the workshop on polarized positron source based on Compton back scattering, L.Rinolfi
- Achievements and plans for Instrumentation and Beam Dynamics, D.Schulte

Workshop HG2006 on High-Gradient RF (CERN, September 25-27, 2006)

The workshop dealt with experimental results, theory, computation and technology for high-gradient RF, high-power specific phenomena and collaboration reports or projects.

3/ PUBLICATIONS

The ELAN-Documents are kept in :

<http://esgard.lal.in2p3.fr/Project/Activities/Current/Networking/N2/ELAN/index.php>

List of reports with CERN authors in CARE/ELAN

Reports	Title	Authors
CARE-Report-06-006-ELAN	Annual Report of the ELAN Collaboration	F. Richard, D. Schulte
CARE-Conf-06-001-ELAN	CLIC polarized positron source based on laser compton scattering	F. Zimmermann et al.
CARE/ELAN document-2006-006	CLIC Polarized Positron Source Based on Laser Compton Scattering	F. Zimmermann et al.
CARE-Note-2006-010-ELAN	Report on the 2005 CTF3 collaboration meeting. Status of CTF3 at 2005's end	G. Geschonke
CARE/ELAN Document-2006-11	Progress in 2006 of ELAN-BDYN and INSTR	D. Schulte, G. Blair
CARE/ELAN Document-2006-10	Beam-beam interaction in the ILC. Lecture given at the first ILC School	D. Schulte
CARE/ELAN document-2006-014	Summary on the POSIPOL workshop for Linear Colliders ILC and CLIC	L. Rinolfi
CARE/ELAN document-2006-015	Progress and Plans on Warm Cavity Technology	S. Calatroni

4/ ACTIVITIES

The main activities of ELAN are to provide support for meetings. They are thus commented in the list of meetings above. They often include direct contributions from the CERN participants. An important part of these contributions originates from the work on CTF3 and high-gradient cavities. The CTF3 collaboration meeting took place in November with discussions and talks on operation results, high RF power, diagnostics, delay loop, combiner ring, CLEX (CLIC Experimental area) and its beam lines, photo-injectors and hardware issues.

5/ ACHIEVEMENTS

The main objectives of the Working Groups WP1 and WP3 were fulfilled. The review of the warm cavity results was delayed till May (talk in Orsay meeting) and documented via EPAC conference papers (CLIC Notes 677-678-680). WP1 delivered a work-plan and supported the CTF3 collaboration meeting. The report on the latter was published at mid-2006 (see document-2006-009). WP3 organised an international workshop on low emittance preservation. It also supported the ILC school by providing a lecturer on the beam-beam interaction in linear colliders.

List of deliverables achieved in 2005 with CERN participation.

Deliverable/ Milestone	Deliverable/Milestone Name	Work- package No	Planned (months)	Achieved (months)
ID	Reports on topical NC LC issues	1	27	30
ID	Proceedings of CTF3 collaboration	1	24	30

For the coming year it is planned to support the workshops for the global effort on the ILC. A review report on the progress made on the high-gradient cavity development activities is foreseen for the middle of the year. Also the CTF3 collaboration meeting initially planned for Autumn 2006 will be held at the beginning of 2007.

1.2 CARE BENE Network Activities

1/ INTRODUCTION

The BENE network aims at co-ordinating and integrating the activities of the accelerator and particle physics communities that are giving or promise contributions to the realization of upgraded and/or new European neutrino facilities of unprecedented performance. The final objectives are 1) recommend the optimal road map from the present infrastructure to the most rewarding future facilities, including conventional neutrino Superbeams, Neutrino Factories and Betabeams 2) assemble a coherent community capable to sustain the long term program of R&D, the technical realization and the scientific exploitation.

During 2006, CERN was participating in

- NUFACT06 which is the main workshop for beam based neutrino physics world wide
- International Scoping Study (ISS) of a future Neutrino Factory and super-beam facility
- workshops and meetings dealing with matters related to the preparation of a future beta-beam facility
- specialized workshops related to targets for high power facilities
- Meetings for the MERIT (Mercury Intense Target) experiment (nTOF11)

2/ MEETINGS

The Open meeting of the CERN Council strategy group in Paris, 31 January 2006

Participant: Mats Lindroos

Beta-beam meeting, Imperial College, London, 5 April 2006

Participant: Mats Lindroos

Open Meeting of the BENE Steering Group, CERN, July 4-5 2006

Contributions: Status in the Betàbeam sector (M. Lindroos)
 Initiative in the Betàbeam sector (M. Lindroos)

ECFA/BENE Day and the 3rd ISS/BENE meeting at Rutherford labs, 24-28 April 2006

Contributions: Initiative in the Betàbeam sector (M. Lindroos)
 Beta-beam status and prospects (M. Lindroos)
 SPL-based Proton Driver for ν -Facilities at CERN: Updated Description (R. Garoby)

The 4th ISS meeting and NUFACT 06, Irvine University, USA, 21-30 August 2006

Participants: seven from CERN with M. Lindroos paid by BENE.
Contributions: eleven from CERN of which one was given by the BENE financed participant:
A Low-Energy Accumulator and Cooling Ring for the Betabeam (M. Lindroos)

The NUFACT06 summer school, UCLA and Irvine University, USA, 15-23 August 2006

Contributions: Accelerator Physics and Primary Beams, courses I and II (M. Lindroos)
 Beta-beams, courses I and II (M. Lindroos)

The 5th ISS meeting, CERN, 22-24 September 2006

Participants: J.Letry
Contributions: Target: status issues and plans by J.Letry

3/ PUBLICATIONS

List of reports with CERN authors in CARE/BENE

Title	Authors and Labs
Neutrino physics, beta beams: The Beta-beam within EURISOL DS, in: Briefing Book for the Zeuthen Workshop, v.2 Book	M. Benedikt, M. Lindroos
Beam for European Neutrino Experiments (BENE), mid-term scientific report, CERN-2006-005	21 authors with I. Efthymiopoulos, R. Garoby, M. Lindroos and P. Sievers from CERN
A low energy accumulator ring, proceedings NUFACT06	A. Kaellberg, M. Lindroos, A. Simonson

4/ ACTIVITIES

The BENE network participated in the NUFACT06 workshop and school. The network also published an interim report.

CERN participates in the following work packages:

WP TARGET

MERIT (nTOF11) as a proof-of-principle target test for a multi-MW proton beam is carried out by the USA - Neutrino Factory and Muon Collider Collaboration. CERN collaborates for hosting this experiment, which will run in 2007. Contributions concern mainly the installation of power (5MW) and cryogenics, logistics and safety (people involved: I.Efthymiopoulos, A.Fabich, J.Letry). Beyond being a contact link to the externally located community, physicists are providing expertise on the layout of the mercury jet target and loop, and study the particle production of the liquid target concept.

WP NOVELL NEUTRINO BEAMS

The beta-beam part of the work package is the information backbone of the beta-beam design study within the EURISOL DS and serves as forum for neutrino physicists to meet the machine physicists working within the DS. Note that there is no neutrino physics work package within the design study and that the BENE meetings are the only forum for these two communities to meet.

5/ ACHIEVEMENTS

All deliverables have been achieved as planned (see the Table below). The main achievement in 2006 was the publication of the interim report for the BENE network.

List of deliverables achieved in 2005 with CERN participation.

Deliverable/ Milestone	Deliverable/Milestone Name	Work-package	Planned (in months)	Achieved (in months)
D	NuFact06 International Workshop Proceedings	All	20	20
M	BENE Meetings	All		16, 19
D	Interim Report (IR)	All	24	25

1.3 HHH Network Activities

1/ INTRODUCTION

In 2006, the activity of the HHH network was essentially focused on the FAIR project at GSI and the upgrade of the LHC accelerator complex at CERN.

The HHH activities are split in 3 work packages (WP):

- WP1: Advancements in Accelerator Magnet Technologies (AMT)
- WP2: Novel Methods for Accelerator Beam Instrumentation (ABI)
- WP3: Accelerator Physics and Synchrotron Design (APD)

Two specific HHH working groups created in 2005 continued to be active in 2006. The first, addressing issues such as accelerator physics and machine-detector interface aspects related to the upgrade of the LHC Interaction Regions, was strengthened and involved representatives of all the LHC detectors. The second investigating an appropriate R&D programme for pulsed superconducting magnets in view of the upgrade of the LHC injector complex and of FAIR at GSI was slowed down due to the longer time-scale of the involved programmes.

A networking support to crystal channeling and collimation started at the end of 2005 and continued all along 2006, providing a forum of discussion to which many associated institutes in Russia and US, such as IHEP, PNPI, JINR and FNAL, could contribute.

During 2006, CERN was participating in a number of HHH related meetings, the most important ones being:

- CC06, the HHH-APD mini-workshop, in which tests on crystal collimation were discussed and a final proposal of experimental tests suggested in the north-area of the CERN-SPS,
- A workshop in GSI dealing with collective phenomena in circular hadron accelerators,
- WAMDO, the HHH-AMT workshop in which design and optimization of superconducting magnet of next generation were discussed,
- HB2006, workshop in KEK in which code benchmarking, collective effects, machine protection and electron cloud for high brightness hadron beams were discussed,
- LUMI06, the HHH-APD workshop examining the roadmap for the upgrade of the LHC and GSI accelerators.

2/ MEETINGS

09-13 January 2006 (APD): T. Demma from Sannio University (Italy) visited CERN in the frame of the HHH collaboration on novel approaches to modeling the electron cloud build up in the LHC and its upgrade.

01 February 2006 (AMT): A special AT/MAS Magnet Seminar was organized at CERN. The talk “Test Results on the Model Nb₃Sn Dipole TAMU2” was presented by P. McIntyre to an audience of about 30 experts.

07-10 March 2006 (APD): The [International Workshop on Recent Progress on Induction Acceleration RPIA2006](#) KEK, Tsukuba, was attended by 45 world experts, including 2 members of CERN. Discussions focused on LHC upgrade, pulsed beam-beam compensators for LHC, and stronger kickers for upgraded injectors. CERN contributions:

- Possible Uses of Rapid Switching Devices and Induction RF for an LHC Upgrade, F. Zimmermann,
- Simulation of LHC Long-Range Beam-Beam Compensation with DC and Pulsed Wires, U.Dorda and F. Zimmermann
- Assessment of the Wire Lens at LHC from the current Pulse Power Technology Point of View, Summary of Working Group G3, co-organized by F. Zimmermann

09-10 March 2006 (APD): [CARE-HHH-APD mini-Workshop on Crystal Channeling](#), CERN. Discussion on beam experiments, crystal production, and research programm. About 20 participants. CERN contributions:

- Plans for crystal collimation, W. Scandale,
- SPS H8 beam facility for crystal validation, L. Gatignon,
- Beam characteristics in H8, I. Eftthymiopoulos

23 March 2006 (AMT/APD): A special AT/MAS Magnet Seminar was organized at CERN. The talk about "Studies of Low Crossing Angle Bumps for the LHC Luminosity Upgrade" was presented by G. Sterbini to an audience of about 20 experts.

30-31 March 2006 (APD): [CARE-HHH-APD CERN-GSI bi-lateral working meeting on Collective Effects–Coordination of Theory and Experiments](#), GSI, Darmstadt, Germany. Five participants from CERN attended. CERN contributions:

- [Overview of Electron-Cloud Effects in the LHC and Present Understanding \(Addendum\)](#) F. Zimmermann
- [Beam Loss and Beam Degradation in the PS & SPS](#) E. Metral
- [Bunch Shortening, Working Point and Chromaticity Issues in the SPS](#) G. Arduini
- [Studies of the LHC beam loss in the SPS](#) E. Shaposhnikova
- [Bunch Shortening at SPS](#) G. Rumolo
- [Effect of Space Charge on Landau Damping](#) E. Metral
- [Loss of Landau Damping in the SPS](#) E. Shaposhnikova
- Future Experiments at CERN G. Arduini
- [Resistive-Wall Impedance from Exact Field Matching](#) E. Metral
- [Resistive-Wall Impedance and Induced Tune Shifts](#) F. Zimmermann
- [Kicker Impedance Bench Measurements](#) E. Metral
- [TMC Instability Simulations and Benchmarking](#) G. Rumolo

03-06 April 2006 (AMD): [CARE-HHH-AMT Workshop on Accelerator Magnet Design and Optimization \(WAMDO\)](#), CERN. CERN contributions:

- Beam optics and layout for the luminosity upgrade by F. Ruggiero, R. Ostojic, D. Denegri, J.P. Koutchouk.
- High field superconductors by L. Oberli, A. Ballarino.
- Design tools, potential and limitations by S. Russenschock, A. Ferrari.
- Magnet design by E. Todesco, P. Fessia
- Main issue design of cycled (Hs range) magnets by A. Vervweij, G. Kirby
- New concepts and perspectives by G. de Rijk

11 April 2006 (coordination): CARE Joint Steering Committee and Dissemination Board Meeting, LPNHE, Paris; 10 participants from CERN. CERN-HHH contribution:

- HHH Status Report, W. Scandale

26-28 April 2006 (coordination): [US-LARP Collaboration Meeting](#), LBNL, USA. CERN contribution:

- Recent Evolution at CERN, H. Schmickler

10 May 2006 (dissemination): At the 55th meeting of the LHC Technical Committee (LTC), W. Scandale presented options for the LHC IR upgrade.

29 May - 2 June 2006 (dissemination): [Advanced ICFA Workshop on High Brightness Hadron Beams \(HB2006\)](#), KEK, Tsukuba. Discussions on high brightness hadron beams, code benchmarking, collective effects, machine protection, and electron cloud. CERN-HHH contributions:

- LHC Upgrade Options and CARE-HHH Activities, F. Zimmermann
- Electron-Cloud Benchmarking & CARE-HHH Codes, F. Zimmermann

9 June 2006 (dissemination): J.-P. Koutchouk discussed the "Low Crossing Angle Scheme for the LHC Luminosity Upgrade" at the 1st LHC Upgrade Machine Experiment Interface Meeting.

21 June 2006 (APD): At the 58th meeting of the LHC Technical Committee (LTC), W. Scandale presented a proposal for crystal collimation experiments for the SPS.

26-30 June 2006 (dissemination): Contribution of 14 talks and papers to EPAC'06, Edinburgh, including an invited overview presentation by W. Scandale on "LHC Luminosity and Energy Upgrades".

03-07 July 2006 (dissemination): At the [International Conference on Charged and Neutral Particles Channeling Phenomena "Channeling 2006"](#), W. Scandale reviewed prospects of channelling for hadron-beam collimation.

27 July 2006 (APD): In the frame of a CERN AB Seminar, E. Benedetto explained the emittance growth induced by the electron cloud in CERN proton rings to about 50 specialists.

27 July 2006 (APD): A small working group on crab cavities for the LHC upgrade was launched and met for the first time. It comprises some 6 members, from HHH and US-LARP. Further meetings followed on 11 August, 19 September, and 12 October.

1 September 2006 (dissemination): W. Scandale presented an "Overview of LHC Upgrade Scenarios" and G. Sterbini "Parameters for an Early Beam Separation Scheme" at the 2nd LHC Upgrade Machine Experiment Interface Meeting.

27 September 2006 (dissemination): F. Zimmermann gave a seminar on "R&D for Future Accelerators" at the University of Pisa.

1 October 2006 (dissemination): F. Zimmermann presented the "Machine Plans for the LHC Upgrade" at the ATLAS Upgrade Workshop.

6 October 2006 (dissemination): W. Scandale and F. Zimmermann reviewed the extent of the "luminous region, collisions with displaced beams, and the feasibility of 50 ns bunch spacing," while J.-P. Koutchouk investigated the "parameter space for the luminosity upgrade" at the 3rd LHC Upgrade Machine Experiment Interface Meeting.

11-12 October 2006 (AMT): [CARE-HHH-AMT: LER - Workshop on the Low Energy Ring study](#), CERN, Geneva. CERN contributions: attendance to the workshop of about 30 CERN staff contributing to the general discussion with 5 of them acting as 'advocate of devil' for technically difficult items.

16-20 October 2006 (APD): [CARE-HHH-APD Workshop Towards a Roadmap for the Upgrade of the LHC and GSI Accelerator Complex \(LHC-LUMI-06\)](#), [IFIC](#), Valencia, Spain.

CERN contributions:

- IR upgrade, by W. Scandale, P. Grafstrom, O. Bruning, R. de Maria, J.P. Koutchouk, G. Sterbini, E. Laface, P. Limon, E. Todesco, U. Dorda, R. Tomas, J. Tuckmantel,
- IR ranking, by W. Scandale, F. Zimmermann
- Injector upgrade, by W. Scandale, F. Zimmermann, G. Arduini, R. Schmidt, R. Assmann, E. Shapshnikova, W. Hofle, S. Hancock, M. Benedikt, G. Rumolo, R. Garoby, B. Goddard
- Summary of injector upgrade discussion, by W. Scandale, F. Zimmermann

30 November – 1 December 2006 (ABI): 4th CARE-HHH-ABI workshop on *Simulation of BPM Front-End Electronics and Special Mechanical Designs*, Lüneburg, Germany. Topics are BPM technology and modern design tools.

3/ PUBLICATIONS

List of reports with CERN authors in CARE-HHH

CARE document type and number	Title	CERN Authors	Date
CARE Report			
Report-06-008-HHH	Annual Report 2005 of the HHCcollaboration	Editors F. Ruggiero, W. Scandale	Jan 06
Report-06-028-HHH	CARE-HHH Network: Second Quarterly Report 2006	F. Ruggiero, W. Scandale, F. Zimmermann	Aug 06
CARE Conference			
Conf-06-010-HHH	Non-linear Collimation in Linear and Circular Colliders	J. Resta-López F. Zimmermann	June 06
Conf-06-014-HHH	Proceedings of the LHC-LUMI-05 Workshop	Ed. F. Ruggiero, W. Scandale, F. Zimmermann	July 06
Conf-06-020-HHH	LHC Upgrade Options and CARE-HHH Activities	F. Zimmermann	June 06
Conf-06-021-HHH	Electron-Cloud Benchmarking and CARE-HHH Codes	F. Zimmermann	June 06
Conf-06-022-HHH	LHC Luminosity and Energy Upgrades	W. Scandale	June 06
Conf-06-023-HHH	Accelerator Physics Code Web Repository	F. Zimmermann et al	June 06
Conf-06-024-HHH	Possible Uses of Rapid Switching Devices and Induction RF for an LHC Upgrade	F. Zimmermann	March 06
Conf-06-025-HHH	Assessment of the Wire Lens at LHC from the current Pulse Power Technology Point of View	F. Zimmermann, U. Dorda	March 06
Conf-06-026-HHH	Simulation of LHC Long-Range Beam-Beam Compensation with DC and Pulsed Wires	U. Dorda, F. Zimmermann	March 06

Conf-06-027-HHH	Simulation Study on the Energy Dependence of the TMCI Threshold in the CERN-SPS	G. Rumolo, E. Métral, E.N. Shaposhnikova	June 06
Conf-06-028-HHH	Benchmarking Electron Cloud Data with Computer Simulation Codes	G. Rumolo	June 06
Conf-06-029-HHH	Maps for Electron Clouds: Application to LHC	F. Ruggiero, G. Rumolo, F. Zimmermann	June 06
Conf-06-030-HHH	Observation of the Long-range Beam-beam Effect in RHIC and Plans for Compensation	U. Dorda, J.-P. Koutchouk, F. Zimmermann	June 06
Conf-06-031-HHH	Resonance Trapping, Halo Formation and Incoherent Emittance Growth due to Electron Cloud	E. Benedetto, G. Rumolo, F. Zimmermann	June 06
Conf-06-032-HHH	An Alternative Nonlinear Collimation System for the LHC	J. Resta Lopez et al	June 06
Conf-06-033-HHH	An Early Beam Separation Scheme for the LHC	J.-P. Koutchouk, G. Sterbini	June 06
Conf-06-034-HHH	Investigations of the Parameter Space for the LHC Luminosity Upgrade	J.-P. Koutchouk	June 06
Conf-06-035-HHH	Interaction Region with Slim Quadrupoles	E. Laface, R. Ostojic, W. Scandale, D. Tommasini, C. Santoni	June 06
Conf-06-036-HHH	Proceedings of the AMT ECOMAG Workshop	L. Bottura et al.	June 06
Conf-06-045-HHH	LHC IR Upgrade: A Dipole First Option with Local Chromaticity Correction	R. de Maria, O.S. Brüning	June 06
Conf-06-046-HHH	A Low Gradient Triplet Quadrupole Layout Compatible with NbTi Magnet Technology & $\beta^* = 0.25\text{m}$	R. de Maria, O.S. Brüning,	June 06
Conf-06-049-HHH	Proceedings of the AMT WAMDO Workshop	T. Taylor et al.	Nov 06
CARE Note			
Note-2006-013-HHH	Main Outlines of the Workshop on Beam Generated Heat Deposition and Quench Levels for LHC Magnets	R. Assmann et al.	Sept 06
Note-2006-014-HHH	Use of HERA Magnets for the SPS+SLHC Transfer Lines Possible Upgrade of the LHC Injection Lines to 900 GeV using HERA Dipoles	K.-H. Mess, D. Smekens	Sept 06
Note-2006-018-HHH	Database Design for SC Magnets	E. Laface, T.-J. Cho	Nov 06

4/ ACTIVITIES

Deliverables: The web based database for SC Cables and Magnets is well advanced in the frame of WP1 (AMT). Benchmarking parameters, examples and overview tables were added to the accelerator physics code repository of WP3 (APD). Work on a structured list of intensity limitations has begun in WP3. (APD)

Events: A total of 4 workshops were organized, two in the frame of WP1 (AMT), and two in the frame of WP3 (APD). The participation was large. It included not only representatives from several European HHH partner laboratories, but also from Japan, and in particular a strong presence from the US-LARP. In addition, a CARE-HHH bilateral GSI-CERN meeting was organized in the frame of WP3 (APD). The WP2 (ABI) workshop is planned at the end of November.

Dissemination and outreach: The effort for dissemination of information was further intensified. Numerous invited talks were delivered, mostly by the HHH coordinators, which illustrated the HHH activity for various CERN committees, to the LHC experiments, at universities, and at workshops organized by other institutions. Seventeen new publications were issued, most of which are already stored in the CARE database. The HHH web site was continually updated.

Exchanges and educational aspects: One US accelerator specialist was hosted by CERN with the support of HHH in the frame of WP1 (AMT). Two junior scientists active in HHH issues were hosted and supported, one by CERN in the frame of WP1 (AMT), the other by the University of Sannio, Benevento, Italy, in the frame of WP3 (APD). Two summer students, one master degree student, and

five doctoral students were active at CERN on issues related to WP1 and 3 (AMT and APD), namely IR upgrade and web databases. The first US-LARP Toohig fellow was also hosted at CERN for a period of six months.

Spin-off from HHH-ABI workshops: In the frame of WP2 (ABI), the CERN –DESY collaboration was strengthened: M. Werner of DESY visited CERN for an expert audit of the LHC machine protection system; the FCMC (Fast Magnet Current Monitor) developed at DESY has become an integral part of the LHC machine protection system, and more than 20 units will be produced in order to monitor the stability of the supply current of key warm magnets in the LHC; the LHC BLM system is under test in HERA with remote control from CERN; quench levels at HERA were newly calculated and associated analyses of beam induced quenches at HERA were presented at HB2006. Triggered by the 3rd WP2 (ABI) workshop (addressing GAN, MVL, VII, diagnostics work packages), a first experiment to test remote communication between office or home and a team in the tunnel was successfully performed at DESY. WP2 spin-off in the US included the LHC @ FNAL control room project, and the new initiative "LAFS" (LHC application Fermilab software), which is developing essential add-one to the LHC control system, e.g., RBAC = Role Based access.

5/ ACHIEVEMENTS

The following table gives the status with respect to the interim reports and deliverables to be done in 2005 according to the project breakdown in Mile-Stones (MS) and Intermediate Deliverables (ID).

WB	Title	Due date	Status	Revised date
General	MS: annual HHH meeting	T4-2006	0 %	T4-2006
	ID: Annual Report 2006	T4-2006	70%	T4-2006
WP1-AMT	ID: Proceedings of AMT mini-workshop on Beam Generated Heat and Magnet Quench Level	T1-2006	100 %	T3-2006
	MS: specific meeting on s.c. database	T2-2005	100 %	T1-2006
	ID: first report on web based s.c. database	T2-2005	100 %	T4-2006
	MS: AMT workshop on Accelerator Magnet Design and Optimization (WAMDO)	T2-2006	100%	T2-2006
	ID: Proceedings of AMT WAMDO workshop	T3-2006	98%	T4-2006
	MS: AMT workshop on Coil Manufacturing Optimization	T1-2006	0%	T4-2007
	ID: Proceedings of the AMT workshop ECOMAG-05	T1-2006	100%	T4-2006
	MS: preliminary report on scaling law for magnets and cryogenic cost for AMT5	T2-2006	0%	T2-2007
	MS: Possible AMT Workshop on HF and LF Magnets	T3-2006	50%	T3-2007
	Preliminary Report on scaling law for magnet and cryogenic cost	T2-2006	0%	T1-2008
WP2-ABI	ID: proceedings of the third ABI workshop	T1-2006	100 %	T1-2006
WP3-APD	MS: 2nd APD mini-workshop on Crystal Collimation	T1-2006	100%	T4-2005
	ID: Proceedings of the 2nd APD topical workshop (LUMI-05)	T4-2005	100%	T3-2006
	MS: Creation of a web reference for alternative IR and synchrotron optics	T2-2006	50 %	T4-2007
	ID: First structured list of intensity limits for booster synchrotrons and LHC	T3-2006	20 %	T2-2008
	MS: 3rd APD topical workshop on Fast Synchrotrons and IR design	T3-2006	100%	T4-2006
	ID: Proceedings of the 3rd APD topical workshop	T4-2006	0%	T1-2007

The workshop on Coil Manufacturing Optimization was postponed to September 2007 for better organization and preparation. The schedule for the derivation of scaling laws for magnet and cryogenic cost has been extended, due to lack of resources. The development of the database for s.c. magnets and cables, which was slow in previous years, has made good progress in 2006. This task is almost 50% completed. The APD web reference for synchrotron optics and the structured list of intensity limitations for the booster synchrotrons have both been slower than expected. The delay was primarily caused by the reorganization of the injector upgrade studies inside CERN, and by inconsistent internal schedules and priorities.

1.4 CARE PHIN Joint Research Activities

1/ INTRODUCTION

During 2006, CERN was participating in

- Design of the RF Gun (responsibility of LAL-Orsay).
- Design of the Laser (responsibility of CCLRC-RAL) and purchasing of components of the laser (shared responsibility between CERN and CCLRC-RAL).
- Refurbishing of the CERN photocathode lab and upgrade of diagnostics for the monitoring of the deposition of photo-emissive films.
- CARE Steering Committee activities (R. Losito, deputy coordinator of PHIN).

2/ MEETINGS

CERN – CCLRC/RAL

Several videoconferences and visits were organized to followup the design and procurement of the laser system and of the different components. Visits (one or two weeks) of a CERN technical engineer were arranged in order to gain experience with the laser system.

- 13-17 March 2006 :** One week visit of N. Champault to RAL to participate in setting up of the first amplifier.
- 12-16 June 2006 :** One week visit of N. Champault to RAL to participate in setting up the second amplifier.
- 23 June 2006 :** Special CLIC meeting devoted to the photo-injector. Visit of G. Hirst and G.Kurdi to CERN.
- 3-14 July 2006 :** One week visit of N. Champault to RAL to participate in setting up the second amplifier and measurements on frequency multiplication.
- 10 November 2006:** A videoconference was organized to follow-up the design and procurement of the laser and of the different components (R. Losito, V. Fedosseev, E. Chevally, N. Champault, L. Rinolfi)

CERN – LAL

Several videoconferences were organized to followup the design and procurement of the RF Gun and of the different components.

- 10 January 2006 :** project status review at LAL (CERN: R. Losito)
- 14 February 2006 :** Technical meeting about brazing of the RF-Gun (CERN: S. Mathot).
- 14 February 2006 :** Videoconference about the project status (CERN: R. Losito, H. Braun, G. Geschonke)
- 23 February 2006 :** Technical meeting at LAL about integration of the Gun in CTF3 (CERN: E. Chevally)
- 15 May 2006 :** Technical meeting about low level measurements on the RF Gun cold model (CERN: R. Losito).
- 13 Septembre 2006 :** Technical meeting about project status and preparation fro transport to CERN of the RF Gun (CERN: E. Chevally).

3/ PUBLICATIONS

The PHIN-Documents are kept in:

<http://www.infn.it/phin/docs.html>

Cern contribution for 2006 is:

CARE-Conf-06-019-PHIN : R. Losito et al., “The PHIN photo-injector for the CTF3 drive beam”, EPAC '06, Edinburgh.

Dissemination Talks:

R. Losito “The PHIN photo-injector for CTF3”, CLIC Meeting, CERN, 23/06/2006

R. Losito “Cs₂Te Photo-cathodes for CTF3 Photo-injectors”, Workshop on High QE Photo-cathodes for RF Guns, INFN-LASA, 4/10/2006

L. Rinolfi “Status report for CTF3 photo-injector for the JRA2 “PHIN””. CARE Annual meeting, INFN-LNF, 15/11/2006.

4/ ACTIVITIES

WP2: Photo-cathodes

In the first part of 2006 we started the commissioning of the photocathode lab. Few more leaks obliged us to re-work some UHV components. A few diagnostic components (i.e. a wall current monitor) and some control software will be added in 2007.

The DC Gun, used to pre-qualify the photocathode performance was baked out until a pressure close to 10^{-10} mbar was reached. Following this operation, it was possible to condition the Gun up to its nominal field of 10 MV/m with a copper photocathode (without any photo-emissive coating). This process was repeated with a photocathode with a bulk quartz substrate to prove that no problems arise with such material, in view of the possible use of Secondary Emission Yield photo-cathodes. Fig. 1 shows the profile of vacuum level during conditioning.

With the deposition chamber fully refurbished, an intense campaign of calibration of all the diagnostic equipment has started. A calibrated diagnostic will allow to control several parameters of the deposition process and ensure a good reproducibility of the Quantum Efficiency of the photo-cathodes in Cs₂Te. The most significant technique in our installation is to read the thickness directly on two independent quartz microbalances positioned in the vicinity of the photocathode during deposition. A 3D study has been carried out to determine convenient mechanical masks to install during the deposition process to protect the Te balance from Cs and vice versa. The masks have been simulated with CATIA and then manufactured, and according to our first measurements the rejection of the unwanted species is now better than a factor 150. The masks are shown in fig. 1.

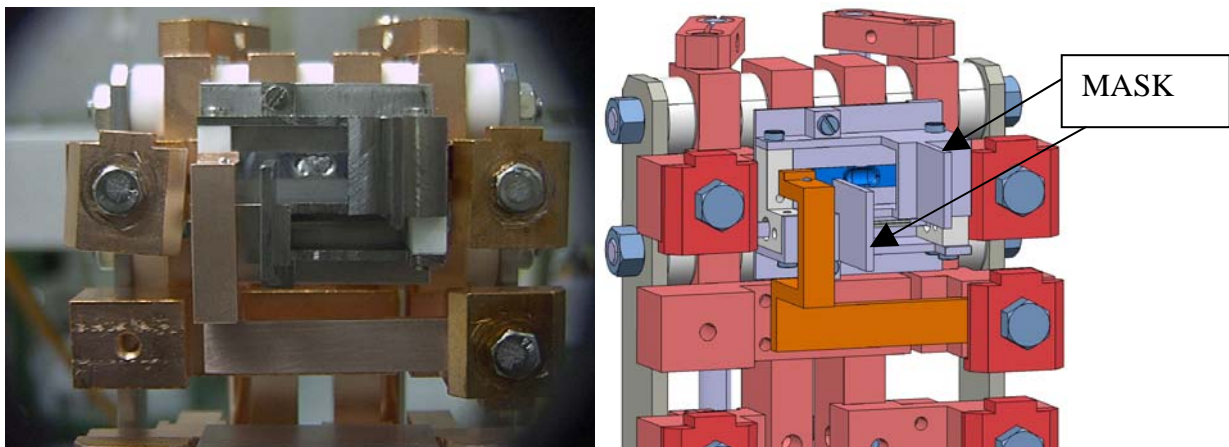

Fig. 1: A picture and the 3D drawing of the deposition ovens and the masks to protect the microbalances.

After verification of the independence of the measurements from the unwanted element, the calibration of the microbalances has started. Several photo-cathodes were deposited with only one element, then the thickness of the thin film measured with different techniques:

- special photo-cathodes made of quartz have been deposited to measure the optical transmission of the sample. Though this measurement does not give an absolute measurement of the thickness of the film, it allowed to optimize the shape of the mask to maximize the quantity of elements arriving to the photocathode.
- Measurement of absolute thickness using a precision roughness-meter. A new optical roughness-meter has been installed in the CERN metrology department. The theoretical measurement accuracy is 0.1 nm. Some test measurements have already been performed, but several tricks need to be implemented to get a meaningful measurement with the desired accuracy. For this reason it has been decided to purchase a mechanical stylus surface profiler dedicated to our activity. The accuracy is also of 0.1 nm.

The integration of the RF Gun into the layout chosen for the off-line test has been fixed and drawn in 3D to check for interferences (see fig. 2). Several criticalities among the different parts of the photo-injector and measurement line have been solved thanks to detailed modeling.

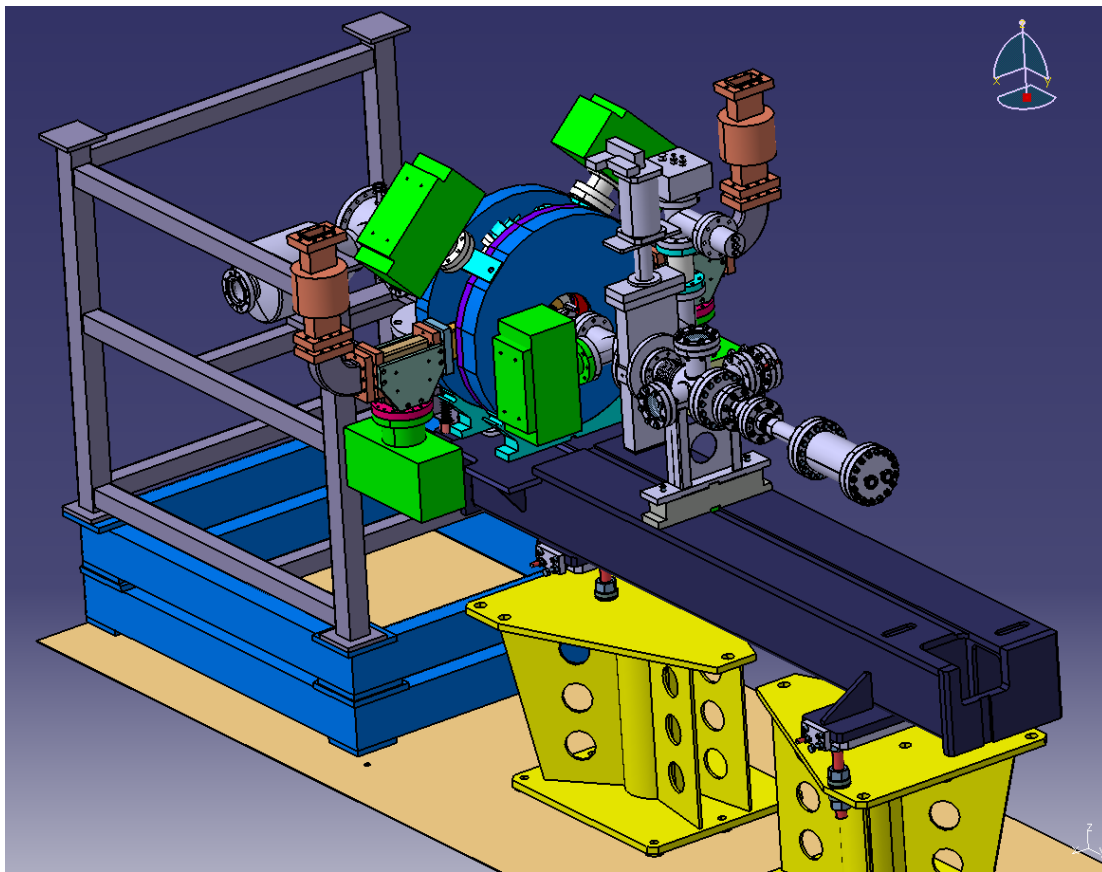

Fig. 2: Integration layout of the photo-injector.

WP 3: Laser.

CERN participated actively to the design and procurement of all the components for the laser for CTF3, as well as to the assembly and commissioning of the laser at RAL. It has to be underlined that RAL did not complete the demonstration of laser performances and commissioning with the pretext that European funds did not cover the manpower for the extended period due to delays in the scientific work, (nearly 9 months with respect the planned duration). CERN and RAL agreed to ship all the laser components to CERN, and an associate from Hungary previously working at RAL on this project, G. Kurdi, has been hired at CERN for 3 months to pass on the know-how and the information about the

work already performed at RAL. The work at CERN started in September, the oscillator, the preamplifier and the first amplifier have already been commissioned.

WP 4: RF Gun.

CERN has followed closely the manufacturing of the RF Gun for CTF3 through regular meetings and videoconferences, however the RF Gun planning is slipping without any evident reaction from LAL's management. There have been long delays (more than one year now) in the manufacture of copper parts of the RF Gun. Also, the cold model built to confirm the simulations showed huge discrepancies between measurements and simulations, that obliged LAL to modify the design. The differences have now been understood thanks to the work of a CERN technical student, who showed that the final technical drawings did not correspond to the simulated geometry. LAL committed to send parts of the Gun to CERN for brazing by the end of September, but the planning has not been respected.

These delays put the whole project in jeopardy, since the installation of the RF Gun in the CTF2 has to be finished before the start-up of CTF3 in 2007. Failing this date would mean shifting the whole schedule to the next shutdown (2007/2008). Since the RF Gun has to undergo brazing and installation of special bake-out jackets at CERN, and both services are overbooked till the start-up of the LHC and beyond, it is unrealistic today to believe that the photo-injector can be tested in 2007.

However the possibility of modifying the CTF3 schedule in 2007 to allow the installation of the gun in CTF2 will be studied once the real schedule of the RF gun will be known.

5/ ACHIEVEMENTS

Laser components have been delivered from RAL on August 28. The assembly and commissioning of laser components has started.

Several inconsistencies in the calibration of the thickness measurements in our photocathode laboratory have been clarified and the deposition of Cs₂Te films will start now with the aim of stabilising the stoichiometric ratio during deposition and across different photocathodes.

Concerning the RF Gun, the situation is now critical, and it is unrealistic to expect delivery of the RF Gun in time for installation before the start-up of CTF3 in 2007. Alternative solutions are under discussions with the CTF3 management.

1.5 CARE HIPPI Joint Research Activities

1/ INTRODUCTION

During 2006, CERN was participating in

- Management of the Activity (WP1).
- Development of Normal-Conducting linac design, prototype construction and testing (WP2).
- Construction of beam chopping line components and chopping line analysis (WP4).
- Beam dynamics and diagnostics for high intensity linacs (WP5).

2/ MEETINGS

Work Package Meetings:

a. WP2 (Normal Conducting RF) Meeting (LPSC, Grenoble, May 18-19, 2006)

At the meeting the DTL (Drift Tube Linac) design for Linac4 (CERN, with contributions from LPSC and CEA) and the mechanical design of the DTL realised by VNIIEF Sarov (ISTC Collaboration) were presented. Other contributions concerned the measurement results on the CERN CCDTL (Cell Coupled DTL) prototype and the calculations of stability for long Side Coupled Linac (SCL) chains, realised at CERN, LPSC and INFN-Neaples. Further presentations concerned the progress of the CH (Chopping) structure design for FAIR and of the RAL chopping line design.

b. WP4 (Chopping) Meeting (CERN, May 4-5, 2006)

Twelve people from CERN participated in this 2-day workshop. The highlights of the discussions were the calculations and measurements of the field coverage factor of the chopper as well as the status of the key components and the possibility to test the chopper elsewhere than CERN. The impact of measuring the chopper on a 3 MeV beam line in Saclay was evaluated, this solution was eventually adopted.

c. WP5 (Beam Dynamics) Meeting (FZJ, Jülich, April 27-28, 2006)

The meeting of WP5 was organised jointly with WP3 (Superconducting structures) and was particularly devoted to the discussion of optimised linac designs for the energy range 90-200 MeV, based on spoke and elliptical superconducting cavities. Other presentations concerned the latest results of the benchmarking for beam dynamics codes with measurements done at the GSI UNILAC.

ISTC Collaboration Meetings

These meetings are intended to coordinate the construction in Russia of the three prototype structures for Linac4 funded by ISTC. These structures are not part of HIPPI (different funding) but their specifications result from the HIPPI work and their status and performance are analysed in HIPPI.

- **March 27-30**, BINP Novossibirsk (RU): status of CCDTL prototype, preparation of SCL model.
- **April 5-7**, CERN: DTL mechanical design.

HIPPI Annual Meeting (FZJ, Jülich, September 27-29, 2006)

The complete activity of HIPPI was reviewed (37 participants from 15 laboratories – 6 from CERN -, with 28 presentations during 2.5 days). The slides of all presentations and the list of participants are available on the meeting web site (<http://www.fz-juelich.de/ikp/hippi/autumn2006/>). This year the meeting included general presentations on the status of the projects supported by HIPPI and on general topics at the boundary between Work Packages, as well as the usual presentations focused on the progress inside Work Packages. CERN contributed 6 technical presentations and 3 general presentations (adding up to 32% of all presentations) plus the organizational and introductory talks. All three members of the External Scientific Advisory Committee (ESAC) were present (Y. Yamazaki from JPARC, A. Pisent from INFN and J. Stovall from LANL-SNS) and expressed their appreciation for the quality and amount of work. The final ESAC report will be prepared in time for the CARE Meeting.

3/ PUBLICATIONS

The list of HIPPI Documents and Notes is available on the HIPPI web site:

http://mgt-hippi.web.cern.ch/mgt-hippi/publications/HIPPI_PAPERS.htm

List of reports with CERN authors in HIPPI/CARE

CARE/HIPPI notes	Title	Authors and Labs
Note-2006-004-HIPPI	The beam absorbers of the 3 MeV H-Test Facility at CERN	L.Bruno, A.M.Lombardi, M.Magistris, M.Silari, CERN.
Note-2006-009-HIPPI	Superconducting Spoke Linac Design as an Alternative Option for the CERN Linac4 High Energy Part	E. Sargsyan, A.M. Lombardi, CERN.
Note-2006-011-HIPPI	Linac Code Benchmarking in Preparation of the UNILAC experiment	A. Franchi, W. Bayer, G. Franchetti, L. Groening, I. Hofmann, A. Orzhekhovskaya, S. Yaramyshev, X. Yin GSI, Germany; A. Sauer, R. Tiede, C. Clemente IAP, Frankfurt am M., Germany; R. Duperrier, D. Uriot CEA, Saclay, France; G. Bellodi, F. Gerigk, A.M. Lombardi, T. Muetze CERN.
Note-2006-012-HIPPI	Field Stabilisation with Post Couplers for DTL tank1 of Linac4	N. Alharbi, F. Gerigk, M. Vretenar, CERN.
Note-2006-017-HIPPI	The CERN SPL Chopper Structure: A Status Report	T. Kroyer, F. Caspers, E. Mahner, CERN
CARE CONFERENCE	Title	Authors and Labs
Conf-06-007-HIPPI	Error study of LINAC 4	E. Froidefond, M. Baylac, JM de Conto (LPSC-Grenoble, France) E.Z. Sargsyan (CERN)
Conf-06-005-HIPPI	A Fast Beam Chopper for the RAL Front-End Test Stand	M A Clarke-Gayther (CCRLC), G Bellodi, F. Gerigk (CERN)
Conf-06-018-HIPPI.	Linac4, A New Injector for the CERN PS Booster	R. Garoby, G. Bellodi, F. Gerigk, K. Hanke, A.M. Lombardi, M. Pasini, C.Rossi, E.Z. Sargsyan, M. Vretenar,CERN.
Conf-06-038-HIPPI	Measurement Strategy for the CERN Linac4 Chopper-Line	JB. Lallement, A. M. Lombardi, E. Z. Sargsyan, M. Hori, K. Hanke, CERN.
Conf-06-039-HIPPI	End-To-End Beam Dynamics for CERN Linac4	A.M.Lombardi, E.Z. Sargsyan, S. Lanzone, J-B Lallement, G. Bellodi, CERN, M. Baylac, LPSC Grenoble, R. Duperrier, D. Uriot CEA, Saclay
Conf-06-044-HIPPI	Design And Development of RF Structures for Linac4	M. Vretenar, N. Alharbi, F. Gerigk, M. Pasini, R. Wegner, CERN
HIPPI documents	Title	Authors and Labs
HIPPI Document-06-0001	Comparison of PathManager and TraceWin codes for beam dynamics.	J.B. Lallement,CERN

4/ ACTIVITIES

For WP1 (Management and communication), CERN is providing the activity coordinator (M.Vretenar) and its deputy (A.Lombardi). The Coordinators have prepared 2 Quarterly Reports and are preparing the Annual Report, have discussed and updated the planning, are keeping the database of HIPPI Publications, have prepared the HIPPI Annual Meeting at FZJ Jülich and lead the discussions with the External Scientific Advisory Committee.

In WP2 (Normal Conducting Structures), CERN participates to the DTL design activity, to CCDTL design and prototyping and to the SCL design and modelling. All these structures are used for Linac4. In general terms, 2006 was devoted to the detailed development or improvement of mechanical solutions for DTL and CCDTL, and to the preparation of models for the SCL.

For the DTL, the main outcome was the presentation by the VNIIEF Sarov team at CERN in March 2006 of the proposed mechanical layout of the DTL prototype for Linac4. This layout has been extensively analysed and discussed at CERN during and after the meeting, and inside HIPPI during the HIPPI meetings, with the HIPPI contributors and with the External Advisory Committee. Some design corrections were asked in March and are now integrated into the design. However, doubts remain on some technical choices that have still to be validated (laser welding of drift tubes and mechanical fixation of drift tubes), on the lack of a general strategy for assembly and alignment and on the fact that the prototype will not be equipped with the complete set of copper drift tubes and therefore cannot be tested at high power. These worries together with the announced 5-month delay in the construction of the prototype have forced the CERN team to start at the end of the year developing a simplified DTL design, which could be used as a backup solution in case of problems with the Sarov design. As for the DTL power coupler developed and built by CEA and LPSC, it is being machined and will be delivered on schedule.

For the CCDTL, the high power RF tests of the prototype built at CERN started only in September 2006. Additional delay was caused by repairing a number of vacuum leaks due to substandard work at the CERN workshop and to lack of control on outsourced components, with everything made more difficult by the lack of resources in the AT-VAC group. However, the results of the power tests are very encouraging; the gradient and duty cycle required for Linac4 were achieved after a very short and uneventful conditioning. Unfortunately, operation at the higher SPL duty cycle was not possible because of one more machining problem discovered in one of the drift tubes, which will force to a difficult repair to be done in the first months of 2007. The CCDTL prototype built in Russia (VNIITF Snezhinsk and BINP Novossibirsk) has been delivered to Novossibirsk and inspected during a visit in March 2006, but its completion has been delayed until October because of the BINP workshops overload with the last components for LHC. The mechanical execution looks correct, but there are some questions on the quality of copper plating, which can be answered only by the first RF measurements foreseen by end 2006.

For the SCL, only theoretical studies (stability of long chains of coupled cells) were done in 2006, because of the delay at LPSC Grenoble in building the cold SCL model (due to problems with their workshop and to the lack a PhD student taking over this study). Eventually, the model should be finished before the end of 2006.

In WP4 (chopper), CERN is responsible for the construction of a fast-switching electrostatic deflector based on a meander line printed on an alumina substrate and adapted to the velocity of 0.08c (3MeV proton beam). The activity advanced steadily and low power measurements have started on the chopper plates. Measurement of the prototype with high power will be possible after the completion of all the vacuum tests which were the bottleneck for the chopper prototype testing.

The chopper structure is fully assembled since December 05. Because of the workload of the AT/VAC group, vacuum tests could start only in the second part of 2006 and are now just about completed. The results of the out-gassing test on the chopper deflecting structure were successful without in situ bake-out. In particular this test cleared any doubts related to vacuum outgassing pockets (the space between the ceramic plate and the alumina plate). The second vacuum test, related to the cooling needed to cope with electrical heating and beam losses has been performed in the fall 2006. It shows that the thermal resistance between the ceramic plate and the cooled ground plate is

below 1 °K/W in vacuum, which allows for 100 W of dissipated power on each of the chopper plates. This figure is in excess of what is foreseen in the most demanding scenario. Next year high power tests on the chopper will be performed.

Preliminary measurements on a prototype of the chopper amplifier ordered from FID Technology in Russia are very promising even if more work is needed to meet the full specifications of the chopper driver. The first of four modules should be available by the end 2006.

The dump is fully assembled and ready to be integrated in the beam line.

In WP5 (Beam Dynamics), CERN participated with the code PATH to the benchmarking of codes being done at GSI. The work on the codes for the 3 MeV test stand is well advanced. As for the beam shape and halo monitor, an improvement of the electron-beam transport has been implemented. This modification, which entails the addition of a pre-accelerating grid to the secondary electron transport system, has been validated by calculations and should improve the time resolution of the detector. Experimental tests with a laser beam should be done soon and shortly afterwards tests with beam will be performed at the tandem accelerator in Orsay.

5/ ACHIEVEMENTS

The 2006 planning had only one deliverable by CERN, the completion of the chopper prototype, due in August 2006. Thanks to last year's change of planning to cope with the overloaded CERN workshop, the chopper prototype could be finished on time. Electrical characterisation and low power tests have been completed and are successful. They are summarised in a CARE Note and AB/RF note. The other milestone foreseen for 2006, the code preparation of the 3MeV test stand has been achieved. A tool to compute the beam in the 3 MeV test stand, has been developed and benchmarked against other codes. The planned measurement could be simulated with high accuracy and the resolution of the diagnostics has been confirmed. Two milestones carried over from 2005 have been achieved in 2006: these are the CCDTL pre-prototype intermediate report and the chopper test intermediate report. Both those activities were delayed because of the overload of the CERN mechanical workshop.

List of deliverables achieved in 2006 with CERN participation.

Deliverable/ Milestone	Deliverable/Milestone Name	Work- package No	Planned	Achieved
M	CCDTL pre-prototype: intermediate report	2	June 2005	October2006
M	Chopper intermediate test report	4	March 2005	October 2006
D	Chopper prototype ready	4	August 2006	August2006
M	Code preparation f or 3 MeV test stand	5	June2006	June2006

1.6 CARE NED Joint Research Activities

1/ INTRODUCTION

In the frame of the NED Joint Research Activities, CERN is in charge of the conductor development to produce high performance Nb₃Sn wires and cables in collaboration with EU industry. The two firms SMI(NL) and Alstom-MSA(F) are working on the second step of the development plan, intended to qualify the final strand design. After having encountered serious difficulties in strand manufacturing during the first step of the development program, Alstom-MSA was successful to manufacture a sub-element suitable for NED applications. This sub-element design is being used for Step 2 keeping a very similar filament layout. SMI was successful to develop during Step 2 a strand comprising 288 Nb₃Sn filaments which achieved a critical current density of 2500 A/mm² at 12 T and 4.2 K.

2/ MEETINGS

Follow-up meetings of the conductor development:

- 10-11 January 2006: meeting with Alstom-MSA at CERN, T. Boutboul, D. Leroy, L. Oberli
- 14 March 2006: meeting with SMI at CERN, T. Boutboul, D. Leroy, L. Oberli
- 10-11 April 2006: visit of T. Boutboul, D. Leroy, L. Oberli to Alstom-MSA
- 28 June 2006: visit of T. Boutboul, L. Oberli to Alstom-MSA
- 12 October 2006: visit of T. Boutboul, L. Oberli to Alstom-MSA

NED steering committee meetings:

- 23 February 2006: steering meeting at CERN
CERN's participants: T. Boutboul, D. Leroy, L. Oberli, D. Richter
- 1 June 2006: steering meeting at Madrid
CERN's participants: T. Boutboul, L. Oberli
- 12 September 2005: steering meeting at CERN
CERN's participants: T. Boutboul, L. Oberli, C. Scheuerlein

Meetings on mechanical studies:

- 6 April 2006: meeting at CERN for discussing FE mechanical model for PIT wires
Participants: T. Boutboul, D. Leroy, L. Oberli, S. Farinon (INFN-Ge)
- 9 May 2006: meeting at CERN for discussing FE mechanical model for PIT wires
Participants: T. Boutboul, D. Leroy, L. Oberli, C. Scheuerlein, S. Farinon (INFN-Ge)
- 21 June 2006: meeting at CERN for discussing FE mechanical model for PIT wires
Participants: T. Boutboul, D. Leroy, L. Oberli, S. Farinon (INFN-Ge), A. Devred (CEA&CERN)
- 2 August 2006: meeting at CERN for discussing FE mechanical model for PIT wires
Participants: T. Boutboul, D. Leroy, L. Oberli, S. Farinon (INFN-Ge), A. Devred (CEA&CERN)
- 25 October 2006: meeting at CERN for discussing FE mechanical model for PIT and Alstom wires
Participants: T. Boutboul, D. Leroy, L. Oberli, S. Farinon (INFN-Ge), A. Devred (CEA&CERN)

3/ PUBLICATIONS

List of reports with CERN authors in CARE-NED

CARE/NED document	Title	Authors and Labs
ICEC 21/ICMC 06	Determination of mechanical properties of the individual phases in multifilamentary Nb ₃ Sn superconducting strands.	C. Scheuerlein and S. Sgobba (CERN), B. Rehmer, M. Griepentrog (BAM)
ASC 06	Nano and micro mechanical study of Nb ₃ Sn wires for the Next European Dipole (NED)	C. Scheuerlein and S. Sgobba (CERN), A. Devred (CEA&CERN), S. Farinon P. Fabbriatore (INFN-Ge)
ASC 06	Design and optimization of a cosθ cross-section for a high field dipole (NED)	N. Schwerg, D. Leroy, C. Vollinger (CERN) and A. Devred (CEA&CERN)
ASC 06	FE model to study the deformation of Nb ₃ Sn wires for the Next European Dipole (NED)	S. Farinon, P. Fabbriatore (INFN-Ge), A. Devred (CEA&CERN), T. Boutboul, D. Leroy, L. Oberli (CERN)
HHH meeting: WAMDO	Development of high critical current density Nb ₃ Sn strand in Europe for NED and CERN projects	L. Oberli (CERN)

4/ ACTIVITIES

Conductor development: status of SMI (NL)

During Step 1, SMI has reached a critical current density of 2410 A/mm² at 12 T on a strand sample of 1 mm in diameter drawn from the billet B179. For Step 2, it was decided to continue the development with a strand design for NED, a strand of 1.25 mm in diameter with 288 (NbTa)₃Sn filaments to get 50 μm filament diameter, by keeping the same NbTa tube and the same powder composition as for the billet B179 and by adjusting the filament layout to have more copper around the filaments. For Step 2, SMI produced two new billets with the final strand design. CERN has carried out an extensive program to characterize the strands. Virgin strand samples of the first 3 kg billet B207 were sent by CERN to LASA-Milano for critical current measurements. A high critical current value of 1313 A was measured at 12 T and 4.2 K on the samples which corresponds to a non-copper critical current density of 2069 A/mm². This lower than anticipated critical current density is attributed to a problem in the powder preparation which underwent by mistake an additional heat treatment. A RRR value of 250 was measured at CERN on a virgin sample of the billet B207 well above the specified NED value. To evaluate if the strands are capable to sustain cabling, the strands were deformed at CERN by rolling to investigate the filaments layout behaviour under different levels of deformation. The filament layout of the 3 kg billet has been able to sustain well the high unidirectional deformation as observed by optical metallography of the cross-section of the samples, confirming the importance to have enough copper around the filaments. A RRR value of 80 was measured at CERN on a sample deformed at a level of 28%. The critical current degradation due to flat deformation at a level of 28% was around 15%, which is still acceptable as we believe that the deformation due to flat rolling should be more drastic than cabling. A second 10 kg billet B215 was launched in fabrication by SMI, keeping the filament layout of the billet B207. A strand piece length of 900 m was obtained without any breakage. A high critical current of 1397 A was measured by Twente University at 12 T and 4.2 K thus only 15% below the 1636 A target value of the NED specification. This value corresponds to a non-copper critical current density of 2500 A/mm² and it is worthwhile to point out that this value was achieved in a strand with 50 μm filament diameter. Finally, rolling tests were carried out at CERN to study the wire sensitivity to deformation. The strand samples deformed with a 0.35 mm diameter reduction (deformation level of 28%) sustained well the deformation according to the cross-section of the samples observed at CERN by optical metallography. Critical current measurements performed at Twente University on samples flattened at the same level of deformation yield a degradation of 37% at 12 T and 4.2 K, although the deformed samples of

the billet B215 sustained the unidirectional deformation as well as the billet B207. The origin of this high degradation is under investigation. Cabling tests are foreseen to be done before end of 2006 at Berkeley National Laboratory. A 20 m long cable will be fabricated with the available 900 m strand piece length. The cabling tests have to prove the suitability of the SMI-NED strand for cabling.

Conductor development: status of ALSTOM-MSA(F)

For Alstom-MSA which develops the internal tin diffusion technology, Step 1 was devoted to study the influence of relevant parameters on workability and performances. For Step 1, Alstom-MSA has launched five different types of strands in fabrication with the aim to determine the optimum design in term of workability and critical current. All the sub-element billets have suffered from a too large number of breakages due to a lack of cohesion between the different components. The manufacturing process of the sub-element billet has been improved by Alstom-MSA which has produced a sub-element billet with a modified filament layout. A final billet making use of this new sub-element has been assembled with 78 sub-elements and has been drawn to 1.25 mm and 0.8 mm showing a very good workability. At a diameter of 0.8 mm, the sub-elements of the strand had a diameter of 50 μm , as requested for the NED strand. Strand samples were sent by CERN to LASA-Milano for critical current measurements. A critical current value of 740 A was measured at 12 T and 4.2 K on the samples which corresponds to a non-copper critical current density of 1500 A/mm². The non-copper critical current density achieved on the strand corresponds to the expected value as calculated by Alstom-MSA for this sub-element which has a large local Cu to Nb ratio. A sound sub-element design has been achieved by Alstom-MSA. This design is being used for Step 2 keeping a very similar filament layout but increasing the amount of Nb and decreasing the amount of Cu in order to reach at least a non-copper critical current density of 2500 A/mm² at 12 T and 4.2 K. The development plan for Step 2 was discussed in detail between CERN and Alstom-MSA. The decision was taken to launch in fabrication few billets with two different sub-element designs following a cold drawing process. In parallel, Alstom-MSA will also launch in fabrication a sub-element billet following a hot extrusion process. Alstom-MSA is focusing on the development on the manufacturing process of the final billet to switch from 78 to 246 sub-elements in order to get 50 μm sub-element diameter as required by the NED program. The first results of Step 2 are expected for the end of 2006. The completion of Step 2 is foreseen in June 2007.

Finite Element wire model to simulate cabling effects

To simulate the effect of cabling and derive optimum billet layout, INFN-Genova has build a Finite Element mechanical model of Nb₃Sn strands, with the aim of simulating the mechanical behaviour of a strand subjected to a severe plastic deformation. A plane strain 2D model was chosen as the strain value as measured at CERN along the longitudinal direction is 0.5 % for a 28 % reduction in diameter. The PIT-SMI strand deformed at few different reductions in diameter has been well simulated by the FE analysis. The calculations give a suitable description of the overall behaviour of the real strand. Different PIT strand designs were investigated with the aim to find an optimum design minimizing cabling damages. The FE analysis has confirmed the beneficial effect of increasing the local Cu to non-Cu area ratio. A strand layout with a large copper core obtained by removing 12 filaments around the core and by placing them on the external part of the filamentary region was simulated. A 30 % reduction of the Von Mises strain in the most deformed filaments was obtained. A model of the Alstom-MSA strand has been build and the first results of the simulation should be known before the end of 2006

5/ ACHIEVEMENTS

The main result so far has been the production by SMI of a NED wire having the required parameters and including 288 filaments. The wire achieved a record critical current of ~1400 A at 4.2 K and 12 T, corresponding to a critical current density of ~ 2500 A/mm² in the non copper part of the wire. Vigorous efforts were carried out by Alstom/MSA to develop the NED strand and a sound sub-element design has been obtained. Alstom/MSA has produced for Step 1 a wire with 78 sub-elements which achieved a critical current density of ~ 1500 A/mm² at 4.2 K and 12 T, thereby doubling the value achieved by Alstom/MSA before starting the NED-Program

2. DIRAC Secondary-Beams Design Study

1/ INTRODUCTION

For the EU design study “DIRAC Secondary-beams for the FAIR project” CERN is involved in 3 distinct sub-projects briefly described below:

Task 18 SIS100_2 regards the study of a Longitudinal Feedback System for the FAIR injector with possible hardware tests to be performed in the CERN PS ring.

Task 19 SIS100_3 is focused on the design and prototyping of a fast semi-conductor RF gap switch.

No deliverables were foreseen for the two tasks in 2006.

During 2006 studies were performed to prepare a set of specifications for the devices addressed by the two tasks and to better qualify the different requirements of GSI and CERN, with the aim of coming to a satisfactory synthesis.

Task 21 SIS 100_5 addresses the development of a novel digital signal processing system allowing to measure beam positions on a bunch by bunch and turn by turn basis. Similar systems measuring averaged orbits are available for electron accelerators. However the hadron version in which trajectories on single particle bunches can be followed during the complete acceleration cycle, constitutes a new development.

2/ MEETINGS

Meetings of tasks 18 and 19

Tele Conference 1 (30 March 2006)

A phone conference between representatives of CERN and GSI was held in March to discuss the evolution of the 2006 strategy for the two tasks. The conclusions have been the following.

Task 18 (Longitudinal feedback system):

- CERN contributes to this study providing examples of calculation of the bandwidth and amplitude requirements for previously developed longitudinal feedback systems.
- The Machine study session foreseen in July at CERN provides the real parameters for the damping of longitudinal coupled bunch instabilities in the CERN PS. Based on those results, GSI can investigate if the GSI hardware allows for the implementation of a specific algorithm that could be implemented in a feedback system.

Task 19 (Fast semiconductor gap switch):

- GSI has confidence that the MOSFET switch that they are presently testing is fit for installation in the SIS 18 bunch compression system. High power tests are required to confirm this expectation. On the other hand, the characteristics of this switch do not seem to allow their use on the CERN systems, since it could induce an unacceptable de-tuning of the cavities during operation at different power levels.
- One of these switches could be sent to CERN to allow specific hardware tests and the study of a possible compensation network.

Tele Conference 2 (28 September 2006)

A second phone conference between representatives of CERN and GSI was held in September to check the results obtained so far and to set the objectives until the end of 2006. The conclusions are the following:

Task 18 (Longitudinal feedback system):

- The requirements of a longitudinal feedback kicker capable of damping dipole and quadrupole modes seem to fit with the characteristics of the Finemet cavity which has been developed for

the LEIR project. An experiment based on a duplicate of the LEIR system is being considered to be performed at CERN or at GSI.

Task 19 (Fast semiconductor gap switch):

- The switch used at GSI for the high power tests is sent to CERN where a test bench will be prepared for performing specific studies on the 10 MHz spare cavity.

With a view to assess the radiation hardness of such a device, the possibility to perform specific tests during the 2007 machine run at CERN is considered.

Collaboration Meeting of Task 21

On 27-28 September a collaboration meeting was held at GSI in Darmstadt, Germany. Progress reports on the Libera Hardware and its firmware programming environment were presented by Instrumentation Technologies. It can be noted, that the milestone of having a finished and programmed hardware product after 15 months of development has been reached.

The GSI and CERN teams reported on progress achieved in the development of digital signal processing techniques that can be implemented in the FPGA.

3/ PUBLICATIONS

No publications have been issued during 2006. A presentation has been given at the 15 September session of the Accelerator Performance Committee at CERN (link to website: <http://ab-div.web.cern.ch/ab-div/Meetings/APC/Welcome.html>) on the studies on longitudinal coupled bunch instability performed on the CERN PS in July. The document can be consulted at:

<http://ab-div.web.cern.ch/ab-div/Meetings/APC/2006/apc060824/HD-APC-24-08-2006.pdf>

It is also intended to publish the beam-position measurement results collected in 2006 at CERN and GSI, in DIPAC (Diagnostics in Particle Accelerators), to be held in Mestre, Italy, in May 2007.

4/ ACTIVITIES

Task 18 SIS100_2

In task 18 (Longitudinal feedback system) a joint effort of CERN and GSI is in progress to develop effective simulation tools and to perform an accurate analysis of the data taken during the machine development study in July at CERN. In this framework, a measurement campaign has been planned to better characterize the 10 MHz cavity impedance to allow for a better comparison of measured data with simulations. A preliminary design for an RF wideband longitudinal kicker system will be prepared as soon as a coherent interpretation of the MD study is available.

Task 19 SIS100_3

Task 19 (Fast semiconductor gap switch) has been focused on the characterization of the Behlke switch that has been proposed for the SIS18 bunch compression system. Few contacts have been established with other companies or laboratories to check if different devices could be found on the market, but without any positive answer, until now. The proposal is to continue both activities during the next months and, at the same time, to check the applicability of the Behlke switch to the CERN systems. However, given the size and the weight of these devices, alternative solutions are also looked for at CERN.

Task 21 SIS100_5

Task 21 activities concern the system development, the tender for the system hardware and firmware and the measurement campaigns:

- ***System Development***

The digital signal processing algorithms developed in 2005 have been refined and implemented in VHDL to be programmed into the FPGA. First versions of the PLL Algorithm, the baseline restorer as well as the numeric integration algorithms have been completed and integrated with the firmware environment. This allowed us to make measurements with a first prototype on a single BPM installed in the PS accelerator.

During the 2005/2006 shutdown of CERN's accelerators the analogue front-end electronics has been replaced by more sensitive electronics. This allowed us to measure beam orbits of the low intensity ion beams coming from LEIR for the first time.

As a by-product of the BPM development, the prototype was used to acquire signals from the CERN PS injection transformer, which has similar requirements. The results are encouraging and it is intended to equip this transformer with numerical signal processing in the next year.

- ***Tender for the System Hardware and Firmware***

The tender for the final system hardware and firmware was completed in 2006 with a long delay. Due to this delay it will not be possible to finish all tests in the PS after 24 months of work as foreseen. A request to the EU has been made to prolong the project for 1 year within the approved budget.

- ***Measurement Campaigns***

Before the yearly shutdown of CERN's accelerators a series of measurements could be made, demonstrating the functionality of first implementations of the digital signal processing algorithms in the FPGA and their integration into the overall system. The CERN team was able to check correct operation of its digital PLL algorithm which allows us to follow individual bunches during the accelerating cycle. In low energy hadron machines the speed of the particle changes and so do the revolution and bunch frequencies. In order to perform numeric integration of the BPM signals, an integration gate following these changing frequencies must be created. It could be demonstrated that the PLL successfully locks onto the bunch frequency and that numerical integration worked correctly.

The GSI team follows a different bunch recognition strategy, in which the creation of the integration window depends on individual bunches. The GSI team came to CERN and tested its implementation on the PS on 13-14.9 2006.

Another measurement campaign is foreseen beginning of December, this time at the SIS18 at GSI in Darmstadt.

5/ ACHIEVEMENTS

For the two Tasks 18 and 19, no deliverables were foreseen in 2006. The most remarkable achievements are represented by the successful test at nominal power of the Behlke switch at GSI and the important set of measurements on longitudinal coupled bunch instabilities, which have been obtained at the CERN PS in July. Those data represent the basis on which the longitudinal feedback system is being designed and define the requirements for the design of the kicker system.

For the Task 21, the milestone for having a finished hardware module with the basic firmware installed has been reached in time. The delay in the completion of the tender for the final system hardware and firmware prevented to finish all the foreseen tests in the PS after 24 months and a request for a project extension at constant budget has been addressed to EU.

List of milestones and deliverables achieved in 2006 with CERN participation.

Deliverable/ Milestone	Deliverable/Milestone Name	Work- package No	Planned (in months)	Achieved (in months)
M	Hardware finished and programmed	1	15	15

3. EURISOL Design Study Activities

1/ INTRODUCTION

The EURISOL DS is aimed at producing feasibility studies and performing technical preparatory work of the most critical parts of the future EURISOL facility. The main technical challenges and the necessary prototyping were identified during the EURISOL RTD in the 5th framework (FP5). This design study is part of the roadmap towards the EURISOL facility and cross-fertilization is expected between the design study and the design and construction of the so-called "mid-term" facilities. A conceptual design study for an associated beta-beam facility, which can benefit from the prototyping work concerning the RIB facility, is an integral part of the DS proposal.

During 2006, the CERN contribution can be summarized as

- Leading 3 of the EURISOL tasks (Multi MW target station, direct targets and beta-beam)
- Organization of # task meetings
- Work with seven of twelve EURISOL tasks with published (internal and external) results
- Contributions to the management of EURISOL
- Contributions to management boards, steering committee meeting and coordination board meetings
- Contributions to task meetings

2/ MEETINGS

From 27/11/2006 to 30/11/2006, **Eurisol week 2006 TM-02**, Location: CERN

CERN contributions:

- Progress in the multi-MW target design studies, Yacine Kadi
- Multiple transfer lines for ISOL, Thierry Stora
- Production and bunching of RIBs for beta-beams, Pierre Delahaye

From 09/11/2006 to 10/11/2006, **Joint meeting Tasks 2, 3,4 and 5 JM-05**, Location: CERN

CERN contributions:

- Organizational questions, approval of proposed agenda, Yacine Kadi
- WP2: MW target, Yacine Kadi
- WP3: direct target, Thierry Stora

From 30/10/2006 to 30/10/2006, **4th beta-beam task meeting T12-04**, Location: CERN

CERN contributions:

- Welcome and introduction, M. Benedikt
- Intra Beam Scattering, A. Fabich
- PS2 activities at CERN, M. Benedikt
- Decay Ring RF aspects, S. Hancock
- Decay ring SC dipole design, E. Wildner
- Absorber design, layout and impedance, E. Wildner
- New proposals for ion production, M. Lindroos

From 16/10/2006 to 16/10/2006, **Management Board Meeting MB-12**, Location: CERN

From 12/10/2006 to 13/10/2006, **Joint Annual Meeting of SAFERIB & EURISOL-DS Task 5 T05-05**, Location: LMU, Munich, Germany

CERN contributions:

- WP3: Progress report, Luca Bruno

From 03/10/2006 to 04/10/2006, **MB and Task 2 and 4 Meeting MB-11**, Location: INFN-LNL

CERN contributions:

- Status of the multi MW target study, Yacine Kadi

From 12/09/2006 to 13/09/2006, **Management Team Meeting MB-10**, Location: LNL, Legnaro

From 04/09/2006 to 04/09/2006, **Task2-09-IPUL T02-09**, Location: IPUL, Riga, Latvia

CERN contributions:

- Management issues, Yacine Kadi
- Review CFD/FEM analysis of the window target design and system analysis of the Hg loop, Yacine Kadi

From 24/08/2006 to 30/08/2006, **NUFACT06**, Location: Irvine, USA

CERN contributions:

- Radioactive Ion Beams, A. Fabich
- Ion Losses and Collimation for the Betabeam Acceleration Scenario, A. Fabich
- Large Aperture Superconducting Dipoles for the Betabeam Decay Ring, E. Wildner
- A Low-Energy Accumulator and Cooling Ring for the Betabeam, M. Lindroos

From 25/08/2006 to 25/08/2006, **Task2-08-CERN T02-08**, Location: CERN

CERN contributions:

- Status of the multi MW target study, Yacine Kadi

From 31/07/2006 to 31/07/2006, **Management Board Meeting MB-09**, Location: London

From 13/07/2006 to 13/07/2006, **Task 11 meeting T11-06**, Location: GSI

CERN contributions:

- ST8: ISOLDE yield database, P. Delahaye

From 03/07/2006 to 07/07/2006, **Radioactive Nuclear Beams 2006**, Location: Cortina, Italy

From 26/06/2006 to 30/06/2006, **EPAC06**, Location: Edinburgh, UK

From 16/06/2006 to 16/06/2006, **Management Board Meeting MB-08**, Location: PSI

From 15/06/2006 to 15/06/2006, **CB Meeting CB-04**, Location: PSI

From 05/06/2006 to 06/06/2006, **T5-04-UW T05-04**, Location: UW, Warsaw, Poland

CERN contributions:

- WP5 and SAFERIB: progress reports, Thomas Otto

From 24/05/2006 to 24/05/2006, **Task 2-07-PSI T02-07**, Location: PSI

CERN contributions:

- Status of the multi MW target study, Yacine Kadi

From 22/05/2006 to 24/05/2006: **Charge Breeding workshop 06**, location: Darmstadt, Germany

CERN contributions:

- Study of different charge breeding techniques at ISOLDE, Pierre Delahaye

From 22/05/2006 to 22/05/2006, **Beta-beam task meeting T12-03**, Location: GSI, Darmstadt

CERN contributions:

- Introduction and Status, M. Benedikt
- Parameter list, E. Wildner
- Decay Ring stacking simulations, S. Hancock
- Decay Ring collimation and absorption, A. Fabich

From 05/05/2006 to 05/05/2006, **Benefits of Extended Capabilities of the Driver Accelerator JM-04**, Location: GSI

CERN contributions:

- Production targets for HI beams, J. Lettry and T. Stora
- Status of MultiMW converter, Y. Kadi and M. Lindroos

From 02/05/2006 to 02/05/2006, **Joint Meeting of Eurisol tasks 6,9 and 10 JM-03**, Location: Orsay, Paris

CERN contributions:

- Beta-beam requirements, A. Fabich

From 20/03/2006 to 21/03/2006, **Joint meeting Task 2, 3,4 and 5 - Legnaro JM-01**, Location:

Laboratori Nazionali di Legnaro

CERN contributions:

- Progress report on Task #2, Yacine Kadi
- Progress report on Task #3, Thierry Stora
- Progress report on WP5 at CERN, Marta Felcini
- Feasibility of refractory metal targets, Roman Wilfinger
- Feasibility of carbide targets, Liviu Pensescu
- Yields from different actinide targets (U vs Th), Yacine Kadi and Adonai Herrera-Martinez

From 02/03/2006 to 03/03/2006, **Management Board Meeting MB-07**, Location: CERN

From 01/02/2006 to 01/02/2006, **Task2-06-PSI T02-06**, Location: PSI

CERN contributions:

- Engineering Design of the Multi-MW target station, Yacine Kadi

3/ PUBLICATIONS

List of reports with CERN authors in EURISOL DS

EURISOL DS NOTE	Title	Authors and Labs
Task 2	EURISOL Multi-MW Target: Investigation of the hydrodynamics of liquid metal (Hg) jet	J. Freibergs et al., IPUL and CERN
Task2 PoS(FNDA2006)020	Radioactive Ion Beam Production by Fast-Neutron-Induced Fission in Actinide Targets at EURISOL, International Workshop on Fast Neutron Detectors University of Cape Town, South Africa, April 3 – 6, 2006	Y.Kadi and A.Herrera-Martinez, CERN
Task3	Feasibility study for the 100kW direct targets	T. Stora, J. Lettry, R. Catherall, E. Noah, R. Wilfinger, L. Penescu, E. Bouquerel, S. Fernandes, M. Santana-Leitner, L. Zanini, I. Guenter, F. Groeschel
Task3	W converter - BeO dual target prototype for ^6He production - a preliminary note	T. Stora, E. Bouquerel, J. Lettry
Task 3	Alkali suppression for pure Radioactive Ion Beam (RIB) production, In proceedings: Radioactive Nuclear Beams 7, Cortina, Italy	E. Bouquerel, R. Catherall, M. Eller, J. Lettry, S. Marzari, T. Stora
Task 3	TARPIPE: TARget Prototype Irradiations at PSI for EURISOL, In proceedings: Radioactive Nuclear Beams 7, Cortina, Italy	E. Bouquerel, R. Catherall, S. Fernandes, I. Guenther-Leopold, F. Groeschel, A. Kalt, J. Lettry, E. Manfrin, S. Marzari, E. Noah, T. Stora, R. Wilfinger, L. Zanini.
Task 3	First negative halogen beams produced at PSBooster-ISOLDE, In proceedings: Radioactive Nuclear Beams 7, Cortina, Italy	T. Stora, E. Bouquerel, R. Catherall, M. Eller, J. Lettry, M. Menna, R. Wilfinger
Task 3	Feasibility of High Power Refractory Metal Foil-Targets for EURISOL, In proceedings: Radioactive Nuclear Beams 7, Cortina, Italy	R. Wilfinger, J. Lettry
Task 3	Calculation of Production and Decay of Radio Isotopes for Future Irradiation Experiments and Ion Beam Facilities, In proceedings: Radioactive Nuclear Beams 7, Cortina, Italy	M. Eller, J. Lettry, R. Catherall, T. Stora
Task 5	Dose estimates and shielding design for the EURISOL facility, In proceedings: Radioactive Nuclear Beams 7, Cortina, Italy	Marta Felcini
Task 5/TN-06-07	Legal dispositions for transport, storage and use of special fissionable isotopes in Switzerland	Thomas Otto
Task 5/TN-06-01	Validation of FLUKA calculated cross-sections for radioisotope production in proton-on-target collisions at proton energies around 1GeV	M. Felcini, A. Ferrari
Task 12	Decay losses along the accelerator chain of the Beta-beam	A. Fabich and M. Benedikt
Task 12	Stacking simulations in the beta-beam decay ring	A. Chance (Saclay), S. Hancock (CERN)
Task 12	A low energy accumulation stage for a beta-beam facility	A. Kallberg (MSL), M. Lindroos (CERN) and A. Simonson (MSL)
Task 12	Estimation of decay losses and dynamic vacuum for the beta-beam accelerator chain	M. Benedikt, A. Fabich, E. Mahner, (CERN), M. Kirk, C. Omet, P. J. Spiller (GSI)

4/ ACTIVITIES

CERN participates in the following tasks:

Task 1, Management: The first annual report of the EURISOL DS was accepted by the EC without any remarks. On the technical side, the management has in 2006 adapted a baseline driver for the facility based on the results from the first year of work in the radioactive ion beam intensity task. The driver will be optimized for 1 GeV CW protons but with an extended capability for acceleration of Deuterium and Helium. On the scientific side, the management has assured that the web site came on-line which has increased the visibility of the study and improved the coordination of the work. The project leader, Graziano Fortuna, had to resign due to his appointment to the INFN executive board. Yorick Blumenfeld from IN2P3 at Orsay has been elected interim project leader, an appointment which the Steering Committee is expected to confirm in its regular meeting in November 2006. The spending within the study has been much lower than planned in the first year leading to a delay of the second prefinancement. The money for the second period will only be paid from the EC after the second annual report has been submitted.

Task 2, Multi MW target station: CERN is leading Task 2. The work on the multiMW converter unit is advancing as planned. Two layouts have been proposed, a more traditional neutron spallation target design of SNS type and a very promising compact and windowless design based on a new idea using flow guides to create a transversely flowing mercury converter. The first design has been chosen as the reference design and the second for a future upgrade. Detailed neutronic analysis of the reference design has been carried out on the converter and nearby structures. The energy deposition, n-flux distribution and spallation product yields have been studied together with radiation damage issues for the target vessel. Fission product yields and fissile inventory have been calculated for several target types at different locations around the Hg converter e.g. production of the beta-beam isotope ${}^6\text{He}$ from a BeO target. Furthermore, MonteCarlo calculations for waste production in the liquid Hg and in the fission target (spallation product distributions and build up of the fissile inventory) were performed for different incident proton energies, and actinide composition. Studies are in progress on the multiMW target in collaboration with the safety task to define the requirements for radiation protection of the target station and to propose options for the minimization of dose rates, activation, material handling and interventions, during and after operation. Integration studies of the fission target are presently being carried out in collaboration with the fission target task.

Task 3, Direct Target: CERN is leading Task 3. The direct target task is involved in the design of four so-called benchmark units, representative of the more than 100 different combinations of direct targets and ion sources to be operated at the EURISOL facility. The design is based on the validation of a set of numerical tools and tests of selected prototypes. Aspects related to their feasibility have been presented in a report, and there is good progress on their designs e.g. a solid converter/BeO dual target for the beta beam and a refractory metal foil benchmark target. In parallel, prototype designs and production for online tests is ongoing. The TARPIPE experiment will investigate target materials ageing under irradiation and it will receive protons at PSI starting Dec. 2006. A double transfer line target unit merging into a single ion source prototype has been assembled and it will be tested with protons at ISOLDE in April 2007.

Task 4, Fission target: Neutronic calculations for the first realistic multiMW target design with a mercury converter surrounded by UCx target units have been done. Benchmark calculations of different spallation models available in MCNPX2.5.0 and FLUKA have been performed for thin and thick targets. Production yields calculations with the FLUKA code have been performed to identify which fissile material gives better performances. Three kinds of materials were considered: ${}^{232}\text{ThC}_2$, ${}^{238}\text{UCx}$ and ${}^{\text{nat}}\text{UCx}$. The results show that already with two types (${}^{232}\text{ThC}_2$ and ${}^{\text{nat}}\text{UCx}$) the production requirements can be met. The integration of the complete target station with the mercury loop is now being studied.

Task 5, Safety and Radioprotection: In the report year, a shielding design for a MMW fission target, consisting of a neutron spallation source and a blanket of fissile material, was studied. Angular-dependent attenuation functions for different shielding materials were evaluated and a sandwich-structure made from iron and concrete was given as an example. From this work shielding guidelines for target stations in general were derived. The activity of the fission target, part of a MMW target station was estimated. Alpha-emitters are abundant in a target based on either ${}^{232}\text{Th}$ or ${}^{238}\text{U}$ and require safety mechanisms to ensure their enclosure at all times. Before being able to make detailed radiological assessments, dose factors for a significant number of radioactive isotopes present in ISOL-targets must be evaluated. These dose factors relate uptake of radionuclides to effective dose.

Present literature contains dose factors for radionuclides present in the nuclear fuel cycle, but not the more exotic, albeit long-lived species in an ISOL target. Evaluation of dose coefficients is out of the scope of the EURISOL project. The ^{238}U fission blanket of a MMW target will contain after its use a considerable amount of ^{239}Pu . Depending on the size of the target and the mass of ^{238}U employed, the amount will exceed the 150-gram threshold from when a facility falls under international safeguarding rules monitored by the IAEA. In Switzerland, EURISOL using a MMW fission target would be a “Nuclear Installation” under the authority of the Nuclear Inspectorate, in France it would be classified as an “Installation Nucléaire de Base (INB)”. In Italy, the use of ^{239}Pu in amounts exceeding a few grams cannot be licensed. The use of ^{232}Th as a fissile blanket would have the same consequences because of the breeding of ^{233}U .

Task 9, Beam Preparation: During the last period, a number of significant achievements have been done at ISOLDE for the study and comparison of the performances of the EBIS and ECR charge breeders. At REX-ISOLDE, a slow extraction scheme has been successfully implemented to allow for a longer radioactive beam pulse to be delivered to the experiments. New geometries of the electron gun for REX-EBIS have been studied using the EGUN code. A new electron gun has been constructed and mounted on REX-EBIS, using a segmented anode configuration (anode and post-anode). Very heavy isotopes such as ^{181}Ta and ^{238}U were charge bred with total REXTRAP and REXEBIS efficiencies up to 2.9 and to 4.3%. The injection and breaking-up of AIF molecules in REXTRAP prior to injection in the Phoenix ECR charge breeder setup has been consolidated to run at higher voltages, for making use of most of the beams produced at ISOLDE and delivered at 60kV. First order calculations of an energy and A/q separator have been realized, to reduce the stable background at the ECR charge breeder by suppressing the energy tails due to charge recombination in the extraction region. The parts of a separator bought from Lund University will be used for the final assembly, which is believed to occur in the coming year. The ISOLDE RFQ cooler off-line tests have started. Efficiency and beam emittance measurements are in progress. During these very preliminary tests, a maximum efficiency of 10% for continuous transmission could be obtained from a ^{133}Cs surface ionization source and in the absence of appropriate injection optics. It is expected that this efficiency will be greatly enhanced in December 2006 by the installation of a quadrupole triplet. The 2σ rms emittance of the continuous cold beam has been measured at 30keV to be less than 5π .mm.mrad. The progresses are according to the expectations.

Task 11, Beam Intensity Calculations: A compilation of the latest yield measurements at ISOLDE for various isotopes and target-ion source units has been released and is now available in the new ISOLDE database at the following address: http://oraweb.cern.ch:9000/pls/isolde/query_tgt. This database makes use of the functionalities of the Oracle software. It is now easier to consult and to update via a Java interface. The work related to the milestone M7.2, the “extrapolation of measured release-efficiency data” is in progress. This milestone is strongly bound to the progresses made in the Task 3, for the design of the new 100kW target ion-source units. Recently, new geometries were defined for solid target units, and molten lead units. Very little is known for what is concerning the effusion/diffusion processes, and therefore the release efficiencies. More data should be available from Task 3 in the coming months, especially from on-line tests of prototypes. This milestone is closely related to the ultimate deliverable of the Task 11: the prediction of secondary beam intensities. Lately, the use of the ABRABLA code, together with a simple parametrization of the release efficiency as a function of the isotope half-life, could satisfactorily reproduce most of the yields quoted in the ISOLDE database for different tested target and ion source combinations (see former report - GSI team). This result gives the chance to find a global approach for extrapolating the release efficiencies, by extrapolating the parametrizations for the new target and ion source units. Because this extrapolation requires additional input from Task 3, and since the compilation of the new parametrizations will take time and is not required before, it has been proposed to postpone the milestone M7.2 to the month 33.

Task 12, Beta Beam Aspect: CERN is leading the EURISOL Task 12. The task is performing a Conceptual Design Study (CDS) for the accelerator chain of the EURISOL beta-beam facility. After defining the machines cycles of PS and SPS and estimating beam losses due to particle decay, the use of the existing PS and SPS machines for beta-beam purposes was investigated further in detail by finalizing the dynamic vacuum simulations (in collaboration with GSI) and performing studies on emittance growth due to IBS. The RF system requirements throughout the whole beta-beam accelerator chain have been studied for matching and acceleration cycles. The possible replacement of the PS machine was included in the CDS, also reflected in changing the baseline parameter of the RCS

ejection energy to 3.5 GeV proton equivalent. The decay ring layout was studied for the details of the injection layout and merging process, the aperture layout including absorber positioning, collimation aspects, super-conducting dipole design, RF requirements and impedance issues.

5/ ACHIEVEMENTS

A list of milestones and deliverables achieved can be seen in this table.

Task	Deliverable/ Milestone	Deliverable/Milestone Name	Work- package	Planned (in months)	Achieved (in months)
Task 2	M1.2	Report on the evaluation of the windowless configuration feasibility	Sub-task#1	9	22
Task 2	M1.3	Preliminary Design Report	Sub-task#1	14	24
Task 2	M5.1	Status Report on the design of the target enclosure and the front end	Sub-task#5	28	24
Task 2	M5.2	Status Report	Sub-task#5	36	24
Task 2	M5.3	Status Report on the integration of the secondary fission target	Sub-task#5	44	24
Task 3	M1.1	Feasibility of carbide target	1	13	16
Task 3	M2.1	Feasibility of metal foil target	2	13	16
Task 3	M3.1	Feasibility of oxide target	3	13	16
Task 3	M4.1	Feasibility of molten metal target	4	13	16
Task 3	M2.2	Design of metal foil target	2	16	19
Task 3	M3.2b	Design of oxide target (converter)	3	15	20
Task 3	M2.3	Test on prototype of metal foil target at ISOLDE-PSI → TARPIPE		20	22 (start)
Task 3	M1.2	Design of carbide target	1	16	
Task 3	M3.2a	Design of oxide target	3	15	
Task 5	M1.2	Radiation and Activation estimates		18	18
Task 5	M 1.3	Shielding guidelines		22	22
Task 11	M7.1	ISOLDE database completion	8	12	12
Task 12	M2.2	RCS - First order optics design	2	18	15
Task 12	M3.2	Identification of PS and SPS limitations	3	18	17
Task 12	M4.2	Decay ring - First order optics design	4	18	14

4. EURONS Joint Research and Transnational Access Activities (I3)

1/ INTRODUCTION

Since January 1st 2005 CERN-PH-ISOLDE is via the EURONS activity engaged in the transnational access program as well as in several Joint Research Activities (JRAs) within the sixth framework programme of the European Union. The transnational access programme (TA8) provides financial support for the participation of users in experiments, user support in the form of physics expertise for users of the facility and administrative support for user activities. The JRAs are as follows:

CHARGE BREEDING (J03): The project aims at narrowing charge state distributions from charge breeders, to optimize beam purification, to compare breeding measurements from both ECR and EBIS sources and to optimize the transverse and longitudinal emittance of the extracted beams.

INTAG (J06): The goal is the study of exotic nuclei, including heavy nuclei, which are identified by electromagnetic separation and/or by observing the characteristics of their radioactive decays in the focal plane of separators. Webpage: <http://www.Inl.infn.it/~intag/>.

ISIBHI(J07): The objective is to develop ion sources for intense beams.

LASER (J08): The objective is to develop tools and perform R&D for the Resonance Ionization Laser Ion Source (RILIS) in order to produce pure ground-state and isomeric beams of exotic nuclei, to develop in-source laser spectroscopy of short-lived nuclei and to accumulate, cool, bunch and polarize radioactive ion beams.

SAFERIB (J10): Addresses safety aspects of RIB production targets.

TRAPSPEC (J11): Aims at designing multi-purpose set-ups for precision experiments in decay spectroscopy which combine ion traps and detectors as well as the development of retardation spectrometers for high-resolution and precision recoil ion spectroscopy.

2/ MEETINGS

2.1 General

EURONS, Project Coordination Committee (PCC) meeting, Mainz, 6-7 April 2006

EURONS, PCC and General Assembly meeting, Groningen, 11-12 December 2006

2.2 Transnational Access related

ISOLDE workshop and Users Meeting, CERN, Feb. 6-8, 2006

The meeting provided the opportunity for a yearly follow up of the physics results from ISOLDE in the form of presentations given by external physicists. Local physicists provided information on the current status of the machines and future plans. The organisation committee for the meeting was chaired by the physics group leader and the program organised by the local EURONS co-ordinator. Administrative support for the meeting was also provided by ISOLDE within the EURONS framework. Local organizers, K. Riisager, J. Cederkall, J. Weterings. L. Fraile, M. Lindroos.

Nuclei in the Cosmos IX Summer School, CERN, June 20-25, 2006

A summer school for young physicists in nuclear astrophysics and astrophysics was organised at ISOLDE in 2006. The organisation was chaired by the local EURONS co-ordinator. The activity was partly intended to provide training for potential new users of the facility in accordance with the long term planning for the physics program. Local organizers, J. Cederkall.

2.3 JRA related

CHARGE BREEDING

Charge Breeding workshop 06, Darmstadt, Germany, May 22-24, 2006.

One participant related to EURONS and EURISOL. Presentation of the latest results obtained with REXEBIS and the Phoenix booster on studies of different charge breeding techniques at ISOLDE.

INTAG:

INTAG meeting, CERN, January 23, 2006

(Telephone- and Video-conference meetings)

INTAG meeting, LNL (Italy), 26 May 2006

Recoil Separator meeting, Leuven (Belgium), June 21, 2006

The aim of this meeting was to establish a collaboration working towards the commissioning of a new Vacuum Mode Recoil Separator after REX-ISOLDE and its subsequent physics exploitation. The collaboration provides a strong supporting case for funding HIE-ISOLDE. A European consortium exploring possible synergies between the proposed vacuum mode separator projects at CERN and JYFL (Jyvaskylo University, FL) was proposed. A Letter of intent submitted to the INTC and application for funds will start 2007. A physics workshop discussing new physics using the vacuum mode recoil separator will be held in Munich in the spring 2007.

ISIBHI:

3rd technical meeting at CERN, March 8-9, 2006

4th technical meeting in Uppsala, Sweden, October 18-19, 2006

LASER:

Laser steering committee meeting, Poznan, Poland, May 29 – June 1, 2006

The meeting took place at the workshop on “Applications of Lasers in Atomic Nuclear Research”.

TRAPSPEC:

TRAPSPEC business meeting in Leuven, Belgium, September 18-19, 2006

3/PUBLICATIONS

For the Transnational Access, publications relevant to the activity are scientific papers published by users. These are not given here.

CHARGE BREEDING:

- Recent results with the Phoenix booster at ISOLDE
P. Delahaye et al, Rev. Sci. Instrum. 77, 03B105(2006)
- The REX-ISOLDE charge breeder as an operational machine
F. Wenander et al, Rev. Sci. Instrum. 77, 03B104(2006)
- Electron Gun Design for Improved Electron Optics at the REXEBIS Charge Breeder, Klaus Allinger, Diploma thesis, LMU Munich, defended May 2006.

ISIBHI:

- MS-ECRIS, the European roadmap to the 3rd generation ECR ion sources,
G. Ciavola et al. Accepted for publication in Rev. Sci. Instrum.
- Status report of the MS-ECRIS construction, presented at the ECRIS06 (Lanzhou/China), G. Ciavola et al.

LASER:

- Development of an Ionization Scheme for Gold using the Selective Laser Ion Source at the On-Line Isotope Separator ISOLDE. V.N. Fedosseev, P. Kosuri, B.A. Marsh - CERN-AB-Note-2006-016 ATB, March 2006.
- Development of a RILIS Ionisation Scheme for Gold at ISOLDE, CERN. V.N. Fedosseev, P. Kosuri, B.A. Marsh - Hyperfine Interactions, in print.

TRAPSPEC:

- Towards high-accuracy mass spectrometry of highly charged short-lived ions at ISOLTRAP. A. Herlert, S. Baruah, K. Blaum, P. Delahaye, M. Dworschak, S. George, C. Guénaut, U. Hager, F. Herfurth, A. Kellerbauer, M. Marie-Jeanne, S. Schwarz, L. Schweikhard, C. Yazidjian. *Int. J. Mass Spectrom.* 251, 131-137 (2006)
- High-precision mass measurements for reliable nuclear astrophysics calculations. A. Herlert, S. Baruah, K. Blaum, M. Breitenfeldt, P. Delahaye, M. Dworschak, S. George, C. Guénaut, U. Hager, F. Herfurth, A. Kellerbauer, H.-J. Kluge, D. Lunney, R. Savreux, S. Schwarz, L. Schweikhard, C. Yazidjian. *Proceedings of the International Symposium on Nuclear Astrophysics - Nuclei in the Cosmos – IX*, CERN, Geneva, Switzerland, June 25-30, 2006 PoS(NIC-IX)051 (2006)

4/ ACTIVITIES

For the transnational access, four meetings of the user selection panel have taken place as updates of the facility schedule have become available. The user workshop and a school for young physicists were organized during the year. Activities in relation to users include support for the physics program as well as user administration. These activities occur on a daily basis.

CHARGE BREEDING:

Various activities have been undertaken at ISOLDE for the study of advanced charge breeding methods, with both REXEBIS and the Phoenix ECR charge breeder during the period.

Subtask: New electron gun design

New geometries of the electron gun for REX-EBIS have been studied using the EGUN code, either to improve the electron optical beam quality or to increase the current and current density. A new electron gun has been constructed and mounted on REX-EBIS, using a segmented anode configuration (anode and post-anode). Tests are under progress.

Subtask: Beam purity improvements

The injection and breaking-up of AlF molecules in REXTRAP prior to injection into REXEBIS has been shown to be an efficient way of extracting pure beams of Al. Up to 16.7% total trap and EBIS efficiency was obtained for Al⁷⁺. A mass selective cooling method is being tested at REXTRAP, for a purification of the beam prior to its injection into REXEBIS. First order calculations of an energy and A/q separator have been realized, to reduce the stable background at the ECR charge breeder by suppressing the energy tails due to charge recombination in the extraction region.

INTAG:

Subtask: Magnetic pre-selection

The RFQ cooler has been mounted in a test bench where vacuum, mechanics, power supplies, controls have been commissioned. First injection tests on the RFQ cooler have taken place since summer 2006. Cooling and emittance measurements are underway. A fellow has been hired to work on the design of a new ISOLDE-HRS separator. She will start 1 January 2007.

Subtask: Tests with target detector

The Warsaw group has developed a new version of GOSIA, GOSIA2. Apart from having an improved user interface it features a simultaneous treatment of projectile and target excitation to provide internal normalization. This is of great interest for REX-ISOLDE experiments. Development work for a Bragg Spectrometer for use after REX-ISOLDE is currently carried out at the participating universities in York and Munich.

Subtask: Magnetic separator design

A meeting was held to establish collaboration for the construction and installation recoil separator after REX-ISOLDE.

ISIBHI:

The main activities at the moment are the purchase of the mechanical components, the follow-up of the construction of the superconducting magnets, the refurbishment of the 28GHz gyrotron and the preparation of the test stand at GSI. In parallel there are activities for the oven and beam diagnostics development.

LASER:

The off-line tests with different cavity material are only partially reached in time. A quartz covered line has been tested successfully on-line. The delay in testing other materials is due to limited accessibility of the on-line ISOLDE separator. At the Mainz off-line separator an ISOLDE target will be set up (target unit will be delivered by CERN) and a set of cavities of different materials (carbides and others) will be delivered by CERN to be tested at Mainz. Similar test are foreseen at the ALTO laser ion source at IPN Orsay, once the laser system is installed. Coordination (ISOLDE, Mainz, Orsay) between the three groups will be needed. In this way the milestones will be reached before the end of the project.

SAFERIB:

Members of CERN's RP group are currently studying the production of alpha emitters in heavy ISOL targets, predominantly actinide targets. Alpha emitters have a high radiotoxicity and are the radiologically most dangerous radionuclides once a spent target is dismantled for final waste storage. The aim of the work is to estimate the radiological hazard that spent ISOL targets present for personnel and the environment under routine and accident conditions. The work is still in progress.

TRAPSPEC:

LabView control system updated and software adopted for the in-trap decay method. Further efficiency tests and simulations of the CDEM detector have been done. The CDEM detector has been regularly used throughout the 2006 on-line period at ISOLDE/CERN. First mass measurement of radionuclides that have been produced by in-trap decay at ISOLTRAP. The masses of neutron-rich iron nuclides ($A=61-63$) were determined. These Fe nuclides are not delivered from the ISOLDE facility. They were produced and stored at ISOLTRAP after the decay of trapped short-lived Mn nuclides (initially produced at the ISOLDE target and ionized with a RILIS ion source).

5/ ACHIEVEMENTS

5.1 Transnational access related

Milestones and deliverables achieved during 2006 with target months:

M-TA08-1.4 Call for users – 03/06, achieved 02/06

M-TA08-1.5 Meeting of user selection panel – 04/06, achieved 10/06 (several meetings held)

D-TA08-1.1 Access report 2006 – 01/06, achieved 01/06

5.2 JRA related

Milestones and deliverables achieved during 2006 with target months:

CHARGE BREEDING:

M-J03-1.1 New gun design for REXEBIS – 04/06, achieved 04/06

M-J03-5.3 Purification of beams from REXEBIS – 12/07, achieved 09/06

D-J03-1.2 New gun for REXEBIS – 04/06, achieved 04/06

INTAG:

M-J06-2.1 Design of upgrade of HRS – 06/06, delayed due to late start of postdoc

LASER:

M-J08-2.1 New laser ionization schemes tested with stable isotopes – 01/06, achieved 01/06

M-J08-4.1 Off-line test with different cavity materials – 06/06, partially achieved (see above)

TRAPSPEC:

M-J11-4.2 Software development for in-trap decay – 03/06, achieved in 2005

M-J11-4.3 Test of CDEM detector – 12/06, achieved in 2005

M-J11-4.4 Specification of the in-trap decay method – 12/08, achieved 08/06

5. EUROTTeV Design Study Activities

1/ INTRODUCTION

The design study EUROTTeV addresses R&D issues common to the ILC and CLIC. It started 1st January 2005 and will end 31st December 2007; currently it is discussed whether the study should be extended into 2008. The main milestone foreseen in 2006 has been a general EUROTTeV meeting to review the status of the technical progress; this meeting has been moved to January 2007.

CERN is participating in the workpackages addressing the damping ring, the beam delivery system, the instrumentation and the luminosity performance; CERN also contributes to the management by providing one of the two scientific coordinators and the leader of the beam dynamics work-package (ILPS).

2/ MEETINGS

In 2006 only one specific EUROTTeV meeting has been held, namely the

EUROTTeV Workshop, Paris (June 2006) The aim of the workshop was to review the workpackage status and to take corrective action where necessary.

In addition, the CLIC beam physics work has been coordinated by beam physics meetings at CERN and by visits of our collaborators. The ILC beam physics work has been coordinated mainly by video meetings within the GDE, organised by the ILPS coordinator D. Schulte and K. Kubo (KEK) and by face-to-face meetings in CERN, Bangalore, Vancouver and Valencia. Larger meetings organized by CERN have been

CLIC LET Workshop, CERN (February 2006) To review the status of the CLIC beam physics studies on Low Emittance Transport (LET) and foster information exchange with our external collaborators

ILC LET Workshop, CERN (February 2006) To review the status of the ILC beam physics studies on LET and foster information exchange with the international collaborators

3/ PUBLICATIONS

The work for EUROTTeV has been documented in a number of publications. The EUROTTeV reports and memos are listed in the Table on next page.

Reports	Title	Authors
2005-027	Alternative Optics Design: Nonlinear Collimation System	A. Faus-Golfe et al.
2006-002	Electron Cloud in Wigglers.	F. Zimmermann et al.
2006-005	Aims and initial progress of TPMON task	A. Andersson, J. P. H. Sladen
2006-026	Effects of Wake Fields in the CLIC BDS	G. Rumolo et al.
2006-027	CLIC Final Focus Studies	R. Tomas et al.
2006-028	Halo and Tail Generation Studies for LC	H. Burkhardt et al.
2006-029	Faktor 2: A Code to Simulate Collective Effects of Electrons and Ions	W. Bruns et al.
2006-030	Recent Improvements of PLACET	A. Latina et al.
2006-031	Implications of a Curved Tunnel for the Main Linac of CLIC	A. Latina et al.
2006-032	Ion Effects in Damping Rings of ILC and CLIC	F. Zimmermann et al.
2006-039	Luminosity Tuning at the Interaction Point	P. Eliasson et al.
2006-040	A Study of Failure Modes in the ILC Main Linac	P. Eliasson et al.
2006-050	Study of an ILC Main Linac that Follows the Earth Curvature	D. Schulte et al.
2006-064	Non-linear Collimation in Linear and Circular Colliders	A. Faus-Golfe et al.
2006-065	Precision Beam Timing Measurement System for CLIC Synchronization	A. Andersson, J. P. H. Sladen
2006-070	Simulation of the Electron Cloud for Various Configurations of a Damping Ring for the ILC	A. Wolski et al.
In review	Design and Simulation of the ILC Intra-train Orbit and Luminosity Feedback Systems	G. White et al.
2006-092	Efficient Collimation and Machine Protection for the Compact Linear Collider	R. Assmann, F. Zimmermann
2006-099	Optimum Frequency and Gradient for the CLIC Main Linac	A. Grudiev, D. Schulte, W. Wuensch
In review	A Structure for a Wide Band Wall Current Monitor	T. Kroyer
Memos		
2006-001-0	A Program to Simulate Ground Motion	D. Schulte

4/ ACTIVITIES

The hardware tasks in which CERN is involved are under CERN sole responsibility and are thus coordinated by the task leaders.

Resources

All the foreseen five fellow positions had been filled in 2005. The spending on hardware had been delayed for two tasks in the BDI group (PBPM and WBCM) due to the unavailability of human resources. While for one of the tasks (PBPM) a solution had been found in 2005 this was not the case for the other (WBCM). For this task one person year to be provided by CERN was missing. Since it has not been possible to hire an associate to compensate this, it was agreed to support an additional fellow from the EU contribution to EUROTeV for one year. With this measure it should be possible to achieve the task still before the end of the project. The increased spending is compensated by additional resources that become available in the AB department due to fellows leaving early in 2006.

Beam Delivery System

BDSL D (Beam Delivery System Design)

The CLIC beam delivery system has been very significantly improved by optimizing the strength of the different components. This has been achieved by using a multi-dimensional optimisation routine to minimize the beam size at the collision. It yielded an increase in luminosity of about 40% for the same beam current.

Tuning knobs for the beam delivery system have been developed and their performance tested.

SWMD (Mechanical Spoiler System)

Together with the workpackage on integrated luminosity performance studies, routines have been developed that can calculate the geometric and resistive wakefields of collimators. These routines have been implemented into PLACET and the impact of the wakefields on the luminosity performance has been studied.

Damping Rings

ECLLOUD (Electron Cloud and Fast Beam Ion Instability)

The electron cloud build-up in DAFNE has been simulated at CERN using field maps provided by LNF. The results need to be compared to the measurements by LNF.

The model parameters for the simulation have been updated based on results of the benchmarking at SPS performed at CERN.

A new electron cloud code has been developed that allows arbitrary boundary conditions and inclusion of the effect of ions.

Several measures to reduce the electron cloud effect are currently under study. One possibility is to use clearing electrodes. The impedance of such electrodes has been studied at CERN using the code GdfidL. Another measure is the use of grooved surfaces. The new code has been used to study their impact showing a significant reduction.

The instability thresholds have been studied in collaboration with M. Pivi and K. Ohmi using the CERN code HEADTAIL.

Diagnostics

TPMON (Precision Phase Reference)

The objective of the task is to build the electronics for a high precision RF-based bunch timing measurement system and test it with beam. The phase of a bunch train will be measured at 30GHz with the aim to approach an accuracy of 10fs for a single-shot wideband measurement. It will consist of a 30GHz front-end followed by a 750MHz phase detector and a data acquisition system.

The work of the previous year on a suitable wideband phase detector continued and a printed circuit board version has been completed successfully. It contains 8 phase detector integrated circuits in parallel with their outputs summed. Laboratory tests have shown that this meets our noise and bandwidth requirements.

The front-end has been designed and all components ordered. The local oscillator multiplication noise has been measured to be 4fs which is acceptable for the system. A prototype can be completed after delivery of the final components. These are due by 1st November 2006.

A 10-bit 2GB/s data acquisition system has been purchased. It has been used for laboratory characterization of phase detectors and is ideally suited for tests of the complete system with beam. The first of these tests are planned for November 2006 in CTF3.

WBCM (Wide Band Current Monitor)

The objective of the task is to develop a wide band current monitor for CLIC based on an existing design that shows a bandwidth limitation. In order to overcome the missing CERN staff an additional fellow has been hired on EU funds for this task. At the beginning of the year a mini-workshop with CERN RF experts was held. This led to the proposal of several new structures. This year the existing structure has been measured and simulated with help of the RF group to identify the origin of the bandwidth limitation. Even though the bandwidth of the test bench was shown to be insufficient, the analysis of the frequency measurements is in agreement with the bandwidth calculated from previous time domain measurements. A new test bench is presently being manufactured and should enable more conclusive measurement on the existing WBCM.

The newly proposed structures have been simulated. One of them, a coaxial structure where the longitudinal gap is eliminated and replaced by a tapering section, has been retained as the best candidate. It has also been identified that the number of pick-up antennas around the circumference must be increased from eight to sixteen, in order to avoid circumferential resonances within the 20GHz bandwidth. Simulations, which include real microwave absorbers and ferrites, in order to predict the real behavior of the structure, are presently being carried out by the new fellow who was

hired as from 1st of September. The aim is to arrive at a 3D design by the end of the year. It is hoped that beam test will be still possible in September next year.

PTBPM (Precision Beam Position Monitor)

The project of design and construction of a Precision Beam Position Monitor, with 6 mm aperture and 100nm resolution is going ahead as planned. All the electrical parameters were studied using the simulation codes HFSS, Microwave Studio and PSPICE. After evaluation of the results, a 3D design was obtained in July. The fabrication drawings were finalized in September and the manufacturing of one prototype has been launched. The design of a high resolution test bench has also progressed and the main parts are ordered. The design of the front-end electronics is not yet finalized, but a prototype is foreseen to be ready for the first bench tests in December 2006. A EUROTev report detailing the status of the project has been published in October 2006. The prototype tests are planned for September 2007.

Integrated Luminosity Performance Studies

The work-package is led by CERN. It has been organized by GDE meetings for the ILC part and by CERN meetings for the CLIC part, as mentioned in the meeting section.

COLSIM (Collimation Simulations)

The new non-linear CLIC collimation system has been systematically studied, in particular the trade-off luminosity performance versus damage potential at the collimators. Detailed studies of the collimation efficiency of the linear and non-linear system show that the performance is comparable. However, it has been found that the non-linear system is not superior to the linear one.

FMSIM (Failure Mode Simulations)

Failure modes of the ILC have been studied to compare to results obtained at DESY. Good agreement has been found and the results documented.

LAST (Luminosity and Alignment Study Task)

The CERN beam dynamics simulation code PLACET has been significantly developed. Six dimensional tracking has been introduced that allows to extend the simulations also to the bunch compressor region. An interface to OCTAVE has been generated. OCTAVE is a MATLAB-like program and has very rich mathematical tools; the combination of the two codes will allow for faster development of algorithms. A new feedback type has been introduced to the code that is based on the so-called MICADO method of alignment. It allows to achieve full correction in a slow feedback style mode. The internal structure of the code has significantly been improved by more consistently using object oriented methods. This also led to a significant improvement of the simulation speed by 33%. The new tracking module can track a beam on a number of CPUs in parallel in order to reduce the turn-around time for the simulations. Further effort should allow to extend this capability to all beam line elements.

In the framework of the ILC-GDE, different tracking codes have been compared. Excellent agreement has been achieved, giving confidence in PLACET. Further the performance of the beam-based alignment procedures have also been compared for similar approaches. Good agreement has been found, which counteracts claims from the beginning of the year that PLACET was predicting to optimistic performances.

Dispersion free steering in the main linac requires beams of different energy. At the beginning of the linac this is difficult to achieve. Last year we proposed to vary the RF voltage of the bunch compressor for this purpose. Simulation studies showed this year that indeed that method is effective. It was found to be even more efficient than to (artificially) modify the incoming beam energy. The impact of the longer bunches that result from the modified compressor voltage could be tracked down.

The emittance tuning bumps have been further developed. It has been possible to make the different bumps orthogonal, which results in a faster achievement of the optimum performance.

The impact of a tunnel following the earth curvature has been studied in detail both for ILC and CLIC. While such a solution seems prohibitive it leads to some degradation of the performance. The main problem of a non-straight tunnel is that the beam needs to have dispersion in the beam position monitors in order to be guided around the earth. Hence, the different energy test beams need to have a different trajectories than the nominal beam, making the scheme vulnerable to errors in the beam position monitor calibration; in a laser straight tunnel these effects can be mitigated by simply iterating the alignment procedure.

Realistic tuning knobs have been developed for the CLIC beam delivery system and the optimization of these knobs has been studied for a stable machine. Results look very promising.

The study of the impact of dynamic imperfections on the beam-based alignment procedures has started. First results indicate the negative effects can be mitigated.

The impact of a changed gradient on the beam dynamics in the CLIC main linac has been studied. This was important for the overall CLIC parameter optimization.

HTGEN (Halo and Tail Generation)

A comprehensive list of candidate processes was established. Simulation code for the most important processes, the beam-gas scattering with the Mott and Bremstrahlung processes has been written, made generally available on the web and been implemented into the tracking code PLACET. An interface to another code MERLIN has also been provided. The capability to track secondary photons and to detect loss of beam particles and photons in the different beam line elements has been added to PLACET. First applications and results for CLIC and ILC have been presented and documented.

Studies on increase of halo and tail amplitudes by misalignment and multipole errors have started.

A new fast and very precise direct synchrotron radiation spectrum generator has been implemented in GEANT4. It is now part of the standard GEANT4 code and documented in the physics manual.

The task is in close contact with other EuroTeV tasks and the status of CERN work was discussed.

Recently, the EuroTeV fellow Lionel Neukermans, spent a week at the Daresbury to directly collaborate with our colleagues working on the collimation design for the ILC.

BBSIM (Beam-Beam Simulations)

The task to benchmark and improve the beam-beam simulation code GUINEA-PIG is mainly based at LAL. It has been supported with advice by the original author of the code at CERN. The focus has been to study the impact of beam-beam effects on the luminosity spectrum reconstruction, which has been found to be potentially significant. Last years benchmarking results have been published.

5/ ACHIEVEMENTS

Essentially all tasks are progressing as foreseen. Last year the two main problems have been the precision BPM and wide band current monitor tasks. The resources for the former have been made available from the beginning of 2006, and the task has been progressing well since. For the wide band current monitor a solution has been found in 2006 to compensate the missing CERN personnel. While this task is late it seems possible to still finish it in time.

Specific achievements of CERN in the EUROTeV programme in 2006 were

- The optimisation of the CLIC beam delivery system yielded a 40% increase in luminosity.
- The new electron cloud simulation code is functional and has been used to obtain first results.
- The precision phase measurement system has been designed. The critical local oscillators have been tested and found to deliver adequate precision. The necessary parts to build the full prototype have been ordered.
- The precision BPM has been designed and simulated. A prototype has been ordered.
- A technical solution for the wide band current monitor has been found and simulated. The design for ordering a prototype is being made.
- The design of the non-linear collimation system has been investigated showing a performance comparable to the linear system but not superior.

- Different main linac tracking codes have been benchmarked against each other including the effect of the beam-based alignment procedure. The very good agreement gives confidence in the CERN code PLACET.
- Simulations of the emittance preservation in a main linac tunnel following the earth curvature have been performed for CLIC and ILC.
- A solution has been found for the alignment of the first part of the main linac by dispersion free steering. The bunch compressor can be used to provide beams of different energies.
- The tracking code PLACET has been significantly improved by implementing longitudinal motion to allow simulation of the bunch compressors. Also the potential to track a beam in parallel on a cluster of computers has been implemented. In addition collimator wake-fields and the potential to simulate the generation of halo has been added; it is now possible to track secondary photons and to identify where losses of halo or photons occur.

6. Financial Report

CARE EU PROJECT - BUDGET OVERVIEW

	EUROS (€)	DURATION
EU Maximum contribution for CERN	2,755,300	01.01.2004 to 31.12.08
CERN received Payment 1	1,069,328	
CERN received Payment 2	1,117,320	
CERN received Payment 3	400,000	
Total received	2,586,648	

CERN, to be received	168,652
-----------------------------	----------------

EU Budget (in KCHF)			
Project activities	Total budget allocation	Budget used up to 31 Oct. 2006 ⁽¹⁾	% used
ELAN	158	67	42%
BENE	89	43	48%
HHH	283	149	53%
PHIN	1,826	1,430	78%
HIPPI	984	502	51%
NED ⁽²⁾	930	922	99%
Total	4,270	3,113	73%

CERN Budget (in KCHF)			
Project activities	Total budget allocation	Budget used up to 31 Oct. 2006 ⁽¹⁾	% used
ELAN	633	357	56%
BENE	660	266	40%
HHH	2,420	1,475	61%
PHIN	2,081	1,618	78%
HIPPI	8,624	4,722	55%
NED	379	317	84%
Total	14,977	8,755	59%

TOTAL EU+CERN Budget	19,067	11,868	62%
-----------------------------	---------------	---------------	------------

(1) Including expenditure (G.Guignard estimates) not charged to the CARE project's specific budget codes (mainly personnel costs for CERN part)

(2) NED EU: Including a provision of 922 kCHF accounted in 2004 with a remaining of 715 kCHF.

DIRAC EU PROJECT - BUDGET OVERVIEW

	EUROS (€)	DURATION
EU Max. contribution for CERN	181,900	01.02.2005 to 31.01.08
CERN received Payment 1	82,659	
CERN received Payment 2	0	
CERN received Payment 3	0	
Total received	82,659	
CERN, to be received	99,241	

EU BUDGET (IN KCHF)	Total budget allocation	Budget used up to 31 Oct. 2006	% used
Total	278	129	46%

CERN BUDGET (IN KCHF)	Total budget allocation	Budget used up to 31 Oct. 2006 ⁽¹⁾	% used
Total	2,042	568	28%

TOTAL EU+CERN Budget	2,320	697	30%
-----------------------------	--------------	------------	------------

EURISOL EU PROJECT - BUDGET OVERVIEW

	EUROS (€)	DURATION
EU Max. contribution for CERN	1,827,000	01.02.2005 to 31.01.09
CERN received Payment 1	548,100	
CERN received Payment 2	0	
CERN received Payment 3	0	
Total received	548,100	
CERN, to be received	1,278,900	

EU BUDGET (IN KCHF)	Total budget allocation	Budget used up to 31 Oct. 2006	% used
Total	2,814	974	35%

CERN BUDGET (IN KCHF)	Total budget allocation	Budget used up to 31 Oct. 2006 ⁽²⁾	% used
Total	4,159	1,504	36%

TOTAL EU+CERN Budget	6,973	2,478	36%
-----------------------------	--------------	--------------	------------

(1) Including expenditure (G.Guignard and U.Raich estimates) not charged to the project's specific budget codes (personnel and material costs for CERN part)

(2) (1) Including expenditure (G.Guignard and M.Lindroos estimates) not charged to the project's specific budget codes (personnel and material costs for CERN part)

EURONS EU PROJECT - BUDGET OVERVIEW

	EUROS (€)	DURATION
EU Max. contribution for CERN	1,346,480	01.01.2005 to 31.12.08
CERN received Payment 1	335,707	
CERN received Payment 2	49,684	
CERN received Payment 3	0	
Total received	385,391	
CERN, to be received	961,089	

EU BUDGET (IN KCHF)	Total budget allocation	Budget used up to 31 Oct. 2006	% used
Total	2,074	844	41%

CERN BUDGET (IN KCHF)	Total budget allocation	Budget used up to 31 Oct. 2006 ⁽¹⁾	% used
Total	2,185	624	29%

TOTAL EU+CERN Budget	4,259	1,468	34%
-----------------------------	--------------	--------------	------------

EUROT_eV EU PROJECT - BUDGET OVERVIEW

	EUROS(€)	DURATION
EU Maximum contribution for CERN	1,482,000	01.01.2005 to 31.12.07
CERN received Payment 1	604,000	
CERN received Payment 2	0	
CERN received Payment 3	0	
Total received	604,000	
CERN, to be received	878,000	

EU BUDGET (IN KCHF)	Total budget allocation	Budget used up to 31 Oct. 2006	% used
Total	2,267	881	39%

CERN BUDGET (IN KCHF)	Total budget allocation	Budget used up to 31 Oct. 2006	% used
Total	2,759	1,593	58%

TOTAL EU+CERN Budget	5,026	2,474	49%
-----------------------------	--------------	--------------	------------

(1) Including expenditure (G.Guignard and K. Riisager estimates) not charged to the project's specific budget codes (personnel and material costs for CERN part)