

EUROTeV-Report-2006-072  
JAI 2006-008

# THE ELECTROMAGNETIC BACKGROUND ENVIRONMENT FOR THE INTERACTION-POINT BEAM FEEDBACK SYSTEM AT THE INTERNATIONAL LINEAR COLLIDER

G. Christian, P. Burrows, C. Clarke, T. Hartin, C. Swinson, G. White, University of Oxford, UK

A. Kalinin, Daresbury Laboratory, UK

R. Arnold, C. Hast, S. Smith, M. Woods, SLAC, USA

## Abstract

The Interaction Point (IP) feedback system is essential for maintaining the luminosity at the International Linear Collider (ILC). It is necessary to demonstrate the performance of the feedback beam position monitor (BPM) in an electron-positron pair background similar to that expected in the ILC interaction region (IR). We have simulated the ILC beam-beam interactions and used a GEANT model of the IR to evaluate the pair and photon flux incident on the BPM, for both the 2 mrad and 20 mrad crossing angle geometries. We present results as a function of the proposed machine parameter schemes, as well as for various system layouts within the IR. We plan to study the degradation of BPM resolution, and the long term survivability, in beam tests at End Station A at SLAC. To simulate the background environment of the ILC a 'spray beam' will be produced, which will scatter from a mechanical mock-up of the forward region of the IR, and irradiate the BPM with realistic flux of secondary pairs. We present the proposed experimental layout and planned beam tests.

## INTRODUCTION

The Interaction-point (IP) feedback system is recognised to be the last line of defence against relative beam misalignment at the International Linear Collider (ILC). To achieve the luminosity required for precision physics the beams need to be focussed down to a few nanometres vertical spot size at the IP, making the beam position very susceptible to ground motion and facilities noise. To correct for these effects the IP feedback concept has been developed, operating on bunch-to-bunch timescales, and prototype systems have been demonstrated at the NLCTA and ATF [1], [2], [3]. The concept uses a stripline beam position monitor (BPM) downstream of the IP to infer the beam-beam offset at the IP and a kicker upstream of the IP on the incoming beamline to provide a corrective kick. Ideally the BPM and kicker would be located as close as possible to the IP to allow a one-to-one correction and to minimise the round-trip latency of the feedback system.

The beam-beam interaction, however, causes large backgrounds of  $e^+e^-$  pairs and photons at the Interaction Region (IR). The predicted backgrounds have been studied using a GEANT model of the IR for both a 2 mrad and 20 mrad crossing angle geometries, as a function of the proposed machine schemes. The detector magnetic field will cause these pairs to spiral around the incoming beam direction, and some of these will hit the downstream masks and forward calorimeters, or the first magnet in the extraction line (Fig. 1), to produce secondary pairs and photons which can go on to hit the feedback BPM. For example, in the case of the 20 mrad crossing angle, the ILC 500 GeV 'scheme 1' parameter set gives  $\sim 200000$  primary pairs per bunch crossing, which produce  $\sim 5000$  secondary pairs that directly hit the BPM strips. In the case of the ILC 1 TeV 'scheme 14', the highest luminosity parameter set,  $\sim 700000$  primaries are produced, resulting in  $\sim 80000$  hits per bunch crossing from secondary pairs.

It has been estimated that for every charge absorbed or ejected from the BPM striplines, a 1 pm degradation in resolution may be observed. BPM hits at the level of  $10^6$  per stripline per bunch crossing will hence degrade the resolution at the micron level or above, which would be noticeable, and degradation at the 10 micron level would seriously impact the performance of the feedback system. Despite the predicted backgrounds being 1 – 2 orders of magnitude below this level, it is possible that the actual backgrounds produced at the ILC may be much larger than predicted and may cause problems for the feedback system. It is necessary therefore to verify the performance of the BPM processor in a realistic environment to that expected in the ILC IR, to study the noise on the BPM signals and ascertain the long-term survivability and performance of the system.

## EXPERIMENTAL PLANS

It is intended to study the effects of background pairs on BPM processor performance in a realistic background created in End Station A (ESA) at SLAC, starting in July 2006. To recreate the backgrounds the main beam will be

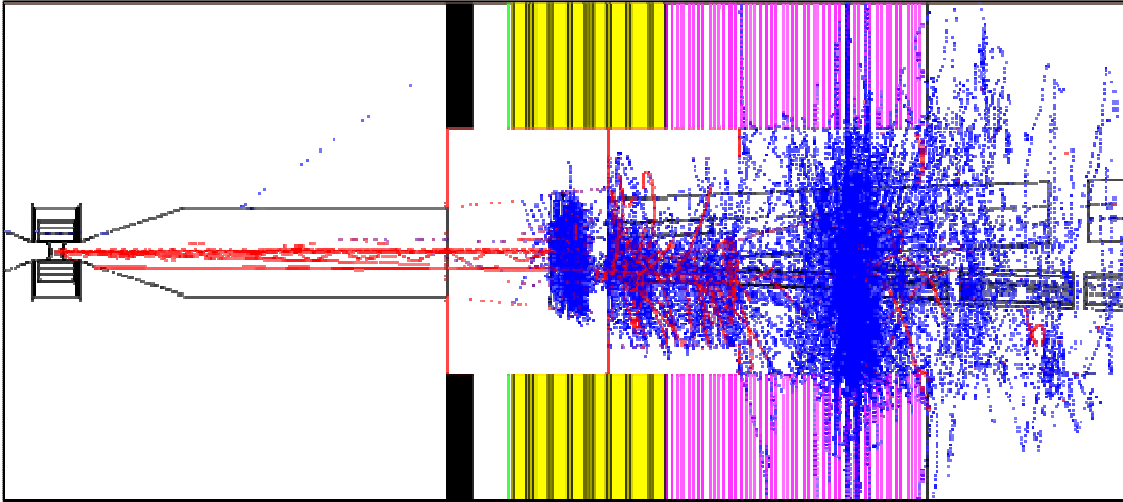
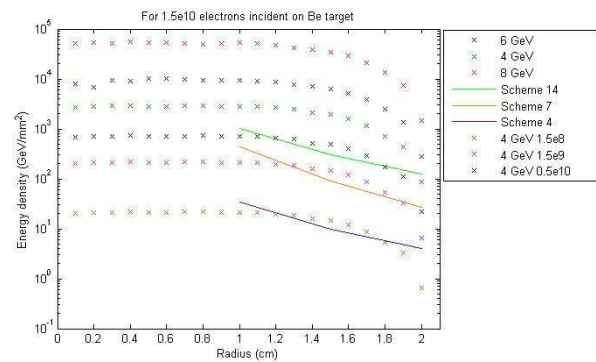

**Figure 1: Example simulation of e+e- pairs produced via the beam-beam interaction and tracked through the material model of the IR. Secondary pairs (red lines) and photons (blue lines) are produced in EM showers originating at the mask and at the front face of QFEX1.**

fired into a target placed after the linac to produce a ‘spray beam’ with the appropriate energy spread and spatial extent [4]. It is planned to utilise an existing 40%  $X_0$  beryllium target located in the beam switch-yard. The energy and intensity of the SLAC main beam and the A-line momentum setting can be selected so as to produce a spray beam with variable energy and flux to model the primary  $e^+e^-$  pair flux in the ILC IR.

Simulations have been made using a GEANT model of the Be target, and tracking the spray beam through the A-line to ESA with MatMerlin. Fig. 2 shows the simulated energy density as a function of radius for a 10 GeV incident beam energy, with A-line momentum settings of 4, 6, and 8 GeV, and for intensities of  $1.5 \times 10^8$ ,  $1.5 \times 10^9$ , and  $0.5 \times 10^{10}$  electrons. Also overlaid are the ILC pair energy density at radius greater than 1 cm, for scheme 4 (ILC 500 GeV), 7 and 14 (ILC 1 TeV). It can be seen that the results for  $1.5 \times 10^8$ ,  $1.5 \times 10^9$ , and  $0.5 \times 10^{10}$  compare well to the scheme 4, 7, and 14 curves respectively, and that, if needed, the spray beam energy density can be increased by up to two orders of magnitude by selecting an intensity of  $1.5 \times 10^{10}$  and increasing the A-line setting from 4 to 8 GeV.

A mechanical mock-up of the material in the outgoing beamline of the ILC will be used to reproduce the flux of secondary pairs which hit the BPM in the ILC IR models. This mock-up will replace a 50 inch section of beampipe in ESA and will provide a realistic geometry and material with which the spray beam will shower. The 50 inch module has been manufactured at Daresbury Laboratory in the UK, and comprises a low-Z absorber, instrumented mask, feedback BPM, and mock-up of the first extraction line quadrupole QFEX1 (Fig. 3 ).



**Figure 2: Spray beam energy density vs. radius from beamline centre in ESA (points), compared with corresponding ILC pair energy density (lines) for parameter schemes 4,7,14 that span the range of expected energy densities.**

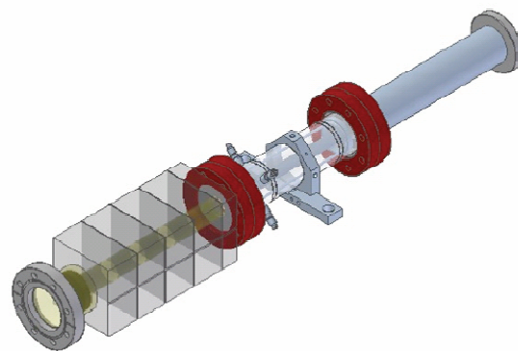

**Figure 3: Test module for insertion in ESA beamline showing: low-Z absorber, Beamcal, FB BPM, material model of QFEX1. The total length is 50 inches.**

## FONT Spray Beam Test Layout in SLAC ESA

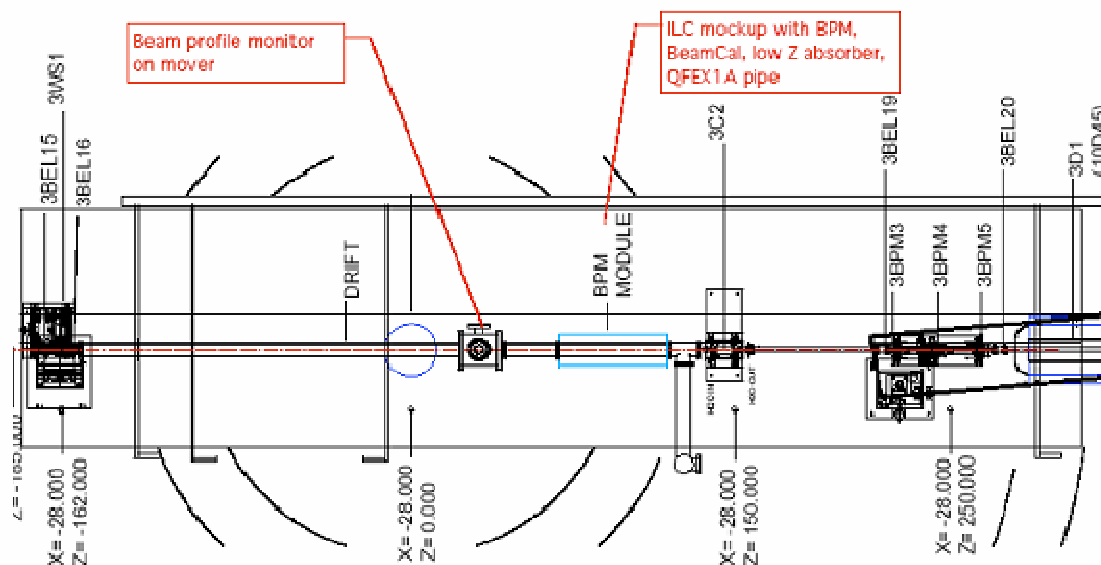

Figure 4: Proposed location for the FONT test module.

To monitor the flux of the spray beam it is proposed to use a low-current toroid and the 3PR3 profile monitor (Fig. 4), with both an aluminium oxide screen and scintillator/mirror 'screen'.

Three different run modes will be used to study the effect of the pair background on the BPM signals. Firstly, without the Be target in place and only the BPM in the beamline, downstream of collimator 3C2, the BPM signals from the primary beam can be recorded under background free conditions. Secondly, with the Be target in place and the BPM upstream of 3C2, the BPM noise signals from the spray beam can be recorded in the absence of the BPM test module. Thirdly, with the Be target in place and the test module located in its nominal position, upstream of 3C2, the BPM noise signals due to the secondary hits on the BPM can be recorded.

## CONCLUSIONS

Simulations of the ILC interaction region have shown that the large  $e^+e^-$  pair and photon backgrounds produced may cause problems for the IP feedback system. The performance and stability of the feedback system in a realistic background environment will be studied in beam tests at End Station A at SLAC beginning in July 2006. A mechanical mock-up of the material in the forward region of the IR has been manufactured to reproduce the flux of secondary pairs which are simulated to hit the BPM strips in the IR model.

This work is supported by the Commission of the European Communities under the 6th Framework Programme "Structuring the European Research Area", contract number RIDS-011899.

## REFERENCES

- [1] P. Burrows, *Feedback on Nanosecond Timescales (FONT): Results from the First Beam Tests at the NLCTA at SLAC*, Proceedings of PAC, Portland, Oregon, May 2003, p.687
- [2] P. Burrows *et al*, *Nanosecond-timescale Intra-bunch-train Feedback for the Linear Collider: Results of FONT2 Run*, Proceedings of EPAC, Lucerne, July 2004, p.785
- [3] P. Burrows *et al*, *Tests of the FONT3 Linear Collider Intra-train Beam Feedback System at the ATF*, Proceedings of PAC, Knoxville, Tennessee, May 2005, p.1359
- [4] R. Arnold and T. Fieguth, *Spray Electron Beam for Tests of the Linear Collider Forward Detectors in SLAC End Station A*, June 2004, IPBI-TN-2004-5