



Numerical studies of a confocal resonator pick-up with FEMLAB

T. Ekelöf, A. Ferrari, M. Johnson, A. Rydberg, V. Ziemann, E. Öjefors*

September 28, 2005

Abstract

Diagnostic devices aimed at measuring beam profiles in high intensity accelerators are often perturbed by microwave fields generated by the beam itself upstream of the detection device, which propagate inside the vacuum pipe. These parasitic waveguide modes can significantly reduce the signal-to-noise ratio and thus the sensitivity of the beam monitor. This warrants investigation of detection devices that are sensitive to the direct electromagnetic fields of the beam, but largely ignore the parasitic waveguide modes. A new pick-up based on a confocal resonator configuration situated transversely to the direction of propagation of the beam is currently under development at Uppsala University, Sweden. Since a confocal resonator can have a high quality factor for the diffraction losses, then reciprocity suggests that it only couples weakly to external fields while keeping anyway a significant coupling to the direct fields of the beam. Numerical simulations were performed with FEMLAB to better characterize the electromagnetic properties of a confocal resonator pick-up to be operated in the multi-GHz range, especially in terms of eigen-frequencies and coupling to external electromagnetic fields. Our results were then compared to analytical predictions and a good agreement was found, despite a few limitations in the computation of the resonant modes. Having recently built a first confocal resonator prototype, we also performed experimental cross-checks of our numerical studies with a microwave network analyzer. Our results are presented in detail in this report and we discuss further applications of the confocal resonator microwave pick-up.

Proceedings of the FEMLAB Conference, Stockholm, October 4-5, 2005

*All authors at Uppsala University, Sweden

1 Introduction

A bunched beam passing through a vacuum pipe with discontinuities often generates microwave fields, which then follow the beam and may therefore be detected by diagnostics devices located downstream, reducing their signal-to-noise ratio and thereby their sensitivity. The electromagnetic field carried by the bunches is a quasi-TEM mode, while the parasitic waveguide modes that travel in the wake of the bunches are TE or TM fields. In a previous report [1] we discussed the conceptual design of a monitor based on a confocal resonator configuration situated transversely to the direction of propagation of the beam and that picks up electromagnetic fields in the multi-GHz region. Such a resonator configuration can have a high quality factor for the diffraction losses. As a result, reciprocity suggests that, while it only couples weakly to external TE or TM fields, this monitor should anyway keep a significant coupling to the direct fields of the beam. In this paper, we focus on a confocal resonator pick-up designed for microwaves with a frequency of 15 GHz. After having reviewed the equations describing the electromagnetic fields and the various losses of such a device, we present the results of numerical simulations aimed at computing the eigen-modes and the coupling to external fields of the confocal resonator. A prototype was recently built at Uppsala University and we also give an overview of our first experimental results.

2 Analytical results

The confocal resonator pick-up that we aim at designing here shall be installed in the CLIC Test Facility CTF3 [2] at CERN in Geneva, Switzerland. Its major purpose shall be to measure the bunch frequency multiplication [3] in CTF3, i.e. the recombination of five 3 GHz bunch trains into a single 15 GHz pulse. For this purpose, we need to design a monitor operating at a wavelength of 2 cm and with dimensions that allow to fit the cavity into the CTF3 vacuum pipe, see Figure 1.

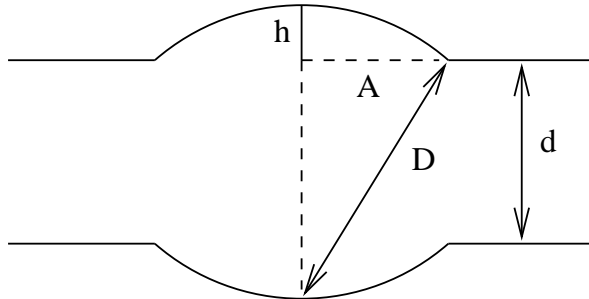

Figure 1: Schematic layout of the confocal resonator inserted into the CTF3 vacuum pipe. In the present design, the height of the CTF3 vacuum chamber is $d = 3.7$ cm. Furthermore, since we consider a confocal resonator, the distance D between the mirrors is equal to their radius of curvature R .

In cylindrical coordinates, the paraxial solution of the wave equation between the round mirrors is described by gaussian beams modulated with associated Laguerre polynomials L_n^m [4]. With vanishing fields at the surface of the mirrors, the resonance condition is:

$$\frac{4fD}{c} = 3 + m + 2n + 4l,$$

where l is an integer number. For the resonant mode at 15 GHz, we have considered $m = n = 0$ and $l = 3$, which imposes the distance between the mirrors to be $D = 7.5$ cm. The elevation of the zenith of the mirror domes above their edges is $h = 1.9$ cm, and the mirror radius is $A = 4.99$ cm. With this geometry, the resonance condition can be re-written as follows:

$$f = 4 \text{ GHz} \times \frac{3 + m + 2n + 4l}{4}.$$

In Figure 2, we show the intensity distribution (i.e. the squared electric field) of the $(0, 0)$ mode at 15 GHz ($l = 3$) between the two mirrors, along the z -direction (left) and in the $z = 0$ plane (right).

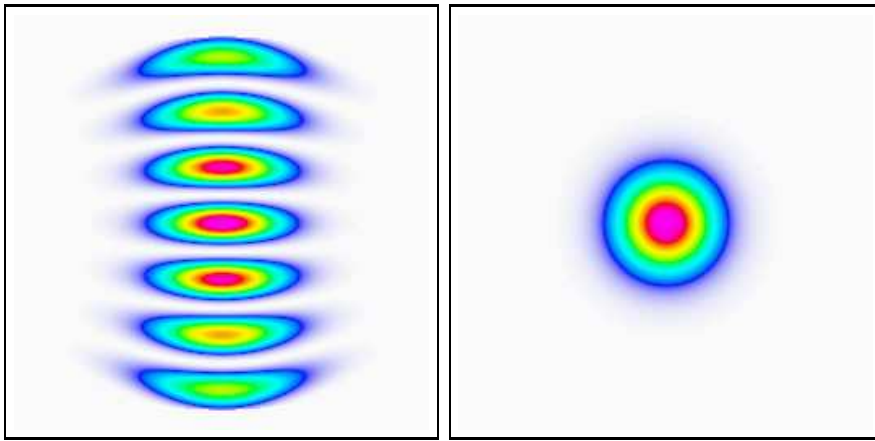

Figure 2: Intensity distribution between the mirrors along the z -direction (left) and in the $z = 0$ plane (right) for the $(0, 0)$ mode with $l = 3$, i.e. at 15 GHz.

Note that, in our configuration, a resonant frequency of 15 GHz can be obtained not only by considering the $(0, 0)$ mode with $l = 3$, but with other combinations of m , n and l as well, such that $m+2n = 4$ with $l = 2$, or $m+2n = 8$ with $l = 1$, or $m+2n = 12$ with $l = 0$.

Having established the shape of the modes, let us now discuss the losses that determine the Q -value and thereby the sensitivity of the confocal resonator.

We start by discussing the losses due to the surface resistivity R_s of the mirror. The corresponding quality factor Q_r only depends on R_s and a geometry factor G common to all modes [4]:

$$Q_r = \frac{G}{R_s}, \text{ where } G = 377 \Omega \times \frac{\pi}{2} \times \frac{D}{\lambda}.$$

Let us now discuss the diffraction losses due to the finite extension of the mirrors and to the non-zero field amplitude at their edges. The relevant parameter is the Fresnel number $N_F = A^2/D\lambda$. The fractional power loss per bounce at each mirror due to the diffraction losses can be written as follows [4]:

$$\alpha_d = \frac{2\pi (8\pi N_F)^{m+2n+1} e^{-4\pi N_F}}{(m+n)!n!}.$$

The smallest diffraction losses occur for eigen-modes with $m = n = 0$ and these losses decrease exponentially with N_F , i.e. as the mirror radius increases. The quality factor Q_d corresponding to the diffraction losses is:

$$Q_d = \frac{2\pi D}{\alpha_d \lambda}.$$

For a frequency of 15 GHz, there are 16 different modes in the confocal resonator. All of them have the same Q_r -value (it is 5.5×10^4 if the mirrors are made of Aluminium), but their Q_d -values differ by several orders of magnitude, as shown in Table 1.

Table 1: List of all (m, n) modes present in the confocal resonator at 15 GHz, with their corresponding Q_d -value.

Integer number l	m	n	Q_d at 15 GHz
$l = 3$	0	0	1.0×10^8
$l = 2$	4	0	8.2×10^2
	2	1	2.0×10^2
	0	2	1.4×10^2
$l = 1$	8	0	4.5×10^{-1}
	6	1	5.6×10^{-2}
	4	2	1.6×10^{-2}
	2	3	8.1×10^{-3}
	0	4	6.5×10^{-3}
$l = 0$	12	0	1.8×10^{-3}
	10	1	1.5×10^{-4}
	8	2	2.7×10^{-5}
	6	3	8.1×10^{-6}
	4	4	3.6×10^{-6}
	2	5	2.2×10^{-6}
	0	6	1.9×10^{-6}

Having analytically determined the eigen-modes of the confocal resonator, as well as their quality factors, numerical simulations were then performed in order to check our theoretical predictions.

3 FEMLAB simulations

The FEMLAB program [5] was first used to compute numerically the eigen-modes of our confocal resonator. However, the FEMLAB eigen-frequency solver does not allow to define purely open radiative boundaries around the confocal resonator. We consider a closed structure when computing the eigen-modes instead, where the confocal resonator is surrounded by an object with perfectly conducting boundaries. One major drawback is that not only the confocal resonator eigen-modes are computed, but also the resonant modes of the surrounding object. We have chosen two surrounding structures in this study: a cylindrical box with a radius of 10.0 cm and a height of 3.7 cm, or a square box with dimensions 13.5 cm \times 13.5 cm \times 3.7 cm. The resonant modes of these two structures were computed with FEMLAB. Those coming from the surrounding object are different if one chooses a cylindrical or a square box, while the eigen-modes of the confocal resonator are common to both configurations, especially when the associated Q_d -value is large. At low frequency, the surrounding box contributes with a small number of modes, so the search for the confocal resonator eigen-frequencies is straightforward. Figure 3 shows the confocal resonator mode found by FEMLAB at 2.90 GHz, for both geometrical configurations. The shape of the mode corresponds to $m = n = 0$ with $l = 0$, i.e. it has a Gaussian field distribution along r with no dependence on ϕ and one maximum along the z -axis. However, its frequency is somewhat smaller than 3 GHz. Due to the diffraction losses, part of the electromagnetic field escapes the confocal resonator and thus feels the presence of the surrounding box. The resonance condition is not only imposed by the vanishing field at the mirror surface, but also by a zero field at the edges of the surrounding structure. Intuitively, since its dimension is larger than the distance between the mirrors, the box tends to lower the confocal resonator eigen-frequency.

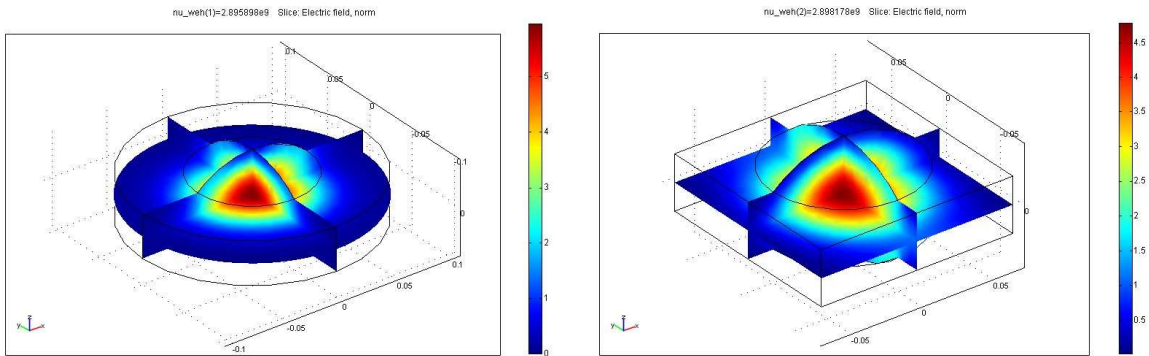

Figure 3: Eigen-mode found by the FEMLAB eigen-frequency solver in the confocal resonator surrounded by a cylindrical box (left) or a square box (right), for a frequency close to 3 GHz.

When going to higher frequencies, the search for the confocal resonator eigen-modes is less straightforward, because the surrounding box contributes with a lot of parasitic resonant modes. Also, in order to have a good accuracy for the computation of the eigen-modes, one should have about five mesh points by wavelength. At high frequency, the number of mesh elements becomes very large and the computation crashes if there is not enough available memory. One solution to both these problems is to use symmetry planes: these remove some unwanted modes coming from the surrounding box and they allow significant reduction of the amount of mesh points. This method allowed us to easily find the fundamental mode of the confocal resonator at 15 GHz, i.e. with $m = n = 0$ and $l = 3$, see Figure 4. A few other eigen-modes could also be identified at 15 GHz but the presence of many parasitic modes from the surrounding box and the mesh restrictions remain major limitations when searching for all confocal resonator modes.

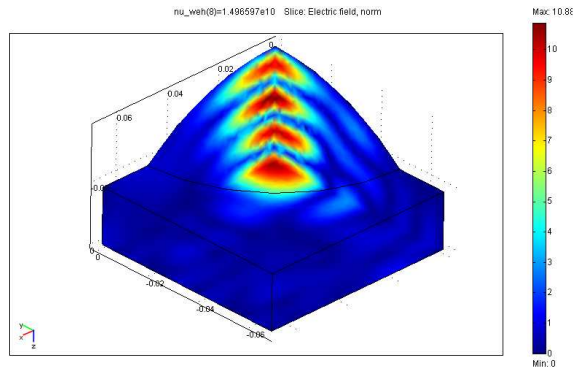

Figure 4: Eigen-mode found by FEMLAB in the confocal resonator surrounded by a square box at 15 GHz (three symmetry planes were used for this computation).

The FEMLAB simulation package was also used in order to study the coupling of the confocal resonator to external electromagnetic fields. For this purpose, we considered a structure similar to the one shown in the lower plot of Figure 3, i.e. a square box with dimensions $13.5 \text{ cm} \times 13.5 \text{ cm} \times 3.7 \text{ cm}$ surrounding the confocal resonator. However, we do not consider perfectly conducting boundaries anymore but we use low-reflecting boundaries instead, which allows to simulate an open structure. In addition, a waveguide is connected to the upper mirror of the confocal resonator to extract (or to inject) microwave signals. In order to study the confocal resonator behaviour, we use this waveguide as an input port, while the open boundaries of the square box are the output ports. The waveguide dimensions can be chosen such as one single mode propagates there, whereas a large number of TE or TM modes should be considered at the output ports. Therefore, in the following, we use the S11 parameter in order to derive the main properties of the confocal resonator.

Simulations were first performed at frequencies for which the number of eigen-modes inside the confocal resonator remains small. A waveguide with dimensions $4.2 \text{ cm} \times 1.0 \text{ cm}$ was connected to the upper mirror of the confocal resonator and microwave signals between 4.5 and 7.5 GHz were injected into it. The variation of the S11 parameter with frequency is shown in Figure 5. When there is no resonance, the signals injected by the waveguide between the mirrors tend not to oscillate in the confocal resonator and thus escape through the open boundaries of the surrounding box: S11 remains thus rather small. When the resonance condition is satisfied, the diffraction losses become very small and the eigen-modes are trapped inside the confocal resonator. Since a fraction of the power oscillating between the mirrors couples back to the waveguide, S11 becomes larger. This is clearly the case around 5 and 7 GHz. In theory, it should occur at 6 GHz as well, but the corresponding mode with $m = n = 1$ has a zero-field at the centre of the confocal resonator and thus does not couple to the waveguide. Note that there is only one peak in the S11 spectrum at 5 GHz, while a more complex structure is observed for the resonance at 7 GHz. This is related to the number of confocal resonator eigen-modes as well as their Q -values. At 5 GHz, the resonance condition can only be satisfied when $m + 2n = 2$ and $l = 0$, i.e. by two modes for which Q_d differs by a factor 2 only. On the other hand, two values of $m + 2n$ satisfy the resonance condition at 7 GHz: 0 and 4. There are thus four eigen-modes (one with $l = 1$ and three with $l = 0$), which have very different quality factors: Q_d is indeed five orders of magnitude larger for the three modes with $l = 1$ than for the mode with $l = 0$. In the presence of imperfections (for instance the hole in the upper mirror that couples the confocal resonator and the waveguide), some energy transfer between orthogonal eigen-modes that have very different quality factors may occur, which gives rise to several resonance peaks instead of one, at frequencies which slightly differ from 7 GHz.

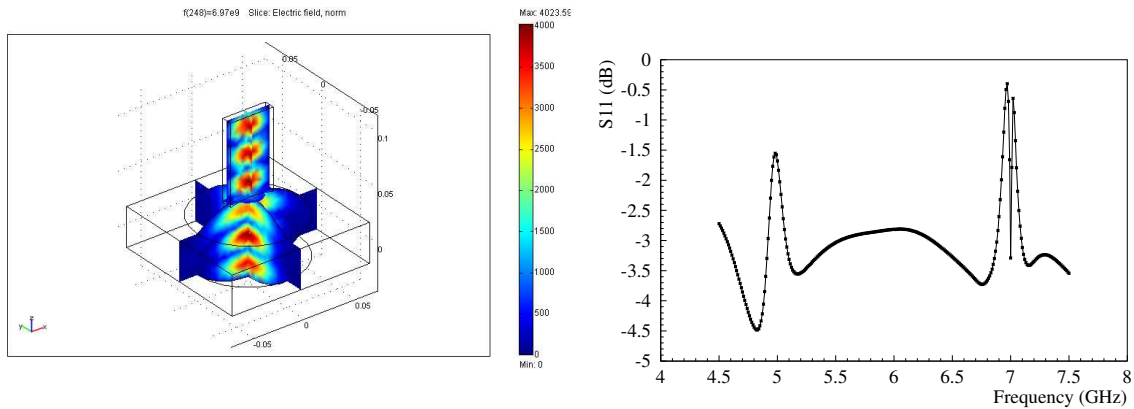

Figure 5: Electric field in the confocal resonator surrounded by an open square box and coupled to a waveguide (port 1), obtained by FEMLAB at 6.97 GHz (left), and S11 parameter as a function of frequency between 4.5 and 7.5 GHz (right).

Similar simulations were performed around 15 GHz. The dimensions of the confocal resonator are the same but, for the waveguide, one has $1.58 \text{ cm} \times 0.79 \text{ cm}$. Since there are several eigen-modes inside the confocal resonator, one can not reduce the amount of mesh points with symmetry planes, otherwise some modes may not be taken into account, leading to a false estimation of S11. The whole geometry was thus considered, which limits the mesh size and thereby the accuracy of the S11 computation. Figure 6 shows how S11 varies with frequency near 15 GHz, with and without resistive losses in the Aluminium mirrors. In both cases, the distortion of the resonance by the coupling between eigen-modes with very different quality factors is clearly visible. In this configuration, losses are mostly due to the large hole that connects the waveguide and the confocal resonator, therefore an accurate determination of the quality factors is not possible. Instead, one should have a small iris in the upper mirror, through which microwave signals can be transmitted from the waveguide to the confocal resonator, and vice versa. This iris acts as a shunt inductance. Its diameter must be carefully chosen such that the waveguide and the confocal resonator, with its coupling hole, have the same impedance at 15 GHz (note that the latter depends on the total quality factor of the confocal resonator). Typically, the coupling iris has a diameter of a few mm. In order to implement the iris into FEMLAB and study its effect on the S11 parameter, one needs a very fine mesh at the interface between the waveguide and the confocal resonator, which leads to an increased number of mesh points. The amount of memory needed in order to run these simulations around 15 GHz usually exceeds what can be allocated by the computer.

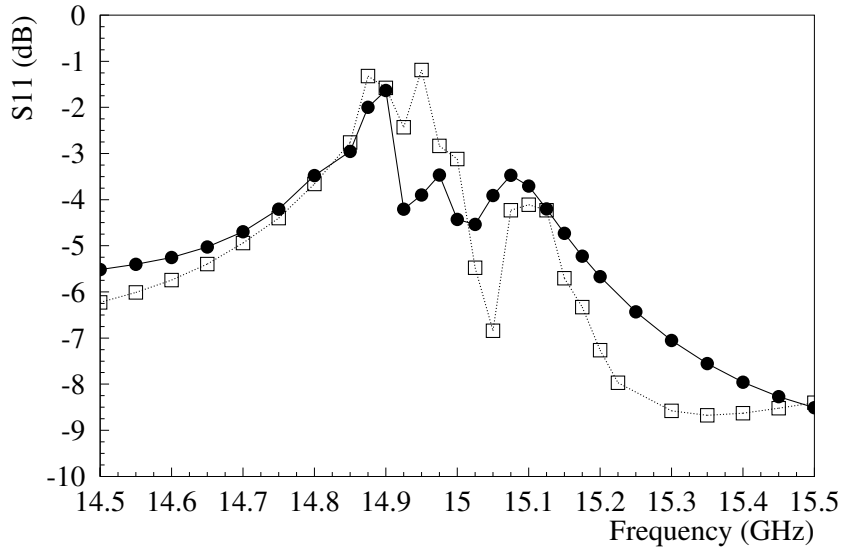

Figure 6: S11 parameter as a function of frequency between 14.5 and 15.5 GHz when the input port is a WR62 waveguide. Full circles and open squares respectively show results obtained with and without resistive losses in Aluminium mirrors.

Two major limitations were identified in FEMLAB, which prevent us from performing accurate simulations of the confocal resonator. First, one can not use open boundary conditions when computing eigen-frequencies. Due to the necessary presence of a surrounding closed box, the confocal resonator becomes overmoded and the identification of its eigen-modes is not straightforward. In addition, at the frequency of interest, i.e. 15 GHz, the constraints on the mesh are such that large structures and/or small details can not be simulated accurately. This warrants construction of a prototype to investigate the electromagnetic properties of the confocal resonator at high frequency.

4 Experimental results

In order to experimentally test the confocal resonator and to check the validity of our simulations, we have built a simple prototype, which consists of two Aluminium plates of $13.5 \text{ cm} \times 13.5 \text{ cm}$ facing each other, that are separated by 3.7 cm, from which a spherical cavity with radius 7.5 cm and depth 1.9 cm was carved out. A WR62 waveguide, with dimensions $1.58 \text{ cm} \times 0.79 \text{ cm}$, was connected to the upper plate, see Figure 7. Microwave signals were generated and injected into this waveguide using a network analyzer (Agilent Technologies E8364B PNA series).

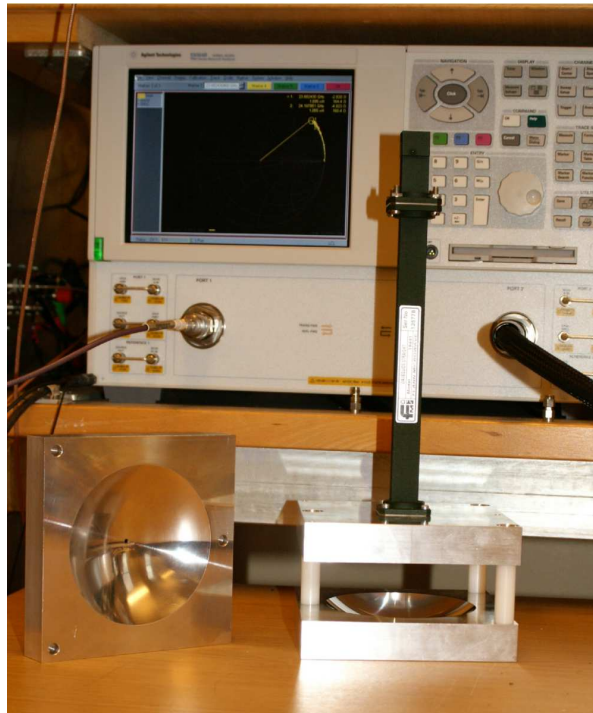

Figure 7: Confocal resonator prototype and its extraction waveguide, with the network analyzer in the background. One Aluminium plate with its mirror cavity is also shown.

Our first series of measurements was performed with the waveguide going directly into the upper mirror of the confocal resonator, i.e. without any small coupling hole. The S_{11} parameter was measured over the whole frequency range of the WR62 waveguide, i.e. from 12.4 to 18.0 GHz, and also more accurately around 15 GHz, see Figure 8. Resonances are only clearly observed for odd values of the frequency, which corresponds to even values of m since $f [GHz] = 3 + m + 2n + 4l$. Indeed, when m is odd, there is a zero-field at the centre of the confocal resonator and thus a much smaller coupling to the waveguide. All resonances show a complex structure with several peaks. This suggests the presence of some coupling between the different confocal resonator eigenmodes. Note the similarity of the results obtained with FEMLAB simulations and with our prototype. Note also that the resonance is very wide, which typically indicates a small loaded quality factor: most of the losses in the confocal resonator occur because of the large coupling hole in the upper mirror.

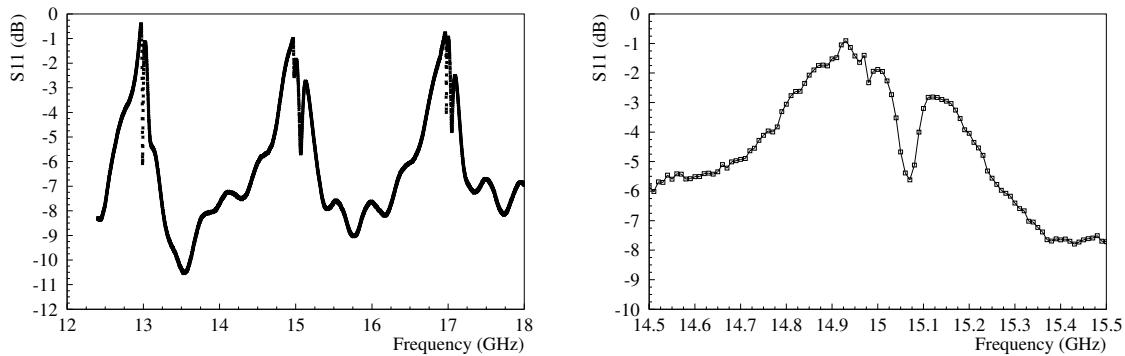

Figure 8: S_{11} parameter versus frequency for the confocal resonator coupled to a WR62 waveguide, measured with a network analyzer between 12.4 and 18.0 GHz (left) and between 14.5 and 15.5 GHz (right). The input port is the waveguide.

Another series of measurements was performed with a prototype in which the waveguide is coupled to the confocal resonator through a small circular hole. For the sake of simplicity, we installed a thin layer of copper-tape at the interface between the confocal resonator and the waveguide, on the upper mirror, and we drilled a hole with a 5 mm diameter through it. The S_{11} parameter was again measured as a function of frequency around 15 GHz and, this time, a clear resonance was observed, see the upper plot of Figure 9. With no resonance in the confocal resonator, the microwave signals injected into the waveguide are fully reflected by the small iris. Transmission indeed occurs when the resonance condition is satisfied, with a good matching between the impedances of the waveguide and of the confocal resonator with its coupling hole. In addition, one can derive the loaded quality factor of the confocal resonator from the bandwidth of the resonance: we found $Q_{loaded} = 1800$. The bottom plot of Figure 9 shows the same resonance in a Smith-chart. The loop corresponds to the resonance peak. If there was a perfect coupling through the iris, this loop would pass through the centre of the Smith-

chart. Here, we have an undercoupled configuration, i.e. either the iris diameter or the Q -value of the confocal resonator is too small. The presence of the copper-tape around the coupling iris and the possible oxydation of the Aluminium mirrors certainly lower the quality factor of the confocal resonator. We also suspect that the resonance condition may not be satisfied for the (0,0) mode: if significant diffraction losses indeed occur, this leads to a much lower total quality factor than expected.

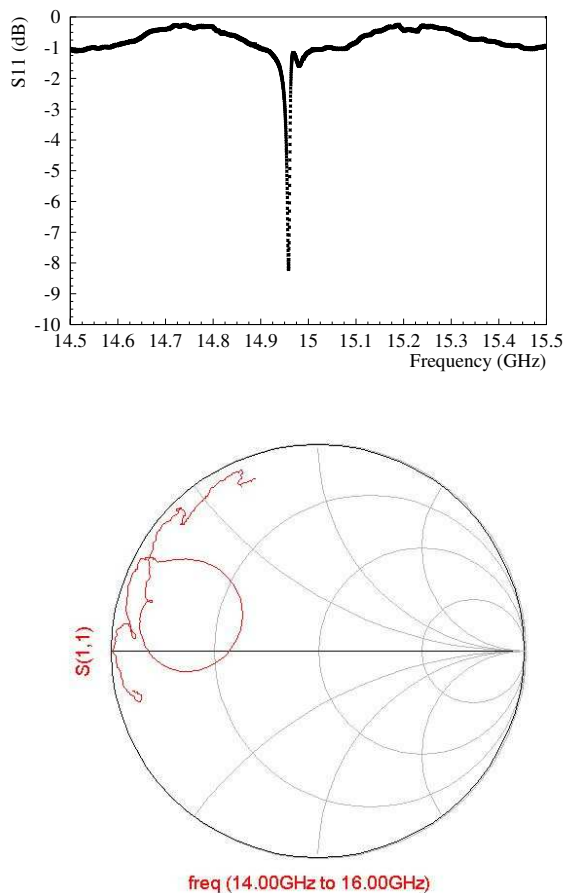

Figure 9: S11 parameter as a function of frequency for the confocal resonator coupled to a WR62 waveguide through copper-tape with a 5 mm iris, measured with a network analyzer between 14 and 16 GHz. A direct measurement of the resonance (top) and a Smith-chart (bottom) are shown.

We have also replaced the copper-tape iris by a 1 mm deep coupling hole drilled directly in the upper mirror, with various diameters between 3 and 5 mm. In all cases, the confocal resonator and the waveguide remain undercoupled. More investigations are required to reach the resonance condition. In particular, the confocal resonator configu-

ration seems to be extremely sensitive to misalignment errors and our experimental set-up needs to be improved in order to better control such errors, up to the micrometer level.

5 Conclusion and outlooks

In this paper, we have reported on various FEMLAB simulations of a confocal resonator pick-up and on the experimental tests that we performed with this device around 15 GHz. The confocal resonator shall later be used as a new beam instrument that allows rejection of parasitic waveguide modes propagating in a vacuum pipe, while keeping a significant coupling to the quasi-TEM field of the beam. Several FEMLAB simulations were performed in order to compute the eigen-frequencies of a confocal resonator surrounded by a box with perfectly conducting boundaries. For the eigen-modes with small diffraction losses, the electromagnetic field pattern and the eigen-frequency agree very well with the analytical predictions. With larger diffraction losses, the electromagnetic field becomes more sensitive to the boundary conditions of the surrounding box, hence the confocal resonator eigen-modes are more difficult to find. Another limitation for our study is that, when going to higher and higher frequencies, the amount of modes coming from the surrounding box increases and the identification of the confocal resonator eigen-modes is less and less straightforward. Also, since one needs to keep a fair amount of mesh points per wavelength, FEMLAB can not handle the computation of electromagnetic fields in large over-moded structures. It is also difficult to implement small sub-structures, such as a coupling hole with only a few mm in radius or depth between the confocal resonator and a signal extraction waveguide.

A first prototype, aimed at studying experimentally the electromagnetic properties of the confocal resonator, was built. A WR62 waveguide was used to inject (or to extract) microwave signals into (or from) the confocal resonator, and S11 parameters were measured as a function of frequency to identify resonances and determine their Q -values. The presence of a small iris at the interface between the waveguide and the confocal resonator leads to a significant difference for the resonance shape and allows more accurate determination of the losses, on condition that one properly designs this coupling hole. This is one of the next challenges to be met in our study. In addition, we plan to improve our experimental set-up by mounting the confocal resonator on a test-bench with an alignment accuracy of a few micrometers only, in order to test the influence of all degrees of freedom on the performance of the confocal resonator. We then plan to build another type of experimental set-up, which consists of a confocal resonator installed on a piece of beam pipe. This allows to measure directly transmission factors (S12 parameters) and thus the confocal resonator performance in terms of parasitic waveguide mode rejection. Finally, the commissioning of a confocal resonator pick-up with a CTF3 beam is planned in 2007.

Acknowledgements

This work is supported in part by the Commission of the European Communities under the 6th Framework Programme "Structuring the European Research Area", contract number RIDS-011899.

References

- [1] F. Caspers, A. Ferrari, T. Lofnes, I. Syratchev and V. Ziemann, "Conceptual design of a microwave confocal resonator pick-up", CERN-AB-2004-053, Proceedings of EPAC 2004, Lucerne, Switzerland.
- [2] G. Geschonke and A. Ghigo (editors), "CTF3 Design Report", CERN/PS 2002-008 (RF), LNF-02/008 (IR).
- [3] F. Tecker *et al.*, "Bunch frequency multiplication in the CLIC Test Facility CTF3", CLIC note 565, CERN-AB-2003-042-OP, Proceedings of PAC 2003, Portland, USA.
- [4] N. Klein, "Proposal for a superconducting open resonator and its application as a gravitation balance detector", External Report, Bergische Universität, Wuppertal, February 87.
- [5] <http://www.comsol.com/products/femlab/>