

PROGRESS AND PLANS FOR R&D AND THE CONCEPTUAL DESIGN OF THE ILC INJECTOR SYSTEMS

S. Guiducci, INFN-LNF, Frascati, Italy

Abstract

The International Linear Collider (ILC) Injector is a complex of different subsystems that are strictly correlated: positron source, polarized electron source, damping rings and bunch compressor. The choice of parameters of each subsystem has a strong influence on the others. A description of the critical items requiring further R&D in order to finalize the choice of the parameters needed for the Conceptual Design is given. The status and plans of R&D in progress on these items at a global level are reported.

INTRODUCTION

After the choice of the Super Conducting RF “cold” technology by the International Recommendation Panel in August 2004, the 1st International Linear Collider Workshop [1] was held at KEK to start the collaboration toward an international design between Asia, Europe and US. Workshops and meetings are used to provide communication between different groups working on the injector subsystems.

A 2nd Workshop will be held at Snowmass in August to start the definition of the baseline ILC configuration for the Conceptual Design Report.

The injection system is one of the crucial issues of this decision process. The success of ILC will depend also on the capability of the injector to produce high intensity, low emittance beams with good efficiency and low losses.

The ILC Injector Systems

The ILC Injector is a complex of strictly correlated subsystems, which must provide electrons and positrons

inject them into Damping Rings (DR) to reduce the transverse emittances, and transfer them into the Main Linacs travelling through bunch length compressors. Polarization of both beams is highly desirable for the experiments. For polarized beams a spin rotator system is needed before transfer to the Main Linacs.

The choice of the parameters of each Injector Subsystem has an influence on the others and the quality and stability of the extracted beam has an impact on the luminosity. The optimization of the IS parameters is therefore a crucial task.

A schematic design of the ILC showing the injector subsystems is presented in Fig.1. The nominal design parameters for the ILC injector system [2] are given in Table I.

Table I: ILC main parameters

Rep. rate (Hz)	5	Particles/bunch	$2 \cdot 10^{10}$
Train length (ms)	~ 1	Norm.horizontal emit. $\gamma\epsilon_x$ (m)	$8 \cdot 10^{-6}$
N. bunches/train	2820	Norm.vertical emit. $\gamma\epsilon_y$ (m)	$2 \cdot 10^{-8}$
Bunch dist. (ns)	337	Bunch length (μm)	300
Luminosity @500 GeV c.m. ($\text{cm}^{-2} \text{s}^{-1}$)		$2.0 \cdot 10^{34}$	

POLARIZED ELECTRON SOURCE

The design of an electron source for ILC will be based on well tested systems; only the polarized source poses new R&D challenges. A polarized electron source successfully operated already at the SLC [3]: 80% polarization was achieved with a strained lattice GaAs cathode with a quantum efficiency of 0.1%.

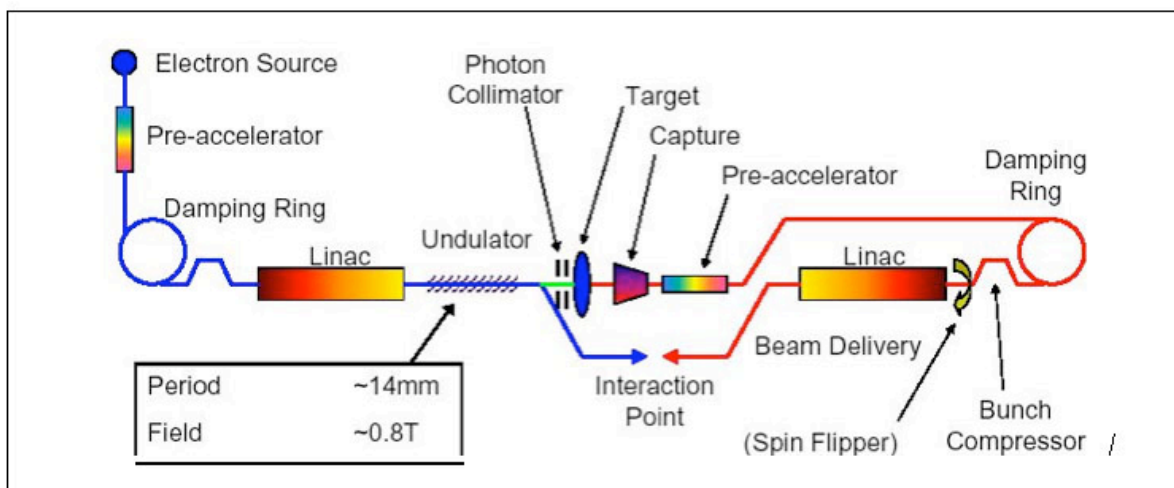

Figure 1: Schematic layout of ILC

* Work supported in part by the Commission of the European Communities under the 6th Framework Programme “Structuring the European Research Area”, contract number RIDS-011899.

A design capable of delivering a much higher charge per bunch was made for NLC [4]. The characteristics of a source for a SC linac, similar to that required for ILC, are also described in the TESLA TDR [5]: the charge per bunch needed is nearly the same as for NLC but the different time structure of the bunches poses more demanding requirements on the laser system.

The present status of R&D on polarized e- injector for ILC is very briefly summarized below [6].

Polarization larger than 85% is assured using well-tested GaAs/GaAsP strained lattice photocathodes, with R&D continuing towards 100% polarization. Photoemission study for the long ILC linac pulse (~1 ms) is needed. The large charge required for ILC can be produced using SLC type systems; many good technologies have been developed to design a state of the art gun. ILC laser needs substantial R&D.

POSITRON SOURCE

The positron charge needed for ILC is a factor 10^3 larger than that achieved at SLC and therefore this is one of the most demanding items of the injection system. For a “conventional” source like the SLC one it is very challenging to achieve such a large number of positrons, and therefore an “undulator based” novel scheme has been proposed [2]; more recently alternative schemes based on Compton scattering have been also put forward [7]. A conventional source uses electrons hitting on a target, while the other two schemes use photons and therefore, by means of polarized photons, can also produce polarized positrons.

Undulator based source

The high energy, low emittance electron beam passing through a long undulator produces a high flux of photons (10-40 MeV). The electrons are deviated by a small angle bend and sent to the Interaction Point, the photons are collimated and sent on a thin (0.4 radiation length X0) Ti Alloy target to produce positrons. The capture system after the target is similar for all the schemes: an adiabatic matching device (high field pulsed focusing lens) and a high gradient RF capture section surrounded by a focusing solenoid. Positrons need then to be transported back to the beginning of the linac (see Fig. 1).

The main advantages of this source with respect to a conventional one are the lower neutron production rate and lower energy deposition in the target, which reduce the problems of heat removal, radiation damage and shielding in the target area and in the capture system.

Another advantage is the smaller transverse emittance of the positrons which, probably, can be matched to the DR acceptance without the need of a large acceptance pre-Damping Ring.

With this scheme polarization of the positron beam can be achieved by using a helical undulator, which produces circularly polarized photons, instead of a flat one. However, the design of the flat undulator is straightforward while for the helical one R&D is needed. There

are proposals for permanent magnet and SC prototypes [8].

The disadvantages of the undulator scheme are due to the use of high energy colliding electrons to produce positrons. This increases the complexity of the system and has a negative impact on commissioning and availability.

‘Conventional’ source

The conventional source consists of a 6 GeV electron beam [9] hitting a thick target (4.5 X0) made of a WRe alloy. The target is a wheel rotating at 360 m/s and is cooled with water in flow channels. The capture system is similar to that of the undulator source but is more demanding due to the larger energy deposition and the larger emittance of the positrons. Due to the large positron emittance, the increase of the DR acceptance with a pre-DR could be needed to increase the positron yield. The region of the source is a high radiation environment: radiation hard components and remote handling for maintenance and repair are necessary.

All the problems related to power removal, heat damage, radiation damage and radiation shielding are more challenging with respect to the undulator source. On the other hand a conventional source allows separation of positron production from colliding electrons, which improves commissioning and availability and allows more operational flexibility.

Compton source

There is a proposal of producing polarized positrons using circularly polarized photons obtained by Compton backscattering of laser light by an electron beam. Production of polarized positrons with this method has been demonstrated at ATF [7,10]. The photon flux obtained in the laser-electron beam collision is much lower than that required for the ILC positron source: different schemes have been proposed to multiply the number of collision points. These schemes are at an early design stage but could be a promising alternative in the future.

DAMPING RING

DR are used to reduce the large normalized emittance of the source in order to get the very small beam sizes at the IP needed for the design luminosity. DR requirements are: low emittance, short damping time and high current. In the following the main DR issues are summarized.

For positrons, nearly 7 damping times are needed to reach an extracted emittance very close to the equilibrium one; this condition determines the required betatron damping time: $\tau_{x,y} < 28\text{ms}$ at 5 Hz repetition rate.

In order to compress the long linac pulse train (~ 300 Km) down to the DR length the rise and fall time of injection/extraction kickers must be shorter than the DR bunch distance. The 17 Km long DR of the TESLA design [2] is based on a 20 ns bunch distance. Shortening the linac pulse affects directly the luminosity, therefore it is clear that the feasibility of ultra fast kickers is the key issue for the DR design.

Large DR acceptance is needed to get high positron injection efficiency; this in turn asks for large magnetic apertures, i.e. high costs, strong kickers and a large Dynamic Aperture (DA). A long wiggler section is also necessary to get a short damping time but nonlinearities in the wiggler field could reduce the DA. A dedicated study of this issue is in progress. The high current and short bunch distance can cause instabilities and collective effects, which limit the maximum current and deteriorate the emittance. Fast ion instability in the e^- ring and e-cloud effect in the e^+ one are a concern. Studies to estimate and mitigate these effects are in progress [11]. Space charge incoherent tune shift becomes important due to the long circumference and small emittance.

As an example typical DR parameters are compared with those of some operating machines in Table II.

The characteristics of the B and Φ -Factories [12] are: large number of particles per bunch, short bunch distance, short bunch length, the same as for the DR, but their emittances are much larger. The powerful longitudinal and transverse feedback systems used in the Factories to damp instabilities can be implemented in the DR as well. However it should be understood if it is possible to use feedbacks without causing emittance growth. In any case the DR will have lower current and faster radiation damping, which should mitigate instabilities.

The Accelerator Test Facility (ATF) DR at KEK has been designed as a test machine to produce a low vertical emittance beam and to test the advanced diagnostics (laser wire beam profile monitor, high resolution BPMs, etc.) required to measure it.

A 4 pm vertical emittance, the smallest emittance ever achieved, has been measured at low current [13]. Due to the low energy, a beam size growth due to Intra Beam Scattering is observed at higher current. At 1×10^{10} part/bunch there is an increase by a factor 1.5; however the normalized emittance is still smaller than that required for the DR.

ATF is a very short ring with redundant diagnostics (96 BPMs in each plane), and redundant orbit and coupling correction systems (97 orbit correctors, 68 skews). It is important to understand how its achievements can be scaled to a 17 Km DR.

The feasibility of 2 pm vertical emittance has to be demonstrated. It depends on the capability of achieving ultra low values of closed orbit, coupling and vertical dispersion and requires efficient correction algorithms.

DR Layouts

For the DR there are still critical items which require a decision before finalizing the baseline design for the CDR. First of all the layout: there are proposals for 17, 6 and 3 Km long DRs. For TESLA (17 Km) a dogbone design with two long straight sections in the linac tunnel, connected by relatively short arcs (total arc length ~ 2 Km) has been proposed. This solution allows to save on tunnel length but has a negative impact on commissioning and availability and could affect the low emittance due to the stray fields in the linac tunnel. On the other hand, a short ring would be accommodated in a dedicated tunnel with evident advantages in terms of availability.

Many different DR lattices and layouts have been proposed, and a list of their parameters is reported in Table III. The lattices are based on different arc cells (FODO, TME, π) and have different lengths. All the lattices show an horizontal emittance smaller than the nominal one, demonstrating that there is a reasonable safety margin on this parameter.

The radiated energy per turn, needed to achieve the nominal damping time, is proportional to the ring length. Therefore long lattices require a long wiggler section and a large RF voltage. For short lattices it is easier to achieve the nominal damping time or even shorter.

A comparative study of the lattices performances, by applying the same tools and assumptions to all them, will produce the necessary input to the CDR baseline configuration.

The final choice will be based on many issues; in particular the following items certainly need more studies and experimental tests:

- Minimum achievable emittance
- e-cloud and fast ion instability
- Incoherent space charge tune shift
- Other collective effects
- Wiggler optimization and dynamic aperture

Table II: Comparison of DR parameters with operating storage rings

	DAFNE	KEK-B LER/HER	PEP-II LER/HER	ATF	DR
E (GeV)	0.5	3.5/8	3.1/8.99	1.28	5
C (m)	98	3016	2199	138	17000/3000
N (10^{10})	2.0	7.7/5.9	9.3/5.	0 - 1.0	2.0
Bunch distance (ns)	2.7	7.8	6.3	2.8	20./3.
$\gamma\epsilon_x$ ($\mu\text{m-rad}$)	400	120/380	200/860	3/5	8
$\gamma\epsilon_y$ ($\mu\text{m-rad}$)	1.0	5.6/11	12/44	0.01/0.015	0.02
ϵ_x (m-rad)	4.1×10^{-7}	$(1.8 - 2.4) \times 10^{-8}$	$(3.3 - 4.9) \times 10^{-8}$	$(1.2 - 2.0) \times 10^{-9}$	8.2×10^{-10}
ϵ_y (m-rad)	1.0×10^{-9}	$(8.2 - 7.1) \times 10^{-10}$	$(2.0 - 2.5) \times 10^{-9}$	$(4 - 6) \times 10^{-12}$	$2. \times 10^{-12}$
σ_z (mm)	19	8.0/6.0	12	5/9	6.0
τ_x (ms)	36	43/46	62/37	18	<28
I average (A)	1.0	1.6/1.2	2.1/1.1	0.07	0.16/0.9

Table III - Parameter list for different DRs

Lattice	PPA	OTW	OCS	BRU	MCH	DAS	TESLA
E [GeV]	5	5	5.066	3.74	5	5	5
Circum [m]	2824	3223	6114	6333	15935	17023	17000
Arc Cell	FODO	TME	TME	FODO	FODO	⚡	TME
ξ (x,y)	-63, -61	-88,-75	-66, -56	-61, -69	-69, -75	-105,-107	-125,-68
ac [e-4]	2.83	3.62	1.59	11.9	4.09	1.14	1.2
tx [ms]	20	12.1	27.6	25.5	26.9	27	28
U0 [MeV]	4.7	8.9	7.5	6.2	19.8	21	21
$\gamma\epsilon_x$ [μm]	4.24	3.80	6.67	2.76	6.60	6.10	8.00
V_{RF} [MV]	18	22	23	54	48	50	50
f_{RF} [MHz]	500	714	500	650	650	500	500
σ_t [mm]	6	6	6	9	9	6	6
Nb [e10]	2	2	2	2	2	2	2
Nbunches	2820	2820	2820	2820	2820	2820	2820
Dt_{bunch} [ns]	3.35	3.82	7.25	7.51	18.90	20.19	20.16
I _{Av} [mA]	955	837	441	426	169	159	159

Dynamic aperture

A large DA is necessary to assure large acceptance and to reduce injection losses. DA calculations have been performed for some of the lattices. The feasibility of a large DA depends on the details of the lattice and the sextupole configuration rather than on the layout. As it is shown in ref.[14] achieving a large DA is more difficult for a dogbone layout, since sextupoles in the arcs must correct the arc and long straight sections chromaticity. However, for example, a 16 Km FODO lattice (MCH) [15] designed as a dogbone showed a large dynamic aperture ($> 10 \sigma_{x,y}$ for $\gamma\epsilon_{x,y} = 0.01$ m) see Fig. 2. Tracking of a realistic positron distribution, produced by a simulation of an undulator positron source, has been done for lattices (MCH, OCS) [15,16]. The injection losses were of the order of 1% for both lattices.

The wigglers used to achieve short damping times can be harmful to the DA. Studies on the effect of wigglers on the damping ring DA have been presented at the "WIGGLE 05" Workshop in Frascati [17]. Different models have been proposed to reproduce measured field distributions and tracking with different wigglers has been performed. A suitable wiggler design can be found to minimize the field nonlinearity and avoid significant DA reduction. This item will require more R&D in the next future.

Kickers

Kickers are definitely the DR system that requires more R&D. Their challenging requirements are listed below:

- Linac pulse frequency 5 Hz,
- Bunch frequency (for 1 ms) 3 MHz
- Deflection angle 0.5 mrad,
- Rise and fall time 20 nsec - 3ns
- Pulse to pulse reproducibility at extraction $\geq \pm 0.07\%$.

If the positrons will be produced by an undulator source, extraction of damped bunches is performed at the same time of injection of new bunches. In this case a large kicker deflection angle is needed for both injection and extraction. By adopting a conventional e^+ source or a pre-DR, this can be avoided and the extraction deflection angle, which has a tight stability constraint, can be much smaller (0.03 mrad).

Kickers R&D is in progress in many laboratories [18]: Strip line kicker and pulser (KEK, SLAC, DESY, LBNL, LLNL, Cornell), Fourier series kicker (FNAL, UIUC), CTF3-like RF deflectors (LNF), crab cavity deflector scheme (Cornell).

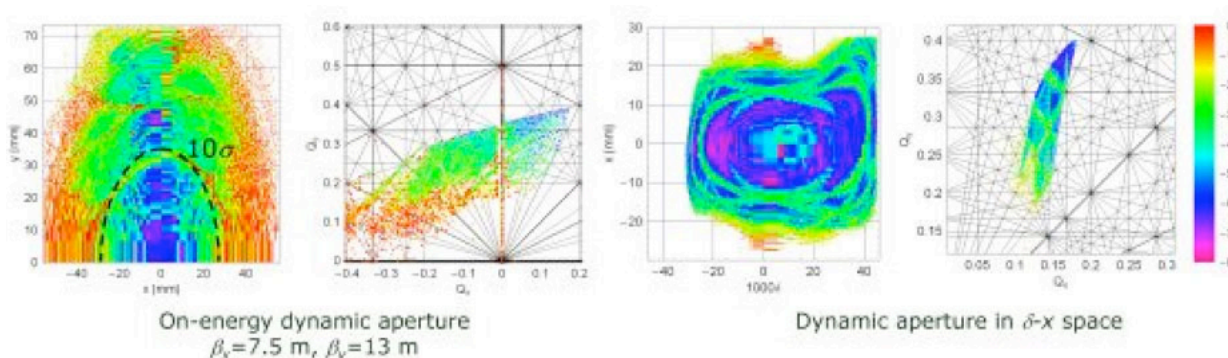

Figure 2: Dynamic aperture of 16 Km dogbone FODO lattice (MCH)

A short pulse stripline kicker powered by a pulser based on Fast Ionization Dynistor (FID) technology has been tested at ATF using turn by turn BPMs [18]. The characteristics are: length 0.33 m, voltage ± 5 KV, kick angle $60 \mu\text{rad}$. The kicker pulse envelope was measured by scanning the pulse timing. A preliminary result is shown in Fig. 3 where a 2.2 ns rise/fall time has been achieved.

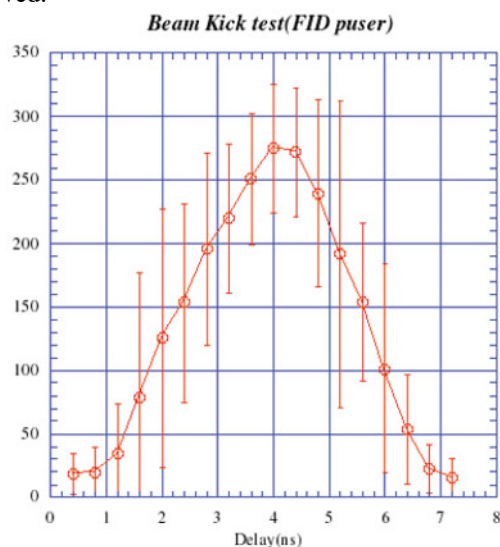

Figure 3: Amplitude of the betatron oscillation as a function of the kicker timing.

BUNCH COMPRESSOR

The job of matching the MDR bunch length requirements to the IP bunch length requirements is performed by a specialized beam line, a "bunch compressor", which reduces the rms bunch length while increasing the rms energy spread. A single stage bunch compressor scheme with a compression factor of 20, from 6 mm to $300 \mu\text{m}$ has been proposed for the TESLA TDR. To keep the maximum rms energy spread small, a two or three stages compressor has been also proposed [20]. It can compress the bunch length down to $150 \mu\text{m}$ allowing for more flexibility in the choice of the collision parameters.

CONCLUSIONS

For the injector system some decisions have still to be taken: the major issues are the positron source, which can be 'conventional' or undulator based, and the DR layout. The tasks needed for injector configuration selection have been identified and assigned in an international collaboration. The intent is to provide the documentation to start the decision process at the 2nd ILC Workshop at Snowmass.

The ILC Baseline Configuration Document should be ready by the end of 2005 and the Complete CDR, including cost and schedule plans should be completed by the end of 2006.

ACKNOWLEDGEMENTS

This paper is based on the work done worldwide by a large number of people. In particular the contributions of G. Dugan, M. Kuriki, A. Wolski, J. Sheppard, J. Clark, T. Maruyama, P. Tenenbaum must be mentioned.

REFERENCES

- [1] [1] 1st ILC Workshop, Nov. 04, KEK (JP) WG3 Injector <http://lcdev.kek.jp/ILCWS/WG3.php>
- [2] T. Raubenheimer, "Suggested ILC Beam Parameter Range", (2005) <http://www-project.slac.stanford.edu/ilc/acceldev/beamparameters.html>
- [3] R. Alley et al., "The Stanford Linear Accelerator Polarised Electron Source", Nucl.Inst. & Meth. A365, (1995).
- [4] The NLC Design Group., "Zeroth Order Design Report for the NLC", SLAC Report 474, pp28-34 (1996).
- [5] "TESLA TDR", DESY 2001-011.
- [6] T. Maruyama, "Polarised Electron Sources Overview", 1st ILC Workshop, Nov. 04, KEK (2004).
- [7] T. Omori "Compton e⁺ source" 1st ILC Workshop, Nov. 04, KEK (JP) WG3 Injector.
- [8] J. Clarke, "Undulator based e⁺ source issues", Workshop on e⁺ sources for ILC, April 05, Daresbury, UK.
- [9] J. Sheppard, "Conventional e⁺ source", Workshop on positron sources for ILC, Apr. 05, Daresbury (UK)
- [10] M. Kuriki, "Polarized e⁺ production and measurement at KEK", Workshop on e⁺ sources for ILC, Apr. 05.
- [11] F. Zimmermann, "Collective effects and instabilities" 1st ILC Workshop, Nov. 04, KEK (JP) WG3 Injector.
- [12] ICFA Lepton Colliders database, http://www.lnf.infn.it/icfa/icfa_db_v8.xls
- [13] A. Wolski et al. "Coupling Correction in the KEK ATF Using ORM Analysis", ATF Report-04-09 (2005).
- [14] Y. Cai, "Dynamic Aperture in DR with realistic Wigglers", "Wiggler Workshop", Frascati, 2005
- [15] A. Wolski, "Lattices with Large Dynamic Aperture for ILC DR", LBNL-57045 (2005).
- [16] L. Emery et al., "Studies Pertaining to a Small DR for the ILC", FERMILAB-TM-2272-AD-TD (2004).
- [17] "Wiggler Workshop", Frascati, 2005, (<http://www.lnf.infn.it/conference/wiggle2005/prog.html>)
- [18] T. Mimashi, "Kickers Overview" 1st ILC Workshop, Nov. 04, KEK (JP) WG3 Injector
- [19] M. Kuriki, "ATF Status", (2005).
- [20] "LET: Bunch Compressor Design Study", <http://www-project.slac.stanford.edu/ilc/acceldev/LET/BC/>