

UDC: 629.735.33

DOI: 10.26467/2079-0619-2020-23-5-67-75

## MATHEMATICAL MODELLING OF AERONAUTICAL ENVIRONMENT

D.E. ESHMURADOV<sup>1</sup>, T.D. ELMURADOV<sup>1</sup>

<sup>1</sup>*Tashkent State Technical University Named After Islam Karimov, Tashkent, Uzbekistan*

On the basis of the study of air flight control, as well as the need to take into account the regional parameters of the airspace, the expediency and the need for mathematical modeling of the air navigation environment were identified. The article deals with the features of the model of air navigation environment, in which the base of the study adopted the basic information used to describe the plan for the execution of air flight. In the study, it was found that in navigation main feature is the geodesic of abstraction, however, such information was found, is not complete for the plan for air flight. The study emphasized the role of taking into account all the restrictions by which certain prohibitions on the use of specific volumes of airspace are imposed. Based on the results obtained, a graph of the geometric representation of the airspace with constraints was constructed. The results of the study allow us to conclude that the construction of a mathematical model of the air navigation environment allows us to achieve the following results: optimization of the distribution of the EAP loads by sectors, visualization of the air navigation situation in the region, the establishment of critical load directions, the collection of data on the load, the study of the factor effects on the regularity and safety of the aircraft movement. The mathematical model of the aeronautical situation was built with the help of a composition of hierarchical type. As a result of such construction of mathematical model its transformation with addition of new models is possible. Using the proposed mathematical model in the framework of discrete event systems can be used to simulate complex air navigation environment with a large number of aircraft. The use of the formalism presented in this study allows a clear distinction between the mechanism of information processing and the information itself in the process of modeling.

**Key words:** modeling, airspace, optimization, mathematical modeling, air navigation, air navigation environment, modeling of air navigation environment.

### INTRODUCTION

Nowadays there is the current point of efficient use of aeronautical environment elements in the conditions of upgrading the performance of the aircraft due to the impact of crisis situations. The air traffic control is becoming more difficult due to the annually increase of the airway congestion. Through the latter there is the increase of the air path workload. The air traffic proceeds over the land environment which is not equipped with the navigational aids. The current research of this point is intended to the real-time system modelling and the preliminary planning of the actual aircraft movement. Nevertheless, the requirements are becoming stricter for the aerospace capacity as a result of convention elements introduction (area navigation RNAV, conditional routes, etc.). Due to that the valence of the airspace area is being increased; its structure is becoming more complicated [1].

The preliminary planning is marked by some points connected with the preliminary flight plans preparation. The proper planning of flights and the consideration of aeronautical environment influence the flight safety. The computer-integrated air navigation environment database is considered to be the source of input data while planning the usage of the airspace. This database ranges all the regional parameters of the air area.

After processing the flight plan of the aircraft by the aviation traffic control system, they estimate the disruption impacts. Before that, it requires the construction of the mathematical model of the aeronautical environment of the aircraft via the use of the formalism of the event-related discrete system with regard to the further changes [2].

In the present research the principles of the event-related discrete modelling and the system dynamics are taken as a basis of the air navigation environment model.

### PROBLEM DESCRIPTION

Nowadays the national carrier “Uzbekiston Havо Yullari” has the great flight geography. The aircraft are equipped with all the necessary navigational aids and operate flights to Europe and America using RNAV system while completing approach.

**Table 1**

Air Traffic Intensity in the airspace of the Republic of Uzbekistan

№	Period	Transit	Airfield Area (departure/arrival)	Total	Deviation (%)
1.	2011	44080	41826	85906	
2.	2012	49110	42950	92060	+ 7
3.	2013	51248	41899	93147	+ 1
4.	2014	54084	40088	94172	+ 1
5.	2015	53965	36891	90856	- 4
6.	2016	54038	34287	88325	- 2,8
7.	2017	55334	34029	89363	+ 1,18
8.	2018	62637	36618	99255	+ 11
9.	2019	58047	44011	102058	+ 2

It can be seen that the air traffic intensity in the airspace of the Republic of Uzbekistan has highly increased. Such rapid growth will demand the air traffic control system infrastructure upgrade, upgraded ATM procedures based on PBN implementation.

It is customary to apply the differential equation system for aeronautical situation mathematical modelling. As for their quantity, it depends on the number of problems which are being solved in the system. The description pattern of aircraft movement is normalized by ICAO and is applied for the description of the flight pln. It contains the following data:

- the expected time of reaching the element
- the flight levels and the flight speed for all the traffic
- the point of flight level change
- the point of airway change
- the sequence of airways used for the aircraft travel
- off and landing time, terminals and alternates and the base airfield
- aircraft type [3]

There are the data of the element features, which compose the plan of the flight, in the air navigation database. Although the airfields are characterized by several parameters, only a few parameters are enough for mathematical modelling and the flight plan interpreting:

- geodesic coordinates of the airport way-point;
- four-letter identification code [4].

At the same time, the airways are presented as the list of the work regulations, vertical limits, navigational aids and points. The waypoints are presented as the distinct five-letter identification codes or the geodesic coordinates. Besides the distinct identification codes and the geodesic coordinates, their physical characteristics which are proceeded by the aircraft aeronautical system [5], are also the features of the aeronautical means. The geodesic abstractions are the only key features of the navigational aids. The aircraft are known to operate flights only within the airways, which are expressed as the certain broken lines. The points of break of such lines are denoted by the navigational aids or points. The availability of all the steer points is not always prescribed by the flight plan. As a result, the interrogation to the aeronautical database is carried out in order to get the exact and relia-

ble data. Due to such an interrogation one can set the geodesic coordinates of the aeronautical means and points which are necessary for modelling the aircraft. Nevertheless, data on the course line of the aircraft are not enough for the planning of the flight to the fullest extent. It is important to take all the restrictions into account while planning. The interdicts on using the certain capacity of the airspace are rolled out by these restrictions. Contingently these restrictions are divided into the following classes:

- 1) the occasional limits, which are of stochastic nature;
- 2) pre-determined limits; data on which is contained in aeronavigation database.

It is needed to refer forbidden areas, hazardous areas, training areas and restricted areas to the pre-determined limits. The enumerated elements of the airspace are defined by the schedule of works and three-dimensional geometrical description (fig. 1) [6]

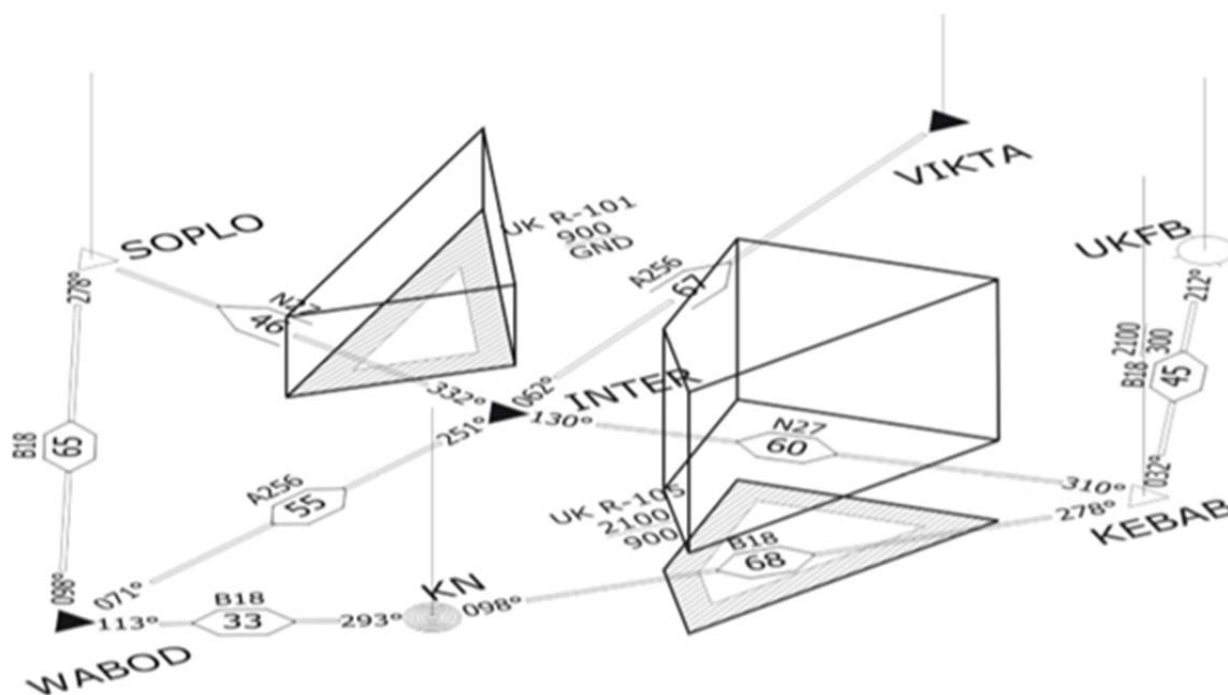

Fig. 1. Geometric representation of restricted airspace

The occasional limits display themselves in a complex of factors: from the impossibility of using some of the airway elements to the closure of some areas in the airspace. As a result, there is a need of separation of the data from the mathematical model. The common data repository can be used for all the problems related to the traffic control with the help of such separation. In particular, one can take the local basis into account [7].

Analyzing the traffic above the territory of the Republic of Uzbekistan, one can notice that there are around 200 aircraft per shift travelling along the more congested airway. Therefore, the night time is especially harsh to the air traffic control officer. For instance, at 3 a.m. there are around 20 aircraft per unit of time over the point of TMD (Tamdibulak) [8].

Construction of mathematical modes of aeronautical environment in the objective point by taking the problem description into account can be used for obtaining the following results:

- the optimization of airspace load distribution between the areas;
- the survey (visualization) of aeronautical environment in the region for its descriptive research;
- the opportunity of setting the stalling directions in terms of the workload;

- the analysis and statistical data collection on the highest workload on the areas of the airways and in the separate areas;
- the opportunity of researching the impact of the different occasional factors on safety and regularity of the air traffic.

## THE RESULTS OF THE RESEARCH

Although the process of the aeronautical environment change is considered to be constantly ongoing and ram through time, it is needed to use the following variants:

- 1) no need of modelling the aeronautical environment change in real-time mode;
- 2) the airspace structure change may affect the modelling object;
- 3) the change of states of the airspace structure of the stochastic nature;
- 4) the aerodynamic factors reflect the state of the aircraft model at any moment of time. Taking them into account is not necessary in terms of solving the following problems;
- 5) the description of the traffic of every single aircraft using the system of differentiated equations is difficult as a result of a big number of objects being modelled.

The structure of a system depends on the character and typology of correlation of its elements. Consequently, the performance of a system needs to be matched with its current states. Each of these states can be expressed in terms of many variables; the multitude of these variables depends on the system. For instance, temperature, volume and pressure are the variables for the definition of the thermodynamic system; that means that ephemerides of the celestial bodies are needed to define the state of the astronomic system. The elements of the system may be of the complex or atomic nature. In their turn, the terms “complexity” and “atomicity” are considered to be conventional imposed by the problems of modelling. For instance, directional beacon is modelled as an atomic system object while modelling the procedures of landing of the aircraft. At the same time, it is needed to analyze the compound element in order to research the work of the wave guides of this radio homing beacon. The compound element includes functional “atomic” clusters which are differentiated to separate elements of the schemes, etc.

Discrete systems in general cases are divided into discrete time systems and systems of a constant time interval [9]. The change of a system state of a constant time interval is provided in terms of a constant time interval  $\Delta t$ . The amounts of the variables, which reflect the system state, do not change in the intervals between the  $\Delta t$  observation. If  $\Delta t$  tends to zero, such a mathematical model can be used for duplication of a process of a constant nature. The process of changing the states of the discrete time systems is implemented by means of different time intervals. Their duration may be related to the environment. The change of the system states is expressed in the mishaps.

The description of the systems of the object hierarchical synergy is provided by the mathematic modelling of the mishap schemes. [10]. It was offered in 1976 by B. Zigler. The input data, unlike the continuous systems, do not change due to time in the mishap discrete system by the law of step function. Such a formalism has some benefits, which are conditioned by inheritance of the mathematical theory of the systems of the dynamical nature [11]. The following formalism of the mathematical modelling allows to combine the elements of the discrete and continuous paradigms in terms of the object being modelled. One more significant benefit is the opportunity of synthesis of the mathematical model by combining the atomic objects to the more complicated ones. It is worth empathizing that the derived objects may be used in modelling the objects of a more sophisticated nature. The hierarchic structure made this way is considered to be the composition “tree”. The offered formalism of the mathematical modelling by the following feature is different from any other current methods used while modelling the processes of air traffic management because the structure of the object being modelled is changing dynamically. The effect of each different conventional is taken into account while solving the following problem. That means that the restrictions on using the airspace are activat-

ed; the effect of the crisis factors also take place. The structure is being modified while proceeding such conventional factors and modelling.

There is a few of enumerations of models in the classification of the objects. These models are presented in Figure 2.

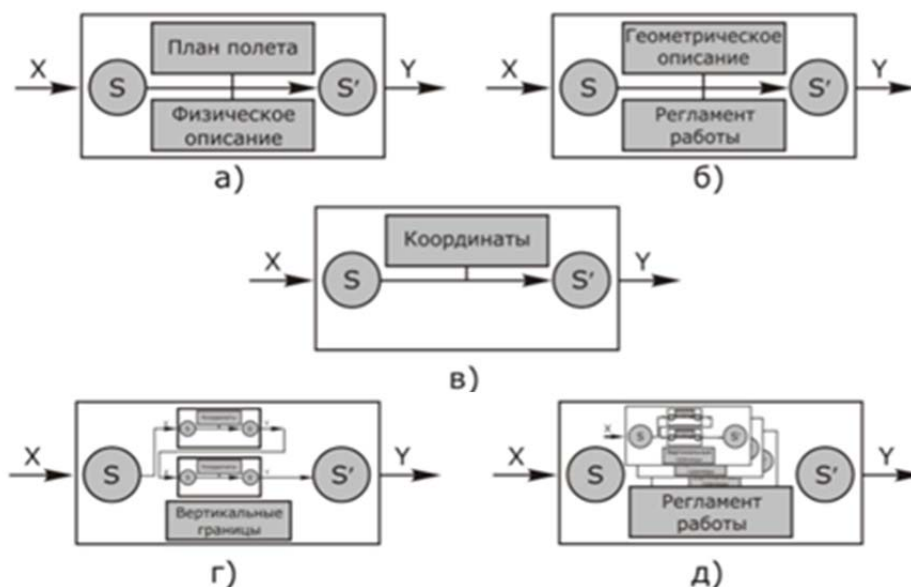

Fig. 2. Model hierarchy

Thus, there are the following models in this hierarchy:

1. The model of the aircraft: the inner physical interpretation is being changed depending on the type of the aircraft (helicopter, jet aircraft, piston aircraft, etc.), but the input and output data do not vary for the models of any aircraft (fig. 2a).

2. The model of the flight restriction; includes all the enumerated types of models (fig. 2б).

3. The model of the navigational aids or of the waypoint (fig. 2в).

4. The model of the section of the airway (fig. 2г).

5. The model of the airway (fig. 2д).

The models presented in Figures 2a–2в are considered to be atomic in the following system. At the same time, there are the complex models in Figures 2г–2д.

The system model can be described in a general case this way:

$$M = (X, S, Y, \delta in., \delta ext., \lambda, ta), \quad (1)$$

where  $ta : S \rightarrow Real$  is the function which defines the ultimate time of the system being in the current state;

$\lambda : S \rightarrow Y$  is the function of the enteral mishaps generating;

$\delta ext. : Q \times X \rightarrow S$  is the enteral function of the transition. It defines the transition of states which is conditioned by the effect of the enteral mishaps, where:

$Q = \{(s, e) | s \in S, 0 \leq e \leq ta(s)\}$  is the vector of time of the system being in this state;

$\delta вн. : S \rightarrow S$  is the inner function of the transition. It defines the transition of states conditioned by the inner mishaps;

$Y$  is the multitude of the outgoing mishaps;

$S$  is the multitude of states which change in sequence;

$X$  is the multitude of the entering mishaps.

## THE DISCUSSION OF THE RESULTS

Using of the formalism of the mishap discrete systems for solving the basic problems of the flight planning can be illustrated by the simple examples. The following formalism can be used for the mathematical modelling of the complicated aeronautical environment equipped with a plenty of navigational aids. The opportunity of multipartition of the mathematical model and the basic data on the elements of the modelling system is the most ultimate factor while modelling the complicated aeronautical environment. Using the formulae presented in this work allows to divide exactly the mechanisms of the data proceeding and the data itself while modelling.

Besides that, the opportunity of adding the new models to the simulator of the developed mathematical model is its significant benefit. In spite of the following benefit, the formulas presented in this work can also be used for the mathematical modelling of the systems which are of the constant time interval. It is worth empathizing that the time interval is chosen while taking the peculiarities of the modelling process problem into account. For instance, one can use the discrete «1 step – 1 minute» in order to solve the problem of planning because all the time intervals are set with such a time accuracy for description of the procedures of the restriction zones and the flight plan. At the same time, the discrete step – «1 second» will be the one for the problems of modelling the near collisions, because the aircraft travels the distance in 1 second 250 meters having the average rate of 900 km per hour, which yields the standards of the horizontal separation.

The virtual model is easily discretized for the direct motion:

$$\begin{aligned} S_{n+1} &= S_n + \frac{V_{n+1} + V_n}{2} \cdot \Delta t \\ V_{n+1} &= V_n + a_{n+1} \Delta t . \end{aligned} \quad (2)$$

The development of the following formalism is used hereinafter to the paralleling formalism of the mishap discrete systems [12], which allows it to be used in the distributional computation resources.

## CONCLUSION

As a result of the mathematical modelling by the hierarchical compositions, one can implement the current methods of the object-based programming using the modelling of the aeronautical environment. Hereinafter the results of modelling can be embedded in the agencies of the flight planning.

## REFERENCES

1. **Lyudomir, A.V. and Orlov, V.S.** (2014). *Simulation of dynamical environment in controlled airspace*. Journal of Applied Informatics, no. 5 (53), pp. 89–97. (in Russian)
2. **Tel'puhovskaya, O.N.** (2017). *The modeling of air situation using object-oriented programming system*. Civil Aviation High Technologies, vol. 20, no. 4, pp. 107–113. DOI: 10.26467/2079-0619-2017-20-4-107-113. (in Russian)
3. **Kiselev, V.Yu. and Monakov, A.A.** (2015). *Aircraft trajectory prediction in air traffic control systems*. Information and Control Systems, no. 4 (77), pp. 33–40. (in Russian)
4. **Belyaev, Yu.B., Shmeleva, T.F., Kud, P.P. and Vlasov, S.A.** (2007). *Modelirovaniye zadach planirovaniya dvizheniya aviatsionnogo transporta v usloviyakh vysokodinamichnoy struktury vozdušnogo prostranstva s ispolzovaniyem formalizma diskretnykh situatsiy* [Modeling of air transport traffic planning problems in conditions of highly dynamic airspace structure with the use of discrete situations formalism]. Elektronnyy arkhiv Kiyevskogo Natsionalnogo universiteta

pishchevykh tekhnologiy, 10 p. Available at: [http://dspace.nuft.edu.ua/jspui/bitstream/123456789/3478/1/Belyaev\\_2.pdf](http://dspace.nuft.edu.ua/jspui/bitstream/123456789/3478/1/Belyaev_2.pdf) (accessed 10.07.2020). (in Russian)

5. **Gabeidoulin, R.Kh.** (2016). *Matematicheskoye modelirovaniye metodov regulirovaniya vozdushnogo dvizheniya s uchetom nedostovernosti prognoza vozdushnoy obstanovki* [Mathematical modeling methods of regulation of air traffic, taking into account the unreliability of the forecast of air environment]. *Grazhdanskaya aviatsiya na sovremennom etape razvitiya nauki, tekhniki i obshchestva: sbornik tezisov dokladov uchastnikov Mezhdunarodnoy nauchno-tekhnicheskoy konferentsii, posvyashchennoy 45-letiyu Universiteta* [Civil aviation at the present stage of development of science, technology and society: a collection of abstracts of the participants of the International Scientific and Technical Conference devoted to the 45th anniversary of the University], p. 174. (in Russian)

6. **Wybo, S.** (2003). *Database delivery*. Air Traffic Technology International, pp. 40–42.

7. **Zolotukhin, V.V., Isayev, V.K. and Davidson, B.Kh.** (2009). *Nekotorye aktualnyye zadachi upravleniya vozdushnym dvizheniyem* [Some actual problems of air traffic control]. *Trudy MFTI*, vol. 1, no. 3, pp. 94–114. (in Russian)

8. **Eshmuradov, D.E. and Sayfullaeva, N.A.** (2020). *Questions of optimization of the distribution of downloads of air space by sectors*. *Teoriya i praktika sovremennoy nauki*, no. 4 (58), pp. 201–204. (in Russian)

9. **Muromtsev, D.Yu. and Yashin, Ye.N.** (2012). *Analiz i sintez diskretnykh system: uchebnoye posobiye* [Analysis and synthesis of discrete systems: Tutorial]. Tambov: Izdatelstvo FGBOU VPO “TG TU”, 120 p. (in Russian)

10. **Mikhaylov, D.D.** (2015). *Osnovy matematicheskogo modelirovaniya* [Fundamentals of mathematical modeling]. *Bulletin of the Technological University*, no. 2, pp. 374–376. (in Russian)

11. **Shpakov, V.M.** (2017). *About situation-event approach to control of interacting discrete-continuous processes*. *Information and Control Systems*, no. 2 (87), pp. 26–33. DOI: 10.15217/issnl684-8853.2017.2.26. (in Russian)

12. **Chow, A.C., Zeigler, B.P. and Kim, D.H.** (1994). *Abstract simulator for the parallel DEVS formalism*. Fifth Annual Conference on AI and Planning in High Autonomy Systems, Gainesville, FL, USA, pp. 157–163. DOI: 10.1109/AIHAS.1994.390488

## INFORMATION ABOUT THE AUTHORS

**Dilshod E. Eshmuradov**, Academician of the Academy of Sciences Turon, Candidate of Technical Sciences, Associate Professor of the Department of Metrology, Standardization, Certification, Tashkent State Technical University Named after Islam Karimov, [e\\_dilshod69@mail.ru](mailto:e_dilshod69@mail.ru)

**Temurmaliq D. Elmuradov**, Assistant, Department of Informatics and Information Technology, Tashkent State Technical University Named after Islam Karimov, [e\\_dilshod69@mail.ru](mailto:e_dilshod69@mail.ru).

## ПОСТРОЕНИЕ МАТЕМАТИЧЕСКИХ МОДЕЛЕЙ АЭРОНАВИГАЦИОННОЙ ОБСТАНОВКИ

Д.Э. Эшмурадов<sup>1</sup>, Т.Д. Элмурадов<sup>1</sup>

<sup>1</sup>Ташкентский государственный технический университет им. Ислама Каримова,  
г. Ташкент, Узбекистан

На основе проведенного исследования управления воздушными полетами, а также необходимости учета региональных параметров воздушного пространства была выявлена целесообразность и необходимость проведения математического моделирования аэронавигационной обстановки. Рассматриваются вопросы особенностей построения модели аэронавигационной обстановки, в рамках которых в базу исследования приняты основные сведения, используемые для

описания плана по исполнению воздушного полета. В рамках исследования было установлено, что у навигационных средств основной особенностью считаются геодезические абстракции, однако такие сведения, как было установлено, не являются полными для осуществления планирования воздушного полета. В исследовании была подчеркнута роль учета всех ограничений, с помощью которых вводятся некоторые запреты на использование конкретных объемов воздушного пространства. На основе полученных результатов был построен график геометрического представления воздушного пространства с ограничениями. Результаты проведенного исследования позволяют прийти к выводу о том, что построение математической модели аэронавигационной обстановки позволяет достичь следующих результатов: оптимизация распределения грузовок воздушного пространства по секторам, визуализация аэронавигационной обстановки региона, установление критических направлений загруженности, сбор данных о загруженности, исследование факторных воздействий на регулярность и безопасность движения воздушного судна. Математическая модель аэронавигационной обстановки была построена с помощью композиции иерархического типа. В результате такого построения математической модели возможна ее трансформация с добавлением новых моделей. Использование предложенной математической модели в рамках событийных дискретных систем может являться для моделирования сложной аэронавигационной обстановки с большим количеством воздушных судов. Использование формализма, представленного в настоящем исследовании, позволяет четко разграничить механизм обработки информации и саму информацию в процессе осуществления моделирования.

**Ключевые слова:** моделирование, воздушное пространство, оптимизация, математическое моделирование, аэронавигация, аэронавигационная обстановка, моделирование аэронавигационной обстановки.

### СПИСОК ЛИТЕРАТУРЫ

1. Людомир А.В., Орлов В.С. Имитационное моделирование динамической воздушной обстановки в управляемом воздушном пространстве // Прикладная информатика. 2014. № 5 (53). С. 89–97.
2. Тельпуховская О.Н. Моделирование воздушной обстановки с использованием объектно-ориентированной системы программирования // Научный Вестник МГТУ ГА. 2017. Т. 20, № 4. С. 107–113. DOI: 10.26467/2079-0619-2017-20-4-107-113
3. Киселев В.Ю., Монаков А.А. Предсказание траектории воздушного судна в автоматизированных системах управления воздушным движением // Информационно-управляющие системы. 2015. № 4 (77). С. 33–40.
4. Беляев Ю.Б. Моделирование задач планирования движения авиационного транспорта в условиях высокодинамичной структуры воздушного пространства с использованием формализма дискретных ситуаций [Электронный ресурс] / Ю.Б. Беляев, Т.Ф. Шмелева, П.П. Кудь, С.А. Власов // Электронный архив Киевского Национального университета пищевых технологий. 2007. 10 с. URL: [http://dSPACE.nuft.edu.ua/jspui/bitstream/123456789/3478/1/Belyaev\\_2.pdf](http://dSPACE.nuft.edu.ua/jspui/bitstream/123456789/3478/1/Belyaev_2.pdf) (дата обращения 10.07.2020).
5. Габейдулин Р.Х. Математическое моделирование методов регулирования воздушного движения с учетом недостоверности прогноза воздушной обстановки // Гражданская авиация на современном этапе развития науки, техники и общества: сборник тезисов докладов участников Международной научно-технической конференции, посвященной 45-летию Университета. Москва 18–20 мая 2016 г. М.: Академия им. Н.Е. Жуковского, 2016. С. 174.
6. Wybo S. Database delivery // Air Traffic Technology International. 2003. С. 40–42.
7. Золотухин В.В., Исаев В.К., Давидсон Б.Х. Некоторые актуальные задачи управления воздушным движением // Труды МФТИ. 2009. Т. 1, № 3. С. 94–114.
8. Эшмурадов Д.Э., Сайфуллаева Н.А. Вопросы оптимизации распределения грузовок воздушного пространства по секторам // Теория и практика современной науки. 2020. № 4 (58). С. 201–204.
9. Муромцев, Д.Ю., Яшин Е.Н. Анализ и синтез дискретных систем: учеб. пособие. Тамбов: Изд-во ФГБОУ ВПО «ТГТУ», 2012. 120 с.
10. Михайлов Д.Д. Основы математического моделирования // Вестник Казанского технологического университета. 2015. Т. 18, № 2. С. 374–376.



**11. Шпаков В.М.** О ситуативно-событийном подходе к управлению взаимодействующими дискретно-непрерывными процессами // Информационно-управляющие системы. 2017. № 2 (87). С. 26–33. DOI: 10.15217/issnl684-8853.2017.2.26

**12. Chow A.C., Zeigler B.P., Kim D.H.** Abstract simulator for the parallel DEVS formalism // 5th Annual Conference on AI and Planning in High Autonomy Systems, Gainesville, FL, USA, 1994. Pp. 157–163. DOI: 10.1109/AIHAS.1994.390488

### СВЕДЕНИЯ ОБ АВТОРАХ

**Эшмурадов Дилшод Эльмурадович**, академик Академии наук Турон, кандидат технических наук, доцент кафедры метрологии, стандартизации, сертификации Ташкентского государственного технического университета им. Ислама Каримова, e\_dilshod69@mail.ru.

**Элмурадов Темурмалик Дилшодович**, ассистент кафедры информатики и информационных технологий Ташкентского государственного технического университета им. Ислама Каримова, e\_dilshod69@mail.ru.

Поступила в редакцию 14.07.2020  
Принята в печать 24.09.2020

Received 14.07.2020  
Accepted for publication 24.09.2020