

## Development of Elementary Cell module for the EUSO Focal Surface Detector

Y. Takizawa<sup>a</sup>, Y. Kawasaki<sup>a</sup>, M. Sato<sup>a</sup>, M.E. Bertaina<sup>a</sup>, T. Ebisuzaki<sup>a</sup>, H. M. Shimizu<sup>a</sup>, T. Sawabe<sup>b</sup>, F. Kajino<sup>b</sup>, I. Sato<sup>c</sup>, H. Takara<sup>c</sup>, N. Isono<sup>c</sup>, M. Ameri<sup>d</sup>, S. Cuneo<sup>d</sup>, F. Fontanelli<sup>d</sup>, V. Gracco<sup>d</sup>, P. Musico<sup>d</sup>, M. Pallavicini<sup>d</sup>, A. Petrolini<sup>d</sup>, M. Sannino<sup>d</sup>, F. Siccardi<sup>d</sup>, A. Thea<sup>d</sup> and EUSO Collaboration

(a) RIKEN, 2-1 Hirosawa, Wako 351-0198, Japan

(b) Department of Physics, Konan University, Kobe 658-8501, Japan

(c) Meisei Electric Co., Ltd, 2-5-7, Koishikawa, Bunkyo-Ku, Tokyo 112-8511, Japan

(d) Dipartimento di Fisica dell'Università and INFN, 16146 Genova, Italy

Presenter: Y. Takizawa (takky@riken.jp), jap-takizawa-Y-abs1-he15-poster

The Focal Surface detector of EUSO (Extreme Universe Space Observatory) consists of small autonomous functional units (elementary cell, EC) assembled in larger modules (Photo Detector Modules, PDM). Each EC is conceived as an array of 4 multianode photomultipliers (MAPMTs). We have developed EC structure for the current baseline of the multianode photomultiplier (MAPMT, R8900-M36). As the mechanical characteristics of the PDM structure (e.g. robustness to thermal and launch shocks, vibrations at launch) will affect the EC structure, we have also built a trial PDM, consisting of 36 MAPMTs (9 ECs) arranged in a cartesian layout. The purpose of such trial PDM is to develop and optimize the EC structure.

### 1. Introduction

EUSO is a science mission to detect Extremely High Energy Cosmic Rays at energies  $E > 10^{20}$  eV. It is a super wide-field telescope that observes UV photons from air showers produced by cosmic rays in the night side of the Earth. EUSO will be attached to the Columbus module of the International Space Station (ISS). EUSO is a collaborative effort among scientists of Europe, USA, and Japan. The phase-A study (conceptual design) under ESA has been successfully finished in July 2004[1] and the international negotiations for phase-B (detailed design) are in progress. The EUSO telescope, which diameter is 2.5m, comprises of a pair of double-sided curved Fresnel lenses with a curved focal surface and the electronics. Its field of view is  $60^\circ$  with  $f/\# = 1.25$  and the angular resolution of the optics is at the order of  $0.1^\circ$  in Phase-A baseline design.

### 2. The focal surface detector

The focal surface detector is a closely packed mosaic of MAPMTs approximating the curved focal surface. Near-ultraviolet photons (300 nm ~ 400 nm) are selectively delivered onto the focal surface detector by employing optical filters on top of the detector. Hamamatsu R7600 series MAPMT with UV-glass entrance windows had been indicated as baseline photo-detector at the beginning of Phase-A. However, these types of MAPMT have a large dead area and the sensitive area ratio is only about 45%. The Japan team has developed a new type of MAPMT, Hamamatsu R8900 series, to enlarge the sensitive area ratio of the MAPMT. R8900 series are modified from R7600 series by introducing a grid between the photocathode and the first dynode to electrostatically demagnify the photoelectron image onto the dynode[2]. The average sensitive area increases up to 83% of its physical dimension. The small dead area can be removed rather easily. One possible method is to employ a tapered light guide on top of the MAPMT. An example is shown in Figure 1. An estimation obtained using the tapered BG-3 filter gives a sensitive area ratio higher than 93% over the whole elementary cell (EC), which is described in the next section. The entire pixel array on the focal surface will be configured

as an array of clustered pixels. The schematic of the focal surface is shown in Figure 2. We refer to the pixel cluster as the Photo Detector Module (PDM). The PDM size will be chosen so that most of the air shower tracks will be fully contained in one PDM.

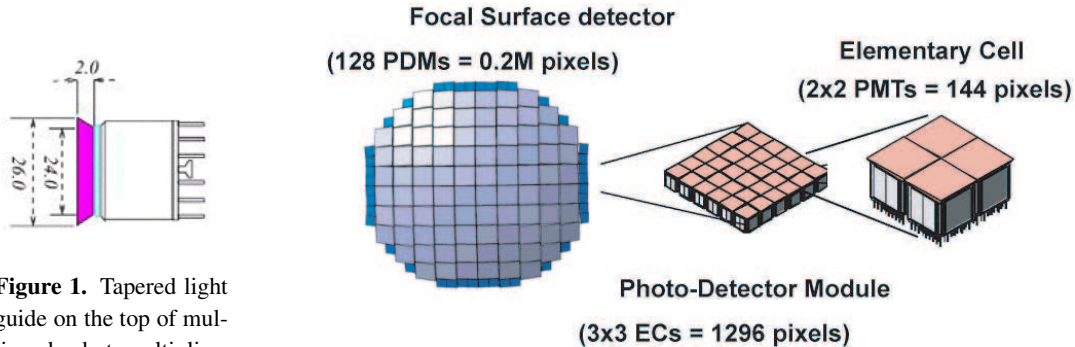

**Figure 1.** Tapered light guide on the top of multi-anode photomultiplier.

**Figure 2.** The focal surface detector configuration.

### 3. Development of the Elementary-Cell

By the Phase-A definition, "Each elementary-cell contains four units of MAPMT R8900, additional optical adapters to increase its physical detection area, HV/LV power connectors, one HV voltage divider for any of the MAPMT units, common heat dissipation facilities, common miscellaneous services and monitoring devices, all of the Front-End electronics plus as much as possible of the trigger/read-out electronics integrated in the EC and connectors for signal transmission and control lines."

INFN team has developed successfully the EC Prototype by using R7600 in the Phase-A work[3][1]. The four MAPMT units are located on a base-board together with the passive electronics of the voltage dividers, and the MAPMT can be inserted in the upper part of the socket. The lower part of the socket contains a ball grid array (BGA) that is soldered to the EC board. INFN's method will be suitable for the Flight model. As the additional step, we are searching other possibility of EC design as a backup solution. So, Japan team and Meisei electric co.,ltd. are developing the EC module structure for the current base line R8900-M36 MAPMT under the supervision of the INFN team. Additionally, we have developed the trial PDM, "trial" means this PDM is not prototype model, because it is necessary to know the characteristics of PDM to decide the structure of EC. The specifications of the EC and trial PDM are described in the followings and Figure 5:

1. The four R8900-M36 MAPMT units are located on a EC board.
2. The vibration tolerance level of EC is random 20 G rms, 120 sec, for X, Y and Z axis. A method of MAPMT mount is that MAPMT bottom surface touches EC base surface. Pins of MAPMT go through holes on the EC base. This method staves off glass seals of pins being broken by vibration. See Figure 3.
3. The distance of each optical adaptor's top is 0.5 mm.
4. EC has flexible readout cables to connect the PDM daughter circuit board. We selected the easy readout method by using flexible cables connection, because the BGA connecting technique was established by Italian team. The ASIC has to be as close as possible to the MAPMT, because we need a fast time response and the connections have a non-negligible capacitance. So, The BGA connecting method will be suitable for the EUSO Flight model.
5. The vibration tolerance level of trial PDM is random 20 G rms, 120 sec, for X, Y and Z axis.
6. Trial PDM has 3x3 ECs (9ECs = 36 MAPMTs).

7. Trial PDM has a HV supply circuit, which distributes to high voltage to 36 MAPMTs[4].
8. Trial PDM has 3 daughter circuit board.
9. A daughter board takes in 3 ECs, has 3 HV divider circuits and readout connectors. Each divider circuit takes in 1 EC (4 MAPMTs).

Prototypes of the EC and trial PDM were built as shown in Figure 4 and Figure 6. We will test these performance in the FY 2005. The overall vibration test was done on 20 June, 2005. EC and trial PDM survived from random 20 G rms vibration test, 120 sec, for X, Y and Z axis.

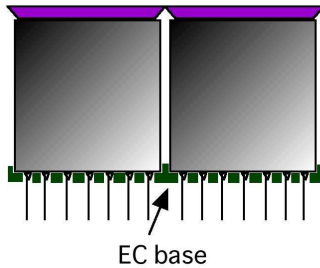

**Figure 3.** How to fix MAPMT on the EC base. MAPMT bottom surface touches EC base surface to withstand random 20 G rms vibration level.

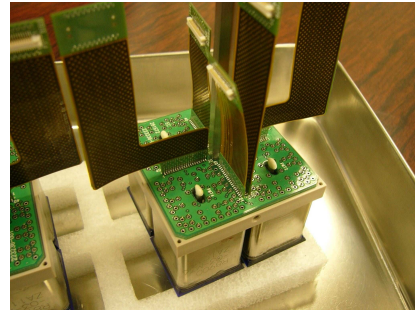

**Figure 4.** EC and flexible read out cables.

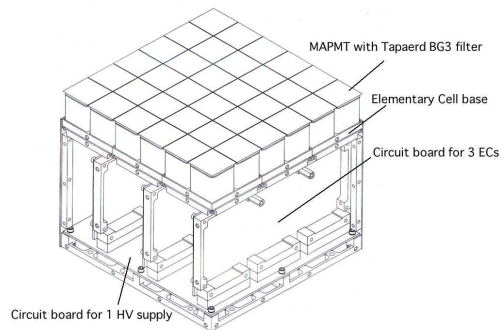

**Figure 5.** Schematic picture of Trial PDM module and EC design

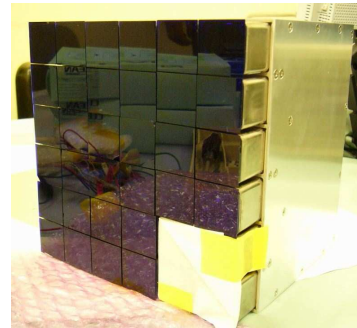

**Figure 6.** Trial X-Y layout PDM

#### 4. Conclusions

We have developed successfully EC prototype development by using R7600 in the Phase-A work. As supported work, we are developing the EC module structure for the current baseline R8900-M36 MAPMT and the trial PDM model. the EC and trial PDM survived from random 20 G rms vibration test, 120 sec, for X, Y and Z

axis. And furthermore, we will test (e.g. robustness to thermal and launch shocks) in the FY 2005. The results will be reflected in the Phase-B detail design.

## **5. Acknowledgements**

This study is partially supported by the "Grants-in-aid President's Discretionary Fund" promoted by RIKEN.

## **References**

- [1] EUSO Collaboration, EUSO Report on the Phase A study (2004).  
<http://www.euso-mission.org/>.
- [2] Y. Kawasaki et al, This conference proceedings (2005).
- [3] M. Ameri et al, 28th ICRC proceedings,939-942 (2003).
- [4] F. Kajino et al, This conference proceedings (2005).