

A novel wavelength shifter foil for IceCube

E. Resconi^a, D. Bertrand^b, M. Errando^c, G. Hermann^d, R. Nahnauer^a,
S. Schönert^d, C. Spiering^a and O. Tarasova^a

(a) DESY, Platanenallee 6, D-15738 Zeuthen, Germany.

(b) ULB-IIHE-CP230, Boulevard du Triomphe B-1050 Bruxelles.

(c) Institut de Física d'Altes Energies, 08193 Bellaterra, Spain.

(d) Max-Planck-Institut für Kernphysik, Saupfercheckweg 1, D-69117 Heidelberg.

Presenter: Nahnauer, Rolf (rolf.nahnauer@desy.de), ger-nahnauer-R-abs2-og25-poster

The IceCube optical modules are composed of a photomultiplier tube encapsulated in a glass sphere. The encapsulating glass is transparent for photons with a wavelength greater than 330 nm. Therefore, the part of the Cherenkov spectrum below this cut-off does not contribute to the signal production even if the medium in which these photons are generated is transparent down to 250 nm at least. Thus, the collection efficiency is not yet as high as desirable. We investigated the use of a wavelength shifter layer placed outside the lower hemisphere of the optical modules. The development of a novel wavelength shifter (WLS) has been motivated by the limitations of commercial available materials. In this paper, we report measurements of the improvement in light collection efficiency obtained with a wavelength shifter working in air and in water.

1. Introduction

IceCube is a cubic kilometer detector to be installed deep in the clear Antarctic ice sheet at the Amundsen-Scott South Pole Station. IceCube will reconstruct neutrino events from the Cherenkov radiation pattern of the charged particles produced in the interactions of neutrinos. The IceCube neutrino observatory will consist of an array of 4800 Digital Optical Modules (DOMs) frozen into the deep ice, and an air shower array of 320 DOMs housed in 160 ice tanks on the surface above the detector. A 10" photomultiplier tube (PMT) is enclosed in each DOM for the detection of the Cherenkov light.

The aim of this work is to extend the sensitivity of IceCube DOMs below the cutoff imposed by the encapsulating glass of the PMT at ~ 330 nm. This effort has been motivated by the transparency of the ice sheet surrounding IceCube down to 250 nm [1] and by the proportionality of the Cherenkov spectrum to $1/\lambda^2$. The ambition is to obtain a significant enhancement in the light collection efficiency and an improvement in IceCube performances. Previous works on this topic are reported in [2].

Commercial available wavelength shifting materials have various shortcomings. Wavelength shifting dyes (WLS-dyes) used with transparent acrylic polymer substrates suffer from the fact that the substrate material absorbs photons with a wavelength smaller than approximately 300 nm, is rigid but brittle and its elongation at rupture is a few percents only. Furthermore, it has a poor low temperature and fatigue resistance and its processing temperature is high ($\sim 250^\circ\text{C}$). On the other side, WLS-dyes used with styrene polymer substrates are limited due to the fact that an energy transfer from the polymer to the WLS-dye is required. The index of refraction of polystyrene is 1.58 and thus greater than the index of refraction of a typical glass. Moreover, in case only UV-photons have to be detected, these polymers are limited since they emit scintillating light when ionizing radiation passes through. The development of a new WLS has been motivated following the discussed limitations of commercial available materials.

The novel material (called THV-WLS) uses an organic WLS-dye in conjunction with a fluorothermoplastic substrate named THV. The dye selected for this specific application is 2,5-Diphenyloxazol (PPO). THV-WLS is sensitive down to 200 nm, it has a high quantum yield, it stays flexible also at low temperature, it is water

compatible and it is cost effective. Moreover, it is possible to extrude, thermoform and weld the THV-WLS without optical deteriorations. This means that the THV-WLS can be used in a variety of shapes and thicknesses. A detailed description of the production steps and of the optical properties of the THV-WLS is reported in [3],[4].

In this paper, we review the measurements of the relative quantum efficiency (QE) of the DOM equipped with a THV-WLS sample. Two complementary sets of measurements have been performed: (A) a differential one for the study of effects like the geometrical acceptance of the photons and the total internal reflection, (B) an integral one for the estimation of the overall improvement in light collection efficiency. Details of the two methods are reported below.

2. Method A: Monochromatic Light Source

A survey of the THV-WLS behavior in various medium (air, water) has been performed in order to determine the total internal reflection (TIR) component and to study effects like solid angle dependence, isotropy of the re-emitted light, uniformity of the foil. A simplified geometry and a monochromatic light source have been used. For space reasons, only the measurement of the TIR is reported here.

After absorption of a UV photon by the WLS-foil in optical contact with the DOM, a photon with a longer wavelength (wavelength shifted photon) is emitted isotropically. The fraction of photons emitted inside the solid angle Ω covered by the PMT will directly contribute to the signal, while the rest would be in principle lost. However, the photons falling outside Ω have a probability P to be reflected by TIR and to contribute to the signal. P depends on the ratio n_{foil}/n_{medium} where $n_{foil} = 1.35$ is the refractive index of the THV-WLS and n_{medium} is the refractive index of the medium which surrounds the DOM. A schematic view of the system is shown in Fig. 1a. The TIR is expected to give a significant contribution to the signal when the foil operates in air and is expected to be irrelevant when the foil is in water.

The experimental setup used for these measurements is placed at the Max-Planck-Institute for Nuclear Physics in Heidelberg (Germany). The light source is an arc xenon lamp coupled with a double monochromator. The output of the monochromator is directly coupled to a quartz fiber that leads the light into a dark box. The light can be attenuated before entering the box with the use of a filter wheel. At the entrance of the box a quartz diffuser has been placed in order to maximize the homogeneity of the light field inside the box. The light detector is a bi-alkali 8-stage photomultiplier tube with 25 mm photocathode diameter. The spectral sensitivity ranges from 270 nm to 650 nm with a maximum at 420 nm. The calibration of the light flux has been performed using a calibrated silicon photodiode. The whole system has an uncertainty of 2% on the light intensity and 0.5 % in linearity. The "air" measurements are performed with THV-WLS foil in optical contact with the PMT. The "water" measurements are obtained with the foil immersed in distilled water in a 1 mm quartz cuvette which is optically coupled with the PMT. The foil is illuminated through a 1mm hole to have the closest situation to a point-like light source and avoid additional geometrical effects.

The QE of the system has been obtained measuring the anode current as a function of the wavelength. The curve is normalized to a QE of 25% at 400 nm. Results are reported in Fig. 1b. As expected, the THV-WLS does not influence the detection efficiency above 370 nm. We determine the TIR contribution from the values of the QE below 330 nm. These values are obtained with the foil operating in different configurations. The result is that the TIR component contribute to the QE measured in air by a factor 0.2-0.4.

3. Method B: Cherenkov Light Source

The use of THV-WLS directly coupled with a DOM leads to an improvement in light collection efficiency. Two different experimental setups and a Cherenkov light source are used in order to quantitatively estimate this effect.

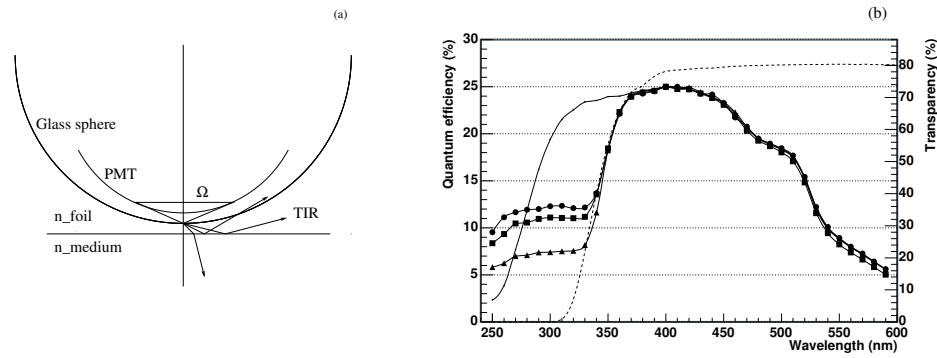

Figure 1. (a) Schema of various light-paths. The TIR effect is visualized with the foil represented like a flat layer at a certain distance. In reality, the foil is shaped and optically coupled with the encapsulating sphere. (b) QE of the system PMT and THV-WLS in different configurations: (continue line) QE of the PMT not equipped with THV-WLS, (dotted line) transparency of the encapsulating glass, (dots) THV-WLS in air directly coupled with the PMT, (squares) THV-WLS in the 1 mm cuvette not filled with water, (triangles) THV-WLS in the 1 mm cuvette filled with distilled water.

In the setup used at ULB in Brussels, the Cherenkov light is produced by cosmic muons passing through a glass tank ($40 \times 80 \times 10 \text{ cm}^3$) filled by demineralised water and inclined at 49° (see Fig. 2a). The trigger is produced by a set of 3 scintillators: 2 above the tank and 1 below after a lead wall. The showers are vetoed by a fourth scintillator placed above the OM. The OM is positioned in front of a 0.5 mm thick fused silica window and it is placed at a distance of 5 mm (water-air setup) or in direct contact with water (water setup). Various diaphragms can be used in order to reduce the light yield. The DOM used is a standard AMANDA PMT enclosed in a Benthos sphere. With this setup a direct comparison of the case WLS foil working in air and WLS foil working in water can be done.

As preliminary results we report here the enhancement obtained in the water-air setup of 23.6% and the one obtained in the water setup of 15.1 %. From the comparison of this two values we extract a TIR component of 36%.

In the apparatus placed at DESY-Zeuthen (see Fig. 2b), water is used in order to generate Cherenkov light from atmospheric muons. The water is held in a steel pot. Two plastic scintillators are placed next to the pot; they are used to determine when a sideways-going muon crosses the water. A trigger system is produced in order to tag the muons and the Cherenkov light production. A test DOM partly immersed in water is used as detector medium. The apparatus runs with distilled water since normal water has not enough transmittance in the UV region where the THV-WLS works. A gain of the order of 16.5% has been measured by this setup.

Improvement in the measurements can be obtained with the use of an aluminum pot since steel has a low reflectivity to UV light and can acts as a UV filter reducing the apparent efficiency of the foil. Moreover, a better modeling of the trigger is conceivable which will include particle showers.

4. Discussion

Optical modules similar to the one used from the neutrino telescope IceCube have been equipped with a novel wavelength shifter foil named THV-WLS. The improvement in light collection efficiency obtained from the use of such material has been estimated to be 15-16% when the foil is immersed in distilled water and 23-24% when the foil is in air. The better performances of the foil working in air are due to total internally reflected

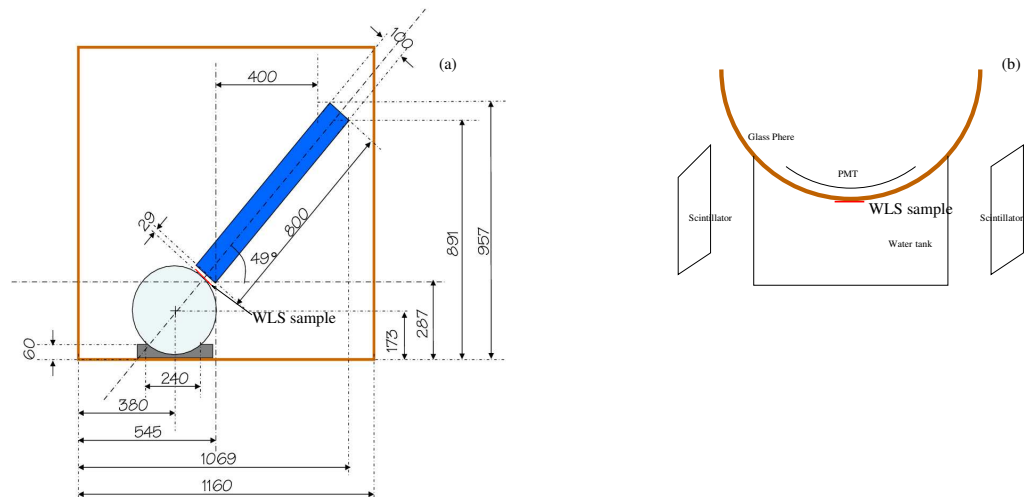

Figure 2. Experimental setups for the measurement of the overall improvement in light collection efficiency. (a) Setup placed at ULB in Brussels. (b) Setup placed at DESY-Zeuthen.

photons. This contribution has been investigated with dedicated measurements. It has been quantified to be in the range 20-40% of the signal obtained when the foil is in air.

In conclusion, given the substantial effect measured in air and in water, THV-WLS has the potential to make a significant contribution to the efficiency of the IceCube detector. We believe the performances of THV-WLS can be further improved. Tests with passive layers with refractive indexes optimized for the collection of the total internal reflected photons and tests with different WLS-dyes are conceivable.

5. Acknowledgments

We thank Dr. H.C. Langowski from the Fraunhofer-Institute Process Engineering and Packaging in Freising (Germany). E.R. acknowledges the support of the Marie-Curie fellowship program of the European Commission.

References

- [1] P.B. Price, L. Bergström, *Applied Optics*, 36, 4181-4180 (1997)
- [2] B.Lubsandorzhiev, L.Kuzmichev, C.Spiering, *Instrum.Exp.Tech.*45 (2002) 742
P. Bauleo, A. Goobar, J. Rodriguez Martino, *NIM A*443(2000) 136-147
- [3] "Wavelength shifter, method for its production and photomultiplier incorporating a wavelength shifter", DESY, patent applied March 24, 2005. Inventor: E. Resconi. No.PCT/EP2005/003200
- [4] E. Resconi, S. Schönert, manuscript prepared for submission to NIM