

PARAMETRIC VARIATION IN CLITIC CONSTRUCTIONS

by

HAGIT BORER

B.A., University of Tel-Aviv

SUBMITTED IN PARTIAL FULFILLMENT
OF THE REQUIREMENTS FOR THE
DEGREE OF

DOCTOR OF PHILOSOPHY

at the

MASSACHUSETTS INSTITUTE OF TECHNOLOGY

June 1981

© Hagit Borer 1981

The author hereby grants to M.I.T. permission to reproduce and
to distribute copies of this thesis document in whole or in part.

Signature of Author _____

Department of Linguistics and Philosophy
June 8, 1981

Certified by _____

Thesis Supervisor

Accepted by _____

Chairman, Departmental Committee

HUM.

MASSACHUSETTS INSTITUTE
OF TECHNOLOGY

NOV 30 1981

LIBRARIES

PARAMETRIC VARIATION IN CLITIC CONSTRUCTIONS

by

HAGIT BORER

Submitted to the Department of Linguistics and Philosophy
on June 8, 1981 in partial fulfillment of the
requirements for the Degree of Doctor of Philosophy

ABSTRACT

The purpose of this study is to account for a range of variations in clitic constructions in various languages, while assuming a restricted class of parameters and a unified theory of clitics.

Specifically, we assume that clitic phenomena in French, Spanish, River Plate Spanish, Rumanian and Modern Hebrew can be given a unified account on the assumption that clitics in these languages are the output of a local rule of morphology, which inserts gender, number and person features into the feature matrix of a head of a lexical category, when that head contains Case assignment features. These features are then combined with the Case feature, and they are given a phonological representation as a complex. This complex of features, the clitic, governs the complements of the head, but cannot itself be that complement. The complement of the head, on the other hand, is coindexed with the clitic. This coindexing, we argue, is a direct result of the process of thematic role assignment, which rules ungrammatical any configuration in which the clitic is not coindexed with the complement position.

Although in languages such as French the complement is never phonologically realized when the clitic is present, in other languages (River Plate Spanish, Rumanian, Modern Hebrew), clitic doubling is attested. In these languages, the coindexing between the clitic and the complement NP is actually attested. In this study, we provide a systematic account of clitic doubling, as well as explain the various ways in which it appears in the above-mentioned languages.

We suggest that parametric variation in clitic constructions can be explained by assuming a particular class of parameters: parameters which involve morphological properties as they are specified

by local rules of insertion and movement. We show that by using this restricted class of parameters we can account for such phenomena as clitic doubling and clitic climbing. We can further account for the difference in extraction possibilities in Rumanian, River Plate Spanish and Modern Hebrew by utilizing the properties of local rules. We also show that the account for pro-drop phenomena and for the pro-drop parameter sketched in Chomsky (1981) is compatible with our proposal, and that the pro-drop phenomenon interacts in an interesting way with our conclusions on the nature of clitics.

The various theoretical claims in this study are substantiated by analyses of genitive constructions and free relatives in Modern Hebrew, clitic doubling in Rumanian, "two-storey" constructions in River Plate Spanish and French, pro-drop phenomena in Modern Hebrew and existential sentences in Modern Hebrew.

Thesis Supervisor: Noam Chomsky

Title: Institute Professor

ACKNOWLEDGEMENTS

There is no doubt that writing a thesis in linguistics at MIT is best captured as the peak point of a rather dazzling educational experience. The people who contributed to this educational experience as well as those who were a constant source of help during the research and the preparation of the document are numerous. As every student learns virtually right away, the only real requirement is "interact" and it is this interaction which contributed most of all to my transformation into a linguist.

First and foremost, I would like to thank my thesis advisor Noam Chomsky. Many of the leading ideas adopted in this study, as well as some particular modes of execution are due to him. His influence is evident throughout the following chapters. Ken Hale and Morris Halle, the other members of my committee, have offered theoretical criticisms as well as methodological comments. During my life at MIT I have benefited significantly from having worked with them. Being Ken Hale's teaching assistant sharpened my perception of language variation. Being Morris Halle's student, on the other hand, has been an invaluable lesson in do's and don't's in linguistics. I thank them both.

Of my other teachers at MIT I would particularly like to thank Joan Bresnan. She greatly influenced my first two years at MIT, and it is to her that I owe my love for syntax and my ability to construct a syntactic argument. I would also like to thank my other teachers at MIT: Jay Keyser for coming through at the right time and Paul Kiparsky, Jim Harris and Haj Ross, who all contributed to my linguistic development.

Thanks go also to Jim Higginbotham for his friendship and for

inspiring discussions.

My fellow students, as well as the visitors to the MIT community, are those who contributed the most to the place as it will stay in my mind. I thank for their support, for their friendship and for their linguistic comradeship Tim Stowell, Anne Rochette, David Pesetsky, Eric Wehrli, Robert May, Ken Safir, Donca Steriade, Barry Schein, Neil Elliott, Adrianna Belletti, Luigi Rizzi, Youssef Aoun, Dominique Sportiche, Luigi Burzio, Alec Marantz, Henk van Riemsdijk, Pino Longobardi, Riny Huybregts, Doug Pulleyblank, Mario Montalbetti, Lisa Travis, Osvaldo Jaeggli and Ann Farmer. I thank also Joe Emonds for extremely useful discussions.

The first year students of Fall 1977, and in particular Ken Safir and David Pesetsky, deserve gratitude for the kindness they offered to the frightened special student that I was at the time.

While researching the Romance languages I have learned a lot from Donca Steriade, Mario Montalbetti, Maria Luisa Zubizarreta and Eric Wehrli. Thank you for your help.

The preparation of the manuscript was a group effort that would not have been accomplished without the help of David Pesetsky, Isabelle Haik, Ken Safir, Eric Wehrli and Anne Rochette. Thank you, David and Isabelle for the wonderful typing job, thank you David and Ken for editing the manuscript and thank you Eric and Anne for the proofreading. And thank all of you for very helpful comments on the manuscript.

Very special thanks go to Elan Dresher, who asked me, eighteen months ago, what I am going to say about sentences such as "dirato ^vsel ha-more". Well, Elan, I hope you will find the answer somewhere between

pages 5 and 200.

On the other side of the Atlantic, two friends deserve a special mention: Ofra Kamar and Tanya Reinhart. Back in Spring 1977, it was their confidence that I could make it that brought me over here. For this I will be forever grateful.

Throughout the last months of writing and agonizing over the typewriter, Eric Wehrli and Tim Stowell have been constant, daily source of support, of encouragement, of warmth and of recreational diversion. They have proved themselves to be real friends, which I will not cease to appreciate.

Finally, special thanks go to my parents, who rightly sensed when the black sheep was turning gray and who promptly offered their full-hearted support.

TABLE OF CONTENTS

	<u>Page</u>
ABSTRACT	1
ACKNOWLEDGEMENTS	3
CHAPTER 1: A THEORETICAL OUTLINE	9
1. General Theoretical Assumptions	14
2. A Restricted Class of Parameters	30
2.1 A Note on Genitive Case Assignment	42
3. A Unified Theory of Clitics	45
3.1 Case Absorption	50
3.2 The Complement Matching Requirement	52
FOOTNOTES	60
CHAPTER 2: CLITIC GOVERNMENT -- AN ANALYSIS OF CLITIC DOUBLING	69
1. Introduction	69
2. The Construct State and Clitic Government	72
2.1 The Construct State: General Properties	72
2.2 On the Differences between Clitics and Lexical NP's	79
2.3 The <u>sel</u> Phrase and the Position of the Clitic	85
2.4 Coindexing and Government	90
2.5 Three Genitive Constructions in Modern Hebrew	102
3. Extraction from Construct State Configurations	106
3.1 Introduction: Predictions	106
3.2 Free Relatives in Modern Hebrew	112
3.3 <u>sel</u> Insertion Revisited	120
4. Proper Government by Coindexed Clitic	123
4.1 Predictions	123
4.2 Two Clitic Configurations	124

	<u>Page</u>
APPENDIX TO CHAPTER 2: Case-Marked Traces, θ -Role Assignment and the Visibility Hypothesis	137
1. Variables as Case-Marked Traces	137
2. The Visibility Hypothesis and A-Chains	145
3. On Assigning θ -Role to Doubled Categories	154
4. Some Theoretical Speculations	160
5. Case-Assignment in Existential Sentences	163
FOOTNOTES	167
 CHAPTER 3: PARAMETRIC VARIATIONS IN CLITIC CONFIGURATIONS	 187
1. Introduction	187
2. Clitic Doubling in Romance	190
3. Extraction from Clitic-Doubling Configurations in Rumanian and the Insertion of Case markers	194
3.1 Extraction	194
3.2 Differences in Extraction between Hebrew and Rumanian: <u>v_sel</u> vs. <u>pe</u>	200
3.3 On the Insertion of Case Markers	206
3.3.1 <u>v_sel</u> Insertion at S-structure	210
3.3.2 Free application of <u>pe</u> Insertion	216
3.4 Nominal Pied-Piping in Rumanian	222
4. Clitics in River Plate Spanish	227
4.1 Clitic-Government and "Two Storey" constructions	229
4.1.1 A Note on Clitic Climbing	250
4.1.2 <u>Permitir</u> -Type Verbs	255
4.2 On Extraction from Clitic-Doubling Con- figurations in RP Spanish: a Unified Account of <u>a</u>	258
4.3 A Note on Dative Clitics	265
4.3.1 Inalienable Possession Constructions	273
APPENDIX TO CHAPTER 3: A Note on French Causatives	279
FOOTNOTES	284

	<u>Page</u>
CHAPTER 4: ON THE INTERACTION OF CLITICS AND PRO-DROP	304
1. Presentation of the Problem	304
2. Pro-Drop in Modern Hebrew	309
3. Existential Sentences -- Analysis	322
4. Existential Sentences -- the Accusative Derivation	331
FOOTNOTES	341
 CONCLUSION	 353
 REFERENCES	 357
 BIOGRAPHICAL NOTE	 363

CHAPTER 1: A THEORETICAL OUTLINE

In recent years, the focus of linguistic research has shifted from the study of systems of rules to the study of systems of principles which govern the application of grammatical processes.

It has always been the assumption of generative linguistics that the purpose of linguistic theory is to understand the nature of the language faculty and to explain the acquisition of language, taking into consideration the impoverishment of the stimuli to which the language learner is exposed and the unavailability of direct negative evidence. The lack of evidence for "language learning" in the common sense of the term "learning", as well as the absence of any plausible learnability theory capable of explaining the nature of language acquisition on the basis of exposure to data alone, has led to the assumption that the language faculty is best characterized as a biological faculty, a mental organ of some sort, with inherent properties of its own. This mental organ has often been referred to as Universal Grammar (UG). UG narrowly restricts the class of possible grammars which the child can infer on the basis of limited, defective data. Informally speaking, then, the notion of UG allows us to suppose that the child, when exposed to linguistic data, does not construct models that would account for the data from scratch, but rather fits them into already existing, innate slots.

Clearly, if one is to allow for the great level of generality which such an approach implies, and at the same time account in a natural way for language variation, the UG component must offer a

rather abstract class of operations and principles. These can then be interpreted in somewhat different ways in different grammars.

Within the theoretical framework of the Extended Standard Theory (as sketched in particular in Chomsky, 1973, 1975, 1976; Chomsky and Lasnik, 1977; and subsequent literature), an example of a general operation that is, in turn, restricted by particular grammars is the rule "Move α ". While the rule itself is part of universal grammar, different grammars may choose different values for α . Further, they can choose to restrict the domain of application of the rule. For instance, it has been argued that in Chinese, "Move WH" applies in the logical form (LF) component, but not in the syntax (see Huang, 1980, for discussion).

UG is composed of two major components. One of these components contains those principles and operations which hold universally, such as "Move α ", \bar{X} theory, the binding conditions, etc. (See section 1 below for some discussion of these notions.) The other component of UG determines the principled ways in which languages may differ from each other with respect to the application of the principles of UG; this is a theory of parameters.

As an example to illustrate our point, let us look at the phrase-structure component, as given in UG by the \bar{X} theory. Clearly, we must allow for parameters of \bar{X} theory that would rearrange categorial components within the \bar{X} system, to permit SVO languages, SOV languages, VOS languages, etc. One could, however, imagine other ways in which the \bar{X} system might vary from one configurational language to another. Thus, for instance, one could imagine a system in which different

languages would select a different number of bars either for a specific category or for X in general. The question of whether such an option is actually realized or not is an empirical issue: if, indeed, a case can be made for this kind of parameter, then clearly it has to be admitted into the system. The availability of this kind of parameter would then be encoded in the theory of parameters in UG.

In essence, dividing UG into principles, on the one hand, and parameters, on the other, implies a particular process of language acquisition. When a child is exposed to input data, he is equipped with two sorts of mechanisms. First, he has available to him a grammar built on universal principles. Second, on the basis of input data, the child determines the value of a particular parameter. The set of choices and their nature is predetermined: the input data does not introduce a previously non-existent theoretical mechanism or a choice which is not specified in the parameters of UG. Rather, it allows the child to choose a particular possibility from two (or more) existing ones.

Note that although the role of input data in this case is vitally important for choosing the right option, the relationship between the determining evidence and the option chosen does not have to be direct. It suffices that the grammatical analysis of the input data cannot be reconciled with one of the choices. For example, it will be shown below that, on the basis of the absence of a pronoun in subject position in certain languages (the "pro-drop" phenomenon), the child deduces the level at which a local rule applies: the rule of Affix Hopping of Chomsky (1957)!

The universal processes and principles, as fixed and determined by the choice of parameters in UG, constitutes the individual grammar of a particular language, often referred to as core grammar. Thus, given these two components of UG and the input of data, the mental organ in question is not only a predetermined, rigid endowment, but also a language acquisition device (LAD) to which experience serves as input and core grammar as output, as illustrated by the diagram in (1):

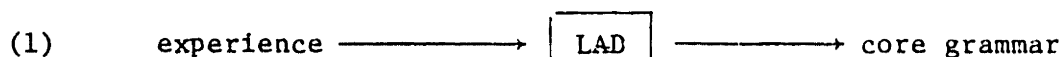

Given the high level of abstractness of the UG component, it is clear that a parameter which determines the choice between several available possibilities in UG may have complex and varying consequences in various domains of the grammar. Thus, on the basis of rather limited evidence, quite different grammatical systems can be constructed. Again, we will return below to further examples of such cases.

Clearly, it is a desirable step forward in the investigation of UG to try to restrict the class of possible parameters. The strongest claim in this respect would be that, in fact, there are no language-particular choices with respect to the realization of universal processes and principles. Rather, grammatical variations can be restricted to the idiosyncratic properties of lexical items. These idiosyncracies, which are clearly learned, will then interact with general principles of UG in a particular way. This particular interaction will then result in vastly different systems. The weakest claim with respect to the nature

of parameters would be the claim that every single principle of UG can be true or untrue for a particular grammar, depending on the availability of input evidence that can determine it.

While the latter position considerably weakens the notion of UG (note that it predicts that there can be two languages which do not share any principles of UG), the former is quite hard to maintain. Furthermore, this strong claim is clearly false. First, it offers no way to capture the distinction between configurational and non-configurational languages. Second, it is quite clear that the ordering of components within the \bar{X} system, as mentioned above, is independent of the properties of lexical items. Rather, it is clearly an option available in UG.

Since so few languages have been investigated in detail with suggested principles of UG in mind, it is still premature to offer a comprehensive theory of parameters. Nevertheless, it is clearly desirable to try to reduce as many language-particular phenomena as possible to the learned properties of lexical items. This study is an attempt to do this. We will suggest a unified explanation of some clitic phenomena, as they appear in Modern Hebrew and in some Romance languages (Standard Spanish, River Plate Spanish, Rumanian, French). It will be shown that, given a restricted class of parameters, many variations among languages with respect to the occurrence of clitics can be explained. These parameters will all involve local rules which specify in their environment either particular grammatical formatives or a feature of inflectional morphology.

The organization of this study will be as follows: in the remainder of chapter 1 we will sketch the general theoretical framework which we

assume in this work. Essentially, it is the framework of Government-Binding (GB) as outlined in particular in works such as Chomsky (the Pisa Lectures), Chomsky (1981), Kayne (1981) and others. In section 2 below we will define a restricted class of parameters, showing that certain domains of language-particular phenomena can be characterized given the properties of local rules. In section 3 below we will sketch the general theory of clitics which we shall argue for in detail in this study.

In chapter 2, the theory of clitics which is sketched in section 3 of this chapter will be argued for in detail and will be motivated on the basis of data from genitive constructions in Modern Hebrew. In chapter 3, it will be suggested that the analysis of clitics motivated in chapter 2 is subject to parametric variation. It will be shown that, given the restricted class of parameters suggested in section 2 of chapter 1, all these variations can be accounted for. In chapter 4 the analysis of clitics suggested in this study will be shown to interact in an interesting way with another parameter of core grammar: the pro-drop parameter as discussed in Chomsky (1981). The interaction of the pro-drop parameter with the properties of clitics will supply additional evidence both for the class of parameters which we argue for and for our analysis of clitics. The evidence in chapter 4 will be from existential sentences in Modern Hebrew.

1. General Theoretical Assumptions

The general framework assumed in this study is that of Government-Binding (GB), as sketched mainly in Chomsky (the Pisa Lectures), Chomsky (1981) and subsequent work.¹

The central concern of GB is to characterize the positions in which

different manifestations of NP's can appear. These manifestations include fully realized referential expressions, lexical anaphors and the empty elements: PRO, [_{NP}^e] (NP trace) and variables (WH traces, traces of quantifier raising etc.). To this end, GB assumes several subsystems, each predicting a certain distribution of nominal elements in a certain domain: the theory of the lexicon (which contains complementation specifications and thematic specifications), Case theory, the binding theory and control theory. These systems interact with each other in several ways and this interaction is further constrained by certain well-formedness conditions on derivations.

The GB framework shares with an earlier version of the Extended Standard Theory its perception of the structure of core grammar. This structure, following Chomsky and Lasnik (1977), is given in 2:²

(2)

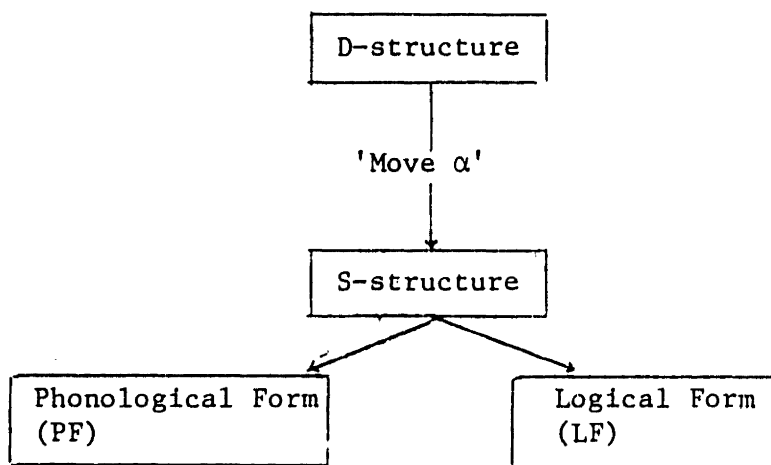

The essential claim of a grammatical model such as (2) is that representations at S-structure feed into two separate components. These components do not interact with each other. Thus, an operation in the LF component cannot trigger the application of a phonological rule, nor can an operation

in PF affect rules in LF.

The D-structure component of (2) can be factored into the lexicon and the phrase structure component. The latter we will take to be some version of the \bar{X} system (for discussion of this system see Chomsky, 1970; Bresnan, 1976 ; Emonds, 1976 ; Jackendoff, 1977; Stowell, 1981; and others). Following ideas of Hale (1978) further developed in Chomsky (1980), we will take the inflection node (INFL) to be the head of \bar{S} and S. INFL is itself composed of a TENSE component and an agreement component (AGR). Thus the basic phrase structure rules of English are as in (3):

$$(3) \quad \overline{\text{INFL}} \longrightarrow \text{COMP} \quad \overline{\text{INFL}}$$

$$\overline{\text{INFL}} \longrightarrow \text{NP} \quad \text{INFL} \quad \text{VP}$$

In chapter 4 of this study the AGR component of INFL will be discussed extensively. We will have little to say about the TENSE part of INFL.

D-structure is best characterized as that component in which one-to-one correlations hold between referential expressions and thematic roles, between subcategorization frames and the categories which fulfill them. This assumption is rather natural; at that level of the derivation or prior to it, no operations that link two positions on a tree have applied. Thus the satisfaction of thematic requirements and subcategorization frames has to be "local". We will return to the precise nature of this "locality" below.

The linking of positions in the tree is a property of the transformational component and of S-structure.

In the transformational component, the rule "Move α " maps D-structure representations onto S-structure representations. Thus it could be considered simply a mode of linking positions on the tree. S-structure is now to be regarded as the level in which positions are linked. If so, it is natural to assume that at this level lexical specifications like subcategorization requirements and thematic assignment are met by linked elements, rather than by single, non-linked elements. In this sense, the requirements are not met "locally".

Let us try and make this description more precise. Subcategorization frames are specified in the lexical entry of each item. Similarly, every lexical category which can assign a thematic role is specified in the lexicon as assigning this particular thematic role in a particular position, a thematic position. The one-to-one correlation between the assignment of a thematic role and the referential expressions which fill these positions is captured by the θ -criterion (θ =thematic), informally stated as in (4):

(4) The θ -criterion

- i. Each θ -position is assigned an argument
- ii. Each argument is assigned a θ -role
- iii. Only arguments are assigned to θ -positions

(For some discussion of the θ -criterion and its properties see Freidin, 1978, who argues for a similar principle; Borer, 1980a and Chomsky, 1981). The argument specified in the definition in (4) we will take to be a lexical NP (either a name or a lexical anaphor), the pronominal elements (including the pronominal anaphor PRO) and variables. Crucially this list does

not include NP traces.³

The principle in (4) ensures that every θ -position will be filled by only one argument, and that every argument will be assigned only one θ -role. The notion "assigned to" in (4) is interpreted according to the Projection Principle of Chomsky (1981), stated informally as in (5):

(5) Lexical requirements must be met at every level.

Lexical requirements in the sense of (5) include subcategorization frames and θ -role assignment. Now recall that, whereas in D-structure no linking mechanisms were available, in S-structure such links are established either by "Move α " or by the binding conditions (to which we will return below). It naturally follows that at D-structure there must be a one-to-one correlation between lexical requirements and single, unlinked elements. In the absence of linking mechanisms, (5) can only be met if all lexical requirements are met: i.e. if all θ -positions are filled, all subcategorization frames are satisfied, etc. The Projection Principle thus gives content to the "locality" of representations in D-structure.

At S-structure, on the other hand, a network of links has been established. It is these links which satisfy lexical requirements, if there is an element in the link, whether a fully realized NP or its trace, which is in a position in which these requirements have to be met.

The links established at S-structure, to which lexical requirements apply, are called chains. In order to exemplify the interaction of the notion chain with the Projection Principle of (5), consider the following sentences:

- (6)a. John hit Mary
- b. [_{NP}^e] was hit Mary (by John)
- c. Mary_i was hit [e]_i (by John)

The verb hit in (6)a subcategorizes for an NP complement to which it assigns a θ -role in the post-verbal position. (This θ -role is presumably that of a patient. For some discussion of the nature of θ -roles, see Jackendoff, 1972.) In (6)b, when the verb hit appears in its participial form, there is no reason to assume that its subcategorization frame and θ -assignment properties have changed. In fact, the correlation between (6)a and (6)b is captured if we assume that they have not changed. (6)b is the assumed D-structure representation of (6)c. In this D-structure, subcategorization requirements and θ -role assignment apply to the post-participial NP Mary. Thus, the Projection Principle is met at D-structure.

To (6)b the rule of "Move α " applies, yielding the S-structure representation in (6)c. Now we have a chain which consists of the preposed NP Mary_i and its coindexed trace. This chain now satisfies (5), although the position following hit in (6)c is not filled by an argument, but by a trace of an argument. Since this trace is part of the chain which contains an argument -- the subject Mary -- the chain can fulfil the lexical requirements of hit. In essence, then, given the "local" nature of D-structure and the non-local nature of S-structure, involving chains, "Move α " is now an operation mapping D-structure representations onto S-structure representations in accordance with the Projection Principle, combined with the θ -criterion and subcategorization requirements. Given this system, the representation in D-structure or at S-structure of (6)c

as (7) is blocked:

(7) *Mary was hit (by John)

In (7), the lexical requirements of hit are not met either at D-structure or at S-structure.

The formation of chains at S-structure is in accordance with the binding conditions, to which we will return below (and see appendix to chapter 2 for a precise definition of the notion "chain" and for some discussion of the consequences of this notion for other subsystems of the model). The notion of "chain" as defined in Chomsky (1981) is intended to apply both to A-chains (A = argument), in which all the elements in the chain are in an A-position, and to \bar{A} -chains (\bar{A} = non-argument), in which one of the positions in the chain is not an A-position, for instance, COMP. (A-position here means a position in which an argument may appear at D-structure.) Although it will be obvious below that the notion of bound as defined in (12) is intended to cover both the relationship between two A-positions and the relationship between an A-position and an antecedent in an \bar{A} -position, we will not be concerned with \bar{A} -chains in this study. For some discussion of these chains see Chomsky (1981), Aoun (forthcoming).

Thus far, we have mentioned the predictions about the distribution of NP's which are made by θ -theory (the θ -criterion), \bar{X} theory and the theory of subcategorization frames. These different systems interact to predict the distribution of arguments at D-structure, but not the distribution of non-arguments at D-structure. With Chomsky (1981), we will assume that, in fact, non-arguments are not represented at D-structure.

Rather, they are inserted at S-structure in non- θ -positions. These non-arguments include pleonastic elements such as it and there in English or expletive PRO's in languages which have such PRO's (so-called "pro-drop" languages; see chapter 4 below for extensive discussion).

The distribution of NP's at S-structure is already partially predicted by the θ -criterion combined with the Projection Principle. Since all θ -positions have to be filled at D-structure, and since the movement of an argument so as to cover the trace of another moved argument will result in a violation of the Projection Principle, it follows that movement is only possible from a θ -position to a non- θ -position. Other principles which determine the distribution of NP's at S-structure are the binding conditions, the theory of control and Case theory.

Let us first consider the binding theory. Crucially, the binding theory utilizes the notion of government. This notion plays a central role in determining the properties of many subsystems in the GB framework. Notably, complementation requirements are met in the domain of government (where by complementation requirements we mean, again, subcategorization frames and θ -role assignment).

Case assignment is sensitive to government, as is the application of the binding conditions. In this study, we will presuppose the definition of government given in (8):⁴

(8) Government (definition)

In the configuration [... β ... α ... β ...] α can be said to govern β iff:

- i. $\alpha = X^0$
- ii. where ϕ is a maximal projection, if ϕ dominates β then ϕ dominates α
- iii. α c-commands β

The definition of c-command which we assume is as in (9):

(9) C-command (definition)

α c-commands β iff:

i. α does not contain β

ii. Suppose that $\gamma_1, \dots, \gamma_n$ is a sequence such that:

a. $\gamma_n = \alpha$

b. $\gamma_i = \alpha^j$

c. γ_i immediately dominates γ_{i+1}

then if δ immediately dominates α then either:

I. δ dominates β ; or

II. $\delta = \alpha_1$ and α_1 dominates β

The definition of government in (8), coupled with the definition of c-command in (9), essentially entails that within a maximal projection, the head governs everything. Further, given the definition of c-command in (9), the head governs elements which are adjoined to its category. Thus, in a configuration such as (10), X governs all the NP's in the structure:

(10)

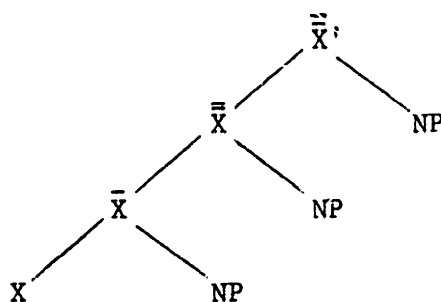

$\bar{\bar{X}}$ = adjoined maximal projection of X.

Throughout this study, we will make extensive use of the definition of government in (8), based on the definition of c-commands in (9). We will, however, suggest a slight reformulation of (9) that will restrict the sequence $\gamma_1, \dots, \gamma_n$ in (ii) to elements which share the same head (see

chapter 2, definition in (42) and related discussion). We will also make extensive use of the fact that, under the \bar{X} system, heads have to govern their complements. While in simplex sentences this requirement is trivially met, in more complex configurations, such as the construct state in Modern Hebrew and causative constructions in Romance, this requirement will be shown to interact in an interesting way with constraints on coindexing and on reanalysis (see section 3 of this chapter for some more discussion).

The notion of government also plays a crucial role in the theory of binding. The theory of binding seeks to characterize and further restrict the distribution of nominal elements at S-structure. This theory will specify the correct linking of moved constituents and their traces (whether moved WH elements or moved NP elements). It will further specify the correct linking of an antecedent and a lexical anaphor. Given the notion of chain described above and given the fact that chains are seen as satisfying lexical requirements, it is clear that the binding theory plays a crucial role in determining the correct linking relationships creating a chain.

Thus, as we have seen, the Projection Principle coupled with lexical requirements predicts the distribution of NP elements in the base, while the Projection Principle coupled with the binding conditions determines the distribution of NP elements at S-structure. The binding conditions are given in (11):

- (11) A. an anaphor is bound in its governing category
(anaphors: NP traces, lexical anaphors, PRO)
- B. a pronominal is free in its governing category
(pronominals: pronouns, PRO)
- C. an R(=referential) expression is free
(R-expressions: names, variables)

The definition of the notion bound is given in (12) and the definition of a governing category in (13):

(12) α is X-bound by β iff α and β are coindexed, β c-commands α and β is in an X-position.

$X = A, \bar{A}$

(13) β is a governing category for α iff β is the minimal category containing α , a governor of α and a SUBJECT accessible to α .⁵

The binding conditions as stated in (11) subsume the Tensed S condition and the Specified Subject condition of Chomsky (1973) (later formulated as the Propositional Island condition (Chomsky, 1976) and the Opacity condition (Chomsky, 1980) respectively), although the predictions made by these earlier systems do not completely overlap with the predictions made by the binding conditions. (For discussion see references cited above.)

The binding conditions in (11) make an interesting prediction with respect to the pronominal anaphor PRO. PRO falls both under the binding condition A and under the binding condition B. Thus, if it has a governing category, it must be free according to the latter but bound according to the former. It follows that PRO cannot have a governing category or in other words, PRO cannot be governed. The only position in which PRO can appear, then, is an ungoverned position. Assuming that the set of governors are N,P,V,A and AGR the only position in which PRO can appear is the subject of infinitive position. This position is not governed, since the value of AGR in infinitival clauses is [-].

Given the properties of various elements, such as R-expressions,

lexical anaphors, NP traces and variables, the binding conditions will predict the distribution of these elements at S-structure. The binding conditions will also determine which chains (in the sense of chain discussed above) are well-formed chains which can, in turn, satisfy lexical requirements in accordance with the Projection Principle in (5) above.

We now turn to yet another subsystem which predicts the distribution of NP elements. This system is Case theory. It has been proposed in Rouveret and Vergnaud (1980) that the following filter holds in core grammar:

- (14) *NP when NP has a phonetic matrix
[-Case]

Case assignment is sensitive to government. Thus accusative Case is assigned when an NP is governed by a verb (and adjacent to it; for some discussion of accusative Case assignment see section 2 below. For extensive discussion of the adjacency condition on Case assignment see Stowell, 1981). Oblique Case is assigned when the NP in question is governed by a preposition or a preposition-like element (again, adjacency has to be met), and nominative Case is assigned when the NP in question is governed by AGR (see chapter 4 for extensive discussion). Given that the notion of government is crucial both for the binding theory and for Case theory, it is not surprising that the position which is not "covered" by the binding conditions is also "left alone" by Case theory: the subject position of an infinitival. Thus this position is not Case marked and does not enter the binding conditions for the same reason in each case: it is not governed.

The subject position of infinitivals also supplies us with a case in which the binding conditions will fail to rule a sentence out, but Case theory will. Thus the sentences in (15) are ungrammatical,

although from the point of view of the binding conditions they are well-formed:

(15)a. *John tried Bill to win

b. *John decided Bill₁ to be believed [e]₁

Bill in both (15)a and (15)b satisfies lexical requirements. In (15)a it is itself in a θ -position and in (15)b it is part of a chain which has a member in a θ -position ([e]₁). Thus, (15)a-b cannot be ruled out as a violation of the Projection Principle or the θ -criterion. Furthermore, in (15)b, where the binding conditions are relevant, [e]₁, being an NP trace, thus an anaphor, is bound in its governing category by Bill₁. Nevertheless (15)a-b are ruled out, since Bill cannot receive Case in the subject position of the infinitive and hence it violates the Case filter in (14) above.

Following proposals of Aoun (1979b), we will assume that the Case filter is located in the phonological component of the grammar. This assumption is consistent with the proposal of Chomsky and Lasnik (1977), who locate the filter component in PF, following deletions. Locating the Case filter in the phonological component enables this filter to interact with morphological rules of Case assignment which apply in the phonological component.

Let us now turn to the LF component in the model in (2), (throughout this work I will use the terms "LF component" and "interpretive component" interchangeably, referring to the right side of the split model in (2) above). Recall that (5) requires that lexical specifications be met at

every level. Thus, these specifications have to be met in the LF component as well. However, at this level, again, these requirements are met by chains formed at S-structure. Chomsky (1981) argues that there is a well-formedness condition on chains in LF. This well-formedness condition requires that the chain be Case-marked in order to be assigned a θ -role in the LF component. This condition, henceforth the Visibility Hypothesis, will be discussed in detail in the appendix to chapter 2.

The LF component contains rules of quantifier raising (QR in the sense of May, 1977), rules which prepose into COMP WH elements which are in situ at S-structure, and rules which assign interpretation to focus configurations. It further contains the theory of control, which will not be touched upon in this study.

Crucially, the grammar contains the following principle:

(16) The Empty Category Principle

an empty category must be properly governed

(17) Proper Government (definition)

α properly governs β iff α governs β and:

- i. α is +N, +V, or
- ii. α is coindexed with β

The ECP has been utilized to explain various phenomena, previously attributed to other factors. Thus it has been utilized to explain the "that t" filter of Chomsky and Lasnik (1977) (see in this respect Kayne, 1980a; Pesetsky, 1978, and Taraldsen, 1978), although these accounts utilize those aspects

of the earlier Nominative Island Condition (Chomsky, 1980) which were later subsumed by ECP. It has been further involved to explain the phenomenon of preposition stranding (Kayne, 1980b), of quantifier raising in certain configurations (Kayne, 1981; Rizzi, 1980; Jaeggli, 1980 and others) and other phenomena.

In this study, we will argue that the proper formulation of condition (i) in (17) is as in (17'):

(17') i. α is +V

The argument will be based on extraction facts from Modern Hebrew.

Kayne (1981) has shown that the condition in (16) applies to empty categories which are left by movement rules in LF. Notably, it applies to variables which are left by the rule of quantifier raising. Thus there is reason to assume that the ECP holds in LF. We will assume that this is indeed so. The discussion in chapter 2 will supply additional strong evidence for this assumption (and also see Jaeggli, 1980 for an argument that ECP holds in LF in Spanish, Rizzi, 1980 for an argument that it holds in LF in Italian, and Aoun, 1981 for an argument that it holds in LF in Standard Arabic and Lebanese Arabic).

Let us now summarize. The model of core grammar given in (2) above contains different subsystems which are located in different modules of its structure. The different components of this model interact to determine the distribution of nominal elements at D-structure, at S-structure and in LF. At D-structure, these systems are θ -theory, \bar{X} -theory and the theory of subcategorization frames. The distribution of NP's which follows

from these systems is subject to the Projection Principle, the well-formedness condition in (5) above.

Following the mapping from D-structure to S-structure by "Move α " and the establishment of linking relationships in S-structure by "Move α " and the binding conditions, the Projection Principle along with the binding conditions determine the distribution of nominal elements and ensure the correct formation of chains. These chains, in turn, satisfy lexical specifications, in accordance with (5). The representation in S-structure then serves as an input to two separate systems. One is the PF component, in which the appropriateness of the distribution of NP's which do not have a phonological matrix is checked by the ECP and by the theory of control. In (18) we repeat the model in (2), indicating for each component the subsystems which are part of it:

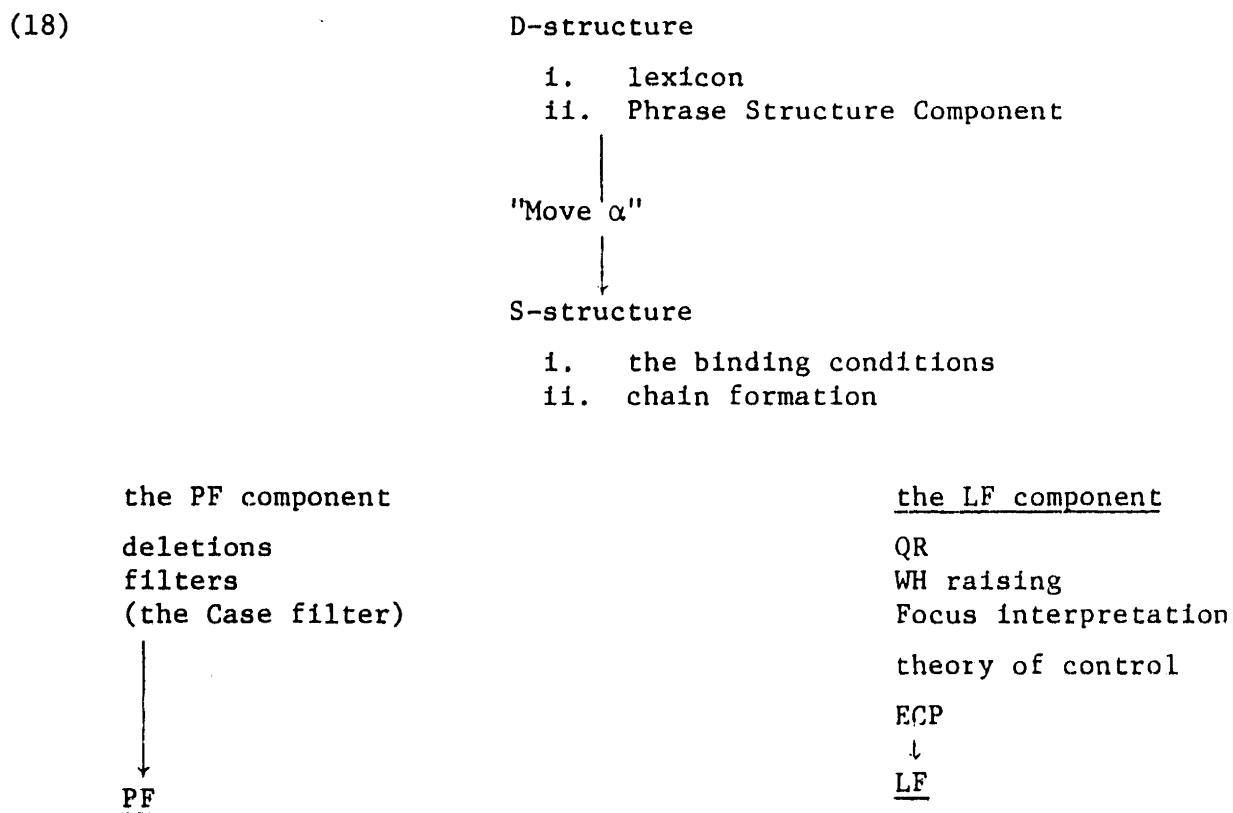

(in the listing of systems in D-structure and S-structure no ordering is implied).

Conditions on well-formedness:

1. The Projection Principle
2. The θ -criterion (4 above)
3. The Visibility Hypothesis

This summary of GB is not intended as a comprehensive introduction. Rather, it is intended to provide a short overview of the theoretical considerations which guide the investigation in the following chapters. Various subsystems and notions will be treated in greater detail, in particular, government, the Case filter, ECP, the notion of chain and the Visibility Hypothesis. As we discuss these subsystems and notions, their definitions will be repeated and they will be discussed in greater detail. For a more comprehensive description of the GB framework the reader is referred to the references cited throughout this section.

2. A Restricted Class of Parameters

Clearly, it is still premature to offer at this stage a general theory of possible parametric variation. However, as noted above, it is desirable to reduce as much variation among languages as possible to the idiosyncratic properties of lexical items, indicating how these idiosyncratic properties interact with general principles of UG. It was noted that this class of variations does not include any options with respect to the application of universal processes. Rather, it involves the way in which universal processes will interact with a particular, specific set of properties, which is clearly learned.

Let us give an example of what we have in mind. Suppose that UG

allows for the insertion of dummy Case markers in front of nominal elements. Further suppose that Case features cannot be assigned to non-phonetically realized NP's. Note, however, that the specific environment in which the insertion of dummy Case markers is possible is determined by the idiosyncratic, learned properties of a particular dummy Case marker. Now suppose there is a language L whose grammar G contains the dummy Case marker D. D in G can be inserted in the environment A__NP, where A itself is not a Case assigner. Now suppose there is a language L' whose grammar G' differs from G minimally in that it does not contain the marker D. Given the Case filter, we then expect G to contain the sequence A D NP. G', on the other hand, does not allow for the sequence A D NP, since D does not exist in L'. Furthermore, the sequence A NP cannot appear in L' either, since A is not a Case assigner and hence NP will not have a Case and the sequence A NP will violate the Case filter in (14) above.

Concretely, consider the following sentences from Lebanese Arabic and Hebrew, respectively:

- (19)a. ḥkīt ma9 Karīm
 talked-I with Karim
 'I talked with Karim'
- b. ḥkīt ma9-o
 'I talked with him'
- c. ḥkīt ma9-o_i la-Karīm_i
 talked-I with-him to-Karim
 'I talked with Karim'
- (Aoun, forthcoming)
- d. dibarti 'im Neca
 talked-I with Neta
 'I talked with Neta'

- e. dibarti 'it-a
'I talked with her'
- f. *dibarti 'it-a_i (le-)Neta_i⁷
talked-I with-her to Neta

In the subsequent chapters, we will argue that in cases such as (19)b, (19)c and (19)e the clitic (o in Lebanese Arabic and a in Modern Hebrew) absorbs the Case features of the preposition ma9 and 'im 'with' in these languages (and see also Ajun forthcoming). Given this assumption, the ungrammaticality of (19)f follows from a principle of UG. In (19)f the Case features of the preposition were absorbed by the clitic and the NP Neta cannot receive Case. Thus it violates the Case filter and the sentence is ungrammatical.

Now consider (19)c. In (19)c the Case marker la (roughly 'to') is inserted preceding the object of the preposition, thus assigning Case to it. This Case assignment renders the sentence grammatical, since Karim in (19)c receives Case. Although the Case features of ma9 are absorbed by the clitic, its object can receive Case by the inserted preposition.

The insertion of a Case marker preceding an object of a preposition in Hebrew is impossible. Let us assume that the grammar of Lebanese Arabic contains the rule in (20) but that the grammar of Hebrew does not contain an equivalent rule:

$$(20) \quad \emptyset \longrightarrow \underline{la} / [{}_{pp} \dots \underline{\quad} NP]{}^8$$

(Recall that we are assuming that the universal process of Case assignment specifies that Case features can be assigned only to phonologically realized

NP's. Hence, in (20) we do not have to specify that the NP in question has to be phonologically realized).

The availability of (20) in the grammar of Lebanese Arabic but not in the grammar of Hebrew accounts for a parametric variation between Hebrew and Lebanese Arabic in a straightforward way: in Lebanese Arabic we find the phenomenon known as "clitic doubling" attested in PP's, but in Hebrew this phenomenon is not attested in the same environment.

Clearly, every language has to allow for language particular rules of the type in (20). Note that the rule in (20) has different properties from other rules which have universal status, such as "Move α ". First, the rule in (20) admits conditions on analyzability, in that it is specified in (20) that the NP in question has to be [NP,PP]. Second, the rule in (20) is strictly local, in that it does not contain a variable and in that the elements specified in the rule are adjacent. We would like to claim that the rule in (20) is a local rule in the sense of Emonds (1976).

Following Emonds we will take the definition of a local rule to be as in (21):⁹

- (21) local rule: an operation which affects only a sequence of a single nonphrase node C and one adjacent constituent C' that is specified without a variable, such that the rule is not subject to any condition exterior to C-C' (or C'-C) is called a local rule.

In this study we will explore the possibility of accounting for parametric variations within the clitic system by exploiting the properties of local rules. (In assuming that inter-language variations may be explained by differences in the application of local rules we will be following ideas of

Emonds, 1980.)

Let us clarify what we have in mind. With respect to C' in (21), we will assume that it stands for a term in the \bar{X} notation. C , on the other hand, we will take to be either a specified grammatical formative (such as have, of, tense etc.) or a specified feature of inflectional morphology of a lexical formative (such as Case, gender, number, person etc).

Intuitively speaking, the class of parameters which we are suggesting in this study all involve features of inflectional morphology such as Case, gender, person, tense etc. In assuming this distinct class of features we will be following Chomsky (1965) who claims that,

A formative must be regarded as a pair of sets of features, one member consisting of the "inherent" features of the lexical entry or the sentence position, the other member consisting of the "non-inherent" features introduced by transformation (p. 182).

We will further assume that the "noninherent" features, the features of inflectional morphology, are "selected from a fixed universal vocabulary" (p. 66).

The distinction between grammatical formatives and features of inflectional morphology may seem arbitrary at first, since in most of their occurrences grammatical formatives seem to be phonological matrices or categories which are connected with a set of morphological features of the type discussed here. Thus la in example (19)c above functions as a Case marker; have, in its auxiliary function, functions as a marker of tense and aspect etc. However, we would like to argue that there is a reason

to believe that grammatical formatives differ from features of inflectional morphology in one respect: whereas features of inflectional morphology carry no semantic information, being instantiations of "noninherent" features in the sense mentioned above, we will take grammatical formatives to have separate lexical entries which may include separate sets of "inherent" properties in the sense discussed above. An obvious example of this is the clear difference in meaning between the verb get in (22)a and the verb be in (22)b, although both of them function as auxiliaries and thus as grammatical formatives in (22):

- (22)a. John got fired from his work
 b. John was fired from his work

Clearly, the difference between get and be in (22) cannot be captured in terms of grammatical function. Rather, it depends on the "inherent" features of these verbs.

Nevertheless, we will take the set of inherent properties of grammatical formatives to be defective in certain respects. In particular, we will assume that grammatical formatives never assign a θ -role in the sense discussed in section 1 above and that they are never major categories in the \bar{X} system (where "major categories" are N, A and V). Thus in both (22)a and (22)b the θ -role is assigned to John by the verb to fire, and in (19)c above the θ -role is assigned to Karim by ma9, rather than by la.

Certain PP's seem to be a counterexample to this claim. In these cases, the preposition seems to assign a θ -role to its object although it is nevertheless desirable to characterize it as a grammatical formative.

Such is the preposition to in dative constructions in English, as in (23):

(23) John gave a book to Mary

In chapter 3 section 3.4, we will argue that in (23) prepositions such as to in dative constructions function as prepositions selected by the verb to assign dative to an indirect object. The θ -role, however, is assigned by the verb (presumably, in this case, the role of a goal). Furthermore, in some sense, even the property to assign dative Case (or more appropriately, the requirement of a dative complement) is a property of the verb, and the selection of to as the preposition preceding Mary follows from this property.

The preposition to can however serve as a true preposition and as a true θ -role and Case assigner in its directional meaning, when it is not selected by the verb, such as in (24):

(24) John went to the movies

The application of a local rule is further subject to a government requirement. Thus we will assume that in the definition of local rules in (21), at least one of the terms specified in the rule (C or C') has to govern the other. Thus, for instance, in (20) above, the preposition la can only be inserted into a position which governs the adjacent NP. This condition is clearly necessary in order to block the application of local rules to two elements which are adjacent on a string but which bear no structural relationship to each other. We will argue below that Case assignment rules are an instantiation of local rules. Thus the government requirement on the application of local rules enables us to capture the generalization that Case assignment is determined both by government and

by adjacency.¹⁰

Having described what we mean by the terms C' and C in (21), let us now turn to the operations which local rules can perform. We will assume that local rules can insert elements, move elements and delete elements. In this study, we will restrict our attention to operations which insert the node C or which move the node C (namely, rules which insert or move a grammatical formative, insert a feature of inflectional morphology or change its location). Following Chomsky (1981) we will assume that local rules which move the node C (whether it is a full formative or merely a feature) do not leave a trace. Thus, the output of local movement rules is not subject to the conditions to which the output of "Move α " is subject, such as the binding conditions or ECP.¹¹

Let us now make another assumption. Let us assume that local rules may apply at any level at which they are relevant: at the base, in the syntactic component, at S-structure, at PF and at LF.

A short comment is appropriate here with respect to the application of local rules in the LF component. Note that the application of such rules in LF will not have any phonological representation, given the split model sketched in section 1 above. As such, it is hard to see how any evidence about their existence is ever available to the language learner. Thus it is rather implausible to assume that language-particular rules do take place in that component. Rather, we will proceed under the assumption that they do not. Note, however, that this is entirely an empirical issue. If a case can be made that a certain phenomenon can be explained by assuming that a certain local rule which is language-specific applies

in LF and if some syntactic evidence can be brought to bear on this issue, this option should be admitted into the grammar. At this stage, however, it is hard to see what the evidence might be.

Clearly, the application of a local rule R at a level L is subject to the condition that the environment for the application of that rule is met at L. As an example, consider the assignment of Case. We will assume that most of the rules which assign Case are local rules. These rules are best captured as a transference of a feature from an element which has Case-assignment features to an adjacent NP complement when this complement is governed by these Case features. Such a Case-assigning element can be a verb, a preposition or a dummy Case marker (such as la in rule (20) above). The adjacency requirement for the assignment of Case by verbs, prepositions and dummy Case markers seems to supply strong evidence in favor of regarding these rules as local rules (for discussion of the adjacency condition on Case assignment see Stowell, 1981). An example of an accusative assignment rule is given in (25):¹²

$$(25) \quad [{}_{\text{v}} \dots \text{accusative}] \text{ NP} \longrightarrow \text{V NP} \\ \text{[+accusative]}$$

In accordance with our assumption about the nature of local rules, we would like to argue that (25) can apply at any level of the derivation. Consider now the cases of exceptional Case marking, in which a certain class of verbs can assign accusative Case to the subject of the subordinate clause:¹³

- (26)a. John expects [_S Bill to like Jane]
 b. Who_i does John expect [_S [e]_i to like Jane] ?
 c. John expects [_S Jane_i to be liked [e]_i (by Bill)]

In (26)a, Bill is generated in the subject position. Given the ability of expect to assign accusative Case to the subject of the subordinate infinitival, Bill is marked as accusative by (25) and the sentence is grammatical. Note that since "Move α" does not apply to (26)a, the environment in (25) is met at D-structure, at S-structure and in PF. Hence we will assume that, in (26)a, (25) can in fact apply at any of these levels.

Now consider (26)b. In this case, although the environment of the application of (25) is met at D-structure and at S-structure, accusative Case can be assigned only at D-structure. At S-structure, following the application of "Move α", the environment specified in (25) is only met by an element which is not phonologically realized; hence it cannot be assigned accusative Case. (Recall that we are assuming that NP's which lack phonetic matrices cannot be assigned Case.) Thus, if (25) fails to apply prior to "Move α", the derivation is ruled out.¹⁴

Now consider (26)c. In (26)c, the environment for the application of (25) is not met at D-structure. The structure of (26)c at D-structure is as in (27):

- (27) John expects [_S [e] [_{VP} to be liked Jane]]

At D-structure the subject position of the subordinate clause is null.

Thus, accusative Case cannot be assigned to it. On the other hand, after the application of "Move α " Jane is in the subject position and satisfies the environment for accusative assignment specified in (25). Thus in (26)c, (25) can apply at S-structure and in PF, resulting in a grammatical derivation. Its application at D-structure will result in ungrammaticality. In chapters 3 and 4 we will see that there is reason to believe that in some cases a well-formed derivation results only if the application of a local rule takes place in the phonological component.

Let us then formulate the following universal principle:

(28) Given a local rule R, R may apply at any level.

Yet another property of local rules is that the principle in (28) is subject to language-particular variations. A particular language may choose to restrict the application of R to a certain level. In chapter 4 below we will see that the pro-drop phenomenon can be accounted for if we assume this restriction. In non-pro-drop languages, the rule which attaches the agreement node (AGR) to the verb is restricted and cannot apply in the syntactic component. Let us assume that the restriction on the application of local rules obeys the general formula in (29):¹⁵

(29) R may not apply at level L.

Let us summarize at this point our proposal for restricting the class of possible parameters. We would like to argue that parametric variations in clitic configurations can be accounted for by using a restricted class of parameters. We assume that every language contains

local rules, whose formula is given in UG and which are defined in (21) above. We will further assume that the class of local rules as given in UG has two important properties: its members may apply at any level and their application may be restricted so that a particular rule R may be prevented from applying in a particular level.

Local rules crucially contain a nonphrasal node which has idiosyncratic properties learned by the language learner on the basis of immediate evidence. The properties in question are properties of Case assignment, values for gender, number and person, tense and aspect properties etc. These properties, as expressed by a local rule, then interact with other components of the grammar to result in variations among different languages. Further, the application of local rules may be specified as restricted to a certain level in one language but not in another. Again, the availability of a local rule at a certain level of the derivation but not at another will, in turn, result in variations in the grammar.

The notion of local rules as defined above will be used extensively in this work. Below, in section 3, we will argue that clitics themselves should be characterized as the output of a local rule, inserting features such as gender, number and person in certain environments. In chapters 3 and 4 we will explore the ways in which local rules interact with parametric variations in clitic phenomena. In chapter 3 section 3 the different properties of šel^v in Modern Hebrew ('of') and pe in Rumanian (an object marker), both dummy Case markers, will be shown to account for interesting differences in extraction configurations between these two languages. In section 4 of chapter 3 it will be shown that differences in extraction

possibilities from clitic-doubling configurations in Rumanian and River Plate Spanish can be accounted for by distinguishing the Case-assignment features of pe in Rumanian from the Case-assignment features of a in River Plate Spanish. These differences will be shown to interact with universal principles of grammar like proper government and the ECP to yield variations in formal properties. In section 4.3 of chapter 3 we will suggest that the availability of clitic doubling with River Plate Spanish indirect objects and the absence of such configurations in French can be derived from the different methods for assigning dative Case employed in these two languages.

In chapter 4 we will show that the reanalysis of pro-drop as discussed in Chomsky (1981) fits naturally into the class of parameters argued for in this study. It will be further shown that the rule of Affix Hopping, which is the local rule used to account for the pro-drop parameter, interacts with yet another local rule, the rule of clitic formation, to account for an interesting interaction between clitic configurations and pro-drop.

2.1. A Note on Genitive Case Assignment

It has been argued (first, to our knowledge, in Emonds, 1970) that the rule which assigns genitive Case is a structural rule. Thus, it is claimed, in a configuration such as (30), genitive Case is assigned to NP₂:

(30)a. $[\text{NP}_1 \text{ NP}_2 [\bar{N}_1 \dots]]$

b. John's house

In (30) it is desirable to claim that the head noun does not assign Case to the possessor John, since John is the specifier of house. If we wish to restrict Case assignment by heads to their complements alone, it is clearly plausible to assume that in (30) genitive Case is not assigned to the possessor by the head noun.

Alongside (30), we have (31), in which John is the complement of the head noun. However, in this instance, of insertion is necessary in order to assign Case to the complement:

(31) the house of John

Thus, (31) seems to provide some additional evidence that nouns in English do not assign genitive Case, even when they can be argued to take complements.

In Semitic languages, however, nouns do seem to assign genitive Case to their complements, as illustrated by the examples in (32):

- (32)a. misrad ha-mora
 office the-teacher
 'the teacher's office' (Modern Hebrew)
- b. maktabu muhammadin
 office Muhamad
 (gen)
 'Muhamad's office' (Standard Arabic)

Furthermore, the assignment of genitive Case in (32) is subject to a strict locality condition, as illustrated by the ungrammaticality of (33) in Hebrew:

- (33) *misrad gadol ha-mora
 office big the-teacher
 'the big office of the teacher'

When strict adjacency is violated, the insertion of a Case marker is required, as in (34):

- (34) ha-misrad ha-gadol ^vsel ha-mora
 the-office the-big of the-teacher
 'the big office of the teacher'

Thus it seems plausible to assume that in the Semitic languages, nouns can assign genitive Case. However, it is clear that an account of the Case-assignment properties of nouns has to take into account the limited distribution of such genitive Case assignment. In particular, such genitive Case assignment occurs only inside \bar{N} . For this reason, let us assume that the genitive Case potentially assigned by head nouns is "activated" by certain environments. Thus, structural configurations will play a role in bringing the genitive Case features of the noun to the surface, but the genitive Case assignment features will still be considered as features of the head noun. On the other hand, in an environment in which the genitive Case features are not activated, the noun cannot assign Case; hence another device is necessary in order to assign genitive Case -- the insertion of a dummy Case marker.

Our proposal has some advantages. First, it enables us to assume that genitive Case assignment in the Semitic languages follows a pattern which is similar to the pattern followed by assignment of other Cases. Typically for a local rule, its application is triggered by a particular environment. Once Case assignment features have been invoked, the assignment of genitive Case is similar to other rules of Case assignment. Second, as we will argue below, clitics show a direct correlation with Case features, in that they are attached to Case-assigning heads of

categories. In languages which allow for clitics on categories other than verbs, such as the Semitic languages, these clitics appear on verbs, prepositions, and also on nouns. If we wish to give a unified account of the distribution of clitics, it is reasonable to assume that at the stage at which the clitic is attached to the head verb, to the head preposition or to the head noun, these heads carry Case features.

Genitive constructions in Modern Hebrew will be discussed in detail in chapter 2. We will elaborate on the various properties of clitics on nouns and the Case-assignment features of nouns, and we will also discuss the notion of strict adjacency for genitive Case assignment. We will refer to genitive Case-assignment features as features of the head noun throughout this study. The reader should, however, bear in mind this short note.

3. A Unified Theory of Clitics

The study of clitics in the light of clitic-doubling phenomena has enjoyed a substantial amount of attention in recent years within the Extended Standard Theory (to mention only a few: Strozer, 1976; Rivas, 1977; Aoun, 1979a; Jaeggli, 1980; Steriade, 1980; Borer, 1980b; and others). In this study, I will suggest yet another analysis of clitics inspired by doubling phenomena as they appear both in the Romance languages (River Plate Spanish, Rumanian) and in Modern Hebrew. The investigation of clitic doubling will motivate a theory of clitics that will then be extended to explain clitic phenomena which are not directly related to doubling in Modern Hebrew, Spanish and French.

A sample of clitic configurations of the kind we will be discussing in this study is given in (35)a-f below. In (35)a-c, we have structures in which the clitic alone seems to satisfy the subcategorization or complementation requirements of a head. (35)d-f present constructions known as "clitic-doubling" constructions. In these configurations, we find a clitic alongside an NP, both of them satisfying the complementation requirements of the head and understood to co-refer. (This coreference is marked henceforth by identical indexing.)¹⁶

- (35)a. lo vimos
 him saw-we
 'we saw him'

(River Plate Spanish; Jaeggli, 1980)

- b. l-am v^uzut
 him-have-I I seen
 'I have seen him'

(Rumanian; Steriade, 1980)

- c. beit-o 'omed 'al ha-giv'a
 house-his stands on the-hill
 'his house stands on the hill'

(Modern Hebrew; Borer, 1980)

- d. lo_i vimos a Juan_i
 him saw-we to Juan
 'we saw Juan'

- e. l_i-am v^uzut pe Popescu_i
 him-have-I seen OM Popescu (OM = object marker)

- f. beit-o_i v^usel ha-more; 'omed 'al ha-giv'a
 house-his of the-teacher stands on the-hill
 'the teacher's house stands on the hill'

A major shift in the study of clitics, which resulted from the consideration of clitic-doubling constructions, has been the abandonment

of the movement analysis of clitics (as suggested, in particular, in Kayne, 1969, 1975; see also Quicoli, 1980, and others). Advocates of the movement analysis would argue that the clitic in sentences (35)a-c is a pronominal element, base-generated in the regular object position and then moved to a position adjacent to the head (the verb in (35)a-b and the head noun in (35)c). However, as pointed out by Strozer (1976), Rivas (1977) and Jaeggli (1980), a movement analysis of this sort simply cannot account in a straightforward way for clitic doubling (and, as pointed out by Jaeggli, 1980, this analysis was in fact constructed to account for the complementary distribution of clitics and complement NP's in French, where the sentences corresponding to (35)d-f are ungrammatical).

Thus, the clitic doubling construction (discussed mainly on the basis of data from River Plate Spanish) motivated a base-generation analysis for clitics. Furthermore, as pointed out by Rivas, base-generation of clitics in the clitic position is independently motivated in benefactive constructions in Spanish, where the clitic cannot correspond to any grammatical argument source. Thus, in (36)a we have two clitics preceding the verb, one corresponding to the benefactive (the leftmost) and one corresponding to the dative argument. However, (36)b, in which these two arguments follow the verb, is ungrammatical.¹⁷

(36)a. me le escribiste una carta
 for-me to-her wrote-you a letter
 'you wrote her a letter for me'

b, *le_j escribiste una carta a María_j a mí
 'you wrote María a letter for me'

For these reasons (see a more complete review of the movement analysis in Jaeggli, 1980), I will join these investigators in rejecting a movement analysis for clitics. However, the movement analysis has one elegant result which base-generation analyses cannot achieve quite as easily. Since the clitic in the movement analysis is considered to have originated in the argument position, the fact that it satisfies the subcategorization frame of the head and is assigned a θ -role by it is captured rather naturally. Furthermore, the coreferentiality (coindexing) between this clitic and the argument position follows in a clear way from a movement analysis, but not from a base-generated one.

Let us review the structure that was suggested for the clitic-doubling configurations both by Rivas (1977) and by Jaeggli (1980). It is roughly as in (37):

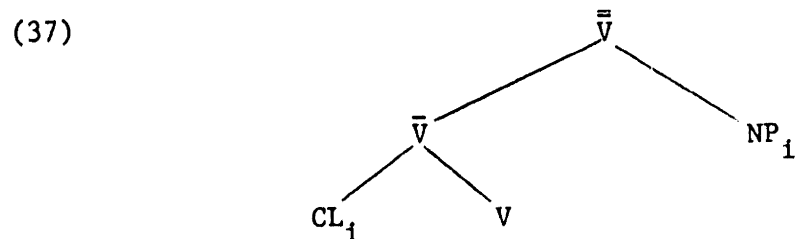

(see Rivas, p. 34; Jaeggli, p. 98, fn. 10)

Jaeggli (1980) argues that in (37), the clitic does not c-command the coindexed NP. (We will return to the motivation for this proposal in chapter 2, section 3 below, and in chapter 3, section 4.2.) The lack of c-command or any other structural relationship which is independently required by the grammar results in the need for a special rule of coindexing and θ -role transmission which is not structure-dependent (see

Jaeggli, p. 66, for the latter).¹⁸ The movement analysis does not confront this problem: due to the requirement that the antecedent c-command its trace, we would either have to alter the definition of c-command so as to incorporate (37) or argue that (37) is not the correct representation of clitic configurations.

Note that even if the definition of c-command is extended to cover the relationship between the clitic and the coindexed NP in (37), this structure still gives rise to some serious questions: what is the relationship between the clitic and the head V? Is the clitic in an argument position (A-position)? Does it enter into the binding conditions?

In this study we will advocate an analysis of clitics in which the clitic c-commands the coindexed NP. Furthermore, it will be shown that, quite independent from the definition of c-command (whose extension is motivated on other grounds), clitics are best characterized as part of the head constituent. In this we will follow Kayne, who suggests that the derived structure of clitic configurations is as in (38). We will differ from Kayne in assuming with Chomsky (the Pisa Lectures) that the relevant structure is base-generated. In this way, clitic-doubling can still be accounted for in a natural way:

(38)

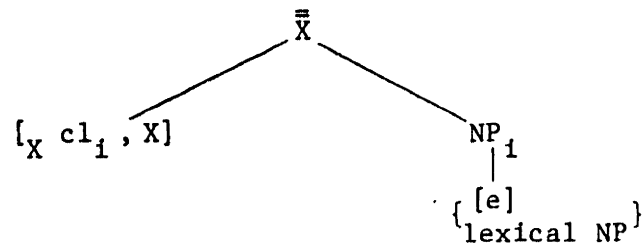

A few things should be clarified with respect to (38). First, the struc-

ture in (38) was suggested for cases in which $X=V$. We will take X in (38) to stand for P and N as well, as will be shown in the discussion in chapter 2 below. Second, note that the clitic in (38) governs (and c-commands) the coindexed NP position. This follows from the fact that it is part of the head. Furthermore, the expansion of (38) in which NP_i dominates $[e]$ (and which corresponds to sentences (35)a-c above) is identical to the output of movement rules. We have an antecedent which is coindexed with an empty category which it c-commands.

In the next sections we will clarify the nature of the combination $[_X cl_i, X]$ in (38) (also notated in this study as "cl+X", with no distinction intended) and the nature of the coindexing which holds between the clitic and the doubled NP position in (38).

3.1. Case Absorption

R. Kayne has observed that constructions such as (35)d-f above -- clitic-doubling constructions -- can only occur if the NP which is doubled is preceded by a preposition. This generalization (which Jaeggli calls "Kayne's Generalization") is accounted for by Chomsky (the Pisa Lectures), Aoun (1979a) and Jaeggli (1980) by assuming that in clitic-doubling constructions the clitic, in a sense to be made precise, absorbs the Case features of the head (the verb in (35)d-e, the noun in (35)f). Following the essentials of their proposals, the structure of clitic-doubling configurations is roughly as in (39):

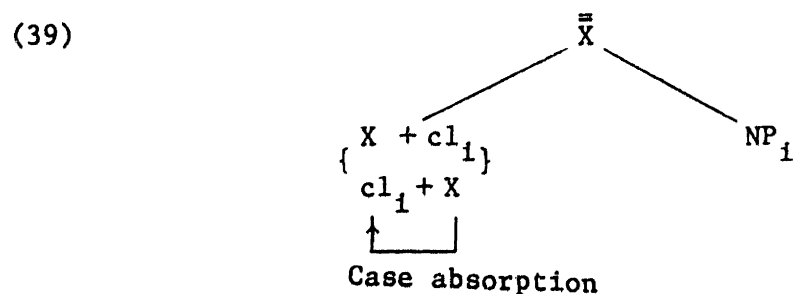

(Note that (39) is neutral with respect to the status of the $X + cl_i$ combination. The status of this combination, assumed earlier (see (38)) to be the relationship between a head and a feature, is not directly relevant here.)

It is argued that in (39), the clitic absorbs the Case features of the category X (or is itself the spell-out of Case features). Note that if we assume the Case filter, it follows that no lexical material can appear in NP_i unless an independent device is found which can assign Case to it, since the Case features of X are absorbed by the clitic. Just such a Case-assigning device is the dummy Case marker, which can be seen in examples (35)d-f: in River Plate Spanish it is the preposition a, in Rumanian it is the object marker pe, and in Modern Hebrew it is the genitive preposition šel. Indeed, the absence of these dummy markers leads to ungrammaticality:

- (40)a. * lo_i vimos Juan_i
 'we saw Juan' (River Plate Spanish)
- b. * l_i -am văzut Popescu_i
 'I have seen Popescu' (Rumanian)
- c. *beit- o_i ha-more_i 'omed 'al ha-giv'a
 'the teacher's house stands on the hill'
 (Modern Hebrew)

In this study, we will adopt the essentials of this intuition. We will assume that, in some sense, the clitic "deprives" the coindexed NP of its Case. In particular, we will assume that the clitic is a spell-out of the Case features of the head, and, as such, is truly a feature of the head. The rule of clitic spell-out is given in (41):

(41) Clitic Spell-Out

$$[{}_X X, \alpha \text{ Case}] \longrightarrow [{}_X X [\alpha \text{ Case}, \beta \text{ gender}, \gamma \text{ number}, \delta \text{ person}]]$$

X = [+V] in Romance¹⁹

X = V, P, N in Semitic

Given our assumptions about the nature of local rules, the rule of Clitic Spell-Out is an insertion rule. In certain configurations, the features number, gender and person are inserted and combined with the already present Case features. Then they are given a specific phonological representation. As a local rule, (41) can apply at any stage of the derivation; in chapter 3, we will discuss some cases in which (41) cannot apply in the base, but rather must apply at S-structure or in the PF component.

Clearly, since we perceive of the clitic as a spell-out of features, we do not expect it to satisfy subcategorization or complementation requirements. Rather, the complement NP node in (35)a-f is generated by the base rules in the usual way, is assigned a θ -role in the usual way, and its relationship to its selecting head is the usual relationship between a selected complement and its head (more on this in subsection 3.2 below).

3.2. The Complement Matching Requirement

Let us now turn to the nature of the coindexing in structures such as (38). Clearly, complementation requirements are met within the government-domain of the lexical head which selects such complements. It follows from the \bar{X} system that every head has to govern its complement. Although this state of affairs is clearly derived from other principles

of the grammar, we would like to state it explicitly. The methodological value of an explicit statement will become clear below, where we discuss structures in which an argument cannot satisfy complementation requirements because it is not governed by the complement-selecting head. Let us then define this structural observation as the government requirement in (42):

(42) A head must govern its complements.

In defining the notions head and complement, we will rely crucially on the \bar{X} system coupled with the assignment of θ -roles. Thus, a head is X^0 , and a complement is an argument that is assigned a θ -role by the head X^0 . In defining complements as those arguments which bear a thematic link to the head, we seek to distinguish between those elements which are selected by the head and are assigned a θ -role by it, and those arguments which may be complements of the head in the broad sense, but nevertheless are not assigned a θ -role by it. Thus, the PP in (43)a is a complement of the verb dedicate, and we will assume that Mary is assigned the θ -role of goal by this verb. On the other hand, in (43)b Paris is assigned a θ -role by from, and the PP is not a complement of the verb in the sense meant above.

(43)a. John dedicated his dissertation to Mary

b. John returned from Paris

(In this work, the term complement, when used without further elaboration, refers to an argument which is assigned a θ -role by a selecting head.

When we refer to complements such as the PP in (43)b, which are not assigned a θ -role by the head, we will distinguish between strictly subcategorized complements (the former sort) and non-strictly subcategorized complements (the latter sort). This distinction is particularly relevant in the discussion of causative constructions in River Plate Spanish.)

Returning now to the structure in (38), recall that the clitic in (38) is part of the head. It is considered as a feature on the head. Since the clitic is part of the head, it governs the doubled NP_i . Furthermore, as part of the head, it takes the doubled NP_i as its complement.

Stowell (1980) suggests that the assignment of θ -roles to complements by a head can be captured if we assume that a complement transfers a referential index to an available thematic slot in the head. Informally speaking, this proposal implies that every head contains as many empty slots as θ -roles which it assigns. These empty slots have to be filled by referential indices transferred from the complement. If the selected complement is not generated, or if it does not have the right θ -role, the empty slot cannot be filled and the derivation is ruled out.

Now let us assume that the structure of the head in (38) above contains two sets of features.²⁰ The first set of features is associated with the head itself. It contains the "inherent" features of the head as well as the "noninherent" features of the head (in the sense discussed in section 2 above). Part of the "inherent" features of the head are the thematic slots, which have to be filled by the referential indices of the complements. The second set of these features are the features of the nominal element attached to the head: the clitic. In particular,

the clitic will have the "noninherent" features Case, gender, number and person which were inserted by the local rule in (41) above. Further, we will assume that, like all nominal elements, it contains a referential index. It is particularly important to separate these two sets of features in the case of a noun head and a clitic. In these cases, the noun will have its own set of "noninherent" features and its own referential index, both distinct from those of the clitic.

A legitimate question is raised with respect to the location of the matrix of features of the clitic in the noun. We would like to argue that the clitic, as formed by the rule in (41), has to be linked to one of the thematic slots available in the head. Thus the structure of the $[_X X, cl]$ combination in (38) is in fact as in (44):²¹

$$(44) \quad [_X \quad X, \quad \begin{bmatrix} \theta_1 \\ \Delta \\ cl_1 \end{bmatrix}]$$

The symbol θ_1 in (44) stands for the particular θ -role assigned by \underline{X} . The empty space indicated by Δ is the space into which the index of the complement has to fit, in accordance with our assumptions about the assignment of θ -roles. The clitic is attached to that position as an additional element, rather than as an element which fills the referential empty slot. Since the clitic is not an argument, it is not a full NP, it cannot be seen as satisfying complementation requirements. Rather, the complement still has to transfer its index.

Now consider a situation in which the complement of X contains an index j and $j \neq 1$. Fitting the index j into the empty slot in (44) will

result in conflicting indices being associated with one thematic slot. Consequently, we argue, the derivation will be ruled out.

Returning now to the obligatory coindexing in (38), we would like to argue that, rather than thinking of the coindexing between the clitic and the complement as a coindexing rule, it should be viewed as a condition on θ -role assignment: if the clitic and the complement do not agree in index, we would have the thematic matrix in (45), which contains conflicting indices, and which is ruled out:

$$(45) \quad * \begin{bmatrix} \theta_1 \\ j \\ cl_i \end{bmatrix}$$

Clearly, some heads select more than one complement, and can assign more than one θ -role. In this case, the complement need not agree with the clitic. Rather, it can agree with the other thematic slot. This situation is illustrated by (46):

$$(46) \quad ktivat_k -o_i \quad 'et \quad ha-ma'amar_j \\ \text{writing-his} \quad \text{acc} \quad \text{the-article} \\ \text{'his writing of the article'}$$

The thematic structure of (46) is as in (47):

$$(47) \quad [N_k \quad \dots \quad \begin{bmatrix} \theta_1 \\ (i) \\ cl_i \end{bmatrix} \quad \begin{bmatrix} \theta_2 \\ j \end{bmatrix}]$$

In (47), the index of ma'amar fills the referential slot in the thematic

matrix of θ_2 . (Presumably θ_2 is theme.) The clitic, on the other hand, is associated with the thematic matrix of θ_1 (presumably agent).

Note that, if the S-structure representation of (47) is as in (46), there is no source for a referential index for θ_1 in (47). However, we will argue that, in fact, the correct S-structure representation of (46) is as in (48):

(48) ktivat_{k-o}_i [e]_i 'et ha-ma'amar

The referential index i is supplied by the empty category (and see appendix to chapter 2 below for some more discussion). For some more discussion of the construction in (46), as well as for some evidence that it contains an empty category, see chapter 2, section 4.

Let us then formulate the Complement Matching Requirement:

(49) Given a thematic matrix T, *T if T contains referential indices i, j, and i ≠ j.

(We will return to the Complement Matching Requirement in the appendix to chapter 2 below, and in chapter 3, section 4.3. In this last section, interesting evidence for the Complement Matching Requirement will be presented based on inalienable possession constructions in Romance.)

Let us now summarize our assumptions with respect to the structure of clitic configurations. We assume the clitic to be the output of a local rule, which inserts number, gender and person features into the feature matrix of a head, when this matrix contains the feature Case. The clitics are a spell-out of Case features, in the sense that once the Case feature is combined with the number, gender and person features inserted

by the Clitic Spell-Out rule, it is given an independent phonological representation and can no longer be transferred to a complement of the head. The clitic, a nominal element, is assigned its own referential index. Since the clitic is part of the head, this referential index and the clitic which carries it govern the complement NP.

The clitic and the NP complement are coindexed with each other, and they agree with each other in gender, number and person. Rather than assume a special coindexing rule, we will assume that this coindexing follows directly from the process of θ -role assignment. If the clitic and the NP are not coindexed, the NP complement cannot receive a θ -role. This conclusion is based on the particular mechanism of θ -role assignment which we assume, which entails the transference of a referential index from a complement to the thematic matrix of the head which selects this complement. Since clitics are linked to thematic matrices, and since they carry a referential index, a conflicting index cannot be transferred to a thematic matrix with which a clitic is associated. We have named this principle the Complement Matching Requirement. This principle ensures the coindexing of the clitic and the doubled element.

Chapter 2 of this study is devoted to making precise the analysis of clitic configurations which we proposed above, as well as to proving its central claims on the basis of empirical evidence from Modern Hebrew. Data from genitive constructions is used to prove the claim that the clitic governs its complement and does not function as an argument. Data from free relatives is discussed, and is shown to indicate that the empty element generated under NP_1 in (38) is [e] rather than PRO. Finally, data concerning extraction both in the syntactic component and in LF is discussed,

which will show that a coindexed clitic can function as a proper governor. In the appendix to chapter 2 we return to the Complement Matching Requirement, elaborating on the way in which θ -role is assigned to an empty element in clitic configurations.

Once the analysis of clitics has been substantiated by discussion of the Hebrew data, we turn in chapters 3 and 4 to its application to different languages, to the range of parametric variation which this analysis allows and to the way in which it interacts with other phenomena.

FOOTNOTES: CHAPTER 1

1. The name "Pisa Lectures" refers to a manuscript of the original lectures on government and binding given by N. Chomsky at the GLOW conference, Pisa, April 1979. This manuscript was prepared by J-Y. Pollock and H. Obenauer. These lectures were then expanded in a book, referred to in this study as Chomsky (1981). We refer to the "Pisa Lectures" only when we discuss matters whose treatment differs in the earlier manuscript from their treatment in the more recent book.
2. As is clear from the model in (2), the terms PF and LF denote levels of representation. However, these terms are often used in the literature to refer also to the set of rules which map S-structure representations onto LF and PF respectively. In this study, the terms "LF" and "PF" (as well as "LF component" and "PF component") are often used in this fashion.
3. Chomsky (1981) suggests that empty categories are in fact tokens of the same type. As such, they are all base-generated as a set of features (gender, number and person features) without a phonetic matrix. Their differing behaviour is then determined on the basis of their differing properties at S-structure (see chapter 2, appendix, for some discussion). In this respect, it is clear that restricting the notion "argument" to exclude traces is only relevant at S-structure, and not at D-structure, where these empty elements cannot be distinguished from PRO.
4. The definition of government in (8) is a development of an idea of Aoun and Sportiche (1981)a. The intuition behind their definition is that

a head governs everything in its maximal projection. In (8) this intuition is expanded to allow government of adjoined structures as well. The definition of c-command in (9) seeks to capture the intuition behind the definition of c-command in Reinhart (1976), while substituting the notion "branching" used by Reinhart with the notion "projection of the same category".

5. The definition of governing category in (13) is, in fact, a tentative formulation, later replaced in Chomsky (1981) by a definition of a "binding category", in which the government requirement is derived from other factors. For our purposes, however, the definition in (13) suffices. Similarly, we will not discuss in this study the motivation for the notion accessible SUBJECT in (13), since this issue is by and large irrelevant to topics discussed in this study. For extensive discussion of these topics see Chomsky (1981), Aoun, Vergnaud and Zubizarreta (forthcoming).

6. In arguing for the Case filter as a separate entity located in the phonological component we differ from Chomsky (1981), who argues that the Case filter should be derived from the notion of chain coupled with the Visibility Hypothesis briefly mentioned in this section. We will return to this matter in great detail in the appendix to chapter 2.

7. The transliteration of Hebrew used in this study seeks to characterize spoken Hebrew. Thus, some distinctions which are preserved in the orthography (and perhaps preserved in underlying forms as well) are eliminated in our representation. This transliteration is not intended as a phonological characterization of underlying segments. The table in (1) is the Hebrew

alphabet and the corresponding transliteration:

(i)	Orthog.	Transl.	Orthog.	Transl.	Orthog.	Transl.
	א	'	ט	t	י	'
	ב,בּ	b, v	י	y, i	פ,פּ	p, f
	ג	g	כ,כּ	k, x	צ	c
	ד	d	ל	l	ק	k
	ה	h	מ	m	ר	r
	ו	v, o, u	נ	n	ש,שׁ	v, s, s
	ז	z	ס	s	ת	t
	ח	x				

8. The generalization that doubling is possible whenever a preposition appears preceding the doubled element is due to Kayne. We will return to this point in section 3 below.

Interestingly, rule (20) is a general rule in Lebanese Arabic, which inserts the preposition la in front of [NP, VP], [NP, PP], and [NP, NP]. The preposition la, however, is never inserted preceding a nominal element in the subject position. For some discussion, see Aoun (forthcoming).

9. The definition in (21) only differs from that of Emonds (1976) in substituting the word rule for the word transformation used by Emonds.

10. The government requirement for local rules seeks to capture the dominance condition of Emonds (1976; 1980). It differs from the dominance condition, however, in preventing local rules from applying to two adjacent elements in two different maximal projections. This follows from the definition of government assumed in section 1 above. The empirical consequences of this difference will not be pursued here.

11. Local rules which delete the node C are not discussed in this study. If, indeed, the deletion component is located in PF (see section 1 for some discussion), then the application of local rules which delete elements is universally restricted to apply only in that component. Such a restriction is compatible with our assumption about the universal nature of local rules.

We also do not discuss local rules which move or insert the node C'. It is, perhaps, worth considering the question of whether such rules are local rules at all. Note that once C' is moved, this movement is plausibly subsumed by "Move α ". Furthermore, if C' is a term of \bar{X} , it is plausible to assume that it leaves a trace once moved. As for insertion rules, since C' is a term of the \bar{X} notation, it is probably inserted as part of the regular base rules. Thus, a more restrictive formulation of the definition in (21) would restrict the target of the rule to C, and would specify that C' can only serve as an environment. For a different view on these matters, see Emonds (1980).

12. We will crucially assume that nominative Case assignment is not a local rule. For some discussion, see chapter 4, sections 2 and 3.

It is not immediately clear if the rule in (25) is best characterized as a rule moving a grammatical feature or as an insertion rule. Note that only if we characterize it as a movement rule will we capture the uniqueness of Case assignment. In this work, we will assume that (25) is a movement rule and that it is part of the syntactic component. However, (25) can apply either prior to "Move α " or following it. As such, it is

equivalent to Case marking in D-structure (when it applies prior to "Move α ") or to Case marking at S-structure (if it applies following "Move α "). Hence we will refer to Case marking as a phenomenon of D-structure or of S-structure. The reader should, however, bear this comment in mind with respect to this usage.

13. For discussion of exceptional Case marking, see Chomsky (1980), where it is suggested that the right way to capture the property of verbs like believe and expect which allows them to assign Case to a subordinate subject is to assume that they take a non-maximal projection as their complement. This non-maximal projection then permits the application of (25), since the subject is now adjacent to and governed by the verb. This proposal, although it may be right, does not fall within the restricted class of parameters which we argue for in this study.

Kayne (1980)b argues that the effects of exceptional Case marking are achieved by the presence of a \emptyset -complementizer which assigns accusative Case. This account of the accusative subject in (26) does fall within the restricted class of parameters we argue for.

14. This account is in fact neutral with respect to the question of whether the Case requirements are met by Case-marking the WH elements or by Case-marking the variable left behind (see Borer, 1981, for discussion). If one adopts the requirement that variables must have Case (as a general principle of grammar or as a consequence of the Visibility Hypothesis), it is still clear that if who_i in (26)b is not assigned

Case in the base, there is no way to have a Case-marked variable in the subject position, assuming that empty elements cannot be Case-marked directly. If, on the other hand, accusative Case is assigned to who in the base, one could assume that after the fronting of the WH element its trace retains a copy of the Case that was assigned to it by expect prior to the application of "Move α ". Since the trace retains both an index and the set of ϕ -features of its antecedent (ϕ -features = gender, number and person features), it is not implausible to argue that it retains Case marking as well.

15. A suggestion similar to ours is advanced in Emonds (1980), where it is argued that grammatical formatives may be required to satisfy contextual subcategorization frames after transformations apply. We differ from Emonds, however, in assuming that the possibility of restricting the insertion of grammatical formatives follows from a more general property of local rules, rather than from the property of a particular grammatical formative.

16. In examples (35)c and (35)f it is a noun which takes a complement rather than a verb (see subsection 2.1 above for a discussion of the argument as a complement in these cases). One may raise a question with respect to the availability of complementation requirements and θ -role assignment by head nouns, when the complement is the possessor. Clearly, one has to allow for complementation and θ -role assignment by head nouns to be specified in the case of derived nominals, as in (i):

(i) the destruction of the city

It is not clear, however, if the same treatment can be given in the case of (ii):

(ii) the tail of the dog

In this study we will assume that in the case of (ii) as well as in the case of (i), the complements are best characterized as selected by the head noun and as assigned a θ -role by it. The question of whether this assignment is triggered by a structural environment, as we suggested for the rule of genitive Case assignment in Semitic (see section 2.1 above), or whether these complementation requirements are properties of particular lexical items is left open in this study. For the purposes of this study it suffices to state that we hold all complementation requirements which are valid for verbs and prepositions to be valid in cases such as (35)c and (35)f, regardless of the derivational history of these requirements. This is particularly important for the government requirement and the Complement Matching Requirement discussed in section 3.2 below.

17. Sentences (36)a-b interact with clitic-doubling phenomena in a way that will be discussed in chapter 3, section 4 below. Essentially, each of the clitics can be doubled, and a benefactive NP cannot appear without a corresponding clitic. This state of affairs results in the following paradigm:

(i) le_i comiste la torta a Juan_i
'you ate the cake for Juan'

(ii) *comiste la torta a Juan

However, if there is a dative object in the sentence, the dative clitic can only be interpreted as correferential with the non-benefactive dative object:

- (iii) le escribiste una carta
 'you wrote a letter to her'
 *'you wrote a letter for her'

If there are two clitics, there can be only one dative object, and it must be coreferential with the non-benefactive clitic:

- (iv) me le_j escribiste una carta a María_j
 'you wrote a letter to Maria for me'
- (v) *me le escribiste una carta a mi
 for me
- (vi) *me_i le_j escribiste una carta a María_j a mi
 (ibid.)

For the purposes of our introduction, it suffices to say that in (36)a in the text, as well as in (iv), no movement or copying rule can easily account for the distribution of clitics.

18. One could argue that no special rule is needed in this case. Instead, θ -role assignment and indexing are done at random, and any combination which does not assign an identical index and identical θ -role is ruled out by the Projection Principle, (5) in text. Recall that the Projection Principle postulates that lexical specifications must be adhered to at every level. It follows that if a separate index or θ -role is assigned to each member of the pair clitic / NP, the lexical specifications according to which the verb in question assigns only one θ -role

to one referential expression would be violated. Note, however, that if this is the case, we would require a checking mechanism at some level, ensuring that the Projection Principle is obeyed. The lack of structural relationship between the clitic and the NP would then be reflected as a special, non-structure-dependent checking mechanism, rather than as a special, non-structure-dependent coindexing and θ -role assignment rule.

19. Clitics on adjectives are not discussed directly in this study. Note that in the Romance languages they never surface on the adjective itself. Rather, they are attached to the auxiliary verb. This is due to the fact that the Romance languages show obligatory clitic climbing in the case of auxiliaries. For some discussion of clitic climbing, see chapter 3, section 4.1. This treatment carries over to adjectival clitics as well.

20. This idea was suggested to me by N. Chomsky.

21. The configurations in (21) raise some interesting questions with respect to the internal structure of the word containing the clitic and the head. Williams (1981) suggests that affixes of derivational morphology should be viewed as the heads of words. This, however, does not hold for the affixes of inflectional morphology. Since the clitic is composed of features of inflectional morphology, we do not expect it to be the head of the word in (44). Rather, we expect X to be the head. The internal structure of (44) from a morphological point of view will not be pursued in this study.

CHAPTER 2: CLITIC GOVERNMENT--AN ANALYSIS OF CLITIC DOUBLING

1. Introduction

Clitic constructions in Semitic languages have not been widely researched within the framework of Extended Standard Theory. This chapter is an attempt to shed some light on clitic constructions and clitic-doubling as they appear in Modern Hebrew. Essentially, this chapter is of an introductory nature: we present here a detailed analysis of clitic configurations based on data from Modern Hebrew. In chapters 3 and 4 below it will be shown that, given a few parametric variations, this analysis can be extended to account for clitic configurations in the Romance languages and in Arabic. It will be shown that, although the clitics in the Semitic languages exhibit different behaviour from the clitics in the Romance languages, there are nevertheless great similarities: in particular, it will be shown that the clitics themselves are the same -- a spell-out of features on the head of their phrase -- and that the relationship between the clitic and the doubled NP (or gap) is always that of government.

Recall that we are assuming that the structure of clitic configurations is as in (1):

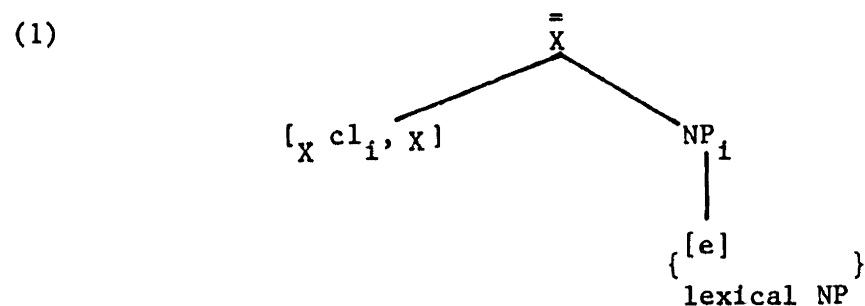

Further recall that we are assuming that the way to capture Kayne's generalization, as stated in (2), is by thinking of the clitics as 'absorbing' the Case features of the head, by the operation of the local rule in (3):

- (2) An object NP may be doubled by a clitic only if the NP is preceded by a preposition.
- (3) $[_X X, \alpha \text{ Case}] \rightarrow [_X X, [\alpha \text{ Case}, \beta \text{ person}, \gamma \text{ gender}, \delta \text{ number}]]$

Assuming the Case filter as in (4):

- (4) *NP
[-Case]

then no lexical material can appear in NP, unless an independent device can assign Case to it. Such an independent Case-assigning device is a dummy Case marker. Further recall that we would like to assume that the clitic does not satisfy complementation requirements.

Rather, the complement node (the subcategorized object or indirect object in verbal configurations and the complement NP in genitival constructions) has to be generated independently. Once it has been generated, it is governed both by the verb and by the clitic (the clitic being a feature on the head) and cannot include an index which conflicts with that of the clitic. This latter restriction we have called the Complement Matching Requirement, which was formulated as in (5):

- (5) Given a thematic matrix \underline{T} , * \underline{T} if \underline{T} contains referential indices \underline{i} , \underline{j} and $i \neq j$.

This chapter is devoted to proving the different aspects of this

analysis. In section 2 it will be argued that the relationship between the clitic and the coindexed NP is structurally statable in terms of government: the clitic has to govern the doubled NP. The empirical evidence substantiating this argument comes from the different properties of genitival constructions in Modern Hebrew. It will be further shown that the clitic does not enter into the binding conditions and that hence it is best characterized as a feature on the head, as in (1), rather than as a separate, base-generated nominal node.

In section 3 I will show that there is direct evidence that an empty category can appear in the NP_1 position in (1). The evidence will rely crucially on the availability of extraction from that position in free relatives in Modern Hebrew. By showing that [e] can appear in this position, and assuming the Empty Category Principle (see chapter 1 for discussion), it will be demonstrated that the NP_1 position in (1) has to be governed, and, in fact, properly governed.

In section 4 I will address directly the issue of proper government of NP_1 when it is expanded as [e]: it will be argued that only the coindexed clitic can properly govern this position, indicating again that the clitic governs the NP_1 position and should be viewed as part of the head. The availability of proper government by the coindexed clitic vs. the inavailability of proper government by nouns will be shown to interact in an interesting way with the scope of quantifiers in genitival constructions.

In the appendix we will elaborate on the way in which θ -role is assigned to doubled elements. While doing so, we will address issues such as A-chains and the Visibility Hypothesis, and indicate the way in which the Complement Matching Requirement suggested above interacts with these notions.

2.1. The Construct State: General Properties

The Construct State in Modern Hebrew indicates genitival relations between the head noun and the complement noun. The phrase in (6) has roughly the structure in (7):¹

- (6) *beit ha-mora*
 house the-teacher(fem)
 'the teacher's house'

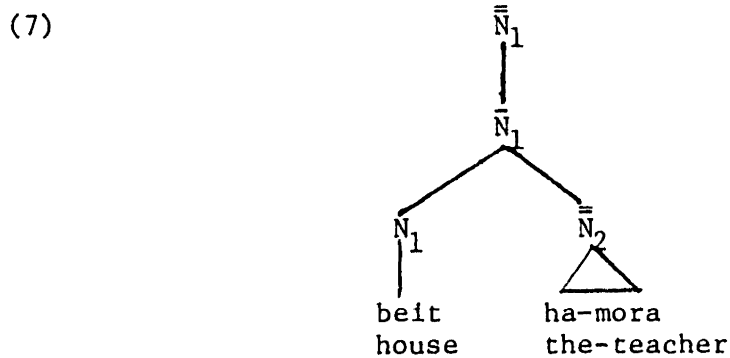

(7) yields itself to further embedding:

- (8) *delet beit ha-mora*
 door house the-teacher
 'the door of the house of the teacher'

(8) has the structure shown in (9):

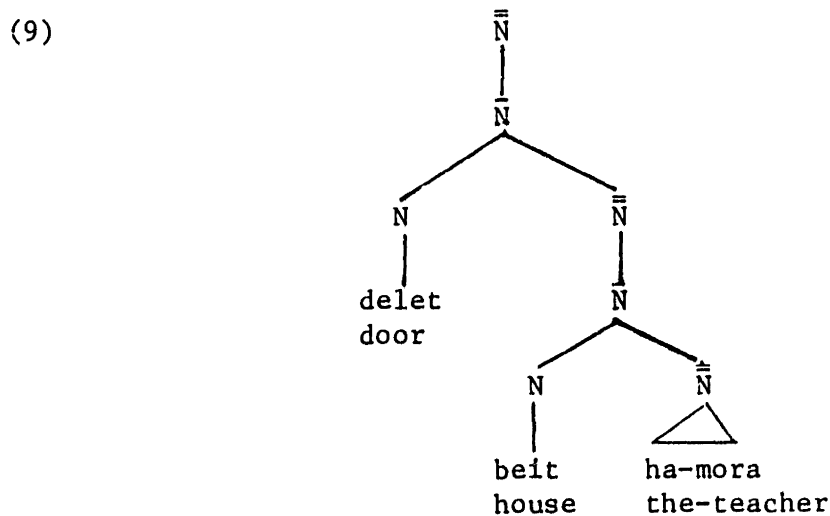

- (10) yadit delet beit ha-mora
 handle door house the-teacher
 'the handle of the door of the house of the teacher'
- (11) ceva yadit delet beit ha-mora
 color handle door house the-teacher
 'the color of the handle of the door of the house of the teacher'

Note that all these structures are right branching. Thus they are given a specific bracketing; for example, the head of a complex such as (11) is ceva 'color, and its complement is 'the handle of the door of the house of the teacher'. The head of the complement is yadit 'handle, and its complement is 'the door of the house of the teacher'. This is the only way to form construct states. (This requirement for right branching is captured in our diagrams by generating the complement NP under \bar{N} rather than under the \bar{N} node. This notation, however, is only a suggestion for capturing this restriction. Offering a full explanation for this property is outside the scope of this study, but as a partial explanation, let us assume that genitive Case can be assigned to \bar{N}_2 in configurations such as (7) only if it is strictly adjacent to N_1 -- strictly adjacent in this context defined as the first node which dominates N_1 dominates \bar{N}_2 . For some account of genitive Case assignment see chapter 1, section 2.1 above. For some analyses of the construct state which address the 'right branching' requirement, see Drescher (1973), Aoun (1978) and Berman (1978) and references cited there.)

An interesting property of the construct state follows from the requirement of right branching. Since in all cases the head node has to remain 'bare' and cannot branch, it cannot be directly modified. Any

modification, either by a determiner or by an adjective, would constitute branching. For adjectives, this situation is exemplified by the ungrammaticality of (12):

(12) *ceva yadit yafa ha-delet
color handle beautiful the-door

(12) would have the structure in (13), in which the complement NP cannot be generated under \bar{N} ; hence the sentence is ungrammatical:

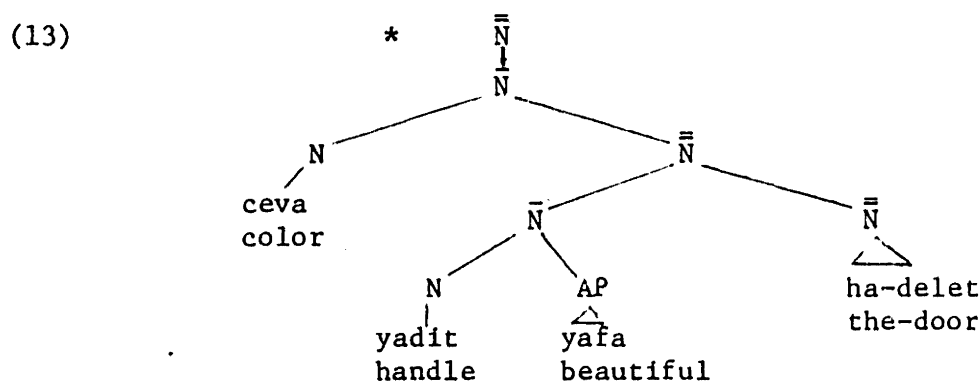

Thus, in order to specify that the color of the handle is beautiful, yafe, the adjective would have to appear at the end of the complex:

(14) ceva yadit delet beit ha-mora ha-yafe
color handle door house the-teacher the-beautiful
'the beautiful color of the handle of the door of the house of
the teacher'

In fact, the modifying adjective can be construed as belonging to any level of bracketing in a multiply embedded structure; thus (14) is in fact ambiguous. The adjective yafe could refer to any noun in the complex which agrees with it in gender and number. Since in this case it is masculine singular, it could refer to the color or to the house itself, both being masculine singular. (Hebrew does not have neuter gender.) These two interpretations would have bracketings (15) and

(16), respectively:

(15) [ceva [yadit [delet [beit [ha-mora]]]]] ha-yafe]
 color handle door house the teacher the-beautiful
 'the beautiful color of the handle etc.'

(16) [ceva [yadit [delet [beit [ha-mora] ha-yafe]]]]
 color handle door house the-teacher the-beautiful
 'the color of the handle of the door of the beautiful house etc.'

Similarly, if we used the feminine counterpart of yafe, yafa, it could be construed with yadit 'handle'; delet 'door'; or ha-mora 'the teacher', all being feminine singular.

A similar restriction holds for determiners. Only a non-head constituent in structures such as (9) can be accompanied by a determiner. This means that only the last NP in a chain of construct nouns can be definite.

This situation is exemplified by the contrast between (17) and

(18):

(17) ceva yadit ha-delet
 color handle the-door
 'the color of the handle of the door'

(18) *ceva ha-yadit ha-delet
 color the-handle the-door

The ungrammatical sentence (18) would have the ill-formed structure in (19):

(19)

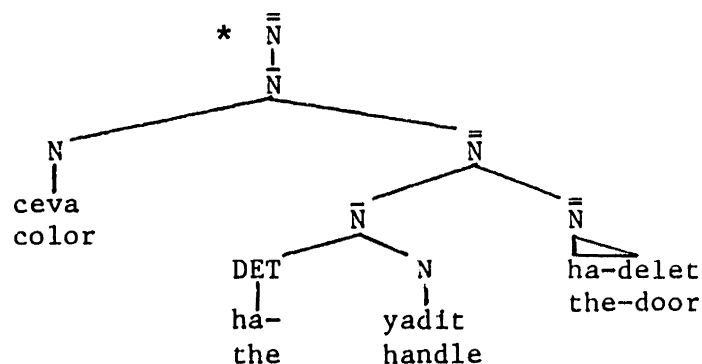

On the other hand, since in (17) the determiner can only appear attached to the last constituent, the sentence is vague with respect to the identity of the definite element: it can be the last constituent alone, 'the door', or it can be the last constituent combined with one or two of the others. (20)a-d is the list of possible interpretations for (17):

- (20)a. a color of a handle of the door (if the door is multi-handled)
 b. a color of the handle of the door (if the handle is multi-colored)
 c. the color of the handle of the door
 d. the color of a handle of the door

If, on the other hand, no determiner appears at all, as in (21), both head noun and complement NP are construed as non-definite:

- (21) beit mora
 house teacher
 'a teacher's house'

As demonstrated by (12) and (18) above, any attempt to break the succession of bare nouns in a phrase such as (11) with a modifier or a determiner will yield ungrammaticality or, alternatively, will bring about the "closure" of the construct state. Any further genitival relationship will then have to be expressed in a different way: by using the genitival preposition vel:

(22) *ceva ha-yadit ha-yafe delet beit ha-mora
 color the-handle the-beautiful door house the-teacher

(23) ceva ha-yadit ha-yafe vsel delet beit ha-mora
 color the-handle the-beautiful of door house the-teacher
 'the beautiful color of the handle of the door of the house of
 the teacher'

(23), presumably, has roughly the structure in (24):²

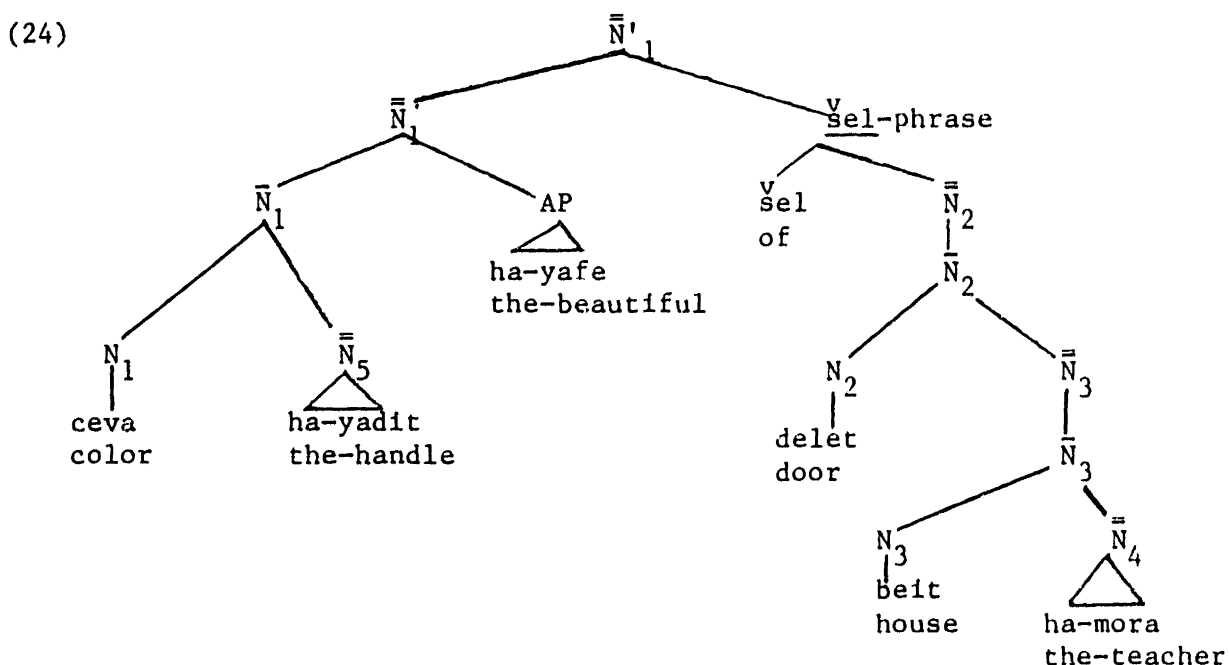

Nouns in Modern Hebrew, as in other Semitic languages, take clitics; following our analysis in the introduction, we would like to assume that these clitics are a spell-out of the genitive Case features, in the sense of (3) above, otherwise assigned to the complement NP. (In Standard Arabic, for instance, the complement NP is overtly marked as genitive.)³ Thus, we will assume the combination noun+clitic, as in (25), to have the structure shown in (26):

(25) beit-a
house-her
'her house'

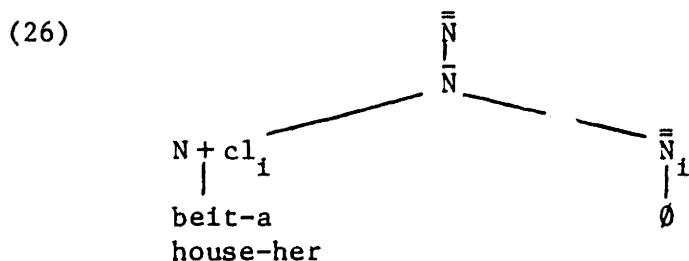

(We shall return to the symbol \emptyset and to what it stands for below, in sections 2.3 and 2.4.)

The structure of (26) seems to be the one involved in clitic doubling, in the sense discussed above. Thus, parallel to (6) and identical to it in meaning we have (27):

(27) beit-a_i ^vsel ha-mora_i
house-her of the-teacher
'the teacher's house'

(27), following our assumptions about the structure of clitic-doubling constructions, has the structure in (28):

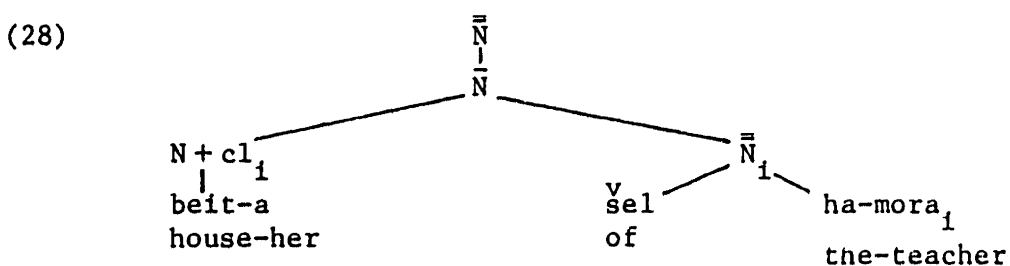

Recall that we are assuming that the clitic in (28) absorbs the genitive Case that otherwise would be assigned to the complement NP. Hence it is necessary for ^vsel to be inserted in order to assign Case to the co-indexed N̄_i. Failure to insert ^vsel would lead to ungrammaticality, which

we have predicted using the Case filter:

- (29) *beit-a_i ha-mora_i
 house-her the-teacher

2.2. On the Differences between Clitics and Lexical NP's

Recall that earlier we argued that $\check{s}el$, the genitival preposition meaning roughly 'of', appears in another environment in Modern Hebrew. When a construct state is "broken", $\check{s}el$ is available in order to express genitival relations in a way syntactically different from that expressed by the construct state. In fact, the availability of $\check{s}el$ in Modern Hebrew results in two alternate means for expressing genitival relations: by means of the construct state, as in (6) (repeated here as (30)a), or by means of the genitival preposition $\check{s}el$, as in (30)b:

- (30)a. beit ha-mora
 house the-teacher
 'the teacher's house'
- b. ha-bayit $\check{s}el$ ha-mora
 the-house of the-teacher

The structure of (30)b can be roughly illustrated as in (31) (and see also (24) above):

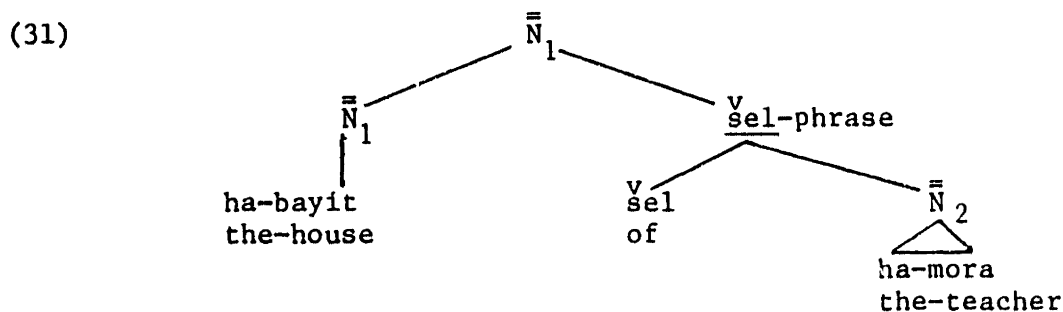

(Note that in (31) ha-bayit, 'the house' is construed as the head of the adjoined phrase as well. We shall return to this point below; see also fn. 2)

The nature of the vsel phrase in (31) and in (24) is left open. In fact, note that we seem to have now two sources for vsel: one is in structures such as (31) and (24), where the vsel seems to head a phrase, perhaps a PP, and structures such as (28), in which we would like to argue that the vsel is inserted for Case purposes and does not change the NP nature of the category which it is adjoined to.

The structure in (28) shares an important property with the structure in (31): both behave as "broken" construct states in the sense that they do not have to be uniquely right-branching. Thus in (28) the complex noun+clitic can be modified directly by an adjective as in (32)a and in (31) 'the house' can be directly modified as well (as in (32)b):

- (32)a. beit-a₁ ha-yafe vsel ha-mora₁
 house-her the-beautiful of the-teacher
 'the beautiful house of the teacher'
- b. ha-bayit ha-yafe vsel ha-mora
 the-house the-beautiful of the-teacher
 'the beautiful house of the teacher'

Note that the intervening adjectival material in (32)a does not prevent the coindexing of 'her' and 'the teacher'. In fact, this coindexing seems completely oblivious to any stacking of intervening adjectives:

- (33) beit-a₁ ha-yafe ve-ha-meruxak min ha-'ir vsel ha-mora₁
 house-her the-beautiful and-the-far from the-city of the-teacher
 'the teacher's house which is beautiful and which is far from the city'

The availability of left-branching for phrases such as (27) seems to present a problem for our proposal that (28) is the right structure for these phrases. Given the requirement that \bar{N} complements be generated under \bar{N} , as in (9) above, it is not clear why adjectival material cannot appear between N and \bar{N} in (9), but it can appear between the $N+cl$ and \bar{N} in (28), if (28) is indeed the right structure. Furthermore, the need for two distinct sources for the preposition \underline{sel} indicates that perhaps some generalization is being missed.

One could argue on the basis of these problems that a more plausible structure for (27), and in general for clitic-doubling cases in Modern Hebrew, would be one closely resembling the structure in (24) and (31). Proponents of such an analysis would argue that the clitic on the noun in cases such as (27) is not a spell-out of a feature, but rather, a base-generated pronominal which appears in the regular argument position, as in (34):

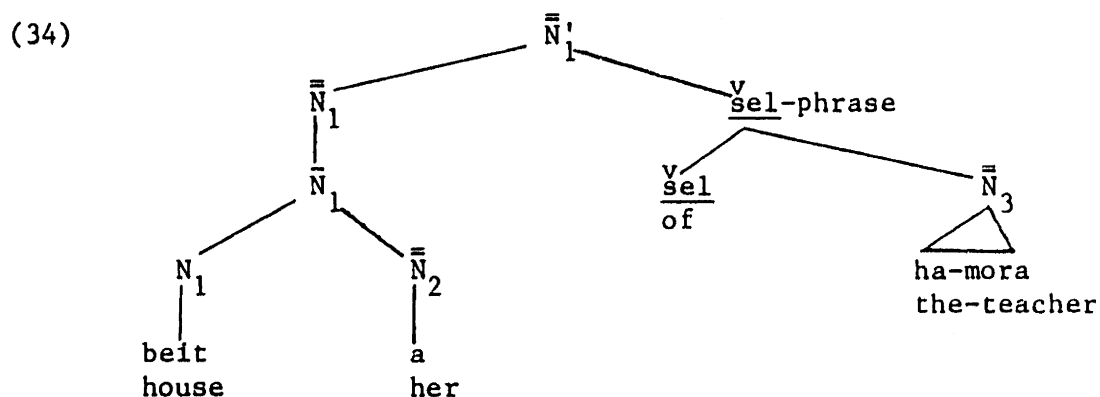

(Note that this is essentially identical to (24) above.)

Since Modern Hebrew does not have clitic climbing or any other evidence that would indicate that the clitic is not in the original argument position, it would seem that, in fact, there is no evidence that any syntactic operations apply to (34). The morphological process of adjoining the clitic to the head would be a non-syntactic phenomenon which is not related to the insertion of \bar{V}_{sel} or to any other syntactic process.

There are, however, some important differences between (32)a and (24) above, which clearly indicate that the two configurations have to be given a somewhat different account. These differences highlight the fact that construct states in which the complement is a full lexical NP (as in (30)a) should be treated differently from those in which it is a pronominal clitic (as in (25)). In the rest of this section these differences will be investigated. It will be shown that the relationship which holds between the clitic and the NP of the \bar{V}_{sel} phrase in sentences such as (32)a is entirely different from that which holds, say, between \bar{N}_3 and \bar{N}_2 in (24) above. If, indeed, the structure of (32)a was as in (34), we would not expect this difference. This difference consists of obligatory coindexing of the clitic and the NP complement in (32)a which is impossible in (24) and which is stated in clear syntactic terms: it can only hold if the clitic governs the complement NP.

Before turning to the matter of coindexing, which involves rather complicated data, one point where clitic complements and lexical NP complements clearly differ should be pointed out: whereas a chain of construct states with lexical NP's can always be expanded, providing

that the structure remains right-branching (cf. examples (10)-(11) above and structure (9)), the introduction of a clitic brings about the immediate "closure" of the construct state. Thus (35) in a reading that would correspond to (8) above is ungrammatical (and see also (29) above):

(35) *dalt-o ha-mora
 door-it the-teacher
 'the door of it of the teacher'

The ungrammaticality of (35) vs. the grammaticality of (8) would follow immediately if we assume that the clitic absorbs the Case features, since in this case, 'the teacher' in (35) would not be assigned Case and thus would violate the Case filter. On the other hand, if one assumed that clitics occupy the same position that full lexical NP's do, having the structure in (9) for (35), this fact cannot be readily explained.⁴ Now let us turn to the coindexing argument.

Consider the following sentence, which consists of the construct state along with a sel phrase:

(36) tmunot ha-yalda ^vsel ha-mora
 pictures the-girl of the-teacher(fem)

(36) can be construed with either of the following bracketings:

- (37)a. [pictures [[the girl] of the teacher]]
 'the pictures of the teacher's daughter'
- b. [[pictures [the girl]] of the teacher]
 'the girl's pictures of the teacher'

Now compare (36) with a phrase in which yalda, 'girl', has been replaced by a feminine clitic:

(38) tmunote-ha $\overset{v}{s}$ el ha-mora
 pictures-her of the-teacher(fem)

(38) cannot have the meaning of either (37)a or (37)b: the clitic ha in (38) can only refer to the teacher, ha-mora. In other words, (39)a-b are not possible meanings of (38):

(39)a. her_j pictures of the teacher_i
 b. the teacher's_i pictures of her_j

In fact, if the clitic is replaced by a masculine one (referring, say, to 'boy', yeled), the sentence results in ungrammaticality, due to the fact that the masculine clitic cannot be coindexed with ha-mora, 'the teacher', which is feminine:

(40)a. tmunot ha-yeled $\overset{v}{s}$ el ha-mora
 pictures the-boy of the-teacher(fem)
 'the pictures of the son of the teacher'
 'the boy's pictures of the teacher'
 b. *tmunot-av $\overset{v}{s}$ el ha-mora
 pictures-his of the teacher
 'his pictures of the teacher'
 'the teacher's pictures of him'

An interpretation of (38) in which the clitic is disjoint from the complement of the $\overset{v}{s}$ el phrase, as well as a grammatical reading of (40)b, is possible only with a very sharp intonation break between the clitic and the $\overset{v}{s}$ el phrase, and even then it is only very marginal. Thus, it seems, we have an obligatory coindexing of the clitic with the complement object of $\overset{v}{s}$ el in structures which correspond to (38) but not in structures which correspond to (36).

2.3. The \bar{S}_{el} Phrase and the Position of the Clitic

We observed above that the coindexing relationship which holds between the clitic and the object of \bar{S}_{el} in sentences such as (38) is obligatory. We further argued that such coindexing does not hold obligatorily between the NP which is the complement of the construct state in (36) (ha-yalda 'the girl') and the object of the \bar{S}_{el} phrase (ha-mora 'the teacher'). In fact, such coindexing between these two lexical NP's is grammatically impossible even if it is logically possible. Thus, for instance, if the object of \bar{S}_{el} is a pronominal element and the complement of the construct state is a full NP they cannot be understood to co-refer:

(41) *beit ha-mora₁ \bar{S}_{el} -a₁⁵
 house the-teacher of-her

(41) has only two possible interpretations. The first, more obvious one, can be translated as 'the house of her teacher' and is completely irrelevant for our purposes. The second one, which has the structure in (43) (which roughly corresponds to (24) above) means 'the teacher's house which she owns'. In this latter reading, the teacher cannot be coreferential with she. The unavailability of coreference between \bar{N}_2 and \bar{N}_3 in structures like (43) below may follow from the binding conditions, if we assume that the relevant definition of c-command is a slightly revised version of the definition of c-command suggested in Chomsky (1981):

(42) C-command (definition)

α c-commands β iff:

- i. α does not contain β
- ii. Suppose that $\gamma_1, \dots, \gamma_n$ is a sequence such that:
 - (a) $\gamma_n = \alpha$
 - (b) $\gamma_i = \alpha_j$
 - (c) γ_i immediately dominates γ_{i+1}
 - (d) for every $\gamma_j, j \geq 1, \gamma_n$ is the head of γ_j
then if δ immediately dominates α then either
 - I. δ dominates β ; or
 - II. $\delta = \gamma_1$ and γ_1 dominates β

(42) differs from the definition suggested by Chomsky only in introducing clause (d), which requires that c-command be effectively contained within the domain of the head of the phrase. Note that such a definition would still allow the head to c-command into adjoined phrases (for instance, it would allow the verb to c-command postposed subjects adjoined to VP in Italian): although the head is dominated by a maximal projection which does not dominate the adjoined phrase, it is the head of the maximal projection which dominates the adjoined phrase. Hence it c-commands it. On the other hand, the definition in (42) would prevent a head of a maximal projection from c-commanding an element which is in another maximal projection which has a different head but which is of the same categorial type. This situation holds in structures such as (43): we would like to block the head of \bar{N}_2 (as opposed to the \bar{N}_2 itself) from c-commanding the v_{sel} phrase.⁶

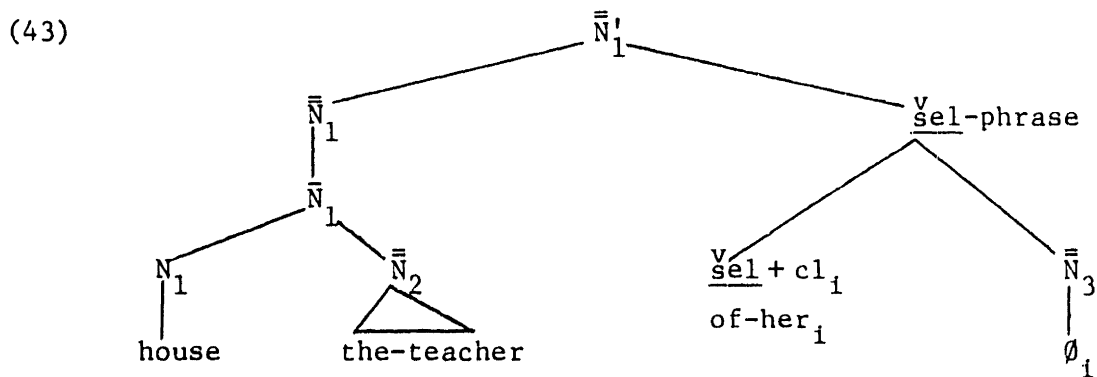

Adopting the definition in (42), \bar{N}_2 in (43) c-commands \bar{N}_3 . Thus both these nodes fall under the binding conditions and are marked disjoint in reference. If this is indeed the case we expect it to be possible to place a reflexive anaphor in the \bar{N}_3 position, bound by \bar{N}_2 , and this is in fact possible, as demonstrated by (44). (The marginality of (44) is, I believe, due to independent reasons. See fn. 7 and the discussion in section 4.2 below).⁷

(44) ?re'iyat ha-mora V_sel 'acma
 view the-teacher of herself
 'the-teacher's view of herself'

Thus it seems that the impossibility of coindexing between \bar{N}_2 and \bar{N}_3 can be attributed to the binding conditions, if we assume the definition in (42). Note, however, that if this is indeed the case, then obviously we can no longer hold that the clitic in sentences such as (38) occupies the same position that the lexical NP ha-mora, 'the teacher', occupies in (43): one of them enters the binding conditions and the other one does not. Hence it seems obvious that the structure of clitic-doubling configurations such as (38) cannot be represented by (43) or (34) above. In fact, since definition (42) would include any possible argument position inside \bar{N}_1 in (43), we have to conclude

that the clitic, in fact, is not in an argument position. This leads us back to the conclusion that the clitic is, as we suggested before, a feature on the head noun.

What is the status of the $\overset{v}{s}el$ phrase? In diagram (28) above, $\overset{v}{s}el$ was marked as an inserted element, which does not change the NP-status of the category that it is adjoined to. However, another possibility would be to claim that it is a base-generated PP. Our demonstration that this is not so is based on the binding conditions. In (45), it is shown that the object of $\overset{v}{s}el$ can serve as an antecedent for a lexical anaphor:

- (45) re'iyat 'acma $\overset{v}{s}el$ ha-mora⁸
 view herself of the-teacher
 'the teacher's view of herself'

Recall that we argued that (44) is grammatical due to the fact that \bar{N}_2 , in the structure in (43), c-commands \bar{N}_3 . In order to account for (45), we have to assume that \bar{N}_3 also c-commands \bar{N}_2 . Note, however, that if the $\overset{v}{s}el$ phrase were a PP, its object could not c-command \bar{N}_2 . Such a c-command relationship would violate the definition in (42) above. Indeed, objects of genuine PP's cannot c-command \bar{N}_2 in a similar structural configuration, as demonstrated by the sentences in (46) and the diagram in (47):

- (46)a. xašivat ha-mora 'al 'acma
 thinking the-teacher about herself
 'the teacher's thinking about herself'
- b. *xašivat 'acma 'al ha-mora
 thinking herself about the-teacher

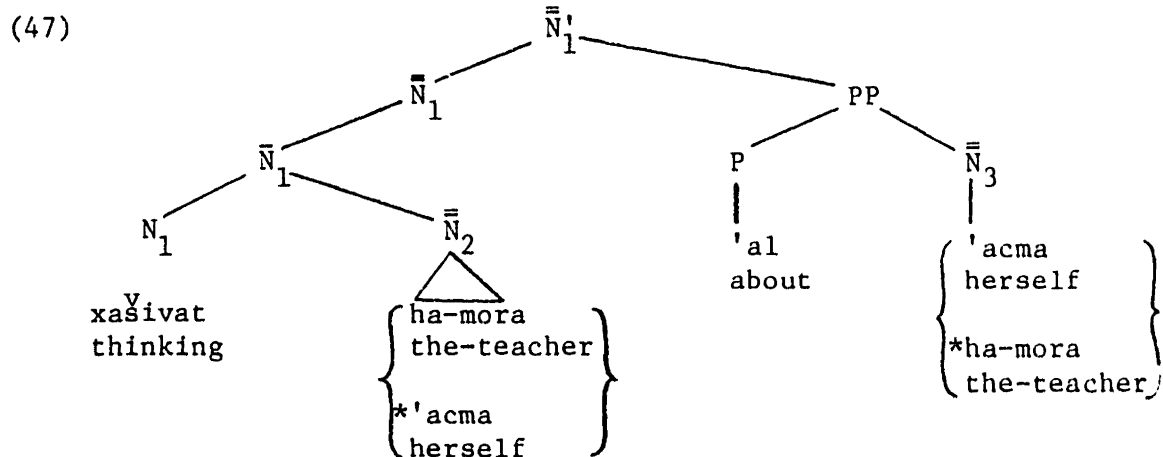

This contrast between the behaviour of genuine PP's and $\underline{\text{sel}}^{\text{v}}$ phrases can be readily explained if we assume that while true PP's adjoined to construct states have the structure in (47), in which no c-command relationship holds between \bar{N}_3 and \bar{N}_2 , $\underline{\text{sel}}^{\text{v}}$ phrases are not true PP's: they are NP's to which dummy Case marker $\underline{\text{sel}}^{\text{v}}$ has been adjoined at a level irrelevant for the binding conditions.

We thus conclude that the structure in (28) above is indeed the structure of clitic-doubling constructions. Our proof consisted of two stages: first it was shown that the clitic and the complement of $\underline{\text{sel}}^{\text{v}}$ are obligatorily coindexed, a condition which does not hold for lexical complements of the construct state and for the object of $\underline{\text{sel}}^{\text{v}}$ in equivalent configurations. It was further shown that the impossibility of coindexation between the complement of the construct state and the object of $\underline{\text{sel}}^{\text{v}}$ follows directly from the binding conditions. Since the relationship between the clitic and the coindexed NP is not sensitive to the binding conditions, we concluded that the clitic cannot possibly occupy an argument position. Thus we returned to our

assumption that it is a feature on the head noun.

The second stage of the proof consisted of showing that \bar{S} el phrases demonstrate different behaviour from PP's with respect to the binding conditions. Whereas PP's demonstrate typical behaviour, preventing their objects from c-commanding argument positions outside the PP, the objects of \bar{S} el phrases behave as bare NP's, thus entering into a binding relationship with elements which share the same governing category -- in this case, the higher \bar{N} . Thus we concluded that at the level in which the binding conditions apply, namely S-structure, \bar{S} el is not present: it is inserted later, for purposes of Case assignment, and its insertion does not affect the output of rules which apply in the syntax, at S-structure or in logical form. (For a detailed discussion of \bar{S} el insertion as well as a conclusion with respect to the level at which it applies, see chapter 3, section 3 below).⁹

2.4. Coindexing and Government

In section 2.2 above we have shown that a relationship of obligatory coindexing holds between the clitic and the associated NP_i in clitic-doubling constructions. Is this obligatory coindexing subject to any conditions? Consider the following sentences:

(48) misgeret tmunot ha-yalda \bar{S} el ha-mora
 frame pictures the-girl of the-teacher

(48) (a regular construct state formation without clitic or doubling, combined with a \bar{S} el phrase) permits the following bracketings:

(49)a. [[frame [pictures [the girl]]] of the teacher]
 'the teacher's frame of the pictures of the girl'

- b. [frame [[pictures [the girl]] of the teacher]]
 'the frame of the girl's pictures of the teacher'
- c. [frame [pictures [[the girl] of the teacher]]]
 'the frame of the pictures of the teacher's daughter'

Now compare the corresponding sentence with a clitic (and coindexing):

(50) misgeret tmunote-ha_i ^vsel ha-mora_i
 frame pictures-her of the-teacher

Theoretically, the same range of bracketing should be possible for (50) if we ensure the coindexing of the clitic and the complement of the vsel phrase. Note, however, what happens in (51), which is the list of possible bracketings for (50):

- (51)a. *[[frame [pictures-her [∅]]] of the teacher]
 'the teacher's pictures frame'
- b. [frame [[pictures-her [∅]] of the teacher]]
 'the frame of the teacher's pictures'
- c. [frame [pictures-her [[∅] of the teacher]]]
 'the frame of the teacher's pictures'

Interpretation (a), (which is definitely logically possible) is excluded. Interpretations (b-c) are clearly equivalent, in spite of the different structure.

Let us first consider why (a) is impossible. (51)a would have the structure in (52):

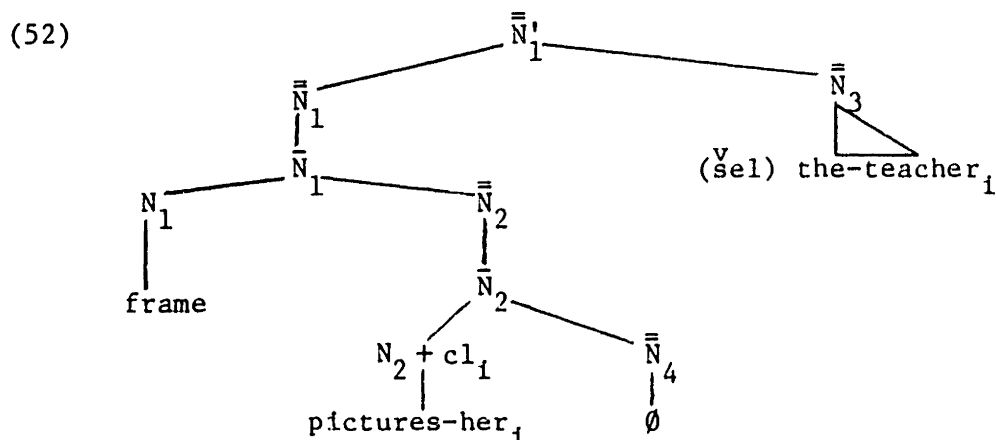

We would like to argue that the reason (52) is an ungrammatical construction is because the clitic on N_2 does not govern N_3 which is coindexed with it. In this we will be adopting the definition of government suggested in Chomsky (1981) and given in (59):

(53) Government (definition)

In the configuration [... β ... α ... β ...] α can be said to govern β iff:

- i. $\alpha = X^\circ$
- ii. where ϕ is a maximal projection, if ϕ dominates β then ϕ dominates α
- iii. α c-commands β

(Recall that we are assuming a revised definition of c-command, as given in (42) above).

Note that assuming that the clitic in the complex $N_2 + cl_1$ in (52) is a feature on the head N_2 will immediately lead to the conclusion that, since N_2 does not govern \bar{N}_3 , the clitic which is coindexed with \bar{N}_3 does not govern it either.

Now consider (54), which is the structure corresponding to (51) b above:

(54)

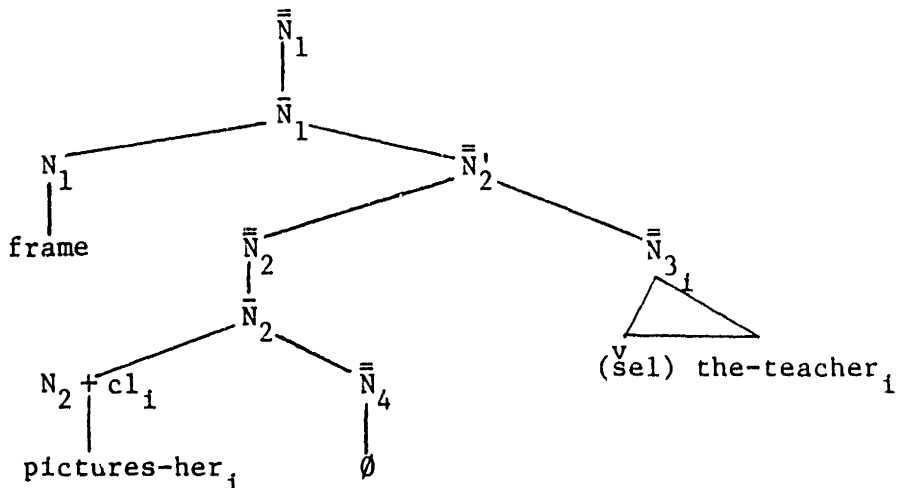

In this case the clitic does govern the coindexed argument. Thus coindexing is possible. Now, as a last point, consider the structure of (51)c:

(55)

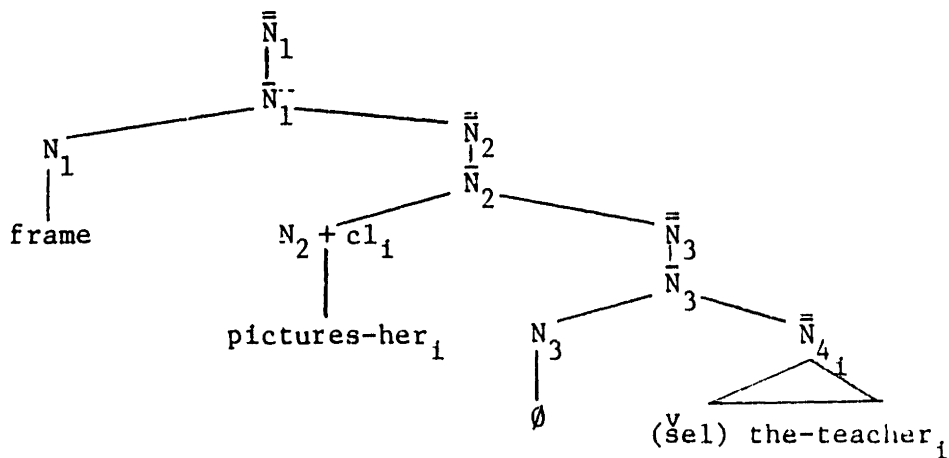

Again, \underline{cl}_i governs the coindexed argument.

Let us now turn to the node in (52), (54) and (55) which is marked as \emptyset . What is the status of this node? Recall that we are assuming the Complement Matching Requirement (see (5) above). Following this requirement, an element and its complement cannot contain conflicting indices. Now recall that the domain of complementation is that of

government. Thus the requirement that the clitic in (54) and (55) govern the complement l.P position with which it is coindexed follows immediately from the fact that the doubled NP is the complement of the head of the construct state. However, if the complementation requirements are met by the doubled NP, it is clear that the node \emptyset in (52), (54) and (55) is not assigned any index.

Recall that we assume that the following principle holds in the grammar:

(56)a. The Empty Category Principle (ECP)

[e] must be properly governed

b. α properly governs β iff α governs β and:

i. α is $\pm N$, $\pm V$, or

ii. α is coindexed with β

Following Kayne (1980) we will assume that ECP holds in LF. Furthermore, as indicated by the ungrammaticality of (57), nouns in Modern Hebrew are not proper governors:

(57) *mi ra'ita 'et beit [e]
 who saw-you acc house
 'whose house did you see?'

(We will return to this matter in great detail in sections 3 and 4 below. For our present purposes, it will suffice to claim that nouns in Hebrew are governors but not proper governors; hence (57) is ruled out as a violation of the ECP).

Now consider again the \emptyset node in (52), (54) and (55). Clearly, this node cannot be [e]. Since nouns in Hebrew are not proper governors,

it cannot be properly governed by the head noun. Furthermore, it cannot be properly governed by the clitic, since it is not coindexed with it. On the other hand, it cannot be PRO either. PRO is the pronominal form which is not realized phonologically and which cannot be governed. The \emptyset position in (52), (54) and (55) is governed by the head noun. We thus have a position which is not Case marked, which bears no referential index, which is governed but which is not properly governed.

Let us in fact assume that the node in question (\bar{N}_4 in (52), (54) and N_3 in (55)) simply does not exist. In other words, let us assume that complementation requirements can be met whenever the complement is governed by the head of the construct state and that the precise position of the complement in the tree is irrelevant, as long as this position is governed. Note that the phrase-structure rules can still generate the nodes dominated by \emptyset , since base rules are optional. However, nothing can appear in this position: lexical NP will not be assigned Case, PRO will be governed and [e] will not be properly governed. Thus if the node is generated, every possible derivation will be ruled out.¹⁰

Now let us turn back to the structures in (52), (54) and (55): in (52) the existence or the non existence of \bar{N}_4 is irrelevant: in any configuration, \bar{N}_3 is not governed by N_2 and hence it cannot be perceived as its complement. Thus the sentence is ruled out.¹¹ In (54), on the other hand, the derivation in which \bar{N}_4 is generated is ungrammatical, since no element can appear in this position. However, if the position is not generated the sentence is grammatical: \bar{N}_3 is

governed by N_2 and hence it can be interpreted as its complement.

Let us now consider (55): if N_3 is generated, the sentence is ruled out, since no element can appear in this position. If, on the other hand, N_3 is not generated, the \bar{N}_3 is deprived of its head: it is a genuinely 'headless' phrase. Clearly, the latter situation is ruled out by independent considerations related to \bar{X} theory. Hence, (55) is an impossible derivation, unless \bar{N}_4 is directly attached to \bar{N}_2 , resulting in a structure that is virtually identical to that of (54), as is shown by (58):

(58)

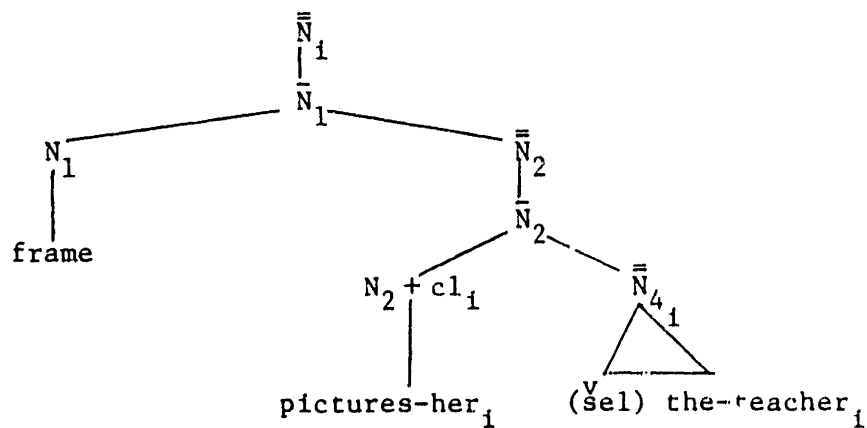

Deriving in this fashion the identity of structure between (54) and (55), and thus the identity of meaning, supplies further evidence that the clitic should be viewed as a feature on the head, rather than as an argument filling an argument position. If one wished to argue for the latter analysis, one would have to argue that the structures of (51)b and (51)c are as in (59)a and (59)b, respectively:

(59)a.

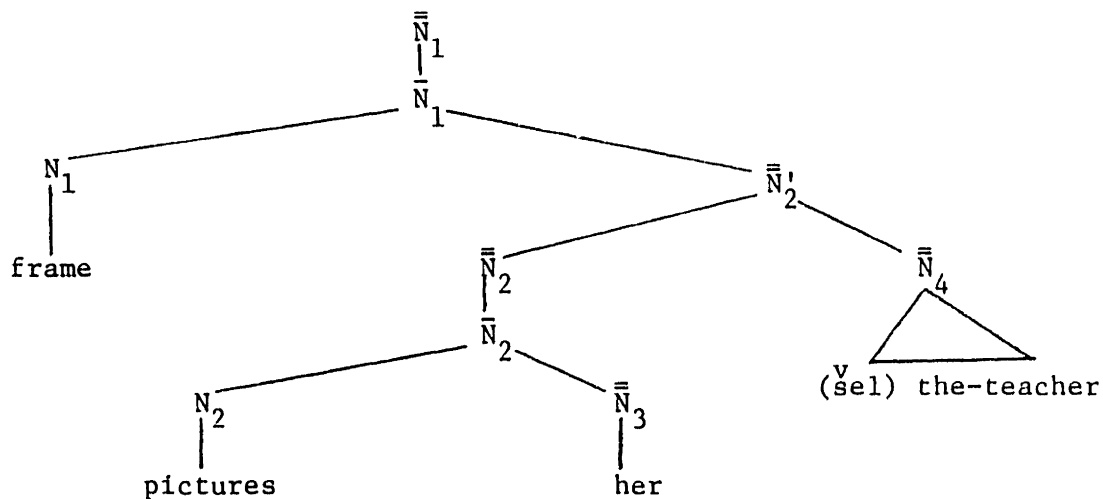

(59)b.

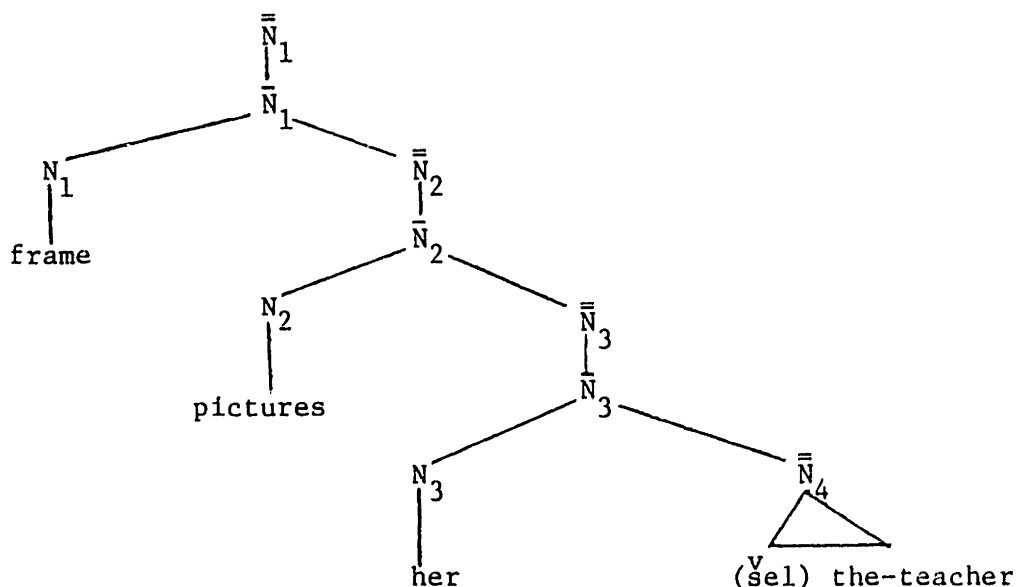

Proponents of this analysis would then have to explain the unavailability of an interpretation corresponding to (59)b and to (51)c above, although given the assumption that the clitic occupies an argument position, (59)b is a possible structure. The analysis which holds that the clitic is not an argument in an argument position, but rather is a feature on the head, and which holds that the \bar{v} sel phrase satisfies complementation requirements thus accounts satisfactorily for the unavailability of a

third reading.

Let us summarize our conclusions so far:

1. Clitics are generated as features on the head of their phrase. They are not filling the argument position which is the complement of this head. This position is independently generated and can be independently filled if a Case-assigning device is available. Clitic-doubling constructions thus have the structure in (60):

(60).

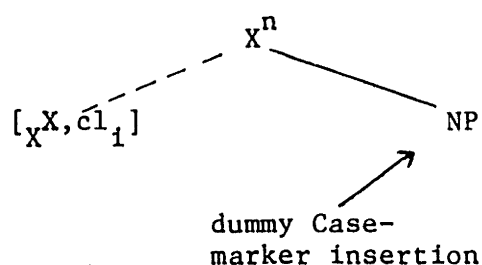

2. The coindexing of the clitic and the argument NP is obligatory and subject to the government relationship between the clitic and the argument with which it is coindexed. Given our assumption that clitics are generated as features on the head of their phrase, both the coindexing requirement and the government requirement follow naturally from the Complement Matching Requirement, which prevents a head from containing a referential index which conflicts with that of its complements.
3. The genitive preposition sel is not available in clitic-doubling constructions in the base. Rather, it is inserted in the phonological component; thus the structure which it creates is irrelevant to the binding conditions: the NP's which participate in clitic-doubling constructions behave in all respects as bare NP's, and differ in this sense from NP's which are objects of base-generated prepositions.
4. The domain of complementation is the government-domain of the head.

Given this minimal restriction, the complement phrase can appear in any position which is governed by the head. Assuming the definition of c-command in (42) above, this means that they may appear at any level of projection of the head, including adjoined positions.

Note that the latter hypothesis would seem to be incompatible with our assumption that in the construct state (when no doubling occurs and when no \bar{V}_{sel} phrase is adjoined) the complement has to be attached at the \bar{N} level (see examples (10) - (12) above and related discussion), yielding the structure in (61):

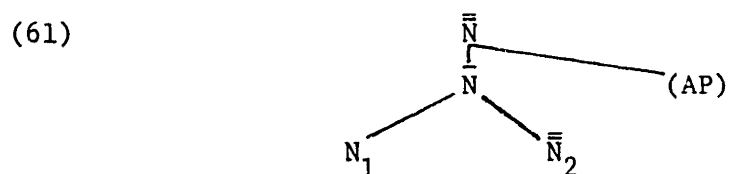

Recall, however, that we argued that strict adjacency between N_1 and \bar{N}_2 in (61) is required for the assignment of genitive Case. In contrast to (61), the structure in (54) above crucially involved the insertion of \bar{V}_{sel} , thus making strict adjacency unnecessary. Thus the value of X^n in (60) can be either \bar{X} , \bar{X} , or \bar{X}' (\bar{X}' representing an adjoined structure).

Let us now return to examples (32)a and (33) above, which were cited as possible counterexamples to our claim that the structure of clitic-doubling constructions is as in (60). We repeat them here as (62)a-b:

- (62)a. beit-a_i ha-yafe \bar{V}_{sel} ha-mora_i
 house-her the-beautiful of the-teacher
 'the beautiful house of the teacher'

- b. beit-a_i ha-yafe ve-ha-meruxak min ha-'ir $\overset{V}{\text{sel}}$
 house-her the-beautiful and-the-far from the-city of
 ha-mora_i
 the-teacher
 'the teacher's house which is beautiful and which is far from
 the city'

Recall that these phrases were potential counterexamples, since they indicated that intervening material can appear between the head+clitic combination and the complement argument in structures such as (60). In regular construct-state formations, such as (7), where no clitic appears, such intervening material is not possible, as shown by (63):

- (63) * beit yafe ha-mora
 house beautiful the-teacher
 'the teacher's beautiful house'

At this stage of the analysis, it is clear that the ungrammaticality of (62)a-b, as opposed to the ungrammaticality of (63), does not present any problem: we derived the ungrammaticality of (63) from the fact that strict adjacency is required in order to assign Case to ha-mora 'the teacher' in (63). Since there is no such strict adjacency in (63), the sentence is ruled out. On the other hand, we argued that -- where strict adjacency is not required, in the cases where the NP is assigned Case by $\overset{V}{\text{sel}}$ -- the complement node can be adjoined to any expansion of N. Thus we expect AP to be impossible in regular, non-doubled construct states, but we expect its occurrence to be entirely grammatical when $\overset{V}{\text{sel}}$ is present. Thus the structure of the grammatical sentence (62)a is as in (62)c:

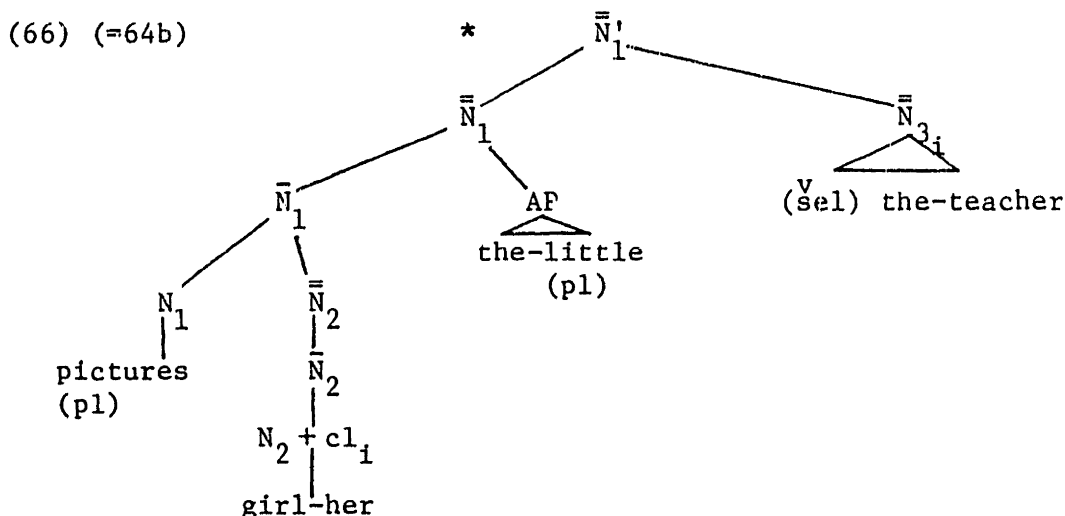

Note that the gender and number markers on the adjectives force us to argue for the structure in (65) for (64)a, since in that case the AP clearly modified yalda 'girl'. For the same reasons, the AP in (66) has to be generated adjoined to \bar{N}_1 , since it modifies tmunot 'pictures'. Note that, as a result of this configuration, the clitic governs the coindexed \bar{N}_3 in (65); hence the corresponding sentence, (64)a, is grammatical. In (66), on the other hand, such a government relation does not hold, and hence (64)b is ungrammatical.¹²

2.5. Three Genitive Constructions in Modern Hebrew

Recall that in the derivation of (54) and (55) we invoked the Complement Matching Requirement, along with the assumption that complementation requirements can be met by any NP which is governed by the head, quite independent from the position of this NP in the tree. These assumptions have some interesting consequences. We can now reduce all the genitive constructions in Hebrew to the structure in (60). In essence, then, we claim that the sentences in (67)a-c all have the structure in (60) (assuming that insertion of the dummy Case marker

is optional):

- (67)a. *beit ha-mora*
house the-teacher
- b. *beit-a_i ^vsel ha-mora_i*
house-her of the-teacher
- c. *ha-bayit ^vsel ha-mora*
the-house_a of the-teacher

The structure of (67)a-c is illustrated by (68)a-c, respectively:

(68)a. (= (67)a)

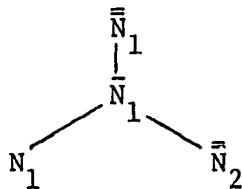

In (68)a, $\bar{\bar{N}}_2$ has to be generated under \bar{N}_1 , due to the strict adjacency principle. However, due to the availability of $\underline{\text{sel}}$ insertion, the strict adjacency principle does not hold in (67)b-c:

(68)b. (= (67)b)

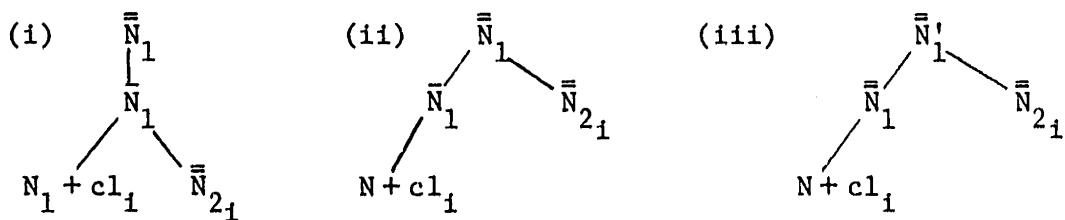

As demonstrated by (68)b, (67)b is structurally ambiguous. This situation, however, is irrelevant, since all the derivations satisfy the Complementation Matching Requirement. The same holds for (67)c, which is structurally ambiguous as well:

(68)c. (= (67)c)

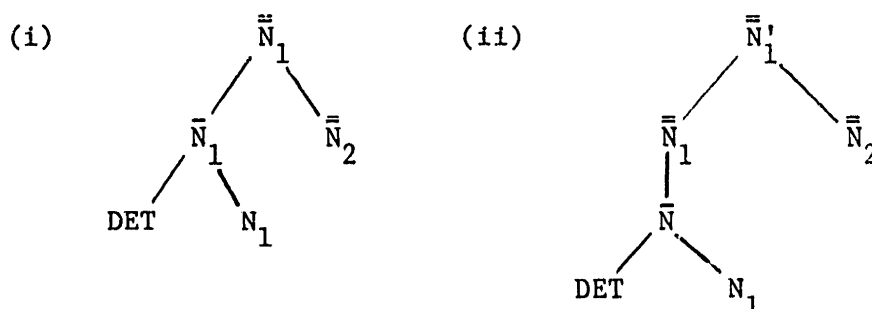

Note that (68)a-c are all manifestations of the structure in (60), in that in all of them, the complement of the head is governed by some expansion of N: \bar{N} , \bar{N} or \bar{N}' . Only one of these constructions is limited; in the construct state proper, the complement can only be generated under \bar{N} , as in (68). This limitation, however, has an independent explanation. It derives from the strict adjacency principle for genitive Case assignment. Note that, although we now argue that (67)b and (67)c are manifestations of the same structure, we avoid the pitfalls of the attempt to collapse these structures that was briefly sketched above (see diagram (34) and related discussion). The earlier analysis was incapable of capturing the differences between the clitic-doubling constructions and the regular genitive constructions using \bar{S}_{el} . Within our analysis, however, these differences are captured by assuming that the clitic in clitic-doubling constructions is a feature on the head rather than an argument occupying an argument position.

A very simple rule will now account for the insertion of \bar{S}_{el} both in (68)b and in (68)c:

(69) $\underline{\text{sel}}^{\text{v}}$ Insertion (SI^{v}) -- applies in the phonological component¹³

$$\emptyset \longrightarrow \underline{\text{sel}}^{\text{v}} / [\text{NP}_i \dots \text{NP}_j]$$

With respect to (69), we make one auxiliary assumption: we assume that the Case features of $\underline{\text{sel}}^{\text{v}}$ have to be phonologically realized. This implies that $\underline{\text{sel}}^{\text{v}}$ has to have a phonologically realized object or an attached clitic. Thus if $\underline{\text{sel}}^{\text{v}}$ is inserted preceding an empty category it will obligatorily include a clitic.

Note that the rule of SI^{v} as formulated in (69) does not preclude the structure in (70), in which $\bar{\text{N}}_2$ is marked twice with genitive Case -- once by the head N_1 and once by the inserted preposition $\underline{\text{sel}}^{\text{v}}$:

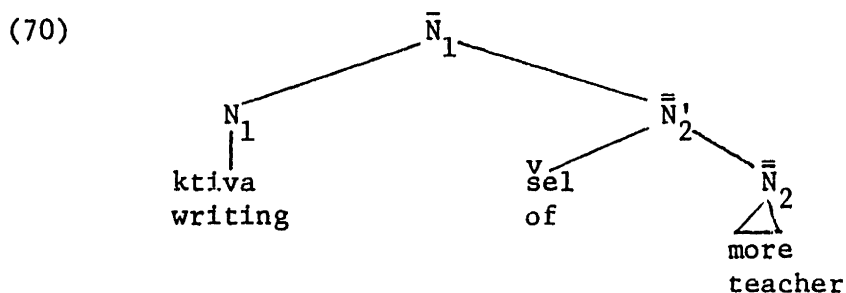

A phrase identical to the one in (70) can, however, be generated by the structure in (71):

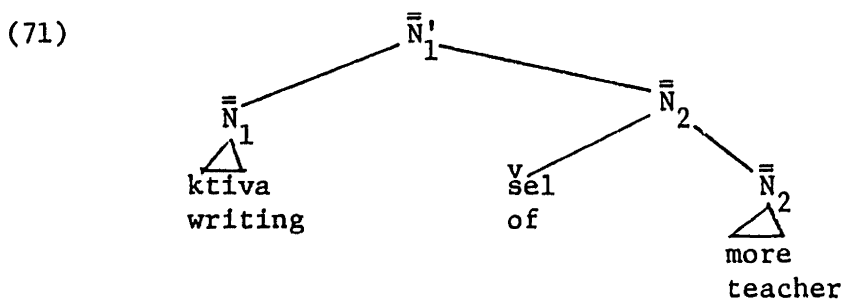

Both structures are, in fact, grammatical.

3. Extraction from Construct State Configurations

3.1 Introduction: Predictions

In section 2 above it was shown that the structure of clitic-doubling constructions at the level relevant for the operation of syntactic rules (prior to the phonological insertion of $\overset{v}{sel}$) is as in (72):

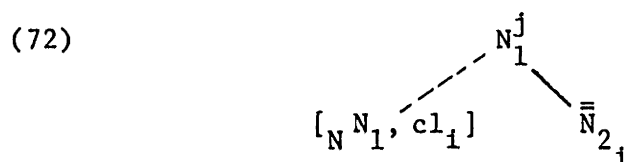

It was further shown that the relationship which holds between the clitic and the NP which is coindexed with it is that of government, and that the clitic constitutes part of the head and does not occupy an argument position. The insertion of $\overset{v}{sel}$ preceding \bar{N}_2 in (72) was explained as a device available in the phonological component to assign Case to \bar{N}_2 . The Case that usually would be assigned to that position is here spelled out as a clitic, and hence could not be assigned to \bar{N}_2 . Failure to insert $\overset{v}{sel}$, it was argued, would result in a violation of the Case filter.

Consider now sentences like (73)a-b:

- (73)a. *beit-o 'omed 'al ha-giv'a*
 house-his stands on the-hill
 'his house stands on the hill'
- b. *beit-o_i $\overset{v}{sel}$ ha-more₁ 'omed 'al ha-giv'a*
 house-his of the-teacher stands on the-hill
 'the teacher's house stands on the hill'

We have argued that the phrase *beit-o $\overset{v}{sel}$ ha-more* 'the teacher's house' has the structure in (72). However, what is the structure of the phrase

beit-o 'his house', as in (73)a? If we argue that the clitic in beit-o is a spell-out of Case features, as it is in (72) and (73)b, then the structure of beit-o is as in (74):

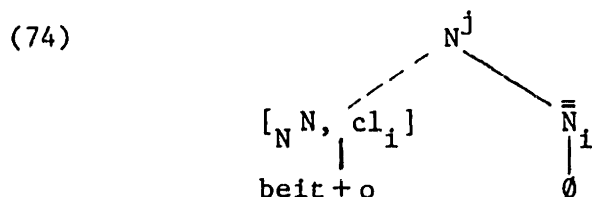

What is the status of \emptyset in (74)? Recall that when discussing the \emptyset node which appears in structures (52), (54) and (55) above, we concluded that the \emptyset node in these structures is simply not generated, and that complementation requirements are met by the governed, coindexed NP. In (74), however, there is no such governed, coindexed NP, apart from the \emptyset node itself.

Recall that we are assuming the ECP (as formulated in (56) above). Given this principle and the analysis of clitics proposed so far, we can now put our assumption that the clitics have to govern the coindexed position to a test. Three hypotheses (at least) are logically possible with respect to the \emptyset in (74):

Hypothesis A: \emptyset is in an ungoverned position. The process which allowed the clitic to absorb the Case of the head of its phrase also absorbed the government properties of the head. It follows that [e] cannot appear in this position, since government is a prerequisite to proper government, and a position which is not governed is, of course, also not properly governed. An [e] in this position would thus result in a violation of the ECP (see (56) above). Thus only PRO can appear

in this position. Note that according to this analysis, extraction from the NP_i position in (72) or in (74) is never possible: such extraction would leave behind an empty category [e] that could not be properly governed, thus violating the ECP. (This analysis is proposed by Jaeggli, 1980, for River Plate Spanish). Hypothesis A is illustrated in (75)a-b:

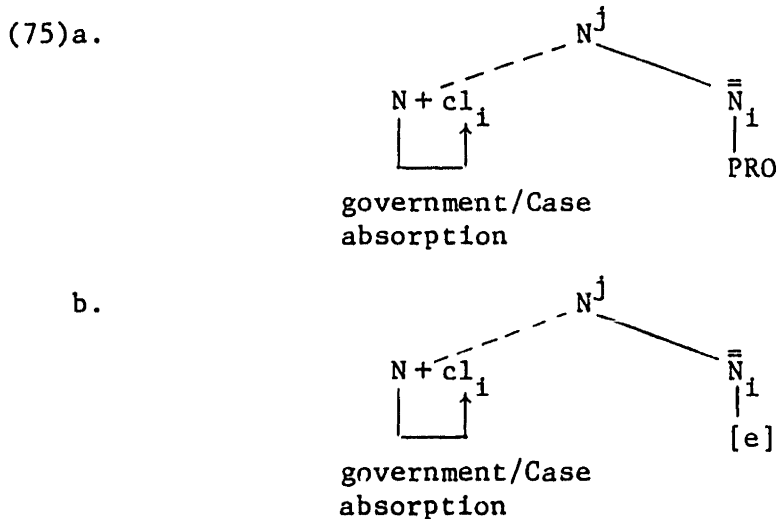

In (75)b, [e] is not properly governed (in fact, it is not governed at all), since the government property was absorbed by the coindexed clitic. Thus, the construction is ruled out as a violation of the ECP.

Note that hypothesis A is incompatible with our conclusion that the clitic must govern the coindexed NP position: if the clitic did govern the coindexed position, and we were to assume hypothesis A, then, given the definition of proper government in (56) above, a special mechanism would be required to block proper government by the coindexed, governing clitic in (75).

Proponents of hypothesis A would thus have to argue that the structure of the N+cl combination is branching, as in (76) and for a stricter definition of c-command than the one we have been assuming:

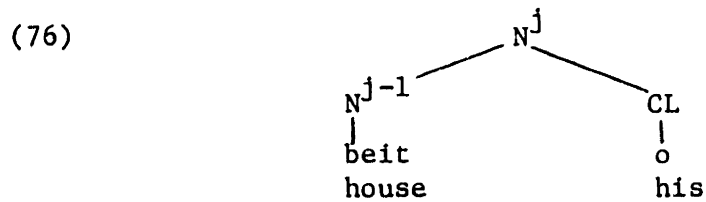

Some theoretical disadvantages of the structure in (76) were discussed in the introduction. Some others will be discussed in chapter 3 below. Empirically, the structure in (76) clearly does not enable us to state in a natural way the fact that the clitic has to govern the NP with which it is coindexed in clitic-doubling configurations. In fact, for supporters of structure (76) it is crucial to claim that no government relationship holds between the clitic and the coindexed NP, in order to block proper government in this position.

Yet another empirical problem of the structure in (75) and (76) is the fact that it makes a clearly wrong prediction with respect to extraction from clitic-doubling constructions: it predicts that extraction of NP_1 in (72) is impossible, which is incorrect. We shall return to the proof that this extraction is possible below.

Hypothesis B: The clitic in (74) absorbs only Case but not government. The \emptyset is thus governed and properly governed by the head N. It follows that PRO cannot appear there, since it would be governed in this position; [e], however, can appear there, and indeed it does. It follows from this analysis that extraction from this position is possible. These predictions made by hypothesis B are illustrated by (77)a-c:

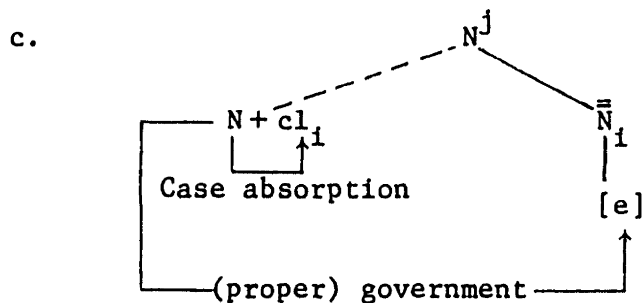
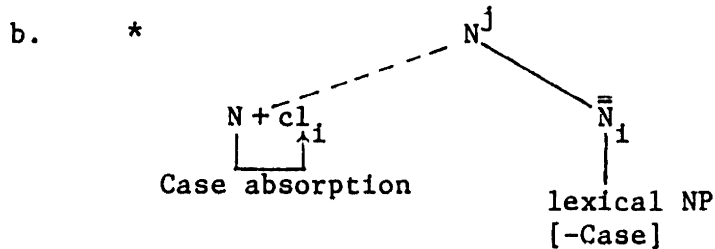
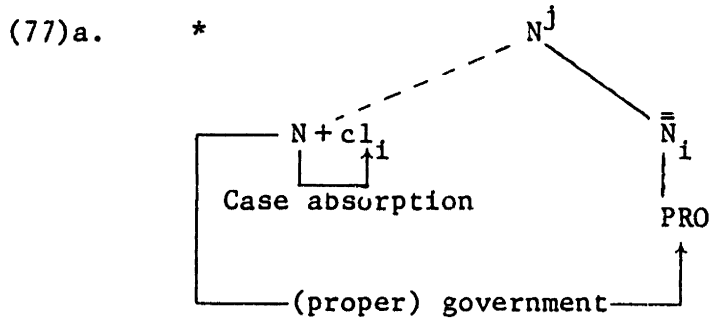

Unlike proponents of hypothesis A, proponents of B do not have to argue for a branching structure for the N+clitic combination. Thus they also do not confront the problem of accounting for the government relationship which determines the coindexing between the clitic and the double NP. Note further that hypothesis B correctly predicts that extraction from the coindexed NP is possible.

Note, however, that in (77)c[e] is in fact properly governed twice: assuming the definition of proper government in (56) above, there is no way to block proper government by the clitic in (77)c. On the other hand, there is some evidence that hypothesis B cannot be correct. This stems from the fact that lexical nouns in Modern Hebrew

are arguably not proper governors, and that, consequently, "noun stranding" is impossible:

- (78)a. pataxti 'et delet ha-kita
 opened-I acc door the-classroom
 'I opened the classroom door'
- b. *ma_i pataxti 'et delet [e]_i?
 what opened-I acc door
 'what did I open the door of?'
- c. 'et delet ma_i pataxti [e]_i?
 acc door what opened-I
 'the door of what did I open?'

The sentences in (78) thus motivate a slight change in the definition of proper government. The modified definition is given in (79):

- (79) α properly governs β iff α governs β and
 i. α is [+V], or
 ii. α is coindexed with β .¹⁴

It follows that hypothesis B has to be rejected. It crucially assumes that nouns are proper governors, which is incompatible with the ungrammaticality of (78)b.

Hypothesis C: \emptyset is properly governed by the governing coindexed clitic. Hence PRO cannot appear there; lexical NP cannot appear there; but [e] can. Extraction from this position is possible.

Note that the configurations which hypothesis C permits are essentially identical to those allowed by hypothesis B with one exception: in (77)a and (77)c it is not the head N which governs the NP_i position; rather it is the coindexed, governing clitic. Thus, this hypothesis

avoids hypothesis B's wrong predictions with respect to proper government by nouns in Modern Hebrew.

The argument in the following sections will consist of two major points:

In the remainder of section 3, it will be shown that extraction of NP₁ in structures such as (72) is indeed possible. The evidence will consist of an analysis of free relatives in Modern Hebrew. (See below, chapter 3, section 3, for direct evidence that extraction from clitic-doubling constructions is grammatical in Rumanian as well.)

In section 4, proper government by clitics will be argued for directly by adducing some evidence from movement in syntax and logical form in Modern Hebrew, thus showing clearly that clitics in configurations like (72) have to be allowed to properly govern the coindexed position.

3.2. Free Relatives in Modern Hebrew

Modern Hebrew allows for two relativization strategies, as observed in Hayoun (1973) and in Chomsky (1977): (1) a movement strategy, in which all the usual constraints on movement are obeyed (see (80)-(82)), and (2) a no-movement strategy using resumptive pronouns (resumptive clitics for PP's and NP's and free-standing pronouns for direct objects),¹⁵ where all the usual constraints can be violated,¹⁶ which is demonstrated in (83)-(85):

- (80)a. ha-'iš^v še-('oto_i) pagašti t_i
 the-man that-him_i met-I t_i
 'the man I met'
- b. *ha-'iša^v še-('ota_i) pagašti 'et ha-'iš_j^v še t_j ra'a t_i
 the-woman that-her_i met-I acc the-man_j that t_j saw t_i
 'the woman that I met the man who saw her'
 (Complex NP Constraint Violation; Ross, 1967)
- (81)a. ha-'iš^v še-'it-o_i rakadti t_i
 the-man that-with-him_i danced-I t_i
 'the man with whom I danced'
- b. *ha-'iša^v še-'it-a_j ra'iti 'et ha-'iš_i^v še-t_i rakad t_j
 the-woman that-with-her_j saw-I acc the-man_i that-t_i danced t_j
 (Complex NP Constraint Violation)
- (82)a. ha-'iš^v še-'et 'axot-o_i ra'iti t_i
 the-man that-acc sister-his_i saw-I t_i
 'the man whose sister I saw'
- b. *ha-'iš^v še-'et 'axot-o_i ra'iti 'et ha-kelev_j^v še t_j našax t_i
 the-man that-acc sister-his_i saw-I acc the dog_j that t_j bit t_i
 (Complex NP Constraint Violation)
- (83)a. ha-'iš^v še-ra'iti 'oto
 the-man that-saw-I him
- b. ha-'iš_i^v še-pagašti 'et ha-'iša_j^v še-t_j ra'ata 'oto_i
 the-man_i that-met-I acc the-woman_j that_j saw him_i
- (84)a. ha-'iš^v še-rakadti 'it-o
 the-man that-danced-I with-him
- b. ha-'iša^v še-pagašti 'et ha-'iš^v še-rakad 'it-a
 the-woman that-met-I acc the-man that-danced with-her
- (85)a. ha-'iš^v še-ra'iti 'et 'axot-o
 the-man that-saw-I acc sister-his
- b. ha-'iš_i^v še-ra'iti 'et ha-kelev^v še-'axot-o_i 'imca
 the-man that-saw-I acc the-dog that-sister-his adopted

Note that Modern Hebrew does not have a relative pronoun, and that the free-standing accusative pronoun 'oto is fronted and optionally deleted (as in (80)a). (See Borer, 1979, for a detailed discussion of the conditions under which 'oto deletes and for arguments that it is deleted from the COMP position.) When the relativized element is an object of a preposition or of a noun, pied piping is obligatory. The obligatoriness of pied piping in these cases would follow if we assume, as in Kayne (1980b), that prepositions as well as nouns are not proper governors in Modern Hebrew.¹⁷ Stranding prepositions or nouns would thus result in a violation of ECP ((56) above). Interestingly, these environments, namely following nouns and prepositions, are precisely the environments which allow for cliticization in Modern Hebrew. Modern Hebrew verbs (unlike those of earlier stages of Hebrew) no longer take clitics. Instead, they take the free-standing form 'oto. We will return to this point below.

Although both movement and non-movement strategies are available for relative clauses, only the movement strategy is possible in questions:

- (86)a. 'et mi ra'iti
acc who saw-I
'who did I see?'
b. *mi ra'iti 'oto
who saw-I him
- (87)a. 'im mi rakadti
with who danced-I
'with whom did I dance?'
b. *mi rakadti 'it-o?
who danced-I with-him
- (88)a. 'axot mi 'imca kelev
sister who adopted dog
'whose sister adopted a dog?'
b. *mi 'axot-o 'imca kelev
who sister-his adopted dog

As for free relatives, the situation is considerably more compli-

cated. At first glance, it appears that the same options are open for free relatives that are open for regular ones -- the movement strategy and the no-movement strategy (with resumptive elements). However, there are significant differences between free relatives and regular relatives which surface under closer investigation. First of all, the resumptive pronouns appear in free relatives only inside NP's and PP's, as in (89)a-b. It is precisely in these environment that the resumptive element is a clitic on the head of its phrase. In direct object position, where the resumptive element is an independent pronominal form, there is an obligatory gap:

- (89)a. ma ^Vše-hexlatnu 'al-av
 what that-decided-we on-it
 'whatever we decided on'
- b. mi ^Vše-'axot-o mazkira ba-memšala
 who that-sister-his secretary in-the-government
 'one whose sister is a secretary for the government'
- c. ma ^Vše-raciti (*'oto)
 what that-wanted-I (*it)
 'whatever I wanted'

Furtnermore, violations of the usual constraints are completely impossible in free relatives, regardless of the presence of resumptive clitics. Thus (90)a-b are ungrammatical (and compare with (84)b and (85)b):

- (90)a. *ma₁ ^Ve-pagaš^Vti 'et ha-'iš ^Vše-hexlit 'al-av₁ nimkar 'etmol
 what that-met-I acc the-man that-decided on-it sold yesterday
 'whatever I met the man who decided on it was sold yesterday'
- b. (*)keday le-hityaded 'im mi₁ ^Vše-'e'evod be-misrad ^Vše-'axoto₁
 worth to-befriend with who that-work-I in-office that-sister-his
 menahelet
 runs

'it is worth it to befriend a person whose sister runs an office in which I will work'

In view of (90)a-b, a natural assumption would be that free relatives are formed by movement and that the clitics in (90)a-b are not "real" resumptive pronouns. One could argue that they are the result of some trace-spelling rule (as suggested in Borer, 1979), or of a shadow-pronoun copying rule in the sense of Perlmutter (1972). Note, however, that this explanation leaves the asymmetry between questions and free relatives unexplained. If the clitics in (90)a-b are a result of a copying rule, why isn't a similar mechanism available to questions -- in other words, why are (87) and (88) ungrammatical?

We have an explanation for all these facts if we assume the following things:

1. The structure of both construct-state formations and PP's in Modern Hebrew is as in (91):

(91)

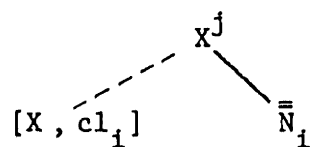

Recall that for construct formations we have independent evidence that this is indeed the correct structure. This evidence stems from clitic-doubling constructions. Although no such direct evidence is available for PP constructions, I will assume that they have exactly the same structure. This implies, in effect, that in PP's, as in the construct state, clitics are a spell-out of Case features as gender, number and person markers on the head itself, and that the subcategorized NP com-

plement is coindexed with the clitic and governed by it. The structure of (92) would thus be as in (93):

(92) 'it-o
with-him

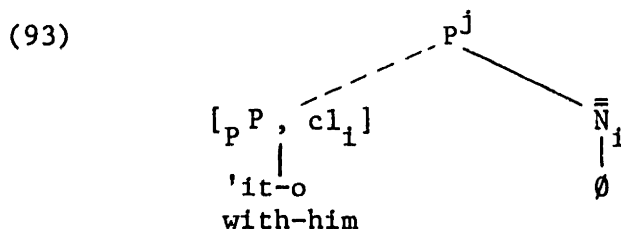

--whereas the structure of (94) would be as in (95):

(94) 'im Dan
with Dan

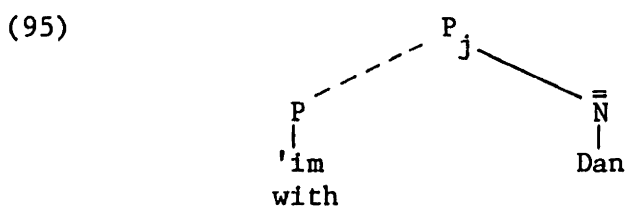

Unlike construct-state NP's, PP's do not have a "saving device" similar to sel that would enable the \bar{N} in (93) to surface alongside the clitic. The absorption of Case features, which surface as a clitic, thus excludes the surfacing of the \bar{N} complement itself.¹⁹

Note that we can now assume that the \bar{N} position in (93) is, in fact, the position from which extraction in free relatives takes place. Extraction from this position will leave a clitic behind, thus accounting for the apparent "resumptive clitic" in (89)a-b, in spite of the fact that extraction has taken place. Thus we can explain why, in spite of the availability of resumptive pronouns, constraints on movement cannot be violated. On the other hand, extraction from direct object

position, leaving a resumptive pronoun, is impossible. This follows immediately from the fact that verbs in Modern Hebrew no longer take clitics. The structure of VP in Modern Hebrew is thus as in (96):



Now consider the structures in (97)-(99), in which the pre-extraction configuration of (97)-(99) is illustrated (irrelevant details omitted):

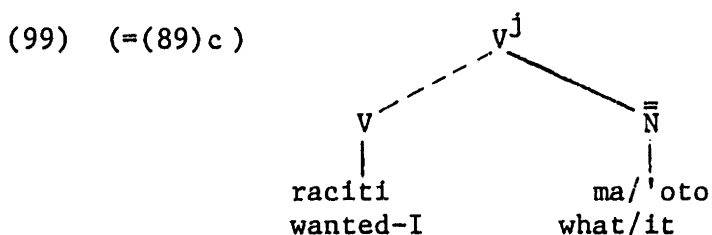
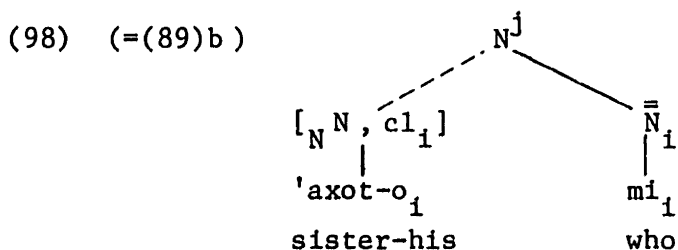
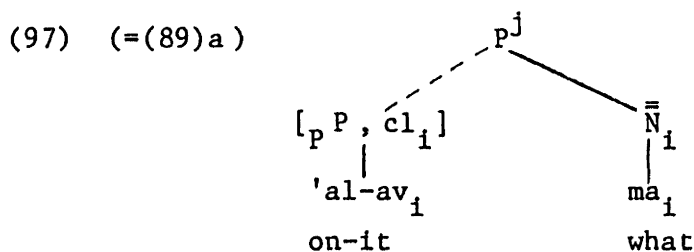

Whereas structures (97) and (98) have a position distinct from the resumptive clitic from which extraction can take place, (99) does not have such a position: both the WH word and the resumptive pronoun are generated under the same node, thus accounting for their complementary distribution.

Note that, although we have established the existence of an extraction site and explained the ungrammaticality of (89)c and (90)a-b, we still have to explain the ungrammaticality of the parallel questions, as in (87) and (88). To do so, we will assume the following:

2. Free relatives in Modern Hebrew possess a mechanism which enables WH words in COMP to receive Case from the matrix. (Such a mechanism is argued for in detail in Groos and van Riemsdijk, 1979.) We are now equipped with an appropriate mechanism to explain the difference between questions and free relatives. Note that since Case is absorbed by the clitics in structures such as (97) and (98), the WH word generated under the \bar{N} position will not have Case. Unless a special device is available to assign Case to it, it will be ruled out by the Case filter. Such a device is available to free relatives, but not to questions. It follows that when Case absorption takes place, only free relatives are grammatical. Questions are ruled out by the Case filter.

The derivation of (89)a, following our assumptions so far, would be roughly as in (100):

(100) X ... [\bar{S} [COMP ma_i] \bar{v} se [\bar{S} hexlatnu [$_{PP}$ 'al-av $_1$ t $_1$]]]²⁰
 Case assignment, where X has Case-assignment features

Let us now return to our point of departure. With respect to the identity of the \emptyset in structures such as (74) above, two hypotheses were contrasted: one claimed that \emptyset stands for PRO, and the other claimed that \emptyset stands for [e]. It was pointed out that the two hypotheses make different predictions with respect to extraction from the \bar{N}_1 position in (74). Whereas the PRO hypothesis predicts that extraction is impos-

sible, the [e] hypothesis predicts that it is possible. The data presented above indicate that we can account for certain rather interesting facts in Modern Hebrew if we assume that the \emptyset stands for [e]. The availability of extraction from this position enables us to explain the occurrence of apparent resumptive clitics inside free relatives, which differ in their characteristics from regular resumptive pronouns. It enables us to explain the impossibility of violating the constraints on movement despite the occurrence of such clitics. Finally, it provides an explanation of the fact that these clitics, although they appear in free relatives, do not appear in questions. Thus, we conclude that extraction from the \bar{N}_1 position in (74) is indeed possible, thus again supporting the [e] hypothesis over the PRO hypothesis.

3.3. $\bar{s}el$ Insertion Revisited

In analyzing the difference between questions and free relatives in Modern Hebrew we crucially relied on the fact that the WH element which is fronted -- both in questions and in free relatives -- is not Case-marked when extraction takes place from structures such as (97) and (98). Note, however, that there could be a way around this "caselessness" at least for (98) if $\bar{s}el$, the genitive preposition inserted to assign Case to \bar{N}_1 in (98), is present. In this case the WH element would have Case, and in precisely these cases we would expect questions to be grammatical. (In fact, in these cases we would expect only questions to be grammatical. Free relatives would be ruled out, since the fronting of $\bar{s}el$ would yield genitive Case marking on the head, which we would expect to be grammatical only when the free relative as a con-

stituent appears in a genitive position with respect to the matrix. This is due to the "matching effect" requirement (in the sense of Grimshaw, 1977, and Bresnan and Grimshaw, 1978).²¹ Nevertheless, (101) is ungrammatical just as (96)b is:

- (101) * \check{S}_{el} mi_i 'axot- o_i [e] $_i$ 'imca kelev?
of whom sister-his adopted dog
'whose sister adopted a dog?

What is the reason for the ungrammaticality of (101)? Why can't the \check{S}_{el} phrase be fronted in its entirety? Note that in this respect \check{S}_{el} phrases behave differently from PP's: the latter can be extracted from NP's:²²

- (102)a. Itamar nitbakeš \check{V} le-hachir be-'eize 'irgunim hu
Itamar was-requested to-declare in-which organizations he
haya xaver [pp^e]
was member
- b. *Itamar nitbakeš \check{V} le-hachir \check{S}_{el} 'eize 'anašim hu
Itamar was-requested to-declare of which people he
haya xaver [\check{S}_{el} phrase e]
was friend
- (103)a. \check{S}_{al} 'eize mešorer kaniti sefer [pp^e] ?
about which poet bought-I book
- b. * \check{S}_{el} 'eize mešorer kaniti sefer [\check{S}_{el} phrase e] ?
of which poet bought-I book

We would like to claim that the impossibility of extracting \check{S}_{el} along with the fronted WH element follows from the fact that \check{S}_{el} simply does not exist at that level of the grammar at which extraction takes place -- namely, syntax. Recall that we already argued that \check{S}_{el} phrases

do not behave as branching structures with respect to the binding conditions (section 2.3 above); rather, they behave as bare NP's. This presents us with additional evidence that $\overset{V}{s}el$ is not available before the phonological component: it cannot serve as an input to syntactic rules.

Let us now repeat the rule for $\overset{V}{s}el$ insertion ($\overset{V}{S}I$) (see (69) above):

- (104) $\overset{V}{s}el$ Insertion ($\overset{V}{S}I$) -- applies in the phonological component
- $$\emptyset \longrightarrow \overset{V}{s}el / [_{NP_i} \dots \text{---} NP_j]$$

If we assume (104) to be a rule of phonology (but see chapter 3, section 3.3. for further discussion), sensitive to local context, it is clear that an extracted NP no longer satisfies the environment for $\overset{V}{s}el$ insertion. Thus, although $\overset{V}{s}el$ insertion is available as a 'rescuing device' for clitic-doubling constructions, it is no longer available for the fronted WH element in free relatives or in questions, since the extracted NP_j does not satisfy the environment specified in (104). Note that $\overset{V}{s}el$ insertion can still apply preceding an empty category dominated by NP_j in (104): it can apply in the post extraction structure. Given that the Case features of $\overset{V}{s}el$ have to be phonetically realized, this would yield a $\overset{V}{s}el$ +clitic combination and indeed, such $\overset{V}{s}el$ +clitic combinations are possible in free relatives ((105)a), but in questions, their availability would not change the fact that the fronted WH element is caseless. Hence (105)b is ungrammatical regardless of the insertion

of $\overset{v}{s}el$:

- (105)a. mi_i $\overset{v}{s}e$ -beit- o_i $\overset{v}{s}el$ - o_i [e] $_i$ nisraf
 who that-house-his of-his burned
 'the one whose house was burned'
- b. * mi_i beit- o_i $\overset{v}{s}el$ - o_i [e] $_i$ nisraf?
 who house-his of-his burned
 'whose house was burned?'

For detailed discussion of the clitic on $\overset{v}{s}el$ see chapter 3, section 3.3.1.

4. Proper Government by Coindexed Clitic

4.1 Predictions

In section 3 above it was established that, in configurations like (106) below, \emptyset can stand for [e], since extraction is possible from this position. The availability of extraction from this position indicates clearly that this position is properly governed. If this were not the case, extraction from this position would inevitably lead to a violation of the Empty Category Principle (see (56) above). Since proper government entails government, it follows that, in fact, whenever no phonologically realized element appears dominated by \bar{N}_i , this node dominates [e] rather than PRO; PRO in this position would be governed and hence ruled out. \emptyset , then, not only can stand for [e], it must stand for [e], since it cannot stand for anything else:

(106)

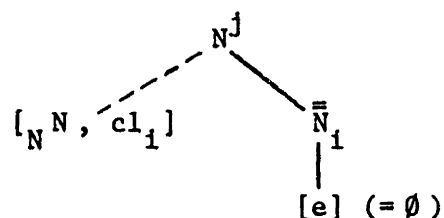

What properly governs [e] in this position, in accordance with the Empty Category Principle? In section 3.1 above it was shown that nouns in Modern Hebrew, like prepositions, cannot function as proper governors. (See examples (78)a-c above and related discussion.) Thus, the proper government of [e] in (106) cannot fall under clause (i) of the definition of proper government in (79). In section 2 above we argued that, in (106) and similar structures, the clitic is a feature on the head noun and that, as such, it governs \bar{N}_1 . Recall that clause (ii) of the definition of proper government in (79) allowed for an element to be properly governed if it is governed by a coindexed element. Since the clitic both governs and is coindexed with \bar{N}_1 , it is a plausible assumption that the clitic does indeed properly govern [e] in this position. This is compatible with hypothesis C, which was illustrated in section 3.1 above.²³

In fact, Modern Hebrew offers some direct evidence that in configurations like (106) the clitic does indeed properly govern [e]. This evidence comes from movement both in syntax and in LF.

4.2 Two Clitic Configurations

Consider again the construct-state constructions illustrated in section 2 above. An interesting property of the \bar{N} complement in these constructions is that it is perfectly ambiguous between two possible interpretations: if the head noun is a derived nominal which can take both object and subject, the complement \bar{N} can be construed either as its subject or as its object. Thus the phrases in (107)a-b have identical structures -- that represented in (107)c:

- (107)a. ktivat Itamar
writing Itamar
'Itamar's writing' |||
- b. ktivat ha-ma'amar
writing the-article
'the writing of the article'
- c.
-
- ```

 Nj
 / \
 N N̄
 | |
ktivat { Itamar
writing { ha-ma'amar
 }
 the article

```

Example (108), with the structure in (109), is entirely ambiguous:

- (108) ktivat-o  
writing-his/its  
{ 'his writing' }  
{ 'its writing' }

- (109)
- 
- ```

      Nj
     /  \
  N+cli  N̄i
   |       |
ktivat-o  [e]
writing-his/it
  
```

Clitic doubling is equally possible with both interpretations:

- (110)a. ktivat-o ^vsel Itamar
writing-his of Itamar
- b. ktivat-o ^vsel ha-ma'amar
writing-it of the-article

Note, however, that if one of the arguments is generated as the complement of the head, it is assigned genitive Case features; consequently, the other argument cannot be assigned Case. It can, however, be rescued either if ^vsel is inserted ((111)b-c) or if the accusative

dummy Case marker 'et is available to assign Case to the understood object, as in (111)a:

- (111)a. ktivat Dan 'et ha-ma'amar
 writing Dan acc the-article
 'Dan's writing of the article'
- b. ktivat ha-ma'amarim sel Dan
 writing the-articles of Dan
 'Dan's writing of the articles'
- c. ?ktivat Dan sel ha-ma'amar²⁴
 writing Dan of the-article
 'Dan's writing of the article'

We will assume the structure of (111)a to be as in (112):²⁵

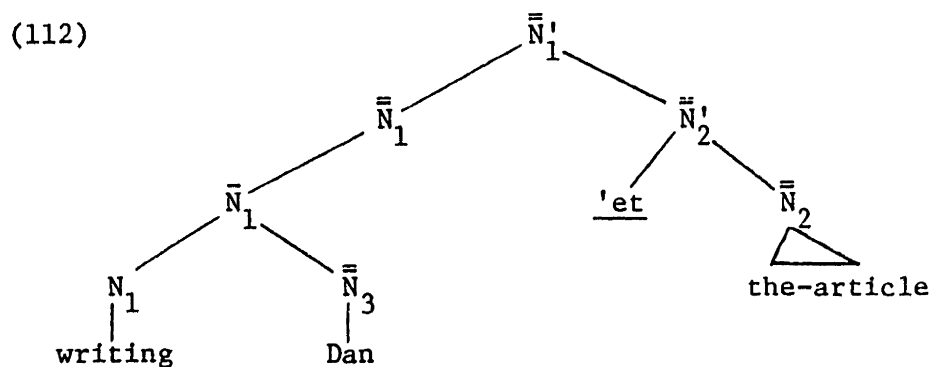

(The structures of (111)b-c are essentially identical, with sel substituting for 'et. Note that the structure we proposed for the construct-state constructions (as in (72) above) generates (112) in a straightforward fashion.)

In the structure corresponding to (112), doubling is possible, as is illustrated by (113):

- (113) ktivat-o₁ sel Dan₁ 'et ha-ma'amar
 writing-his of Dan acc the-article
 'Dan's writing of the article'

Again note that (113) is generated by our construct-state structure without any complications.

In the structure corresponding to (112), the subject in \bar{N}_3 can be cliticized. The resulting situation is given in (114):

- (114) ktivat-o_i 'et ha-ma'amar_j hirgiza 'et Dan
 writing-his acc the-article annoyed acc Dan
 'his writing of the article annoyed Dan'

The structure of (114) is as in (115):

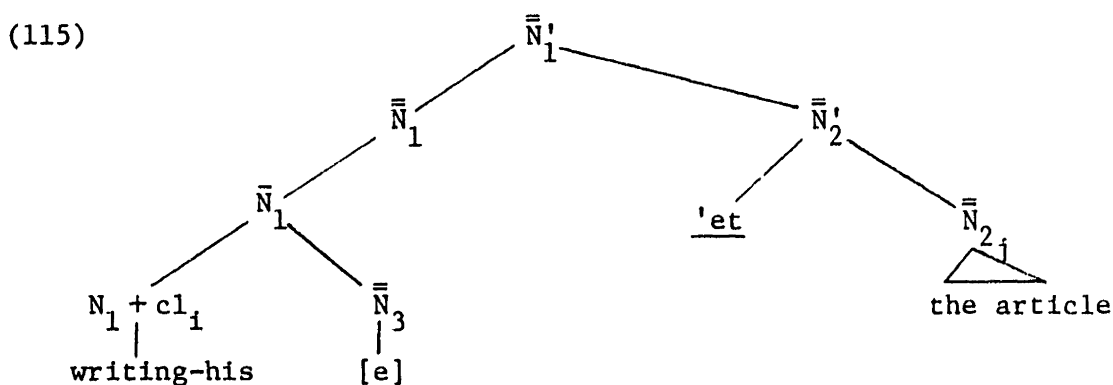

A few things should be noted with respect to (115). The Complement Matching Requirement is met by \bar{N}_3 ; nevertheless, the relationship which holds between the clitic_i and \bar{N}_2 is that of government (although not of coindexing).²⁶

One could argue that since the accusative marker 'et is available in Modern Hebrew anyway, as a base-generated marker there is no evidence that, in constructions like (115), it is inserted for Case purposes. Recall that above we have presented two arguments that \bar{v}_{sel} is inserted in the phonological component and is not available in the syntax or at S-structure: first, we showed that \bar{v}_{sel} phrases behave as "flat" structures. They are NP's with respect to the binding conditions in

sentences such as (116) (see also example (45) and related discussion in section 2.3 above):

- (116) re'iyat 'acma ^vsel ha-mora
 view herself of the-teacher
 'the teacher's view of herself'

Second, we showed that ^vsel does not participate in syntactic movement rules: when a WH element is fronted from a clitic-doubling construction it is not fronted with ^vsel (see section 3.3 above):

- (117) *^vsel mi_i 'axot-o_i 'imca kelev?
 of whom sister-his adopted dog

Both these arguments fail to extend to 'et. First, 'et does not behave as a "flat" NP with respect to the binding conditions:

- (118) *re'iyat 'acma 'et ha-mora
 view herself acc the-teacher
 'the teacher's view of herself'

Second, it clearly can be fronted with WH elements:

- (119) 'et mi ra'iti?
 acc who saw-I

Thus, it seems, no argument can be constructed to show that 'et is inserted in the phonological component. In fact, we would like to argue that 'et is base-generated and that it is adjoined to its phrase, as illustrated by (120):²⁷

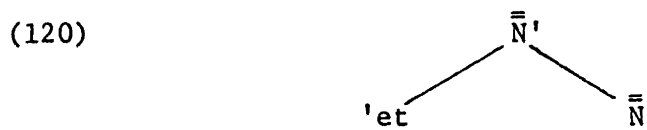

The structure in (120) is the input both to the binding conditions and to movement rules. The latter will move the full $\bar{\bar{N}}'$ constituent, yielding (119). The binding conditions, in turn, will treat the structure in (120) as branching and will block $\bar{\bar{N}}$ from functioning as an antecedent for 'herself' in (118).²⁸

There is, however, strong evidence that 'et in the environment of (112) and (115) is obligatory rather than optional, as it is elsewhere. Thus consider the following phrases:

- (121)a. ('et) ma Eliševa^v ra'ata?
 acc what Eliševa^v saw-she
 'what did Eliševa see?'
- b. Eliševa^v ra'ata (*'et) kof
 Eliševa^v saw acc monkey
 'Eliševa saw a monkey'
- c. Eliševa^v ra'ata *('et) ha-kof
 Eliševa^v saw acc the-monkey

The generalization characterizing (121)a-c is that the accusative marker 'et appears only preceding definite NP's. When the direct object is indefinite 'et cannot appear.

In structures like (115) above, however, the presence of 'et is obligatory. (122), corresponding to (114) but lacking 'et before ma'amar 'article', is ungrammatical:

- (122) *ktiat-o_i ma'amar_j hirgiza 'et Itamar
 writing-his article annoyed acc Itamar
 'his writing of an article annoyed Itamar'

In effect, the obligatoriness of 'et in structures such as (114) results in a rather strange requirement on the \bar{N}_2 in that structure: it has to be definite, since 'et cannot appear preceding a non-definite object. Logically, there seems to be no obvious reason to exclude an indefinite \bar{N}_2 , and, in fact, the English translation of (122) is perfectly grammatical. If, however, we argue that the presence of 'et in these configurations is obligatory for syntactic reasons (namely, the necessity of marking \bar{N}_2 with Case), then the definiteness restriction on \bar{N}_2 can be naturally explained in terms of the definiteness restriction on the occurrence of 'et.

Since there is no evidence that 'et is inserted in the phonology in this case, and since there is evidence that elsewhere 'et is base-generated, we will assume that in (115) it is base-generated as well. Any failure to base-generate 'et in this position -- an option which is otherwise available in the grammar, for indefinite objects -- will, in this case, lead to ungrammaticality, since it will result in a caseless NP violating the Case filter.

Let us now look at structure (115), and compare it to a possible expansion of (72) above (represented here as (123)):

(123)

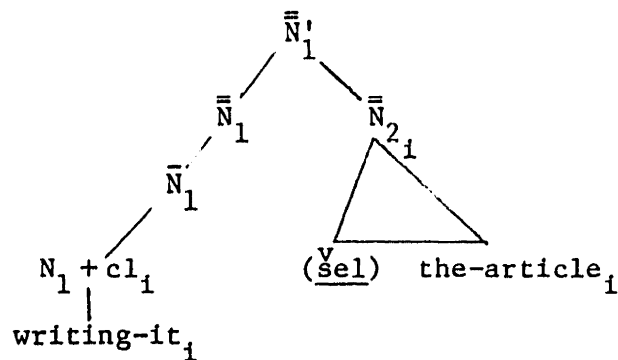

(115) and (123) seem identical in most relevant respects. Nonetheless, there is one crucial difference between them. Whereas in (123) the clitic and \bar{N}_2 carry the same index, in (115) they carry distinct indices. We thus have a minimal pair whose members differ only with respect to whether there is coindexing by the governing clitic or not.

Can it be shown that these two configurations differ with respect to extraction? Note that, since clearly that is the only relevant difference between these two structures, a difference in extraction can be attributed only to the difference in coindexing.

Consider the sentence in (124):

(124) *'et ma_i ktivat- o_j [e] $_i$ hirgiza 'et Itamar?
 acc what writing-his annoyed acc Itamar
 'his writing of what annoyed Itamar?'

Note that since we assume that 'et is base-generated, there is no longer any reason to assume that questions will differ from free relatives in extraction from structures such as (115). Nevertheless, (124), which questions \bar{N}_2 in (115), is ungrammatical with or without 'et preceding the fronted WH. One might wish to argue that, perhaps,

the ungrammaticality of (124) is to be attributed to the Case filter in some fashion; however, it is important to note in this connection that (125), which is the free relative that corresponds both to extraction from (115) and (123) can only have the meaning in (125)a, corresponding to extraction from (123), and not the meaning in (125)b, corresponding to extraction from (115):

- (125)a. ma_i $\overset{v}{se}$ -ktivat- o_i $[e]_i$ hirgiza 'et Itamar
 what that-writing-it annoyed acc Itamar
 'that which its writing annoyed Itamar'
- b. * ma_i $\overset{v}{se}$ -ktivat- o_j $[e]_i$ hirgiza 'et Itamar
 what that-writing-his annoyed acc Itamar
 'the thing [his writing of which] annoyed Itamar'

The contrast between (125)a and (125)b can be readily explained if we assume that the post-extraction structure in (125)b violates the Empty Category Principle (in (56)a above). Whereas in (125)a the $[e]_i$ is properly governed by the coindexed clitic, in (125)b the governing clitic is not co-indexed with $[e]_j$, and hence it cannot properly govern it.²⁹

A similar contrast between extraction from (115) and extraction from (123) is found in cases in which extraction takes place in logical form. Thus compare the following two sentences:

- (126)a. lo barur la-nu mi biker 'et ktivat- o_i $\overset{v}{se}$ l 'eize sefer \underline{i}
 not clear to-us who criticized acc writing-it of which book
 'it is unclear to us who criticized the writing of which book'
- b. *lo barur la-nu mi biker 'et ktivat- o_i 'et 'eize sefer \underline{j}
 not clear to-us who criticized acc writing-his acc which book
 'it is unclear to us who criticized his writing of which book'

Assuming that WH words in situ are moved by a rule applying in logical form, and that this movement rule leaves behind a variable (see, for discussion, May, 1977; Aoun, Hornstein and Sportiche, 1981; and others cited therein), and further assuming that this variable falls under the Empty Category Principle (see Kayne, 1981, for discussion), the difference in grammaticality between (126)a and (126)b can be readily explained. (127) and (128) are the relevant logical form representations of (126)a and (126)b, respectively:

- (127) (for which x_i), x_i a book ... [_{NP} N+cl_i x_i] (= (126)a)
 (128) (for which x_i), x_i a book ... [_{NP} N+ cl_j x_i] (= (126)b)

Whereas in (127) the clitic is a proper governor, since it is coindexed with the empty category, in (128) it is not coindexed with it, and hence it cannot properly govern it. Thus (128) constitutes a violation of the Empty Category Principle and the corresponding sentence, (126b) is ruled out.³⁰

Concluding that clitics can function as proper governors for co-indexed empty categories makes some interesting predictions with respect to the three genitive constructions in Modern Hebrew -- the construct state, the doubled construct state and the regular genitival structure, seen here in (129)a-c:

- (129)a. *beit ha-mora*
 house the-teacher
 'the teacher's house'
 b. *beit-a_i ^všel ha-mora_i*
 house-her of the-teacher

- c. ha-bayit ^všel ha-mora
 the-house of the-teacher

We predict that extraction, in syntax and in logical form, would be possible only in (129)b, since only in (129)b will the empty category be properly governed. This prediction is verified. Thus, of the three free relatives corresponding to (129)a-c, seen in (130)a-c below, only (130)b is grammatical. This proves that syntactic movement is only possible in (129)b:

- (130)a. *mi_i ^vše-ra'iti 'et beit [e]_i
 who that-saw-I acc house
 b. mi_i ^vše-ra'iti 'et beit-o_i
 who that-saw-I acc house-his
 c. *mi_i ^vše-ra'iti 'et ha-bayit (^všel) [e]_i
 who that-saw-I acc the-house (of)

Similarly, in (131)a-c wide scope is only possible in (131)b. Thus (131)a and (131)c are semantically deviant. The obligatory narrow scope interpretation in (131)a, c -- contrasting with the possibility for a wide-scope interpretation in (131)b -- proves that movement in logical form is only possible in (129)b as well:

- (131)a. #roš^v ^všloša 'anašim^v nir'a miba'ad la-xalon
 head three men was-seen through to-the-window
 'three men's head was seen through the window'
 b. roš-am_i ^všel ^všloša 'anašim_i^v nir'a miba'ad la-xalon
 'the head of three men was seen through the window'
 c. #ha-roš^v ^všel ^všloša 'anašim^v nir'a miba'ad la-xalon
 (meaning as in (131)a)

Let us now conclude our discussion in sections 2-4. In section 2 it was established that the relationship which holds between the clitic and the NP with which it is coindexed is that of government. In section 3 it was shown that the NP position which is coindexed with the clitic must be governed, and, in fact, must be properly governed, in order to account for the fact that extraction can apply to it. In section 4 it was shown that this position is indeed properly governed, in accordance with clause (ii) of the definition of proper government in (79) above: the clitic which governs this position is also coindexed with it, thus satisfying the definition of a proper governor.

To summarize, in sections 2-4 we have argued for a specific analysis of clitic-doubling constructions in Modern Hebrew. In particular, we assumed that the clitic in some sense deprives the complement NP of Case, so that insertion of a dummy Case marker is necessary if this NP is to be phonologically realized without violating the Case filter.

We differed from Jaeggli's analysis, however, in assuming that the complex head+clitic is non-branching. We have assumed that the clitic is a feature on the head and that, as such, it governs the NP complement which it is coindexed with.

We further argued in detail that the insertion of $\overset{v}{s}el$, the genitive dummy Case marker, has to take place in the phonological component, since it does not interact with the processes which apply prior to this component: syntactic rules and the binding conditions. However, as was pointed out, the status of dummy Case markers may vary in this respect. For instance, although it was argued that $'et$, the accusative

marker, can function as a "saving device" for Caseless NP's in certain environments, it is most probably base-generated. Here, then, we have a morphological property of a grammatical formative which generates parametric variation. We shall show that this is exactly the case in chapter 3, section 3 below.

In the appendix to this chapter we offer some comments on the way in which θ -role is assigned to doubled elements. We explore the nature of the doubled NP when it dominates an empty element and comment on the nature of empty elements when they are variables and when they receive pronominal interpretation. We suggest that the Complement Matching Requirement coupled with the process of θ -role assignment suggested in chapter 1 can account for the properties of these elements. While doing so, we review the nature of the Visibility Hypothesis proposed in Chomsky (1981) and describe the ways in which it interacts with the Case filter.

APPENDIX: Case-Marked Traces, θ -Role Assignment and the Visibility Hypothesis.

Assuming the general framework sketched in chapter 1 above and the references cited there, several questions can be raised with respect to the analysis of clitic constructions outlined in chapter 2 above. In particular, there are several aspects of clitic constructions that we did not deal with: the status of the variable which is left by WH movement from clitic-doubling configurations with respect to Case assignment, the status of the pair clitic-doubled NP with respect to the assignment of θ -role (note that this question holds regardless of whether the doubled NP is lexically realized or not) and the status of the empty category in clitic-doubling configurations with respect to the binding conditions. In this appendix, I will address all these questions. It will be suggested that the pair clitic-empty category is best characterized as a discontinuous element, whose formation is dependent on θ -role assignment and the structure of thematic matrices. It will be further suggested that given a particular interpretation of the notion chain, cases of quantifier lowering (in the sense of May, 1977) can be explained without violating the Visibility Hypothesis of Chomsky (1981). This appendix will further contain some speculations on the status of the Visibility Hypothesis and its relationship to the Case filter.

1. Variables as Case-Marked Traces

Chomsky (the Pisa Lectures) suggests that the following principle holds in the grammar:

(132) [e] is a variable iff it has Case.

The strongest motivation for the principle in (132) comes from the distribution of traces. (132) makes a clear prediction outlined in (133):

- (133)a. WH movement is only possible from Case-marked positions
 b. NP movement is only possible from non-Case marked positions

An illustration of the prediction made by (132) are the following sentences:

- (134)a. *John_i killed [e]_i
 b. *who_i did you try [e]_i to win?

Following (132), the sentences in (134)a-b are correctly ruled out. In (134)a [e]_i is Case-marked by the verb kill and hence it is a variable. As a variable, the following two principles hold for it (see Chomsky, 1981):

- (135) α is a variable iff $\alpha = [_{NP}e]$ in S bound by an operator
 (136) α must be A-free

Given (135) and (136), the ungrammaticality of (134)a follows in a straightforward way from (132): [e]_i is a variable (Case-marked trace) which violates both (135) and (136). It is not bound by an operator and it is bound by an antecedent which is in an A-position:
John_i

The ungrammaticality of (134)b can be derived in a similar fashion: $[e]_i$ in (134)b is not Case-marked and hence it cannot be a variable. Rather, it is an anaphor. As an anaphor, it has to be A-bound but in (134)b it is A-free and hence the sentence is ungrammatical.

Clearly, to the extent that (132) makes correct predictions about the distribution of NP movement vs. WH movement it is a desirable principle. However, there appear to be some counterexamples to (132). One of these counterexamples is extraction from clitic-doubling constructions in Modern Hebrew, as sketched in sections 3 and 4 above. Recall that in Modern Hebrew, extraction in free relatives is possible from the following configuration:

(137)

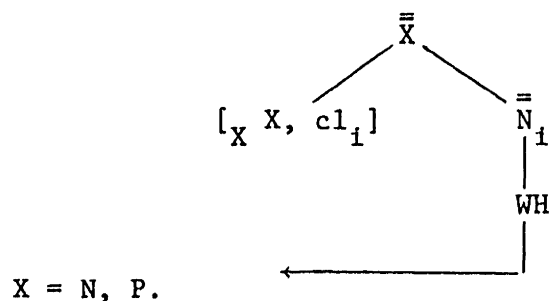

In (137) the Case features that would otherwise be assigned to \bar{N}_i are absorbed by the clitic and consequently \bar{N}_i cannot be Case-marked unless \bar{V}_{sel} is inserted (which is only possible when $X=N$). However, \bar{V}_{sel} insertion cannot apply at D-structure. Consequently, the fronted WH element cannot be Case-marked by \bar{V}_{sel} and it has to receive Case in its landing site. The trace left behind, however, is not Case-marked, since \bar{V}_{sel} insertion did not apply in the base.³¹

The unavailability of Case assignment to the fronted WH element in (137) in its initial position led us to conclude that the extraction

in (137) is grammatical only when the fronted WH element can be marked for Case by an independent device. This device was Case-marking into COMP which is available for free relatives but not for questions. This analysis accounted for the contrast between (138)a and (138)b:

- (138)a. ma_i $\overset{V}{se}$ - $xa\overset{V}{sav}ti$ 'al- av_i [e] $_i$
 'whatever I thought about'
- b. * ma_i $xa\overset{V}{sav}ti$ 'al- av_i [e] $_i$?
 'what did I think about?'

The trace in (138)a is not Case-marked, but nevertheless, it is a variable since it satisfies both (135) and (136) above. Thus it seems that (132) cannot be true for free relatives in Hebrew.

Yet another problem for (132) arises if we consider the analysis of existential sentences suggested in Stowell (1978). Following his suggestion, existential sentences in English are cases of clause internal raising (leftward movement). Existential sentences according to this analysis are generated as in (139):

- (139) [$_{NP}$] was a man in the garden ($[_{NP}]$ = null category. See fn. 35 for discussion)

Two operations may occur following the generation of (139): the post-verbal NP can be raised to subject position, leaving a trace behind and yielding (140)a, or, if movement has not taken place, a non-referential dummy, there, is inserted to yield (140)b:

- (140)a. a man $_i$ was [e] $_i$ in the garden
 b. there was a man in the garden

Note that in order for a man in (140)b to receive Case in the position following the verb to be in (140)b, we have to assume that this position is a Case position. Furthermore, WH movement is possible from this position, as is demonstrated by (141):

(141) what_i was there [e]_i in the garden?

Thus a variable is possible in the post-be position. But in (140)a NP movement is also possible from the post-be position, precisely the situation which should be excluded by (132) above.³²

Third, consider the following cases of quantifier lowering discussed in May (1977). Note in particular that (142) can have the interpretations in (143):

(142) some senator_i is likely [e]_i to speak at every rally

(143)a. It is likely that there is a senator S such that for every rally R, S speaks at R

b. It is likely that for every rally R, there is a senator S such that S speaks at R

May suggests that the narrow scope interpretation of some senator in (143)a-b is achieved by a rule of quantifier lowering which moves this quantifier from its position in the matrix into a position adjoined to the S of the embedded clause. As observed by May, this is possible (crucially) only in raising structures, where a [e] coindexed with the lowered quantifier is available to serve as the variable. Note, however, that in this case as well, (132) is violated, since the trace of raising configurations is not Case-marked and nevertheless it is a variable.³³

These problems indicate that perhaps (132) as stated is too strong and that the predictions illustrated by (133) should be otherwise derived. One could argue, for instance, that the derivation of (133) could be achieved by two other independently motivated principles: the Case filter and the θ -criterion. Following these two principles, (134)a is ruled out as movement from a θ -position to a θ -position, yielding two distinct θ -roles assigned to an antecedent and its trace (or alternatively, to one A-chain). (134)b, on the other hand, is ruled out on the grounds that the WH antecedent lacks Case, since it originated in a non-Case position and there is no device available to assign Case to it in COMP following the extraction. Assuming that the Case filter applies to WH elements, we expect the ungrammaticality of (134)b.

According to such proposal, the definition of a variable will be as in (135) above. The well-formedness condition on variables, on the other hand, will be as in (136). Thus in (141) $[e]_1$ is a variable and is A-free, as is required by (136). On the other hand, in (140)a $[e]$ does not meet the definition in (135) and hence it has to be an anaphor. Since $[e]$ in (140)a is A-free, the sentence is ruled out.

Similarly, Hebrew free relatives and cases of quantifier lowering will not present a problem. In Hebrew the trace in free relatives will be a variable following the definition in (135) and as such, it will meet the definition in (136). In quantifier lowering as well, the trace will meet (135). Thus it is classified as a variable and as such, it meets the requirement in (136).

However, deriving the distribution of WH movement from the Case filter confronts some problems.

First, consider cases in which the antecedent is clearly Case-marked, the variable is not Case-marked and the sentence is ungrammatical. These are cases of free relatives, in which the extraction is from subject of infinitival position (and compare these cases with infinitival free relatives where the extraction is from the object position):

(144)a. *whoever_i I told Mary [\bar{S} [e]_i to fix the sink]
-Case

b. whatever_i I told Mary [\bar{S} PRO to buy [e]_i for the baby]
+Case

One could argue that (144)a is ungrammatical since English does not have a special device assigning Case to WH elements in COMP of free relatives and thus the ungrammaticality of (144)a is irrelevant. We have no evidence that whoever in (144)a is Case-marked. However, in Modern Hebrew, in which there is a device which assigns Case into COMP in free relatives, the contrast between extraction from subject position and object position is attested as well:

(145)a. *mi_i ^Vše-'amarti le-Dan [\bar{S} [e]_i le-taken 'et ha-ke'ara]
who that-told-I to-Dan to-fix acc the-sink

b. ma_i ^Vše-'amarti le-Dan [\bar{S} PRO li-knot [e]_i la-tinok]
what that-told-I to-Dan to-buy to-the-baby

The Case filter cannot be appealed to to rule out (144)a and (145)a: the WH antecedent is marked for Case in these cases and nevertheless the sentences are ungrammatical. Furthermore, in cases of exceptional

generated. Following this proposal, it is again impossible to determine the ungrammaticality of (147) by any Case checking mechanism, regardless of its location in the grammatical model: since abstract WH elements do not have to be Case-marked, it follows that their failure to be Case-marked cannot rule (147) out.

2. The Visibility Hypothesis and A-Chains

Chomsky (1981) argues that the requirement that variables have Case, which is a subpart of the biconditional in (132), follows from another principle of the grammar: the Visibility Hypothesis. Loosely stated, the Visibility Hypothesis is the assumption that elements of the form $[\beta^{\alpha}]$ are 'invisible' to θ -role assignment in the LF component unless they have a feature. Such a feature can be gender, number or person on the one hand, or Case, on the other hand. Thus, for instance, PRO is visible, since as a pronominal anaphor it contains features such as number, gender and person. Similarly, Case-marked traces are visible since they contain the feature Case. On the other hand, non-Case-marked traces do not have any features in the relevant sense and hence they cannot be seen.

The latter conclusion is somewhat problematic with respect to the assignment of θ -roles. Although one may plausibly argue that non-Case-marked traces do not bear a θ -role themselves (assuming (132) above such traces are always NP traces), nevertheless, they are the element which is in the particular position in which a θ -role is assigned. Thus in a sentence such as (148), for example, the θ -role is assigned by the participle killed in the θ -position immediately following it,

although it is the full NP, John_i, which fulfills the requirement that a θ -role be assigned to every referential expression:

(148) John_i was killed [e]_i

Thus, clearly, non-Case-marked traces are visible in some sense to the rules which assign θ -roles.

Yet another problem for the version of the Visibility Hypothesis presented above is the assumption advanced in Chomsky (1981) that all empty NP elements (PRO, NP-trace, variable) are instances of the same type and their different properties are determined by the different contexts in which they occur. The following are the definitions of the environments which distinguish different empty elements:

- (149)a. α is an empty category if $\alpha = [{}_{NP}F]$, where $F \subset \phi$, F non-null
- b. i. α is a variable iff it is locally \bar{A} -bound and in an A-position
 ii. if α is not a variable then it is an anaphor
- c. if α is free or bound by a local A-binder in a θ -position then it is a pronominal
- d. if α is locally A-bound by an antecedent in a non- θ -position then α is a non-pronominal anaphor

(As the reader will no doubt notice, (d) in (149) is in fact redundant and derived from (a-c).)

The set of features ϕ referred to in (149) are features such as number, gender and person. Recall that by an A-position we refer to a position in which an argument may appear in the base (essentially, [NP,S], [NP,VP], [NP,PP] and various specifier positions). Note that the definitions in (149) also capture the character of PRO as a pronominal anaphor and hence its properties with respect to the binding conditions

(see chapter 1, section 1 for discussion).

If all the empty elements have ϕ features, it is no longer clear in what sense NP trace is less visible than a variable. Thus clearly, the crucial property for visibility for variables is Case and for PRO, an independent θ -role.³⁵

In order to capture this latter observation, Chomsky proposes that rather than applying the Visibility Hypothesis to isolated elements, it applies to A-chains. The definition of an A-chain is given in (150):

- (150) $C = (\alpha_1, \dots, \alpha_n)$ is an A-chain iff:
- i. α_1 is an NP
 - ii. α_i locally A-BINDS α_{i+1}
 - iii. for $i > 1$
 - a. α_i is a non-pronominal empty category; or
 - b. α_i is A-free
 - iv. C is maximal (i.e., is not a proper subsequence of a chain meeting i-iii).

The definition of A-chains as it appears in (150) intends to cover two kinds of chains which have somewhat different properties. The first kind is a chain headed by a lexical NP and composed of the lexical NP itself and its trace(s), if it has such traces. For this kind of A-chain, the definition in (150) intuitively speaking, states that an antecedent constitutes a functional unit with the traces it binds. The second kind of chain defined by (150) is a chain which is headed by a pleonastic element in subject position (either PRO or a phonologically realized pleonastic element such as it or there in English) which is coindexed with a post-verbal position (an NP or a clause). In this

case, the coindexing relationship which holds between the pleonastic element and the coindexed element does not enter into the binding conditions. It is a chain-forming relationship which is henceforth referred to as co-superscripting. If one assumes the notion BIND that generalizes over binding relationships and co-superscripting relationships, then the definition in (150) applies to both types of chains. (The co-superscripting chain is not relevant to our discussion in these sections. We return, however, to co-superscripting relationships and what they stand for in chapter 4 below.)

The A-chain as a whole is now the unit which satisfies various lexical requirements in accordance with the Projection Principle (see chapter 1, section 1 above). This is captured by the following principle:

- (151) The chain $C = (\alpha_1, \dots, \alpha_n)$ has the Case \underline{K} iff for some i , α_i occupies a position assigned \underline{K} by ξ .
- (152) Suppose that the position \underline{P} is marked with the θ -role \underline{R} and $C = (\alpha_1, \dots, \alpha_n)$ is a chain. Then C is assigned \underline{R} by \underline{P} iff for some i , α_i is in position \underline{P} .

Note that combining the definition of an A-chain in (150) with the Projection Principle, the right application of 'Move α ' is ensured. Since at D-structure lexical specifications have to be met and since the binding conditions and the notion of BIND are only relevant at S-structure (see chapter 1 for discussion), it follows that chains cannot satisfy lexical requirements at D-structure. Rather, at D-structure lexical specifications have to be met by the NP's themselves, generated in the position that is required by the lexical specifications. Thus

it follows that, at D-structure, every θ -position must be filled by a referential expression and every referential expression must be in a θ -position.

On the other hand, at S-structure, chains can be formed. Thus A-chains can satisfy the lexical requirement although the referential expressions themselves may no longer be in θ -positions. Following the principle in (152), the chain as a whole can satisfy the requirement that θ -role assignment be met at every level. In this sense, S-structure can be factored into D-structure and 'Move α '. The existence of 'Move α ', on the other hand, can be derived from the different properties of D-structure and S-structure: whereas in the former the relationship of antecedent-trace is missing entirely, it is represented in the latter.

Recall that we are assuming that the binding conditions hold at S-structure. This is evidenced by the following contrast (these arguments are from Chomsky, 1981, who, in turn, credits them to M. Brody and D. Sportiche):

- (153)a. which book that John read did he like?
 b. he liked every book that John read
 c. I don't remember who thinks that he read which book that John likes
 d. John said that Bill had seen HIM (HIM with focal stress)

In (153)a WH movement applied in the syntactic component and the representation of (153)a at S-structure is essentially as it is in (153)a. In this sentence, he can be understood as coreferential to John, a fact that follows in a straightforward fashion from the binding conditions: following WH movement John no longer c-commands he, thus coreferential

interpretation is allowed. In (153)b-c, on the other hand, such a coreferential reading is blocked. (153)b is a case of quantifier raising, whereas (153)c is a case of WH movement in LF. The LF representation of these two sentences is given in (154)a-b:

- (154)a. for every book x that John read, he liked x
- b. I don't remember for which person y and which book x that John liked, y thinks that he read x

Note that with respect to c-command, the configurations in (154)a-b are identical to that of (153)a. In both cases, John does not c-command he. Thus if the binding conditions hold in LF, we expect coreferential reading between John and he to be possible in these cases. Nevertheless, such a coreferential reading is impossible. If, on the other hand, we assume that the binding conditions hold at S-structure, the impossibility of coreferential reading in (153)b-c will follow immediately: at S-structure, he c-commands John both in (153)b and in (153)c and thus the coreferential reading is impossible.

A similar argument can be constructed for (153)d. In (153)d it is possible to have a coreferential reading between John and HIM. This follows from the fact that at S-structure, HIM in (153)d is a pronoun and thus it can be coreferential with an NP outside its governing category. On the other hand, assuming a rule of focus raising in LF, the LF representation of (153)d is given in (155); HIM is replaced by a variable and variables have to be free. Thus if the binding conditions held at LF we would expect the coreferential reading between John and HIM to be impossible:

(155) for \underline{x} = he, John said that Bill had seen \underline{x}

Note that from a conceptual point of view, it is desirable to assume that the binding conditions hold at S-structure. Since the antecedent-trace relationship is an inherent property of S-structure, we expect the binding conditions, which are an extension of this relationship, to hold at that level.

Recall now that the notion of A-chain, as defined in (150) above, crucially utilizes the notion BIND, which is composed of binding and co-superscripting. Since the binding conditions hold at S-structure, we still assume that the BIND relationship holds at S-structure as well. It follows that superscripting relationships, regardless of the level at which they are established, are checked at S-structure as well. Thus A-chains are formed at S-structure rather than at LF. This conclusion is quite natural: given the Projection Principle, A-chains have to exist at S-structure in order to satisfy lexical requirements. (As we will see in chapter 4 below, the notion of co-superscripting is crucial for the assignment of nominative Case. Given the Visibility Hypothesis which requires that elements be Case-marked prior to the LF component, it is obvious that the mechanism which checks superscripting has to be located at S-structure as well.)

The notion of Visibility (152)' can be now formulated as an additional requirement on (152), the principle of θ -role assignment to chains:

(152)' and C has Case or is headed by PRO

An important consequence of the definition of variables in (135)

and the definition of the notion Visibility in (152) and (152)' is that variables have to constitute A-chains by themselves. This follows from the fact that variables cannot be A-bound (if they are A-bound they would violate (136) above). Similarly, since the definition of A-chains requires that the A-chain be headed by an element in an A-position, it follows that Case-marking on the antecedent WH cannot suffice to make the variable visible. Therefore, the variable itself has to be in a Case position in order to be visible. In this way, the effects of the principle in (132) can be derived from left to right (i.e., if [e] is a variable, then it has Case).

Let us now turn back to the examples in (144)a, (145)a and (147), in which the variable was not Case-marked. Their ungrammaticality will, in fact, follow now not directly from the principle in (132), but rather, from the fact that the variables in these sentences will not be marked for Case and hence will be referential expressions which cannot be assigned θ -roles. As such, they violate the θ -criterion.

Assuming that the correct principle is, in fact, some version of the Visibility Hypothesis combined with the θ -criterion, a question is raised with respect to the grammaticality of examples (138)a and (142) under interpretations (143)a-b above, where, we argued, the variables are not Case-marked. Recall that one of these examples involved a case of quantifier lowering and the other one a case in which the variable was not marked for Case but the sentence was grammatical nevertheless due to special Case marking into COMP. In deriving the effects of the requirement that variables have Case from the Visibility Hypothesis, the notion of A-chain and the θ -criterion we make a clear prediction

(which is, nevertheless, rather hard to prove): if, in some fashion, a θ -role can be assigned to variables although they are not Case-marked, we would not expect the requirement in (132) to hold, or in other words, we would expect the sentence containing such variables to be grammatical even if the variables are not Case-marked.

We would like to argue that both the case of free relatives in (138)a above and the case of quantifier lowering in (142) and (143)a-b are precisely of this nature.

Let us first look at the definition of chain as in (150) and see if it holds for the interpretation of (142) as (143)a-b. The S-structure of (142) is as in (156):

(156) some senator_i is likely [_{NP} e]_i to speak in every rally

The trace of raising is the trace that will eventually, following the application of quantifier lowering, serve as a variable. Note, however, that at S-structure, there is no reason to prevent the formation of a chain which includes the antecedent of the trace, some senator, and the coindexed trace. This chain will be well-formed at that stage, since the trace is still only an 'NP trace' and is properly A-bound, as is required by the definition in (150). Since the binding conditions hold at S-structure, no condition will be violated. Note, however, that in the LF component, when the trace in (156) is converted into a variable, the binding conditions are no longer relevant. Thus the fact that this variable is A-bound (by the trace of the phrase some senator) can no longer rule the sentence out. Furthermore, the variable is already part of a chain that is visible by virtue of the

fact that it has Case, namely, the Case of the antecedent in the subject position. Note that, in fact, the configuration in (156) as it will appear after the application of quantifier lowering will violate the principle in (132) twice. First, it will include a variable which is not Case-marked, namely, the trace in the position of the subject in the embedded infinitival clause. Second, it will include a trace which is not a variable, and which is nevertheless Case-marked, namely, the trace of some senator following the lowering. However, if we view (132) as a byproduct of the Visibility Hypothesis, combined with the notion of A-chain and the θ -criterion, the interpretations of (142)(=156) as in (143)a-b do not violate any principles.³⁶

3. On Assigning θ -Role to Doubled Categories

Recall that the other case in which the variable does not have Case is in doubling configurations. In these cases, demonstrated by the diagram in (137) and the grammatical sentence in (138)a, extraction took place from a non-Case position, and hence grammaticality can be achieved only if the moved WH can be assigned Case in its landing site. Thus the configuration in question is as in (157):

(157) $[_X X, cl_i]$ $[_{NP} e]$

Let us consider the nature of the combination in (157). We know that it appears in post-extraction configurations, such as (138)a. We further know that it appears when no extraction takes place, as in (158):

(158) $beit-o_i [e]_i$ 'omed 'al ha-giv'a
 house-his stands on the-hill
 'his house stands on the hill'

The construction in (157) where the empty category [_{NP} e] is not a variable presents yet another problem: we have an empty category which is not a variable, and hence it is an anaphor. On the other hand, it is governed and hence it cannot be PRO. It follows that it is a non-pronominal anaphor and as such, it has to be bound. However, as evidenced by (158), the empty category in this case does not have an A-binder.

It is clear, that when the combination in (157) appears in non-extraction configurations such as (158), it has a pronominal meaning. It is, then, plausible to assume that the sequence clitic_i [e]_i in (157) functions as a pronominal. As a pronominal sequence, it exhibits typical properties of pronominal elements. Thus it is disjoint in reference from the subject when X in (158) is P, but it can freely corefer to the subject when X in (158) is N (and compare with the equivalent sentences in English):

- (159)a. *Rina_i xašva^V 'ale-ha_i
 'Rina thought about her'
 b. Rina_i makira 'et 'axot-a_i
 'Rina knows her sister'

Further, it can be coreferential with an NP which is outside its governing category:

- (160) Rina_i 'amra še-Dan xašav^V 'ale-ha_i
 'Rina said that Dan thought about her'

In view of these facts, it is plausible to assume that the combination in (158) is given a pronominal interpretation. In a sense, then, the clitic+[e] combination is a discontinuous element, in which the clitic

supplies the number, gender, person and Case features and the empty element supplies the relevant argument position.

Let us try and formulate this proposal. Recall that in chapter 1 section 3.2 we argued for a particular process of θ -role assignment. Following this process, every complement-selecting head has a thematic matrix with an empty slot for the referential expression of the selected complement. The assignment of a θ -role is achieved by transferring this index into the θ -slot. Recall further that we assumed that, when a clitic is attached to the head, it has to be associated with a thematic matrix of this sort in order to be well-formed. We then defined the Complement Matching Requirement as a condition on the well-formedness of thematic matrices:

- (161) Given a thematic matrix \underline{T} , $*\underline{T}$ if \underline{T} contains referential indices i, j and $i \neq j$

The Complement Matching Requirement ensures that the clitic and the complement will not carry conflicting indices.

Let us now review the structure of thematic matrices. Recall that they have the structure in (162):

- (162) $[_X X \left[\begin{array}{c} (cl_i) \\ \Delta \\ \theta_1 \end{array} \right]] NP_i$

Let us further assume that along with the referential index in (162), the NP transfers some vital semantic information. Note that this assumption is natural and quite necessary if we expect the thematic process to account for selectional restrictions as well. Thus in a

sentence such as (163)a, the theme, 'the boy', will transfer, along with its index, some semantic information, for instance, +human, in order to prevent the ungrammatical (163)b:

- (163)a. the tiger frightened the boy
 b. *the tiger frightened the cage

Note, however, that given the nature of the combination in (157) above, no additional information is transferred with the index of the empty category. The only information which exists in a thematic matrix of the sort produced by (157) above is the gender, number, person and Case which are part of the clitic. We believe that this thematic matrix is given a pronominal interpretation. Note that it contains all and only the elements which would be in a thematic matrix of a free (non-cliticized) pronominal form: gender, person and number markers, Case features and a referential index of an argument. The structure of the thematic matrix in question (both for the combination in (157) and for a free-standing pronoun) is as in (164)a (and compare with (164)b, which is the thematic matrix of the boy in (163)a above):

- (164)a. $[_X X, \left[\begin{array}{c} [\text{gender, number, person, Case}]_i \\ i \\ \theta_1 \end{array} \right]] \text{ NP}_i$
 b. $[_V \text{ frighten}, \left[\begin{array}{c} i, +\text{human} \\ \text{theme} \end{array} \right]] \text{ NP}_i$

As a discontinuous pronominal element, the combination in (164)a is no longer treated as a non-pronominal anaphor. Rather, it is a pronoun and as such, it is subject to part B of the binding conditions.

It must be free in its governing category. Consequently, we expect the pronominal behaviour of the combination in (164)a, and indeed, this behaviour is attested in (159) and (160) above. Further, (164) is now the unit that satisfies the Projection Principle. It is a one-member unit, similar to pronominal elements. The θ -role which is assigned to it is that of θ_1 in (164)a and the Case which it has is the Case which is absorbed by the clitic and which, in turn, makes it visible in accordance with (152)' -- the Visibility Hypothesis.

Note that a pronominal element will be formed out of the combination in (157), whether the empty category is a base-generated empty element or a variable. In the latter case, the pronoun will receive the interpretation of a bound variable.

The process suggested above for the formation of a discontinuous element can be extended to clitic configurations in other languages as well. Thus consider, for example, the reflexive clitic se in French (and similar reflexive clitics in other Romance languages) as given in (165):

- (165)a. Jean se lave
'Jean washes himself'
- b. Marie s'habille
'Marie dresses herself'

Both in the case of laver 'to wash' and in the case of habiller 'to dress' the verb takes a thematic object. Following our assumption that thematic requirement cannot be met by a clitic but have to be met by an element in an argument position, we would like to claim that the structure of (165)a-b is as in (166):

- (166)a. Jean se lave [e]
 b. Marie s'habille [e]

It is the empty category which satisfies the requirement for a theme object both in (166)a-b. The structure which we suggest for thematic matrices further enables us to state in a natural way the fact that the combination se + [e] is assigned an anaphoric reading. Let us assume that the rule that will interpret this combination as a discontinuous element will assign anaphoric interpretation to combinations such as (167):

$$(167) \quad \left[\begin{array}{c} \text{se} \\ i \\ \theta_1 \end{array} \right] \quad \text{NP}_1$$

The anaphoric interpretation given to (167) will then correctly rule out any occurrence of a lexical NP in (167) (note that one could plausibly argue that such NP cannot appear due to the absorption of Case features by se. Such an approach, however, will not explain the complete absence of clitic-doubling with reflexive clitics, even in languages which allow for doubling, such as Rumanian and River Plate Spanish). Such an NP will be both an R-expression, which has to be free, and an anaphoric expression, by virtue of the particular interpretation assigned to (167). Thus it will have to be free and bound at the same time. On the other hand, [e] can freely appear in this position, since it is not necessarily an R-expression.

4. Some Theoretical Speculations

Let us look again at the Visibility restriction, as it is expressed in condition (152)' on the principle of θ -role assignment in (152). Note that this condition includes a rather unnatural disjunction between PRO and Case, which it is desirable to eliminate.

A greater problem for the Visibility Hypothesis in (152)', however, is its mode of interaction with the Case filter. Given the Case filter in the phonological component, as we have assumed thus far, it is clear that the Visibility Hypothesis is designed to block exactly one sort of configuration, namely, a configuration in which a variable is in a non-Case-marked chain.

In order to see that this is the case, consider all the types of NP's which are covered by the Visibility Hypothesis: lexical NP's, PRO, Case-marked traces and non-Case-marked traces.

Note that lexical elements, if they do not have Case, will be ruled out by the Case filter, quite independent from whether they are visible in LF or not. Thus the Visibility Hypothesis is not required in order to rule out non-Case-marked occurrences of lexical NP's.

PRO is visible by stipulation, as is stated in (152)'. Thus the Visibility Hypothesis cannot be utilized to rule out ungrammatical occurrences of PRO. Similarly, Case-marked traces are visible, since they have Case.

Now consider non-Case-marked traces. First, consider a non-Case marked trace which is not a variable by the definition in (149)_b above. Such an element, if not a variable, is a non-pronominal anaphor (=NP trace) and hence it has to be bound, following the binding conditions.

In order to be bound and nevertheless violate the Visibility condition it has to be bound by an NP in a non-Case position, as in (168):

(168) *I tried [\bar{S} Mary_i to be left alone [e]_i]

In (168) the non-Case marked trace is bound and nevertheless it is in a chain which does not have a Case. Hence, it is not visible. However, (168) is clearly a violation of the Case filter, since the antecedent in the A-position, Mary_i, is not Case marked.

Thus the only case in which an ungrammatical sentence is ruled out exclusively by the Visibility Hypothesis is the case of variables which are not in a Case-marked chain. Given this state of affairs, it is not clear that the Visibility Hypothesis is preferable to a condition which restricts the distribution of variables in LF and which is roughly as in (169):

(169) Variables have to be in Case-marked chains

It is also possible that the principle in (169) can be subsumed under the Case filter. In this case, there would be no reason to believe that (169) is located in the LF component. Clearly, the principle in (169) should be derived from a more general principle of grammar. The attempt to derive (169) from other principles or to subsume it under the Case filter will not be pursued in this study. We will, however, assume that the Visibility Hypothesis should be replaced by a condition that will capture the generalization expressed by (169). We will further assume that all other elements are visible in LF without any need for further stipulations. Thus, for instance, in examples such as (170), in which Y_{sel} is inserted in the phonological component,

we will assume that the object of \bar{S}_{el} , 'the teacher', is visible, although it does not have Case at S-structure:

- (170) ha-bayit \bar{S}_{el} ha-mora
 the-house of the-teacher
 'the teacher's house'

An alternative approach is suggested in Chomsky (1981). It is argued that the Visibility Hypothesis subsumes the Case filter. Thus instead of having a filter that is best characterized as a morphological filter, the requirement that NP's have Case should be regarded as a well-formedness condition on the assignment of θ -roles in the LF component. Note that crucially, this approach entails that the Case filter holds for A-chains only, since non A-chains do not have to be assigned a θ -role. It further entails that all Case assignment is prior to the LF component and that there are no Case assignment rules which apply in the phonological component.

In fact, Chomsky assumes that there are no Case assignment rules at all. Rather, lexical NP's are base-generated with Case features which are then checked at S-structure. Note that this assumption is compatible with the assumption that WH elements, which are not part of A-chains, do not have to have Case: at S-structure, the WH words are in COMP and the Case assignment is checked on the variable which is left behind.

The constructions discussed in this study indicate that this approach is inadequate. First, we have shown that the differences between free relatives and questions in Modern Hebrew can only be explained if we assume that WH elements have to be Case-marked. Thus,

clearly, the Case filter has to hold for WH elements in spite of the fact that they are not part of A-chains.

Note that this is a rather desirable result. In many languages, WH elements are in fact overtly Case-marked, as are topicalized elements and dislocated elements. All these elements are not part of A-chains, and nevertheless we would like to claim that they have to be Case-marked.

Second, we have argued in chapter 2 that the rule of \underline{v} sel insertion applies in the phonology. In chapter 3 below, some additional evidence to that effect will be discussed. However, if there are Case-marking rules in the phonological component, it is clear that there has to be Case-checking mechanism exactly like the Case filter in this component.

Although we will not pursue the comparison between these two systems in this study, it is our firm belief that the Case filter should be viewed as a morphological operation and that it should not be abandoned. Thus we find the assumption that various Case-marking rules operate in the phonological component quite natural. Although the nature of the generalization in (169) above will not be further elaborated on, we hold that it is desirable to try to derive this generalization from the Case filter.

5. Case Assignment in Existential Sentences

A residual issue that was not settled in the above discussion is the solution to the contradiction that was observed in (139)-(141) above. Recall that in this case we had NP movement and WH movement

applying from the same position. The crucial sentences are repeated here as (171)a-b:

- (171)a. a man_i was [e]_i in the garden
 b. what_i was there [e]_i in the garden?

Although we will not elaborate on the solution to this contradiction, we will indicate the way in which the notion of chain described above can account for this contradiction in a natural way, if we assume a particular procedure of nominative Case assignment. (We return in greater detail to nominative Case assignment in chapter 4 below.)

Chomsky (1981) proposes that the rule for nominative Case assignment is as in (172):

- (172) assign nominative to NP iff it is governed by AGR and co-superscripted with it.

Further, he assumes that a rule of co-superscripting applies at D-structure, co-superscripting AGR and the subject position. Thus in (171)a nominative Case is assigned to a man following the application of 'Move α ' since the position in which a man appears at S-structure has been co-superscripted with AGR in the base. On the other hand, we will assume that the verb be does not assign Case (but see chapter 4 for some further discussion). It follows that in a configuration such as (173), nominative Case cannot be assigned to a man, unless it is moved to the subject position:

- (173) [_{NP}] was a man in the garden

In sentences such as (174), where there is inserted, there is co-superscripting with AGR since it is inserted in the subject position and hence it is assigned a nominative Case. Chomsky assumes further, that there is co-superscripted with the post-verbal NP. As such, these two elements form a chain, which is marked as nominative:

(174)a. there was a man in the garden

b. thereⁱ (AGRⁱ) a manⁱ

Note that extraction from the post-verbal position in (174) will result in a visible trace, since it is part of a Case-marked chain. On the other hand, when 'Move α ' applies to result in (171)a above, the trace left behind is not a variable since it does not conform to the definition of variables either in (135) above or in (149).

Let us now summarize our discussion in this appendix. We have attempted to review different problems which are associated with the empty category in clitic configurations. It has been shown that the empty element which is generated under the NP in these configurations appear to violate the binding conditions and the Visibility Hypothesis, whether stated as (152)' or as (169) above. These problems can be overcome if we assume that the thematic matrices which include the clitic and the adjacent empty element are reanalyzed as a pronominal element. Once a pronominal element has been formed, it behaves like a pronoun with respect to the binding conditions and it is visible by virtue of the Case features which it bears.

A few other issues were touched upon in this appendix: the analysis of quantifier lowering, the interaction of the binding conditions and the formation of A-chains and the assignment of Case in existential constructions. The Visibility Hypothesis was reviewed and we explored its status with respect to the Case filter. We concluded by assuming that the Case filter should not be abandoned, although it should be reformulated so as to include the generalization expressed by principle (169) above.

FOOTNOTES: CHAPTER 2

1. In many respects, the head of the construct state and its complement behave as one lexical unit. Thus, for instance, main stress falls always on the complement, and thus the head is subject to various reduction rules which operate in non-stressed environments (see Prince, 1975, and McCarthy, 1979, for discussion). Furthermore, there is a strong tendency to lexicalize construct-state combinations, treating them as a single lexical entry: beit-sefer (literally 'book house') 'school'; orex-din (literally 'law editor') 'lawyer'; etc. These, I believe, do not have the structure in (7). Rather, they have the properties of regular nouns. (See also footnote 12 for some more discussion.)

2. In complex structures such as (24), I have tried to use a consistent notation to indicate the structural relationships between different elements in the tree. In particular, all expansions of the same maximal projection are numbered with the same subscript. The maximal projection is marked \bar{X}_y (y an integer). In cases with an adjoined \underline{S}_y^v phrase, like (24), the node dominating the adjunction is marked with a prime: \bar{X}'_y . (There is an implicit theoretical assumption here that \underline{S}_y^v phrases are adjoined to maximal projections -- an assumption that will not be argued for directly in this study.) In (24), then, each introduction of an independently numbered \bar{N} signals the introduction of a maximal projection.

3. Clitics, like other complements of the head in the construct state, change stress patterns. There are also phonological and morphological

factors which determine the form of the clitic, which do not interact with any syntactic phenomenon. The full table of clitic forms is given in (i):

(i)	1 sg:	-i, -ay	1 pl:	nu
	2 sg masc:	-xa, -exa	2 pl masc:	-xem
	2 sg fem:	-ax, -ix, -ex	2 pl fem:	-xen
	3 sg masc:	-o, -av	3 pl masc:	-am, -hem
	3 sg fem:	-a, -ha	3 pl fem:	-an, -hen

The table in (i) represents, roughly, the ways in which these clitics are pronounced in Modern Hebrew and should not be taken to represent their underlying forms.

4. Note, however, that the English sentence corresponding to (35) is ungrammatical as well:

(i) *the teacher's its house (cf. 'the teacher's dog's house')

As will be shown below, the argument for clitics as non-arguments does not depend crucially on the ungrammaticality of (35).

5. Note that (41) cannot be ruled out on the grounds that the clitic on sel^v cannot be coreferential with the coindexed position. If such a clitic appears following a N+clitic combination, the coindexing is grammatical:

(i) $\text{beit-}i_i \text{ } \overset{v}{\text{sel-}}i_i$
house-me of-me
'my house'

A question which arises with respect to (41) and (i) involves the

structure of $\overset{V}{s}el$ +clitic combinations. Do they involve the structure in (26)? In other words, is there, in these cases, an argument position which is here an instance of \emptyset ? I believe that this is indeed so. Note that it follows that if another $\overset{V}{s}el$ is inserted, we should be able to get "clitic tripling" -- and, in fact, (ii) is not too bad:

(ii) ?beit-am_i $\overset{V}{s}ela$ -hem_i $\overset{V}{s}el$ ha-talimidim_i
 house-them of-them of the-students
 'the students' house'

The marginality of (ii), it seems to me, is entirely due to its extreme redundancy, but it is quite grammatical.

Another question which arises with respect to (41) involves the stage at which the clitic is spelled out on $\overset{V}{s}el$. Note that since we have assumed so far that $\overset{V}{s}el$ is inserted in the phonological component, this might raise some questions with respect to the stage at which clitic spell-out on $\overset{V}{s}el$ takes place. We will return to these questions in chapter 3, section 3.3, where the precise process of $\overset{V}{s}el$ insertion will be discussed in detail.

6. Yet another piece of evidence for the change in the definition of c-command suggested in (42) is provided by Reuland (1981). This change is required in order to prevent the head of the specifier in possessive constructions in English from c-commanding (and thus governing) elements which are in the domain of the head of the full NP. The relevant configuration is as in (i):

(i) [NP [NP [N John] 's] [\bar{N} [AP beautiful] [N brother]]]

7. It will be shown in section 4.2 below that when the head of the construct state is a derived nominal, two complements of the head can appear, one of which is construed as the subject and the other as the object. When this is the case, there is a preferred order: the object usually follows the head, and the subject is expressed by means of a \bar{S} el phrase. Violation of this order does not lead to ungrammaticality but results in a marginal sentence. Thus, (i) is marginal, while (ii) is perfectly grammatical:

- (i) ?'axilat Dan \bar{S} el ha-tapuax
 eating Dan of the-apple
 'Dan's eating of the apple' | ?
- (ii) 'axilat ha-tapuax \bar{S} el Dan
 eating the-apple of Dan
 'Dan's eating of the apple' | .

The meaning intended by (i) can be rendered without marginality if the accusative Case marker 'et is used rather than \bar{S} el:

- (iii) 'axilat Dan 'et ha-tapuax
 eating Dan acc the-apple | ?
 (meaning as in (i))

Returning now to (44), the marginality of this configuration is similar in nature to that of (i), and seems to derive from the same source: since the teacher in this phrase is construed as the subject, and her-self as the object, the order is marked. If, as in (iii), we replace \bar{S} el with 'et, the sentence is perfectly grammatical:

- (iv) re'iyat ha-mora 'et 'acma
 view the-teacher acc herself
 'the teacher's view of herself'

Note that, since obviously in (iv) ha-mora 'the teacher' has to c-command 'acma 'herself', it would be hard to argue that such a relationship holds in (iv), but not in (44).

This peculiarity of the structure of the construct state, like other peculiarities noted before (e.g. the right-branching constraint) will not be pursued here (but see Berman, 1979, for discussion).

8. The reflexive form in Modern Hebrew is itself a construct state of the form noun+clitic. This would seem to create a problem for sentences such as (45). In section 2.4 below it will be argued that clitics can be coindexed with complement NP's only in case they govern them. In the structure corresponding to (45), however, such a government relationship does not hold, although coindexing does. The presumed structure of (45) is given in (1):

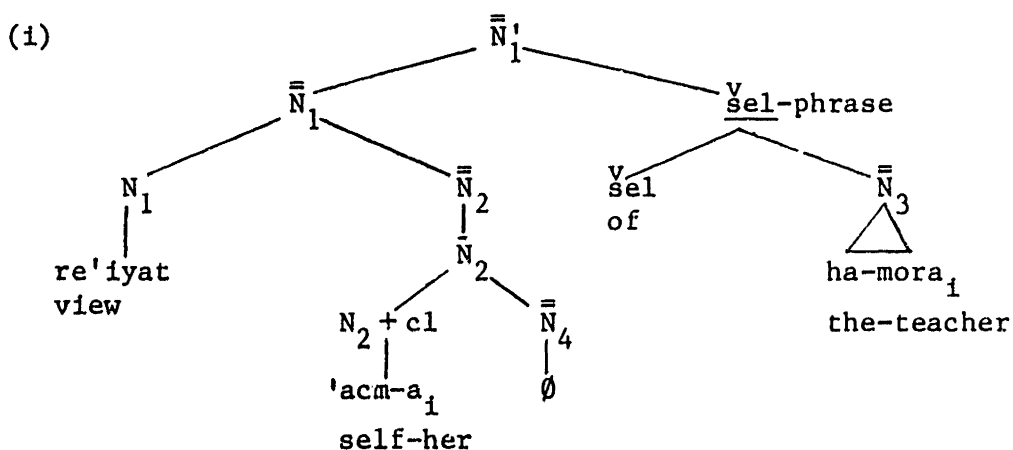

Note that the clitic in (1) does not govern \bar{N}_3 . I believe, however, that this is not a problem. The coindexing relationship which holds in the case of anaphor and antecedent does not hold between the clitic in \bar{N}_2 and \bar{N}_3 . Rather, it holds between the full \bar{N}_3 and \bar{N}_2 , the latter

being an anaphoric expression. In fact, I would like to argue that the clitic in \bar{N}_2 is simply a marker of pronominal agreement, thus rendering the reflexive form a free-standing pronoun which cannot be further analyzed into a N+clitic combination and an empty \bar{N} . The structure of (45), thus, is not really (i), but rather (ii):

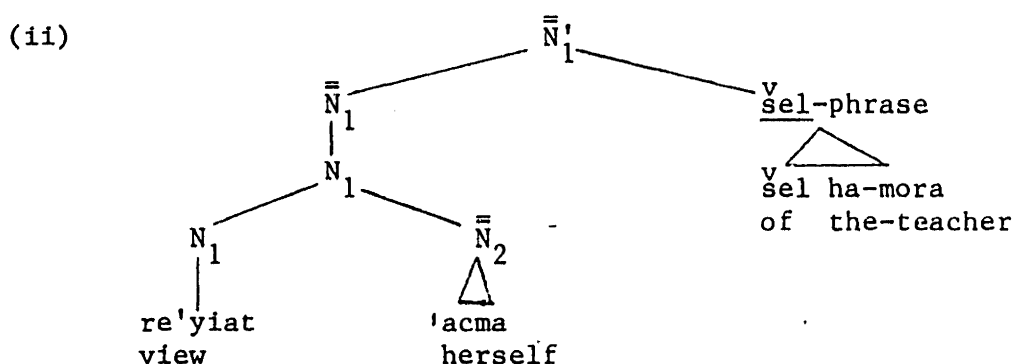

9. Note that we argue that in structures such as (43), \bar{N}_2 and \bar{N}_3 c-command each other, and that, consequently, each of these positions can serve as an antecedent for the other, as demonstrated by (i) and (ii):

(i) re'iyat ha-mora 'et 'acma
view the-teacher acc herself
'the teacher's view of herself'

(ii) re'iyat 'acma ^Vsel ha-mora
view herself of the-teacher
'the teacher's view of herself'

This situation seems to present a problem for the binding conditions: in a situation of mutual c-command, the antecedent NP is c-commanded by the anaphor, and hence it is not free. Since it is not free, it violates the binding conditions. One possibility of solving this conflict would be to conceive of the binding conditions as a process of index trans-

mission from top to bottom, essentially following Chomsky (1980). Thus in a sentence such as (iii) below, the c-commanding NP John_i will transmit an index to the c-commanded NP himself. Since lexical anaphors can only inherit their index from a c-commanding NP, it will follow that if himself does not have a c-commanding antecedent in its minimal governing category, it will not receive an index; hence the sentence will be ruled out:

(iii) John_i saw himself_i



index transmission

Prior to the transmission of an index, however, a lexical anaphor does not have a referential index; hence it cannot serve as an antecedent for an NP. Returning to (43) above, and assuming our reinterpretation of the binding conditions, it is clear that either one of the \bar{N} 's can be an antecedent to the other in the sense mentioned above, since each one of them can transmit an index to the other. However, this situation will never result in conflicting indices. For the full NP, such a system could make use of the distinction between referential and anaphoric indices suggested in Chomsky (1980). Thus, parallel to (iii), but ungrammatical, we would have (iv), in which the anaphoric index cancels the referential one. The lexical NP does not have a referential index, and the sentence is ungrammatical:

(iv) he_i saw John_i, {i}

10. Yet another possibility would be to adopt the proposal of Safir (1981), according to which expletive [e] does not have to be properly governed. Since Safir's proposal entails a different treatment of the pro-drop phenomenon than the one advanced in chapter 4 of this study, his proposal will not be adopted here.

11. Note that our explanation does not account for the reading in which the empty category is regarded as the complement of the head noun (and is governed by it and by the clitic) and the sel^v phrase is assigned a different referential index. It seems to me that pragmatic factors are at play here. Whenever a lexically realized NP can be construed as the complement, it, rather than the empty category, is construed as that complement. A similar phenomenon exists in River Plate Spanish. In a situation in which an a phrase can be construed either as a PP or as a doubled element, the latter reading is greatly preferred:

- (1) lo envié a Juan
 him send-we to Juan
 'we send it/him to Juan' / 'we send Juan'

Where River Plate Spanish shows a preference, Modern Hebrew shows a sharper contrast, actually ruling out all other interpretations, in the absence of a sharp intonational break.

12. There are, in fact, some counterexamples to our analysis. Thus, the following is a grammatical sentence, although one could argue that its structure is identical to that of (66):

- (i) signon ktivat-o_i ha-maksim ^vsel Dan_i
 style writing-his the-charming of Dan
 (masc) (fem) (masc)
 'the charming writing style of Dan'

The class of cases which violate the government requirement is semantically restricted. It consists solely of "manner" nouns as heads and gerunds as complements: derex ha-rica 'way of running', ofen ha-halixa 'manner of walking', etc. Each of these elements when appearing with other nouns obeys the government constraint:

- (ii) *signon kis'ot-av_i ha-xadaš ^vsel Dan_i
 style chairs-his the-new of Dan
 (sg) (pl) (sg)

- (iii) *masluley ricat-o_i ha-'arukim ^vsel Dan_i
 tracks running-his the-long of Dan
 (pl) (sg) (pl)

Since the class of counterexamples is semantically so restricted, I will assume that only elements which obey these semantic restrictions are reanalyzed as a compound of sorts, and that this compound occupies the head position. In this sense, the clitic is actually a clitic on the full compound, which occupies the head position; thus it does govern the coindexed NP. These configurations would then have the structure in (iv) (corresponding to (i)):

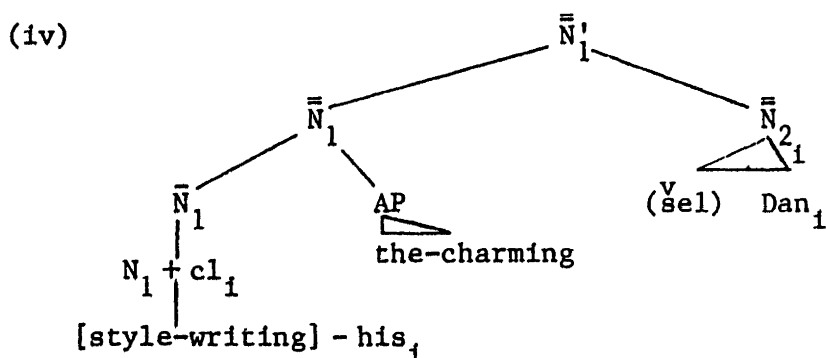

13. Stowell (1981) points out that an additional condition may be required on the formulation of Vsel insertion, if we wish to argue that the rule of Vsel insertion is analogous to the rule of of insertion in English. The rule of of insertion is given in (1):

- (1) $\emptyset \longrightarrow \text{of} / [_{NP_i} \dots \text{---} NP_j \dots]$
 where NP_j is immediately dominated by NP_i^j

The restriction on the formulation of of insertion is intended to block exceptional Case marking by of in English. The question of where in the ~~grammar~~ of insertion applies will not be discussed in this study.

14. The ~~question~~ question of whether the change in the definition of proper government should be extended to English or not is left open in this study. Note, however, that the main case in which proper government by nouns is required is in phrases such as (1):

- (1) the city's destruction [e]

With respect to (1), see Jaeggli (1980), who argues that the empty category in such examples is properly governed by its antecedent rather than by the noun destruction.

15. The free-standing direct object forms are given in the chart below:

- | | | | | |
|-----|------------|-------|------------|--------|
| (1) | 1 sg: | 'oti | 1 pl: | 'otanu |
| | 2 sg masc: | 'otxa | 2 pl masc: | 'otxem |
| | 2 sg fem: | 'otax | 2 pl fem: | 'otxen |
| | 3 sg masc: | 'oto | 3 pl masc: | 'otam |
| | 3 sg fem: | 'ota | 3 pl fem: | 'otan |

Although historically it is clear that the free-standing direct object forms derive from the combination of the object marker 'et with clitics, I believe that they no longer admit of this analysis, and that they are now on a par with the nominative pronouns,¹ which are also free-standing. Thus, in contrast to our treatment of prepositions with clitics, we will not regard the direct object pronominal form as having the structure 'et+cl [e]. Rather, they are full NP's, containing no empty category.

16. The discussion of relative clauses in this section is restricted to relativization of non-subject constituents. The relativization of subject position obeys somewhat different constraints which are irrelevant for our discussion. We are assuming here the analysis of relativization in Hebrew in Borer (1979). For some other analyses, see Hayon (1973) and references cited therein.

17. Kayne argues that the availability of preposition stranding in English and its absence in French can be explained if we assume that prepositions are not proper governors. It follows that an empty category following a preposition is ruled out as a violation of the ECP unless some other mechanism is available to properly govern it. Such a mechanism, Kayne suggests, is the transmission of superscript from the verb to the preposition. This transmission is only possible in English, since in English prepositions assign Case in the same way verbs do. (See Kayne, 1980b for detailed discussion.) This compatibility of Case assignment procedures allows for the transmission of superscripts. In French, on the other hand, the process of Case assign-

ment by prepositions differs from that of verbs; hence the transmission of a superscript is impossible. In languages in which such transmission is possible, once the superscript has been transmitted, the verb itself can properly govern the empty position following the preposition.

Since in Hebrew both preposition stranding and noun stranding (see (78) above) are impossible, we will adopt the assumption that prepositions are not proper governors and that, furthermore, the superscripting process available in English is impossible in Hebrew. Interestingly, verbs in Modern Hebrew do not take clitics, unlike nouns and prepositions (see the discussion in the text below). Given our assumption that clitics are a spell-out of Case features, it is quite possible that the lack of verbal clitics in Modern Hebrew is a reflection of these different Case-assignment procedures.

Note that insofar as Kayne attributes the distinction between English and French (or, for our purposes, Hebrew) to the Case-assignment properties of prepositions in these languages, his analysis is compatible with our view of the nature of parameters.

18. Some occurrences of direct object pronouns in free relatives are attested in phrases such as (i): //

(i) mi_1 $\overset{v}{s}e$ -racitem le-hakot 'oto₁ be-yaldut-o₁
 who that-wanted-you to-hit him in-childhood-his

In fact, the direct object pronoun in (i) is obligatory, and (ii) is ungrammatical:

(ii) $*mi_1$ $\overset{v}{s}e$ -racitem le-hakot [e]₁ be-yaldut-o₁

The regular relative clause corresponding to (ii) is ungrammatical as well:

- (iii) *ha-'iš^v še-racitem le-hakot [e] be-yaldut-o
 the-man

We do not offer a detailed explanation of these cases in this study. Note, however, that in (i) the extraction could take place from the post-clitic position, rather than from the direct object position. The elimination of be-yaldut-o_i from (i) will result in the same ungrammaticality as (89)c in the text:

- (iv) *mi_i še-racitem le-hakot 'oto_i ba
 who that-wanted-you to-hit him came
 'the one you wanted to hit came'

This, however, would not account for the ungrammaticality of (ii), in which extraction was from the direct object position. I am indebted to Edit Doron for pointing out these examples to me. For an interesting discussion of these examples and similar ones in Arabic see Doron (1980) and Aoun and Sportiche (1981b)

19. I believe that the availability of a "saving device" for various categories is language specific. Thus, in Tigre, there is a saving device for PP's as well, as demonstrated by (i). The same holds for Lebanese Arabic, as demonstrated by (ii):

- (i) Lilat 'ʕgʕl gali_i warakat nad'at 'ʕt-tu_i
 Lilet to Ali (m) letter (f) sent to-him_i
 'Lilet sent a letter to Ali' (Jake, 1980)
- (ii) h̄kīt ma9-o_i la-Karim_i
 talked-I with-him to-Karim
 'I talked with Karim' (Aoun, forthcoming)

20. In diagram (100), we left open the question of the structure of free relatives: are they true NP nodes which have an empty head (as assumed by Groos and van Riemsdijk), or are they instances of \bar{S} marked with the feature [+N], taking COMP as its head? The latter was proposed to me by K. Hale (personal communication); see also Fassi Fehri (1980), where such a proposal is pursued. Although we lean towards the latter hypothesis, we will not argue for this analysis in this study. Note that assuming that Case is, in fact, assigned to the NP dominating the free relative (or, in the case of the \bar{S} proposal, to the \bar{S} marked [+N]), both proposals can capture the generalization expressed by (100). The first proposal would claim that the Case features percolate to the first phonologically realized element, whereas the latter proposal would claim that they are manifested on the head, that head being the WH-word in COMP.

The proposed analysis of free relatives sketched in these paragraphs has some interesting consequences for the requirement that variables have Case, suggested in Chomsky (Pisa lectures). These consequences will be discussed in detail in the appendix to chapter 2.

21. Grimshaw (1977) shows that the WH element in free relatives has to satisfy both the categorial requirements of the gap and the categorial requirements of the matrix. This requirement is not true, for instance, of embedded questions. Thus we find the following contrasts:

- (i) I asked how tall Bill is [e]
- (ii) I asked where you put your coat [e]
- (iii) I asked what you ate for lunch [e]

- (iv) *I will hit however tall Bill is [e]
- (v) *I will hit wherever you leave your coat [e]
- (vi) I will hit whatever you throw me [e]
- (vii) I will become however wealthy you become [e]
- (viii) *I will become wherever you put your coat [e]
- (ix) I will become whatever you want me to become [e]

The ungrammatical cases (iv), (v) and (viii) are free relatives in which the matching requirement is not met; the matrix verb does not sub-categorize for an AP (iv) or a locative phrase (v, viii), while the fronted WH leaves a gap of this type.

22. Extraction of PP's from nominal structures is rather restricted in Modern Hebrew by conditions that are poorly understood. Note, however, that there are no structural considerations that would render the extraction in (102)a better than the extraction in (102)b. In both cases, the extraction is clearly from the nominal phrase (as opposed to the VP), and thus the contrast between them is telling. The same holds for the contrast between (103)a and (103)b. For some discussion of extraction from NP in Hebrew, as well as for the observation that \bar{V} sel phrases can never be extracted see Reinhart (1979).

23. Note that if it could be shown directly that the clitic in (106), and not some other element, properly governs the empty category under \bar{N}_1 , it would shed interesting light on the distribution of clitics in Modern Hebrew. It would suggest that clitics were preserved in all and only the environments in which the lexical category does not function

as a proper governor. Thus, clitics on verbs disappeared while clitics were retained on nouns and prepositions. Further note that the clitics in post-nominal and post-prepositional positions enable extraction to take place from a position that otherwise would not allow extraction.

If we assume that languages strive to avoid redundancy, we may get some insight into the nature of this distribution. Note that, following verbs, clitics are redundant as proper governors. Furthermore, the language has developed a parallel way to express direct object pronouns. For this reason, clitics on verbs began to disappear. On the other hand, clitics on nouns and prepositions are essential as proper governors. Thus, they have not disappeared and the language has not developed a parallel way of expressing pronominal objects of prepositions and pronominal objects of nouns.

24. The marginality of (111)c is due to the preference for having the subject as the $\overset{V}{\text{sel}}$ object in these configurations. See footnote 7 above for some discussion.

25. Note that the diagram in (112) gives only one possible derivation of (111)a. Another possibility is to generate the 'et phrase under \bar{N}_1 . The same holds for the diagram in (115), which gives only one structural representation of (114).

26. Clearly 'et phrases do not lend themselves to doubling in the way that $\overset{V}{\text{sel}}$ phrases do. In fact, doubling with 'et is impossible. Thus, in (115), \bar{N}'_2 cannot meet the Complement Matching Requirement, and if \bar{N}_3 is not generated the sentence is ruled out. It will be argued

below that 'et, unlike ^vsel, is available in the base. It is quite plausible to assume that since 'et is an accusative marker, its object cannot meet the Complement Matching Requirement of a genitive assigning head (for example, the head noun of the construct state).

27. Adjunction of dummy Case markers was proposed by Vergnaud (1974), Jaeggli (1980), Manzini (1981), Stowell (1981) and others.

28. One could argue that the structure in (120) should enter into the binding conditions since, although \bar{N} does not c-command herself in (118), \bar{N}' does. In chapter 3, section 3.3, some evidence will be presented that the latter hypothesis should be rejected. For discussion of some problematic cases, see Chapter 3, footnote 10.

29. One could argue that, in fact, (125)b is ungrammatical because it contains two instances of [e], only one of which can be properly governed: one instance of [e] is coindexed with the clitic (\bar{N}_3 in (115)), while the other is $[e]_i$. Note, however, that if the head, rather than the clitic, is the governor in (125)b, there is no a priori reason why it should not properly govern two empty categories. Furthermore, since under any plausible account the clitic will properly govern the empty position coindexed with it (although it might do so redundantly), why can't the head properly govern $[e]_i$ in (125)b? Thus, the presence of two empty categories in (125)b is, in fact, irrelevant for proper government by the clitic.

30. The contrast between (126)a and (126)b extends to the contrast between (i) and (ii) as well:

- (i) lo barur la-nu mi biker 'et ktivat ha-ma'amarim
 not clear to-us who criticized writing the articles
^vsel 'eize sofer
 of which writer
 'it is unclear to us who criticized the article-writing of which
 writer'
- (ii) *lo barur la-nu mi biker 'et ktivat Dan 'et 'eize ma'amarim
 'it is unclear to us who criticized Dan's writing of which articles'

Note, however, that, following the requirement of proper government of the extraction site, (i) should be ungrammatical as well, if only the WH in situ is fronted. However, we believe that another derivation is possible, in which the entire phrase 'writing the-articles of which writer' is pied-piped in logical form. In (ii), however, this derivation is blocked.

The availability of pied piping in (i), but not (ii), is confirmed by the grammaticality of syntactic pied piping in the former but not in the latter:

- (iii) 'et ktivat ha-ma'amarim ^vsel mi Dan biker?
 acc writing the-articles of who Dan criticized?
- (iv) *'et ktivat Ran 'et ma Dan biker?
 acc writing Ran acc what Dan criticized?

It has been pointed out to me by N. Chomsky (personal communication) that the availability of pied piping in (i) and (iii) and the ungrammaticality of (ii) and (iv) might follow from the clausal nature of (ii) and (iv) and the phrasal nature of (i) and (iii).

FOOTNOTES: APPENDIX TO CHAPTER 2

31. Recall that, in fact, \underline{V}_{sel} can be inserted preceding the empty category. In this case, however, its Case features will be spelled-out as a clitic, resulting in the construction in (1):

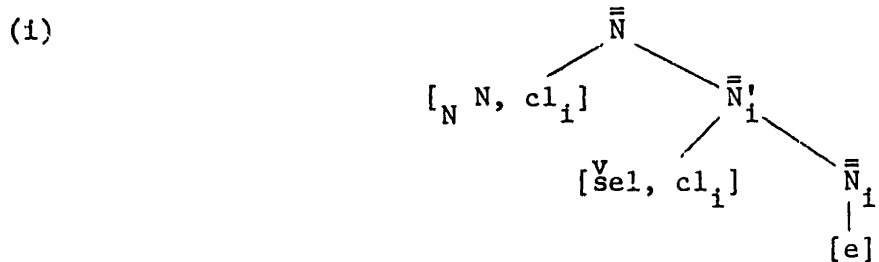

In (1) the clitic on \underline{V}_{sel} absorbs the Case features of \underline{V}_{sel} , and thus they cannot be assigned to \bar{N}_i anyway. See chapter 3, section 3.3 and footnote 6 for some discussion.

32. Note that the analysis of existential sentences as proposed in Stowell (1978) is entirely compatible with the θ -criterion. Assuming that the subject position of the verb be is not a θ -position, (as is evidenced, for instance, by the rule of passive, in which case an NP is fronted to this position), the movement advocated by Stowell is indeed from a θ -position to a non- θ -position, as follows from the θ -criterion (see chapter 1, section 1 for discussion). A rightward movement analysis, as argued for by Milsark (1974) and others, either violates the θ -criterion or would have to claim that there are (at least) two distinct be's: the one that does not have a θ -subject (passive) and the one that does have a θ -subject (existentials). For some more discussion of this point see Borer (1980a).

33. For a discussion of the lowering analysis with respect to Case assignment to variables, see Chomsky (1981). Chomsky notes that the analysis proposed by May supplies yet another distinction between PRO and trace. Only the latter (but not the former) can serve as a variable. Thus "quantifier lowering" interpretations are possible only in raising structures, where such a trace is available, but not in control structures, where the subject position of the infinitivals is occupied by PRO. Insofar as May's analysis verifies this aspect of the model it seems desirable to retain it.

34. For some discussion of exceptional Case assignment with respect to so-called "raising-to-object" verbs and other constructions see chapter 1, footnote 13 and references cited there.

35. By having ϕ features, empty elements such as PRO, NP-trace and variable differ from a null category. The latter is simply a non-expanded node which has no features at all. In chapter 4 below we return briefly to this distinction. The null category is marked in this work as [$_{X}$] where X is the non-expanded category.

36. A problem for the lowering analysis which we will not discuss here is the status of the empty category in the subject position of the matrix following the lowering. Note that this [e] will be governed, hence not a PRO, but it will not be properly governed, since AGR is not a proper governor (and see chapter 4 for some additional discussion). Hence, this [e] will violate the ECP. For a suggestion that this position is an expletive [e] and that expletive [e]'s are not subject to ECP, see Safir (1981).

CHAPTER 3: PARAMETRIC VARIATIONS IN CLITIC CONFIGURATIONS

1. Introduction

In chapter 2 we argued for a particular analysis of clitic configurations. That analysis was motivated by data from clitic-doubling configurations in Modern Hebrew. In this chapter I will try to extend the analysis presented above to various other clitic configurations. While some of these configurations will fit into the analysis proposed above without any additional machinery, others will show certain variations. It will be shown that by utilizing the restricted class of parameters outlined in chapter 1, these variations can be explained in a natural way.

Recall that in essence, we argued that in clitic-doubling configurations the clitic is best characterized as a spell-out of certain features on the head. It was further argued that rather than perceiving of the clitic as an independent nominal element, it should be viewed as a feature on the head. It follows that rather than representing the complex head+clitic as a branching complex (as suggested, for instance, by Rivas, 1977 and Jaeggli, 1980), it is best represented as a non-branching complex (more or less along the structural lines suggested by Kayne, 1975). From this representation it follows that if the head takes a nominal complement, the clitic cannot be viewed as satisfying this complementation requirement. Rather, an independent nominal node has to be generated in its regular position and this node satisfies the complementation requirements. Thus the structure of clitic doubling is as in (1):

(1)

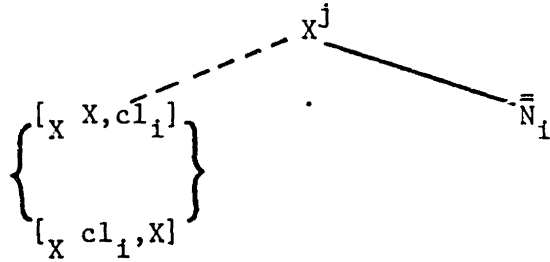

A large part of the previous chapter was dedicated to determining the relationship which holds between various elements in the structure illustrated by (1). We concluded that a relationship of coindexing holds obligatorily between the clitic and the \bar{N} complement. This obligatoriness stems precisely from the fact that the clitic does not satisfy thematic and syntactic requirements of the head: rather, the \bar{N} does. Under such an analysis, the obligatory coindexing between the clitic and the complement \bar{N} is reduced to the natural requirement that a thematic matrix cannot contain conflicting referential indices. This generalization was formulated as the Complement Matching Requirement. It was shown that the coindexing can hold only when the clitic (and the head on which it is a feature) governs the \bar{N} . Again, this state of affairs follows naturally from the assumption that government is the domain of complementation, or, in other words, that complementation entails government. Since the clitic is a feature on the head X and since \bar{N} in (1) is a complement of the head X , it follows that it has to be governed by the coindexed clitic. If \bar{N} is not governed by the clitic, \bar{N} cannot be perceived as satisfying the complementation requirements of X and hence the obligatory coindexing with the clitic does not hold.

A natural extension of the coindexing and the government relations between the clitic and \bar{N} is the relationship of proper government which

holds between the clitic and \bar{N} when \bar{N} dominates an empty category [e]. We argued that this relationship indeed holds, supporting our conclusion by demonstrating that extraction of \bar{N} is possible.

In this chapter, we will discuss variations in clitic configurations. The organization of this chapter will be as follows: in section 2 we will briefly discuss some general aspects of clitic constructions in some Romance languages where cliticization and clitic doubling is attested only in VP's. In particular, it will be shown that Rumanian and River Plate Spanish (RP Spanish), where clitic doubling is attested, obey Kayne's generalization in the sense discussed in chapter 1 above. In section 3 I will turn to clitic-doubling configurations in Rumanian. It will be shown that although Rumanian, like Hebrew, shows extraction from clitic-doubling configurations, a crucial difference in the distribution of such extraction follows from the different properties of the Case marker pe in Rumanian vs. the Case marker $\bar{S}el$ in Modern Hebrew. It will be shown that by restricting the level of the application of the $\bar{S}el$ insertion rule we can account for the differences between extraction in Rumanian and extraction in Modern Hebrew. Furthermore, some peculiar binding facts of Hebrew and Rumanian will be given a natural explanation assuming that parameters may restrict the level of the application of local rules, as we suggested in chapter 1 above. In section 4 we will discuss clitic configurations in RP Spanish. It will be shown that some aspects of cliticization in causative constructions can be explained if we assume that clitics have to govern the position which is coindexed with them. By explaining the distribution of clitics in these constructions, we will be supporting a particular

analysis of causative constructions. In that section it will be further indicated that there are some differences in extraction from clitic-doubling constructions between Rumanian and some dialects of RP Spanish. These differences, it will be argued, depend on the difference in Case-assignment properties between the marker a in RP Spanish and the marker pe in Rumanian. The discussion in this chapter will motivate a slight change in the definition of proper government. In addition, it will further clarify the nature of parametric variations as well as the nature of cliticization and clitic spell-out proposed above.

2. Clitic Doubling in Romance

We will discuss clitic configurations and clitic doubling as attested in two Romance languages: Rumanian (as described by Steriade, 1980) and RP Spanish (as described by Rivas, 1977 and Jaeggli, 1980). The basic paradigm of clitic and clitic-doubling cases in these languages is given in (2)-(3):

(2)a. lo_i vimos a Juan_i
 him saw-we to Juan
 'we saw Juan'

b. lo vimos
 him saw-we
 'we saw him'

(RP Spanish, Jaeggli, 1980)

(3)a. I_i-am văzut pe Popescu_i
 him-have-I seen OM Popescu (OM = Object Marker)
 'I have seen Popescu'

- b. l-am vǎzut
 him-have-I seen
 'I have seen him'

(Rumanian, Steriade, 1980)

(We return below in sections 3.2 and 3.3 to the nature of pe in (3)).

Both in Rumanian and in RP Spanish, clitic doubling is attested in certain environments which are semantically specified (and see sections 3 and 4 below for some discussion of these semantic conditions). Jaeggli observes that these environments in RP Spanish are a subset of the environments in which the preposition a is available (note, however, that this entailment works only in one direction: it is not the case that clitic doubling is possible whenever a is present, as is exemplified by (7)):

- (4)a. vimos a Juan
 saw-we to Juan
 'we saw Juan'
- b. *vimos Juan
- c. lo_i vimos a Juan
 him saw-we to Juan
 'we saw Juan'
- d. *lo_i vimos Juan_i
- (5)a. vimos una camisa
 saw-we a shirt
 'we saw a shirt'
- b. *vimos a una camisa
 to
- c. *la vimos una camisa

- d. *la vimos a una camisa
- (6)a. vimos a la camisa
to the
- b. vimos la camisa
- c. *la_i vimos a la camisa_i
- d. *la_i vimos la camisa_i
- (7)a. yo vi a alguien
I saw to someone
- b. *yo vi alguien
- c. *yo lo_i vi a alguien_i
- d. *yo lo_i vi alguien_i

The same is true for Rumanian, where the environments for clitic doubling constitute a subclass of the environments for the object marker pe. (However, in Rumanian clitic doubling is obligatory, while in RP Spanish it is optional but highly preferred):

- (8)a. l_i-am văzut pe Popescu_i
him-have-I seen pe Popescu
- b. *l_i-am văzut Popescu_i
- c. *am văzut pe Popescu
- (9)a. am văzut un bucătar
have-I seen a cook
'I have seen a cook'
- b. *am văzut pe un bucătar
have-I seen pe a cook
- c. *l_i-am văzut pe un bucătar_i¹
it-have-I seen pe a cook
'I have seen a cook'
- d. *l_i-am văzut un bucătar_i
it-have-I seen a cook

(10)a. am văzut pe altcineva
 somebody else

b. *am văzut altcineva

c. * l_i -am văzut pe altcineva $_i$

In view of Kayne's generalization (see chapter 2, (2) above) both the Rumanian and the RP Spanish data seem to lend themselves to an analysis in terms of clitic spell-out of Case features and the availability of an independent Case assigner: for both languages it would be plausible to argue that the clitic in sentences such as (4)c and (8)a absorbs Case. Consequently, the NP position, which the verb 'to see' in these two languages subcategorizes for, remains caseless. The availability in both these languages of an independent Case-marking device -- the preposition a in RP Spanish and the marker pe in Rumanian -- renders clitic doubling in these languages possible. Note, incidentally, that with respect to (4)c and (8)a the question of government by the coindexed clitic is rather trivial, since the V node in (11), the structure corresponding to (4)c and (8), governs the NP complement -- as does the clitic when it is attached to the verb:

(11)

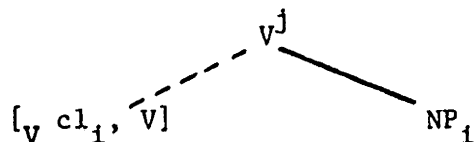

In spite of the obvious similarities between clitic-doubling constructions in Spanish and in Rumanian, there are some rather surprising differences between these configurations in the two languages: whereas in Rumanian, extraction from clitic-doubling configurations

- (13)a. $\left[\begin{array}{l} \text{-specific} \\ \text{-definite} \\ \text{+pronominal} \end{array} \right]$ caut pe altcineva
I-am-looking-for somebody else
- b. $\left[\begin{array}{l} \text{-specific} \\ \text{-definite} \\ \text{+human} \\ \text{-pronominal} \end{array} \right]$ caut un bucătar
I-am-looking-for a cook
- c. $\left[\begin{array}{l} \text{+specific} \\ \text{-human} \\ \text{-pronominal} \end{array} \right]$ am văzut cîinele lui Popescu
I-have seen the-dog of Popescu

As can be seen from (12), clitic doubling occurs only in the cases in which the NP direct object satisfies both requirements, namely, when it is [+human/pronominal] and [+specific/definite]. This is the case in (12) but not in (13). (Clitic doubling in Rumanian happens in indirect objects as well under certain conditions. These constructions, however, will not be discussed in detail here. For some discussion of dative clitics, see section 4.3.)

Clitic-doubling phenomena seem to occur in post-extraction configurations in Rumanian as well. As a generalization, it can be demonstrated that these clitics appear when the extracted object NP satisfies the [+specific/definite] requirements. This is shown in (14)-(16):

- (14)a. casa pe care credea*i* că am văzut-o ...
the-house which thought-you that have-I seen-her
- b. pe care credea*i* că am văzut-o?
 which-one thought-you that I-have seen-her
- (15)a. pe cine credea*i* că am văzut?
 who thought-you that I-have seen

b. *pe cine credeai că am văzut-o?
 who thought-you that I-have seen-her

(16)a. ce credeai că am văzut?
 what thought-you that I-have seen

b. *ce credeai că am văzut-o?
 what thought-you that I-have seen-it

With respect to the differences between (14) on the one hand and (15) and (16) on the other hand, Steriade states the following:

The difference between (6b) (=14) and (6c) (=15 and 16) is that in [(14)] the question word quantifies over a set of known membership... it is appropriate only in a context where the common background of the conversation includes the information that the referent of 'you' has seen at least one of a previously mentioned set of objects. One overt indication of this is that the ...clitic of a definite question like [(14)] agrees in gender with the NP that constitutes the previous mentioned set in question: thus from [(14)] we can gather that the set has been referred to by a noun whose grammatical gender is feminine.

This is obviously not the case for (15) and (16), where the set to which the questioned element belongs is not known and thus cannot be conceived as specific. It follows that only in (14) does clitic doubling take place, but not in (15) and (16).

Let us assume for a moment that the requirement for [+human/ pronominal] in these configurations is met by the WH word itself which is fronted to COMP and which is considered a pronominal element (but see discussion in section 3.4 below). Now let us turn to the analysis of the post-extraction configurations. Sentences (14)a-b seem at first glance to utilize a resumptive pronoun strategy. However, if one wished to advocate such an approach to these configurations in Rumanian, two serious problems would immediately present themselves: first, why is the resumptive pronoun strategy

available in precisely the same environment in which clitic doubling is allowed? The second question concerns the unavailability of subjacency violations in sentences such as (17):

- (17) *omul_j pe care_j o_i-cunosc pe femeia_i care_i t_i l_j-a
 the-man OM whom her-know-I OM the-woman who him-has
 întîlnit t_j a venit
 met has come
 'the man that I know the woman who met him came'

Ross (1967) observes that constructions which utilize the resumptive pronoun strategy can violate constraints on movement such as the Complex NP Constraint and the Island Constraint (subsumed by the subjacency principle of Chomsky, 1973). If the clitics in (14) above were a real manifestation of resumptive pronoun strategy in questions in Rumanian, we would expect (17) to be grammatical although it is a violation of the CNPC. Nevertheless, (17) is ungrammatical, as are, systematically, all other sentences which contain an antecedent and a clitic inside a Complex NP or an island. This seems to indicate that (14)a is generated by movement and not by a resumptive pronoun strategy.

On the other hand, the analysis proposed above for clitic doubling accounts in a straightforward way for the grammaticality of (14) on the one hand and the ungrammaticality of (15)b and (16)b and (17) on the other.

Recall that we proposed that the structure of clitic-doubling constructions is as follows:

(18)

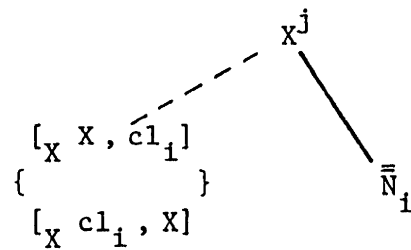

Further recall that we have been assuming that the clitic in (18) is a spell-out of the Case features of X, and that, as such, it "deprives" the complement NP of its Case. An independent device is needed in order to assign Case to that NP if it actually contains lexical material. Now let us assume that for Rumanian X is a verb and that pe, the direct object marker, is precisely the independent Case-assigning device we are looking for: it assigns Case to the complement NP if the Case features were spelled out as a clitic. Recall that we argued above that the \bar{N}_i position in (18) is a position from which extraction is possible and that indeed such extraction occurs in Modern Hebrew free relatives.

Now consider again the sentences in (14), (15) and (16). The fact that clitics can appear in post-movement configurations only when the extracted elements satisfy the semantic requirements of direct objects in clitic-doubling configurations is now explained entirely naturally: it follows from the fact that structures such as (18) are available only in clitic-doubling configurations: in these structures the clitic already exists alongside the extracted NP, thus permitting doubling in pre-extraction or post-extraction sentences.

Recall that we further argued above that the empty category which is left after the extraction of \bar{N}_i in configurations such as

(18) is properly governed by the coindexed, governing clitic. This analysis can be carried over to the Rumanian case since here as well we have a governing, coindexed element, the empty category is thus properly governed in a similar fashion. This situation is illustrated in (19):

(19)

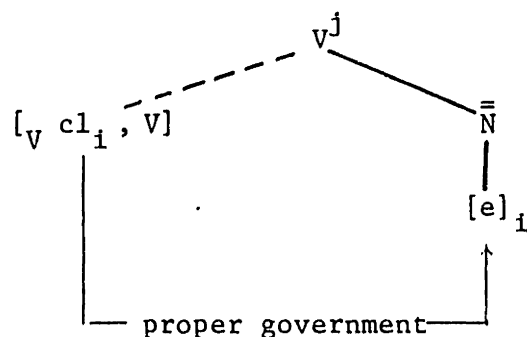

To summarize, the analysis of the Rumanian facts supports the analysis of clitic doubling that has been presented above: it was observed again that extraction from clitic-doubling constructions is possible, thus supporting an analysis of clitic doubling which advocates proper government of this position. Note that extraction in Rumanian is possible in non-clitic-doubling configurations, as is demonstrated by (15)a and (16)a. Thus we assume that in Rumanian as well verbs are proper governors. Given this, Rumanian cannot supply direct evidence for proper government by clitics. However, since the clitic clearly governs the coindexed NP position and is coindexed with it, it is unclear how such proper government could be blocked. We conclude that in the post-extraction configurations in Rumanian, the [e] is properly governed twice, i.e. redundantly.

3.2. On Differences in Extraction between Hebrew and Rumanian:

se_i vs pe

In section 3.1 above it was shown that extraction from clitic-doubling constructions in Rumanian is possible. In chapter 2 section 3, it was shown that in Modern Hebrew such extraction is possible as well. Recall, however, that we argued that in Modern Hebrew such extraction is only possible in free relatives. Thus in Modern Hebrew we have the following contrast:

- (20)a. kaniti ma_i ^vse-rašav^vt 'al-av_i [e]_i
 bought-I what that-thought-you about-it
 'I bought whatever you thought about'
- b. *^vša'alti ma_i xāšav^vt 'al-av_i [e]_i
 asked-I what thought-you about-it
 'I asked what you thought about'

The contrast between (20)a and (20)b was explained by utilizing the Case filter: note that since the clitic in both (20)a-b is a spell-out of the Case features of the preposition 'al 'about', the fronted WH element cannot receive Case from 'al. Assuming that the Case filter holds for WH elements (see chapter 1 and chapter 2, appendix) every fronting of WH elements from a non-Case position should result in ungrammaticality, unless an independent device is available to assign Case to the WH element. We argued that such a device is Case assignment into COMP of the type argued for by Groos and van Riemsdijk (1979), and it is available (in Modern Hebrew) for free relatives but not for questions. Consequently we expect the extraction from non-Case positions to be grammatical in free relatives but not in questions,

which is precisely the situation in (20). In questions, we argued, this state of affairs results in an obligatory pied-piping, since this is the only way in which the WH element can be Case marked and the [e] left behind does not violate ECP:

- (21) $\overset{V}{\text{ša'alti}}$ 'al ma xašavt $[\text{pp e}]$
 asked-I about what thought-you
 'I asked about what you thought'

Recall, however, that there was an important difference in Modern Hebrew between the examples in (20), in which the doubling construction is in a PP and cases in which doubling takes place in NP's; for the latter but not for the former, there is a rescuing device: $\overset{V}{\text{šel}}$ insertion. The availability of the Case marker $\overset{V}{\text{šel}}$ and the fact that it can be inserted preceding the NP complement in clitic-doubling configurations inside NP's enables actual doubling to surface in NP's but not in PP's:

- (22)a. beit ha-more
 house the-teacher(m)
 'the teacher's house'
- b. $\text{beit-o } \overset{V}{\text{šel}} \text{ ha-more}$
 'the teacher's house'
- c. * beit-o ha-more
- (23)a. 'al ha-more
 about the-teacher
- b. *'al-av ha-more
 about-him the-teacher

(23)b cannot be rescued, since Modern Hebrew does not have an independent device that could be inserted to assign Case to ha-more 'the-teacher'. Since the Case assignment properties of 'al are absorbed

by the clitic, (23)b violates the Case filter.

One could raise the question of whether, due to the availability of a Case assigner to the doubled NP in the construct state, we would expect the difference between questions and free relatives to disappear when extraction takes place from these constructions. However, the extraction from construct state NP's shows exactly the same distribution as extraction from PP's: questions are ungrammatical and free relatives are grammatical. In fact $\overset{v}{s}el$ cannot be extracted with the fronted WH, nor can it be left behind:

- (24)a. 'anaxnu 'ozrim le-kol mi_i $\overset{v}{s}e$ -beit-o_i [e]_i nisraf
 we help to-every who that-house-his burned
 'we help everyone whose house burned'
- b. * $\overset{v}{s}a$ 'alnu mi_i beit-o_i [e]_i nisraf
 asked-we who house-his burned
 'we asked whose house burned'
- c. * $\overset{v}{s}a$ 'alnu $\overset{v}{s}el$ mi_i beit-o_i [e]_i nisraf
 of
- d. * $\overset{v}{s}a$ 'alnu mi_i beit-o_i $\overset{v}{s}el$ [e]_i nisraf
 of

We explained the facts of (24) by arguing that the rule which inserts $\overset{v}{s}el$ operates in the phonological component and that the environment for its insertion is dependent upon string adjacency. The rule of $\overset{v}{s}el$ Insertion is repeated here as (25):

(25) $\overset{v}{s}el$ Insertion ($\check{S}I$)

$$\emptyset \longrightarrow \overset{v}{s}el / [_{NP_1} \dots \text{---} NP_j]$$

Since in (24)a-b the environment for \check{V}_{sel} Insertion is not met, \check{V}_{sel} is never inserted and the status of extraction from NP's is rendered equivalent to the status of extraction from PP's.

In Rumanian, however, there is no such difference between free relatives and questions. When the fronted WH element satisfies the semantic requirements for doubled objects, both are possible. Thus alongside (14)a-b we have (26) as a specific free relative in which doubling is possible, and alongside (15)a-b we have (27)a-b, demonstrating that when the free relative is non-specific doubling is blocked:

- (26) am v\u0103zut-o_i pe care_i credeai c\u0103 am v\u0103zut-o [e]_i
 have-I seen-her pe which-one thought-I that have-I seen-her
 'I have seen whichever person you thought I have seen'
- (27)a. am v\u0103zut pe cine_i credeai c\u0103 am v\u0103zut [e]_i
 have-I seen pe who thought-you that have-I seen
 'I have seen whoever you thought that I have seen'
- b. *am v\u0103zut-o_i pe cine_i credeai c\u0103 am v\u0103zut-o_i [e]_i
 have-I seen-her pe who thought-you that have-I seen-her
- (28)a. am v\u0103zut ce_i credeai c\u0103 am v\u0103zut [e]_i
 have-I seen what thought-you that have-I seen
 'I have seen whatever you thought that I have seen'
- b. *am v\u0103zut-o_i ce_i credeai c\u0103 am v\u0103zut-o_i [e]_i²
 have-I seen-_{her}{it} what thought-you that have-I seen-_{her}{it}

Note that the ungrammaticality of (28)b cannot be related to the unavailability of the marker pe in these configurations; in (27)b, pe is available, and nevertheless the sentence is ungrammatical. Again, this situation is completely parallel to that of (15)b above: there as well doubling was impossible, regardless of the existence of the marker pe.

The contrast between (15) and (27), in which pe appears, on the one hand, and (16) and (28), in which pe is absent, on the other hand, illustrates the environments in which pe is present but clitic doubling is impossible: pe is present preceding direct objects which satisfy all the requirements in (12) above. In addition to these environments, it appears preceding a direct object which is [+pronominal, -specific] and which is morphologically marked as [+human]. This latter requirement is demonstrated by the contrast between (29)a and (29)b:

- (29)a. caut pe altcineva
 I-am-looking-for pe somebody-else
- b. caut (*pe) altceva
 something-else

Let us assume that this environment is a homogeneous semantic class, characterized as [+P], and that pe contains the semantic features [+P]. We will further assume that as part of the interpretive component, the [+P] features of the marker pe are checked against the availability of these features in the NP object of pe. A [+P] marker adjoined to a [-P] object results in ungrammaticality. On the other hand, a [+P] direct object which is not marked by a [+P] marker is ruled out as well.³

The grammaticality of (15)a, (27)a and (29)a indicates that pe is available in environments which do not allow for clitic doubling and in which there is no need for an independent Case marker. Thus clearly the occurrences of pe in the grammar of Rumanian

cannot be accounted for solely by assuming a rule of pe insertion which operates in the phonological component and which assigns accusative Case to Caseless direct objects. Rather, it seems that clitic doubling in Rumanian direct object configurations is a "by-product" of the availability of an independently existing object marker. Recalling further that pe has [+P] semantic features and thus it must feed the interpretive component, it seems plausible to assume that pe is available at D-structure in the [+P] environments illustrated above, and that it has -- as one of its lexical specifications -- the property of assigning accusative Case to its complement. (For more detailed discussion, see section 3.3 below.) Let us further assume that accusative Case assignment by pe is obligatory.⁴

In essence, the obligatoriness of Case marking in the case of pe would entail that whenever an element X has Case features α , α must be realized phonologically, either as a clitic or on a phonetically realized NP. Further assuming that Case conflict leads to ungrammaticality, the accusative Case assignment features of pe will predict the ungrammaticality of pe occurrences in all environments in which an NP is otherwise marked for non-accusative Case:

- (30) *am dat cartea lui pe Popescu
 have-I given book to pe Popescu
 'I gave a book to Popescu'

In (30), Popescu is marked as dative by the preposition lui 'to', and an additional accusative marking by pe rules the sentence out. (Note that we are tacitly assuming that double assignment of the same Case does not lead to ungrammaticality. Thus, in (29)b, altcineva 'somebody else' is marked accusative twice: once by the verb and once by pe. There, is however, no reason to assume that such redundant marking is ungrammatical.)

The availability of pe in the base makes a clear prediction: we expect pe to be fronted alongside the NP which it precedes, and this prediction is confirmed. As we saw in (14)-(15) above, pe is indeed fronted with WH elements. Since pe is available when WH fronting occurs from clitic-doubling configurations such as (14)a-b, we expect such extraction to be entirely grammatical. Although the clitic absorbs the Case features of the verb, the WH element is nevertheless marked for Case by pe; hence, there is no need for an independent device marking Case into COMP. In this fashion we can account for the difference between Modern Hebrew and Rumanian: whereas in the former, š^vel is not available in the base, and hence cannot be fronted with WH elements, in the latter, pe is available, and hence we expect both questions and free relatives to be grammatical.

3.3. On the Insertion of Case Markers

In the previous section, we argued that š^vel differs from pe in that it is not available in the base and hence cannot function as a Case marker for fronted WH elements. We further argued that pe in

Rumanian is available in environments in which it clearly does not function as a "rescuing device" for the purposes of the Case filter. In Hebrew, on the other hand, there are no such cases: all occurrences of \underline{sel}^v , whether in clitic-doubling configurations or in other possessive constructions, fall under the generalization expressed by the environment in rule (25).⁵ All these factors favored the hypothesis that, whereas \underline{sel}^v is not available prior to the application of "Move α ", \underline{pe} is available at that stage.

In chapter 2, section 2.3 above, we argued that \underline{sel}^v phrases act as NP's with respect to the binding conditions (see (31)a). It was shown that they behave differently from objects of prepositions (as in (31)b) or from objects of an adjoined specificity marker (as in (31)c). (See section 4.2 for discussion.) It was argued that since, in \underline{sel}^v configurations, \underline{sel}^v insertion takes place in the phonological component, only in these cases (but not in the preposition cases or in the adjoined specificity marker cases) is the structure not branching, and it followed that the NP object of \underline{sel}^v can c-command a reflexive anaphor. A crucial assumption in our analysis was the claim that, in structures such as (32)c, \bar{N}_2 (and not \bar{N}'_2) is an A-position which enters into the binding conditions. The structure in (32)c, then, counts as a branching structure, and \bar{N}_2 cannot c-command elements outside its projection:

- (31)a. re'iyat 'acma₁ \underline{sel}^v ha-mora₁
 view herself of the-teacher
 'the teacher's view of herself'

b. *xašivat 'acma₁ 'al ha-mora₁
 thinking herself about the-teacher
 'the teacher's thinking about herself'

c. *re'iyat 'acma₁ 'et ha-mora₁
 view herself OM the-teacher OM = Object Marker
 'the teacher's view of herself'

(32)a. (= (31)a)

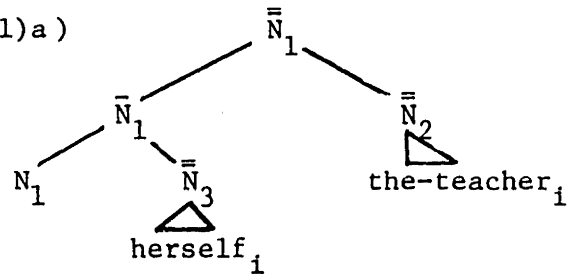

(sel is inserted in the phonology)

b. (= (31)b)

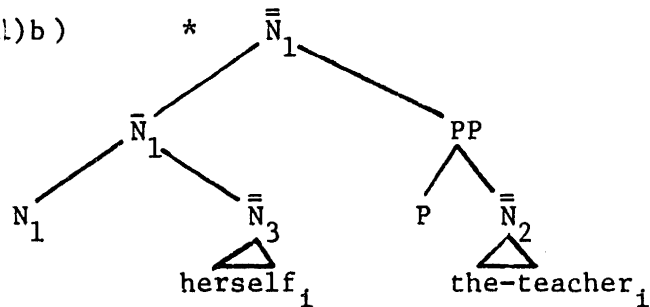

c. (= (31)c)

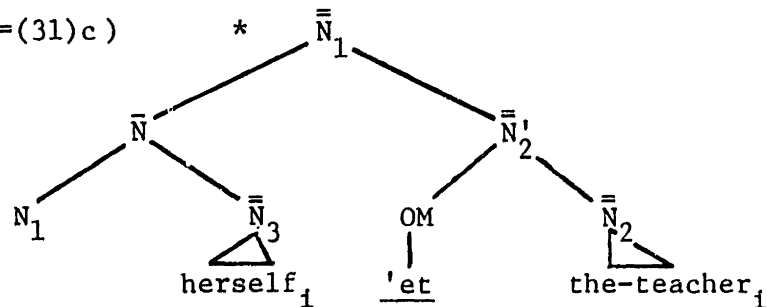

We argued for a theory of parameters in which language-specific variations were determined by the nature of local rules and by their mode of application. The definition of local rules is given in (33):

- (33) An operation that affects only a sequence of a single nonphrase node C and one adjacent constituent C' that is specified without a variable, such that the rule is not subject to any condition exterior to $C - C'$ (or $C' - C$) is called a local rule.

We assumed that C in (33) stands either for a grammatical formative or for a morphologically specified grammatical feature. With respect to (33), the following principle holds:

- (34) A local rule \underline{R} may apply at any level.

We further assumed that principle (34) is subject to parameterization in a particular way: the application of \underline{R} in a given grammar could be restricted from applying at certain levels. The pattern of such a parameter would be as in (35):

- (35) \underline{R} may not apply at level L .

(For detailed discussion of this proposal see chapter 1.)

An example of such a parameter is the pro-drop parameter discussed in Chomsky (1981) (and see chapter 4 for detailed discussion). We would like to argue that the insertion of dummy Case markers as well as the insertion of specificity markers is yet another instance of (34) and (35).

Given our analysis of $\overset{V}{\underline{sel}}$ and \underline{pe} so far, then, it would seem that $\overset{V}{\underline{sel}}$ is restricted to apply only in the phonology, and that \underline{pe} can apply only in the base. There is, however, some evidence that indicates that the correct formulation of the insertion of these two markers is less restricted. In the following two sections we will argue that the cor-

rect formulation of the restriction on $\overset{V}{\text{sel}}$ Insertion is as in (36), whereas the correct formulation of pe Insertion is entirely unrestricted; pe Insertion can indeed apply at any level, as formulated in (37):

(36) $\overset{V}{\text{sel}}$ Insertion ($\overset{V}{\text{SI}}$)

$$\emptyset \longrightarrow \overset{V}{\text{sel}} / [_{\text{NP}_1} \dots \text{---} \text{NP}_j]$$

Restriction: $\overset{V}{\text{SI}}$ may not apply in the base.

(37) pe Insertion (PI)

$$\emptyset \longrightarrow \text{pe} / [_{\text{VP}} \text{---} \text{NP}_j]$$

(PI is free to apply at any level at which insertion of grammatical formatives can apply: the base, S-structure or phonology.)

3.3.1. $\overset{V}{\text{sel}}$ Insertion at S-structure

Note that the evidence presented so far to the effect that $\overset{V}{\text{SI}}$ applies in the phonology ((31) and (32) above) is entirely compatible with the assumption that it may apply optionally either at S-structure or in the phonology. Note that only in the latter case would we have the structure in (32)a at S-structure, and thus only if -- in the case of (31)a and (32)a -- $\overset{V}{\text{SI}}$ applied in the phonology is the sentence grammatical. We could, however, assume that there is an alternative derivation which would yield a structure similar to that in (32)c, and that in this derivation (31)a is, in fact, ungrammatical, since $\bar{\text{N}}_2$ cannot be an antecedent of $\bar{\text{N}}_3$.

There is, however, some direct evidence that, in some cases, $\check{S}I$ must take place at S-structure. These are cases in which application of $\check{S}I$ in the phonological component would lead to ungrammaticality, due to independent factors, but where insertion at S-structure would result in grammaticality.

In chapter 2, footnote 5, we briefly mentioned that \check{sel} can itself take a clitic. This is illustrated in (38):

- (38) ha-xataltul \check{sel} -o / \check{sel} -a / \check{sel} -i etc.
 the kitten of-him / of-her / of-me
 'his / her / my kitten'

In chapter 2 and in the previous sections of chapter 3 we have advocated a certain view of clitics. According to this view, clitics should be regarded as a spell-out of Case features, which do not satisfy the requirement for an NP complement, if such a requirement exists. In view of this, a natural proposal for the structure of \check{sel} +clitic combinations should be identical to the structure proposed for combinations such as preposition+clitic. This structure is given in (39):

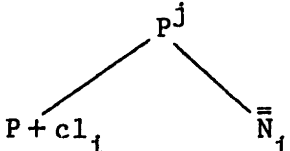
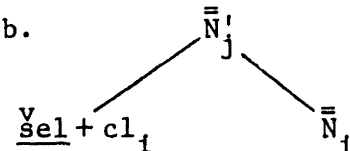
- (39)a.  b. 

(Recall that we are assuming that \check{sel} is adjoined to \bar{N} , as are specificity markers.)

For (39)a, we argued that the clitic is available at the LF component, since it can function as a proper governor for \bar{N}_1 if the latter

dominates an empty category. This analysis was used to account for the grammaticality of (40)a, as opposed to the ungrammaticality of (40)b. (See chapter 2, section 3 for detailed discussion.)

- (40)a. mi_i $\overset{V}{s}e-xa\overset{V}{s}avti$ 'al- av_i [e] $_i$
 who that-thought-I about-him
 'whoever I thought about'
- b. * mi_i $\overset{V}{s}e-xa\overset{V}{s}avti$ 'al [e] $_i$
 who that-thought-I about
 'whoever I thought about'

Since in Hebrew prepositions are not proper governors, only the availability of the clitic in (40)a makes extraction from PP's possible. Otherwise, the output structure, as in (40)b, is ruled out by the ECP.

If, indeed, (39)b is the right structure for $\overset{V}{s}el$ +clitic combinations, then we would expect the \bar{N}_i node in (39)b to be expanded as an empty category in cases such as (38) above, and in this case we would expect the coindexed clitic to properly govern this empty category. If it could be shown that the clitic adjoined to $\overset{V}{s}el$ does in fact properly govern an empty category, it will indicate that the clitic has to be present at LF, and hence, that it is also present at S-structure. Otherwise, it could not properly govern an empty category. Given that the clitic is a spell-out of the Case features of $\overset{V}{s}el$, its existence at S-structure would indicate that $\overset{V}{s}el$ itself is present at S-structure.

Testing whether (39)b is the right structure for $\overset{V}{s}el$ +clitic configurations can be achieved by extraction from \bar{N}_i when the clitic is present. If such extraction is possible, it would indicate that the

$\check{S}el$ in $\check{S}el$ +clitic configurations is present at S-structure. And, as indicated by (41)a, extraction from the \bar{N} position in the $\check{S}el$ +clitic configuration is indeed possible. (That proper government in this case is not by $\check{S}el$ itself or by the head N is demonstrated by the ungrammaticality of (41)b-c.)

- (41)a. 'anaxnu 'ozrim le-kol mi_i $\check{S}e$ -ha-bayit $\check{S}el$ -o_i [e]_i nisraf
 we help to-all who that-the-house of-his burned
 'we help everybody whose house was burned'
- b. *'anaxnu 'ozrim le-kol mi_i $\check{S}e$ -ha-bayit $\check{S}el$ [e]_i nisraf
 that-the-house of burned
- c. *'anaxnu 'ozrim le-kol mi_i $\check{S}e$ -ha-bayit [e]_i nisraf
 that-the-house burned

Thus, we conclude that when a $\check{S}el$ +clitic configuration appears, $\check{S}I$ has applied at S-structure. Note that if we were to assume in this case that $\check{S}I$ applied in the phonology, we would have the following structure at S-structure:

(42) (= (41)c)

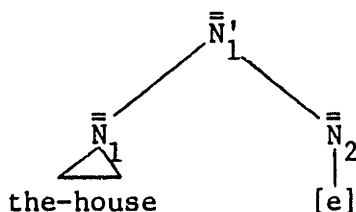

In (42), $\check{S}I$ could still apply in the phonology, and since the Case features of $\check{S}el$ have to be phonologically realized, we would still derive at PF the combination $\check{S}el$ +clitic. However, in this case, the empty category in (42) will not be properly governed, since the spelling out of the clitic at PF would not affect the application of the ECP, and \bar{N}_1 cannot properly govern \bar{N}_2 , as is demonstrated by (41)c. (This

situation contrasts sharply with the situation in which N_1 itself takes a clitic. In this situation, resulting in the grammatical 'house-his_i [e]_i' combination described in chapter 2 above, the clitic itself properly governs [e]_i.)

Given the optional application of $\bar{S}I$ at S-structure or in the phonological component, we expect the combination $\bar{S}el + NP$ to be either branching (in the sense of (32)c), or non-branching (in the sense of (32'a)). Only in the latter cases, however, can the object of $\bar{S}el$ (\bar{N}_2) serve as antecedent for a reflexive anaphor (\bar{N}_3) outside its own maximal projection. On the other hand, the combination $\bar{S}el + \text{clitic}$ can only be a branching one: a non-branching combination would yield a structure such as (42), in which an empty category is not properly governed.

Since $\bar{S}el + \text{clitic}$ combinations are always branching, we do not expect the empty category in structures such as (39)b to serve as an antecedent for a reflexive anaphor: we expect that the $\bar{S}el + \text{clitic}$ counterpart of (31)a would be ungrammatical, and, indeed, it is:

(43) *re'iyat 'acma_i $\bar{S}el-a_i$ [e]_i
 view herself of-her
 'her view of herself'

Note that the rather puzzling contrast between (43) and (31)a is explained in a straightforward way if we assume that only in (43), but not in (31)a, the $\bar{S}el$ phrase is branching. This branching structure, which is independently needed to supply a proper governor for an empty category, has the effect of blocking the [e]_i node in (43) from serving as an antecedent for a reflexive anaphor. The grammatical

way to express the phrase 'her view of herself' is as in (44), in which there is no anaphoric expression requiring an antecedent:⁶

- (44) ha-re'iya ha-'acmit $\overset{v}{s}el-a_i$ [e]_i
 the-view the-self of-her
 'her self view'

Let us conclude: we have argued that $\overset{v}{S}I$ can apply either at S-structure or in the phonological component. In the former case, the $\overset{v}{s}el$ object cannot serve as an antecedent for a reflexive anaphor outside its own maximal projection, but in the latter case the object of $\overset{v}{s}el$ behaves as a regular NP and can serve as an antecedent for a reflexive anaphor. This difference stemmed from the fact that when $\overset{v}{S}I$ applies in the phonology the structure is considered non-branching, whereas when $\overset{v}{S}I$ applies at S-structure it creates a branching structure, thus preventing its object from c-commanding elements outside its maximal projection. When a clitic is adjoined to the $\overset{v}{s}el$, $\overset{v}{S}I$ has to apply at S-structure. Its failure to apply at S-structure would result in the structure in (42), in which an empty category is not properly governed. It follows that when a clitic is adjoined to $\overset{v}{s}el$ the structure is always branching, and the empty category can never serve as an antecedent for a reflexive anaphor. We thus conclude that the correct formulation of $\overset{v}{S}I$ is as in (36) above: rather than restrict $\overset{v}{S}I$ to apply only in the phonological component, we took $\overset{v}{S}I$ to be a local rule whose application is blocked at the base.

3.3.2. Free Application of pe Insertion

In this section, we will show that the best characterization of the insertion of pe is as a rule free to apply at any level where the insertion of grammatical formatives is possible: in the base, at S-structure, and in the phonological component.

Recall that in section 3.2 above we showed that the fronting of pe along with fronted WH elements indicates that it has to appear in the base. Note, however, that our treatment of the fronting of pe in Rumanian is entirely compatible with the assumption that pe is inserted in the base optionally, rather than obligatorily. Consider again the cases of fronting of pe along with a WH element, as in (14)b above, repeated here as (45):

- (45) pe care_i credeai că am văzut-o_i ?
pe which-one believe-you that have-I seen-her_i
 'who do you believe I saw?'

Now let us assume that, in (45), pe insertion in the base is optional. It is clear, however, that if "Move WH" applied before pe insertion, the fronted WH element would no longer be able to receive Case, since it would no longer be in the environment of [_{VP} ___ NP], in which pe is inserted. Thus, PI is effectively forced to apply in the base for (45) to be grammatical, but we do not have to assume that it obligatorily applies in the base. The derivation in which it does not apply in the base is independently ruled out by the Case filter. Note that after the extraction pe can still be inserted preceding the empty category. However, since the Case features of pe, like the Case features of sel_V,

have to be phonologically realized, and since pe does not take a clitic (and, in fact, no non-verbal elements in Romance ever do), it can be inserted only in front of phonologically realized NP's, since only in this case will its Case features be realized.

Now let us consider the situation in free relatives in Rumanian. The relevant sentence, (26), is reproduced here as (46):

- (46) am v̄zut-o_i pe care_i credea_i c̄ă am v̄zut-o_i [e]
 have-I seen-him pe which-one thought-you that have-I seen-her
 'I have seen whoever you thought I have seen'

Note that if we argued that pe is consistently inserted in the base, we would expect two pe's to appear in (46): the first pe resulting from the specificity and [+human] value of the free relative itself and the second one resulting from the fronting of a [+specific, +human] direct object.

Rather than stipulating that a sequence pe pe is reduced to one pe, we would like to argue that one of these pe's is simply not inserted. Since the matching effect requires that the free relative, as an NP, will satisfy the same categorial requirements and the same semantic requirements as the gap, it follows immediately that one pe, inserted preceding the WH element in (46), suffices. This pe can be inserted in the base in the matrix only, inserted in the base preceding the WH element (prior to fronting of pe+WH) only, or, alternatively, inserted before the free relative constituent at a later point of the derivation. Since the post-extraction configuration in free relatives (but not in questions) satisfies the environment for PI, we

can assume that, indeed, in this case PI is free to apply at the base, at S-structure or in the phonological component.

Recall now that pe has certain semantic features, previously marked as [+P]. We clearly have to represent these semantic features in the interpretive component. Given that these features have to be represented, we would expect pe to be always present at S-structure. In other words, we would expect pe to be inserted in the base or at S-structure, but never in the phonological component, unless [+P] is represented in LF in some other way.

Recall that we argued that insertion prior to the phonological component would yield a branching structure, thus blocking the object of the inserted formative from serving as the antecedent to lexical anaphors outside its maximal projection. This claim makes it possible for us to test whether pe is inserted at S-structure or in the phonological component: if it is inserted at S-structure, we would expect its object to be restricted and not to be able to serve as an antecedent for a reflexive anaphor outside its maximal projection. If, on the other hand, pe insertion can take place in the phonological component, we expect the object of pe to be able to function as an antecedent for a lexical anaphor.

Now recall that we have in Rumanian three kinds of direct objects with respect to pe: the kind which is not marked at all by pe (exemplified in (47)a), the kind which was marked by pe but in which there is no doubling (exemplified by (47)b), and the kind in which there is pe and there is doubling, (exemplified by (47)c):

- (47)a. Ion a arătat fetița publicului
 John has shown the-girl to-the-public
- b. am văzut pe altcineva
 have-I seen pe somebody else
 'I have seen somebody else'
- c. Ion a arătat-o₁ pe fetița₁ publicului ⁷
 John has shown-her pe the-girl to-the-public
 'John showed the girl to the public'

Recall that doubling is a subclass of the cases in which pe occurs. This subclass satisfies [+P] and is further [+specific/definite], [+human/pronominal]. Assuming that PI can freely apply either at the base, at S-structure or in the phonological component, and assuming further that if it applies prior to the phonological component, its structure interacts with the binding conditions as a branching structure, our proposal makes a clear prediction: we predict that in cases such as (47)a the direct object can serve as an antecedent for a reflexive anaphor. Since there is no pe insertion, the structure never branches. In (47)b, however, the application of PI in the phonology will result in not representing [+P] in LF. We assume that this situation will result in ungrammaticality due to independent interpretative considerations, thus effectively forcing PI in these cases to apply either in the base or at S-structure. We thus expect the object of pe in (47)b never to function as an antecedent for a reflexive anaphor, since it will always be part of a branching structure at S-structure.

The situation in (47)c, however, is somewhat different. Here [+P] is represented both by pe and by the doubled clitic, since all

cases of clitic doubling are a subset of [+P] cases. Thus, in these cases, if PI applies in the phonology, the required [+P] information is still represented in LF by the doubled clitic. In these cases, we expect the application of PI in the phonology to be grammatical as well and we expect the object of pe in (47)c to function as an antecedent of a lexical anaphor. This situation will occur whenever PI applies in PF and thus there is no branching structure at S-structure.

These predictions are, indeed, verified: the object in (47)a can serve as an antecedent, the object in (47)b cannot and the object in (47)c can. These respective configurations are represented in (48)a-c:⁸

- (48)a. Ion a arătat fetița_i ei_i î[^]nșiși_i în oglindă
 John has shown the-girl her/dat her/emphatic in mirror
 dat
 'John showed the girl to herself in the mirror'
- b. *Ion a arătat pe altcineva_i lui_i î[^]nsuși în oglindă
 John has shown pe somebody else him/dat him/emphatic in mirror
 dat
 'John showed somebody else to himself in the mirror'
- c. Ion a arătat-o_i pe fetița_i ei_i î[^]nșiși_i în oglindă
 John has shown-her pe the-girl her her/emphatic in mirror
 'John has shown the girl to herself in the mirror'

One could argue that perhaps the ungrammaticality of (48)b is due to the fact that altcineva 'somebody else' cannot serve as an antecedent for a reflexive anaphor. Presumably, its lack of specificity would contrast with the specification of gender on the reflexive pronoun. However, when altcineva controls a PRO (which is in a non-branching

configuration), this PRO, although it is equally non-specific, can serve as an antecedent for a reflexive anaphor. This situation is demonstrated in (49):

- (49) Ion a văzut pe altcineva₁ PRO₁ vorbind cu el însuși₁
 John has seen pe somebody else talking to him him/emphatic
 'John saw somebody else talking to himself'

Interestingly, when a pe phrase is fronted from a non-doubling position, it leaves behind an empty category which no longer contains a branching structure. Thus, in these cases as well, we expect the occurrence of a lexical anaphor which is understood to corefer with the object of pe. Although pe is inserted in the base, the antecedent for the reflexive anaphor is not the object of pe itself, but the variable which is coindexed with it and which is not branching. And, indeed, in these situations, coreference between [e]₁ and the reflexive pronoun in (50) is grammatical:

- (50) pe cine₁ credeai că Ion a arătat [e]₁ lui₁ însuși₁
pe who thought-you that John has shown [e]₁ him₁ him/emphatic
 in oglinda?
 in the-mirror
 'who did you think that John showed to himself in the mirror?'

We conclude that pe, in fact, can be inserted at any level: at the base, at S-structure, and in the phonological component.⁹ The failure of PI to apply at any of these given levels will bring about the exclusion of certain configurations for which the application of PI at a given level is crucial. Thus, if PI failed to apply in the base, a fronted WH element in questions could not receive Case, resulting

in ungrammaticality. Effectively, then, PI has to apply in the base for structures in which 'Move WH' applies. On the other hand, it has to apply at S-structure in configurations which do not contain any other way to render in LF the [+P] features associated with the direct object. These are precisely the cases in which there is no doubling, but pe precedes the direct object nevertheless: only in these cases does pe contain crucial semantic information, which cannot be deduced otherwise. However, when pe co-occurs with doubling configurations, the [+P] information is obtained by the doubled clitic, since clitic-doubling cases are a proper subset of pe-insertion cases. In doubling constructions, then, pe insertion is free to apply in the phonological component. Since only in cases which contain pe but no doubling has PI to apply at S-structure, we expect that, in these cases only, the object of pe could not serve as an antecedent for a reflexive anaphor: PI at S-structure results in a branching structure. And, in fact, this is indeed correct: in these cases only, altcineva 'somebody else' in (48)b cannot serve as an antecedent.¹⁰

3.4. Nominal Pied-Piping in Rumanian

In section 3.1 above, it was argued that in extraction from clitic-doubling configurations in Rumanian, the WH element itself, the fronted element, served as an environment for clitic doubling. Note that this analysis supports a mechanism that will check the appropriateness of clitic doubling in the base: under such an analysis, the environment for clitic doubling is only met in the base and not, say, in LF.

Recall that we assumed that the rule which spells out various features as clitics (clitic spell-out of chapter 1) is a local rule and as such, we would like to argue that it can apply freely at any level. Since it is a local rule, we do not expect it to be sensitive to factors such as semantic environment.

Further recall that while discussing cliticization to $\bar{S}el$ we assumed that, for $\bar{S}el$, clitic spell-out applies at S-structure. In the base, $\bar{S}el$ is never present, since $\bar{S}I$ cannot apply at the base (see (36) above).

Thus it would be desirable to argue that clitic spell-out can occur at any stage, freely and optionally, regardless of its semantic environment. Mechanisms which are independently motivated in the grammar would then check the spelling-out of the clitic for appropriateness. Such mechanisms are semantic requirements checked in LF (as we assume to be the case in Rumanian), proper government and violations of ECP (as in the case of clitic spell-out in Hebrew) or the Complement Matching Requirement discussed in chapter 1.

In this section, we will present some evidence that will indicate that this characterization of clitic spell-out is the right one: it will be shown that the semantic requirements for clitic doubling are checked at a late stage of the derivation, such as LF, and that these semantic requirements should not be viewed as a triggering environment at any particular stage: rather, they should be viewed as well-formedness conditions on interpretation.

Steriade (1980) argues very convincingly that although at first

glance it seems that the WH element satisfies the semantic requirements for doubling prior to its extraction, this is in fact not correct. The cases which she cites as counterexamples to this statement are cases of nominal pied-piping. In these cases, the constituent as a whole does not satisfy the semantic requirements for doubling, and hence, if it is not extracted, it does not trigger doubling. However, the WH element inside the nominal expression satisfies these semantic requirements. The relevant case is given in (51):

- (51)a. Popescu mi- a comunicat rezultatele studiului său
 Popescu to-me has communicated the-results of-study his
 'Popescu communicated to me the results of his study'
- b. un studiu_j [ale cărui_j rezultate]_i mi le_i-a comunicat [e]_i Popescu
 a study whose results to-me them-has communicated P
 'a study whose results Popescu has communicated to me'

Note that in (51)a we do not have clitic doubling. The reason is that the NP rezultatele studiului său 'the result of his study' does not satisfy the semantic requirements for clitic doubling: although it is definite, it is neither human nor pronominal, and hence doubling is blocked. However, in the extraction construction corresponding to (51)a, (51)b, such doubling is attested and is in fact obligatory. A failure to have a clitic in these cases would result in ungrammaticality.

Steriade suggests that the requirement for clitic doubling in these post-extraction cases can be expressed if we assume that, rather than the fronted WH element, it is the trace left behind which has to satisfy the semantic requirements for doubling. In order to enable the trace left behind to satisfy these requirements, she proposes a

rule of shadow pronoun copying, essentially following proposals of Perlmutter (1972). Note that if, indeed, the trace can be perceived as pronominal, and if we assume that this trace retains the specificity feature of its antecedent, ale cărui rezultate 'whose results', then it will satisfy the semantic requirements for clitic doubling.

In essence, we will adopt this analysis here: with Steriade, we will assume that, indeed, semantic requirements on clitic doubling are checked on S-structure configurations. We will assume that there is a mechanism at LF which fails to assign interpretation to clitic-doubling configurations, unless the semantic requirements are met. We will deviate from Steriade's analysis only in one point: rather than assuming that there is a rule of shadow pronoun copying which assigns pronominal features to the trace of WH movement, we will assume that the relevant semantic features for clitic-doubling are inherently present: we assume with Chomsky (1981) that traces are marked for features such as person, gender and number. It is this specification which enables them to be perceived as satisfying the requirements for clitic doubling rather than the pronominal feature. In fact, let us assume that for pronominal elements as well the relevant semantic requirement is the presence of all and only the features number, gender and person, and that the disjunction [+human/+pronominal] should be replaced by the disjunction [+human/ α number, β gender, γ person].¹¹

Let us sum up at this point our discussion of clitic doubling in Rumanian. It has been shown that the Rumanian phenomena fit

naturally into the analysis proposed for clitic doubling in chapter 2 above. Furthermore, it has been shown that, insofar as our analysis can explain extraction from clitic-doubling constructions in Rumanian, Rumanian supplies evidence for this analysis.

While discussing the differences in extraction configurations between Rumanian and Modern Hebrew, we pointed out that these differences can be explained by utilizing the properties of the grammatical formatives $\bar{s}el$ and pe . It was suggested that the insertion of these formatives is the output of a local rule (in the sense of Emonds, 1976) and that this local rule can be parametrized by being restricted to apply at certain levels but not at others. Thus $\bar{S}I$ was restricted to apply either at S-structure or in PF but not in the base, whereas PI was not restricted and could apply either at the base, at S-structure or in PF. Independent components of the grammar, however, forced PI and $\bar{S}I$ to apply in certain levels rather than in others in order to yield a well-formed derivation. In these cases, we expected different structural properties resulting from the different levels of the application of PI and $\bar{S}I$ and, indeed, these structural properties were confirmed.

Our last section dealt with the status of the semantic requirements on clitic doubling: it was shown that these requirements are best characterized as a mechanism that applies after the application of movement rules and thus we assume that it is located in the interpretive component: LF. In effect, locating this mechanism in LF allows us a free spell-out of Case features (where such exist): other mechanisms

will rule out ill-formed outputs in a later stage of the derivation. Such mechanisms are ECP (as in the cases of [e] which are not properly governed) or semantic constraints. We will return to other mechanisms ruling out ill-formed outputs later.¹²

4. Clitics in River Plate Spanish

Clitic doubling in RP Spanish shows a great deal of similarity to clitic doubling in Rumanian. As in Rumanian, it has to obey certain semantic restrictions. Those semantic restrictions are, however, somewhat different. Moreover, although clitic doubling is preferred in environments which satisfy the semantic requirements, it is not obligatory. The following is a description of the semantic environment of clitic doubling in direct and indirect objects following Jaeggli (1980):¹³

(52) Indirect Objects

Non-Pronominal

- | | |
|---------------|------------|
| a. Goal i.o. | preferred |
| b. Poss. i.o. | obligatory |
| c. Pronominal | obligatory |

Direct Objects

Non-Pronominal

- | | |
|-------------------------|------------|
| d. Inanimate | impossible |
| e. Animate,
specific | preferred |
| f. Pronominal | obligatory |

(53)a.(=52a) Miguelito le_i regaló un caramelo a Mafalda $_i$
 Miguelito her-dat gave a candy to Mafalda
 'Miguelito gave a piece of candy to Mafalda'

b.(=52b) le_i duele la cabeza a Mafalda $_i$
 her-dat hurts the head to Mafalda
 'Mafalda has a headache'

- c.(=52c) le_i entregué la carta a él_i
 him-dat delivered-I the letter to him
 'I delivered the letter to him'
- d.(=52d) i. vimos la casa de Mafalda
 we saw the house of Mafalda
- ii. *la_i vimos la casa de Mafalda
- e.(=52e) lo_i vimos a Juan_i
 him-acc saw-we to Juan
- f.(=52) lo_i vi a él_i
 him-acc I saw to him

In this section we will discuss two phenomena related to clitics in RP Spanish. In subsection 4.1 below we will briefly outline an analysis of clitics in "two-storey" constructions in RP Spanish: causative constructions and 'permit' type verbs (indirect object control verbs). It will be shown that the distribution of clitics in these constructions can be explained quite naturally if we assume, as we argued for Modern Hebrew, that the clitic has to govern the NP position with which it is coindexed, in order for this coindexing to be grammatical. By explaining the distribution of clitics using a mechanism that is otherwise motivated, we will also support a particular analysis of causative constructions and 'permit' constructions. In subsection 4.2 we will discuss extraction facts in RP Spanish. It will be shown that, unlike Rumanian, from which RP Spanish minimally differs, some dialects of the latter do not allow for extraction from direct object position in clitic-doubling constructions. It will be shown that the difference in extraction between the two languages follows from the fact that in RP Spanish a can be a dative marker whereas

pe in Rumanian is always an accusative marker. In section 4.3 we will discuss dative clitics. It will be suggested that a rule of dative marking accounts for the availability of clitic-doubling in indirect object configurations in RP Spanish, but not in French. We will further show that the properties of the inalienable possessive constructions can be captured naturally, assuming the Complement Matching Requirement.

4.1 Clitic Government and 'Two-Storey' Constructions

In this section we will consider the nature of the government relationship between the clitic and the coindexed NP position. It will be shown that this relationship plays a crucial role in determining the clitic distribution in "two-storey" constructions in RP Spanish.

Recall that the structures that serve as a crucial test for the government requirement in the construct state in Modern Hebrew had the structure in (54):

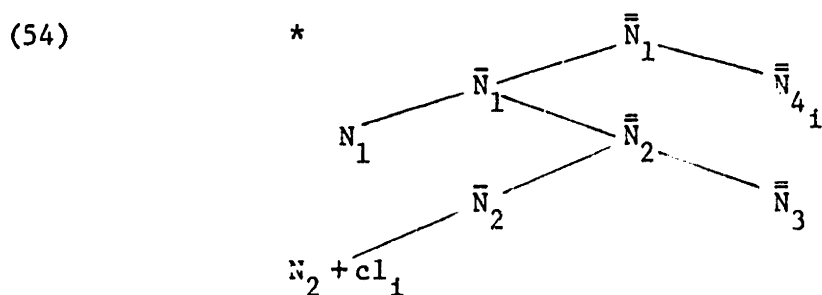

We argued that, in (54), N_2 and the clitic attached to it cannot govern \bar{N}_4 . This was based on the definition of government and c-command suggested in chapter 2, (42) and (53) above. In essence, those definitions entailed that government from the head position is only possible in the domain of the head, i.e., inside a maximal projection. Since in (54) \bar{N}_4 is not

in the domain of the head N_2 , it cannot be governed by it.

Can it be argued that when clitics are attached to verbs rather than nouns they exhibit the same government properties? The structure equivalent to (54) in the Romance languages would be as in (55):

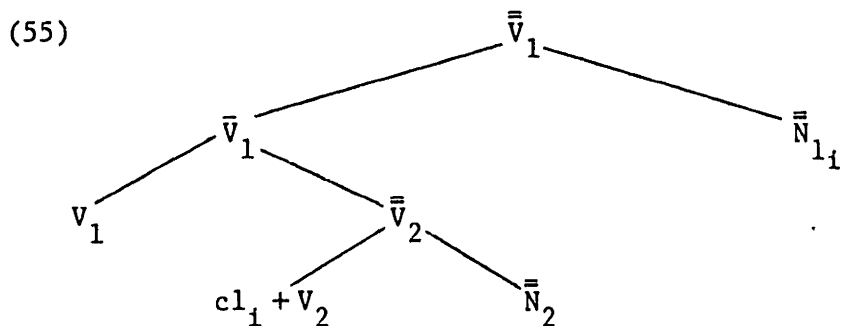

The structure in (55) is not attested in Romance languages. It could be argued, however, that the derived structure of causative constructions and other "two-storey" constructions in Romance languages exhibits government properties which are relevant to our claim about government by clitics. The sentences we have in mind in RP Spanish are as in (56) (the data from RP Spanish in this section is from Rivas, 1977):

- (56)a. María (le_i) hizo tocar la flauta a José_i
 María him-dat made play the flute to Jose
 'Maria made Jose play the flute'
- b. María (lo_i) hizo venir a José_i
 María him-acc made come to Jose
 'Maria made Jose come'

Let us first clarify some of the properties of (56)a-b. Note that in (56)a the clitic which corresponds to the subject of tocar

'play' is dative, whereas in (56)b the clitic which corresponds to the subject of venir 'come' is accusative. Since both clitics appear in an environment in which clitic doubling is not obligatory, they are optional. Note that, although both in (56)a and (56)b José is preceded by a, these a's are quite different. Whereas in (56)a the a is the regular dative a (and hence the corresponding clitic is dative), in (56)b the a is the object marker a discussed briefly in section 2 above. We will return to the distinction between these two a's in section 4.2 below.

It has been suggested by many scholars that the derivation of causative constructions in Romance involves the fronting of elements from a subordinate clause (to name only a few: Kayne, 1969, 1975; Aissen, 1974; Quicoli, 1976; Rivas, 1977; Rouveret and Vergnaud, 1980; Zubizarreta, 1979a,b; Burzio, 1981). Following these proposals, we will take the underlying structure of sentences such as (56)a-b to be roughly as in (56)c:

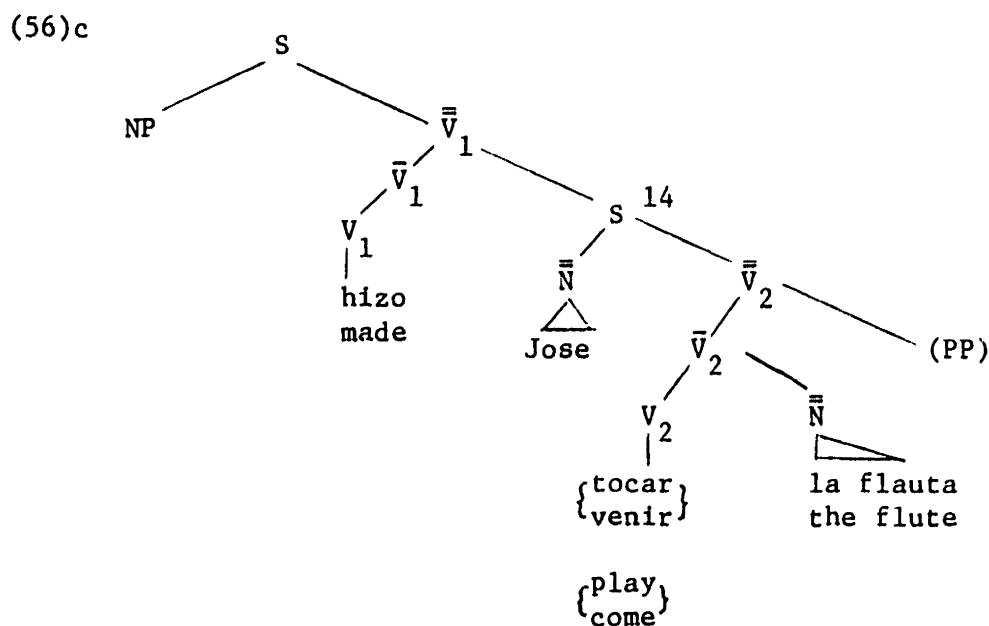

These scholars vary, however, with respect to the nature of the fronting which takes place in causatives.

Rivas (1977) shows that in RP Spanish, whenever fronting takes place, the verb must be fronted along with the complements which it strictly subcategorizes for. This situation is illustrated by the following paradigm:

- (57)a. María le_i hizo tocar la flauta a José_i
 'Maria made Jose play the flute' (accusative complement)
- b. María le_i hizo escribirles_j (una carta) a los chicos_j a José_i¹⁵
 'Maria made Jose write a letter to the children'
 (dative complement and optional accusative complement)
- c. María le_i hizo arrojar papeles en el cesto a José_i
 'Maria made Jose throw papers into the basket'
 (accusative and dative complements)
- (58)a. María (lo_i) hizo salir a José_i de la habitación
 'Maria made Jose leave the room'
 (non-strictly subcategorized complement)
- b. María (le_i) hizo tocar la flauta a José_i en la cocina
 'Maria made Jose play the flute in the kitchen'
 (strictly subcategorized complement vs. non-strictly subcategorized complement)

Recall that we argued that the domain of complementation is the domain of government by the head. It follows that whenever the verb strictly subcategorizes for a complement, whether accusative or dative, it has to govern it. Thus it is clear that whenever a verb strictly subcategorizes for a complement, any movement operation which results in the destruction of the government relationship between the verb and its complement will yield an ungrammatical sentence. Given our assumption that government relationships as well as the Complement Matching

Requirements are checked at S-structure, it follows that if the verb in causative constructions is fronted without any of its strictly subcategorized complements, the sentence will result in ungrammaticality.¹⁶

In this fashion, we would like to capture the obligatoriness of the fronting of all subcategorized complements attested in (57)a-c. (Note that this account will not explain the unavailability of fronting for non-strictly subcategorized complements. We will return to this matter below).

Let us then assume with Rouveret and Vergnaud (1980) that any projection of V_2 in (56)c can be fronted. Following Rivas (1977) we will suppose that v_2^j is adjoined to \bar{V}_1 -- i.e. to the \bar{V} projection of the matrix verb. We will further assume that subcategorized PP's can be generated under \bar{V} or under $\bar{\bar{V}}$, since in both cases they will be governed by the head.¹⁷ Given the requirement that in any configuration the verb will govern the complements which it strictly subcategorizes for, it follows that although the fronting of any projection of V_2 is possible, only those fronting operations which will not split the verb and its complement will result in grammaticality. Thus for (57)b, which is base-generated as (59)a or as (59)b, the only grammatical derivations are those in which both the direct object and the indirect object are fronted. Since we assume that PP can be dominated either by $\bar{\bar{V}}$ or by \bar{V} , there are two possible derivations of (59): the one in which $\bar{\bar{V}}$ is fronted and the one in which \bar{V} is fronted and it contains the PP. These two derivations are given in (60)a-b. (60)c is an example of an impossible derivation:

This is illustrated by (61)-(62):¹⁸

(61)a. Pedro (le_i) sirvio la comida a Juan_i
'Pedro (dat) served the food to Juan'

b. Pedro se_i la_j sirvio [e]_j a Juan_i
dat acc

c. *Pedro lo_i sirvio la comida a Juan_i
acc

(62)a. Pedro (lo_i) sirvio a Juan_i
'Pedro (acc) served Juan'

b. *Pedro le_i sirvio a Juan_i¹⁹
dat

The generalization behind the data in (61)-(62) is quite clear: we have here a verb that subcategorizes obligatorily for a complement that is assigned the θ -role of a goal. This complement appears both in (61) and in (62). Further, this verb optionally subcategorizes for an additional complement -- a theme -- which appears in (61), but not in (62). When this additional complement appears, it is between the verb itself and the goal complement, and is assigned accusative Case by the rule suggested in chapter 1 section 2 above. The accusative Case assignment rule is repeated here as (63):

(63) Accusative Case Assignment

$$[_V V, \text{accusative}] \longrightarrow V \text{ NP} \\ [+accusative]$$

Rule (63), as formulated, is "blind" to the thematic role of the adjacent NP. Thus we expect (63) to apply to the theme complement when it is present and to the goal complement when the theme one is not

present.

When both the goal complement and the theme complement are present, the goal complement is assigned dative. Intuitively speaking, it is clear that in some sense, in these cases the verb acquires the property of assigning dative to its complement. Let us call this "acquisition" dative formation, and formulate it as in (64):

(64) Dative Formation

$$[_v V, \text{accusative}] \longrightarrow [+dative] / \text{ ______ } X \text{ NP } Y$$

where X contains a complement of V

Note, however, that the actual assignment of Case to the NP in question cannot be done directly by the verb, since the verb is not adjacent to the goal complement in (61). Thus we will assume that the actual dative marking is achieved by a local rule of dative marker insertion, more or less along the lines suggested in Bordelois (1974):

(65) Dative Insertion ²⁰

$$\begin{array}{l} \text{NP} \quad \longrightarrow [+dative] / [_{vp} \dots \text{ ______ } \dots] \\ [-\text{Case}] \end{array}$$

A checking mechanism will then ensure that a verb with a dative-assigning feature, as in (64), will have a corresponding dative-marked complement. (Note that the rule in (64) specifies that the right hand environment of dative formation is X, where X is a complement of V. Note that in (61), X is invariably an accusative NP. As we will see below, however, there is reason to believe that the rule should be generalized as in (64), if we seek to capture both the dative constructions in (61)-(62)

and causative constructions. In section 4.3 below we return to the specific method of assigning dative Case in (65) as well as to some other properties of dative assignment and dative clitics. It will be suggested that French and Spanish differ with respect to (65).

Thus in (61), the verb servir acquires the property of taking a dative complement by rule (64). The X specified in rule (64) in this case is the NP la comida 'the food'. This property of the verb is attested by the availability of a dative clitic, as in (61)a,b. On the other hand, the dative complement itself, Juan, is assigned dative by the dative insertion rule in (65). This assignment is then checked against the dative Case assignment features of the verb servir.

Returning now to causative constructions, let us assume that causative interpretation is achieved by a rule of reanalysis which applies to structures such as (60)a-b above. Following this reanalysis, the subordinate verb becomes, in some sense, 'transparent'. In particular, the verb hacer 'to cause' is perceived as taking as its complements both the arguments which are in its government-domain and the strictly subcategorized arguments which are in the domain of government of the subordinate verb. (For other proposals regarding reanalysis, similar in spirit to ours, see Rizzi, 1978; Rouveret and Vergnaud, 1980; Zubizarreta, 1979a,b.)

Let us further assume that the reanalysis process can only take place if the lower, subordinate verb is adjacent to hacer. It follows that, assuming a process of reanalysis, some projection of V_2

must be fronted, and that it must be fronted precisely to a position in which it will be adjacent to hacer. Thus, it has to be adjoined to \bar{V}_1 . We can easily show that this must be the case. An adjunction to $\bar{\bar{V}}_1$ would not result in adjacency, since V_2^j would then follow the subordinate clause. Adjunction to V_1 , on the other hand, would imply that V_2^j (including the subcategorized complements) becomes part of the matrix verb, since both V_1 and V_2^j would then be dominated by the same terminal node. It follows that the only possibility is an adjunction to \bar{V}_1 .

In effect, the process of reanalysis implies that, rather than stipulating that fronting of some projection of V_2 has to take place, or stipulating that it has to be adjoined to \bar{V}_1 , we can assume that the fronting of some projection of V_2 is subsumed under "Move α " and that the adjunction is optional at any level. Note, however, that a failure to move some projection of V_2 will fail to create adjacency and thus the causative interpretation will be blocked. On the other hand, a failure to adjoin the moved projection to \bar{V}_1 will result in ungrammaticality as well, since only such adjunction will create the desired adjacency. As we will see below, the reanalysis process combined with the Case assignment properties of causative constructions also predict that only \bar{V}_2 can be fronted in some cases, rather than any other projection of V_2 .

Let us now turn to (60)a and (60)b above. Recall that we required that a complement be governed by the head which it is a complement of.

In (60)b this requirement is met: the argument which is in the domain of government of hacer is the subordinate subject José. The strictly subcategorized complements which are in the domain of government of the subordinate, fronted verb, are una carta 'letter' and a los chicos '(to) the children'. Since hacer is now perceived as taking these arguments as complements as well, it follows that it has to govern these complements as indeed it does in (60)b. This is due to the fact that in (60)b, \bar{V} was fronted rather than $\bar{\bar{V}}$. Since \bar{V} is not a maximal projection, hacer governs its complements (and see clause (ii) of the definition of government in chapter 2, (53) above). Thus, given the reanalysis process, the derivation given in (60)b above is well-formed.

Now let us consider (60)a. Following the reanalysis, hacer takes as complement the subordinate subject, José, which it governs. However, it also takes as its complements the complements of the subordinate, fronted verb. But in this case, since $\bar{\bar{V}}$, a maximal projection, was fronted, hacer cannot govern una carta and a los chicos. Since a head has to govern its complements, it follows that, after the reanalysis, (60)a is ungrammatical. Thus the reanalysis effectively forces fronting of \bar{V} , rather than any other projection of V, in causative constructions in RP Spanish. The fronting of V leaving behind its complements will result in ungrammaticality since neither hacer nor V_2 will govern the complements. On the other hand, the fronting of $\bar{\bar{V}}$ will block the government of the fronted complements by hacer,

thus violating the requirement that heads govern their complements.

Note that we are now equipped with an explanation for the impossibility of fronting complements that are not strictly subcategorized. Under the natural assumption that these complements are dominated by \bar{V} , fronting of them will result in the fronting of a maximal projection. Such fronting would then be ruled out as a violation of the requirement that hacer govern the complement of the subordinate verb. The impossibility of fronting non-strictly subcategorized complements has led many scholars to argue that the rule of verb fronting first suggested in Kayne (1969), moves the \bar{V} projection of the subordinate clause (this was first suggested in Quicoli, 1976). In the system which we are proposing, any projection of V can be fronted. However, independent considerations will render all occurrences of \bar{V} and V fronting ungrammatical, if the verb in question strictly subcategorizes for any complements. Thus, in the system proposed here, there is no need to stipulate that only \bar{V} is fronted. Note that if the subordinate verb does not strictly subcategorize for any complements, we would expect fronting of V, \bar{V} or $\bar{\bar{V}}$ to be possible. Since there are no complements which have to be governed by hacer and by the subordinate verb, the question of which projection is fronted should be irrelevant. Thus (66)a-c should all be grammatical derivations of (56)b:

(66) a.

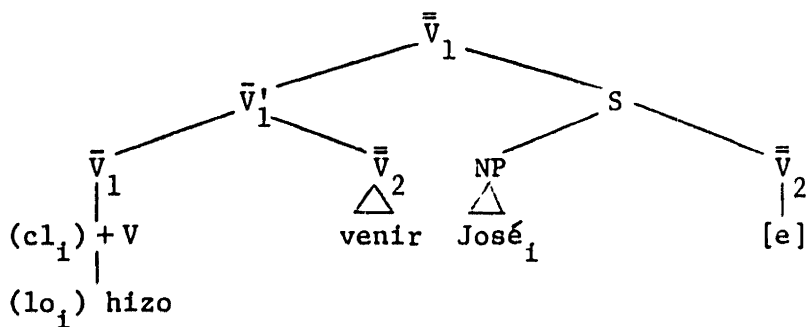

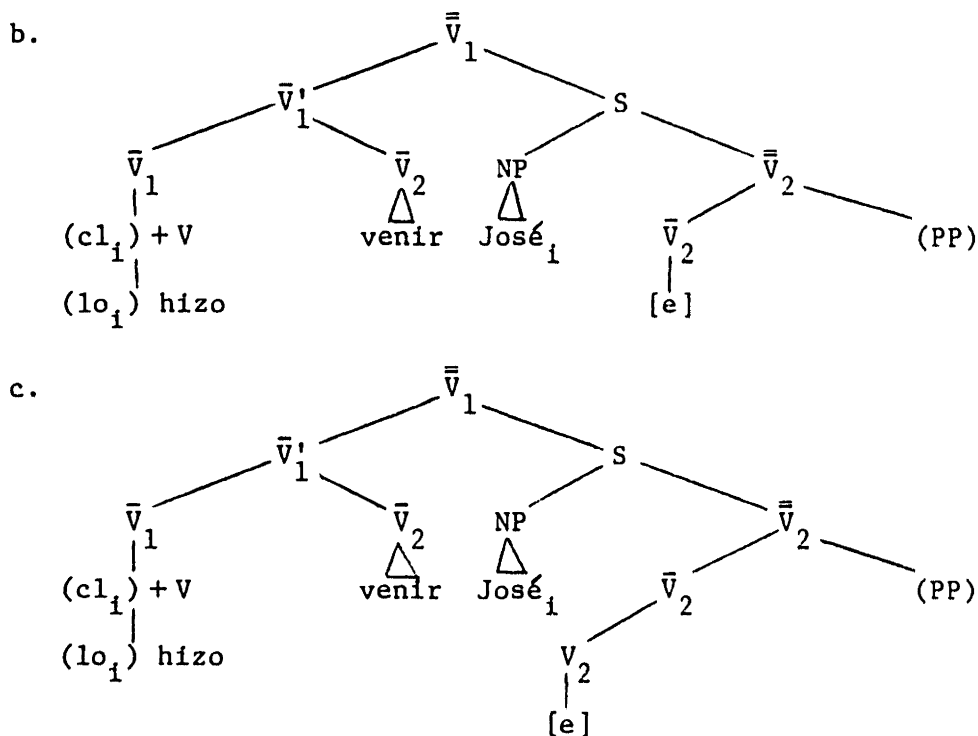

However, (66)a', in which a non-strictly subcategorized PP has been fronted, has a "scrambling" reading, equivalent to cases in which a direct object has been postposed:

(66)a'. María lo_1 hizo salir de la habitación a Pedro $_1$
 (compare with (58)a above)

We would like to suggest that, although (66)a is a possible structure for (56)b, the fronting of a non-subcategorized PP as in (66)a' is in fact the result of a scrambling rule which either postposes Pedro $_1$ or fronts the PP at a late stage of the derivation. We will return to the explanation of this proposal below, when we discuss Case assignment to the subordinate subjects.

Let us now consider the assignment of Case in causative constructions. Recall that when the subordinate verb is fronted along with a strictly subcategorized complement the subordinate subject is

assigned dative Case. However, when no complement is fronted (in other words, when the fronted verb does not take any strictly subcategorized complements) the subordinate subject is assigned accusative Case. Since we are assuming that both the subordinate subject and the complements of the subordinate verb are reanalyzed as the complements of hacer, we now have a situation similar to that of the verb servir 'to serve' above. We are considering a verb, hacer, which can take either one complement or two complements. When the two are present, the second one receives dative Case marking by rule (65). When only one is present, rule (63) should be applicable.

The situation in causative constructions, however, is slightly more complex. Unlike the servir cases, causative constructions contain two Case assigners: hacer itself and the subordinate, fronted verb. Let us then suppose that the Case on the subordinate arguments is assigned by the subordinate verb. In (57)a above accusative Case is thus assigned to la flauta by the verb tocar; in (57)b, accusative is assigned to una carta and dative is assigned to a los chicos by escribir, etc. Whatever Case is assigned to the subordinate complements, it is clear that if such subordinate complements exist, the subordinate subject can no longer be assigned accusative by hacer following rule (63). Although hacer has accusative Case-assignment features, the environment for accusative Case assignment as stated in (63) requires adjacency. When the subordinate verb takes complements, this adjacency condition is not met. (We will assume, however, that the subordinate verb itself, being transparent, does not count as an inter-

vening element for the application of (63).)

The assignment of dative Case to the subordinate subject in (57)a-c and (58)b will now follow directly from the formulation of the dative rules in (64) and (65). Hacer is an accusative-assigning verb and the complements of the subordinate verb are also complements of hacer, thus satisfying X in (64). Thus (64) is applicable and dative Case is formed. The application of (65) is free. However, the output is well-formed only if the dative NP is checked against a verb which requires a dative complement. In the case of (57)a-c and (58)b, the verb hacer, following the application of (64) has a dative feature and hence the application of (65) results in a well-formed derivation. Note that for the correct application of (64) it is irrelevant whether the accusative Case features of hacer are realized or not: it only matters that at the point at which (64) applies, hacer has these features and that there is an X such that X is a complement of hacer. As we saw above, in causative constructions, the accusative Case features of hacer will never be realized on the complements of the subordinate verb. These complements are still assigned Case by the subordinate verb itself. However, since they are nevertheless complements of hacer as well, accusative Case assignment to the subordinate subject is blocked.

If, on the other hand, the subordinate verb does not take any complements, as in (56)b and (58)a (and see corresponding structures in (66)), the application of (63) is not blocked. Assuming that V_2 is transparent, hacer is adjacent to the subordinate subject, and hence accusative Case assignment can apply. Consequently, we expect the subordinate subject in these cases to be accusative -- and both in (56)b and in (58)a it is indeed accusative.

Returning now to (66)a', note that Pedro_i is accusative as is attested by the corresponding accusative clitic. Rule (63), however, requires adjacency for accusative Case assignment to apply. If in (66)a' \bar{V} is fronted along with the non-strictly subcategorized PP, this adjacency condition is not met and accusative Case cannot be assigned. On the other hand, since PP is not a complement of hacer (it is not strictly subcategorized by the subordinate verb and it is not governed by hacer) it cannot be X in rule (64). Thus dative Case is not formed and if (65) applies to the subordinate subject, it will result in ungrammaticality since the dative subject, which is reanalyzed as a complement of hacer will not correspond to a dative Case assigning feature of hacer. Therefore, if the PP is fronted along in \bar{V}_2 , the subordinate subject cannot receive Case and the derivation is ruled out. However, when \bar{V}_2 does not contain a non-strictly subcategorized PP, its fronting will not lead to ungrammaticality, since hacer would still be adjacent to the subordinate subject and thus could assign accusative Case to it.²¹

Since in (66)a' accusative Case is assigned to the subordinate subject, we conclude that at the point at which (63) applied the adjacency condition was met and that the intervening PP appears following salir as a result of a late scrambling rule.

Corresponding to dative or accusative subordinate subjects, we have dative or accusative clitics attached to hacer. When the subordinate verb takes complements, we expect a dative clitic, which is indeed the case in (57)a-c and (58)b. When the subordinate verb does not subcategorize for any complements, we expect an accusative clitic, which shows up in (56)b and (58)a.

Let us now turn to the location of the clitics with respect to hacer and the subordinate verb (₂). Rivas indicate that the following

paradigm holds:

A. The clitic corresponding to the subordinate subject is always attached to V_1 (hacer):

(67)a. *María hizo tocarle_i la flauta (a José_i)
play-him (dat)

b. María le_i hizo tocar la flauta (a José_i)

(68)a. *María hizo venirlo_i (a José_i)
him (acc)

b. María lo_i hizo venir (a José_i)

B. The clitic corresponding to the complement of V_2 can be attached either to V_2 or to V_1 :²²

(69)a. María hizo escribirla
'Maria made X write it'

b. María la hizo escribir

(70)a. María hizo escribirle
'Maria made X write to him'

b. María le hizo escribir
'Maria made X write to him'

(71)a. María hizo escribirsela
'Maria made X write it to him'

b. María se la hizo escribir

Recall now that our analysis of clitics requires that the clitic govern the NP position which is coindexed with it. In view of this requirement, and given the definition of government in (43) above, let us now look at the structure of the sentences in (67)-(68) (irrelevant details omitted):

(72) (= (67)a, (68)a)

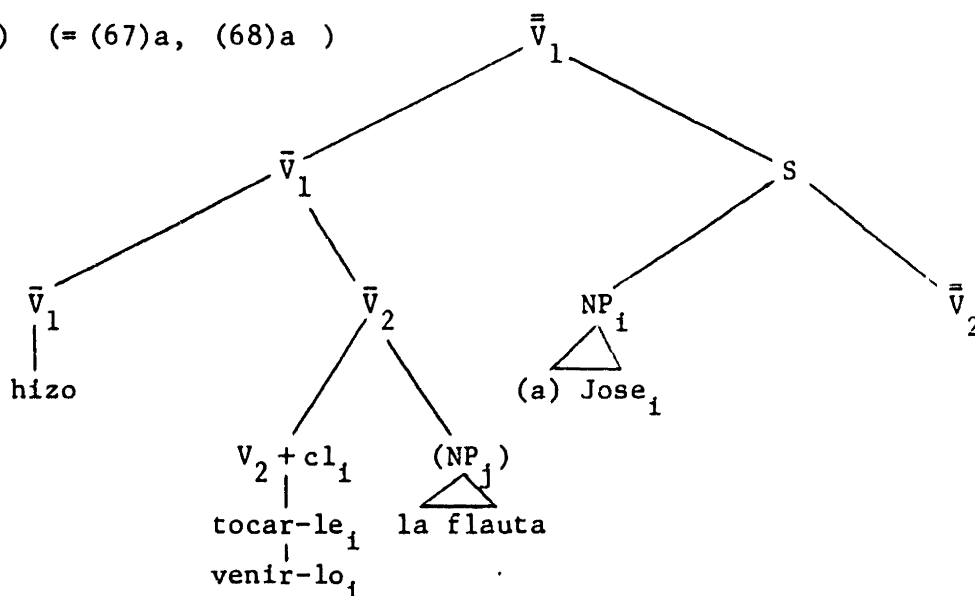

In (72), the clitic attached to V_2 does not govern the NP_i position, since, according to the definition of c-command in chapter 2, (42) above, the V_2 position to which the clitic is attached does not c-command NP_i . This follows from the fact that the \bar{V}_2 projection does not have the same head as the projection \bar{V}_1 which dominates NP_i . Since the clitic and the verb which it is attached to do not govern NP_i , NP_i cannot satisfy the subcategorization requirements of V_2 . In (68)a the verb does not strictly subcategorize for a complement and it does not have accusative Case assignment features; thus there is no possible source for the clitic and the sentence is ungrammatical. In (67)a, on the other hand, the argument which does meet the government requirement, NP_j , contains an index which is different from that of the clitic attached to V_2 ; thus the sentence is ruled out as a violation of the Complement Matching Requirement. (See chapter 1, subsection 3.2 for discussion.) (Note that this apparatus does not rule out a situation

in which both the subordinate subject in (72), José, and the subordinate object, la flauta, contain the index i . This situation, however, will be ruled out by the binding conditions, since the NP_1 position in (72) c-commands the NP_j position; the identity of indices in this case will result in la flauta being bound in its minimal governing category.)

Let us now look at the grammatical (67)b and (68)b. In these cases the subject clitic is attached to hacer. Given the definition of government assumed in chapter 2 (53) above, the clitic attached to hacer, in fact, governs both NP_1 and NP_j in a structure similar to that of (72). However, in order to be understood as coreferential with the subject, it has to be coindexed with it. The assignment of an identical index to la flauta in this case will result in a violation of the binding conditions, since NP_1 c-commands NP_j . (And see above for similar discussion with respect to (67)a.)

Now let us turn to sentences (69)-(71). In these cases, the clitic which is coindexed with the complement of V_2 can be attached either to V_2 or to V_1 . This is illustrated for direct objects in (73) (irrelevant details omitted):

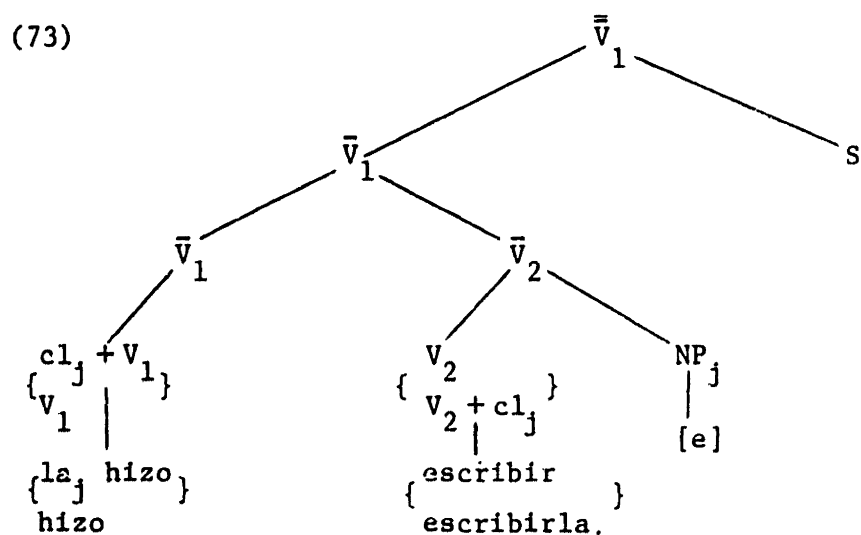

Since both V_1 and V_2 govern the NP_j position, it follows that the Complement Matching Requirement can be met by both positions, which is indeed true: the clitic can adjoin to either verb. For indirect objects, the same government relationship holds in a similar fashion. The relevant diagram for (71), in which two clitics can be attached to either verb, is (74):

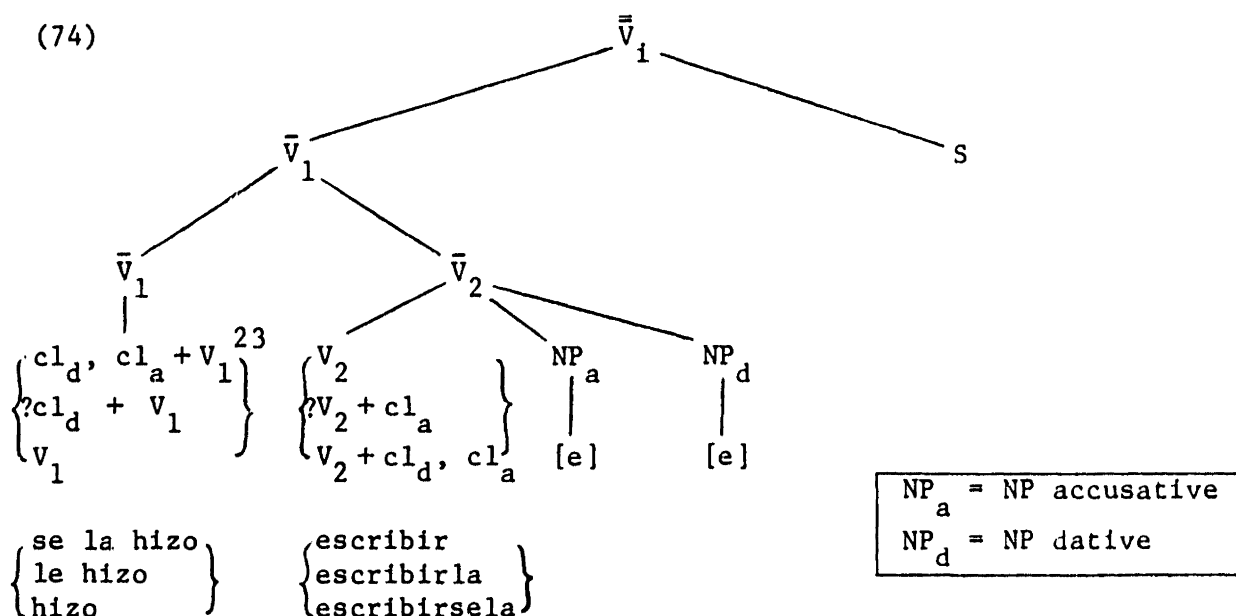

With respect to the cliticization of subordinate complements to hacer, one could reasonably raise the following questions: since we argued that the subordinate verb assigns Case to the subordinate arguments, and since we assume that clitics are spell-outs of Case features attached to that element which has these Case features, how can these clitics ever be attached to hacer, since the relevant Case is assigned by the subordinate verb? We will return to this question in section 4.1.1 below.

Returning to our point of departure, it has been shown that some interesting facts concerning the distribution of clitics can be explained if we assume the definition of government presented in chapter 2, (53) above, along with the Complement Matching Requirement and the assumption that government characterizes the domain of complementation. Insofar as our analysis accounts in a natural way for the distribution of clitics, it supplies strong evidence for the analysis of causative constructions outlined above. In particular, it provides evidence for the optional fronting of any projection of V and for the particular version of reanalysis which we have proposed.²⁴

4.1.1. A Note on Clitic Climbing

An interesting difference between the distribution of clitics in RP Spanish and French is connected to the phenomenon known as clitic climbing. Whereas in RP Spanish the objects of the subordinate clause can be cliticized to the subordinate verb, in French all clitics must be attached to faire. The attachment to V_2 of either the subordinate subject clitic or of the object of V_2 results in ungrammaticality:

- (75)a. *Jean a fait lui manger les bananes
 'Jean made her eat the bananas'
 b. *Jean a fait les manger à Marie
 'Jean made Marie eat them'

It is interesting to note, however, that (75)a is considerably worse than (75)b. Note that only the latter, but not the former, is possible in RP Spanish. We wish to argue that this follows from the fact that,

whereas (75)a is a violation of the requirement that a head governs its complement -- which has a universal status -- (75)b is a violation of the language-specific rule of reanalysis as it applies in French. Thus we expect (75)a to be worse.

The difference between cliticization in French and in RP Spanish can be explained if we assume for French a slightly different rule of reanalysis. Recall that we argued that, although in RP Spanish hacer "adopts" the subordinate arguments as its own arguments, Case is still assigned by the subordinate verb. Thus we expect cliticization to the lower verb to be possible. Although the combination hacer + V_2 functions as one verbal unit in many respects, V_2 still has Case features which can be spelled out as a clitic. In French, however, we would like to argue that faire in fact absorbs the Case features of the adjoined infinitive. The rule of reanalysis in French would thus be as in (76):

(76) Faire Reanalysis (obligatory)

$$[_V \text{ faire, accusative}] [_V V, [\alpha \text{ case}]] \longrightarrow [_V \text{ faire}, [\alpha \text{ case}]] V$$

Since now all Case assignment features are part of faire, it follows that only faire can take clitics: the spelling out of Case features can no longer apply to the lower verb.²⁵

A few questions may be raised with respect to the status of (76) and in particular with respect to its relation to the rule of Clitic Spell-Out suggested in chapter 1 (41) and the rule of Dative Formation (see (64) and the related discussion.) Clearly, for the rule of Dative

Formation in (64) to apply, faire still has to have its accusative Case features. However, it no longer has them following the application of (76), if [α Case] in (76) stands for dative Case. Furthermore, recall that the rule of Clitic Spell-Out can apply at any level (see above, section 3.4 for discussion). It seems, however, that the application of Clitic Spell-Out blocks the application of (76). Clearly (76) cannot apply in the base. (Recall that it is sensitive to adjacency relations created by the application of "Move α ".) Thus, (76) can apply either in the syntax, at S-structure or in PF. It appears, then, that when (76) is applicable, Clitic Spell-Out cannot apply in the base.

Nevertheless, we would like to argue that none of the rules we suggest are ordered with respect to one another. To the extent that any ordering is imposed on the application of the rules, it is imposed by constraints which exist independently in the grammar. Thus, for instance, if Faire Reanalysis in (76) applies prior to Dative Formation in (64), and if [α Case] in (76) is dative, Dative Formation can no longer apply. It follows that for the causative constructions, the subordinate subject can no longer be assigned dative Case by faire. Since there is no other way to assign Case to the subordinate subject, it follows that if Faire Reanalysis applies prior to Dative Formation the derivation is ungrammatical. The subordinate subject will not be assigned Case, and hence will violate the Case filter. If, on the other hand, [α Case] in (76) is accusative, Dative Formation can apply either before Faire Reanalysis or after it.

Let us now turn to the status of (76) with respect to the rule of Clitic Spell-Out. We would like to suggest that the rule in (76) is in fact a special instantiation of a more general rule which treats the phenomenon known as "clitic climbing", as it appears in cases of restructuring, causatives and auxiliary verbs. The transference of the Case features from a subordinate adjacent verb to a higher one will result in a clitic attached to the higher verb rather than to the lower verb. However, rather than assume that the rule of Clitic Spell-Out must always apply after the application of (76), we would like to argue that the specification [α Case] in (76) applies to spelled-out clitics as well. Thus, (76) should be generalized to the rule in (77):

(77) Case Climbing

$$[{}_{V} V, ([\alpha \text{ Case}])] [{}_{V} V, [\dots \beta \text{ Case} \dots]] \longrightarrow [{}_{V} V, [\dots \beta \text{ Case} \dots]] V_{[+F]}$$

The [+F] specifications on the higher verb will be lexical specifications, which will enumerate the class of verbs in which Case climbing is possible. These will include the auxiliary verbs in the Romance languages and perhaps the verbs which allow for restructuring in Spanish and Italian. (For discussion of verbs which allow for restructuring see Rizzi, 1978; Rivas, 1977; Burzio, 1981; and references cited therein.) Furthermore, [+F] verbs will include the verbs faire and laisser in French, hacer and permitir in Spanish (for a discussion of permitir verbs see section 4.1.2 below) and others.

We can now capture more precisely the nature of the variation

between the causative constructions of RP Spanish and of French. Whereas in RP Spanish the application of (77) in causative constructions is optional, in French it is obligatory. Thus, in French the subordinate clitics will always be attached to faire. This is true regardless of the stage at which Clitic Spell-Out has applied. Since the rule of Case Climbing as formulated in (77) will pick any matrix of features containing a Case specification, it will pick clitics as well, since clitics are [α number, γ gender, δ person, β Case]. In RP Spanish, on the other hand, (77) is optional in causative constructions; hence the clitics can remain attached to the lower verb. In both cases, the clitic will be in a position which governs the coindexed NP position. This will follow from the fact that, regardless of the application of (77), both faire and hacer take as their complements, after reanalysis, the arguments which are in the domain of the subordinate verb.

Our last point concerns (77) as it applies to auxiliary verbs. Assuming that auxiliary verbs are generated under the INFL node, as in (78), it follows that clitics which are attached to auxiliary verbs no longer govern elements inside the \bar{V} projection.

(78)

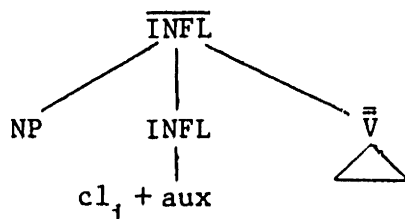

Since government is checked at S-structure, it is clear that at this level the clitic cannot be attached to the auxiliary verb. Thus, for

auxiliary verbs, (77) is effectively forced to apply in the phonological component. Its application at an earlier stage will bring about the impossibility of government between the clitic and the coindexed NP position, which will then result in ungrammaticality.

4.1.2. Permitir - Type Verbs in RP Spanish

Another "two-storey" construction in RP Spanish shows a distribution of clitics that can be easily explained under our assumptions. This is the permitir-type construction -- a class of cases in which V_1 takes a dative object which controls the subject position of V_2 . Consider the sentences in (79) (based on Rivas, 1977):

- (79)a. María le permiti^o tocar la flauta a José
'Maria permitted Jose to play the flute'
b. María le permiti^o a José tocar la flauta (marked order)
c. *María permiti^o tocar_{le} la flauta a José

We would like to propose that the underlying representation of (79) is as in (80):

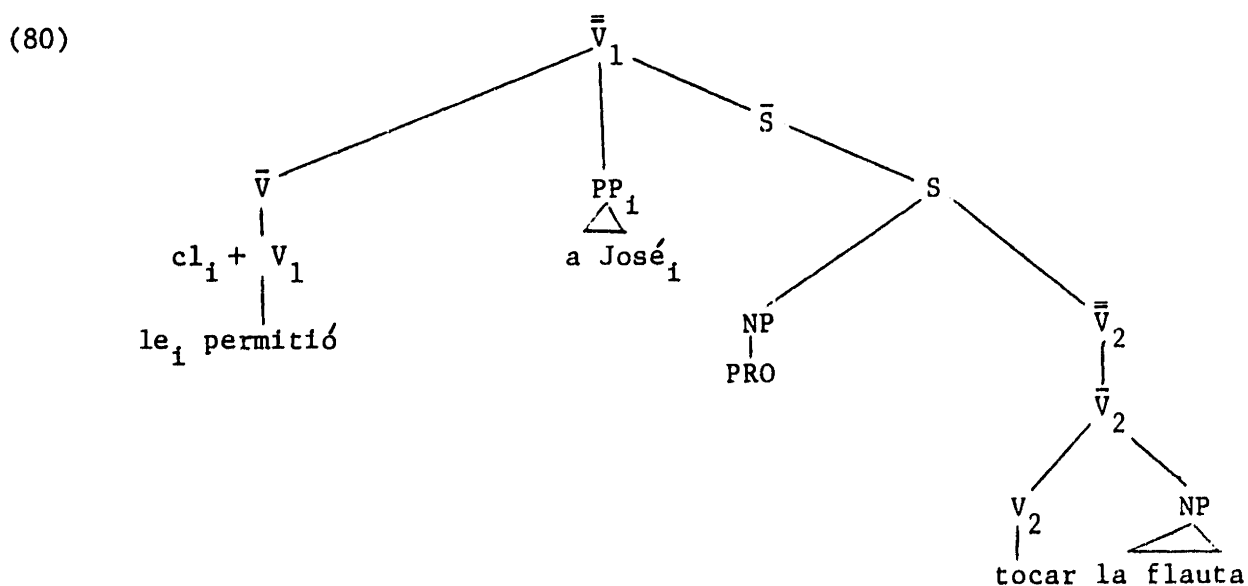

We will assume that permitir is a [+F] verb in the sense discussed above, and that following the fronting it takes as its complements the arguments of V_2 . It follows that only \bar{V} can be fronted, since otherwise government into \bar{V}_2 is not possible. The fronting of \bar{V} will result in the structure in (81) (note, however, that in this case the fronting is altogether optional):

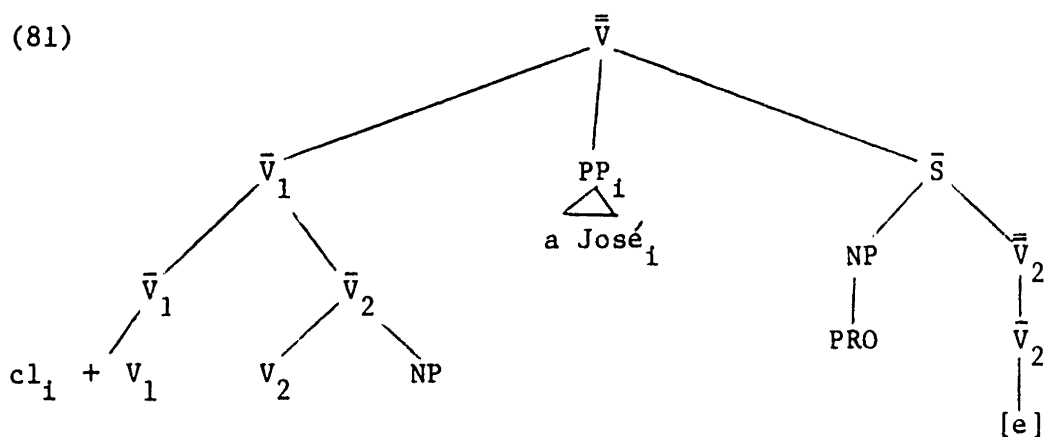

The derived structure in (81) already predicts the ungrammaticality of (79)c because the clitic is adjoined to V_2 , and thus fails to c-command elements outside \bar{V}_2 . Hence the clitic can neither govern nor be coindexed with PP_i , a José. Our analysis makes some more predictions with respect to the availability of clitics in the derived structure and the underlying structure. First, it predicts that if the rule of \bar{V} preposing does not apply and the structure remains as in (80), (corresponding to sentence (79)b), the object clitic cannot be attached to V_1 : it can only be attached to V_2 . This follows from the fact that government into \bar{V}_2 would be impossible from a position attached to V_1 .²⁶ However, if \bar{V}_2 has been fronted, we predict that the object clitic can

be attached both to V_2 and to V_1 due to the optional application of (77) and due to the government of object position by V_1 in the derived structure. These predictions are in fact correct:

- (82)a. se_i la permití escribir a Juan_i
 'I permitted Juan to write it'
 b. le permití besarla a Juan
 'I permitted Juan to kiss her'
- (83)a. le permití a Juan escribirla
 b. * se_i la permití a Juan escribir²⁷

Once again, these facts can be explained in a natural way, assuming clitic government, the reanalysis process sketched above and rule (77).

To conclude this section, it has been shown that some interesting facts concerning the distribution of clitics can be explained if we assume the definition of government in chapter 2 (53) and the requirement that clitics govern the element with which they are coindexed. We have also shown in this section that dative clitics are in exactly the same relationship with respect to the PP or NP position with which they are coindexed as are accusative clitics. These key points have been demonstrated both by the analysis of permit-type verbs in RP Spanish and by our analysis of causative constructions. In the latter case, the dative clitic corresponding to the subordinate subject could only be cliticized to a verb which governs the subordinate subject, thus again indicating that dative clitics behave in a fashion similar to accusative clitics. We return to these similarities in section 4.2.

4.2. On Extraction from Clitic-Doubling Configurations in RP Spanish: a Unified Account of a

Jaeggli (1980) observes that extraction from clitic-doubling configurations in RP Spanish is restricted to doubling in dative constructions. Thus we have the following contrast:

- (84)a. lo vimos a Juan
 b. *¿a quién lo vimos?
 'who did we see?'
 c. ¿a quién vimos?
 'who did we see?'
- (85)a. le han regalado ese libro a Juan
 'they gave this book to Juan'
 b. ¿a quién le han regalado ese libro?
 'to whom did they send this book?'

Jaeggli shows very convincingly that the contrast extends to all occurrences of variables in the object position of doubled constructions.

Thus we find the same contrast in relative clauses:

- (86)a. *María, a quien la he visto ayer, estaba muy preocupada
 'María, who I saw yesterday, was very worried'
 b. María, a quien he visto ayer, estaba muy preocupada
- (87) María, a quien le han regalado ese libro, estaba muy preocupada
 'María, to whom they gave that book, was very worried'

In configurations which have WH elements in situ we find the same situation:

- (88)a. *¿lo viste a quién?
 b. ¿viste a quién?
- (89) ¿le han regalado ese libro a quién?

and the same holds for quantifiers (90)-(91) and focus (92)-(93):

- (90)a. *las vi a todas las chicas
 b. vi a todas las chicas
 'I saw all the girls'
- (91) les regalaron libros a todos los chicos
 'they gave books to all the boys'
- (92)a. *yo le vi a JUAN
 b. yo vi a JUAN
 'I saw JUAN' (focus reading)
- (93) yo le regalare ese libro a JUAN
 'they gave this book to Juan'

Jaeggli accounts for the contrast by assuming that of the pair clitic / doubled element, the latter is never governed. This holds both for doubled direct objects and doubled indirect objects. It follows that an empty category left in the doubled position, i.e. the variable left after extraction, will never be governed. Since in Jaeggli's system [_{pp}e] are not subject to the Empty Category Principle, it follows that, although extraction from doubled indirect object configurations will leave an empty category, this will not suffice to rule out the output. In the direct object position, however, the variable is of the type [_{NP}e], and thus must be properly governed in accordance with the ECP. Since this position is never governed (let alone properly governed), all such occurrences are ruled out by the ECP.

(Parallel to the dialect of RP Spanish which does not allow for extraction from direct object doubled constructions, there is another dialect of RP Spanish which allows for such extraction (see Montalbetti, 1981; Hurtado, 1980). We will refer to the dialect which allows for extraction as RP Spanish B, and to the dialect which does not

allow for such extraction as RP Spanish A.)

As is obvious from the analysis of clitic-doubling configurations proposed in this study, we cannot adopt the solution proposed by Jaeggli. We have shown that the doubled position is governed by the coindexed clitic. In fact, we have shown that both in Rumanian and in Modern Hebrew the doubled position is properly governed as well, thus accounting for the availability of extraction from this position in these languages. Furthermore, in section 4.1 above we showed that in RP Spanish itself the distribution of clitics in "two-storey" constructions can be explained if we assume that both the direct object position and the indirect object position are governed by the clitic. (Note that arguing for clitic government results in arguing for clitic proper government as well. Since the conditions for proper government are government and coindexing, it follows that whenever a clitic governs a coindexed position it automatically properly governs it as well.)

Still further evidence against Jaeggli's proposal to account for the relevant distinctions in terms of a contrast between [_{pp}e] and [_{NP}e] comes from a variation which is found in RP Spanish A, which is referred to as the leísmo dialect. In this dialect, it is possible to substitute the accusative clitic in doubled constructions with a dative clitic, although the doubled element is still the direct object. Such substitution is attested in (94):²⁸

- (94) le_i vimos a Juan_i
 him (dat)
 'we saw Juan'

If such substitution occurs, extraction is grammatical:

- (95)a. ¿a quién_i le_i vimos? (compare (84)b)
 b. María_i, a quien_i le_i he visto ayer, estaba muy preocupada
 (compare (86)a)
 c. ¿le_i viste a quién_i? (compare (88)a)

Note that any proposal that extraction from doubled constructions depends crucially on the categorial nature of the extracted element clearly cannot account for the grammaticality of (95). Rather, it seems, we could more plausibly argue that a doubled element which has a corresponding dative clitic can be extracted, whereas a doubled element with a corresponding accusative clitic cannot be extracted.

We would like to suggest that the parameter which distinguishes Rumanian and RP Spanish B from RP Spanish A is closely related to this fact. Recall that we have been assuming the definition of proper government as in (96):

- (96) α properly governs β iff α governs β and:
 i. α is [+V]; or
 ii. α is coindexed with β

In our analysis of clitic doubling we have been mainly relying on clause (ii) of this definition. Now let us assume that the coindexing referred to in (ii) is well-formed only if α agrees in all its features with β . Such agreement of features will include agreement in gender, person and number (a fact that we have been tacitly assuming in our discussion of Rumanian) and also Case.

We will assume that the requirement of Case agreement is only valid if β has Case. It is important to note here that the Case agreement requirement is a condition on proper government and not on coindexing. Thus we do not assume that coindexed elements have to agree in Case. Rather, we assume that a coindexed governor has to agree in Case with the coindexed element in order to properly govern it.

Let us now assume (contrary to Jaeggli, 1980)²⁹ that in RP Spanish A the marker a has Case assignment properties identical to its prepositional counterpart: it assigns dative, not accusative Case. Thus in (97) Juan is dative:

(97) lo_i vimos a $Juan_i$
(dat)

Note that the coindexing between lo and Juan is still well-formed, although the clitic is accusative and Juan is dative. This is due to the fact that Case agreement is not a condition on coindexing, as explained above. However, under extraction the situation is different. In sentences such as (98), the empty category is marked as dative, as is its antecedent, a quién. The clitic, however, is a spell-out of the Case features of the verb, and thus is accusative:

(98) *¿a $quién_i$ lo_i vimos $[e]_i$?
(dat) (acc) (dat)

Following the requirement that coindexed governors agree in Case with empty elements which they properly govern, we expect the ungrammaticality of (98). Thus it follows that precisely in those cases where the

clitic is accusative and the doubled element is dative that extraction is not possible.

A different situation holds in (99).

(99) lo_i vimos $[e]_i$
(acc)

In this case a was never inserted. Consequently, there is no reason to suppose that the empty category is dative. In fact, there is no reason to assume that it is Case-marked at all. Thus it can be properly governed by the coindexed, governing clitic, and the ECP is not violated.

One could argue that verbs in RP Spanish, as in Rumanian, are proper governors themselves. It then follows that (99) should be grammatical, since the verb can govern the empty category. Recall, however, that we are assuming that the complex clitic+verb is one lexical unit, and that the clitic is a spell-out of a feature of the verb. We would like to argue that since this complex contains an index which is identical to the index of the governed element, clause (ii) of the definition of proper government has to be met: this coindexing has to create proper government. Since coindexing cannot here create a situation of proper government due to the Case conflict, the complex as a whole cannot serve as a proper governor. In effect, this means that although the verb is a proper governor, it cannot properly govern an element which contains conflicting information.

Let us now turn to the grammaticality of sentences such as (84)c in RP Spanish A. In this case, extraction of an a phrase has occurred,

leaving, presumably, a dative empty category. In this case, however, the sentence is grammatical. Still, there really is no reason why (84)c should be ungrammatical: the empty category is governed by the verb. Since the governing category does not contain an element which is coindexed with the trace, the Case requirement is irrelevant and the [+V] element can freely properly govern an empty category.

Again, we have explained the difference in extraction facts between Rumanian and RP Spanish A by utilizing the properties of grammatical formatives; the marker a in RP Spanish A and pe in Rumanian. Note that as in Rumanian (but not Hebrew) the formative a is available in the base. This is clear from the fact that it interacts with "Move α "; when a WH element is fronted, it is fronted with the marker a. Unlike Rumanian pe, however, a assigns to its complement a Case which is different from the Case features of the verb. In Rumanian, pe assigns accusative, just like the verb preceding it. This difference accounts for the availability of extraction in the latter and for its ungrammaticality in the former.

Clearly it is strange, functionally speaking, for a marker which is essentially a semantic marker (as a is in RP Spanish A) to assign a Case differing from that assigned by the verb that actually subcategorizes for the NP in question. However, when no clitic is attached to the verb, as in (100), the situation is even stranger:

(100) vimos a Juan

The marker a assigns dative Case to Juan, and consequently the accusative

(Recall that by complement we mean a strictly subcategorized complement. See chapter 1 section 3.2 for discussion.)

In chapter 1 we argued that Case assignment rules are local rules and that, as such, they require adjacency. In (64), however, the verb is not adjacent to the complement NP which is assigned dative Case (although in some other cases discussed below the verb is adjacent to its dative complement). Thus, we argued, an independent local rule will mark the non-adjacent complement as dative. The assignment of dative Case to the non-adjacent complement is then checked against the Case assignment features of the subcategorizing verb. Thus, in a sense, a verb with dative assignment features can be said to trigger the rule of Dative Insertion, repeated here:

(65) NP \longrightarrow [+dative] / [_{VP}...__...]
 [-Case]

Note, however, that there is another logical possibility. One might suggest that the verb subcategorizes for a PP rather than for an NP. The preposition would then assign dative Case to the NP in question. According to this last hypothesis, the verb would not have dative Case features; hence the dative clitic could not be regarded as a spell-out of dative Case features.

Interestingly, both in RP Spanish and in French there is some evidence that indicates that indirect objects are NP's rather than PP's, thus providing support for our analysis.

Vergnaud (1974) provides two tests which indicate that some indirect objects in French are NP's rather than PP's. Kayne (1975) observes that

some indirect objects fail some of these tests in a systematic fashion. Thus it is plausible to assume that, whereas the former are in fact NP's which are marked as dative, the latter are genuine PP's. This contrast is exemplified in (101)-(103):

(101) conjunction of objects of prepositions:

- a. *ils ont parlé à Marie et le directeur
'they talked to Mary and the director'
- b. ils se sont assis sur la table et les chaises
'they sat on the table and the chairs'
- c.* ils ont pensé à Marie et le directeur -
'they thought about Marie and the director'

(102) PP's vs. NP's as heads of relative clause:

- a. il a parlé à l'homme et à la femme qui se sont rencontrés hier
'he talked to the man and to the woman who met yesterday'
- o.k. b. *il a compté sur l'homme et sur la femme qui se sont rencontrés hier
'he counted on the man and on the woman who met yesterday'

(103) PP clitics vs. NP clitics

- a. je parle à Jean
- b. je lui parle
- c. je vais à Paris
- d. j'y vais
- e. je pense à Jean
- f. j'y pense
- g. *je lui pense

In (101) we see that, unlike the real preposition sur in (101)b, the marker à cannot take a conjoined object. However, when it appears following

the verb penser, it can take a conjoined object. In (102) we see that, whereas indirect objects can serve as heads of relative clauses, real PP's cannot. In (103), we observe that, while the indirect object corresponding to the verb parler can be a dative clitic, the indirect object corresponding to the verb penser cannot be a dative clitic (cf. (103)g). Rather, if cliticized, it has to be a PP clitic (cf. (103)f). (For a more detailed review of various distinctions among indirect objects which are real PP's, indirect objects which are NP's, and PP's, see Jaeggli, 1980.)

The object of à both in the penser cases and in the parler cases can be plausibly assumed to be marked as dative. Nevertheless, there are two differences between these two configurations: first, parler subcategorizes for an NP while penser subcategorizes for a PP. Second, while parler takes a dative clitic, penser takes a PP clitic. If we wish to reduce these two distinctions to one, it seems plausible to argue that, whereas with penser, dative is assigned by the preposition itself, with parler, the verb has dative Case features, which in turn triggers the application of (65) above. This account will reduce the contrast between the availability of dative clitics for parler and their unavailability for penser to the fact that, whereas parler requires a dative complement, penser subcategorizes for a PP.

A similar situation holds in RP Spanish. In RP Spanish there are no PP clitics. However, indirect objects behave differently from real PP's in two respects. First, the former have corresponding dative clitics whereas the latter do not:³¹

- (104)a. les_i mandaron cartas a los padres_i
'they send letters to the parents'

- b. Juan fué a Paris
'Juan went to Paris'
- c. *Juan le fué

Second, there is, as we discussed, a stylistic constraint in RP Spanish against the occurrence of two a phrases (see footnote 15 for discussion). This constraint holds for a sequence of two a phrases when they are both indirect objects or when they consist of a direct object preceded by a and followed by an indirect object. However, the constraint does not hold for two a phrases when they are both directional PP's, nor does it hold when the first a phrase is an indirect object and the second is a directional PP:

- (105)a. ?Juan presentó a Pedro a José
'Juan introduced Pedro to Juan'
- b. ?Juan le_i hizo escribirles_j a los chicos_j a José_i
'Juan made Jose write to the children'
- c. Juan llevó a maría al cine a las cinco
'Juan took María to the movie at 5 o'clock'
- d. Juan lo presentó a Pedro a las cinco
'Juan introduced him to Pedro at 5 o'clock'

The distinction between the grammaticality of (105)c-d and the marginality of (105)a-b indicates that the restriction against two adjacent a phrases does not hold for genuine PP's. It only holds for inserted Case markers, such as the direct object marker discussed in section 4.2 above and the indirect object marker. Thus, for RP Spanish as well as for French, we conclude that verbs which take indirect objects are verbs which have dative Case assignment features and which subcategorize for an NP. This NP is then assigned dative by (65), and this assignment is checked against the

- (107) les compraron una casa a María y el director
 'they bought a house for Maria and the director'
 (and cf. the ungrammaticality of (101)a)

The assumption that dative insertion is as in (106)a in RP Spanish but as in (106)b in French can account for the grammaticality of (107) vs. the ungrammaticality of (101)a. Let us consider the nature of the rule in (106)a. In this case, the preposition a is inserted and Chomsky-adjoined to the NP. We argued above that this preposition has dative Case-assignment features. These Case-assignment features are then assigned to each of the conjoined NP's in a fashion similar to the assignment of Case to conjoined NP's by a governing preposition in a genuine PP. Thus we expect the grammaticality of (107).

On the other hand, in French, following (106)b, à is simply a morphological manifestation of the Case marking of a particular NP. Since every NP has to be Case-marked, and since in (101)a there are two NP's with only one morphological manifestation of Case assignment, the sentence is ruled out. Of course, if à is attached to both parts of the conjunction, the sentence is grammatical. In this way, the different properties of (106)a and (106)b predict the difference between (107) and (101)a.

We would like to claim that the difference between (106)a and (106)b can also account for the contrast between the availability of clitic doubling of indirect objects in RP Spanish and its impossibility in French. Let us assume as a rather natural principle a one-to-one correspondence between Case assignment and Case-assignment properties. Now recall that the output of (106) (= (65)) is checked against the

availability of dative Case features in the head verb. Interestingly, due to the prepositional nature of a in RP Spanish (a constant property, even though, when adjoined to NP following the application of (106)a, it does not change its categorial status), for every indirect object construction in RP Spanish there are two sets of dative-assigning features. Although the output of (106)a still must be checked against the dative features of the selecting verb, these two sets of dative-assigning features render grammatical a situation in which a dative clitic appears, absorbing the dative Case features of the verb, alongside a dative complement, assigned Case by the inserted preposition a.

Now consider the situation in French. In French, again, the output of rule (106)b is checked against the Case features of the selecting verb. However, note that in (106)b the dative Case features are introduced without the presence of Case-assignment features. Thus, only the existence of such Case-assignment features can render the assignment of dative Case by (106)b grammatical. These Case-assignment features are the features on the head verb. If, however, these features have been absorbed by a clitic, the one-to-one relationship between features of Case assignment and Case-marked elements no longer holds and the derivation must be ruled out as ungrammatical. Thus, doubling in indirect objects in French is ungrammatical.

Note that reducing the contrast between the availability of clitic-doubling in RP Spanish and its unavailability in French to the properties of Dative Insertion is entirely compatible with our assumptions about the nature of parametric variation. We have found a local rule which applies

differently in two different languages, and this results in substantial variation in clitic configurations between these two languages.

4.3.1 Inalienable Possession Constructions

Cases of inalienable possession have several properties. First, doubling in these cases is obligatory. Second, in these cases, the direct object is perceived as being part of the indirect object. This situation is exemplified in (108):

- (108)a. le_i duele la cabeza a Juan_i
 him hurts the head to Juan
 'Juan has a headache'
- b. le_i rompieron la pata_j a la mesa_i
 'they broke the leg to the table'

In (108)a la cabeza 'the head' can only be interpreted as Juan's head. In (108)b, la pata 'the leg' can only be interpreted as the leg of the table. In both cases, the absence of the clitic will lead to ungrammaticality.

As observed by Jaeggli (1980), the ungrammaticality of inalienable constructions without a clitic derives from the fact that when the clitic is absent, the indirect object is interpreted as a goal. Since the goal interpretation is nonsensical in (108)a-b, the sentences are rendered ungrammatical.

Jaeggli further argues, that the ungrammaticality of the non-clitic variants of (108)a-b should be derived from the θ -criterion. "The presence

of the clitic", Jaeggli reasons, "is required to construct the adequate meaning of these sentences. Without the clitic, the a NP complement is interpreted as a goal. The verbs which allow this construction do not select a goal object. Therefore, if those NP's are assigned that thematic role, we can assume that the sentence is ruled deviant." In this section, we will adopt the essentials of Jaeggli's proposal, assuming that the obligatoriness of clitics in (108)a-b indeed derives from the θ -criterion. However, we will derive this result in a different way.

Jaeggli argues that in "inalienable constructions", the clitic can be said to bear a special θ -role, θ_p . This θ -role is then transmitted to the NP object by a special rule which is sensitive to coindexing (but not to government or c-command. Recall that in Jaeggli's system the clitic crucially does not govern or c-command the doubled element). We would like to argue, on the other hand, that no transmission rule is necessary. The assignment of the θ -role p ("inalienable possessor") to the doubled NP in (108)a-b is similar in nature to the assignment of θ -role to other arguments argued for in detail in chapter 1, section 3.2. Recall that we argued that the process of θ -role transmission involves the transference of a referential index from an argument to an empty slot in the thematic matrix of the head which selects this argument. Further recall that we argued that when a clitic is present it is linked to one of the thematic matrices of the head. Let us now assume that the θ -role p can only be assigned to an argument if the thematic grid to which it transfers its referential index already contains a clitic.

In essence, this proposal means that once the clitic is present

in the thematic matrix of a verb, it transforms the θ -role assigned by this matrix into a p role. Thus, the thematic matrix of p-role assignment for a verb such as rompir in (108)b is as in (109):

$$(109) \quad [{}_V V, \left[\begin{array}{c} \Delta \\ \text{theme} \end{array} \right] \left(\left[\begin{array}{c} \text{cl}_i \\ \Delta \\ \text{p-role} \end{array} \right] \right)]$$

The empty slots in (109) are in turn replaced by the referential indices of the subcategorized complements. Given the process of θ -role assignment which we propose, then, the relationship between the clitic and the assignment of the p role can be stated as a condition on θ -matrices. Although we still argue that the presence of a clitic is essential for the assignment of a p role, we no longer have to assume a separate assignment of θ -role to the clitic and a rule which transmits the θ -role to the doubled NP. Rather, it follows from independent considerations that the clitic has to be associated with thematic matrices. Since it is associated with them, the connection between the assignment of the p role and the availability of a clitic is quite natural.

(For some more discussion of inalienable possession constructions as well as some discussion of the phenomenon as it appears in French, see Jaeggli, 1980.)

Let us now summarize our discussion of RP Spanish. In section 4.1 we argued that the requirement that clitics govern their doubled elements (whether fully realized or [e]) can account in an interesting way for the distribution of clitics in "two-storey" constructions in RP Spanish. In particular, we proposed an analysis of causative constructions that involved a rule of v^j fronting. We showed that the limitation of fronting to \bar{V} in most cases follows from both the requirement that a head must govern its complements and from the process of reanalysis in causative constructions, which causes the causative verb hacer (or faire in French) to take all subordinate complements as its own. We further showed that adjunction of the fronted category is itself free, but is only well-formed at the \bar{V} level of the matrix verb. This fact as well follows from the government requirement and from the formulation of the reanalysis process. Once the right configuration has been established, it was shown that the distribution of clitics in causative constructions follows directly from the government properties of the structural configuration. Clitics consistently appear precisely in those positions which allow them to govern the doubled elements.

In section 4.1 we further showed that there are some distinctions between the process of reanalysis in French and the process of reanalysis in RP Spanish, these differences were reduced to the optional vs. the obligatory application of a rule of "Case climbing": while the rule is obligatory in French causatives, in RP Spanish it is optional. The rule of "Case climbing" was shown to be the same rule which accounts for the phenomenon known as clitic climbing, and in particular, for the fact that clitics in Romance are attached to the auxiliary node, and not to the verb,

although they spell out the Case features of the verb, and not of the auxiliary.

In section 4.2, we argued that some differences between extraction facts in RP Spanish and Rumanian can be explained if we bear in mind the fact that a in RP Spanish is a dative marker, whereas pe in Rumanian is an accusative marker. Given this distinction and a slight change in the formulation of proper government, requiring that a coindexed proper governor agree in Case with the element which it governs, we reduced the differences between Rumanian and RP Spanish to the idiosyncratic properties of dummy Case markers.

In section 4.3 we elaborated on the nature of dative clitics. We produced some evidence for the existence of dative Case assignment features in particular verbs, which can in turn be spelled out as a clitic. In so doing, we explained the nature of dative Case assignment and argued that the local rule which assigns dative Case in RP Spanish differs from the rule which assigns dative Case in French. While the former involved the insertion of a preposition, the latter was simply a morphological marking of the dative NP. This difference was then shown to account for the availability of clitic doubling in indirect objects in RP Spanish vs. its absence in French. In the last paragraphs of section 4.3, we showed that Jaeggli's conclusions with respect to the interpretation of inalienable possessive constructions and the obligatoriness of clitics in these constructions can be incorporated very naturally into a system which assumes the mechanism of θ -role assignment sketched in chapter 1. Within

such a system, the obligatoriness of the clitic is captured as an easily statable condition on the well-formedness of thematic matrices which assign the θ -role of an inalienable possessor.

In chapter 3, several local rules, in the sense defined in chapter 1, were introduced: rules governing the insertion of a Case marker (such as ^vsel insertion and pe insertion), rules of Case marking (e.g. Accusative Case Assignment and Dative Insertion) and a rule of Case Climbing. It was shown that many of these rules are subject to parametric variation, either in the way in which they apply (Dative Insertion), the Case which they assign (a vs. pe) or the level at which they apply (^vsel insertion vs. pe insertion). The range of grammatical phenomena and of parametric variation that was explained by these rules was quite extensive: we accounted for differences in extraction between Rumanian and Modern Hebrew; for facts of anaphoric binding in Rumanian and Hebrew; for properties of "two-storey" constructions in RP Spanish and their differences from French; the differences between extraction in Rumanian and RP Spanish and differences in the availability of indirect-object doubling in RP Spanish and French.

Insofar as these local rules and the parametric variation proposed with respect to them account for these phenomena, the constructions explained in this chapter supply strong evidence for the analysis proposed in this chapter and in the previous chapters. They further supply evidence for the framework assumed and for the theoretical assumptions behind this framework.

APPENDIX: A Note on French Causatives

It is worthwhile to note at this point how our analysis of causative constructions in RP Spanish fares with respect to certain differences between the causative constructions in French and RP Spanish. Kayne (1969, 1975) notes that in French direct objects are fronted with the verb in causative constructions, but indirect objects are not. Thus, compare the grammaticality of (110) with the ungrammaticality of (111):

(110) Marie a fait téléphoner Jean à ses parents
'Marie made Jean telephone his parents'

(111) *Marie a fait téléphoner à ses parents à Jean

It is likely, however, that the ungrammaticality of (111) derives from a constraint against the occurrence of two adjacent à phrases, which is independently argued for by Kayne. Thus, in cases in which the indirect object is not an à phrase, the fronting of a strictly subcategorized indirect object is grammatical, as is illustrated by (112)a-c:

(112)a. j'ai fait rêver de Marie à Jean
'I made Jean dream of Marie'

b. j'ai fait mettre les bananes sur la table à Pierre
'I made Pierre put the bananas on the table'

c. j'ai fait parler de Marie à Jean
'I made Jean talk about Marie'

Furthermore, as noted by Ruwet (1972), when the constraint on two adjacent à phrases is violated in cases such as (113), the preferred interpretation is the one in which the last à phrase is the subordinate subject, thus indicating that in these cases the indirect object is fronted along with the subordinate verb:

- (113) j'ai fait écrire la lettre à Marie à Jean
'I made Jean write the letter to Marie'

Further evidence for the availability of indirect object fronting in French is the fact that a dative clitic can correspond to the subordinate subject in sentences such as (114)a-b:

- (114)a. Marie lui a fait téléphoner à ses parents
'Marie made him telephone his parents'
b. je lui ai fait rêver de Marie
'I made him dream of Marie'

Thus we conclude that the fronting of strictly subcategorized indirect objects is in fact possible. On the other hand, the fronting of a PP which is not strictly subcategorized will not result in dative assignment to the subordinate subject. Rather, it will have a "postposed object" reading:

- (115) Jean a fait venir de Paris Marie
'Jean made Marie return from Paris'

Note, however, that in French, crucially, the fronting of an indirect object is often optional, even when it is strictly subcategorized. Thus (110) above is grammatical, and (116), corresponding to (112)c, is grammatical as well:

- (116) j'ai fait parler Jean de Marie

The grammaticality of (110) and (116) would seem to present a problem for our analysis: note that in (110) and in (116), if the indirect object is not fronted, it is no longer governed by the subordinate verb or by faire. Clearly reanalysis cannot apply in these cases, since faire does

not govern the non-fronted indirect object at any stage. However, it is plausible to argue that in these cases the trace of the subordinate verb can satisfy the government requirement of the subordinate verb. Thus, although reanalysis fails to apply in that faire does not take the subordinate arguments as its arguments, the subordinate arguments are still governed by the verb which selects them; thus the sentence does not violate the government requirement.

Interestingly, it seems that the reanalysis process as described in the text can be divided into two parts: (1) the "merging" of faire and the subordinate verb, and (2) the "adoption" of the subordinate arguments as the arguments of faire. Let us assume that in sentences such as (110) and (116) the first part has applied but the second one has not. Now note that once any argument of the subordinate verb is fronted, the "adoption" part -- part (2) -- of reanalysis has to apply. It follows that we do not expect to find a situation in which the direct object is fronted but the indirect object is left behind. In these cases, the "adoption" part of the reanalysis process has been invoked, thus the failure of all strictly subcategorized arguments to front results in ungrammaticality, since faire cannot govern the "adopted" argument. This is indeed the case. Once the direct object has been fronted, the indirect object has to be fronted as well. Evidence for this is the preferred reading of (113), as well as the ungrammaticality of (117) (and compare with (112)c above):

(117) *Jean a fait mettre les bananes à Marie sur la table

Yet another problem with respect to French causatives relates to the fact that in sentences such as (114)_a above, the clitic lui cannot be construed as the indirect object. It has to be construed as the subordinate subject. Kayne (1975) argues that this is due to the specified subject condition. Note, however, that the specified subject condition is only relevant if the indirect object is not fronted. If it is fronted, the specified subject condition can no longer be invoked. Note also that this restriction in French is similar in nature to the restriction in RP Spanish discussed in footnote 22 above.

Further evidence against the specified subject condition as an explanation for the unavailability of an indirect object reading for the clitic in (114)_a is given in Wehrli (forthcoming). Wehrli notes that the phenomenon attested in (114)_a extends to the paradigm in (118) in which the cliticization of a direct object is blocked when certain clitic forms are used. In this case, the specified subject condition cannot be invoked:

- (118)_a. Jean a fait embrasser Marie à Pierre
'Jean made Pierre kiss Marie'
- b. Jean l'a fait embrasser [e] à Pierre
- c. *Jean m'a fait embrasser [e] à Pierre
'Jean made Pierre kiss me'
- d. *Jean vous a fait embrasser à Pierre
'Jean made Pierre kiss you'
- e. Jean lui a fait embrasser Marie [e]
'Jean made him kiss Marie'
- f. Jean m'a fait embrasser Marie [e]
'Jean made me kiss Marie'
- g. Jean vous a fait embrasser Marie [e]
'Jean made you kiss Marie'

The contrast between the ungrammaticality of (118)c-d and the grammaticality of (118)f-g is similar in nature to the contrast between the ungrammaticality of (114)a with the clitic interpreted as the indirect object and the grammaticality of the reading in which it is the subordinate subject. However, the specified subject condition clearly cannot be invoked to explain the ungrammaticality of (118)c-d.

We thus conclude that the unavailability of an indirect object interpretation for the clitic in (114)a is not related to the specified subject condition. Rather, it is semantic in nature and is similar to the same (semantic) restriction in RP Spanish.

FOOTNOTES: CHAPTER 3

1. (9)c is grammatical if un bucătar 'a cook' is specific.
2. The sentences in (26)-(28) also demonstrate that the 'matching effect' (in the sense of Grimshaw (1977), see chapter 2 footnote 21 for discussion) holds in kumanian free relatives with respect to the pe marker. Thus only when the matrix takes a pe-type object can there be a free relative where extraction is from a pe-type object. It follows that in free relatives doubling is attested both in the matrix and in the subordinate clause.

Note that if we assume that in (26) fronting has taken place and if we assume that pe is fronted along with the WH element, we should end up with a sequence of two pe's: one resulting from fronting and one base-generated in the matrix. We will argue below that, in fact, since pe insertion is free to apply at any level (base, S-structure or PF), although the derivation which contains pe pe sequences may be ruled out, there is an alternative derivation, in which only one pe has been inserted -- which is grammatical.

3. The question of how to characterize the semantic environment which we have labelled [+P] is not a trivial one. A functional explanation of pe occurrences may shed some light on this matter: it seems that object markers are usually available in relatively free word-order languages, as a device to disambiguate sentences in which the direct object could plausibly be misinterpreted as the subject. Thus in (1) there is no ambiguity, even if the word order is free, since only

John can satisfy the agentive reading which eat requires. On the other hand, in (ii), the marking of Bill as the direct object disambiguates the sentence. In a language in which the position of NP's in a string is irrelevant to their grammatical role, the presence of an object marker preceding Bill is thus desirable:

- (i) John ate the apple
- (ii) John killed Bill

This issue will not be pursued further in this study.

4. Recall that the same holds for $\overset{V}{S}el$ (see chapter 2, section 2.3 for discussion). This, in fact, seems to be a general property of dummy Case assigners which may follow from their classification as grammatical formatives (and see chapter 1 for some discussion of grammatical formatives).

5. There are, in fact, some cases in which $\overset{V}{S}el$ appears and which do not seem to be covered by the environment for $\overset{V}{S}I$ in (25). However, upon closer inspection, all these cases are of an equative nature, as is demonstrated by (i)a-b:

- (1)a. ha-bayit haya $\overset{V}{S}el$ Xana
 the-house was of Xana
 'the house was of Xana's'
- b. ha-bayit nir'a $\overset{V}{S}el$ Xana
 the-house seemed of Xana
 'the house looked like it was Xana's'

(i)a-b are exactly synonymous to (ii)a-b:

- (ii)a. ha-bayit haya ha-bayit $\overset{v}{\text{sel}}$ Xana
 the-house was the-house of Xana
- b. ha-bayit nir'a ha-bayit $\overset{v}{\text{sel}}$ Xana
 the-house seemed the-house of Xana

The only occurrences of $\overset{v}{\text{sel}}$ in an environment that does not appear to fall within the environment specified in (25) are in this class: they all have an exactly synonymous corresponding sentence, in which the occurrence of $\overset{v}{\text{sel}}$ does satisfy the environment in (25).

We would like to argue that, in fact, (i)a-b are cases of ellipsis, and that (i)a-b actually have the structure in (25), but the head bayit 'house' was deleted under identity with the subject. Thus the structure of (i)a is as in (iii):

- (iii) ha-bayit haya [_{NP_j} \emptyset $\overset{v}{\text{sel}}$ NP_i]
 the-house was of John

In (iii) the environment for $\overset{v}{\text{sel}}$ insertion is met in the usual way, independently from the deletion of the head.

6. One could plausibly argue that when the $\overset{v}{\text{sel}}$ phrase is branching, the clitic attached to N_1 in (i) below cannot govern the coindexed \bar{N}_2 position. This is due to the fact that only the \bar{N}_2' position can be governed since government cannot "enter" maximal projections:

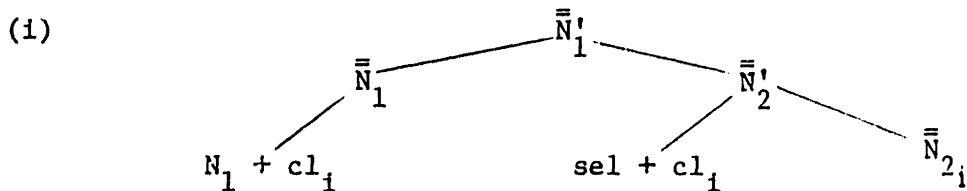

Note that if the clitic attached to N_1 does not govern \bar{N}_2 , then \bar{N}_2 cannot be perceived as satisfying the complementation requirements of N_1 and we do not expect the Complement Matching Requirement to be relevant. Since it is not relevant, one could enquire why the co-indexing in (i) between the clitic attached to N_1 and \bar{N}_{2_1} is still obligatory.

We would like to claim that in (i) the clitic on N_1 , in fact, governs \bar{N}'_2 and that \bar{N}'_2 is perceived as satisfying the complementation requirements. Thus \bar{N}'_2 has to be coindexed with the clitic. The fact that \bar{N}'_2 and \bar{N}_2 share the same index will then follow from the percolation of indices from the maximal projection to the head through all the intervening nodes. As for proper government, note that if the clitic on N_1 does not govern \bar{N}_2 , it cannot properly govern it either. Nevertheless, the position is properly governed by the clitic on \underline{V}_{sel} . It follows that the clitic on \underline{V}_{sel} has to have the same index as the clitic on N_1 , as \bar{N}_2 and as \bar{N}'_2 .

Note that in this case the obligatory presence of a clitic attached to \underline{V}_{sel} follows from the ECP, rather than from the assumption that Case features of grammatical formatives have to be realized (see fn. 4 above). The assumption that Case features have to be realized, however, cannot be dispensed with, since it holds for grammatical formatives which are inserted in the phonological component as well. In this case, the obligatoriness of Case realization cannot be derived from ECP.

7. The difference between (47)a (in which pe and doubling do not occur) and (47)b (where both pe and doubling occur) is that in (47)a the girl is perceived as being objectified in some sense. This

variation is possible with few Rumanian verbs, notably the verbs 'to show' a arata and 'to see' a vedea.

8. A genuine independent reflexive form (as opposed to a reflexive clitic) is not used in Rumanian. Rather, the antecedent-reflexive relationship is tested here with an emphatic pronominal form, which is sensitive to c-command and to the binding conditions in the usual way. Thus (1), in which no c-command holds between the antecedent 'Mary' and the emphatic pronoun, is ungrammatical:

- (1) *casa Mariei_i a ars din cauza ei_i ¹însiși_i
 house-the Mary's has burned from cause her's her/emphatic
 'Mary's house burned because of her/*herself'

9. Note that so far we have not ruled out the insertion of pe, a [+P] marker, preceding a [-P] element, if such insertion takes place in PF: in this case, the impossibility of interpretation is irrelevant, since pe insertion in PF does not feed into LF. (I am indebted to Donca Steriade for pointing this out.)

Let us, however, assume that when Case markers are inserted in the phonology, they are truly "rescuing devices". As such, they are inserted only preceding [-Case] elements. Thus they will be inserted in doubling configurations, but not in any other configurations. (Recall that occurrences of pe without doubling have to be instances of PI at S-structure.)

10. Clearly, our account for the insertion of Case markers is not complete. A notable problem is presented by the definite object marker 'et in Modern Hebrew. Since it supplies crucial semantic

information, call it [+E], and since it does not "trigger" doubling, we expect 'et + NP configurations always to branch; thus we do not expect the NP complement of 'et ever to serve as an antecedent for a lexical anaphor. Although this is true in cases such as (i), it does not hold for (ii):

(i) *re'iyat 'acma_i 'et ha-mora_i
 view herself OM the-teacher
 'the-teacher's view of herself'

(ii) dan her'a 'et ha-tinoket_i le-'acma_i ?
 Dan showed OM the-baby to-herself

Note, however, that the reverse situation, in which the 'et phrase contains the anaphor and the PP contains the antecedent, is grammatical as well:

(iii) dan her'a la-tinoket_i 'et 'acma_i ?
 Dan showed to-the-baby OM herself

For (ii) and (iii) a strong precede condition holds. Thus compare (ii) and (iii) with the ungrammatical (iv) and the very marginal (v):

(iv) *dan her'a le-'acma_i 'et ha-tinoket_i
 Dan showed to-herself OM the-baby

(v) ??dan her'a 'et 'acma_i la-tinoket_i
 Dan showed OM herself to-the-baby

It seems that in cases in which no clear c-command relationship can be established, a certain precede principle combined with a thematic hierarchy may still render anaphoric coindexing grammatical (see

Jackendoff (1972) for some discussion of the thematic hierarchy).

There are, in fact, some cases in which the combination $\overset{V}{s}el + cl_i [e]_i$, as in (39)b, can serve as an antecedent for a lexical anaphor. These are cases of precede and of thematic superiority of the object of $\overset{V}{s}el$. Thus compare the sentences in (vi)a-b, (vii)a-b:

- (vi)a. ha-xašiva $\overset{V}{s}el$ rina_i 'al 'acma_i
 the-thinking of Rina about herself
 'Rina's thinking about herself'
- b. ha-xašiva $\overset{V}{s}el-i_i$ 'al 'acmi
 the-thinking of-me about myself
 'my thinking about myself'
- (vii)a. ha-xašiva 'al 'acma_i $\overset{V}{s}el$ rina_i
 the-thinking about herself of Rina
 meaning as in (vi)a
- b. *ha-xašiva 'al 'acmi_i $\overset{V}{s}el-i_i$
 the-thinking about myself of-me
 meaning as in (vi)b

In cases (vi)a and (vii)a rina c-commands 'acma 'herself'. Thus we expect considerations of precede to be irrelevant and, indeed, changing the order of the constituents, as in (vii)a, is irrelevant to the grammaticality of the sentence.

In (vi)b, on the other hand, the empty category corresponding to \bar{N}_i in (39)b does not c-command the reflexive anaphor since it is part of a branching structure. Nevertheless, an anaphoric relationship is possible due to precede and due to the thematic superiority of the object of $\overset{V}{s}el$: it is perceived as the agent, whereas the anaphoric expression is perceived as the patient. However, in (vii)b, where

the precede relationship is destroyed, anaphoric relationships are no longer possible, since the empty category under \bar{N}_1 does not c-command the anaphoric expression on the one hand, and it does not precede it on the other. Hence (vii)b is ungrammatical.

11. Interestingly, cases of nominal pied-piping in Rumanian seem to violate Kayne's generalization. Note that in (51)b, pe does not appear preceding the fronted element, although this NP is doubled. The insertion of pe preceding ale carui rezultate 'whose results' would lead to ungrammaticality, since 'whose results' is not [+P] in the sense discussed in section 3.2 above. I would like to suggest that the only grammatical derivation of (51)b thus involves Case assignment to ale carui rezultate in the base prior to the extraction and a defective application of clitic spell-out in the following way:

$$(i) \quad [V \text{ V}, \alpha \text{ Case}] \longrightarrow [V^V, [\beta \text{ number}, \gamma \text{ person}, \delta \text{ gender}]]$$

The application of (i) is defective since the clitic form which is inserted in (i) does not contain Case features. These are assigned to 'whose results' in the usual way. A full, non-defective application of (i) would result in absorption of the Case features of V and thus in the absence of Case marking for 'whose results' and thus in a violation of the Case filter. On the other hand, a complete failure of (i) to apply, even in its defective form, would result in a violation of the semantic requirement on doubling: we will have a non-doubled NP which is [+specific/+ β gender, γ number, α person].

Given this situation, we expect (51)b to be a marked configuration

and indeed, it is somewhat marginal for most speakers and impossible for the others.

12. It may be interesting to return briefly at this point to the question of redundant proper government. In chapter 2, footnote 23, we speculated that the reason that clitics on verbs disappeared in Modern Hebrew is that verbs are proper governors. We noted that when a clitic is attached to a verb the empty category following it is properly governed twice, and thus redundantly so. Note that if we assume that the spell-out of Case features in the base is entirely free, and that other mechanisms, applying at a later stage, rule out ill-formed outputs, then in contexts where proper government is needed following a verb, it will never be the case that a failure to generate a clitic will be ruled out due to lack of proper government: the output would always be grammatical due to proper government by the verb. Given this situation, it seems that in Modern Hebrew this redundancy strongly encouraged the disappearance of clitics on verbs. In Rumanian, the same situation holds with respect to proper government: an empty category in post-extraction cases is always properly governed twice. This redundancy is irrelevant in Rumanian, however, since doubling encodes non-redundant information as well. As was shown earlier, doubling provides crucial information for semantic mechanisms related to [+P] contexts.

13. Throughout the following sections we will be tacitly assuming that verbs have dative assignment features (rather than assuming, for instance, that verbs subcategorize for a PP, regardless of the Case which the preposition assigns). This assumption will be discussed in greater detail in section 4.3 below.

14. Note that we assume that in causative constructions the subordinate clause is S rather than \bar{S} . To the best of our knowledge, there is no direct evidence against this assumption. In fact, in many investigations of causative constructions, it is suggested that following the preposing rule, the lower clause is completely destroyed (Aissen (1974), Rivas (1977)). For our purposes, the assumption that it is S rather than \bar{S} is crucial, since a maximal projection (we take S to stand for $\overline{\text{INFL}}$ and \bar{S} to stand for $\overline{\overline{\text{INFL}}}$; see chapter 1 for discussion) would block government of the subject position José by the matrix verb. Insofar as our analysis accounts for causative constructions in a natural way, it supplies evidence for S vs. \bar{S} in this position.

15. Rivas (1977) observes that a sequence of two a phrases, as in (57)b, is not felicitous. Following Rivas, we take this constraint to be stylistic in nature. Thus if one of the a phrases is fronted, the sentence loses its awkwardness:

(1) a José_i, María le_i hizo escribirles_j a los chicos_j

(See appendix to chapter 3 for some discussion of a similar constraint in French.)

16. It is possible that the requirement that a verb should govern its complement at S-structure should be relaxed to allow the trace of a fronted verb to satisfy this requirement. Although for RP Spanish such modification is not necessary, it may be necessary for French (see appendix to ch.3 for discussion). As will become apparent from the text, the obligatoriness of the fronting of all strictly subcategorized complements in RP Spanish will follow even if the trace, rather than the antecedent verb, can satisfy the requirement that a head should govern its complements. As will be shown below, following reanalysis, the verb hacer has to govern the subcategorized complements of V_2 , thus rendering the fronting of the subcategorized complements obligatory.

17. Jaeggli (1980) argues that, in Spanish, PP's are indeed generated under \bar{V} rather than under $\bar{\bar{V}}$. In this way, the fact that they front along with a direct object is accounted for, assuming that the fronting rule applies only to \bar{V} . Although we accept this as a possible structure, we would like to claim that PP's can in fact be generated under $\bar{\bar{V}}$ as well. Their fronting in causative constructions in this case will be blocked by independent factors (and see text for discussion).

18. The proposal to account for the Case assignment properties of causative constructions by equating them with the Case assignment properties of certain verbal paradigms is due to Wehrli (forthcoming). Wehrli notices that the same situation holds in French. Thus we have the sentences in (i) and (ii) below contrasting with those in (iii) and (iv):

- (i) a. Marie a servi la soupe à Pierre
'Marie served the soup to Pierre'
b. Marie lui a servi la soupe
c. Marie l'a servie à Pierre
- (ii) a. Jean a volé le livre à Pierre
'Jean stole the book from Pierre'
b. Jean lui a volé le livre
c. Jean l'a volé à Pierre
- (iii) a. Jean a servi Pierre
b. *Jean a servi à Pierre
c. Jean l'a servi
d. *Jean lui a servi
- (iv) a. Jean a volé Pierre
b. *Jean a volé à Pierre
c. Jean l'a volé
d. *Jean lui a volé

19. (62)b is in fact grammatical for speakers of the leismo dialect, briefly mentioned in section 4.2 below. For these speakers, accusative clitics can be replaced freely with the dative clitic le. For non-leismo speakers, however, (62)b is ungrammatical

20. Several issues should be clarified with respect to the rules (64) and (65). First, note that (64) is not a local rule, according to our definition of local rules suggested in chapter 1, section 2. The rule specifies an environment which is not affected by it: X which contains a complement of the verb. It is precisely this non-local relationship which holds between the verb which has a dative Case assignment feature, and the complement which is assigned dative, that necessitates the introduction of a rule such as (65), which assigns dative locally.

While (65) is formulated quite freely, its application is subject

to a checking mechanism that would rule out the output unless it matches a dative Case feature of the head verb. In this sense, the dative assigning verb can be said to trigger the application of dative insertion in (65). The nature of the checking mechanism that ensures a dative complement for every dative assigning verb and vice-versa is not explored in this study. Similarly, we will not elaborate on the nature of rule (64). Note, however, that in a sense, the environment specified in (64) could be regarded as an environment which "activates" the potential dative features of the verb, rather than forms them. Perceived in this fashion, rule (64) bears strong similarities to the process which activates genitive Case and which was described in chapter 1, section 2.1.

One could argue that the postulation of two rules (64) and (65) rather than one dative assigning rule is unnecessary. Note, however, that one rule seeking to capture the relationship between the rule and the dative complement will not be strictly local in the sense described in chapter 1.

Rule (65) which equates dative Case assignment in causative constructions with dative Case assignment in simplex sentences is reminiscent of suggestions in Bordelois (1974). Note, however, that we differ from Bordelois in assuming that the assignment of dative is first and foremost a property of the verb which is checked against the application of a local rule, rather than a structural rule assigning dative to an NP in a particular string. Assuming that the assignment of dative is a property of the verb then enables us to greatly simplify the statement of the rule in (65).

21. As we will see in section 4.2 below, in the dialect which we call RP Spanish A, the subordinate subject marked by a will always be dative, since in this dialect a always assigns dative Case. This, however, is not relevant to our point. It will be argued below that, regardless of the Case-assignment properties of a, the verb in direct object configurations has accusative Case assignment features. The dative marking of direct objects is a side effect of the use of the preposition a as an object marker and of the fact that a has dative Case assignment properties even when it appears in an accusative environment. With respect to the causative constructions, that would imply that, although hacer has accusative Case features and satisfies the environment for (63) and for (64) when X is present, the accusative Case will still never be realized, due to the intervening effect of dative a.

22. Rivas (1977) observes that the attachment of clitics to V_2 and V_1 is partially determined by semantic considerations. Thus if the clitic is inanimate, it is preferable to attach it to V_1 . On the other hand, if the subject is present and the object clitic is animate, it has to be attached to V_2 . This is exemplified by the following sentences:

(i) María le hizo escribirle
'María made him write to him'

(ii) *María {^{le}/_{se}} le hizo escribir

(iii) ?María le hizo tocarla
'María made him play it'

(iv) María se la hizo tocar

In (i)-(ii) the complement of V_2 is animate (him) and thus it has to be attached to V_2 . In (iii)-(iv) it is inanimate (it) and thus it is preferably attached to V_1 . I believe that this state of affairs can be explained if we bear in mind that RP Spanish is a clitic-doubling language and that in (i)-(iv) the subordinate subject has a corresponding clitic which is attached to V_1 . The availability of two animate clitics attached to V_1 would result in an ambiguity, but not the situation in which one of the clitics is inanimate: pragmatically speaking, the causee will usually be animate. Rivas further observes that certain clitic combinations are blocked. In particular, if a dative subject clitic is attached to V_1 , then, of the following possible combinations, only (a)-(d) are grammatical:

(v) a.

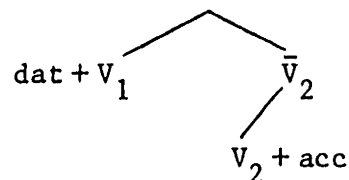

b.

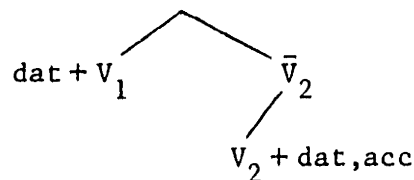

c.

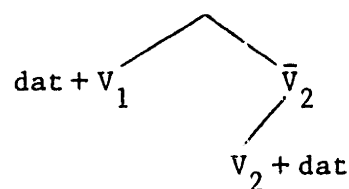

d.

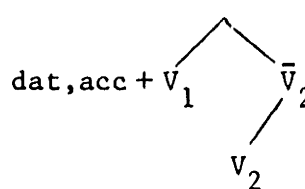

e.

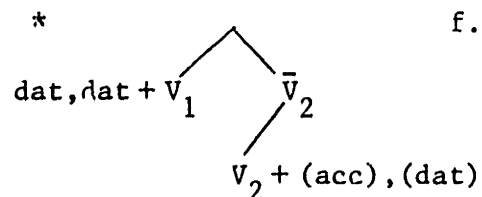

f.

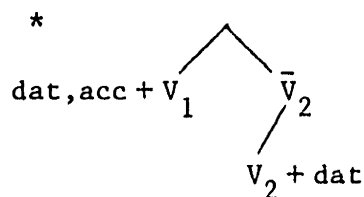

Combination (e) is grammatical only if the clitic which corresponds to the complement of V_2 is inanimate. The explanation of this fact was discussed above. As for the ungrammaticality of (f), it seems to derive

from a constraint that blocks crossing lines between clitics and the gaps which correspond to them, as is demonstrated in (vi):

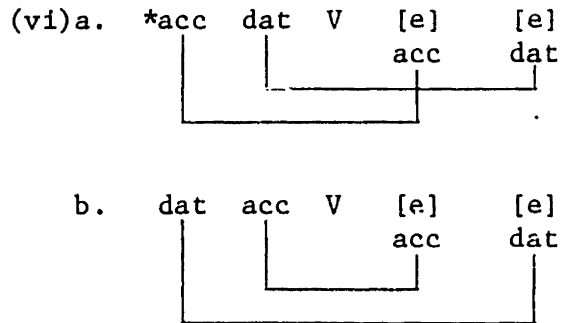

In (f) the situation is as in (vii):

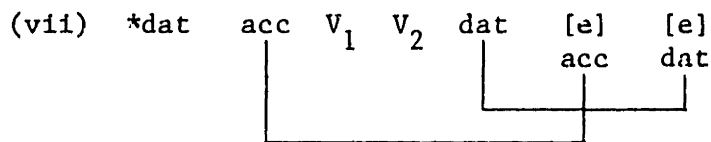

Since the fronting of the accusative clitic alone will create crossing lines, the sentence is ungrammatical.

23. The other logically possible combinations are blocked by the constraints discussed in footnote 22 above. The marginality of $cl_d + V_1 V_2 + cl_a$ combination is explained by the preference for attaching inanimate clitics to the higher verb discussed in footnote 22.

24. For the extension of this analysis to French causatives, see appendix to chapter 3.

25. For another proposal for reanalysis in terms of Case assignment features, see Zubizarreta (1979b).

Note that our analysis crucially applies only to accusative and dative clitics in French. Thus, although we predict that these clitics will never be attached to the lower verb, our analysis makes no claim

with respect to the clitics en and y or the reflexive se. Some comments on the nature of se were included in the appendix, chapter 2. However, we say nothing in this study about the PP clitics en and y. Note that in many respects they differ from accusative and dative clitics: first, they cannot be described as spell-out of Case features or as an insertion of gender, number and person features. Second, even in those dialects of French and Italian which allow for doubling, doubling is never attested with PP clitics. Further, it cannot be said that these clitics are subcategorized by the verb, hence we do not expect the Complement Matching Requirement or government to be relevant for these clitics. In fact, it seems that the best characterization of these clitics is indeed as pronominal elements moved and adjoined to the verbal element.

An exception to these statements are cases when, for example, the clitic y actually corresponds to subcategorized elements, as in (ii):

- (i) j'ai pensé à Pierre
- (ii) j'y ai pensé
- (iii) *je lui ai pensé

We shall return briefly to these constructions in section 3.4 below.

26. Note that in (81) we assume that the subordinate clause is dominated by \bar{S} . Recall that for causative constructions we assumed that the subordinate clause is dominated by S, thus enabling government of the subordinate subject. This situation should be blocked in (81), since the subject position is occupied by PRO.

27. Rivas observes that the same restrictions on clitic distribution which hold in causative constructions hold in 'permit' type verbs. For an explanation of these restrictions, see footnote 22 above.

28. I am indebted to M-L Zubizarreta and Y. Aoun for pointing these sentences out to me. C. Otero has pointed out to me that there is yet another leísmo dialect, in which the substitution of accusative clitics by dative ones is obligatory and in which extraction is nevertheless blocked. This dialect, call it RP Spanish C, is not accounted for in this study.

29. That a is an accusative Case assigner is assumed, in fact, by most of the references cited above on KP Spanish. However, only Jaeggli assumes this for RP Spanish A; thus only with respect to his study is this assumption relevant to our discussion. As will be shown below, we will adopt the assumption that a is an accusative marker for all dialects of Spanish except for RP Spanish A.

30. Lebanese Arabic seems to be a counterexample to our analysis. In this language, clitic doubling in verbs is attested with the insertion of the preposition la 'to' which seems to be a dative marker. Nevertheless, extraction is possible. This is illustrated by (i) and (ii):

(i) $\overset{v}{sift-o}_i$ la-Karim_i
 saw-you-him_i to-Karim_i
 'you saw Karim'

(ii) (la) 'ayya walad_i $\overset{v}{sift-o}_i?$
 (to) which boy saw-you-him
 'which boy did you see?'

- (iii) $\overset{V}{\text{šift-o}}_i$ la-kill walad_i
 saw-you-him to every boy
 'you saw every boy'

(Aoun, forthcoming)

We would like to suggest that in Lebanese Arabic the distinction between accusative Case and dative Case is eliminated. Rather, we have a distinction between nominative Case on the one hand and objective Case on the other hand. The trace left by WH movement in (ii) and by QR in (iii) is thus objective rather than dative; therefore it can be properly governed by an objective clitic attached to the verb.

31. Jaeggli (1980) argues that indirect objects in RP Spanish are in fact PP's, and that, as such, they differ from indirect objects in French. Jaeggli supports his claim with two sorts of evidence. First, he indicates that conjoined NP's can serve as an object of a in RP Spanish but not as objects of à in French (cf. (101)a above). As will become clear below, we offer another explanation for this fact. The second piece of evidence is the fact that in causative constructions, subcategorized PP's are fronted with the fronted V constituent in RP Spanish, but not in French. Assuming that PP complements are generated under \bar{V} , but that indirect NP complements are generated under $\bar{\bar{V}}$, and further assuming that V-fronting in causatives always moves \bar{V} , the fact that indirect objects are fronted in Spanish but not in French follows. The sentences which illustrate this contrast are given in (i)-(ii):

- (i) *je faisais téléphoner à ses parents (à) Jean
 'I made Jean call his parents'

- (ii) le hicimos llamar a sus padres a Pedro
'we made Pedro call his parents'

(Sentence (ii) is, in fact, marginal, due to the restriction against two adjacent a phrases in RP Spanish; see footnote 15 and discussion in the text below.)

Note, however, that in French, indirect objects which are clearly PP's can be left behind:

- (iii) je faisais parler Jean de Marie
'I made Jean talk about Marie'

In the appendix to chapter 3, we return briefly to the ungrammaticality of (i) and to French causatives in general. We show there that the differences between causative constructions in French and in RP Spanish do not depend on the categorial status of the indirect object.

Jaeggli argues that the availability of doubling in indirect objects in RP Spanish but not in French follows from the different categorial nature of the indirect object in these two languages. Although our attempt to account for the same phenomenon is inspired by this idea, we reject the conclusion that the categorial status of the indirect objects differ. Rather, as we will argue below, the nature of the dative Case assignment is different. In RP Spanish it is assigned by a real P, whereas in French it is not. Rather than assume, then, that indirect objects are PP's in RP Spanish, we assume that they are marked as dative by an adjoined preposition.

CHAPTER 4: ON THE INTERACTION OF CLITICS AND PRO-DROP

In the previous chapters we argued for a particular analysis of clitics. It was shown that clitics are best characterized as spell-outs of Case, gender, number and person features which are attached to the head of a phrase and are syntactically part of that head. It was further argued that such clitics cannot be regarded as satisfying subcategorization or complementation requirements; rather, the complement node is independently generated. Given such an analysis, the requirement that coindexing hold between the clitic and the doubled element (if such an element appears), and the requirement that the clitic govern the doubled element, follow from general properties of complementation which have been formulated as the Complement Matching Requirement.

In this chapter, I will extend the analysis proposed above to existential sentences in Modern Hebrew. It will be shown that in this configuration, clitics show an interesting interaction with the pro-drop phenomenon. Section 1 on this chapter contains a presentation of existential sentences in Hebrew, indicating that clitics in these constructions behave both as agreement markers and as object clitics. Section 2 contains an analysis of the pro-drop phenomenon in Hebrew, motivating a change in the analysis of pro-drop discussed in Chomsky (1981). Sections 3 and 4 include the nominative and the accusative derivations of existential sentences in Hebrew, while elaborating on the consequences that these constructions have for the theory of grammar.

1. Presentation of the Problem

Existential sentences in Modern Hebrew are formed by using the particle yes^v 'exist' to assert existence and the particle 'eyn 'exist not' to negate

existence:

- (1) $\overset{v}{ye\check{s}}$ $\overset{v}{\check{s}lo\check{s}a}$ $xatulim$ $ba-gan$
 exist three cats in-the-garden
 'there are three cats in the garden'
- (2) $'eyn$ $\overset{v}{\check{s}lo\check{s}a}$ $xatulim$ $ba-gan$
 exist-not three cats in-the-garden
 'there aren't three cats in the garden'

Sentences (1)-(2) exhibit a typical behaviour for existential sentences in that the NP whose existence is being asserted, the understood subject, cannot be definite and appears in the predicate, and not in the subject position. The definiteness restriction is demonstrated in (3)-(4) (and see Milsark, 1974 for some discussion of the definiteness restriction in existentials):

- (3) $*\overset{v}{ye\check{s}}$ $\overset{v}{\check{s}lo\check{s}et}$ $ha-xatulim$ $ba-gan$
 'there are the three cats in the garden'
- (4) $*'eyn$ $\overset{v}{\check{s}lo\check{s}et}$ $ha-xatulim$ $ba-gan$
 there aren't the three cats in the garden'

The sentences (1)-(4) have counterparts in which the subject appears in the regular subject position. In these cases, the subject can be definite or non-definite (and again, compare with the English counterpart). Interestingly, in these cases a clitic is obligatory attached to the particle. This clitic agrees in gender, number and person with the subject:¹

- (5)a. $\overset{v}{\check{s}lo\check{s}a}$ $xatulim$ $\overset{v}{ye\check{s}-nam}$ $ba-gan$
 three cats exist-they in-the-garden
 'three cats are in the garden'
- b. $\overset{v}{\check{s}lo\check{s}a}$ $xatulim$ $'eyn-am$ $ba-gan$
 'three cats are not in the garden'
- c. $\overset{v}{\check{s}lo\check{s}et}$ $ha-xatulim$ $\overset{v}{ye\check{s}-nam}$ $ba-gan$
 'the three cats are in the garden'
- d. $\overset{v}{\check{s}lo\check{s}et}$ $ha-xatulim$ $'eyn-am$ $ba-gan$
 'the three cats are not in the garden'

The requirement that the clitic agrees with the subject in number, gender and person is demonstrated in (6):

- (6)a. 'ani_i 'eyn-eni_i/*no/*nxa ba-gan
 I exist-not-I/*he/*you in-the-garden
 'I am not in the garden'
 b. ha-yalda_i yeš^v-na_i/*no ba-gan
 the-girl exist-she/*he in-the-garden
 'the girl is in the garden'

A failure to attach a clitic to the particles yeš^v and 'eyn when they appear following the subject results in ungrammaticality:

- (7)a. *šloš^vet ha-xatulim yeš^v ba-gan (Compare with (5)c)²
 b. *'ani 'eyn ba-gan (Compare with (6)a)

Similarly, the attachment of a clitic when the subject is not fronted is ungrammatical:

- (8)a. *yeš^v-nam_i šloš^va xatulim_i ba-gan (Compare with (1))
 b. *'eyn-a_i yalda_i ba-gan
 exist-not-her girl in-the-garden
 'there is not a girl in the garden'

At first glance, it seems that the contrast between the grammaticality of (1), (2) and (5) on the one hand, and the ungrammaticality of (7) and (8) on the other hand can be explained by assuming the analysis of clitics illustrated previously. According to this analysis, the clitic would be a spell-out of the Case features of the particle. The particle itself would not be a proper governor. Hence, only when the clitic is present can extraction occur, allowing the coindexed clitic to properly govern the empty position. Thus (7) would be ungrammatical because the extraction site following the particle is not properly governed. (8) would be ungrammatical

because the clitic absorbs the Case features of the particle, hence the NP \bar{V} \bar{V} šloša xatulim 'three cats' would not be assigned Case and would violate the Case filter.

Some independent evidence that particles are not proper governors comes from cases on quantifier raising. Thus wide-scope interpretation of many is impossible in (9)a but possible in (9)b:

- (9)a. 'eyn harbe yeladim ba-gan
'there aren't many children in the garden'
- b. harbe yeladim 'eyn-am ba-gan
'Many children are not in the garden'

A wide scope interpretation for many in (9)a would result in an empty category following 'eyn, as in (10)a. Since 'eyn is not a proper governor, this reading is ruled out and the only possible reading of (9)a is the one in which the negation marker 'eyn has scope over many. (9)b, on the other hand, is given the representation in (10)b:

- (10)a. there is x such that x is many children, 'eyn x in the garden
- b. there is x such that x is many children, x 'eyn+cl_i [e]_i in the garden

If we extend the analysis proposed in the previous chapters to the clitics on the existential particles discussed above, then a few related questions arise. What is the status of the subject position in sentences such as (1)-(2)? How does the fronted element in (5)a-b receive Case? what Case is assigned to the post-particle subject?

Clearly, the Case which is assigned to the fronted subject in sentences such as (5)a-b is nominative. This is shown by the appearance of nominative

pronominal forms in that position, as in (6)a above. Assuming the rule of nominative Case assignment to be roughly as in (11) (but see below for a more precise formulation), we thus conclude that the value of AGR in (5)a-b is [+]:

- (11) Assign nominative to NP if it governed by +AGR

On the other hand, it is also clear that the Case which is assigned to the post-particle position is, again, nominative. This is evidenced by the appearance of nominative pronominal forms in that position as well (note that in regular existential sentences this is impossible, due to the definiteness requirement. However, the particle 'eyn functions in Modern Hebrew as a marker of negation in present tense and nominal sentences, and in these cases, a post-verbal subject is not constrained by the definiteness requirement):³

- (12)a. 'eyn 'ani yoda'at 'et ha-t^vsuva
 neg I know acc the-answer
 'I don't know the answer'
- b. 'eyn hi ha-rof'a
 neg she the-doctor
 'she is not the doctor'

If we wished to maintain the assumption that the clitic in (5) is a spell-out of the Case features of the particle, we would have to conclude that existential sentences contain two nominative markers: the AGR node and the particle itself. But note that if this is the case, we no longer have an explanation for the ungrammaticality of (3): although the Case features of the particle itself were absorbed by the clitic, we would still expect it to be possible for AGR to mark the subject as nominative in the post-verbal position, since nominative assignment by AGR in post-verbal positions is otherwise possible in Modern Hebrew, as is demonstrated by (13)a-b:

- (13)a. huku ^všloša yeladim ba-gan
 were-beaten three children in-the-garden
 'three children were beaten in the garden'
- b. nišmea yilelat xatul
 was-heard wailing cat
 'the wailing of a cat was heard'

Clearly in (13)a-b the post-verbal subject is assigned nominative, since it agrees with the verb in number, gender and person, a characteristic property of nominative Case assignment (for detailed discussion see Borer, 1980a, where it is argued that the verbs in (13)a-b are "ergative" verbs in the sense of Burzio, 1981 -- see also discussion below).

In order to answer the questions posed above and clarify the status of the subject in sentences (1)-(2), it is useful to briefly review pro-drop phenomena in Modern Hebrew.

2. Pro-Drop in Modern Hebrew

Yet another curious property of the particle+clitic complex in sentences which are equivalent to (5) and (6) above is that it behaves exactly like a fully inflected verb with respect to pro-drop.

Pro-drop is the name given to a phenomenon attested in languages such as Italian, Spanish, Rumanian, Arabic, Hebrew and others. In these languages, a pronominal subject is optional. In Hebrew, this phenomenon has an unusual distribution: it seems to be attested only in the past and future tenses and, in those cases, only in the first and second person (but see below for other cases). This situation is exemplified by the following paradigm:

- (14)a. ('ani) 'axalti 'et ha-banana
 (I) ate acc the-banana
- b. 'ani 'oxelet 'et ha-banana
 I eat acc the-banana
- c. *'oxelet 'et ha-banana
 eat acc the-banana
- d. ('ani) 'oxal 'et ha-banana
 will-eat

- (15)a. ('atem) 'axaltem 'et ha-banana
 (you-pl) ate acc the-banana
 b. 'atem 'oxlim 'et ha-banana
 eat
 c. *'oxlim 'et ha-banana
 d. ('atem) toxlu 'et ha-banana
 will-eat
- (16)a. hu 'axal 'et ha-banana
 he ate acc the-banana
 b. *'axal 'et ha-banana
 c. hu 'oxel 'et ha-banana
 eats
 d. *'oxel 'et ha-banana
 e. hu yoxal 'et ha-banana
 will-eat
 f. *yoxal 'et ha-banana

As has been noted before (see Borer, 1980a), the availability of pro-drop in Hebrew seems to be related to the availability of person markers in the AGR node. In the present tense, AGR in Hebrew is defective: it contains markers only for gender and number but not for person. The third person in the other tenses is the unmarked person of AGR in Hebrew. It would thus be plausible to assume that the person marker in these forms is not sufficiently specific and thus cannot "trigger" pro-drop (we return to the formulation of this generalization below).

Returning now to the particle+clitic complex as illustrated in (5)-(6) above, it is interesting to note that it behaves as a fully inflected verb (namely, a non-present tense verb containing a person marker) with respect to pro-drop. Thus (17)a-e are grammatical but (18)a-b are not:

- (17)a. ('ani) 'eyn-eni ba-gan
 'I am not in the garden'
 b. ('ata) 'eyn-xa ba-gan
 'you are not in the garden'

- c. ('atem) 'eyn-xem ba-gan
'you(pl) are not in the garden'
- d. hu 'eyn-enu ba-gan
'he is not in the garden'
- e. hem 'eyn-am ba-gan
'they are not in the garden'
- (18)a. *'eyn-enu ba-gan (Compare with (17)d)
b. *'eyn-am ba-gan (Compare with (17)e)

Clearly, the grammaticality of the pro-drop versions of (17)a-c vs. the ungrammaticality of (18) is related to the clitic on the particle: when this clitic is specified for first and second person, pro-drop applies in a similar way to its application in (14)a,d and (15)a,d. In (18), where the person marker is that of third person, its application is blocked as it is blocked in (16)b,f. However, we concluded earlier that the crucial trigger for pro-drop in Hebrew is related to the person marker in the AGR node. In (17)-(18), on the other hand, the relevant person marker is a clitic on the particle.

These facts would seem to suggest that the clitics on the particles should be viewed as AGR markers rather than as a spell-out of the Case features of the particles themselves. AGR, however, is not a proper governor (see Rizzi, 1980 for discussion). Thus if the clitic is an AGR marker and if the particles themselves are not proper governors (as we concluded on the basis of (9) above), then every extraction from the post-particle position should result in a violation of ECP. The clitic cannot properly govern the empty position, since it is an AGR marker, and the particle itself is not a proper governor. Since extraction is nevertheless possible, and only when the clitic is present, we arrive at the rather contradictory conclusion that the clitics on the particles function as AGR markers

with respect to the pro-drop phenomenon, but as clitics on the particle itself for the purposes of proper government of the post-particle position, when extraction from the latter position takes place.

Chomsky (1981) suggests that the availability of pro-drop in some languages vs. its absence in others (such as English and French) can be explained if we assume that the rule which attaches the AGR markers to the verb (essentially the rule of Affix Hopping of Chomsky, 1957) is a local rule (in the sense of Emonds, 1976, and see chapters 1 and 3 for discussion). This rule can apply either in the syntactic component of the grammar or in the phonological component. Different grammars may select to restrict this option to the phonological component. The rule of Affix Hopping is given in (19) and is restricted for English and French as stated in (20):

(19) Affix Hopping (AH)

AGR V \longrightarrow [_V V, AGR]

(20) AH may not apply in the syntax⁴

(Recall that we are assuming, following Chomsky, 1981, that local rules do not leave a trace.)

Let us now see how this rule accounts for the distribution of pro-drop. Consider the following S-structure representations of sentence (14)a above:

- (21)a. I +AGR [_{VP} ate the banana] AH has not applied in the syntax
 b. I [_{VP} ate+AGR the banana] AH has applied in the syntax
 c. PRO +AGR [_{VP} ate the banana] AH has not applied in the syntax
 d. PRO [_{VP} ate+AGR the banana] AH has applied in the syntax

Representation (21)a is well-formed: the AGR node governs the subject position at S-structure, and thus it can assign nominative Case. This derivation gives rise to the grammatical non-pro-drop version of (14)a. Representation (21)b is ungrammatical: the subject position is not governed by AGR; hence, the lexical NP I cannot receive Case.⁵ Thus this derivation violates the Case filter. Representation (21)c is ungrammatical as well: at S-structure the AGR node governs the subject position, thus yielding a governed PRO and resulting in ungrammaticality. Representation (21)d, on the other hand, is well-formed: since AGR no longer governs the subject position, PRO is free to appear there. In French or English, since AH can only apply in the phonological component, (21)d is never possible; consequently, all representations which include PRO in subject position are ungrammatical.

Chomsky further extends this analysis to account for other phenomena typical to pro-drop languages: empty pleonastic subjects and free inversion of the subject. These constructions in Hebrew and their counterparts in non-pro-drop languages are given in (22)-(24):

(22) Pleonastic elements in "raising" and extraposition configurations:

- a. it seems that John is late again
- b. nir'e ^vše-Itamar ^všuv me'axer
seems that-Itamar again late
- c. it annoys me that John is always late
- d. margiz 'oti ^vše-Itamar tamid me'axer
annoys me that-Itamar always late

(23) Pleonastic elements in "ergative" configurations (in the sense of Burzio, 1981):

- a. il est arrivé un garçon⁶
'there arrived a boy'

- b. nišma^V cilcul pa'amon
 was-heard ring bell
 'bell-ringing was heard' or 'bell-ringing is heard'

(24) Subject inversion:

- a. *ate the apples three men/John and Mary
 b. ??there ate the apples three men/*John and Mary
 c. 'axlu 'et ha-tapuxim šloša 'anašim/Raxel ve-Dan⁷
 ate acc the-apples three men Rachel and Dan

(Note that in (23)b and (24)c the subject position in Hebrew is empty although the AGR node does not contain the person marker which can trigger pro-drop in the sense discussed above. We will return to this point below when we formulate more precisely the functioning of the person marker.)

Two questions can be raised with respect to the pro-drop variants of (22)-(24): first, why are pleonastic elements attested only in non-pro-drop languages? Second, in (23)b and (24)c, how is nominative Case assigned to the post-verbal subject?

Note that the availability of pleonastic elements in non-pro-drop languages follows directly from the existence of restriction (20) in these languages: since the subject position is always governed, it follows that PRO cannot appear there. Since AGR is not a proper governor, it also follows that [e] cannot appear in the subject position. Thus a lexical NP has to appear in this position. Since the position is a non-thematic position, a lexical NP appearing in it has to be non-referential, i.e., pleonastic (and see chapter 1 and the appendix to chapter 2 for some discussion). However, one would expect that, in pro-drop languages, and precisely in those derivations in which AH has not applied in the syntax, such pleonastic elements would show up. In order to explain the absence of such elements, we could invoke the principle Avoid Pronoun of Chomsky (1981). This

principle will effectively force AH to apply in the syntax, allowing for PRO to appear in the subject position.

The Avoid Pronoun principle, however, is not a very strong one. Both expansions of (14)a above, for example, are fully grammatical, although the one in which the full pronominal form 'ani 'I' is omitted, is slightly preferred. Consequently, we would not expect the exclusion of a pleonastic element to be very strong either. Interestingly, there are sentences corresponding to (22)b-d in substandard Hebrew which utilize a pleonastic element:

- (25)a. ?ze nir'e ^Vše-Itamar ^Všuv me'axer
 'it seems that Itamar is late again'
- b. ze margiz 'oti ^Vše-Itamar tamid me'axer
 'it annoys me that Itamar is always late'

However, the counterparts of (23)b and (24)c with the pleonastic element ze are completely ungrammatical:

- (26)a. **ze ni^Všma cilcul pa'amon
- b. **ze 'axlu 'et ha-tapuxim ^Všloša ^V'anašim

As we will see below, there are independent reasons to believe that precisely in these cases AH is forced to apply in the syntax in order to form a grammatical derivation. Thus, assuming that (20) is indeed the parameter distinguishing pro-drop languages from non-pro-drop languages, it will correctly predict the distribution of pleonastic elements in substandard Hebrew.

Let us now turn to the assignment of nominative Case in (23)b and (24)c. We know that nominative rather than any other Case is assigned to the post-verbal subject since the verb has to agree with the subject, whether preposed or postposed. Thus (27)a-b are ungrammatical:

- (27)a. *ni^Všma cilculey pa'amon
 was/is-heard ringings bell
 'ringings of a bell are/were heard'

- b. *'axal 'et ha-tapuxim šloša 'anašim
ate(sg) acc the-apples three men

In order to capture the assignment of nominative Case to post-verbal subjects, Chomsky suggests that at D-structure a rule of superscripting co-superscripts the subject position and AGR. He further suggests that the rule for nominative Case assignment applies at S-structure and is as in (28):

- (28) Assign nominative Case to an NP which is both governed by AGR and co-superscripted with it.

Nominative Case is now assigned to (24)c in the following way: at D-structure, following the co-superscripting, the representation of (24)c is as in (29):

- (29) NPⁱ AGRⁱ [_{VP}.....]

Following the postposing of the subject, the possible configurations at S-structure are as in (30)a-b:

- (30)a. [e]ⁱ AGRⁱ [_{VP} [_{VP}.....] NPⁱ] AH did not apply in the syntax
b. PROⁱ [_{VP} [_{VP} V+AGRⁱ...] NPⁱ] AH applied in the syntax

(30)a is ungrammatical since nominative Case cannot be assigned to the post-verbal NP: although it is co-superscripted with AGR, it is not governed by it and hence (28) cannot apply. (30)b, on the other hand, is grammatical. AGR is attached to the verb and now it governs the co-superscripted NP in the post-verbal position (recall that we are assuming that a head can govern into adjoined structures. See the definition of c-command and government in chapter 2, (42) and (53) above).⁸ From the application of AH in the syntax, it follows that no lexical NP, and thus no lexical pleonastic element, can appear in the subject position, quite independent from the Avoid Pronoun

principle. The appearance of a lexical NP in subject position would be ruled out, since that NP cannot receive Case; hence it would violate the Case filter. Thus (26)b above is ungrammatical.

In order to account for the assignment of nominative Case in "ergative constructions", some more machinery is necessary. Assuming, following Burzio (1981) and Borer (1980a), that in sentences such as (23)b the post-verbal subject is base generated in the VP,⁹ we cannot appeal to superscripting at D-structure as a way to co-superscript AGR and the post-verbal NP.

In order to account for the nominative Case assignment in these cases, Chomsky argues that an expletive PRO which is co-superscripted with the post-verbal subject is inserted in the subject position. Since this PRO is inserted into a position which is co-superscripted with AGR at D-structure by the process described above, it follows, by transitivity of coindexing, that the post-verbal subject is co-superscripted with AGR. Thus the post-verbal subject can be assigned nominative Case once AH has applied in the syntax. Again note that the only derivation which is well formed is the one in which AH applies in the syntax, hence rendering (26)a ungrammatical.

We will assume the analysis of pro-drop sketched above with a slight change: we will assume with Chomsky that there is a rule applying at D-structure which co-superscripts AGR and the subject position. However, we will not assume that the inserted PRO in ergative constructions is co-superscripted with the post-verbal position. Rather, we will assume that every NP can be freely assigned a superscript. However, only if the superscript which is assigned to the post-verbal NP matches that of AGR will the post-verbal NP be able to receive nominative Case.

It seems, however, that the system we propose would not block nominative Case assignment to objects of transitive verbs. Since superscripting is

Our account makes a rather clear prediction: if one could find verbs which violate the generalization above, namely, verbs which assign accusative Case but which do not assign a θ -role to their subject, we would expect some freedom with respect to the assignment of Case to the complements of these verbs. We expect them to be either accusative or nominative, depending on the superscript picked by the post-verbal NP. If that superscript matches that of AGR, we expect nominative Case, otherwise, we expect accusative Case. As we will see in section 4 below, this prediction is verified, thus supplying strong evidence for the free superscripting of post-verbal NP's.

Let us now turn to the function of the person marker in delimiting the pro-drop phenomenon. Let us assume that the person feature of AGR contains a referential index. Naturally, this referential index is present only when the person feature is present. Thus in present tense in Hebrew there is no such index. The 3rd person marker, we assume, is defective in that it does not contain such a referential index. Thus the only person markers which contain referential indices are 1st and 2nd person markers. Now let us assume that, in configurations such as (32), the referential index is obligatorily transmitted to a lexical NP in the subject position as part of the superscripting process (outlined above) between AGR and the subject position (we will take PRO's which are present at D-structure, to be lexical):

(32) PROⁱ AGRⁱ
 NPⁱ gender
 number
 person_j

Note that in the cases in which the subject position is null at D-structure (such as the ergative cases and the pleonastic cases in (22) and (23) above) this transmission of a referential index will not take place. However, it will apply in the standard cases of pro-drop, such as the ones in (14)a-b,d

There are, in fact, two other ways to assign a referential index to a PRO. First, it can be assigned a referential index by a controller and second, it can have arbitrary reference. And indeed, (33)c-d can be "salvaged" in these situations. In (34)a-b a control situation is illustrated. In (35)a-b the PRO has arbitrary reference:

- (34)a. Talila_i ma'amina ^vse-PRO_i hiclixa ba-bxina
 Talila_i believes that PRO_i succeeded in-the-test
 'Talila believes that she passed the test'
- b. Dani bikes^v me-Talila_i ^vse PRO_i tavo¹²
 Dani asked from-Talila_i 'nat PRO_i will-come
 'Dani asked Talila to come'
- (35)a. 'amru 'et ze ba-radio 'etmol
 said(pl) it in-the-radio yesterday
 'it was said on the radio yesterday'
- b. 'omrim ^vse-Rina lo hiclixa ba-bxina
 say(pl) that-Rina not succeeded in-the-test ¹³
 'it is said that Rina did not pass the test'

When no referential index is assigned to PRO, it is a non-referential PRO, a pleonastic one. Since it is not a referential expression, its distribution is restricted by the θ -criterion. Thus we find this PRO in "raising"-type constructions, in "extraposition"-like constructions and in the subject position of ergative verbs. This situation was illustrated by (22)-(23) above. Note that, typically, the verbs in these constructions appear in the present tense and in the third person, failing to transmit a referential index (and see footnote 11 above for some comments on index transmission in these cases).

Following our analysis of pro-drop in Hebrew, only in (38)a is the PRO assigned a referential index by the 1st person marker in the clitic. On the other hand, in (38)b the person marker is 3rd person, and hence does not transmit a referential index to PRO. PRO, on the other hand, cannot be arbitrary, because the clitic is not 3rd person, masculine plural,¹⁴ and it is not controlled. It follows that PRO cannot receive a referential index. (38)b is therefore ungrammatical.

Given this account, it is desirable to argue that the clitic attached to the particle is, in some sense, an agreement marker. On the other hand, recall that it functions as a proper governor for a position inside the Particle Phrase (PtP). From this point of view, it is desirable to claim that it is a clitic rather than an AGR marker. Only clitics are proper governors; AGR markers are not.

In order to settle this apparent contradiction, let us assume the following:

1. Particles are "ergative" verbal elements in that their subject follows them in the PtP. Like other "ergative" verbs, they do not assign Case to their subject. Rather, the subject is assigned Case by AGR once AGR moves into the PtP and adjoins to the Particle (Pt). However, unlike genuine "ergative" verbs, particles are not proper governors. Thus, an empty category following the particle is not properly governed unless a coindexed clitic is present.
2. In spite of the fact that particles do not have Case features, the rule of Clitic Spell-Out may optionally apply in particle constructions, although in a defective way. Its application will be as in (39):

(39) $[_{Pt}Pt] \longrightarrow [_{Pt}Pt, [\alpha \text{ gender}, \beta \text{ number}, \gamma \text{ person}]]$

The clitic formed by (39) is defective in that it does not contain the feature [δ Case]. Let us assume that the output of (39) is ruled out by a phonological filter, unless the feature [δ Case] is added to the matrix of features of the clitic at some point of the derivation to yield the grammatical clitic representation in (41):

(40) $[\alpha \text{ gender}, \beta \text{ number}, \gamma \text{ person}, \delta \text{ Case}]$

Intuitively speaking, our proposal implies that although the representation in (39) counts as a clitic for the purposes of proper government and the interpretative component, it cannot be regarded as a well-formed clitic in PF unless it contains the feature [δ Case].¹⁵ Thus once (39) has applied, the derivation is ruled out unless there is a way to add the missing Case feature to the clitic derived by (39).

Another assumption needed with respect to the particles ye^v and 'eyn in general is that they can never vary, regardless of the nature of AGR in these cases. In this way, they differ from regular verbs. The latter may vary morphologically, depending on the value of AGR when it is attached, and incorporate gender, number and person information. On the other hand, we will assume that even when AGR is specified for particular gender, number and person information, this information will never be realized phonologically when it is attached to the particle, since the morphological pattern associated with particles is defective.

Now let us consider the derivation of (36)-(38) above. The derivation of (36)a is quite straightforward. In this case, AH applies in the syntactic

sentence is ruled out twice.

Now let us consider the derivation in which the post-verbal subject has been fronted to the subject position, but (39) above has not applied. The output is as in (43):

(43)(=37)b * NP_i^j AGR^j [_{PtP} Pt [e]_i]

In (43) NP_i^j was moved to the subject position, leaving behind a coindexed trace. Although NP_i^j can be assigned nominative Case by the governing, co-superscripted AGR, the derivation is nevertheless ungrammatical, since the empty category left following the fronting of the post-verbal NP is not properly governed (recall that the particle itself (Pt) is not a proper governor).

Now consider a derivation in which (39) has applied, AH has applied in the syntax and the post-verbal subject has not been fronted. This derivation is given in (44):

(44)(=37a) * PRO^j [_{PtP} Pt + cl_i + AGR^j NP_i^j]

In (44) (39) has applied, resulting in a clitic attached to the particle, which is coindexed with the complement NP_i^j . We further assume a derivation in which AH has applied in the syntax and in which the post-verbal NP is assigned the same superscript as AGR. (note that if in (44) AH does not apply in the syntax, the sentence will be ruled out for the same reason that (42) above is ruled out. Furthermore, if the post-verbal NP is not assigned the same superscript as AGR, it cannot receive Case; see discussion above.) (44) is nevertheless ungrammatical. Recall that after the application

of (39) above, the clitic is defective; unless a Case feature is added to it, it will be ruled out. In (44), the addition of the missing Case feature is possible: the clitic can absorb the nominative Case feature of AGR which is now attached to the particle. However, after the absorption of this feature, the assignment of nominative Case to the post-verbal NP^j is no longer possible. Since NP^j cannot receive Case in any other way, the derivation is ungrammatical.

If, on the other hand, there is no post-verbal NP which has to be assigned nominative Case in cases such as (44), we expect the derivation to be grammatical. Thus, corresponding to (44) and (37)a we have the grammatical sentence in (38)a -- the case of pro-drop:

(45) (=38a) PRO_i^j [PtP Pt + cl_i AGR^j [e]_i]

Let us consider in detail the derivation of (45). At D-structure, the structure of (45) is assumed to be as in (46)a:

(46)a. [NP]^j AGR^j [PtP Pt PRO]_i¹⁶
 [1st person]_i

(Note that we are assuming that the value of the person marker of AGR in (45) is [1st person]. We will return below to the motivation of this assumption.)

Two operations apply to (46)a: first, the post-verbal PRO is assigned a superscript at random. At this stage, however, there is no reason to assume that the superscript 1 which is assigned to PRO is identical to j, the superscript of AGR and of the null category in the subject position.

Second, (39) above applies, resulting in a clitic which is coindexed with the complement PRO. These two operations result in the structure in (46)b:

$$(46)b. \quad \left[\begin{array}{c} \text{NP} \\ \text{AGR}^j \\ \text{[1st person]}_i \end{array} \right]^j \quad \left[\begin{array}{c} \text{PtP} \text{ Pt} + \text{cl}_k \\ \text{PRO}_k^1 \end{array} \right]$$

Again, a few processes apply to (46)b. First, by the application of "Move α ", the post-verbal PRO is moved to the subject position, leaving behind a coindexed empty category. (Note that the failure of "Move α " to apply in this case would result in a governed PRO at S-structure, and hence in ungrammaticality.) If PRO_k^1 is moved to $\left[\text{NP} \right]^j$ and $l \neq j$, the derivation is ruled out. Hence the only grammatical derivation in this respect is the one in which $l=j$. Note that PRO now carries the same superscript as AGR. Let us assume that, as such, it also has to have the same subscript as AGR, if AGR contains a subscript. Since in (46) it does, we conclude that $k=i$ and that the correct representation of PRO in (46) is as PRO_i^1 .

Second, in (46)b AH applies in the syntactic component. Again, the failure of AH to apply in the syntactic component will result in a governed PRO in subject position, thus placing the sentence in violation of the binding conditions. The application of "Move α " and AH in the syntax results in the representation in (46)c:

$$(46)c. \quad \text{PRO}_i^j \quad \left[\begin{array}{c} \text{PtP} \quad \left[\text{Pt} + \text{cl}_i + \text{AGR}_i^j \right] \\ \left[e \right]_i \end{array} \right]$$

Following the attachment of AGR to the particle, nominative Case is absorbed by the clitic, thus rendering the clitic well-formed, as required by (40) above.

Let us try to be more specific about the nature of the absorption of the nominative Case. Let us assume that, in fact, the full AGR node is

absorbed by the clitic, including the (separate) set of gender, number and person features which the AGR node contains. A natural assumption would be that such an absorption is only possible if the set of features generated by the rule (39) above is identical to the set of features which the AGR node contains. Otherwise, the absorption would result in a conflict and hence in ungrammaticality. Thus, the fact that in (38)a above the clitic is [1st person sg] clearly indicates that AGR in (38)a is [1st person sg] as well. Any other combination would result in ungrammaticality: the absorption of a conflicting set of features would be ill-formed. On the other hand, the failure of absorption to apply would result in an ill-formed clitic, violating (40) above, and leading to ungrammaticality.

(46)c above contains an empty category, which is properly governed by the coindexed clitic. The clitic, an output of rule (39), is well-formed, since nominative Case has been absorbed, hence it is a well-formed representation, in accordance with (40). AGR has moved into the PtP in the syntactic component, resulting in an ungoverned PRO in subject position. There thus remains no reason to rule the sentence in (38)a out -- and, indeed, it is grammatical.

Let us now turn to the last case, the one illustrated by (36)b above. In this case, AH applies in the phonology; thus, nominative Case can be assigned to the fronted NP in the subject position. On the other hand, (39) applies as well, resulting in a clitic which governs the empty category left by the preposed subject and is coindexed with it. Thus at S-structure the structure of (36)b is as in (47):

(47)(=36b) NP_1^j AGR^j [_{PtP} [_{Pt} Pt + cl₁] [e]₁]

The clitic in (47) is defective, in that it does not contain a Case feature. Recall, however, that we assume that the well-formedness condition for clitics applies in the phonological component. Thus, for the LF component, (47) is well-formed: NP_1^j is assigned nominative by AGR and the empty category is properly governed by a coindexed, governing clitic.

In the phonological component AH applies, attaching AGR to the particle. As such, it supplies the missing feature for the clitic: nominative Case. Hence in the phonology, once the feature Case has been added, the derivation is well-formed, and the clitic adheres to the description in (40) above.

Note that we are crucially assuming that in the phonological component, once AGR is moved to the PtP and is attached to the particle, it still contains the nominative Case features. It can thus still supply the missing Case feature to the defective clitic in (47), rendering the clitic well-formed. This nominative Case feature is still part of AGR, although nominative Case has been assigned at S-structure to NP_1^j in (47). The fact that AGR still contains nominative Case features after nominative Case has been assigned supplies further evidence for the difference between the assignment of nominative Case and the assignment of other Cases. Recall that the local rules of Case assignment as discussed in chapter 1 section 2 required adjacency. Nominative Case does not require adjacency, as is attested by the assignment of nominative Case to postposed subjects (and see (24)c above). The local rules of Case assignment do not require superscripting, whereas nominative Case assignment does. We thus conclude that the assignment of nominative Case is not a local rule, and that unlike local rules of Case assignment it does not involve the transference of a feature. Instead, we

will assume that nominative Case is copied onto the co-superscripted, governed element. Thus nominative Case is still present in the phonological component as part of AGR and it can supply the missing feature for the clitic in (47).

4. Existential Sentences -- The Accusative Derivation

Interestingly, some occurrences of the existential particles in Modern Hebrew are currently undergoing a process of reanalysis. This is particularly true of all the uses of particles in which no true existential meaning is expressed. Thus alongside the sentences in (36) and (37) above we have the following:¹⁷

- (48) 'eyn 'et ha-sefer ha-ze ba-sifriya
 exist-not acc the-book the-this in-the-library
 'this book is not in the library'

Clearly (48) indicates that the particle 'eyn in cases such as (48) functions as an accusative-assigning particle. Furthermore, when the particles function as accusative assigners, they allow for extraction from the post-particle position without the presence of a coindexed clitic. Thus (49) and (50) are possible:

- (49) 'et ma_i yeš^v [e]_i ba-sifriya?
 acc what exists in-the-library
 'what is there in the library?'
- (50) yeš^v 'et šlošet^v ha-sfarim še-xipasta^v ba-sifriya
 exist acc three the-books that-searched-you in-the-library
 'the three books that you were looking for are in the library'

In (49), extraction took place with the accusative marker 'et, leaving an empty category in the position following the particle. In (50), 'three books' receives wide scope interpretation.

Interestingly, fronting of the object of the particle into the subject position once accusative Case is assigned is impossible. Thus (51)a has only a topicalized reading, and (51)b is ungrammatical:

- (51)a. sifrei yeladim yeš^v ba-sifriya, sifrey mevugarim, lo
 books children exist in-the-library books adults no
 'there are children's books in the library, but not adults' books'
- b. *sifrey ha-yeladim yeš^v ba-sifriya etc.
 books the-children
 'the children's books are in the library etc.'

We believe that the sentences in (48)-(51) can be explained if we assume that particles in Modern Hebrew are being reanalyzed as accusative Case assigners. The assignment of accusative Case is optional. However, when the particle does assign accusative, it completely assimilates to the verbal class. In particular, it can function as a proper governor without the presence of an attached clitic coindexed with the empty category. Thus the representation given in (52) is grammatical in the accusative derivation:

- (52) [_{PtP} Pt [e]]
 [+acc]

The configuration in (52) is in fact the representation of both (49) and (50) at the stage at which ECP is relevant. The availability of proper government in (52) thus renders (49) and (50) grammatical.¹⁸

Recall now that we argued that the superscripting of the NP in the VP in "ergative" constructions is random. Only if the superscript assigned to the NP in the VP (or in our case, in the PtP) agrees with the superscripting of AGR can the post-verbal NP receive nominative Case. This

occurs when AH applies in the syntax and AGR both governs the post-verbal NP and is co-superscripted with it. Recall that such a system would predict nominative Case assignment to direct objects, under the random assignment of superscripting. However, such assignment was blocked by exploiting the generalization that all verbs which assign accusative Case also have a θ -position as their subject (see section 2 above for discussion). However, the reanalyzed particles in Hebrew seem to violate this generalization. Although they have accusative Case assignment features, they do not have a θ -position as their subject. Consequently, precisely in the case of these Hebrew particles, we expect two possible derivations, depending on the superscript assigned to the post-particle NP. If the post-particle NP is assigned the same superscript as the AGR element, we expect nominative Case in the PtP, and we do not expect the particle to function as a proper governor. This derivation is the nominative derivation outlined in detail in section 3 above. If, on the other hand, the superscript assigned to the post-particle NP does not agree with that of AGR, nominative Case cannot be assigned. Consequently, the derivation can only be salvaged if accusative Case is assigned by the particle. If accusative Case is assigned, however, the particle becomes a proper governor and we predict the grammaticality of (49) and (50) above.

In the accusative derivation, the clitic on the particle is reanalyzed as well: it is no longer a composition of the AGR node attached to the particle with gender, number and person features inserted by the rule (39) above. Rather, it is the regular clitic, incorporating the accusative Case features of the particle itself, having the structure in (53):

(53) [_{Pt} Pt, [α gender, β number, δ person, +accusative]

Consequently, we do not expect the sentence in (54) to be grammatical in the accusative derivation (recall that it was ungrammatical in the nominative derivation as well, but due to different reasons. See (44) above and related discussion):

(54) *'eyn-enu_i 'et ha-xatul_i ba-gan
 exist-not acc the-cat in-the-garden
 'the cat is not in the garden'

In (54) the clitic absorbs the accusative Case and hence 'the cat' cannot be assigned Case.¹⁹

Note now that, given these two possible derivations, the non-topicalized reading of (51)a and the sentence in (51)b are still ruled out.

Consider first (51)b. The accusative Case marker 'et is not present, hence we know that the definite direct object sifrey ha-yeladim 'the children's books' is not marked as accusative. However, if the particle does not assign accusative, it cannot function as a proper governor. It follows that the sentence (51)b contains an empty category which is not properly governed in the post-particle position. Of course, that empty category could be properly governed if (39) above applied, resulting in a clitic spell-out. This situation would yield the grammatical (55) corresponding to (36)b above (and see also derivation (47) above):

(55) sifrey ha-yeladim yeš^v-nam_i [e]_i ba-sifriya
 'the children's books are in the library'

Now consider (51)a. There is no overt accusative Case marker on indefinite direct objects (see chapter 2 section 4.2 for discussion of 'et), hence we do not know whether 'children's books' was assigned accusative or not. If no accusative Case was assigned, the non-topicalized reading of (51)a is ruled out in the same way that (51)b is ruled out. Now let us consider the possibility that accusative Case was assigned. In this case, when the NP is moved to the subject position, it moves into a null category that was co-superscripted with AGR in the base (see above for discussion). If the superscript of the moved element conflicts with that of the null category, the conflict will lead to ungrammaticality. If it agrees with that of the null category, the moved NP carries the same superscript as AGR and thus it will be assigned nominative Case. If we assume that accusative Case was assigned to the moved NP prior to its preposing, such assignment will result in a Case conflict and hence in ungrammaticality. If accusative Case was not assigned prior to movement, it will be assigned to the coindexed trace. However, since the antecedent of that trace carries the same superscript as AGR, so does the trace. Thus this assignment will result in the situation in (56):

(56)	NP^j	AGR^j	$[_{PtP} Pt$	$[e]^j]$
	[nominative]			[accusative]

In (56), NP^j forms an A-chain with its co-superscripted trace. This chain is thus assigned two distinct Cases; hence this situation results in Case conflict and in ungrammaticality. Now consider the topicalization reading. In this derivation, the NP is moved to a non-Case position and hence the

trace left behind can be accusative. This fact does not cause any conflict in Case assignment to chains. In fact, as required by the visibility hypothesis (see chapter 2, appendix, for discussion) the trace has to be marked as accusative, since it is a variable. Thus, the topicalized reading is the only possible reading of (51)a.

It has been observed by Shoshani (1980) that the process of reanalyzing post-verbal subjects as direct objects is more general, and applies to other verbal configurations as well. Thus, in substandard Hebrew, (57)c, (58)c and (59)c are grammatical:

- (57)a. hayta ktuva yedi'a xasuva^v ba-'iton
was-f written-f new(s)-f important in-the-paper
'an important piece of news was written in the paper'
- b. ha-yedi'a ha-zot hayta ktuva ba-'iton
the-new(s)-f the-this-f was-f written-f in-the-paper
- c. haya katuv 'et ha-yedi'a ha-zot ba-'iton
was-m written-m acc the-new(s)-f the-this-f in-the-paper
- (58)a. meforatim harbe dvarim ba-karoz ha-ze
specified-m-pl many things-m-pl in-the-leaflet the-this
'many things are specified in this leaflet'
- b. harbe devarim meforati ba-karoz ha-ze
many things-m-pl specified-m-pl in this leaflet
- c. meforat 'et ha-dvarim ba-karoz ha-ze
specified-m-sg acc the-things-m-pl in this leaflet
- (59)a. karta l-i te'una xamura ba-derex
happened-f to-me accident-f serious-f in-the-road
'I had a serious accident on the road'
- b. te'una xamura karta l-i ba-derex
accident-f serious-f happened-f to-me in the road
- c. kara l-i kvar 'et ha-te'una ha-zot kodem
happened-m to-me already acc the-accident-f the-this-f before

The verbs in (57)-(59) are ergative verbs which were reanalyzed to have accusative Case assigning features, in a similar way to the reanalysis which applied to yes^v and 'eyn.²⁰ If the post-verbal NP in these cases is assigned the same superscript as AGR, once AH applies in the syntactic component, the post-verbal NP is assigned nominative. Alternatively, the post-verbal NP can move to the subject position, in which case AH does not apply in the syntax and nominative Case is assigned in the usual way. These cases are demonstrated by sentences (a) and (b) of (57)-(59). When the post-verbal NP is assigned nominative, we expect full agreement between the verbal inflection and the subject, and indeed, we find such full agreement in the (a) and (b) cases. In the (c) cases, on the other hand, the post-verbal NP is assigned a superscript which differs from that of AGR. Hence it is assigned accusative by the verb itself. In these cases we do not expect agreement between the verbal inflection and the accusative NP. Indeed, as shown by the (c) cases above, we find in these cases that the verb is inflected in the 3rd person masc. sing., the unmarked form, regardless of the gender and number of the post-verbal NP.

Note that in (57)c. (58)c and (59)c as well as in (48)-(50) above, we nevertheless have to assume that AH applied in the syntax, so as to permit a (pleonastic) PRO to appear in subject position. If AGR does not move into the VP in the syntactic component, the subject position is governed but not properly governed, thus blocking the occurrence of any empty element, PRO or [e].

Thus the accusative derivation of existential sentences as well as the accusative derivation of some ergative verbs in Modern Hebrew supply interesting evidence for our claim that there is no rule which co-superscripts the inserted PRO in ergative configurations and the post-verbal

subject. Rather, NP's are superscripted at random. If they agree in superscripting with AGR they are assigned nominative. But if they don't, and if there is no other way to assign Case to them (in the case of re-analyzed existentials and ergatives, where accusative Case is assigned), the configuration is ruled out. On the other hand, if the post-verbal NP's (or post-particle NP's) can be assigned accusative by the verb or by the particle, we expect both derivations to be grammatical, and indeed they are.

An interesting confirmation of the assumption that superscripts are assigned at random to post-verbal NP's is found in English. Thus both (60)a and (60)b are grammatical, although the latter is considered substandard English:

- (60)a. there are at least seven people in the garden
 b. there is at least seven people in the garden

The rule suggested in Chomsky (1981) which co-superscripts expletive inserted PRO's with post-verbal subjects in ergative constructions is also utilized to co-superscript the pleonastic element there in (60) with the post-verbal subject. In this case, the co-superscripting is utilized to form an A-chain which consists of the pleonastic element inserted at S-structure and the post-verbal NP. This A-chain is then assigned Case by AGR. Note that since in English AH cannot apply in the syntax, the formation of an A-chain linking the pleonastic element to the post-verbal NP is crucial. In this way, the assignment of nominative Case to the pleonastic element enables the post-be NP to be part of an A-chain with Case. If no A-chain is formed, the post-verbal NP cannot be assigned Case and the derivation would thus be ungrammatical (and see chapter 2

appendix, for some discussion).

Let us assume, however, that be in English is reanalyzed much as the particles in Hebrew are: it can assign accusative Case. (Note, however, that the question of proper government which accompanied the assignment of accusative Case in Hebrew is irrelevant here. Be, being a verbal element, is always a proper governor.) Now let us assume that the superscripting of the post-be NP is random. If the superscript on the post-be NP is identical to that of AGR (and of the pleonastic element there) an A-chain is formed which is assigned nominative Case. In this case, we expect agreement between the post-verbal NP and the inflection on the verb be. This is the sentence given in (60)a, in which such agreement is attested. Now let us suppose that the post-be NP is assigned a superscript different from that of AGR and the pleonastic element there. In this case an A-chain is not formed and the post-be NP cannot be assigned nominative Case. However, it can be assigned accusative Case by be. In this case, we do not expect agreement between the verbal inflection and the post-be NP. (60)b is an example of this derivation. In (60)b, the post-be NP does not agree with the verbal inflection and thus we can assume that the NP is assigned accusative Case.²¹

Let us now conclude our discussion of existential sentences in Modern Hebrew. It has been suggested that rather complicated facts which bring together pro-drop phenomena and proper government by clitics can be accounted for if we assume the essentials of the pro-drop analysis suggested in Chomsky (1981), and the analysis of clitics proposed in this study. We have shown that, in existential sentences in Hebrew, the clitic which serves as a proper governor of an empty category is composed of gender, number and person features attached to the existential particle

along with the AGR node attached to the particle following the application of the rule of Affix Hopping. It was further shown that, by allowing for random superscripting of NP's, we can eliminate a special rule of co-superscripting pleonastic elements and post-verbal NP's, while increasing the explanatory power of the grammar. The random superscripting accounted for the availability of both nominative and accusative derivations in a particular class of cases, namely the class of cases in which a verbal element has accusative Case assignment features, but does not take a θ -position as its subject.

We have further clarified in this chapter the nature of the pro-drop phenomenon as it appears in Modern Hebrew. It was shown that, given a rule which transfers a referential index from the person marker in AGR to the subject position, the distribution of arbitrary and controlled PRO's in Modern Hebrew vs. the distribution of PRO's which have definite reference can be accounted for. Insofar as the phenomena described in this section can be accounted for by using the analysis of pro-drop sketched above and the analysis of clitics promoted in this study, the data provide strong evidence for the validity of these analyses.

FOOTNOTES: CHAPTER 4

1. Interestingly, the clitics attached to 'eyn and to yeš^v (as well as to two other particles which exhibit similar behavior, but which are very archaic: hine -- roughly, 'here', and 'od -- roughly, 'still') are morphologically distinct both from object clitics (which are attached to prepositions and nouns and, in earlier stages of Hebrew, to verbs as well) and from inflectional agreement markers. Thus, the following paradigm holds:

	<u>particle clitic</u>	<u>object clitic</u>	<u>agreement marker (past tense)</u>
1 sg	-eni	-i, -ni	-ti
2 m sg	-nxa	-xa	-ta
2 f sg	-nex	-ex, -ax	-t
3 m sg	-no, -nu	-o	∅
3 f sg	-na	-a	-a
1 pl	-nenu	-enu, -anu	-nu
2 m pl	-nexem	-xem	-tem
2 f pl	-nexen	-xen	-ten
3 m pl	-nam	-am	-u
3 f pl	-nan	-an	-u

The object clitics are sometimes used instead of the particle clitics.

This seems to be rather idiosyncratic. Thus, for the particles 'eyn or 'od the particle clitics can be used, but for yeš^v only the object clitics can be used. See Gesenius (1910) for some discussion of the historical source of the n in the particle clitics.

2. (7)a is possible when the fronted NP is indefinite and when the sentence receives a topicalized reading:

- (1) šloša^v xatulim^v yeš^v ba-gan
'three cats, there are in the garden'

The topicalization of a definite NP would require an accusative object marker preceding the topicalized element:

- 7
- (ii)a. 'et ^vslošet ha-xatulim, yeš^v ba-gan
 acc three the-cats exist in-the-garden
 'the three cats, they are in the garden'
- b. *^vslošet ha-xatulim, yeš^v ba-gan
 three the-cats

As will be shown below, existential sentences have an accusative derivation which has somewhat different properties. (i) and (ii) are part of this derivation, as is clear from the availability of an accusative object marker preceding a definite fronted NP. The accusative derivation is irrelevant to the discussion in this section.

3. The use of 'eyn as a negation marker in the present tense originates in earlier stages of Hebrew, in which all present tense sentences were in fact nominal sentences with no tense value. In that earlier system the verbal inflection indicated aspect rather than tense, which was expressed by various affixes and particles. In Modern Hebrew the aspect distinction has been reanalyzed as a tense system, and the active participial form -- as a present tense inflection. Thus, in fact, 'eyn is quite inappropriate as a negation marker of present tense sentences in Modern Hebrew, since they are no longer nominal. Interestingly, native speakers of Modern Hebrew will find negation with 'eyn rather stilted, and will avoid using it as much as possible (in spite of the desperate attempts of the Hebrew Academy of Language to restore this usage). Rather, they will use lo, the negation marker for tensed verbs. Nevertheless, intuitions about the grammaticality of (12)a-b, compared, say, with (i), are very sharp:

- (i) *'eyn-ena hi yoda'at 'et ha-tšuva^v
 neg-her she knows acc the-answer
 'she doesn't know the answer'

4. In Chomsky (1981), the pro-drop parameter is in fact stated as in (1):

(1) R (= AH) may apply in the syntax.

(1) is part of the grammar of pro-drop languages, but not part of the grammar of non-pro-drop languages. However, following our assumption that local rules are free to apply in any component of the grammar unless specifically restricted from so applying, we find the statement in (20) more adequate. Note that (1) and (20) differ with respect to the tacit assumptions which they incorporate with respect to markedness. Thus, (1) implies that the grammar of pro-drop languages is more marked, since in these languages the application of AH has to be relaxed in order to incorporate (1). On the other hand, (20) implies that non-pro-drop languages are more marked, since in these languages the application of AH has to be restricted by (20).

It is not easy to choose between (20) and (1) on the basis of the evidence available to the language learner with respect to fixing the parameter. The advocates of (1) would argue that the learner of a pro-drop grammar is immediately exposed to subject-less sentences, thus enabling him to determine that (1) is true, whereas the learner of a non-pro-drop language would need negative evidence to determine that his grammar does not contain (1). On the other hand, advocates of (20) may argue that the language learner realizes that (20) is part of his grammar when he first hears a pleonastic it, as in, for instance, it's cold. Furthermore, he may deduce the presence of (20) in his language from the availability of indirect negative evidence: the absence of

pro-drop in extremely simple and immediately accessible sentences. We thus conclude that learnability factors cannot determine the choice between (20) and (i). However, given the restricted class of parameters argued for in this study, we prefer (20) to (i) on theoretical grounds.

5. One could argue that since Case assignment rules can apply at any level, the movement of AGR to the VP in the syntactic component in (21)b should not be relevant: the subject I could be marked nominative in the base. There is, however, an important reason to assume that nominative Case assignment cannot apply in the base. As will be shown below, nominative Case assignment is not dependent only on government by AGR. It is crucially dependent on co-superscripting between AGR and the subject position. The mechanism which checks the appropriateness of co-superscripting is located at S-structure and only at S-structure (as are the binding conditions, which are similar in nature; see chapter 2, appendix, for discussion). It follows that nominative Case assignment cannot apply before or after S-structure. It will be noted in section 3 below that nominative Case assignment cannot be seen as a transference of a feature from the AGR node to the subject. In this sense, it does not fall within our description of Case assignment rules in chapter 1, section 2 above.

6. Ergative sentences are, in essence, configurations in which the subject is base-generated post-verbally and may either be fronted into the regular subject position or stay in its post-verbal position. Such an analysis for the choice of auxiliaries in Italian was argued for by Perlmutter (1978) (the "unaccusative hypothesis") and consequently by Napoli (1973) and others. See Borer (1980a) for an argument that such construc-

tions exist in Modern Hebrew, and that, in fact, all the morphologically passive verbs are of this sort.

Note that we are assuming that (23)a is ergative. There have, however, been other analyses proposed for the il construction in French. For discussion, see Kayne (1975), Pollock (1979) and references therein.

7. (24)c is, in fact, somewhat marginal. I believe, however, that it is not mere scrambling. Rather, it is an adjunction to VP. This assumption is verified by the fact that the insertion of a sentence adverb between 'the apples' and 'three men' will result in an even greater marginality:

(1) ??'axlu 'et ha-tapuxim 'etmol ba-cohorayim Rachel ve-Dan
 ate acc the-apples yesterday in-noon Rachel and-Dan
 'Rachel and Dan ate the apples yesterday at noon.'

8. Interestingly, (30)a is redundantly ungrammatical, since the [e] in subject position is governed (hence it is not PRO), but not properly governed (hence it violates the ECP). Given the contextual definition of empty elements (Chomsky, 1981; see chapter 2, appendix, for discussion), only PRO can appear in the subject position of (30), because the empty element in the subject position does not have an antecedent with the same θ -role, and hence cannot be anaphoric [e]. It follows immediately that this position cannot be governed at S-structure, since a governed PRO is excluded by the binding conditions.

9. And see also references in footnote 6 above.

10. An obvious exception to this generalization is the case of exceptional Case assignment. In this case, the verb assigns accusative Case,

but it does not assign a θ -role. This situation is illustrated in (i):

(i) John believes Bill to have won the race.

In (i), believe assigns accusative Case to Bill, but it does not assign a θ -role to it. However, in this case Bill is crucially assigned a θ -role by the VP of the subordinate clause: it is assigned a θ -role as the subject of win. Thus in this case as well, there are two referential expressions for every occurrence of believe, when believe assigns accusative Case.

11. Following the θ -criterion as interpreted by the projection principle (see chapter 1 for discussion) PRO in the subject position of "regular" pro-drop configurations has to be base-generated, since it occupies a θ -position. However, in the ergative cases or in the pleonastic cases, such a PRO is inserted later into a base-generated null category, and thus it cannot receive a referential index from AGR. I am indebted to N. Chomsky for pointing out to me the relevance of this distinction for the transmission of referential indices. For a similar proposal for capturing the availability of referential pro-drop in some cases vs. its absence in others, see Rizzi (1980). Rizzi, however, argues that the empty element in subject position is [e] rather than PRO.

12. The grammaticality of (34)a-b cannot be derived from some relaxation of the restriction on pro-drop in embedded clauses. Without a controller, pro-drop in embedded clauses is ungrammatical:

- (i) *Rina_i biksa^V se^V PRO_i yavo
 'Rina (fem) asked that he will come'

Interestingly, however, the controller in tensed clauses can be determined by the discourse, and is not restricted to the sentence (unlike control in infinitivals, which is strictly limited to the sentence). Thus, the sentence in (i) is grammatical if a possible controller was mentioned earlier in the discourse.

Pro-drop in the 3rd person (although never in the present tense) is also used as a literary device, in particular with the literary style known as "free indirect style". In these cases, however, there is no distinction between embedded or non-embedded contexts: pro-drop can apply in matrix sentences as well. For some discussion of pro-drop in free indirect style see Borer (in press).

13. Clearly there are additional conditions which determine the distribution of PRO's when no referential index is assigned by AGR. Thus, in the controlled cases, present tense nevertheless cannot appear. Compare (i) with (34)b:

- (i; *Dan 'amar le-Talila_i se^V PRO_i tamid me'axeret
 Dan said to-Talila_i that always late
 'Dan said to Talila that she is always late'

On the other hand, in the arbitrary control cases only the masculine plural form of the 3rd person verb can appear. Compare (ii) to (35)a:

- (ii) *'amar 'et ze ba-radio 'etmol
 said (sg) acc this in-the-radio yesterday

We thus conclude that arbitrary PRO in Hebrew is plural masculine, as it

is in Italian. Interestingly, in Russian, arbitrary PRO shows plural number when animate, but singular number when it is inanimate. (I am indebted to M. Halle for pointing this out to me.)

Note that the existence of additional conditions on the appearance of PRO, whose nature is as yet unclear, does not invalidate our proposal. For our purposes, it is crucial to show that PRO can appear in environments where it is assigned a referential index, not by AGR, but by a controller, or arbitrarily, without being coindexed with the person marker of AGR. This fact has been established regardless of the existence of further restrictions.

14. Our analysis predicts that, corresponding to the ungrammatical (38)b, we should have grammatical sentences in which PRO in subject position is either controlled or in which the clitic is 3rd person plural masculine and can receive arbitrary interpretation. The first prediction is borne out, as is illustrated by the grammaticality of (i):

- (i) Asaf ma'amin ^vse-'eyn-enu₁ muxsar^v
 Asaf believes that-neg-him talented
 'Asaf believes that he is not talented'

With respect to the second prediction, note that it is bizarre, in semantic terms, to assert or negate the existence of an arbitrarily chosen referent in existential sentences. Thus (ii) is very strange under an arbitrary reference reading:

- (ii) ^vyes-nam ba-gan
 exist-they in-the-garden

Thus, I believe that, although arbitrary reference is impossible in cases such as (38)b, it is due to independent factors.

15. Note that we are assuming that the clitic in (39) is visible in LF, although it does not have a Case feature. Although we accept the visibility hypothesis, requiring that NP's have Case if they are to be visible for θ -role assignment in LF (but see appendix to chapter 2) this is irrelevant for (39), since we assume that clitics are not in argument positions. Hence they do not participate in the binding conditions and cannot be contained in an A-chain. Instead, they are features on the head of their phrase. As such, they are visible in LF because the head of which they are part is visible.

16. The empty-bracket notation -- [_{NP}] -- indicates a null category which is generated in the base and is filled in the course of the derivation either by a moved element or by a pleonastic element or expletive PRO inserted at S-structure. This null category differs from [_{NP}^e] in that it does not contain ϕ -features. In drawing this distinction we follow Chomsky (1981).

17. Reanalysis in non-existential usages of the particles yes^V and 'eyn is triggered, I believe, by the incompatibility of existential meaning and definite post-verbal subjects. Once the post-particle NP has been reanalyzed as a direct object rather than a subject, none of the semantic restrictions on existential sentences hold, and post-particle NP's can be definite. Due to this fact, existential sentences are still derived using the nominative derivation outlined above. On the other hand, when

the existential particles are used to express possession or location, the accusative derivation is preferred. (48)-(50) in the text have locative readings. (i) below has a possessive reading:

- (i) ^V
 yeš l-i 'et ha-sefer ha-ze
 exist to-me acc the-book the-this
 'I have this book'

It will be shown below that when certain ergative verbs are reanalyzed as accusative assigners, the definiteness restriction which usually holds for subjects of ergatives in Hebrew is lifted and the reanalyzed direct object is free to be definite. (For some discussion of the definiteness restriction with respect to ergative verbs, see Borer, 1980a.)

18. The fact that the particles yeš^V and 'eyn acquire verbal nature with respect to proper government once they assign accusative Case surely provides some interesting insight into the nature of proper government. The implications of this correlation, however, will not be explored in this study.

19. Recall that 'et, although it can function as a "rescuing device" for Case-assignment purposes, does not allow for doubling. See chapter 2, section 4.2 and footnote 26 for some discussion.

20. The constructions in (57)-(58) are, in fact, passive constructions. (57) is an adjectival passive construction using the verb haya 'to be', whereas (58) shows the morphological passive form pu'al. Both these constructions have active counterparts, as demonstrated by (i)-(ii):

- (i) Dan katav 'et ha-yedi'a ha-zot ba-'iton
 Dan wrote acc the-new the-this in-the-paper
 'Dan wrote this piece of news in the paper'

- (ii) Dan peret 'et ha-dvarim ba-karoz
 Dan specified acc the-things in-the-leaflet
 'Dan specified the things in the leaflet'

We believe, however, that all passive constructions in Hebrew belong to the class of ergative verbs, in that, like other ergative verbs, their subject originates in the VP, where it can be assigned nominative if AH applies in the syntax. If not, it has to move to the regular subject position, where Case assignment is possible. In fact, following our assumptions, the only difference between passive constructions in Hebrew and those in a language like English is that in English AH cannot apply in the syntax. It follows that in English passive constructions the post-verbal subject cannot receive Case. Consequently, the post-verbal subject has to be fronted to the subject position to receive Case. In Hebrew, on the other hand, AH can apply in the syntax, and consequently the fronting of the post-verbal subject is optional. For some more discussion of this point see Borer (1980a).

21. The French impersonal construction, with expletive il, shows a phenomenon similar to the Hebrew (c) examples in (57)-(59) and to English sentences like (60)b. French impersonal sentences uniformly show a lack of overt agreement:

- (1)a. il est arrivé sept hommes
 expl. is arrived seven men
 (sing)
- b. *il sont arrivé(s) sept hommes
 (plur)

Modern French has preserved surface Case marking only in definite clitics.

The definiteness restriction thus prevents us from checking the Case marking on the post-verbal NP. Haik (1981) has argued that Case here is assigned by the verb, and not by agreement, suggesting that the Case-marking is accusative. Wehrli (personal communication) has noted that in earlier stages of French, before the loss of most surface Case distinctions, such post-verbal NP's are, in fact, often marked accusative, thus confirming our hypothesis of random superscripting.

CONCLUSION

The research whose output is presented in the previous chapters revolves around two major axes. First, we presented a restricted class of parameters. Second, we proposed a particular theory of clitic configurations, within which a substantial amount of parametric variation can be accounted for by assuming the restricted class of parameters proposed above.

We have suggested in this study that parametric variation in clitic constructions can be explained if we assume that all these variations are dependent on morphological properties of local rules -- on properties of their application and on properties of the local rules themselves. The algebra of local rules we have taken to be determined by UG as well as by the particular ways in which the application of local rules can be parametrized. Thus, local rules can apply at any level at which the environment for their application is met. However, their application can be restricted as a language-particular option. Thus, whereas both principles (1) and (2) are part of the universal properties of local rules, the decision to restrict the application of a particular local rule R in a particular grammar G to a particular level L is part of the core grammar of an individual language. Such a restriction is universally formulated as (3):

- (1) Given a local rule R, R may apply at any level.
- (2) The application of R may be restricted to particular levels.
- (3) R in G may not apply at L.

Many local rules were directly argued for in this study: local rules of Case assignment, local rules of Case spell-out, local rules of dummy Case-marker insertion and local rules of Case climbing. For each of these rules it was shown how the environment of the rule may be created at different levels, how the application of the rule determines the variation between languages, and how, in some cases, restrictions on the level at which a local rule applies result in substantial inter-language variation. Insofar as the phenomena discussed in this study can be accounted for by employing the local rules postulated above, and insofar as the particular properties which we assumed local rules to have can account for parametric variation, the phenomena discussed in this study supply strong evidence for the system we have proposed. .

The theory of clitics which we offered in this study crucially involves notions such as government and Case. As such, our theory is firmly embedded in the Government-Binding framework and supplies additional evidence for its leading ideas. We argued in this study that clitics are best characterized as the insertion of gender, number and person features into the matrix of a Case-assigning element. These features, when combined with the Case feature, are given an independent phonological representation which, in turn, "absorbs" the Case feature. Consequently, this Case feature can no longer be assigned to a complement. Rather, an independent Case assigner is required to render a phonologically realized complement grammatical. We differed from earlier base-generation accounts of clitic configurations in several respects: first we showed that the clitic is a genuine feature on the head of its phrase.

Second, we showed that when no complement appears apart from the clitic itself, the complement node is nevertheless base-generated by the regular base rules and dominates an empty element which is not PRO. We demonstrated that our analysis is, in fact, correct by exploring the government properties of clitics and the conditions under which coindexing between clitics and governed complements is possible. The theory of clitics which we proposed was shown to account for facts in a wide range of languages: Hebrew, Rumanian, Spanish and French. (For an account of clitics in Yoruba which is compatible with our analysis, see Pulleyblank, 1980. For an account of clitics in Standard Arabic along the lines suggested in this study, see Borer, 1980b. For an account of clitics in Lebanese Arabic, see Aoun, forthcoming.)

In these last remarks, we would like to offer some speculations on the class of possible parameters.

As we noted in the introduction to this work, there is no a priori reason for excluding parametrization over every aspect of UG. The question of which aspects of UG are subject to parametrization and which are not is entirely an empirical issue. Furthermore, one could argue for a system in which every aspect of UG can be parametrized over and, consequently, for a system that would allow for the existence of two grammars which have absolutely nothing in common. One could imagine, within such a system, a grammar that will have no major categories and which will not utilize distinctive features. If such a grammar can be found, then clearly it will supply evidence for the possibility of parametrization over every aspect of UG. It is our opinion, however,

that advocating a system which allows for such variation greatly weakens the claim for language universals. Rather, it is desirable, in our opinion, to try to restrict the class of possible parameters.

A plausible theory of parameters will, most likely, associate particular parameters with every component of the grammar. These parameters will be directly linked to the properties of the component in question. Thus, the \bar{X} -system will have parameters which are connected to the ordering of elements and, perhaps, to the number of bars. The transformational component will have parameters that will specify the value of α , and, perhaps, some parameters that will relate to conditions on the application of "Move α ", such as subjacency. The phonological component will include parameters which will select various systems of distinctive features, etc. Within such a model, we take the class of parameters defined in this study to be that class of parameters associated with inflectional morphology.

Little work has been done on defining the class of possible parameters linked with other components of the grammar. The study of parameters is still in its beginning. Some interesting contributions, however, have been made by Kean (1975), who studied the structure of possible phonological systems, and by Rizzi (1979), who studied the effects of parametric variation in the choice of bounding nodes for subjacency (see in this respect also Sportiche, 1979, and Jaeggli, 1980, who apply Rizzi's proposal to French and Spanish, respectively). We hope that our research constitutes yet another step on the road towards a restrictive theory of parameters.

REFERENCES

- Aissen, J. (1974) The Syntax of Causative Constructions, unpublished dissertation, Harvard University, Cambridge, Mass.
- Aoun, Y. (1978) "Structure interne du groupe nominal en arabe," in Analyses et théorie 1, Université de Paris VIII.
- (1979a) "A Short Note on Cliticization," unpublished paper, MIT, Cambridge, Mass.
- (1979b) "On Government, Case marking, and Clitic Placement," Generals paper, MIT, Cambridge, Mass.
- (1981) "ECP, Move α , and Subjacency," to appear in Linguistic Inquiry vol. 12.
- (forthcoming) MIT dissertation.
- Aoun, Y., N. Hornstein and D. Sportiche (1981) "Some Aspects of Wide Scope Quantification," Journal of Linguistic Research, Vol. 1 No. 3, pp. 69-95.
- Aoun, Y. and D. Sportiche (1981a) "On the Formal Theory of Government," paper presented at 1981 GLOW colloquium, Göttingen, Germany.
- Aoun, Y. and D. Sportiche (1981b) "The Domain of Weak Cross-Over Restrictions," in H. Borer and Y. Aoun (eds.).
- Aoun, Y., J.R. Vergnaud and M.L. Zubizarreta (forthcoming) "On Deriving the ECP from the Binding Conditions," MIT, Cambridge, Mass.
- Berman, R.A. (1978) Modern Hebrew Structure, University Publishing Projects, Tel Aviv, Israel
- Bordelois, I.A. (1974) The Grammar of Spanish Causative Complements, unpublished dissertation, MIT, Cambridge, Mass.
- Borer, H. (1979) "Restrictive Relatives in Modern Hebrew," Generals paper, MIT, Cambridge, Mass.
- (1980a) "Empty Subjects in Modern Hebrew and Constraints on Thematic Relations," in Proceedings from the 10th Annual Meeting of the North Eastern Linguistic Society, Ottawa, Canada.
- (1980b) "On Extraction from Clitic-Doubled Constructions," paper presented in the 11th annual meeting of the North Eastern Linguistic Society, Cornell University, Ithaca, New York.

- (1981) "On the Definition of Variables," in Journal of Linguistic Research, Vol. 1, No. 3, pp. 16-40.
- Borer, H. and Y. Aoun (eds.) (1981), Theoretical Issues in the Grammar of Semitic Languages: MIT Working Papers in Linguistics Vol. III MIT, Cambridge, Mass.
- Bresnan, J. (1976) "On the Form and Function of Transformations," in Linguistic Inquiry, Vol. 7, pp. 3-40.
- Bresnan, J. and J. Grimshaw (1978) "The Syntax of Free Relatives in English," in Linguistic Inquiry, Vol. 9, pp. 331-392.
- Burzio, L. (1981) Intransitive Verbs and Italian Auxiliaries, unpublished dissertation, MIT, Cambridge, Mass.
- Chomsky, N. (1957) Syntactic Structures, Mouton, The Hague.
- (1965) Aspects of the Theory of Syntax, MIT Press, Cambridge, Mass.
- (1970) "Remarks on Nominalization," in Studies on Semantics in Generative Grammar, Mouton, the Hague.
- (1973) "Conditions on Transformations," in S. Anderson and P. Kiparsky (eds.) A Festschrift for Morris Halle, Holt, Rinehart, and Winston, New York.
- (1975) Reflections on Language, Pantheon, New York.
- (1976) "Conditions on Rules of Grammar," in Linguistic Analysis Vol. 2, pp. 303-351.
- (1977) "On WH Movement," in P.W. Culicover, T. Wasow and A. Akmajian (eds.).
- (1980) "On Binding," in Linguistic Inquiry, Vol. 11, pp. 1-46.
- (the Pisa Lectures), original manuscript of lectures given in the 1979 GLOW colloquium, Pisa, Italy (prepared by J.Y. Pollock and H.G. Obenauer).
- (1981) Lectures on Government and Binding, Foris Publications, Dordrecht.
- Chomsky, N. and H. Lasnik (1977) "Filters and Control," in Linguistic Inquiry, Vol. 8, pp. 425-504.
- Culicover, P.W., T. Wasow and A. Akmajian (eds.) (1977) Formal Syntax, Academic Press, New York.

Doron, E. (1980) "On the Semantic Role of Resumptive Pronouns," paper presented at the LSA Winter Meeting, San Antonio, Texas.

Dresher, E. (1973) "The Syntax of the Hebrew Constructive," unpublished paper, University of Massachusetts, Amherst, Mass.

Emonds, J. (1970) Root and Structure-Preserving Transformations, unpublished dissertation, MIT, Cambridge, Mass.

----- (1976) A Transformational Approach to English Syntax: Root, Structure-Preserving and Local Transformations, Academic Press, New York.

----- (1980) "Generalized NP- α Inversion: Hallmark of English," unpublished paper, University of Washington, Seattle, Wash.

Fassi Fehri (1980) "Some Complement Phenomena in Arabic, Lexical Grammar, the Complementizer Phrase Hypothesis and the Non-Accessibility Condition," unpublished paper, University of Rabat, Rabat, Morocco.

Freidin, R. (1978) "Cyclicity and the Theory of Grammar," Linguistic Inquiry, Vol. 9, pp. 519-549.

Freidin, R. and H. Lasnik (1981) "Disjoint Reference and WH Trace," in Linguistic Inquiry, Vol. 12, pp. 39-54.

① Gesenius, W., E. Kautzsch and A.E. Cowley (1910) Gesenius' Hebrew Grammar, Clarendon Press, Oxford.

Grimshaw, J. (1977) English WH Constructions and the Theory of Grammar, unpublished dissertation, University of Massachusetts, Amherst, Mass.

Groos, A. and H. van Riemsdijk (1979), "Matching Effects in Free Relatives," paper presented in the 1979 GLOW colloquium, Pisa, Italy.

Haïk, I. (1981) "On Clitic en in French," to appear in Journal of Linguistic Research.

Hale, K. (1978) "The Structure of English Sentences," unpublished paper, MIT, Cambridge, Mass.

Hayon, Y. (1973) Relativization in Hebrew, Mouton, The Hague.

Huang C.-T. J. (1980) "Move WH in a Language without WH-Movement," Generals paper, MIT, Cambridge, Mass.

Hurtado, A. (1980) "Le contrôle par des clitiques," unpublished paper, Simon Fraser University, Burnaby, British Columbia, Canada.

Jackendoff, R. (1972) Semantic Interpretation in Generative Grammar, MIT Press, Cambridge, Mass.

- (1977) X̄-Syntax: A Study of Phrase Structure, Linguistic Inquiry Monograph 2, MIT, Cambridge, Mass.
- Jaeggli, O. (1980) On Some Phonologically-Null Elements in Syntax, unpublished dissertation, MIT, Cambridge, Mass.
- Jake, J. (1980) "Object Verb Agreement in Tigre," in Studies in the Linguistic Sciences, University of Illinois, Urbana, Illinois.
- Kayne, R.S. (1969) The Transformational Cycle in French Syntax, unpublished dissertation, MIT, Cambridge, Mass.
- (1975) French Syntax: The Transformational Cycle, MIT Press, Cambridge, Mass.
- (1980a) "Extensions of Binding and Case Marking," Linguistic Inquiry, Vol. 11, pp. 75-96.
- (1980b) "On Certain Differences between French and English," to appear in Linguistic Inquiry Vol. 12, No. 3.
- (1981) "ECP Extensions," in Linguistic Inquiry, Vol. 12, pp. 93-134.
- Kean, M.-L. (1975) The Theory of Markedness in Generative Grammar, unpublished dissertation, MIT, Cambridge, Mass.
- Manzini, M.-R. (1981) "Some Italian for Linguists," to appear in A. Marantz and T. Stowell (eds.).
- Marantz, A. and T. Stowell (forthcoming) MIT Working Papers in Linguistics Vol. IV.
- May, R. (1977) The Grammar of Quantification, unpublished dissertation, MIT Cambridge, Mass.
- McCarthy, J. (1979) Formal Problems in Semitic Phonology and Morphology, unpublished dissertation, MIT, Cambridge, Mass.
- Milsark, G. (1974) Existential Sentences in English, unpublished dissertation, MIT, Cambridge, Mass.
- Montalbetti, M. (1981) "Consistency and Clitics," unpublished paper, MIT, Cambridge, Mass.
- Napoli, D.-J. (1973) The Two si's of Italian, unpublished dissertation, Harvard University, Cambridge, Mass.
- Perlmutter, D. (1972) "Evidence for Shadow Pronouns in French Relativization," in The Chicago Which Hunt: Papers from the Relative Clause Festival, Chicago Linguistic Society, University of Illinois, Chicago, Illinois.

- Perlmutter, D. (1978) "Impersonal Passives and the Unaccusative Hypothesis," in Proceedings of the Forth Annual Meeting of the Berkeley Linguistic Society, UCLA, Los Angeles, California.
- Pesetsky, D. (1978) "Complementizer-Trace Phenomena and the Nominative Island Condition," to appear in Linguistic Review.
- Pollock, J.-Y. (1979) "Réanalysé et constructions impersonnelles," in Recherches Linguistique Vol. 8, pp. 72-130.
- Prince, A. (1975) The Phonology and Morphology of Tiberian Hebrew, unpublished dissertation, MIT, Cambridge, Mass.
- Pulleyblank, D. (1980), "Clitics and Extraction in Yoruba," General Paper, MIT, Cambridge, Mass.
- Quicoli, C. (1976) "Clitic Movement in French Causatives," appeared in Linguistic Analysis, Vol. 6 No. 2, May 1980.
- Reinhart, T. (1976) The Syntactic Domain of Anaphora, unpublished dissertation, MIT, Cambridge, Mass.
- (1979) "A Second COMP Position," paper presented in the 1979 GLOW colloquium, Pisa, Italy.
- Reuland, E. (1981), "Domains of Governors vs. Boundaries for Government," paper presented in the 1981 GLOW colloquium, Göttingen, Germany.
- Rivas, A. (1977), A Theory of Clitics, unpublished dissertation, MIT, Cambridge, Mass.
- Rizzi, L. (1978) "A Restructuring Rule in Italian Syntax," in S.J. Keyser (ed.) Recent Transformational Studies in European Languages, Linguistic Inquiry Monograph No. 3.
- (1979) "Violations of the WH Island Constraint in Italian and the Subjacency Condition," in Montreal Working Papers in Linguistics Vol. 11.
- (1980) "WH Movement, Negation and the Pro-Drop Parameter," unpublished paper, Scuola Normale Superiore, Pisa.
- Ross, J.R. (1967) Constraints on Variables in Syntax, unpublished dissertation, MIT, Cambridge, Mass.
- Rouveret, A. and J.-R. Vergnaud (1980) "Specifying Reference to the Subject: French Causatives and Conditions on Representations," Linguistic Inquiry, Vol. 11, pp. 97-202.
- Ruwet, N. (1972) Théorie syntaxique et syntaxe du français, Editions du Seuil, Paris.

- Safir, K. (1981) "The ECP, the θ -Criterion, and the Status of Null Expletive Elements," unpublished paper, MIT, Cambridge, Mass.
- Shoshani, R. (1980) "The Object Marker in Hebrew in Intransitive Constructions," unpublished paper, University of Tel-Aviv, Tel-Aviv.
- Sportiche, D. (1979) "On Bounding Nodes in French," to appear in Linguistic Review.
- Steriade, D. (1980) "Clitic Doubling in the Romanian WH Constructions and the Analysis of Topicalization," paper presented in the annual meeting of the Chicago Linguistics Society, Chicago, 1980.
- Stowell, T. (1978) "What was There before There was There?" in Farkas et. al Proceedings from the 14th Annual Meeting of the Chicago Linguistic Society, Chicago, Illinois.
- (1980) "COMP and the ECP," paper presented in the 11th annual meeting of the North Eastern Linguistic Society, Cornell University, Ithaca, New York.
- (1981) ^{Origins of Phrase Structure} ~~Phrase Structure from the Lexicon~~, unpublished dissertation, MIT, Cambridge, Mass.
- Strozer, J. (1976) Clitics in Spanish, unpublished dissertation, UCLA, Los Angeles, California.
- Taraldsen, K.T. (1978) "On the NIC, Vacuous Application, and the That-Trace Filter," University of Indiana Linguistic Club, 1980.
- Vergnaud, J.-R. (1974) French Relative Clauses, unpublished dissertation, MIT, Cambridge, Mass.
- Wehrli, E. (forthcoming) "French Clitics and Causatives," MIT, Cambridge, Mass.
- Williams, E. (1981) "On the Notion "Lexically Related" and "Head of a Word," in Linguistic Inquiry, Vol. 12, pp. 245-274.
- Zubizarreta, M.-L. (1979a) "Pour une restructuration thématique I," in Recherches Linguistiques, Université de Paris VIII.
- Zubizarreta, M.-L. (1979b) "Restructuration thématique II," unpublished paper, MIT, Cambridge, Mass.

BIOGRAPHICAL NOTE

The author was born in Hadera, Israel, on February 19, 1952. She was raised in Petax-Tiqva and in Jerusalem, Israel. She attended the Secondary School of the Hebrew University in Jerusalem. In October 1971 she began attending courses in the University of Tel-Aviv, which she left in June 1972 to travel to Europe. In October 1974 she returned to the University of Tel-Aviv graduating in December 1977, with B.A. in Poetics and Comparative Literature. During the years 1974-1977 she worked as a literary translator and a copy editor for Keter Publishing House in Jerusalem, Israel and for the Jewish Agency organ be-tfuzot ha-gola. She has accepted a post-doctoral fellowship at the School of Social Sciences, University of California, Irvine for the academic year 1981-82. Her publications include:

- (1) "On the Linguistic Aspects of Combined Discourse" (in Hebrew) to appear in Ha-Sifrut ('literature'), Spring 1981, the Porter Institute for Poetics and Semiotics, Tel-Aviv University, Tel-Aviv, Israel.
- (2) "Schwa in Tiberian Hebrew: an Argument for Cyclic Rules of Syllable Structure Modification" in K. Safir (ed) MIT Working Papers in Linguistics Vol 1, 1979, Department of Linguistics, MIT, Cambridge.
- (3) "Empty Subjects in Modern Hebrew and Constraints on Thematic Relations", in Proceedings from the X Annual Meeting of the North-Eastern Linguistics Society, Ottawa, 1979.
- (4) "On the Definition of Variables", to appear in Linguistic Research, University of Indiana Linguistic Club, Bloomington.
- (5) "Extraction from the Clitic-Doubled Constructions", paper to appear in Proceedings from the XI Annual Meeting of the North-Eastern Linguistics Society, Cornell University, Ithaca 1980.
- (6) MIT Working Papers in Linguistics Vol 3: Theoretical Issues in the Syntax, Semantics and Phonology of Semitic Languages (editor, with Joseph Aoun), to appear Summer 1981, Department of Linguistics, MIT, Cambridge.