

HEURISTIC RULES FOR HIGHWAY DESIGN AND MANAGEMENT

by

BRUCE EDWARD VAN EVERY  
Dip.C.E., Ballarat School of Mines  
(1970)  
B.E., Melbourne University  
(1971)

Submitted in partial fulfillment  
of the requirements for the degree of  
Master of Science in Civil Engineering

at the

Massachusetts Institute of Technology  
(August, 1976)

Signature of Author.....  
Department of Civil Engineering, (August 8, 1976)

Certified by.....  
Thesis Supervisor

Accepted by.....  
Chairman, Departmental Committee on Graduate Students  
of the Department of Civil Engineering

ABSTRACT

## HEURISTIC RULES FOR HIGHWAY DESIGN AND MANAGEMENT

by

BRUCE EDWARD VAN EVERY

Submitted to the Department of Civil Engineering on (August 8, 1976) in partial fulfillment of the requirements for the degree of Master of Science in Civil Engineering.

The objective of highway authorities is to provide the least cost means of transportation within the highway network of their jurisdiction. This is only achieved when a delicate balance is struck between construction, user, and maintenance costs.

Highway design and management is a complex field and the interactions amongst the many variables makes the finding of the optimal balance difficult. The advent of the computer has aided the engineer by rapid computation of many feasible solutions allowing the optimal to be found by enumeration. However the problem still remains that there are so many variables and their ranges are so large that exhaustive enumeration can lead to excessive computer costs. Thus it is desirable to limit the range of the search, by applying rules, before resorting to the computer.

Heuristic rules have been in vogue in highway design since its inception. Pavement design especially is one aspect which has been based upon what has been learned from past experience and so the use of heuristic rules is not new to this field.

The heuristic base of highway design and management is expanded in this thesis by the generation of many hypothetical case studies using the Highway Cost Model framework. The results of these case studies were analyzed and these form the basis of the heuristic rules proposed to limit the search for optimality.

In some cases data required for evaluation of prefeasibility studies is not readily available and a heuristic method based on terrain evaluation is suggested to cope with this problem.

The results from this study are no substitute for the knowledge of an experienced highway engineer who is familiar with local conditions, but they serve as a base for those with lesser experience to build upon.

Supervisor:

Fred Moavenzadeh

Title:

Professor of Civil Engineering

## ACKNOWLEDGEMENTS

The author would like to express his thanks to the World Bank for their support of this research and the Country Road Board of Victoria, Australia for their investment in the betterment of their professional staff.

Also the author wishes to thank his thesis advisor, Professor Fred Moavenzadeh, for this advice, guidance and supervision throughout the course of this research and in the preparation of this thesis.

Further thanks go to my colleagues, Fred Berger, Brian Bradmeyer, Yossi Sheffi and Bob Wyatt for their advice and assistance during the course of this research.

Finally a note of recognition is due to the typist, Laurie Tenzer for her contribution in typing this manuscript.

3.

TABLE OF CONTENTS.

	Page
Title Page	1
Abstract	2
Acknowledgement	3
Table of Contents	7
List of Figures	8
List of Tables	
CHAPTER 1 INTRODUCTION.	
1.1 The Overall Budget for Transportation	10
1.2 Project Analysis	11
1.3 Heuristics	13
1.4 Objectives of Thesis	13
1.5 Brief Outline	14
CHAPTER 2 GENERAL FRAMEWORK	
2.1 General Framework	17
2.1.1 Transportation Costs	17
2.1.2 Construction Costs	18
2.1.3 Maintenance Costs	21
2.1.4 Vehicle Operating Costs	23
2.2 Analytic Framework	25
2.3 Data Sources	28
CHAPTER 3 DESIGN APPLICATIONS	
3.1 Overview	29
3.2 General Design Rules	30
3.2.1 Introduction	30
3.2.2 General Rules of Route Location	31

## TABLE OF CONTENTS (Continued)

	Page
3.2.3 Detailed Design Rules	33
3.2.4 Aesthetics	35
3.2.5 General Points	37
3.3 Shortcomings in the Highway Cost Model Averaging Approach	38
3.3.1 Rise and Fall	38
3.3.2 Curvature	44
3.3.3 Conclusions	47
3.4 Location and Route Choice	48
A. Tradeoff between Extra Earthworks and Lesser Grades.	48
3.4.1a Introduction	48
3.4.2a Methodology	48
3.4.3a Conclusions	51
B. Tradeoff between Extra Earthworks and Longer Route.	57
3.4.1b Introduction	57
3.4.2b Discussion	57
3.4.3b Conclusions	58
3.5 Crucial Parameters	59
3.5.1 Geometric Parameters	59
3.5.2 Pavement Design	60
3.5.3 Interest Rate	62
3.6 Staging	62
3.6.1 Introduction	62
3.6.2 Width	63

cont..	5.
3.6.3 Vertical Alignment	64
3.6.4 Horizontal Alignment	65
3.6.5 Surface Type	66
3.6.6 Pavement Thickness	69
3.6.7 Conclusions	69
3.7 Terrain Classification	70
3.7.1 Introduction	70
3.7.2 Research Aims	71
3.7.3 Methodology	72
3.7.4 Terrain Classification	72
3.7.5 Road Parameters	74
3.7.6 Design Standards	74
3.7.7 Statistical testing	75
3.7.8 Results	79
3.7.9 Conclusions	82
3.8 Earthwork Quantities	84
3.8.1 Introduction	84
3.8.2 Methodology	84
3.8.3 Conclusions	90
3.9 Vehicle Operating Costs	92
3.9.1 Introduction	92
3.9.2 Terrain Classification	93
3.9.3 Design Standards	93
3.9.4 Maintenance level	93

cont..	6.
3.9.5 Results	94
3.9.6 Conclusions	95
CHAPTER 4 MAINTENANCE MANAGEMENT	
4.1 Overview	98
4.2 Maintenance of Unpaved Roads	99
4.2.1 Introduction	102
4.2.2 Methodology	102
4.2.3 Results	106
4.2.4 Conclusions	106
4.3 Optimal Maintenance of Paved Roads	109
4.3.1 Introduction	109
4.3.2 Methodology	109
4.3.3 Results	109
4.3.4 Conclusions	109
CHAPTER 5 SUMMARY AND RECOMMENDATIONS	
5.1 Summary	113
5.2 Recommendations for Further Research	115
REFERENCES	116
APPENDICES	
Appendix A Cost data input	
Appendix B Vehicle Operating Costs vs Terrain	
Appendix C Grader Production, Grader Costs, Construction Costs	
Appendix D Traffic Compositions	
Appendix E Tradeoff between VOC and Grading Costs	
Appendix F Towards more Rational Drainage Factors	
Appendix G Tradeoff between Pavement Strength and Maintenance	
Appendix H Maintenance policies, Maintenance unit costs.	

LIST OF FIGURES

	Page.
1.1 Interplay of Major Cost Components	12
2.1 Transportation Tradeoffs	17
2.2 General Framework of the Highway Cost Model	26
3.1 Detailed Profiles	38
3.2 Equivalent Profiles as seen by the HCM	43
3.3 Different Approach Grades to 3% Grade	44
3.4 Cases with Equivalent Curvature	45
3.5 Range of Gradients through a Mountain	48
3.6 VOC vs. Gradients	50
3.7 Typical Cross Section	51
3.8 Earthworks vs. Length	52
3.9 Tradeoff between Extra Earthworks and Longer Route	57
3.10 Pavement Strength vs. Total Costs	61
3.11 Vehicle Operating Costs - Mountain Terrain, Extreme Design Standards	96
4.1 Tradeoff Faced by Maintenance Engineer	100
4.2 Tradeoff between Vehicle Operating Costs and Maintenance Costs	101
4.3 Cost Changes with Maintenance Efficiency	102
4.4 Generating Tree (Optimal Blading Frequency)	104
4.5 Tradeoff between VOC and Grading Costs	105
4.6 Generation Tree for Optimal Maintenance Policy for Paved Surfaces	110
4.7 Total Discounted Costs for Various Pavement Strengths and Maintenance Policies	111



LIST OF TABLES

3.1	Vehicle Operating Costs for Cases Depicted in Figure 3.1 (Paved)	40
3.2	Vehicle Operating Costs for Cases Depicted in Figure 3.1 (Gravel)	41
3.3	Vehicle Operating Costs for Cases Depicted in Figure 3.1 (Earth)	42
3.4	Vehicle Operating Costs for Cases Depicted in Figure 3.4	46
3.5	Vehicle Operating Cost Savings when Grade is Reduced - Paved Road Good Condition	52
3.6	Vehicle Operating Cost Savings when Grade is Reduced - Gravel Road Good Condition	53
3.7	Vehicle Operating Cost Savings when Grade is Reduced - Earth Road Good Condition	54
3.8	Range of Viable Grade Reduction Projects	56
3.9	Total Cost for Various Roadway Widths	64
3.10	Vehicle Operating Costs for Various Degrees of Curvature	65
3.11	Total Costs for Pavement Surfaces	67
3.12	Costs of Typical Surfacing	67
3.13	Design Standards by Maximum Grade	75
3.14	T-Statistics within Group Variations (Mountain)	76
3.15	T-Statistics between Terrain Categories Same Design Standards	77

LIST OF TABLES (CONTINUED)

3.16 T-Statistics between Design Standards	78
3.17 T-Statistics between Major Terrain Groupings for each Design Standard	80
3.18 T-Statistics between Design Standards for each Terrain Type	81
3.19 Design Input Parameters for Various Terrain	83
3.20 Earthworks vs. Terrain (IBRD)	84
3.21 Earthworks vs. Terrain (US. Forest Service)	85
3.22 Earthworks vs. Terrain (US. BPR)	86
3.23 Earthworks vs. Terrain (US. Interstate)	86
3.24 Earthworks vs. Terrain (Vance)	86
3.25 Earthworks vs. Terrain (Ethiopia)	87
3.26 Earthworks vs. Terrain (Australia Model)	88
3.27 Earthworks vs. Terrain (Soberman Model)	89
3.28 Earthworks vs. Terrain (Large Model)	90
3.29 Adopted Design Standards for each Terrain Type	91
3.30 Adopted Earthworks for Design Standard vs. Terrain	92
3.31 Input Parameters for Vehicle Operation Costs vs. Terrain	93
3.32 Road Condition Variables	94
4.1 Number of Vehicles between Bladings	108

## CHAPTER 1

### INTRODUCTION

#### 1.1 The Overall Budget for Transportation

The role of transportation is to provide the infrastructure which permits economic growth through the trading of goods. Time and cost expended in the conveyance of goods must be subtracted from the benefits of trade and only when the latter benefits are greater than the overall cost of transportation do overall gains accrue to the economy. Thus the aim is to provide the cheapest possible transportation given that the demand for transportation is a derived demand for some other economic activity which is desirable. The desirability of this base economic activity is taken into account when determining the overall budget for transportation.

The budget for transportation is determined by the particular nation's objectives and, until recently, the sole objective has been maximizing national income. Implicitly this means that a dollar spent, or earned, in any sector of the economy is equivalent. Thus the budget for transportation is primarily determined by the amount of the gross national product which will be invested and the returns from investments in all sectors of the economy.

Recently, with the realisation that there are other grounds for investment other than the purely national income objectives (e.g. regional income, income redistribution, environmental quality, etc.), the problem of financial distribution among government agencies has become more com-

plex requiring multiobjective analysis. The problem of determining the overall investment of funds rests with the governmental policy makers and, although he may influence it slightly, the transportation planner has little control over the final outcome and therefore must primarily work to optimize transportation costs within the allocated budget.

## 1.2 Project Analysis

The transportation planner is faced with two tasks; the first is to determine worthwhile projects and the second is to ascertain which of the projects should be built within the budget constraints. It is for the former task that the Highway Cost Model (HCM), and similar analytical tools, have been built.

In determining the project's feasibility, (net present value), for comparison with other projects the planner has to calculate three groups of costs--namely, construction costs, maintenance costs, and vehicle operating costs. A graphical representation of the interplay of the various costs is shown in Figure 1.1.

As construction costs rise, due to thicker pavements or better vertical alignment, the maintenance costs and vehicle operating costs fall. Similarly as maintenance costs increase with more intensive maintenance then vehicle operating costs fall.

As can be seen from the Figure and the foregoing brief discussion the planner has many options even within a given project. When it is

realised that each of the variables listed contains many other options (e.g. construction costs: more earthworks versus less pavement, manual labour versus machines, balanced design versus side borrow), the problem becomes immense even with computer based models. Because there are numerous variables involved that have undefined ranges of values even with computer based models, the search for optimality may be tedious and possibly fruitless. Thus it is necessary to restrict the search as much as possible by heuristics.

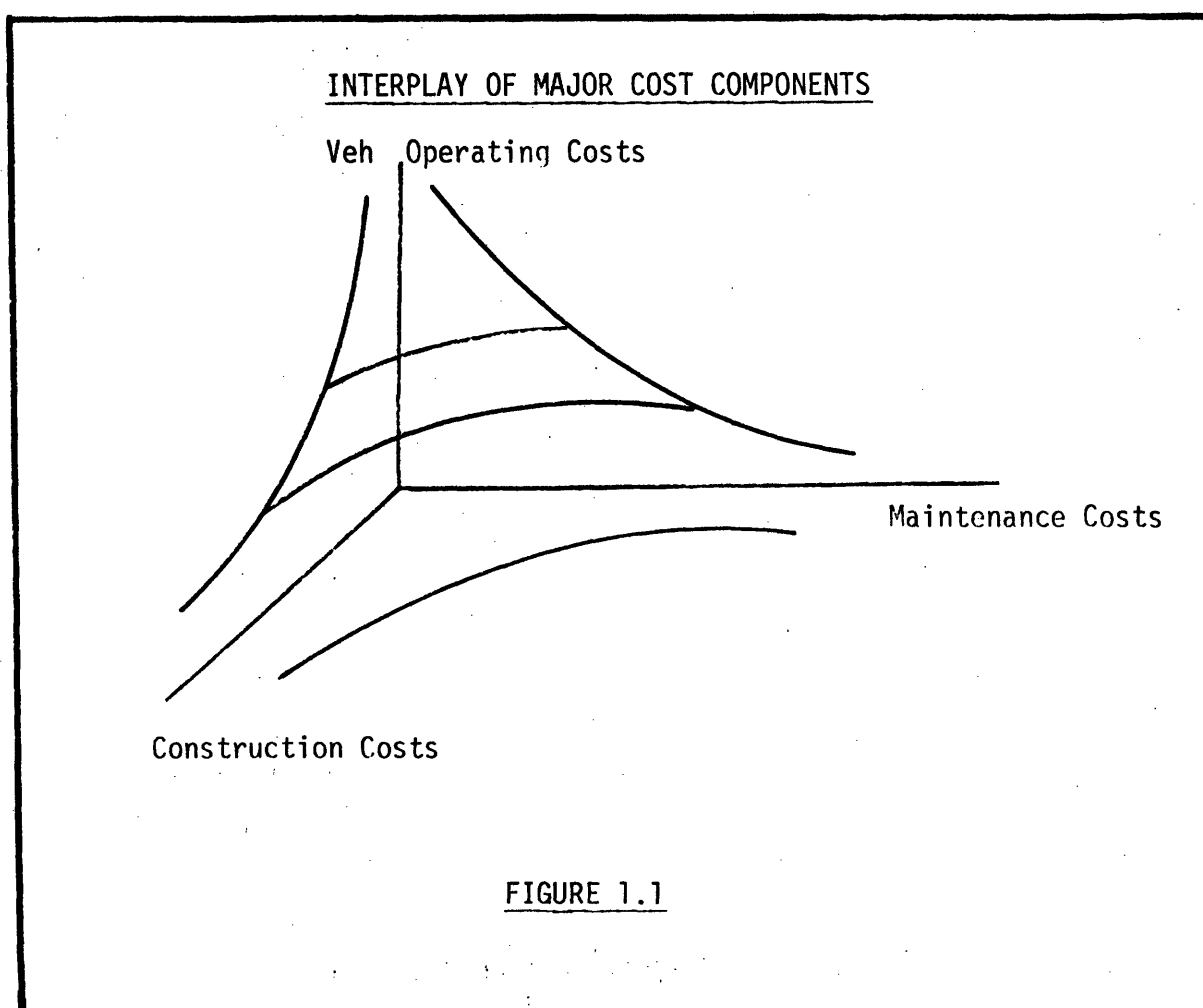

### 1.3 Heuristics

Highway engineering is continually evolving as vehicle specifications and relative costs within the highway industry change, and so design standards and design emphasis alter. The design standards that are in vogue today are in fact heuristically based. Heuristics rules are those which have been learned and they may take various forms.

Some rules may take the form of constraints on the range of values a variable may take and hence aid us in our search for optimality. An example of this type of rule is the optimal blading frequency of unpaved gravel roads, which limits the blading frequency to between 3000 and 6000 vehicle passes between bladings.

Other heuristics determine which variables are important and which may be neglected to simplify the problem. For example, in pavement design the number of truck axles is far more important than the number of passenger car axles and so in many cases the latter may be neglected.

Other heuristics enable the planner to choose between projects and alternative alignments without recourse to detailed analysis. For example if two projects are the same in all respects except one has a more severe vertical alignment, then the one with the lesser grades will be the better project.

### 1.4 Objective of Thesis

This thesis is aimed at extending the heuristic base of highway design and project analysis using the HCM to generate and evaluate many cases. This is one area that has been neglected in the past, with

most literature concentrating on theoretical aspects or general engineering. It is to fill the gap between the practical and the theoretical that this thesis has been written.

Another objective is to demonstrate the capabilities of the HCM to provide a basis for solving typical engineering questions which arise in roadworks planning. Some of the limitations of the HCM are explored. It is also hoped to demonstrate that the solutions obtained by exercising the HCM agree with traditional engineering practice.

The methodology adopted is generally to use the HCM to analyze a series of synthetic cases in which some of the many variables are held constant and the variables of interest are sensitivity tested. From these general studies, benchmarks are established and hence guidelines for particular cases can be found. A final objective is to establish which parameters are most important in the evaluation of projects so studies to establish better relationships can concentrate upon these variables.

### 1.5 Brief Outline

In Chapter 2 the framework of highway transportation is outlined and the important elements which will be the focus of the thesis are singled out for discussion. Also included in this chapter is a description of the HCM and a list of the sources of data used in the analyses.

The emphasis in Chapter 3 is focused on design aspects; the effects of geometry on vehicle operating costs and on construction

costs. Firstly, general design rules from accepted practice are outlined which touch on the field on route choice, detailed design and aesthetics. Then implications are drawn from the case studies done with the HCM along with some discussion of the limitations of the HCM. A framework for choosing between extra earthworks and lesser grades is then outlined. This is followed by a discussion of pavement design aspects exposed by the HCM. The value of staging, and the various thresholds for staging, are outlined again based upon many analyses using the HCM.

In many developing countries, the data required by the HCM for feasibility studies is not available and some guidelines are needed to generate synthetic data. Terrain evaluation techniques are outlined; these are examples of heuristic techniques where all the information we know is being used to give the best possible estimate for the unknown parameters for the case in question.

It should be noted that the distinction between what is design and what is maintenance is somewhat arbitrary. The two areas overlap substantially. For example a strong pavement design will reduce the need for maintenance.

The fourth chapter focuses upon implications for highway management primarily related to maintenance. After a brief introduction, the optimal blading frequency for unpaved roads is derived using some 1800 cases generated with the HCM. A modification to the regional factor is discussed in detail in Appendix F. Using this basis, the optimal policy for maintaining DBST roads is found using a prolific number of cases ana-



lyzed by the HCM.

The thesis concludes with a summary of findings and lists some areas for further research.

CHAPTER 22.1 GENERAL FRAMEWORK2.1.1 Transportation Costs

As stated in the introductory chapter, the costs incurred in highway transportation can be broken down into three categories, namely construction costs, maintenance costs and vehicle operating costs. Each of these costs is strongly linked with the others through the interaction between vehicles and the roadway. This interaction is depicted in Figure 2.1 below.

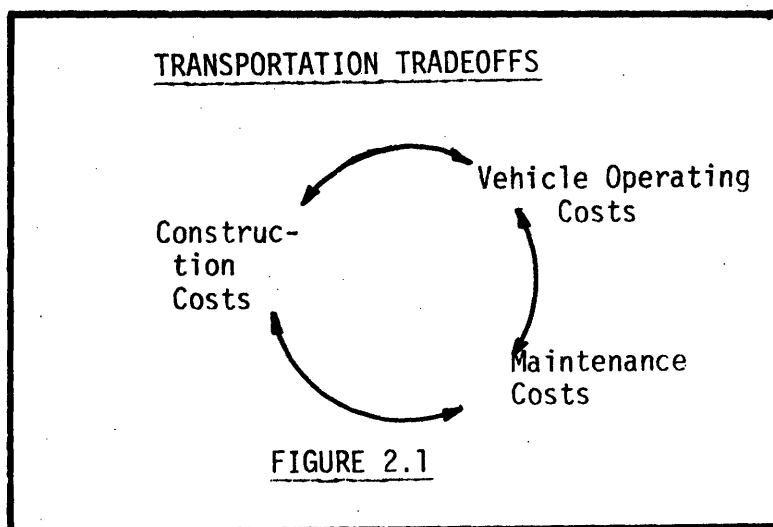

Although the tradeoffs involve all three dimensions simultaneously, for clarity, they will be discussed in the simplified two-dimensional form below.

### 2.1.2 Construction Costs

The two general tradeoffs of primary concern are construction costs versus operating costs and construction costs versus maintenance costs. These are the areas over which the planner has control, and so, they will be the primary focus of this thesis. A third category of some importance is the tradeoff between individual construction cost components. (e.g. manual methods vs. machine operations or subgrade strengthening vs. pavement thickness.) This third category is beyond the scope of this thesis, but the reader should be aware of its interplay with other variables.

#### Construction versus operating costs

1) Design profile vs. vehicle fuel and travel time costs: A road that closely follows the existing topography will have lower earthwork quantities and higher user costs than a road having lower profile grades relative to the natural topography. Since earthworks are generally the largest single component of construction costs and vehicle fuel consumption and travel time are the largest components of operating costs over which the designer has actual control, the tradeoff between maximum design grade and operating costs is both significant and important. Because these items are so important to the designer they were isolated and subjected to sensitivity testing in the chapter which follows.

2) Cross section design vs. operating costs: A major factor which influences construction costs is the width of the cross section and it also impacts upon vehicle operating cost through reductions, in vehicle speeds

when passing and more rapid deterioration of the pavement because of the narrower pavement. This tradeoff is not very important for low volume roads as lane restrictions are not as binding, because there is little oncoming traffic. To substantiate this conclusion some runs were done with the HCM and they are included in the chapter on design aspects.

3) Pavement design vs. operating costs: The major item which links all three cost categories together is pavement design as it is the pavement-vehicle interaction which is basic to transportation. The links between pavement and maintenance and construction and maintenance will be discussed in later sections. It is through the vehicle-pavement interaction that the operating costs are generated and hence where operating costs are important the approach has been to concentrate on those parameters which correspond to the surface condition of the roadway. Pavement roughness and rut depth are functions of the original pavement design and both influence the desired free speed and the actual vehicle operating costs and so these are the variables input to enable evaluation of this tradeoff.

4) Construction costs vs. time: All the various tradeoffs are operating within the time framework dictated by the life of the pavement and so time adds another dimension to the analysis. Because future costs are discounted, it is sometimes better overall to build the project in stages thus moving some of the capital expenditure on construction into the future. This tradeoff in the time frame is investigated in the chapter on design as it is an important aspect that should not be overlooked by the designer or planner.

### Construction versus maintenance costs

1) Pavement design vs. maintenance costs: The tradeoff here is relatively obvious; the stronger the initial pavement, the less the maintenance required to achieve a reasonable serviceability rating throughout the pavement lifetime for a given traffic set. The influence of pavement design on maintenance costs is discussed briefly in Chapter 3 and then in more detail in Chapter 4.

2) Pavement cross section vs. maintenance costs: The basic dimensions of the cross section influence the maintenance requirements. Increasing the width, while lowering operating costs, increases both construction and maintenance costs. The effects of cross section width have largely been excluded from this study and generally a fixed cross section has been assumed; the exception to this is the discussion of widenings in the section dealing with stage construction which appears in Chapter 3.

3) Drainage design vs. maintenance costs: Drainage often proves to be an important problem in the operation of low-cost roads. Inadequate initial drainage design, especially in tropical conditions, may result in the actual closing of road during times of high precipitation and runoff, or exceptionally high maintenance costs to keep the road open and in good condition. Drainage design includes not only culverts and structures to allow cross-flow of streams but also parallel roadway ditches to remove or prevent water from building up on the roadway and soaking into the pavement and subgrade structure. As can be seen from the discussion of water effects on pavement strength, (Appendix F), this

is a major concern and should not be overlooked by the engineer in the field. All analyses performed within the body of this thesis assume competent design of drainage facilities.

### 2.1.3 Maintenance Costs

Again the primary tradeoffs are between maintenance costs versus construction costs and maintenance costs versus vehicle operating costs. As with construction costs there is again the tradeoff between individual components of maintenance costs, for example manual labour vs. machine, or various application rates for seal coats. Again this category is beyond the scope of this thesis and is best left to the practising engineer who is more familiar with the details involved at this level of tradeoff.

#### Maintenance versus construction costs

The basic tradeoff between maintenance and construction costs have been discussed previously under the corresponding section. From this aspect, however, given the maintenance policy to be practised, then the pavement thickness, for example, can be adjusted prior to construction.

#### Maintenance versus operating costs

The impact of maintenance on operating costs is primarily through the surface condition of the pavement. The smoother the pavement as a result of maintenance, the lower the operating costs, hence the ap-

proach has been to concentrate upon the effect of maintenance in reducing roughness and rut depth; the parameters used to describe pavement condition.

1) Unpaved roads: For unpaved roads the primary maintenance operation which reduces surface roughness is grading. This operation is studied in some detail in Chapter 4.

2) Paved roads: The major objective of patching and seal coats is reduce the ingress of water into the pavement structure and hence increase pavement life. Pavements weakened by water will become rougher and vehicle operating costs will increase, thus the exclusion of water is vital. As this type of environmental influence is the primary reason for maintenance operations on paved roads, these effects have been pursued at length in Chapter 4 and Appendix F.

Routine maintenance operations such as drain cleaning have not been studied although they are also important in increasing roadway life. If drains are not cleared then catastrophic washouts will occur in heavy rains. However, the nature and extent of the damage is probabilistic depending upon flood return periods and the condition of the drains at the time. Because the relative merits of different policies cannot be assessed reasonably, this type of maintenance will not be explored in this thesis.

Further, routine maintenance activities such as brush control are not discussed, as these have little impact on the major cost tradeoffs.

#### 2.1.4 Vehicle Operating Costs

Vehicle operating costs include the following categories:

1. Journey time and related costs
2. Fuel consumption
3. Vehicle wear

Each of these is explicitly considered in the HCM and hence all the analyses in this thesis.

The tradeoffs between vehicle operating costs and construction and maintenance costs have been discussed previously, however, it should be noted that the effect is two-way.

1) Vehicle operating costs vs. construction: If large savings in user costs are possible, then more extensive construction projects can be justified. These tradeoffs are investigated in the chapter devoted to design impacts.

2) Vehicle operating costs vs. maintenance: Similar to above, if large vehicle operating cost savings are possible through maintenance, then intensive maintenance policies may be justified. These aspects are discussed in Chapter 4.

Individual vehicle types are not considered separately and, in fact, most of the work in this thesis is done with typical traffic mixes which are then subjected to sensitivity testing.



## 2.2 Analytic Framework

The analyses throughout this thesis which have been done using the Highway Cost Model (HCM) as a basis and a description of HCM framework, follows.

The function of the HCM is to calculate total costs of roadworks projects by calculating construction, maintenance and user costs as they occur during the lifetime of the facilities. This is done by simulating the life of the road from initial construction, through periodic upgrading, the yearly cycle of use, deterioration, and maintenance. The basic structure of the model is shown in Figure 2.2.

The simulation is accomplished by determining construction and maintenance activities to be performed, and by estimating road conditions, traffic volumes and all associated costs on a year by year basis through the analysis period. For most of the analyses in this thesis, hypothetical case studies were performed in which some of the variables were sensitivity tested while others were held constant. The specific operation undertaken in each year are as follows:

A construction submodel schedules projects, allocates a percentage of construction costs to the current year, and updates the status of the link as projects are completed. The various types of projects which may be undertaken include new construction, pavement reconstruction or overlaying, widening and realignment.

A traffic submodel makes a preliminary estimate of the current year's traffic based on the previous year's traffic and anticipated growth.

DATA REQUIREMENT

National or Regional Parameters

Design Standards  
 Geometric standards  
 Pavement sections  
 Material characteristics

Maintenance Standards  
 Routine maintenance criteria  
 for earth gravel and  
 paved roads  
 Resurfacing criteria

Highway Program Parameters

Construction Unit Costs  
 Maintenance Unit Costs  
 Basic Vehicle Ownership and  
 Operating Costs

Project Parameters

Traffic  
 Physical Characteristics of  
 the Alignment  
 Specific Design and Maintenance  
 Standards to be Studied  
 Schedule for Implementation

SIMULATION OF ROAD LIFE CYCLE

For each year in analysis  
 period

Estimate costs for road  
 construction or upgrading  
 based on design standards and  
 construction unit costs

Update the status of the road  
 based on project completions

Preliminary estimate of this  
 years traffic

Estimate road deterioration  
 effects of maintenance, costs,  
 and average surface conditions

Estimate user costs based on  
 geometric standards, surface  
 type and surface conditions

Update traffic projections  
 based on actual user costs

FIGURE 2.2

A road deterioration and maintenance submodel estimates the average road surface conditions for the year as a function of the initial design standard, last year's surface conditions, the volume and composition of the traffic during the current year, the local environment, and the specified maintenance policy. Surface deterioration may be estimated for both paved and unpaved roads.

A range of typical maintenance activities may be specified for each surface type on either a scheduled or a demand responsive basis and those are priced according to the amount of maintenance which is actually performed. The condition of the road is expressed in terms of roughness, rut depth, cracking and patching (paved roads), and looseness and moisture content (unpaved roads).

The user cost submodel estimates the costs of operating vehicles over the road as a function of surface type and conditions, and design geometrics (grade, horizontal curvature and road width). The components of vehicle operating costs include both running costs (fuel, oil, tyres, etc.), and time costs (depreciation, insurance, etc.). Operating cost estimates are prepared for a fleet of vehicles representative of those which will actually be using the road.

The results of the simulation include a record of expenditures incurred by the Highway Authority for capital improvements and maintenance, a record of the costs incurred by road users, and a detailed history of the status and deterioration of the road. Construction and maintenance costs are broken down into labour, equipment, materials, overhead and profit components by line item. Vehicle operating costs including:

fuel, oil, tyres, maintenance parts and labour, depreciation, and other time and utilization costs are estimated for each type of vehicle using the road.

All estimates are made in terms of physical quantities, from which total costs are obtained by applying the appropriate unit rates. The model is therefore not dependent on the use of a particular monetary system. Costs are estimated in both economic and market terms.

The model has evolved from research at MIT and the Transportation and Road Research Laboratory and details of this growth and of the detailed relationships can be found in Reference (18).

### 2.3 Data Sources

The primary data used was that typical for Ethiopia and the sources used were:

\*Ortega, NG (Reference 21) for vehicle operating costs

\*Wyatt, R and Sheffi, Y. (Reference 26)

and \*Harris, F. (Reference 9) for all other costs.

The other data were from the various case studies performed by MIT and IBRD and the primary sources of their data were consultant reports. The data sources are listed below.

Malawi - Berger, F. (Reference 5)

Tanzania - Bhandari, A. (Reference 6)

Upper Volta - Ohbi, K. (Reference 19)

The vehicle operating costs used are listed in Appendix A and the maintenance costs used, appear in Appendix H.

CHAPTER 3  
DESIGN APPLICATIONS

3.1 OVERVIEW

In this chapter the tradeoffs which can be affected by designers and planners are researched to extend the heuristic base already established in the design field. These tradeoffs are almost exclusively in the construction cost versus vehicle operating cost realm as outlined in Chapter Two. The first section outlines the general rules of design that are in vogue today. In the following section, some of the shortcomings of the HCM as a detailed design tool are examined and it is concluded that the alignments selected should be modified in the light of the general rules of existing practice at the detailed design level.

The tradeoff between construction costs and user costs is then explored in the context of location and route choice. Simple rules are given at the conclusion of this section to aid the planner in route evaluation.

Next, the parameters involved in the construction-cost user cost tradeoff were tested and those found to be crucial are listed. This is followed by a section on stage construction in which many of these crucial parameters are varied to enable evaluation of the various strategies.

The chapter concludes with series of sections which involve terrain evaluation techniques. Firstly, the existing terrain categories are tested to see if they are statistically valid and then typical values for design parameters are calculated. The second section discusses construction aspects for each terrain category by finding expected earthwork

quantities for each design standard and terrain grouping. Finally, vehicle operating costs are calculated for each terrain category for a range of maintenance levels and vehicle types.

## 3.2 GENERAL DESIGN RULES

### 3.2.1 Introduction

With the growth of computer based models such as the Highway Cost Model, planners and designers can now consider many more alternatives than was previously possible. In many cases, however, by the use of the established rules of route location, the number of alternatives considered may be reduced and the best alternative determined without resort to the computer, thus saving expenditure. It should also be mentioned that the performance of the computer packages is determined by the ability of the planner to generate viable alternatives. (i.e., the computer can only select the optimum solution if it is among those input.)

Unfortunately, the Highway Cost Model structure prevents the designer from distinguishing between two alternatives if they only differ marginally at the detailed design level. These problems and some approximate solutions will be discussed in more detail in a later section. Generally, however, one method of choosing between designs at the detailed level is to use the established rules of design. These design rules are also useful in translation from the chosen prefeasibility corridor to the detailed design profile.

Aesthetics are not considered explicitly by the Highway Cost Model; however, if the simple rules which follow are borne in mind by planners

and designers, then a better final design, more acceptable to the community, will result at minimal extra cost.

Many of the rules which follow cannot be satisfied simultaneously by a route, and the planner or designer must choose to satisfy those which are most critical for the particular case being studied.

### 3.2.2. General Rules of Route Location

- 1) The highway should be sited such that it best satisfies the travel demand. The nature of the facility being planned should be kept in mind as townships may not act as primary control points for major highways but they may be controls for secondary roads.
- 2) The effect of each route location on the surrounding network must be considered.
- 3) A unique bridge site or mountain pass may constitute primary control for all alternatives to be considered.
- 4) Grades and curvatures should be kept to the minimum necessary, provided construction and maintenance costs are not increased.
- 5) In some cases, it may be desirable to locate a new highway or an existing route to minimize right-of-way cost and avoid unnecessary duplication of the network links which will lead to increased network maintenance costs.
- 6) It is desirable to locate through the edges of properties to limit severance.
- 7) One should be aware of utilities which may require relocation.

- 8) Favorable river crossings should be sought.
- 9) Areas where bedrock is near the surface should be avoided as this will probably lead to increased construction costs and may lead to problems with ground water in the shallow soil cover.
- 10) Avoid bogs, marshes and low lying areas subject to flooding.
- 11) Be aware of possible landslides.
- 12) To minimize drainage problems select a location on high ground rather than one in a valley.
- 13) Locate the highway on soil which will require the minimum pavement thickness.
- 14) Locate near the source of pavement materials.
- 15) Where all other conditions are met, the best location is one that minimizes earthworks total cost. This generally means that the minimum quantities of excavation should be so balanced with the quantities of embankment as to require a minimum haulage with little need for overhaul. Note that the haulage distances should be those appropriate for the technology which is to be adopted. Designs for highly labor intensive construction should differ substantially from those which are capital intensive.
- 16) In hilly terrain the highway should cross ridges at their lowest points as this will generally result in cheaper construction and user costs.
- 17) In areas subject to snow falls, select a location subject to sunlight to avoid areas where snow and ice may accumulate.
- 18) Avoid ground subject to mining subsidence.



- 19) Avoid placing the highway at right angles to the natural drainage channels in rolling terrain.
- 20) The least expensive and frequently the most direct line is one which lies just above the high water level of streams. If the rise of the stream is greater than the maximum permissible grade, then extra length must be gained.
- 21) In desert areas the roads should preferably be parallel to the dune and valley lines and either have a clear unobstructed right-of-way to ensure free carriage of sand by the wind, or a wind break should be established.

### 3.2.3 Detailed Design Rules

- 1) Aim for balance and consistency in design standards so that the various geometric features conform with driver expectation.
- 2) Do not have roads intersecting on small radii horizontal or vertical curves.
- 3) Avoid sudden changes in sight distance especially near junctions.
- 4) The "hidden-dip" type of profile should be avoided. Even with shallow dips, this type of profile can be disconcerting because the driver cannot be sure whether or not there is an oncoming vehicle beyond the rise. This type of profile is avoided by horizontal curvature or by more gradual grades made possible by heavier cuts and fills.
- 5) Grades should be reduced when curvature is involved.
- 6) It may be desirable to have upgrades preceded by downgrades to

allow heavy trucks to operate at higher overall speeds. One should be aware, however, that this type of grade line may encourage excessive speeds by trucks with the attendant hazard to other traffic.

- 7) On long grades it is preferable to place the steepest grades near the top of the ascent.
- 8) Climbing lanes should be considered where the critical length of grade is exceeded and the DHV warrants are met.
- 9) It is desirable to reduce the gradient through intersections as such a profile change is beneficial for all vehicles making turns and serves to reduce potential hazards.
- 10) Sharp horizontal curvature should not be introduced at, or near, the top of a pronounced vertical curve as this is hazardous.
- 11) Similarly, sharp horizontal curves should not be introduced at the bottom of sags as this gives a distortion effect and it may result in erratic behavior especially at night.
- 12) On two-lane highways the need for safe passing sections may override the most favorable combination of horizontal and vertical alignment.
- 13) Short curves and/or tangents should not be used; horizontal and vertical curves should be as long as possible; adjacent curves should be of similar length.
- 14) In hilly topography the radii of the crests should be greater than the sags in order to obtain the best possible visibility in the region of the crests. In level terrain which varies up

up to 10 meters in elevation, in addition to visibility conditions, the sag radii should, to obtain an optically satisfactory alignment, be greater than the radii of the crests.

#### 3.2.4. Aesthetics

- 1) Vertical curvature superimposed upon horizontal curvature or vice versa generally results in a more pleasing facility but it should be analyzed for the effects upon traffic
- 2) Changes in horizontal and vertical alignment should be phased to coincide wherever possible. Phasing means that horizontal and vertical curves must be nearly equal in their length and their respective beginning and end points should be coincident. (Ratios of horizontal to vertical curvature greater than 1 to 5 should be avoided.) Phasing becomes increasingly important when using horizontal curves sharper than 7000 feet radius and vertical curves of less than 50,000 feet radius.
- 3) Flowing alignments can most readily be achieved by using curves in preference to tangents.
- 4) Care should be taken to obtain smooth flowing edge profiles when applying or removing superelevation.
- 5) Compound curves should be avoided.
- 6) Curvature and grades should be in proper balance. Long straights in rugged terrain and excessive curvature with flat grades both give a poor appearance.
- 7) A smooth grade line with gradual changes, as consistent with the

class of highway and character of terrain is preferable to a line with numerous breaks and short lengths of grades.

- 8) A broken-back grade line (two vertical curves in the same direction separated by a short section of tangent out grade) should generally be avoided, particularly in sags, for it has a poor appearance.
- 9) If the alignment follows a short rise in the ground without producing an invisible stretch of road ahead, the impression of a bulge in the roadway is created. If a number of such bulges are visible simultaneously, the resulting optical image appears to flutter.
- 10) Small changes of direction should not be made as they give the perspective of the road a disjointed or kinked appearance.
- 11) Avoid creating severe breaks in the natural skyline with large cuts and fills.
- 12) The road should curve when passing through wooded areas to preserve an unbroken background.
- 13) To relieve the monotony of driving on a straight road, it is an advantage to site it so as to give a view of some prominent feature ahead.
- 14) Cuts less than 10 feet high generally have their slopes flattened for aesthetic reasons.
- 15) Earthworks should be smoothly contoured so that the roadway will appear less artificial. Slope rounding improves appearance.

### 3.2.5. General Points

- 1) Some thought should be given to the surface area of cuts and embankments as the maintenance costs of these areas will be roughly proportional to the surface area.
- 2) The slopes of embankments and cuts should be such to allow easy mowing if this type of right-of-way maintenance is contemplated.
- 3) Leave local drainage patterns as unaltered as possible.
- 4) Consideration should be taken of the method of handling existing traffic during construction where this may be a problem.
- 5) Elimination of control of excessive subsurface moisture should be considered in the route location and pavement design.
- 6) The water table must always be kept well below the formation to prevent capillary moisture rising into the compacted subgrade.
- 7) It may be unwise to compromise geometric features for the sake of economy as other features such as pavement strengthening and widening are much more easily stage constructed.
- 8) The use of floodways, and/or floodway-culvert combination gives an opportunity to stage drainage facilities.

### 3.3. SHORTCOMINGS IN THE HIGHWAY COST MODEL AVERAGING APPROACH

#### 3.3.1. Rise and Fall

A. Because the HCM adopts average rise and fall per kilometer as an input parameter, it has limited application as a design tool.

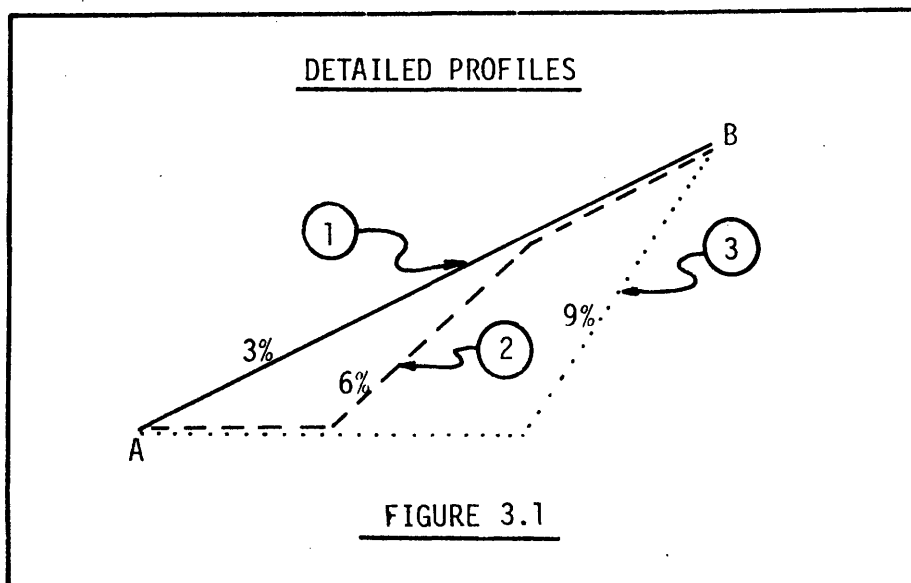

In the case depicted in Figure 3.1, if the input to the HCM is the rise between A and B, then the vehicle operating costs are calculated as if the profile is given by Case 1. If the profile is known in more detail, then intermediate points can be input to give profiles 2 or 3. The trade-off is between the number of segments and the accuracy of the vehicle operating costs. If the terrain is rugged and there is a tendency to adopt low design standards with steep grades as depicted by Case 3, then using the average rise and fall will generally underestimate the "true" vehicle operating cost.

An approximate method of correcting for these discrepancies is simply to factor user costs depending upon the design standard being used and the ruggedness of the terrain.

For example, if the terrain and design standards are such that 3-6% grades are used and profiles that are similar to Case 2 exist (i.e., part of the profile has a grade slightly higher than the average grade), then a correction of 4% could be made to the large bus operating costs with other vehicles' costs left essentially unchanged. See Tables 3.1, 3.2, and 3.3. If a lower design standard is used and terrain is more rugged and profiles such as Case 3 exist (i.e., part of the profile has a grade significantly steeper than the average grade), then a correction of 8% could be added to all vehicle categories other than large buses where a 20-30% additional cost is incurred and passenger cars where no correction is required. (See Tables 3.1, 3.2 and 3.3)

Two further observations are that the discrepancy will be much higher if value of time is included and that the discrepancies appear to be largely independent of surface type.

VEHICLE OPERATING COSTS FOR CASES DEPICTED FIG. 3.1 (PAVED)

CASE	<u>VEHICLE TYPE</u>						OVERLOAD 22T TRK
	<u>PASS CAR</u>	<u>27P BUS</u>	<u>60P BUS</u>	<u>5T TRK</u>	<u>10T TRK</u>	<u>22T TRK</u>	
UP 1	105	204	405	219	360	507	525
	---	---	---	---	---	---	---
UP 2	104	209	428	226	370	519	536
	(0)	(2)	(6)	(3)	(3)	(2)	(2)
UP 3	104	229	528	253	409	566	582
	(0)	(12)	(30)	(16)	(14)	(12)	(11)
DOWN 1	90	162	300	171	300	441	459
	---	---	---	---	---	---	---
DOWN 2	90	162	300	172	301	442	458
	(0)	(0)	(0)	(0)	(0)	(0)	(0)
DOWN 3	90	161	300	173	301	442	458
	(0)	(0)	(0)	(0)	(0)	(0)	(0)
BOTH 1	195	368	705	390	660	948	984
	---	---	---	---	---	---	---
BOTH 2	195	371	728	398	671	961	994
	(0)	(1)	(3)	(2)	(2)	(1)	(1)
BOTH 3	195	390	828	426	710	1008	1040
	(0)	(6)	(17)	(9)	(8)	(6)	(6)

PAVED ROAD (good condition)

TABLE 3.1

- NB. 1) Costs in Ethiopian cents per kilometer.  
 2) Figures in parentheses are the percent change from case 1 profile.



VEHICLE OPERATING COSTS FOR CASES DEPICTED FIG 3.1 (GRAVEL)

CASE	<u>VEHICLE OPERATING COSTS</u>						OVERLOAD 22T TRK
	<u>PASS CAR</u>	<u>27P BUS</u>	<u>60P BUS</u>	<u>5T TRK</u>	<u>10T TRK</u>	<u>22T TRK</u>	
UP 1	135	279	525	294	483	678	699
	---	---	---	---	---	---	---
UP 2	136	286	562	302	496	694	715
	(0)	(3)	(7)	(3)	(3)	(2)	(2)
UP 3	136	318	781	343	559	770	790
	(0)	(14)	(99)	(17)	(16)	(14)	(13)
DOWN 1	120	231	393	237	411	597	618
	---	---	---	---	---	---	---
DOWN 2	119	230	394	236	411	597	618
	(0)	(0)	(0)	(0)	(0)	(0)	(0)
DOWN 3	119	230	395	235	411	600	618
	(0)	(0)	(0)	(0)	(0)	(0)	(0)
BOTH 1	255	510	918	531	894	1275	1317
	---	---	---	---	---	---	---
BOTH 2	255	516	956	538	907	1294	1333
	(0)	(1)	(4)	(1)	(1)	(1)	(1)
BOTH 3	255	547	1176	578	970	1370	1408
		(0)	(7)	(28)	(9)	(7)	(7)

GRAVEL ROAD (good condition)

TABLE 3.2

- NB. 1) Costs are in Ethiopian cents per kilometer  
 2) Figures in parentheses are the percentage change from Case 1.

VEHICLE OPERATING COSTS FOR CASES DEPICTED FIG. 3.1 (EARTH)

CASE	<u>VEHICLE TYPE</u>						<u>OVERLOAD 22T TRK</u>
	<u>PASS CAR</u>	<u>27P BUS</u>	<u>60P BUS</u>	<u>5T TRK</u>	<u>10T TRK</u>	<u>22T TRK</u>	
UP 1	147	303	546	312	519	729	750
	---	---	---	---	---	---	---
UP 2	148	310	584	322	532	747	768
	(0)	(2)	(7)	(3)	(3)	(2)	(2)
UP 3	148	346	814	367	599	828	849
	(0)	(14)	(49)	(18)	(15)	14)	(13)
DOWN 1	132	252	414	255	444	648	669
	---	---	---	---	---	---	---
DOWN 2	131	252	413	255	445	648	669
	(0)	(0)	(0)	(0)	(0)	(0)	(0)
DOWN 3	131	252	413	255	445	648	669
	(0)	(0)	(0)	(0)	(0)	(0)	(0)
BOTH 1	279	555	960	567	963	1377	1419
	---	---	---	---	---	---	---
BOTH 2	279	562	998	577	977	1395	1437
	(0)	(1)	(4)	(2)	(1)	(1)	(1)
BOTH 3	279	597	1227	622	1044	1476	1518
	(0)	(8)	(28)	(10)	(8)	(7)	(7)

EARTH ROADS (good condition)

TABLE 3.3

- 1) Costs in Ethiopian cents per kilometer
- 2) Figures in brackets are the percentage change from Case 1 profile.

B. Because the HCM treats each segment separately, it is unable to distinguish between the two profiles shown in Figure 3.2 on the basis of vehicle operating costs

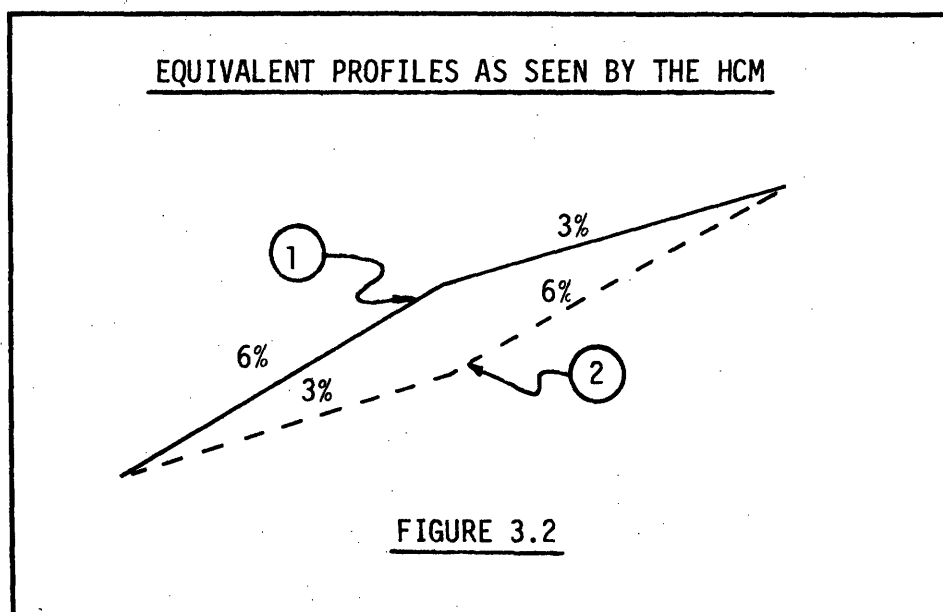

As was pointed out in the general design rules, it is generally desirable to have the steeper portion of the grade at the bottom and then go to flatter grades near the crest of the hill. This is done to improve visibility over the crest but also to allow vehicles to maintain higher speeds which should lead to lower operating costs.

Thus, the HCM does not differentiate entirely between alternatives on a detailed level and general design rules should be used in such cases.

C. Further, the HCM cannot distinguish between the operating cost on the 3% grade section for the cases below although the operating conditions are markedly different. See Figure 3.3.

To improve the HCM, the vehicle speed achieved at the end of each

segment should be carried forward into the next segment.

From the detailed design aspect, the approach of adopting limiting lengths for grades as set out in the AASHO Manual should be adopted.

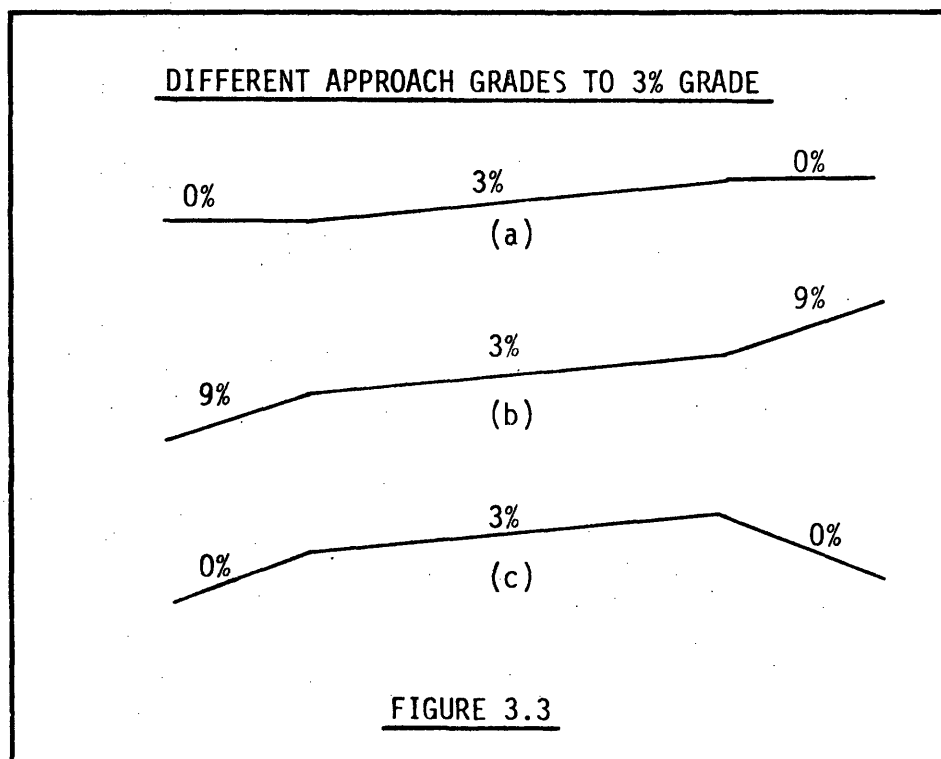

### 3.3.2. Curvature

A. Again the use of the HCM is limited as a design tool because of the input being of an average value. Thus the HCM is unable to distinguish between the cases shown in Figure 3.4 although from experience one would expect the sharper curve to incur higher costs as brake and tire wear would be higher and speeds lower. See Table 3.4.

CASES WITH EQUIVALENT CURVATURE

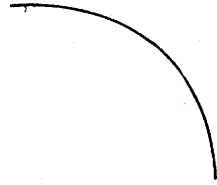

a)  $90^\circ/\text{km}$



b)  $90^\circ/\text{km} = 1/2(180^\circ/\text{km} + \text{Str.})$

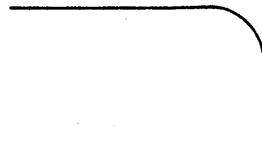

c)  $90^\circ/\text{km} = 3.75(240^\circ/\text{km}) + 0.625 \text{ Str.}$

FIGURE 3.4

VEHICLE OPERATING COSTS FOR CASES DEPICTED FIG. 3.4

	<u>VEHICLE TYPE</u>						<u>OVERLOAD 22T TRK</u>
	<u>PASS CAR</u>	<u>27P BUS</u>	<u>60P BUS</u>	<u>5T TRK</u>	<u>7T TRK</u>	<u>22 T TRK</u>	
<u>PAVED</u>							
(a)	32	58	112	62	106	154	159
(b)	32	58	113	63	106	154	159
(c)	32	58	114	63	107	155	160
<u>GRAVEL</u>							
(a)	42	82	143	85	145	209	215
(b)	42	82	143	85	145	210	216
(c)	42	83	144	86	146	210	217
<u>EARTH</u>							
(a)	46	90	149	92	156	226	232
(b)	45	90	150	92	157	227	233
(c)	46	91	150	93	158	227	234

TABLE 3.4

NB. Costs in Ethiopian cents

### 3.3.3. Conclusions

The HCM has limitations as a detailed design tool and it has a tendency to underestimate costs in situations where the grade and/or curvature is severe. Used in conjunction with simple design rules, and taking the aforementioned underestimation into account, the HCM should provide an adequate base for comparison between alternative projects.

### 3.4 LOCATION AND ROUTE CHOICE

#### A. TRADEOFF BETWEEN EXTRA EARTHWORKS AND LESSER GRADES

##### 3.4.1a Introduction

A problem which faces designers and planners of highways is the choice between lesser grades, which will yield larger user cost savings, and the high construction cost which these lesser grades incur through higher earthwork quantities. The tradeoff is depicted in Figure 3.5.

Should the engineer choose alignment A or alignment B?

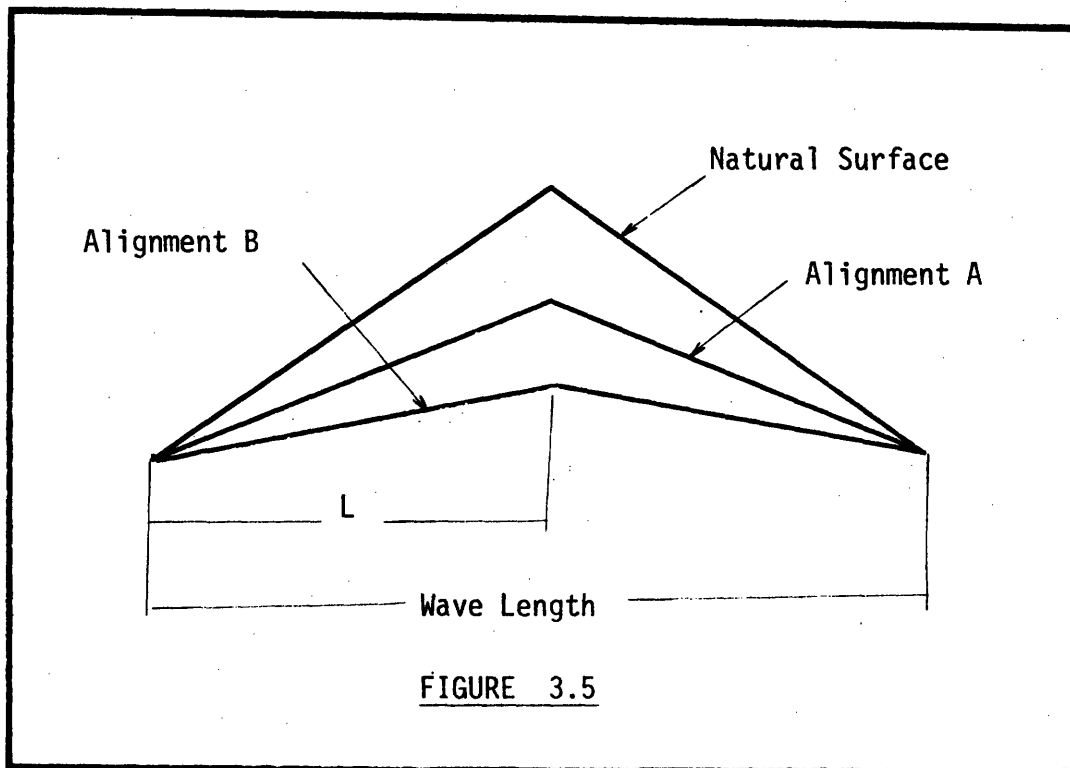

FIGURE 3.5

##### 3.4.2a Methodology

To investigate this problem, a series of case studies were generated and evaluated using HCM. Ethiopian cost data were used throughout, but the methodology is valid internationally and the conclusions reached are general enough to have validity in other countries where costs and



vehicle fleets are similar.

The vehicle operating costs (See Appendix [A]) on various grades were found for a typical vehicle composition for Ethiopia (See Appendix [D]). The results for 100 ADT and  $L = 1$  km are shown in Figure 3.6. The savings in vehicle operating costs as a result of reducing the gradients for the various surfaces are listed in Tables 3.5, 3.6 and 3.7. It should be noted that these differentials are for grades one kilometer long, and so they overestimate savings for shorter grades and underestimate savings for longer grades.

Earthwork quantities were then computed approximately using the formula

$$Q = \left[ \frac{W}{2} + (g_{old} - g_{new})L \right] (g_{old} - g_{new})L^2 \times 2$$

Q.....Total earthworks quantity ( $m^3$ )

W.....Formation width (Assumed 9.8m)

$g_{old}$ ...Old gradient

$g_{new}$ ...New proposed gradient

L .....Length as depicted in Figure 3.5 (Half wavelength)

NB Sideslopes were assumed to be 2 to 1.

It should be noted that a slight error is introduced by the use of this formula as the shaded area shown in Figure 3.7 is neglected. This error is not that critical as it would be compensated by the use of steeper sideslopes on deeper cuts.

Curves for earthwork quantities v. length 'L' were then calculated for various gradient changes (i.e.,  $g_{old} - g_{new}$ ). See Figure 3.8. Then, assuming a discount rate of 10%, zero traffic growth rate, and typical

VOC v. GRADIENT

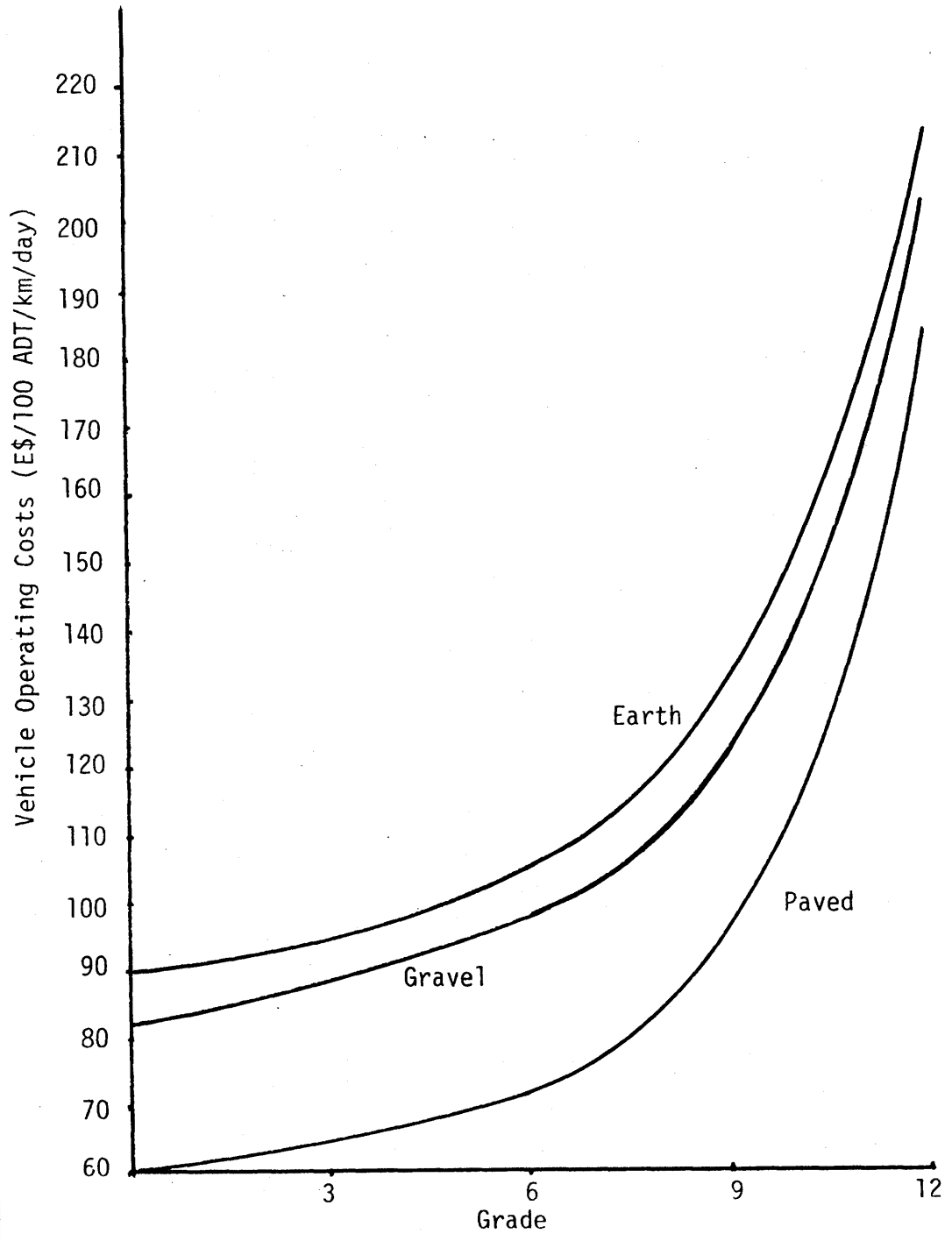
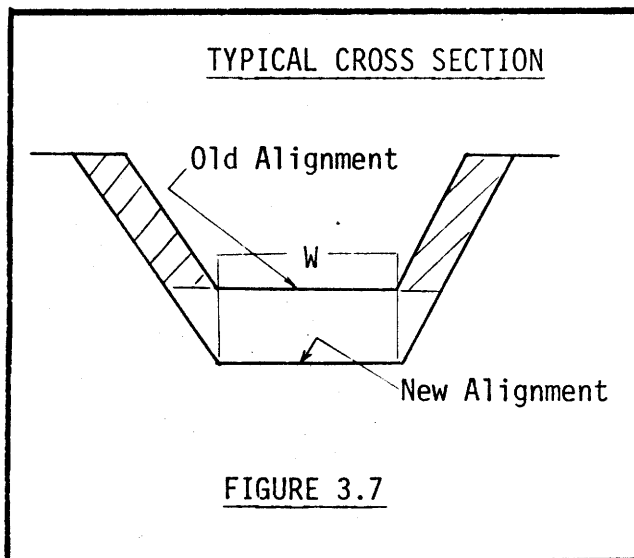

FIGURE 3.6



Ethiopian earthwork costs (Reference 26), the range of ADT and Length 'L' could be found for which the project was worthwhile. These results are listed in Table 3.8. For a project which reduces a grade of 6% to 5% say, to be viable, 1000 ADT is required for  $L = 100\text{m}$ . Higher ADT's are required for  $L > 100\text{m}$  and lower ADT's if  $L < 100\text{m}$ .

#### 3.4.3a Conclusions

Although the preceding calculations contain many assumptions about relative prices and traffic composition, etc., it is apparent that relatively few grade reducing projects are worthwhile unless they are short, (Wavelength  $< 300\text{m}$ ), the reduction is substantial, the original grade is steep, and traffic volumes are above 200 ADT.

This emphasizes the fact that when vehicle operating costs are used to justify projects the earthworks should be in the same relative magnitude as the ADT. For example, high earthwork quantities can generally only be justified by high ADT's. Therefore, as most developing nations have roads which have only low ADT's, earthworks should be kept to the minimum possible. One way to do this is to resort to lower design

---

<u>Old Grade</u>	<u>New Grade</u>							
	<u>0%</u>	<u>1%</u>	<u>2%</u>	<u>3%</u>	<u>4%</u>	<u>5%</u>	<u>6%</u>	<u>7%</u>
1%	0.5							
2%	1.7	1.2						
3%	3.8	3.3	2.1					
4%	4.2	3.7	2.5	0.4				
5%	7.7	7.2	6.0	3.9	3.5			
6%	10.5	10.0	8.8	6.7	6.3	2.8		
7%	14.7	14.2	13.0	10.9	10.5	7.0	4.2	
8%	22.7	22.2	21.0	18.9	18.5	15.0	12.2	8.0
9%	25.8	25.3	24.1	22.0	21.6	18.1	15.3	11.1

VEHICLE OPERATING COST SAVINGS WHEN GRADE IS REDUCED  
 PAVED ROAD GOOD CONDITION  
 (E\$/100 ADT)

TABLE 3.5

---

---

<u>Old Grade</u>	<u>New Grade</u>							
	<u>0%</u>	<u>1%</u>	<u>2%</u>	<u>3%</u>	<u>4%</u>	<u>5%</u>	<u>6%</u>	<u>7%</u>
1%	0.9							
2%	2.4	1.5						
3%	5.1	4.2	2.7					
4%	7.2	6.3	4.7	2.1				
5%	10.8	9.9	8.4	5.7	3.6			
6%	14.0	13.1	11.6	8.9	6.8	3.2		
7%	19.0	18.1	16.6	13.9	11.8	8.2	5.0	
8%	27.0	26.1	24.6	21.9	19.8	16.2	13.0	8.0
9%	38.1	37.2	35.7	33.0	30.9	27.3	24.3	11.1

VEHICLE OPERATING COST SAVINGS WHEN GRADE IS REDUCED  
 GRAVEL ROAD GOOD CONDITION  
 (E\$/100 ADT)

TABLE 3.6

---

---

<u>Old Grade</u>	<u>New Grade</u>							
	<u>0%</u>	<u>1%</u>	<u>2%</u>	<u>3%</u>	<u>4%</u>	<u>5%</u>	<u>6%</u>	<u>7%</u>
1%	0.9							
2%	2.7	1.8						
3%	5.0	4.0	2.2					
4%	6.9	6.0	4.2	2.0				
5%	9.9	9.0	7.2	5.0	3.0			
6%	14.2	13.2	11.4	9.2	7.2	4.2		
7%	20.9	20.0	18.2	16.0	14.0	11.0	6.8	
8%	28.9	28.0	26.2	24.0	22.0	19.0	14.8	8.0
9%	40.8	39.8	38.0	35.8	33.8	30.8	26.6	19.8

VEHICLE OPERATING COST SAVINGS WHEN GRADE IS REDUCED  
 EARTH ROAD GOOD CONDITIONS  
 (E\$/100 ADT)

TABLE 3.7

---

EARTHWORKS v LENGTH

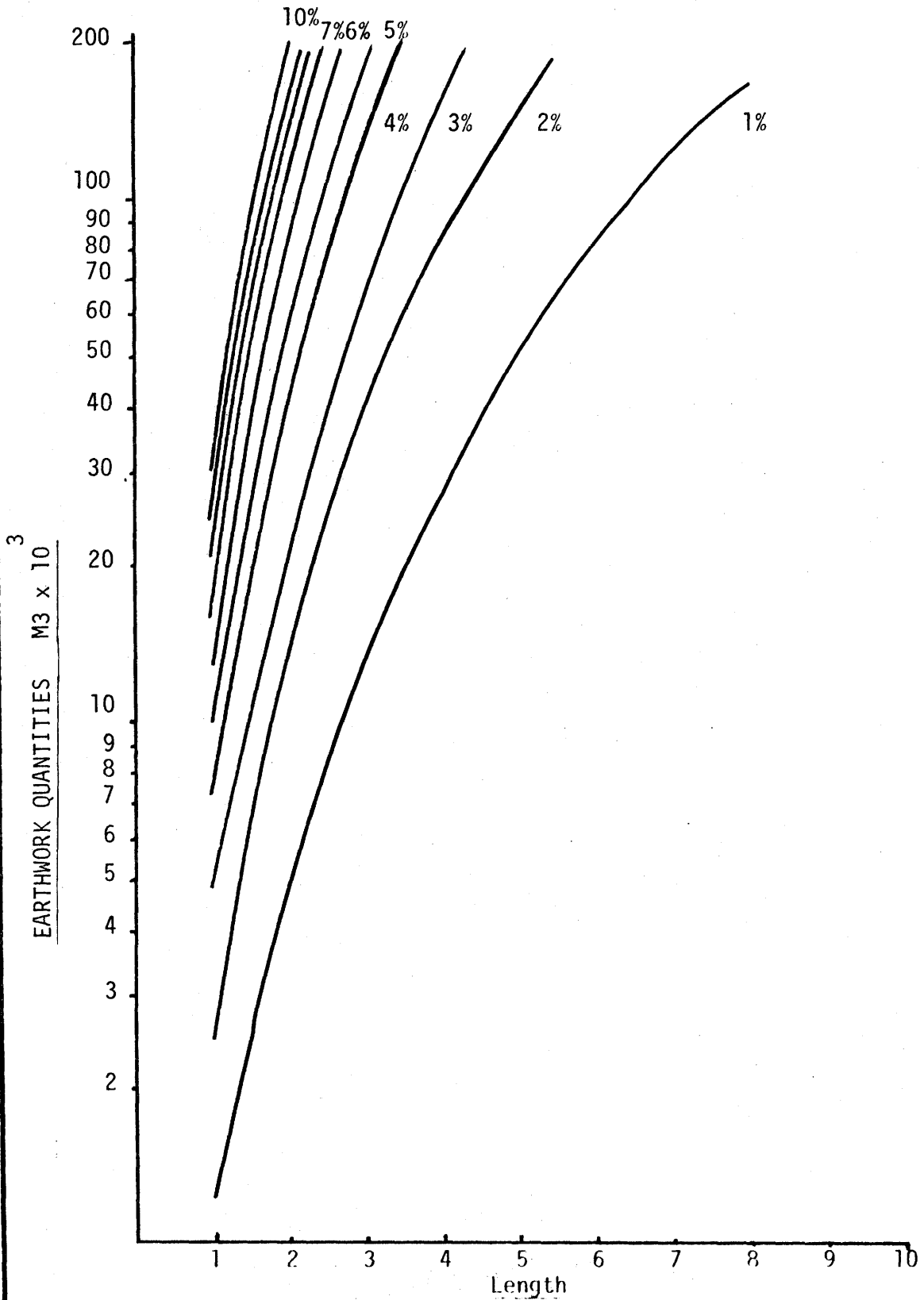

FIGURE 3.8

RANGE OF VIABLE GRADE REDUCTION PROJECTS

<u>Reduction in Gradient</u>	<u>Original Grade (Gold)</u>	<u>ADT - Length Range</u>
1%	0-7%	1000 ADT for 100 m
1%	>8%	1000 ADT for 150 m or 500 ADT for 100 m
2%	2-5%	1000 ADT for 100 m
2%	6-7%	750 ADT for 100 m
2%	8-9%	1000 ADT for 200 m or 250 ADT for 100 m
3%	3-4%	1000 ADT for 100 m
3%	5-6%	750 ADT for 100 m
3%	7-9%	1000 ADT for 200 m or 250 ADT for 100 m
4%	4%	1000 ADT for 100 m
4%	5-6%	1000 ADT for 150 m or 500 ADT for 100 m
4%	7%	1000 ADT for 150 m or 333 ADT for 100 m
4%	8-9%	1000 ADT for 220 m or 200 ADT for 100 m
5%	5%	1000 ADT for 150 m or 500 ADT for 100 m
5%	6%	1000 ADT for 160 m or 333 ADT for 100 m
5%	7%	1000 ADT for 200 m or 250 ADT for 100 m
5%	8%	1000 ADT for 220 m or 200 ADT for 100 m
5%	9%	1000 ADT for 230 m or 150 ADT for 100 m
6%	6%	1000 ADT for 150 m or 333 ADT for 100 m
6%	7%	1000 ADT for 200 m or 250 ADT for 100 m
6%	8-9%	1000 ADT for 230 m or 150 ADT for 100 m
7%	7%	1000 ADT for 200 m or 250 ADT for 100 m
7%	8-9%	1000 ADT for 230 m or 150 ADT for 100 m

TABLE 3.8



standards where the terrain dictates.

It can be seen from Tables 3.6 and 3.7 that the savings in vehicle operating costs for grade reduction projects on unpaved roads will be greater than those on paved roads. However, unpaved roads generally carry far lower ADT ( $ADT < 400$ ), and so projects of this nature are less likely.

## B. TRADEOFF BETWEEN EXTRA EARTHWORKS AND LONGER ROUTE

### 3.4.1b Introduction

Another familiar problem to planners of highways is the choice between extra length or extra earthworks. The problem is depicted in Figure 3.9. Should the planner choose route 1 or route 2?

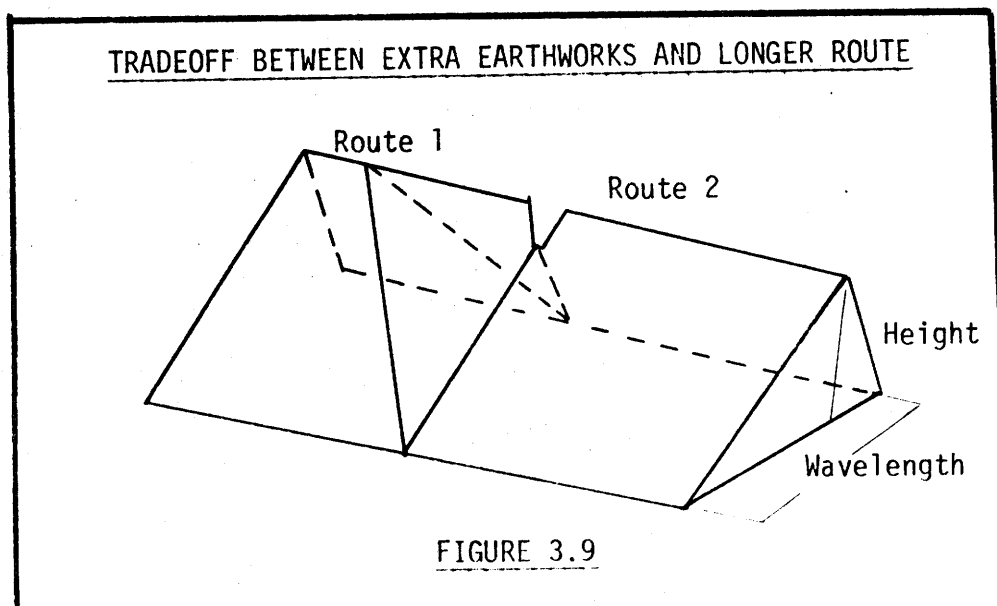

### 3.4.2b Discussion

This problem is extremely difficult to simplify as there are such a wide range of options. For example, what should be the ruling grade on route 1 and route 2? Are they the same? What are the respective surface types, maintenance policies on the routes? Then there is the range of

wavelengths, peak heights and traffic compositions. Hence, each problem is best evaluated on its merits as has been done in the various case studies.

### 3.4.3b Conclusions

From the case studies performed, it seems that the methodology to evaluate route location should be as follows

- 1) Look at the most direct route. If it can be designed within the accepted range of ruling grades (i.e., <10%) with necessary earthworks only, then this route should be adopted.
- 2) Modify the grades on the direct route depending upon ADT as outlined in the previous section.
- 3) If the most direct route requires substantial earthworks to keep the vertical alignment within the accepted standards, then alternative routes should be sought. Using general design rules outlined in the previous section (i.e., cross at saddle points, etc.), alternative routes can be generated. Of these alternatives, again the shortest route will be the best if the earthwork quantities for all routes are similar.

A general conclusion is that for cuts and fills over 20m, an ADT of > 1000 is required to make this amount of earthworks worthwhile rather than using a slightly more tortuous route.

Thus, for low volume roads, the direct route with minimal earthworks is the best solution, followed by the next most direct

route with average earthworks and a tortuous route with minimal earthworks.

### 3.5 CRUCIAL PARAMETERS

#### 3.5.1 Geometric Parameters

From the case studies performed to date, it has been found that project total costs are generally insensitive to geometric parameters if the designer stays within accepted design standards. This confirms that the standards used at present are well founded. However, it should be recognized that the relationships used in the HCM were developed within the existing standards and hence are somewhat limited. The insensitivity to changes in vehicle operating costs as design standards alter can be explained by the drop in fuel consumption as speed is decreased toward 30 km/hr; this counters the increase in travel time.

Further, the changes in total costs are relatively insensitive to design standards because the savings in vehicle operating costs induced by higher design standards are offset by the increase in construction costs required by the higher design standards. In this situation, the choice between design standards depends upon investment policy. That is, should the cost of transportation be borne by the public sector by conforming to high standards or should the private sector pay the costs in the form of increased vehicle operating costs? The HCM is not capable of making such policy decisions as it is simply an evaluation tool for planners.

From the studies, it was also confirmed that vertical alignment is far more important than horizontal alignment in determining vehicle operating

costs.

There has been no case study done involving narrow formation widths, but the equation in the HCM, based on TRRL research in Kenya, shows that there is no effect on speed if the formation width is greater than 5 metres.

Thus it has been found that the total cost is relatively insensitive to all geometric features except length, and to find in favour of high design standards value of time has to be introduced.

The implications for design which follow from the case studies are:

- 1) Lengths should be as short as possible while remaining within the existing design standards.
- 2) The HCM is not sensitive enough to differentiate between designs at the detailed design level and hence, it should be used in conjunction with the general design rules outlined previously.
- 3) When value of time is included higher design standards should be adopted.

### 3.5.2. Pavement Design

The implications for pavement design which follow from the studies with the HCM are the same as found in practice . Namely, the thickness of pavement required is very sensitive to the number of heavy truck axles, and the overall performance of the pavement is determined by its strength (structural number). It was found that a weak pavement design cannot be offset by intensive maintenance (See Figure 3.10), and where high growth rates are anticipated, it may be desirable to over design slightly as this

PAVEMENT STRENGTH v TOTAL COSTS

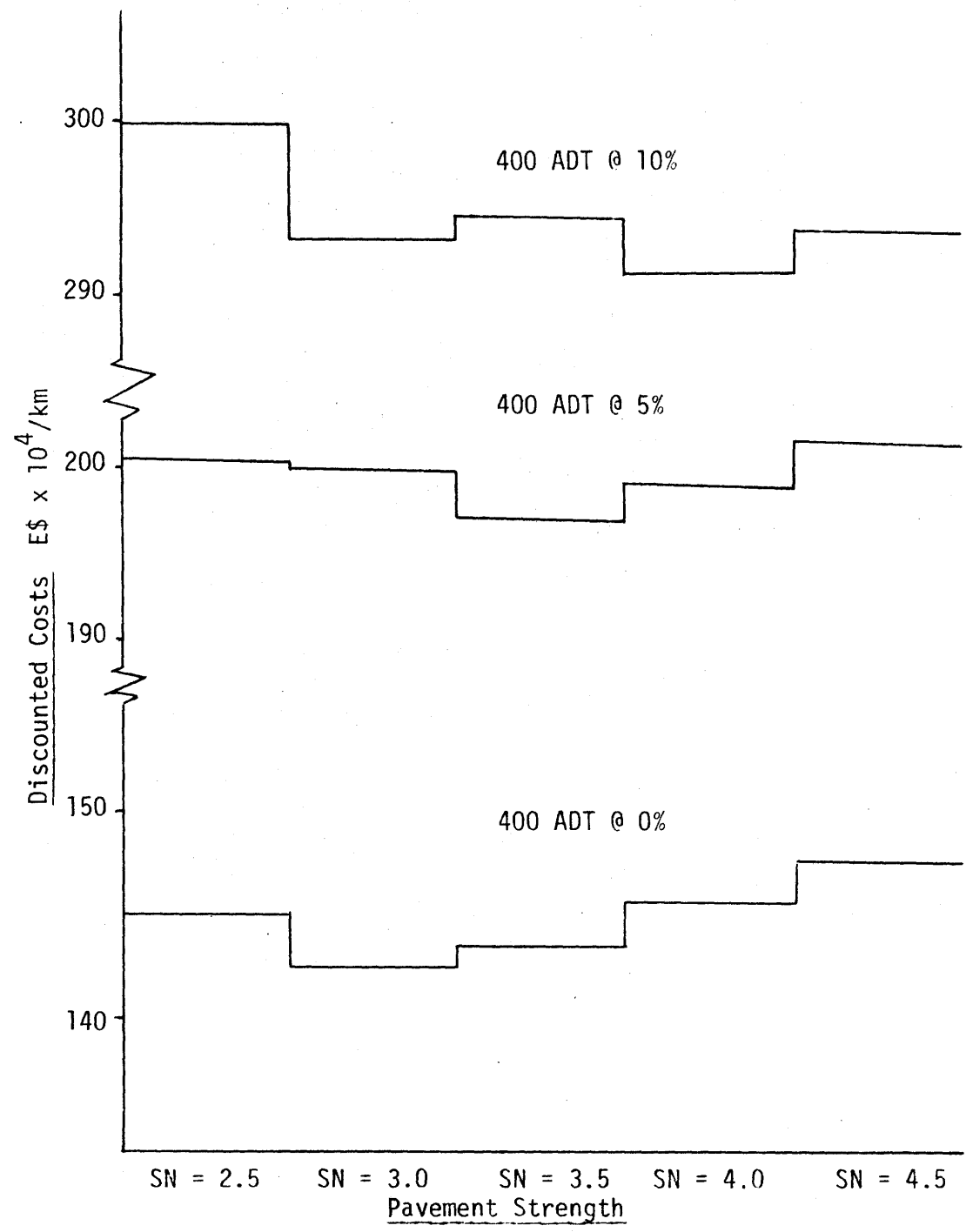

FIGURE 3.10

NB Intensive Maintenance

has only a marginal increase in total cost over the optimal design.

(See 400 ADT @ 10%, Figure 3.10).

Reiterating, from the studies performed, the crucial parameters for pavement design were found to be pavement thickness (structural number) and number of heavy truck axles which traverse the road.

### 3.5.3. Interest Rate

The optimal policy was found to be very dependent upon the discount rate used, particularly in the case of staging policies. The model user must be fully aware of the effects of discounting, and rather than discounting at a single rate, it is suggested that a range of rates be used to more fully display discounting effects.

The usual effects of discounting are evident in the HCM, in that for low discount rates larger capital expenditures can be justified for initial construction and for high discount rates projects are more difficult to justify. The reason for this is simply that projects are justified on user cost savings, which are annual savings, and the discount rate impacts dramatically on the present value of an annual stream of benefits.

## 3.6 STAGING

### 3.6.1 Introduction

Stage construction is a procedure whereby the road is built to a level to meet immediate requirements of traffic and at a later date is reconstructed or upgraded to meet the increased demands of traffic. One advantage is the lower present value of construction costs as the

immediate investment is reduced and future investments are discounted. Another advantage is that it allows investments on the basis of observed traffic flows rather than on predicted volumes which may not eventuate. The disadvantage, however, is that setup costs are incurred each time an upgrading is performed.

Stage construction may take many forms as listed below:

- 1) Changes in roadway width
- 2) Changes in vertical or horizontal alignment.
- 3) Changes in surface type.
- 4) Changes in pavement thickness.
- 5) Combinations of the above.

It is proposed to study each of the above in turn to determine worthwhile staging strategies.

### 3.6.2 Width

The TRRL Study done in Kenya (Ref. 10) found that speed was only reduced when the road width fell below 5m. Their equation is mimicked in the HCM and so there are no benefits with respect to vehicle speed for any widening over 5m.

The width also enters the deterioration phase via the road width factor, which apportions vehicles and equivalent axles according to whether the road behaves like a one-lane, or two-lane road, or something in between.

Some test runs were made varying the width to determine whether or not staging the width was feasible given the benefits computed by the HCM,

as in practice usually saving in accident costs are listed as the major reason for widenings, and the HCM does not take account of these benefits as they are small on low volume roads. 64.

The results are shown in Table 3.9. It must be kept in mind that these results are for a specific situation; namely, pavement strength (SN = 3.5), traffic volume = 400 ADT, growing at 5 percent, and an intensive maintenance policy. As expected the results show that widenings are not viable at low traffic volumes if the road pavement is strong and well maintained.

---

TOTAL COST FOR VARIOUS ROADWAY WIDTHS

PAVEMENT WIDTH

<u>Costs</u>				
(000's E\$)	<u>4.00m.</u>	<u>5.00m.</u>	<u>6.00m.</u>	<u>7.20m.</u>
Construction Increase	--	16.63	33.26	53.22
Maintenance	35.19	34.60	31.32	37.59
Operating	1317.44	1310.81	1308.38	1308.38
TOTAL	<u>1352.</u>	<u>1362.</u>	<u>1373.</u>	<u>1399.</u>

TABLE 3.9

NB: Pavement SN = 3.5  
Traffic 400 ADT growing @ 5 percent  
Intensive Maintenance

---

3.63 Vertical Alignment

It was found in the analysis performed in the section which discussed



extra earthworks versus lesser grades the benefits to be gained by reducing the gradients are small unless traffic volumes are high. The vertical profile should be determined by the traffic volume, and unless this has been badly underestimated, or earthwork unit costs fall dramatically, the vertical profile should not be staged independently of other changes, say pavement thickenings or widening. The benefits from grade changes are small, and adding set-up charges to the costs make these projects less attractive, also the pavement must be removed and recompactd which can be expensive.

#### 3.6.4 Horizontal Alignment

The benefits gained by changes in horizontal alignment are very small. Table 3.10 lists the vehicle operating costs by vehicle type for each surface type for various degrees of curve.

TABLE 3.10  
VEHICLE OPERATING COSTS FOR VARIOUS DEGREES OF CURVATURE

	<u>VEHICLE TYPE</u>					
	<u>Pass Car</u>	<u>27P Bus</u>	<u>60P Bus</u>	<u>5T TRK</u>	<u>10T TRK</u>	<u>22T TRK</u>
<u>GOOD PAVED</u>						
90°/km	.32	.58	1.12	.62	1.06	1.54
180°/km	.32	.59	1.21	.64	1.09	1.58
240°/km	.32	.60	1.28	.65	1.12	1.60
<u>GOOD GRAVEL</u>						
90°/km	.41	.82	1.43	.85	1.45	2.09
180°/km	.41	.85	1.51	.89	1.51	2.16
240°/km	.41	.87	1.58	.92	1.56	2.22
<u>GOOD EARTH</u>						
90°/km	.45	.90	1.49	.92	1.57	2.26
180°/km	.45	.93	1.58	.95	1.63	2.33
240°/km	.45	.95	1.64	.99	1.68	2.39

As for vertical alignment it can be seen that a large ADT is needed to make these projects viable on vehicle operating cost savings grounds and again in practice accident reduction is generally cited as the reason for curve reduction. For both types of alignment change, the lengths involved are generally short, and to offset set-up costs, they are usually timed to correspond with other staging activities such as pavement reconstruction.

### 3.6.5 Surface Type

A change in surface type is planned to reduce both user costs and maintenance costs. Figure 3.11 shows the relative changes in user costs for earth, gravel, and paved surfaces in level terrain. As can be seen from these results and Table 3.11 well maintained earth roads provide as cheap a solution as gravel roads, but this is an aberration in the HCM. Earth roads are only feasible in areas where the CBR is high, and the lack of support of heavy axle loads is not captured in the HCM. It is because of the lack of support of subgrades that expensive pavement materials are used for gravel and DBST pavements. Therefore, the reason for staging an earth road to gravel is not primarily to capture the small user savings benefits (ADT's using unpaved roads are too low to make this figure significant), but rather to prevent exorbitant maintenance expenditures required by catastrophic subgrade failures.

One should consider ungrading an earth road to a gravel road when subgrade failures become prevalent. These will occur if there is a significant percentage of trucks and/or, there is demand for transport in the rainy season. From experience, any road carrying 40 ADT, or more, should be considered for upgrading, although a lower threshold ADT is applicable if there is a large proportion of trucks or the native

subgrade is weak.

67.

As can be seen from Table 3.11, the break even volume for upgrading from gravel to a paved surface is about 200 ADT, but this varies with construction costs and discount rates and a more general range is 150 - 400 ADT.

<u>TOTAL COSTS FOR PAVEMENT SURFACES</u>						
<u>TRAFFIC VOLUME (ADT)</u>						
	<u>50</u>	<u>100</u>	<u>200</u>	<u>300</u>	<u>400</u>	<u>600</u>
<u>EARTH</u>	12336	24672	49344	74016	98688	148032
<u>GRAVEL</u>	16107	28354	52848	77342	101836	150824
<u>PAVED</u>	22253	32603	53303	73983	94643	135983

TABLE 3.11

Notes:

- 1) E\$/km
- 2) Flat straight section
- 3) Maintenance : Earth optimal blading only.  
Gravel optimal blading and gravel replacement  
Paved optimal maintenance.
- 4) All maintenance costs exclusive of routine maintenance.
- 5) Construction costs for pavements and sealing only.
- 6) Typical Ethiopian traffic composition.

COSTS OF TYPICAL SURFACINGS

EARTH                      Voc. E\$ 24272/100 ADT/year  
Mnt. Blade every 1600 veh. passes @ E\$18/blading  
Total E\$400/100 ADT/year.

GRAVEL

Voc. E\$23,754/100 ADT/year.

68.

Mnt. Blade every 5500 veh passes @ E\$18/blading E\$120/100 ADT/year.

Gravel loss 5mm/100 ADT/year = E\$620/100 ADT/year

Total E\$740/100 ADT/year.

Const. Pavement: 30 cm depth x 72 width x E\$12/m<sup>3</sup> x annuity factor 10% E\$3860/km/year.

PAVED

Voc. E\$20655/100 ADT/year

Mnt. Optimal Policy (see later section)

200 ADT = E\$90/year

400 ADT = E\$120/year

600 ADT = E\$150/year

Const. Pavement = 30cm depth x 72 width x E\$29-7/m<sup>3</sup> x annuity factor 10% E\$9546/km/year

Sealing 7 ? width x E\$2-2 m<sup>2</sup> x annuity factor @ 10% \$2357/km/year.

Total E\$11,903/km/year

TABLE 3.12

Case studies done by M.I.T. and the World Bank have concentrated on the break even volume between gravel and paved surfaces. In the Upper Volta study, (Ref. 13) it was concluded that with 160 ADT initially growing at 8 percent, a gravel surface provided the cheapest solution. In the Malagasy study, (Ref. 2), the breakeven volume was found to be 260 ADT; but it was pointed out there was low sensitivity and the range lay between 150 - 400 ADT. In the case of Asela - Dodola (Ethiopia), (Ref. 26), paving was found to be worthwhile in year 10 for an initial ADT of 200 growing at 7 percent annually.

### 3.6.6 Pavement Thickness

69.

Upgrading the pavement thickness is usually restricted to paved roads, and is one of the most frequent type of staging employed. Overlays are the best method of upgrading the thickness as they incur relatively minor set-up costs. Pavement materials are generally one of the largest cost items in road construction and so stage construction is reasonable.

In the section on optimal maintenance policies, it appears that there is little benefit to be gained by staging, but this is not true as in fact staged overlays have been employed to achieve the results cited.

### 3.6.7 Conclusions

The most worthwhile types of staging are those which involve either surface upgrading or pavement thickening, as the first allows savings in vehicle operating and maintenance costs once the threshold ADT is reached, while the other simply continues to match the pavement thickness to existing traffic as traffic grows, saving in the initial investment in thick expensive pavements.

Many of the staging projects related to geometry are only marginally viable and should be staged with other types of upgradings to help offset the set-up costs.

Further, it has been determined that there is little sensitivity in total costs between staging policies, rather the result is an expenditure shift from the public to the private sector. For example, if a gravel road is paved then the construction cost is met from public funds and user costs are reduced but this has largely the same total cost as a road which is not upgraded where the bulk of the cost is now user costs borne by the private sector.

### 3.7 TERRAIN CLASSIFICATION

#### 3.7.1 Introduction

The traditional approach for evaluating highway projects has been to obtain contour maps of the area in question and design alternative routes in more, or less, detail depending upon whether the study was at the feasibility or prefeasibility level respectively. For each alternative studied, construction, user, and maintenance costs were evaluated and the cheapest alternative was selected. The number of alternatives studied was severely curtailed by the sheer magnitude of the computational effort required. Further, in some cases the data base was poor and some relationships used were of doubtful validity.

The Highway Cost Model and its offspring, the Network Cost Model have provided a better conceptual framework and, by virtue of their computer base, enable rapid evaluation of many more alternatives than was previously viable. However, because of the many alternatives that are now evaluated, especially in the case of the network cost model, simplification is required in the traditional approach of gathering input data. In the case of feasibility studies the level of detail required to enable differentiation between alternatives dictates that the traditional approach or something closely akin to it has to be followed. For prefeasibility studies however, where such detail is not required a system of terrain classification suggests itself as a means of circumventing the time consuming method traditionally used.

The method of terrain classification is simply to categorize and store information about similar existing situations. Knowledge of the category of the terrain of the immediate problem allows access to the historical data which is then used as the data base. This approach

is simply applying the principles of inductive logic in that we use all our existing knowledge to determine expected values in the new situation; categorization simply limits the search of the historical data set.

### 3.7.2 Research Aims

Terrain classification is not a new approach, it has, and is, being used extensively by many highway authorities throughout the world. What is it then that makes this research different?

Present day terrain classifications have evolved rather than been formulated and so there has been little attempt to establish more quantifiable classifications. Classifications such as mountainous, hilly, and flat are used with subsequent users adopting their own rules to establish each grouping's boundary. An attempt is made in this research to delimit each category using simple measureable parameters.

Further there has been little effort made to validate if there is any significant difference between classifications. The average values of parameters contained within each classification can be tested against the corresponding values in another classification using the students t-test and statistical difference established. If no statistical significance between parameters of categories exists then the categories should be combined into a single classification.

Finally, the interaction of design standard and terrain type has generally been ignored. Primarily this is because for most studies the design standard is presumed to be an exogenous input into the design process. In this research design standards are considered as explicit inputs. The approach is feasible as a result of the ability to consider more alternatives via the computer based models.

### 3.7.3 Methodology

72.

The ultimate data base would have been one where terrain was classified and the parameters of interest for the various design standards were available. Alternatively a series of hypothetical case studies could be designed over terrain typical of each classification.

The methodology adopted was tempered by expediency, as in the former case the data was not available, and in the latter, many man hours of design would have been required to provide sufficient data. The method used was to classify areas on USGS maps by terrain type and then to determine the road parameters for existing roads.

### 3.7.4 Terrain Classification

The terrain classification adopted for this research was as used by the North Atlantic Division, US Corps of Engineers for the NAR study of water resources. For this study terrain was divided into broad categories and then each of these was further subdivided as shown below.

#### Mountainous

Dominant vertical dimension; at least 2000 feet of relative elevation between valley floor and ridge line or peak with jagged or pointed profile.

M-1...Conical peaks randomly distributed in long and short rows.

M-2...Serrated linear ridges with occasional angular peaks.

M-3...Densely clustered pyramidal peaks

M-4...Long undulating ridges surrounded by lower conical peaks

M-5...Continuous linear ridges and occasional scattered conical peaks.



### Steep Hills

High hills rising steeply from the base plane, ranging in height from 800 to 2000 feet above the adjacent base plane, usually with a strong vertical dimension and a rounded profile.

SH-1...Individual and connected hills of varying height and size.

SH-2...Serpentine valleys along major rivers and tributaries frequently interrupted by secondary ravines.

SH-3...Long unbroken serpentine valleys

SH-4...Linear rounded hills varying in height

### Rolling Hills

Rounded hills with an apparent horizontal dimension ranging in height from 200 to 800 feet, low to moderate slopes and rolling profile.

RH-1...Hills of uniform shape but varying height hills interspersed with some undulating land.

RH-2...Rounded hills varying in size

RH-3...Flat, rolling hills varying in height and shape.

RH-4...Large, uniformly shaped hills.

RH-5...Hills varying in height and shape

RH-6...Irregularly shaped hills with generally uniform height.

### Undulating Lands

Variation in the horizontal ground plane without identifiable hill forms.

UL-1...Linear depressions at regular intervals

UL-2...Random distribution at irregular depressions.

### Flat Land

Dominant horizontal dimension with little or no variation in the ground plane.

FL-1...Little or no relief with many marshes.

This classification is far more detailed than those used to date for roadworks however it was anticipated that statistical testing would confirm that many groups could be combined.

#### 3.7.5 Road Parameters

The road parameters gathered for each case were:

- (a) The ratio of direct distance to the route distance
- (b) The degrees of curve per kilometer to route distance.
- (c) The degrees of curve per kilometer to direct distance.
- (d) The total sum of rise and fall per kilometer at direct distance.
- (e) The total sum of rise and fall per kilometer of route distance.

#### 3.7.6 Design Standards

There was no information as to the design standards of each road studied and, as the maximum allowable grade and minimum allowable radius, the usual specifications of design standards, may not have been reached for a particular design, two approaches were adopted.

Firstly, the design standards were determined by the road use classification given in the legend of the maps. Medium Duty, Light Duty, Unimproved Earth. It was reasoned that there would be strong correlation between classifications and the design standards used.

The second approach was to classify by the maximum grade and

minimum radius encountered and this yielded the classification shown below. Table 3.13.

---

DESIGN STANDARD BY MAXIMUM GRADE

<u>Design Standard</u>	<u>Max Grade</u>	<u>Minimum Radius</u>
High	0 - 4%	>100'
Medium	4 - 8%	75' - 100'
Low	8 - 12%	50' - 75'
Extreme	>12%	≤50'

TABLE 3.13

---

### 3.7.7 Statistical testing

It should be noted that the following assumptions have been made to enable statistical testing.

- 1) Samples are normally distributed--(the values of skewness and kurtosis support this in most cases.)
- 2) Variances can be pooled using Fisher's pooled sum of squares (F tests performed substantiated this in most cases).

A more accurate test method would have been to perform analysis of variance tests. However, because of the small data base and the fact that the statistical testing was being used only as a check on existing practice, the more simple test was adopted based on the preceding assumptions.

T-STATISTICS WITHIN GROUP VARIATIONS (Mountain)

<u>Parameter</u>	<u>MT1:MT2 (high)</u>	<u>MT1:MT2 (med)</u>	<u>MT1:MT2 (low)</u>	<u>MT1:MT4 (med)</u>	<u>MT2:MT4</u>
Dist ratio	1.176	.028	.797	.045	.060
° of curv/km direct	1.319	.204	.018	.357	.485
° of curv/km route	1.27	.128	.203	1.23	.667
Rise & Fall/km direct	1.46	.337	.554	.245	.195
Rise & Fall/km route	1.62	.533	.133	.389	.306

TABLE 3.14

NB An approximation is t-statistics greater than 2.0 indicate a statistically significant difference between categories.

T-STATISTICS BETWEEN TERRAIN CATEGORIES SAME DESIGN STANDARD

TERRAIN DESIGN STANDARD

<u>Parameter</u>	<u>MT-SH (high)</u>	<u>SH-RH (high)</u>	<u>RH-F* (high)</u>	<u>MT-SH (med)</u>	<u>SH-RH (med)</u>	<u>RH-F* (med)</u>	<u>MT-SH (low)</u>	<u>SH-RH (low)</u>	<u>RH-F* (low)</u>
Dist Ratio	.001	.406	3.730	3.182	.363	3.030	2.926	1.158	5.785
° of Curv/km direct	.225	1.005	3.143	3.451	.765	5.380	1.763	3.056	6.458
° of Curv/km route	.415	1.921	3.145	3.113	.820	5.648	1.987	0.978	7.113
Rise & Fall/km direct	.290	1.141	5.415	4.089	1.225	7.162	3.356	1.736	3.43
Rise & Fall/km route	.100	1.022	6.240	3.570	1.196	7.362	2.215	1.235	3.287

TABLE 3.15

\*For flat zero values were assumed

T-STATISTICS BETWEEN DESIGN STANDARDS

TERRAIN DESIGN STANDARD

<u>Parameter</u>	<u>MT</u> <u>(HIGH-MED)</u>	<u>MT</u> <u>(MED-LOW)</u>	<u>SH</u> <u>(HIGH-MED)</u>	<u>SH</u> <u>(MED-LOW)</u>	<u>RH</u> <u>(HIGH-MED)</u>	<u>RH</u> <u>(MED-LOW)</u>
Dist Ratio	2.176	1.015	.423	2.193	.336	.298
° of Curv/km Direct	2.393	.735	.670	3.524	.239	1.438
° of Curv/km Route	2.021	1.222	.618	3.170	.302	1.376
Rise & Fall/km Direct	2.678	.969	.431	2.214	.364	.490
Rise & Fall/km Route	1.989	.581	.285	1.388	.512	.336

TABLE 3.16

### 3.7.8 Results

Although there were not enough observations in all sub-categories to enable complete testing, it was apparent that all subcategories could be combined, as t-statistics on the difference of means were not significant at the 5% level (i.e. there was no statistical significance between the various subcategories). Table 3.14 gives some typical results.

Using the observations grouped into the following categories, mountainous, steep hills, rolling hills, flat, again the difference of means was tested using the t-test. (Table 3.15.) For the high design standard parameters the first three categories differed from flat but they showed no statistically significant difference from each other. When the medium design standard parameters were used there was no statistical significance between the steep hills and rolling hills groupings but all other categories were statistically different. For the low design standard parameters again the difference between steep and rolling hills was only marginal.

Then, the differences in parameters for each design standard were tested for each terrain category. In mountainous terrain the differences between high and medium design standard parameters were significant but the difference between medium and low were not. The reverse was true for terrain denoted as steep hills. In rolling terrain there was no statistical difference in design standard parameters and it was assumed that this is also the case if the terrain is flat.

For the second approach the terrain classification was reduced to the major categories as before, i.e. mountainous, steep hills, rolling hills,

T-STATISTICS BETWEEN MAJOR TERRAIN GROUPINGS FOR EACH DESIGN STANDARD

TERRAIN DESIGN STANDARD

<u>Parameter</u>	MT-SH (high)	SH-RH (high)	RH-F (high)	MT-SH (med)	SH-RH (med)	RH-F (med)	MT-SH (low)	SH-RH (low)	RH-F (low)	MT-SH (ext)	SH-RH (ext)	RH-F (ext)
Dist Ratio	1.259	.167	3.555	1.238	.637	2.839	8.285	.064	5.266	2.475	1.051	2.008
° Curv/km Direct	.739	1.284	3.102	1.259	.676	3.548	2.867	1.084	8.968	.553	2.436	8.412
° Curv/km Route	.631	1.475	3.102	1.179	.869	4.186	2.051	1.210	10.208	.234	3.130	8.829
Rise & Fall/km Dir.	2.009	1.315	3.414	1.360	.722	6.495	3.468	.618	5.226	2.178	2.467	4.123
Rise & Fall/km Rte.	2.625	1.479	3.748	1.119	.567	7.431	2.271	.523	4.932	.562	1.991	4.090

TABLE 3.17



T-STATISTICS BETWEEN DESIGN STANDARDS FOR EACH TERRAIN TYPE

TERRAIN DESIGN STANDARD

<u>Parameter</u>	<u>MT</u>	<u>MT</u>	<u>MT</u>	<u>SH</u>	<u>SH</u>	<u>SH</u>	<u>RH</u>	<u>RH</u>	<u>RH</u>
	<u>HI-MED</u>	<u>HI-LO</u>	<u>LO-EXT</u>	<u>HI-MED</u>	<u>MED-LO</u>	<u>LO-EXT</u>	<u>HI-MED</u>	<u>MED-LO</u>	<u>LO-EXT</u>
Dist Ratio	1.170	2.217	1.831	.789	2.009	2.247	.369	1.181	.350
° of Curv/km Direct	2.484	2.746	2.485	.351	2.115	2.132	1.690	3.816	.030
° of Curv/km Route	2.717	2.593	1.995	.500	2.259	2.901	2.961	4.489	.523
Rise & Fall/km Dir.	2.257	3.034	3.863	2.396	3.964	1.579	2.736	1.708	3.960
Rise & Fall/km Rte.	2.582	3.328	4.272	2.617	3.392	1.254	3.225	1.576	3.248

TABLE 3.18

flat.

The t-statistics for the difference of means for the design parameters for each terrain type are given in Table 3.17. For all design standards there was a significant difference between the rolling hills and flat classifications. (NB. The design parameters were assumed to be as low as possible for flat terrain). For the low and extreme design standards there were some statistical difference between terrain groupings, however for the high and medium design standards the design parameters were not sensitive to terrain. An explanation for this is that high design standards pay less attention to the terrain and generally cuts and fills are more severe. Thus the categories were maintained as it was felt that there would be marked differences in earthworks between the terrain groups.

The t-statistics for each design parameter, for each design standard, are given in Table 3.18. As could be expected since we are grouping by maximum grade nearly all categories exhibit some statistical significance at the 5% level.

### 3.7.9 Conclusions

- 1) There is a rational statistical basis for the generally accepted engineering terrain classifications, namely mountainous, steep hills, rolling hills and flat terrain.
- 2) There is also a firm statistical basis for considering the various design standards and the impacts on them by each terrain type.
- 3) The mean values of design parameters and their standard deviations for the various design standards and terrain types are given in Table 3.19.
- 4) Groupings for design standard on the basis of maximum observed

TABLE 3.19  
DESIGN INPUT PARAMETERS FOR VARIOUS TERRAIN

Parameter	TERRAIN DESIGN STANDARD											
	MT (high)	MT (med)	MT (low)	MT (ext)	SH (high)	SH (med)	SH (low)	SH (ext)	RH (high)	RH (med)	RH (low)	RH (ext)
Dist Ratio												
Mean	105	125	155	185	105	115	125	150	105	110	120	130
S.D.	(107) 7	(124) 31	(155) 50	(184) 68	(120) 18	(111) 10	(123) 14	(147) 36	(118) 10	(115) 16	(123) 13	(129) 28
°/km Direct												
Mean	60	200	410	640	90	100	220	550	70	70	180	190
S.D.	(56) 41	(197) 182	(412) 260	(642) 424	(88) 64	(107) 121	(227) 110	(550) 554	(174) 112	(73) 62	(184) 58	(185) 44
°/km Route												
Mean	50	140	250	320	70	90	180	340	60	60	150	160
S.D.	(52) 35	(144) 107	(251) 119	(324) 149	(69) (90)	(90) 89	(181) 75	(337) 200	(143) 87	(58) 42	(149) 41	(161) 36
R&F/km Direct												
Mean	10	40	80	140	10	20	50	80	10	30	40	40
S.D.	(13) 6	(37) 34	(76) 37	(135) 75	(7) 4	(21)	(46) 14	(80) 11	(13) 80	(26) 8	(41) 12	(26) 22
R&F/km Route												
Mean	10	30	50	70	10	20	40	60	10	20	30	30
S.D.	(12) 5	(27) 18	(48) 15	(74) 31	(6) 3	(19) 12	(38) 10	(62) 73	(11) 6	(22) 9	(34) 19	(22) 11
Number of Observs.	9	11	22	33	3	7	11	14	4	9	8	4

Note: Figures in brackets are observed values. The other values given for the mean is the suggested value when appropriate weight is given to the number of observations in each subset.

grade appeared to give better categories than grouping on the basis of<sup>84</sup> surface type.

### 3.8 EARTHWORKS QUANTITIES

#### 3.8.1 Introduction

In the previous section an attempt was made to relate various design parameters to terrain type to enable rapid synthesis of data for prefeasibility studies. This section has similar aims with respect to earthwork quantities.

#### 3.8.2 Methodology

The methodology was to synthesize the results from the following sources:

- 1) Table "look ups"
- 2) Published models, with the terrain parameters from the earlier report as input where applicable.

These results were then pooled and a table "look up" produced.

#### Tables

##### IBRD [12]

This is a simple table which takes no account of design standards.  
See Table 3.20

#### EARTHWORKS VS. TERRAIN (IBRD)

	<u>TERRAIN</u>	
<u>Flat</u>	<u>Rolling</u>	<u>Hilly</u>
5000 m <sup>3</sup> /km	9800 m <sup>3</sup> /km	14,250 m <sup>3</sup> /km

TABLE 3.20

---

US Forest Service [8]

The values in this table are for a 20 foot wide formation and therefore can be regarded as for a low standard two lane road. In the original table the percentage sideslopes are given and they have been translated into terrain types to yield Table 3.21 below.

EARTHWORKS VS. TERRAIN (US. FOREST SERVICE)

<u>TERRAIN</u>		
<u>Flat (10%)</u>	<u>Rolling (50%)</u>	<u>Mountainous (100%)</u>
710 m <sup>3</sup> /km	6900 m <sup>3</sup> /km	51,300 m <sup>3</sup> /km

TABLE 3.21US Bureau of Public Roads [8]

The quantities were given as typical for 2-lane rural roads and they could be considered as for medium design standards roads.

EARTHWORKS VS. TERRAIN (US BPR)

<u>TERRAIN</u>		
<u>Flat</u>	<u>Rolling</u>	<u>Mountainous</u>
9500 m <sup>3</sup> /km	19,000 m <sup>3</sup> /km	38,000 m <sup>3</sup> /km

TABLE 3.22US Interstate Standards [8]

These quantities are again from the Bureau of Public Roads records

for various States and they can be regarded as typical for very high standard roads.

EARTHWORKS VS. TERRAIN (US. INTERSTATE)

<u>TERRAIN</u>		
<u>Flat</u>	<u>Rolling</u>	<u>Mountainous</u>
14,000 m <sup>3</sup> /km	33,250 m <sup>3</sup> /km	109,000 m <sup>3</sup> /km

TABLE 3.23

Vance [24]

In his thesis Vance gives a more comprehensive table; parts of which are reproduced in Table 3.24 below.

EARTHWORKS VS. TERRAIN (VANCE)

<u>Terrain</u>	<u>DESIGN STANDARD</u>		
	<u>Low</u>	<u>Medium</u>	<u>High</u>
Flat	1,300	5,220	19,000
Rolling	2,400	9,500	47,500
Mountainous	7,130	23,800	190,000

TABLE 3.24

NB Quantities are in cubic meters per kilometer

Ethiopian

The following table comes from discussions held with Ethiopian

highway engineers by project staff from MIT, 1976.

---

EARTHWORKS VS. TERRAIN ( ETHIOPIA)

DESIGN STANDARD

<u>Terrain</u>	<u>Penetration &amp; Feeder</u>	<u>Low Volume</u>	<u>High Volume</u>
Flat	<1,500	<5,000	<12,000
Rolling	1,500-5,000	5,000-10,000	12,000-18,000
Hilly	5,000-10,000	10,000-15,000	18,000-25,000
Mountainous	10,000	>15,000	>25,000

TABLE 3.25

---

Model

Australian Model [14]

This model simply gives a height, which varies with terrain, which is then substituted into the following formula to yield the desired quantities.

$$Q = 16.3[(12H-3)(FW + 0.75 + 3H)]$$

Q...quantity in cubic yards/mile

FW...formation width of road

H...height of fill.

One should bear in mind that Australia is a very flat country and so the hilly and mountainous categories will underestimate those for more rugged topography. The quantities given by this model are shown in Table 3.26.

---

EARTHWORKS VS. TERRAIN (AUST. MODEL)
DESIGN STANDARD

<u>Terrain</u>	<u>Low (24' width)</u>	<u>Medium (32' width)</u>	<u>High (44' width)</u>
Flat	1,934	2,492	3,328
Rolling	5,000	6,302	8,253
Hilly	12,807	15,595	19,777
Mountainous	35,111	40,874	49,516

TABLE 3.26

---

NB. Quantities are in cubic meters per kilometer

Soberman [23]

Soberman performed a regression analysis to obtain cost for various design standards in flat and mountainous terrain.

The equations are

$$C_L = 5720W + 3830V - 123,000$$

$$C_M = 57,900W + 5860V - 490,000$$

Where  $C_L$ ,  $C_M$  are the cost per km in bolivars for flat and mountainous terrain respectively

W.....design width in meters (high = 14.6, med = 10.3, low = 7.2)

V.....design speed in km/hr (high = 80, med = 60, low = 50)

Conversions

\$1.00 US = 4.48 bolivars--(page 43 Soberman)

1961 \$1.00 US = 1.92 m<sup>3</sup>--(Price trends for Federal Aid construction USA)



Relative percentage of earthworks in total cost--(Soberman, page 45)

37.2% flat terrain

48.6% mountainous terrain

After these conversions results are as shown in Table 3.27

---

EARTHWORKS VS. TERRAIN (SOBERMAN MODEL)

<u>Terrain</u>	<u>DESIGN STANDARD</u>		
	<u>High</u>	<u>Medium</u>	<u>Low</u>
Rolling Hills	42,621	26,462	17,515
Mountainous	194,814	95,541	45,871

TABLE 3.27

Quantities are in cubic meters per kilometer

---

Lago [15]

Lago also developed a series of regression models for various terrain types as listed below.

Mountainous (average grades >5%)

$$EX = -8236 + 7719RW$$

Rolling Terrain (average grades 1 - 5%)

$$EX = -5,429 + 3,497 RW$$

Flat

(a) No flood problems  $\log EX = 6.5459 + 1.06 \log RW$

(b) Subject to light flooding  $EX = 83.5548 + 1290 RW$

Substitution of the road widths associated with each design standard yields the results given in Table 3.28

---

EARTHWORKS VS. TERRAIN (LAGO MODEL)

DESIGN STANDARD

Terrain

	<u>Low</u>	<u>Medium</u>	<u>High</u>
Flat (no floods)	5,644	7,742	10,903
Flat (light floods)	9,371	12,596	17,369
Rolling	19,749	28,492	41,431
Mountainous	47,341	66,638	95,198

TABLE 3.28

NB. Quantities in cubic meters per kilometer.

---

### 3.8.3 Conclusions

From the foregoing tables it can be seen that there are problems with interpretation of design standards and terrain types. For example, the Ethiopian high standard corresponds almost to the USA medium standard road and the Australian mountainous terrain corresponds to the steep hills category used in this report.

For the purposes of this report the categories of terrain classification are defined as follows.

Flat: Dominant horizontal dimension with little or no variation in the ground plane; little or no relief with many marshes.

Rolling Hills: Rounded hills with an apparent horizontal dimension,

ranging in height from 200 to 800 feet, low to moderate slopes and rolling profile.

Steep Hills: High hills rising steeply from the base plane, ranging in height from 800 to 2000 feet above the adjacent base plane, usually with a strong vertical dimension and a rounded profile.

Mountainous: Dominant vertical dimension; at least 2000 feet of relative elevation between the valley floor and ridge line or peak with jagged or pointed profile.

The design standards typical of each category are given in Table 3.29

ADOPTED DESIGN STANDARDS FOR EACH TERRAIN TYPE

	<u>DESIGN STANDARDS</u>			
	Width	Max Grade	Design Speed	Min Radius
Extreme	20' (6)	>12%	<20 (30)	<100 (30)
Low	24' (7.3)	8-12%	30 (50)	200 (60)
Medium	32' (9.8)	4-8%	50 (80)	250' (75)
High	44' (13.4)	<3%	>60 (100)	600' (180)
USA High	>44' (>13.4)	<3%	>70 (110)	1300' (400)

TABLE 3.29

( ) metric equivalents

With these classifications and the preceding tables the following quantities were considered typical See Table 3.30

---

ADOPTED EARTHWORKS FOR DESIGN STANDARD VS. TERRAIN

DESIGN STANDARD

Terrain

	<u>Extreme</u>	<u>Low</u>	<u>Medium</u>	<u>High</u>	<u>USA High</u>
Flat	<1,000	1,200	5,000	12,000	15,000
Rolling Hills	2,000	5,000	10,000	20,000	40,000
Steep Hills	5,000	10,000	20,000	50,000	150,000
Mountainous	8,000	20,000	40,000	100,000	200,000

TABLE 3.30

NB. Units are m<sup>3</sup>/km

---

3.9 VEHICLE OPERATING COSTS (ETHIOPIAN CTS./KM.)

3.9.1 Introduction

Vehicle operating costs for common vehicle types were calculated for, the range of terrain classifications, design standards, and for varying levels of maintenance. The parameters, rise and fall per kilometer and degree of curvature per kilometer, typical of each terrain classification and design standard were input. See Table 3.31. These values were established by the analysis outlined in the preceding section.

---

 INPUT PARAMETERS FOR VEHICLE OPERATION COSTS VS. TERRAIN

TERRAIN

<u>Design Standard</u>	<u>Mountains</u>				<u>Steep Hills</u>				<u>Rolling Hills</u>			<u>Flat</u>
	High	Med	Low	Ext.	High	Med	Low	Ext.	High	Med	Low	All
°/Km	50	140	250	320	70	90	180	340	60	60	150	0
Rise and Fall m/Km	10	30	50	70	10	20	40	60	10	20	30	0

TABLE 3.31

---

3.9.2 Terrain Classification

For the purpose of this section, the categories of terrain classification are as defined previously. viz.

Flat - Dominant horizontal dimension with little or no variation in the ground plane; little or no relief with many marshes.

Rolling Hills - Rounded hills with an apparent horizontal dimension, ranging in height from 200 to 800 feet, low to moderate slopes and rolling profile.

Steep Hills - High hills rising steeply from the base plane, ranging in height from 800 to 2000 feet above the adjacent base plane, usually with a strong vertical dimension and a rounded profile.

Mountainous - Dominant vertical dimension; at least 2000 feet of relative elevation between the valley floor and ridge line or peak with jagged or pointed profile.

3.9.3 Design Standards

The design standards typical of each category are as given in Table 3.29.

3.9.4 Maintenance Level

It was postulated that the level of maintenance would be reflected in the surface condition. The following values were input. See Table 3.32.

		<u>Roughness</u>	<u>Rut Depth (mm)</u>
<u>Paved</u>	High	2250	-
	Med	3000	-
	Low	4000	-
	None	5000	-
<u>Gravel</u>	High	3000	20
	Med	5500	40
	Low	9000	60
	None	13000	80
<u>Earth</u>	High	3750	20
	Med	6500	40
	Low	11000	80
	None	16000	125

TABLE 3.32

### 3.9.5 Results

The results are shown graphically. A typical figure is shown Figure (3.11) and further figures are included in Appendix B. [Warning: in some cases the input parameters exceed the safe limits specified for the T.R.R.L. equations and the figures should be viewed cautiously in these cases. Further, the abscissa scale is nonlinear and so the shape

of the curves may be slightly misconstrued].

95.

### 3.9.6 Conclusions

- 1) It is not reasonable to input values outside the safe range as specified by T.R.R.L. as inconsistencies appear (e.g. Kink in Fig. 3.11 for earth roads.)
- 2) The operating costs of passenger cars are rather insensitive to terrain type, surface type and design standard. Therefore, for low volume roads which are predominantly used by passenger cars earth or gravel roads should prove satisfactory.
- 3) The inclusion of value of time makes operating costs more sensitive to changes in terrain, design standard and surface type (e.g. the difference for trucks and buses is marked whereas it is only minimal for passenger cars.) Therefore if the project is small, and the subsequent saving in time is small, such that it does not lead to extra utilization, then the V.O.C. savings predicted for an upgrading will be overestimated.
- 4) Maintenance becomes less important as design standards become lower and terrain becomes rougher, as speed is controlled by alignment and not surface condition. Therefore, maintenance standards commensurate with design standards seem most reasonable.
- 5) VOC's increase by 1/3 between paved and unpaved when both are subject to medium maintenance. Note, that for the same traffic the unpaved surface will be more expensive to maintain, and that medium maintenance implies different activities for the different surface types.
- 6) VOC's increase by 1/2 between paved and unpaved when both are subject to low maintenance.

Terrain - Mountainous  
Design Standard - Extreme

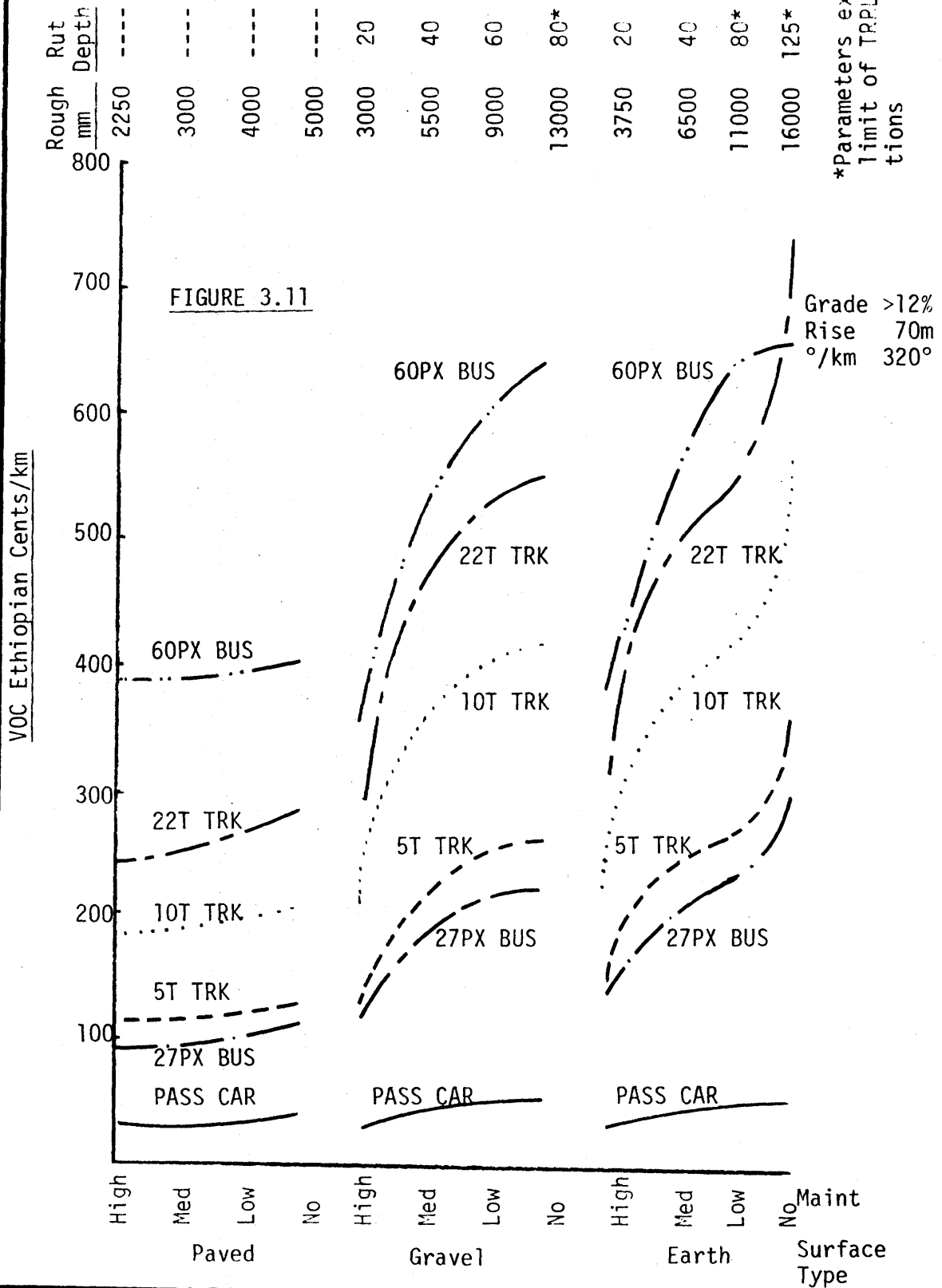



- 7) At intensive levels of maintenance the VOC's are practically the same for all surface types. Thus if traffic volumes are low and intensive maintenance is practiced, earth roads are a viable alternative. This fact is borne out by the fact that many haul roads on construction sites, where the maintenance of haul roads only incurs a marginal expense, as equipment is readily available, are earth.
- 8) No conclusion can be drawn for the no maintenance case as a paved road may deteriorate to a gravel surface, and gravel surface to an earth surface and hence the original investment in surfacing is lost.
- 9) VOC's rise about 5% for each decreasing level of maintenance for a paved surface, whereas the increase is between 30% and 50% for unpaved surfaces.
- 10) Ton-kilometre costs are lower for large trucks.

## CHAPTER 4

### MAINTENANCE MANAGEMENT

#### 4.1 OVERVIEW

In the following chapter the influence of maintenance on user costs and design are explored from the aspect of maintenance management. In the context of this thesis, management is taken to be the level of maintenance effort as determined by management and not the actual managerial structure.

Firstly, unpaved roads are investigated and as the grading operation is the critical maintenance operation which can reduce vehicle operating costs, it is investigated in detail and some optimal grading frequencies suggested.

The second section is devoted to maintenance of paved roads. Again the interest lies in reducing vehicle operating costs by means of surface maintenance. In this case, unlike unpaved roads, the pavement condition depends upon many maintenance operations and their effects on reducing the impacts of traffic and environment. The traffic impacts have been established by AASHO and TRRL studies which were used in the formulation of the HCM, (Refs. 10, 11, 17), however the environmental impacts had to be established. The chief environmental agent is water, and the effects of moisture penetration are outlined in Appendix F and this formed the basis for the work outlined in this section.

## 4.2 MAINTENANCE OF UNPAVED ROADS

### 4.2.1 Introduction

For the maintenance engineer the blading of an unpaved road has many aspects. Firstly, there is the trade-off between power graders, drawn graders and labor intensive methods; then there is the option of blading only when the moisture content of the surface is the optimum for compaction so that the best possible surface is obtained after blading. In dry climates this may mean that a water truck and roller are used in conjunction with the grader making the operation physically more efficient but financially more expensive for the maintenance authority. Still another concern is that the operator, (if the decision is to use a grader), should be using the equipment efficiently. The following are some points the maintenance engineer should watch to insure maximum job efficiency.

- 1) The blade is set at the correct angle for the operation being performed. For example, for cutting the cutting edge should lead into the ground, for planing the blade should be vertical, whereas for dragging the cutting edge should lag behind the mold-board.
- 2) The window should not fall under the rear wheels of the grader as this will result in a wavy surface and also the wheels cannot get proper traction.
- 3) The maintenance operation should be performed in the least possible number of passes.
- 4) The surface should be cut to the bottom of all holes and corrugations.
- 5) The material should be kept on the roadway and not spilled into drains.

- 6) The speed should not be too fast causing grader to bounce as this will result in corrugations.
- 7) The speed should be as high as possible consistent with the above, operator's skill and grader power.

From the foregoing it can be seen that the major objective of the maintenance engineer is to perform the maintenance operation as efficiently as possible, striving with the constraints of available materials, labor, and capital to reach the production possibility frontier.

The situation can be illustrated diagrammatically. See Figure 4.1.

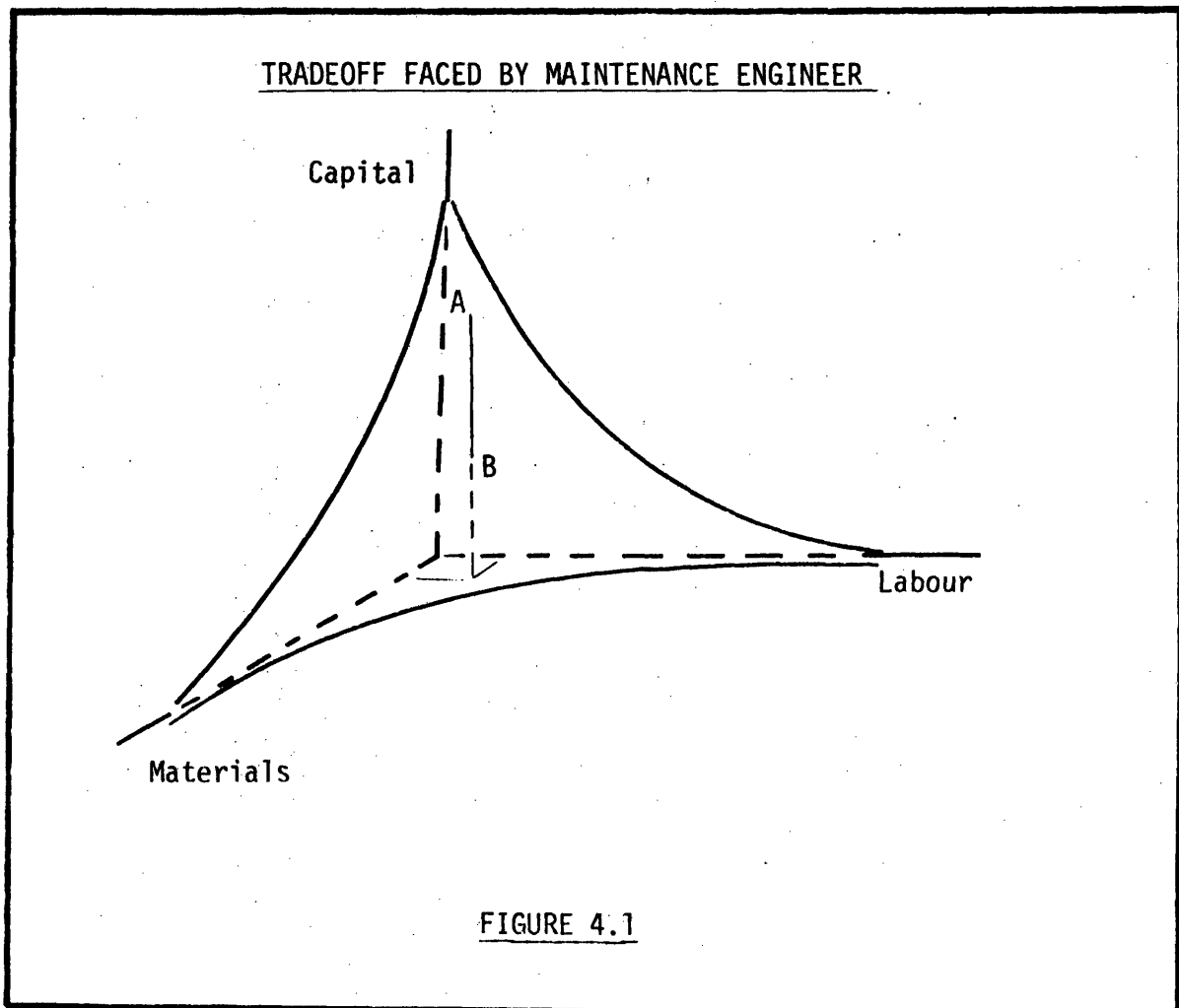

The engineer seeks to be on the surface at B, for example, rather than some less efficient exterior point, say A.

The engineering planner places a different emphasis on the maintenance of unpaved roads. The question which he asks is: given the operation will be performed efficiently, how often should it be performed to provide the optimal total transportation cost? The answer to this question provides the information required for budget allocation, and also estimates of maintenance costs for route evaluation studies. The solution to the problem is shown graphically in Figure 4.2. As grading frequency increases the cost of maintenance increases, but the vehicle operating costs decrease as the road surface becomes smoother.

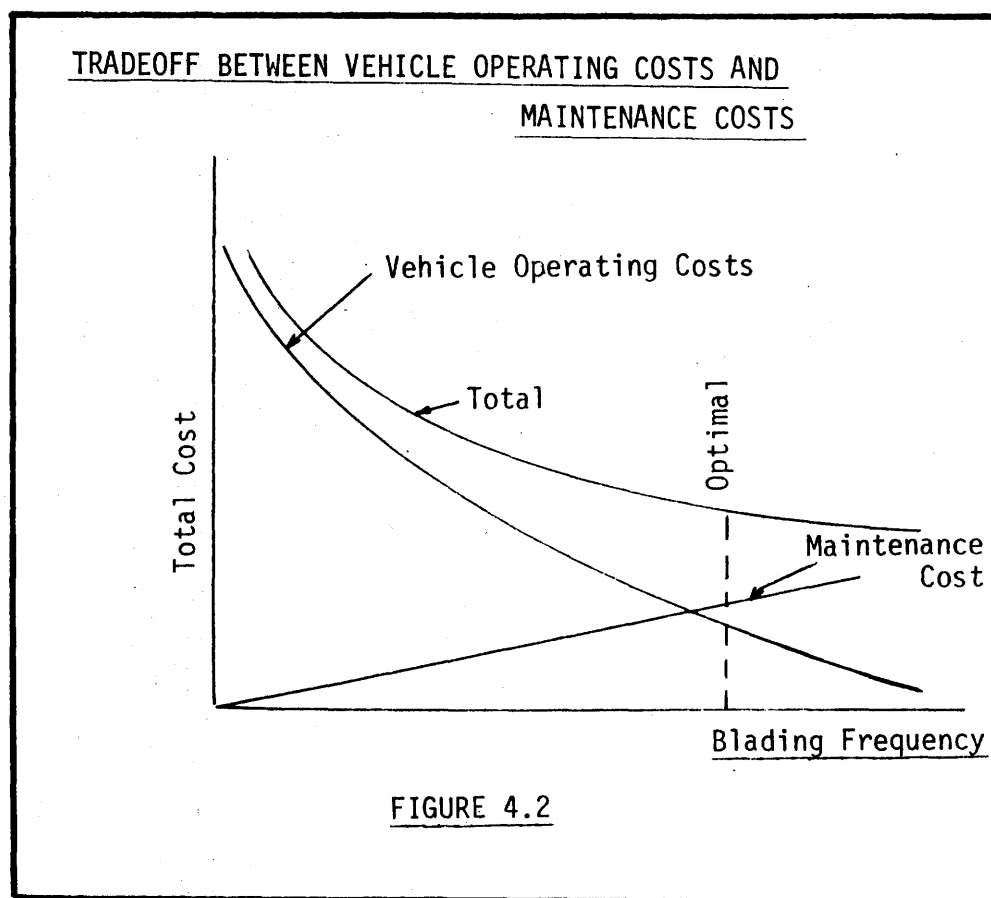

It should be noted that both problems are strongly linked as the budget allocated by the planner imposes constraints on the maintenance staff and conversely any change in efficiency in the maintenance operation will impact the planner's decision as shown in Figure 4.3.

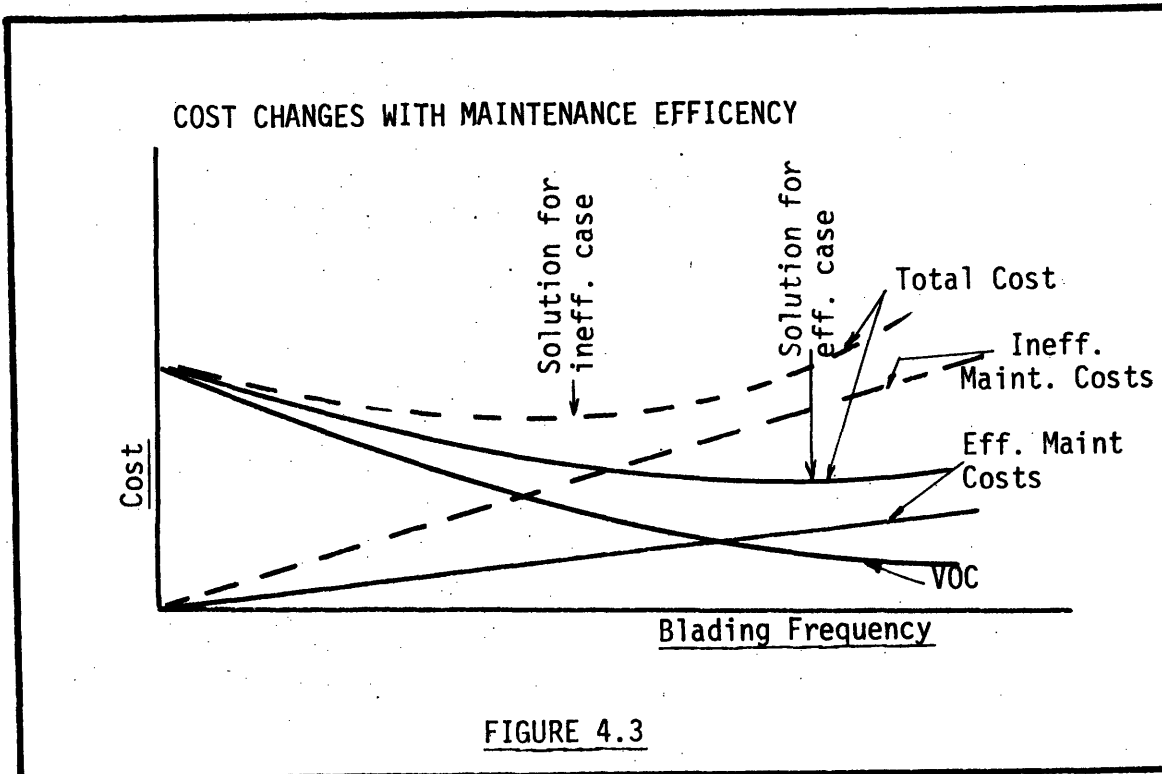

For the purposes of this paper the efficiency of the operation will not be questioned and the aim will be to establish guidelines for blading frequency for planning purposes with efficiencies as calculated by consultants in the various countries (Details in Appendices A and C).

#### 4.2.2 Methodology

In order to establish some general rules for grading frequency many hypothetical case studies were investigated. Four countries in Africa were studied to see if there was any international variation. The five surface

types for which TRRL established deterioration relationships in Kenya were used, namely coral, quartzitic, volcanic, and lateritic gravels and earth surfaces. Grading policies of once per week, once per two weeks, once per month, and per four months and once per year were investigated for various traffic volumes.

From the grading frequency it was possible to determine the annual grading cost using the cost and productivity data in Appendix C.

From the grading frequency for various ADT the number of vehicles between each blading could be computed. Half this number was substituted into the TRRL equations to obtain the average roughness, average rut depth and average surface looseness. (Note the volume is again halved in the equation to allow for two-way traffic). These surface condition values were then substituted into the vehicle operating cost equations and costs per kilometer obtained.

Using traffic compositions typical for the country in question, the operating cost for each ADT could be found. The traffic compositions were subject to sensitivity testing by arbitrarily adding 5% more to each truck category from the passenger car group and vice-versa.

Figure 4.4 shows the tree used in the generation of the case studies.

The increase in vehicle operating, over what would be incurred on the smoothest possible surface, were plotted against grading costs. See Figure 4.5 for typical shape, others are included in Appendix E. It was then postulated that an expenditure incurred by grading should return an equal savings in vehicle operating costs, recognizing this may not be the case if the planner wishes to have the private sector bear a larger portion of the costs in the transportation field.

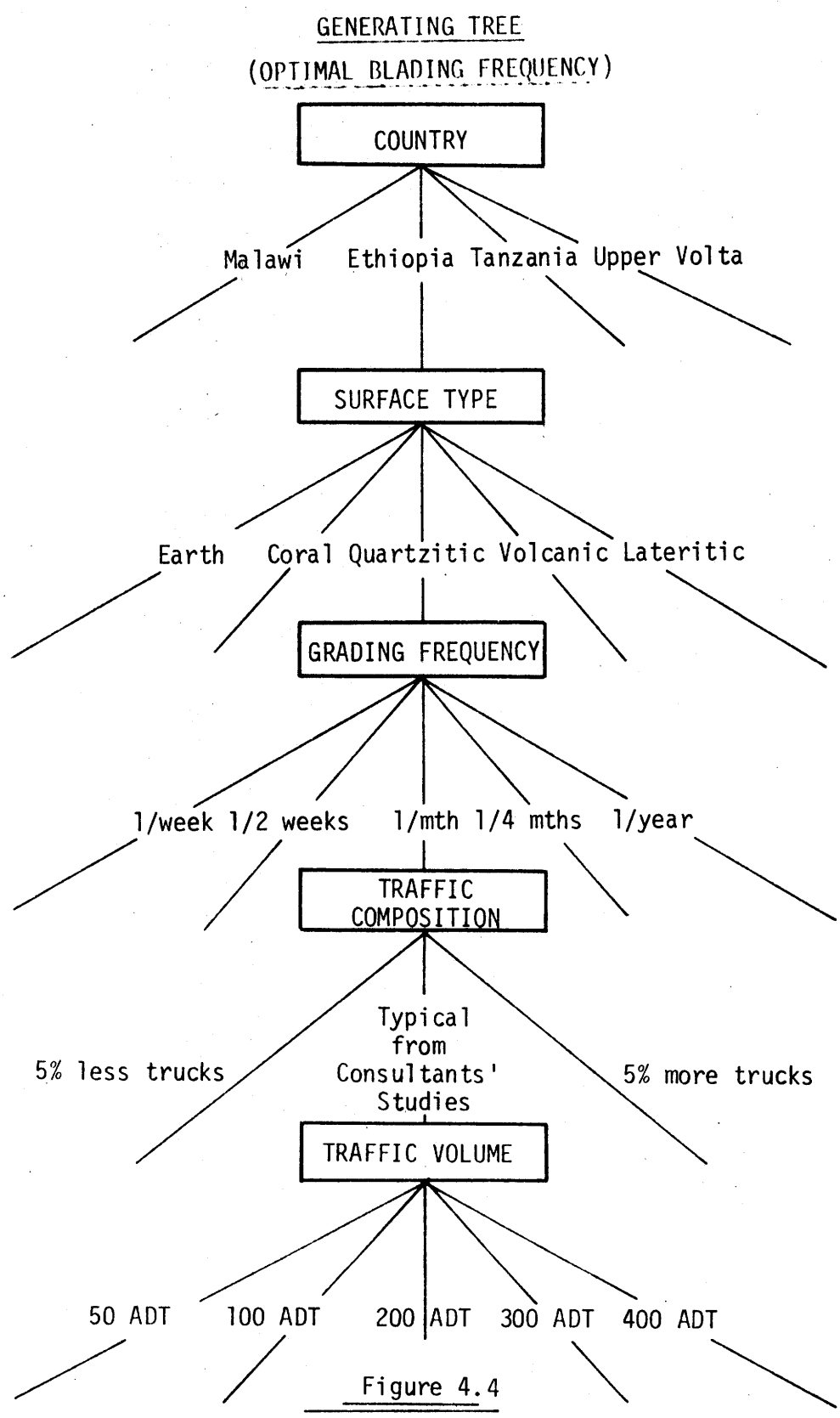

Figure 4.4



Tradeoff Between VOC and Grading Costs

Lateritic Gravel

Ethiopia

Typical Traffic Composition

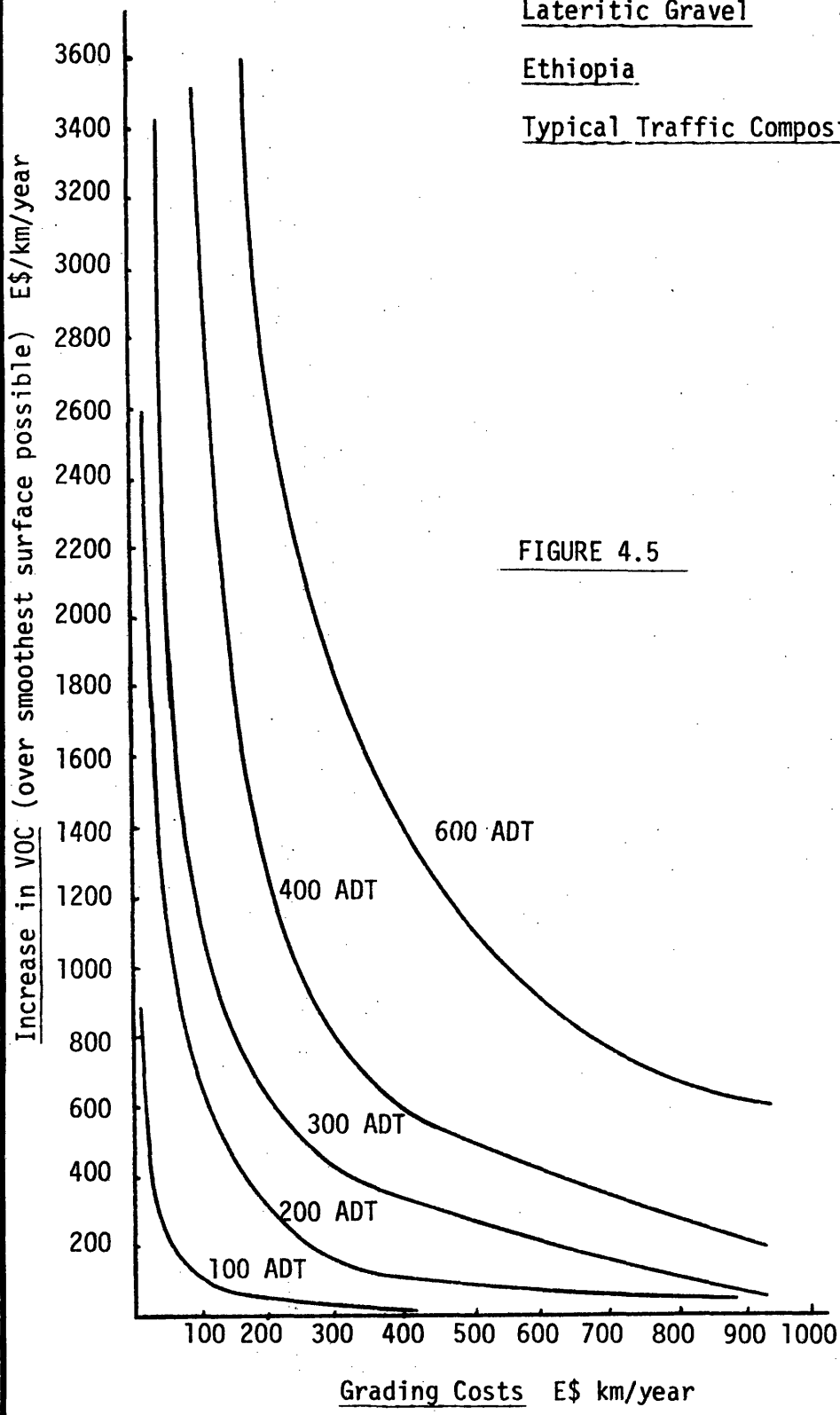

FIGURE 4.5

#### 4.2.3 Results

From the points of tangency of the graphs for each ADT the average number of passes between bladings was obtained and the results are tabulated in Table 4.1.

#### 4.2.4 Conclusions

- 1) Coral gravel roads provide the best solution from the blading aspect as they require less frequent grading than other unpaved surfaces. Quartzitic and volcanic gravels are marginally better than lateritic gravels and of course earth surfaces require much more frequent bladings. The gravel used for a particular road is usually determined by material availability but if coral gravel is available then it should be used.
- 2) Shadow prices and maintenance costs vary across nations making it impossible to establish a universal rule for blading frequency. However, ignoring Malawi where the standing costs for light vehicles were constrained to zero, the optimum blading frequency, for gravel lies between 4000 and 7000 vehicle passes between bladings, and for earth lies between 1000 and 2500 vehicle passes between bladings. This means that an earth road typically carrying 50 ADT should be bladed approximately once per month as should a gravel road carrying 200 ADT.
- 3) The smaller the percentage of trucks present in the traffic composition then the less frequent the blading should be, conversely if there is a larger percentage of trucks present than usual then the number of bladings per year should be increased.

- 4) If value of time is included then the blading frequency would have been increased.
- 5) If the men and equipment utilized in the grading operation have a shadow price greater than unity then the blading frequency should be decreased.
- 6) It should also be noted that road design standards will impact on maintenance policies. For example if the speed is limited by alignment then an increase in roughness will have minimal impact on vehicle operating costs.
- 7) It has been demonstrated that it is possible via the equations imbedded in the HCM to determine the optimal blading frequency for various surfaces.

NUMBER OF VEHICLES BETWEEN BLADINGS (two-way)

SURFACE	TRAFFIC					
	Type	Composition	Ethiopia	Tanzania	Malawi	Up. Volta
<u>Coral</u>						
	Typical		6600	7640	11890	4020
	More Trucks		5540	7180	10470	3710
	Less Trucks		7050	9310	19350	4300
<u>Lateritic</u>						
	Typical		5260	6120	8860	3700
	More Trucks		4550	5890	7260	3380
	Less Trucks		5680	7500	11300	4100
<u>Quartzitic</u>						
<u>and</u>						
<u>Volcanic</u>						
	Typical		5400	6300	8920	3905
	More Trucks		5160	5710	7920	3120
	Less Trucks		5800	7260	11500	4160
<u>Earth</u>						
	Typical		1640	2540	2160	1060
	More Trucks		1530	2400	1950	930
	Less Trucks		1650	2960	2780	1354

TABLE 4.1

### 4.3 OPTIMAL MAINTENANCE OF PAVED ROADS

#### 4.3.1 Introduction

The maintenance organization for paved surfaces requires more management than that for unpaved surfaces as the maintenance operations are more specialized and more varied. For unpaved surfaces the crucial maintenance operations for surface maintenance were blading and gravel replacement whereas for paved surfaces the policies can include crack sealing, patching, seal coats, level courses, and overlays. The frequency of the above operations depends largely upon pavement strength, traffic volume, and environment, and these effects were investigated as is outlined below.

#### 4.3.2 Methodology

The modifications as outlined in Appendix F, under changes to the regional factor, were incorporated into the structure of the HCM and then some 145 case studies as shown on the generation tree (Figure 4.6) were run. The costs used for these studies are again Ethiopian but similar studies could be run for other countries. It should also be noted that the traffic composition used was that typical for Ethiopia.

#### 4.3.3 Results

Some results are shown graphically in Figure 4.7 where the total discounted costs are plotted against a range of pavement strengths and maintenance policies. The complete set of graphs appear in Appendix G. Details of the maintenance policies appear in Appendix H. Routine maintenance costs have been excluded for simplicity.

GENERATION TREE FOR OPTIMAL MAINTENANCE

POLICY FOR PAVED SURFACES

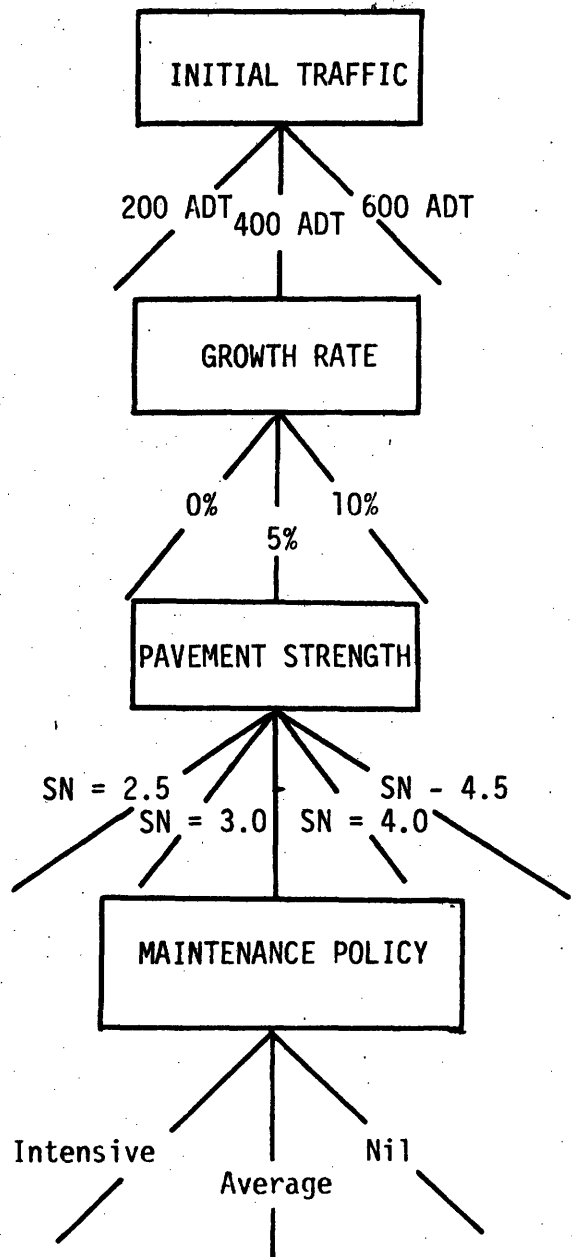



FIGURE 4.6

TOTAL DISCOUNTED COSTS FOR VARIOUS PAVEMENT STRENGTHS AND MAINTENANCE POLICIES

Traffic 200 ADT  
0 % growth

 Vehicle Operating Costs  
 Incremental Const. Costs  
 Maintenance

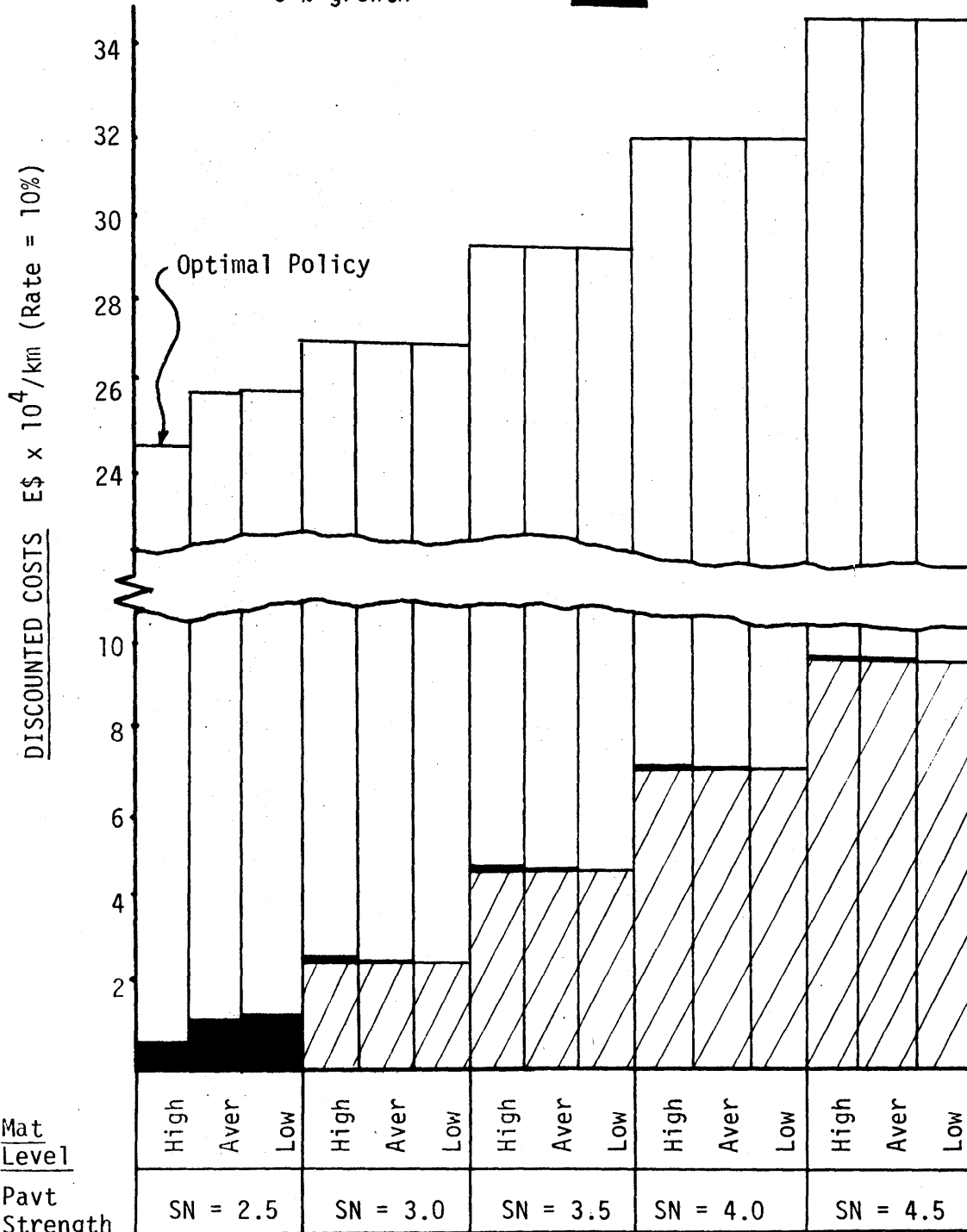

FIGURE 4.7

#### 4.3.4 Conclusions

- 1) The primary conclusion is that intensive maintenance invariably leads to the best policy for a given pavement design; however, the benefits become less as pavement strength increases. It must be borne in mind that the model is now much more sensitive to maintenance activities than previously and this is partially responsible for these results.
- 2) It is worthy of note that for the weak pavement the maintenance costs themselves, as well as the total costs, are lower for the intensive maintenance policy. The reason for this is simply that patching of cracks offsets the need for seal coats and overlays which are much more expensive.
- 3) If a highway department wishes to cut its maintenance budget then an increase in design pavement strength should be considered rather than decreasing maintenance activities.



## Chapter 5

SUMMARY AND RECOMMENDATIONS5.1 SUMMARY

The following is a summary of the findings of this thesis and the reader should consult the appropriate section if more detail is desired.

- 1) The Highway Cost Model alone cannot provide solutions to problems of detailed design but it should be used in conjunction with established design rules.
- 2) The equations within the Highway Cost Model are limited by the range of the variables and extrapolation beyond the ranges can be misleading.
- 3) Operating costs of passenger cars are relatively insensitive to terrain, surface type and design standard and so for roads where passenger cars predominate lower standard roads should suffice.
- 4) The inclusion of value of time makes it more easy to find in favour of high design and surface standards.
- 5) Maintenance effort commensurate with the design standards seem appropriate.
- 6) Vehicle operating costs increase by 33% and 50% between paved and unpaved surfaces when both are subject to medium and low maintenance efforts respectively.
- 7) At intensive levels of maintenance vehicle operating costs are essentially the same for all surface types and so unpaved surfaces are very practical if subject to rigorous upkeep.

- 8) Grade reduction projects generate very little economic saving unless there are large volumes of traffic (ADT > 200), the original grade is steep, (>7%) and the reduction is substantial (>3%) and earthwork quantities are limited.
- 9) For route evaluation usually the most direct route which stays within accepted design standards without extensive earthwork quantities will provide the best solution. The amount of earthworks is a function of the traffic volume and for volumes less than 100 ADT minimum earthworks only should be attempted.
- 10) The Highway Cost Model is sensitive to the following parameters, route length, value of time, pavement strength, number of heavy trucks and discount rate.
- 11) The optimal blading frequency for gravel roads lies in the range of 4000 to 7000 vehicle passes between bladings and for earth roads 1000 to 2500 vehicle passes.
- 12) Intensive maintenance of paved roads invariably leads to the best overall cost.
- 13) Weak pavements can never be made viable even with intensive maintenance and hence it is best to err on the side of over design.
- 14) To cut maintenance expenditure one can either increase pavement thicknesses in design or intensify cracking and patching activities.
- 15) Staging policies which involve changes in surface type of pavement thickening are the most viable.

- 16) The way to generate data using terrain classification is feasible and statistically valid classifications exist to allow unambiguous transfer of data.

## 5.2 RECOMMENDATION FOR FURTHER RESEARCH

It is desirable to simplify the HCM to enable it to be more applicable to network studies, however before these simplifications are attempted further research into the relationships within the model structure should be undertaken. Some of this work is already underway in Brazil under the auspices of the World Bank but further work is required on the deterioration relationships to establish better regional and drainage factors.

REFERENCES

1. AASHO -- "A Policy on Geometric Design of Rural Highways", 1965.
2. Agarwal, S. K., "Highway Design Standards Model: Applications and Findings", IBRD Report Unpublished.
3. Baker et al -- "Handbook of Highway Engineering", Van Nostrand Reinhold Company 1975.
4. Basquaro, L. F., "Road Maintenance Costs in Tanzania", Paper produced 1969.
5. Berger, F., "Evaluation of Alternate Pavement Designs and Traffic Flow Patterns on the Chikwawa-Bangula Road", Malawi Report for U.S. A.I.D., draft 1976.
6. Bhandari, A., Berger, F., "The Highway Cost Model: Evaluation of the Dar-es-Salaam-Morogoro Section of the Tanzania Zambia Highway", Report Unpublished.
7. Country Roads Board, Australia, "Proper and Economical Use of Plant in the Field", November 1968.
8. Daniel, Mann, Johnston and Medenhall, "Technical and Economic Feasibility, Chikwawa-Bangula Road, Malawi", January 1973.
9. Guenther, Karl., unpublished data on excavation quantities collected from BPR State Highway Department, etc., Department of Civil Engineering, M.I.T., Cambridge, MA, 1968.
10. Harris, F., "Ethiopian Road Maintenance Study", June 1973.
11. Hide, H. et al, "The Kenya Road Transport Cost Study: Research on Vehicle Operating Costs" TRRL; Department of the Environment Report No. 672, 1975.

12. Hide, H. et al, "The Kenya Road Transport Cost Study: Research on Road Deterioration", TRRL, Department of the Environment Report No. 673, 1975.

13. IBRD, "Study of the Substitution of Labor for Equipment in Road Construction", Phase I, Final Report, October 1971.

14. International Road Federation, "In-depth Study Reports from the World Survey of Current Research and Development on Roads and Road Transport", June 1973.

15. Lack et al, "A Model for the Economic Evaluation of Rural Roads", Paper Number 488 presented to the Fourth Conference of the Australia Road Research Board Melbourne, 1968.

16. Lago, A. M., "Intercity Highway Transportation Cost Functions in Underdeveloped Countries", Unpublished Ph.D. Dissertation, Harvard University, Cambridge, MA, 1966.

17. Ministry of Transport, "Layout of Roads in Rural Areas", HMSO, London, 1968.

18. Moavenzadeh, F. et al, "The Highway Cost Model: General Framework", TAP Report No. 75-4, M.I.T., Cambridge, MA, September 1975.

19. Obhi, K., "Simulation of Road Construction Maintenance and User Costs on 13.7 km of the Yegeresso-Sarossarosso Section: Bobo Dioulasso-Havnde Road", Upper Volta, IBRD Report Unpublished.

20. O'Flaherty, C.A., "Highway Engineering", Volume 2, 1974.

21. Ortega, N. G., "Economic and Financial Vehicle Operating Costs," Ethiopian Road Authority, February 1976.

22. Robinson, R. et al, "A Road Transport Investment Model for Developing Countries", TRRL, Department of the Environment Report No. 674, 1975.

23. Scott, Wilson, Kilpatric and Partners + Economic Intelligence Unit, "Lilongwe-Michinji-Zambia Border Road Study".

24. Soberman, R.M., Transport Technology for Developing Regions, "A Study of Road Transportation in Venezuela", Cambridge, MA, M.I.T. Press, 1966.

25. Vance, "Cost Functions for Comparison of Low Cost Transportation Technologies", Ph.D. Thesis, 1970, Department of Civil Engineering, University of California.

26. Wyatt, R., Sheffi, Y., "Evaluation of Alternative Design and Maintenance Standards for the Asela-Dodola Road (Ethiopia)", Report for U.S. A.I.D., draft 1976.

APPENDIX A  
COST DATA INPUT  
VEHICLE OPERATING COSTS

ETHIOPIA

Names	<u>PASS CAR</u>		<u>27P BUS</u>		<u>60PX BUS</u>		<u>5T TRK</u>		<u>10T TRK</u>		<u>22T TRK</u>		<u>22T TRK</u>	
Category	1		4		3		4		5		5		5	
Fuel Type	1		2		2		2		2		2		2	
VHP	0		100		150		120		150		150		150	
Speed	102		102		102		102		102		102		102	
Tare Wt.	.8		2.5		5.0		4.0		6.0		16.0		16.0	
Max Load	.5		2.5		5.0		7.1		10.1		22.2		28.4	
Axle Type/	1	.50	1	.40	1	.40	1	.34	1	.26	1	.20	1	.20
	1	.50	1	.60	1	.60	1	.66	1	.74	1	.20	1	.20
	0	0	0	0	0	0	0	0	0	0	2	.27	2	.27
	0	0	0	0	0	0	0	0	0	0	2	.33	2	.33
	0	0	0	0	0	0	0	0	0	0	0	0	0	0
<u>Economic</u>														
Veh Cost	7565.		36215.		113093		27390.		47876.		69575.		69575.	
Tire Cost	55.		106.		407.		228.		407.		407.		407.	
Overhead	0.		0.		0.		0.		0.		0.		0.	
Insurance	0.		0.		0.		0.		0.		0.		0.	
Reg & Lic	0.		0.		0.		0.		0.		0.		0.	
Cargo/VHR	0.		0.		0.		0.		0.		0.		0.	
MNT LAB	2.43		3.58		3.58		3.58		3.58		3.58		3.58	
Driver	0.		156.		429.		242.		304.		634.		634.	
Helper	0.		0.		0.		0.		0.		0.		0.	
POL	.52		.35		1.50									
SOC DISC %	10.		10.		10.		10.		10.		10.		10.	
Parts E/F	.51		.725		.725		.725		.725		.725		.725	
UTILIZATIN														
UTIL hr/yr	265.		768.		691.		768.		768.		844.		844.	
UTIL km/yr	17000		43000		38700		43000		47300		47300		47300	
Life YRS	15		15		15		15		15		15		15	
	6.0		9.0		12.		8.0		11.		10.		10.	



MALAWI  
VEHICLE DESCRIPTION AND COSTS

VEHICLE DESCRIPTIONS

Name	<u>PASS CAR</u>	<u>1.5 TRK</u>	<u>60PX BUS</u>	<u>5T TRK</u>	<u>7T TRK</u>	<u>10T TRK</u>	<u>28T TRK</u>
Category	1	4	5	4	5	5	5
Fuel Type	1	1	2	2	2	2	2
VHP	0.0	80.00	150.00	100.00	120.00	150.00	265.00
Speed	102.00	102.00	102.00	102.00	102.00	102.00	102.00
Tare Wight	0.80	1.00	1.00	2.50	4.00	6.00	18.00
Max Load	0.50	1.50	1.50	5.10	7.10	10.10	28.40
AX Type/WGT	1 0.50	1 0.34	1 0.34	1 0.30	1 0.34	1 0.25	1 0.10
AX Type/WGT	1 0.50	1 0.66	1 0.66	1 0.70	1 0.66	1 0.75	1 0.20
AX Type/WGT	0 0.0	0 0.0	0 0.0	0 0.0	0 0.0	0 0.0	2 0.25
AX Type/WGT	0 0.0	0 0.0	0 0.0	0 0.0	0 0.0	0 0.0	1 0.22
AX Type/WGT	0 0.0	0 0.0	0 0.0	0 0.0	0 0.0	0 0.0	1 0.23

COSTS (ECONOMIC)

Vehicle	0.0	0.0	0.0	0.0	5700.00	11050.00	15585.00
Type	11.00	40.00	120.00	100.00	100.00	100.00	150.00
Overhead	0.0	0.0	0.0	0.0	1200.00	1350.00	1900.00
Insurance	0.0	0.0	0.0	0.0	76.00	84.00	96.00
Reg & Lic	0.0	0.0	0.0	0.0	0.0	0.0	0.0
Cargo	0.0	0.0	0.0	0.0	0.0	0.0	0.0
MNT Labor	3.50	3.50	3.50	3.50	3.50	3.50	3.50
Driver	0.0	0.0	0.0	0.0	63.33	68.33	85.83
Helper	0.0	0.0	0.0	0.0	0.0	0.0	0.0
Interest	12.00	12.00	12.00	12.00	12.00	12.00	12.00
Petrol + Lub Gas =	0.12	Diesel =	0.09	Oil =	0.28		
Parts E/F	0.85	0.85	0.85	0.85	0.85	0.85	0.85

VEHICLE UTILIZATION

hrs/Year	2000.00	2000.00	2000.00	2000.00	2000.00	2000.00	2000.00
kms/year	48310.00	48310.00	48310.00	48310.00	48310.00	48310.00	48310.00
Lifetime	5.00	4.00	4.00	12.00	7.00	7.00	15.00

TANZANIA

Names	<u>MED CAR</u>	<u>50P BUS</u>	<u>7T TRUCK</u>	<u>10T TRUCK</u>	<u>22T TRUCK</u>	<u>22T COPP</u>
Category	1	3	4	4	5	5
Fuel Type	1	2	2	2	2	2
VHP	80.	150.	178.	100.	228.	228.
Speed	96.	80.	80.	80.	72.	72.
Tare	0.5	5.0	6.0	10.0	16.0	16.0
Max Load	0.5	5.0	7.0	10.0	22.0	22.0
Axle Type	1 .50	1 .50	1 .49	1 .40	2 .27	2 .27
/Weight	1 .50	1 .50	1 .51	2 .60	2 .33	2 .33
					1 .20	1 .20
					1 .20	1 .20
<u>ECONOMIC</u>						
Vehicle	17349.	49760.	30125.	70400.	91520.	91520.
Tire	125.	774.	687.	774.	1014.	1014.
Overhead		6831.	6418.	6688.	18351.	18351.
Insurance	392.	2172.	1248.	1542.	1584.	1584.
Reg & Lic						
Cargo			.05	.05	.05	.05
MNT Labor	10.	10.	10.	10.	10.	10.
Driver	0.	450.	450.	600.	600.	600.
Helper	0.	150.	150.	150.	150.	150.
Pol	0.54	0.41	2.89			
SRI	/0.	/0.	/0.	/0.	/0.	/0.
Parts E/F	.86	.86	.86	.86	.86	.86
Utilization						
hr/yr	375.	1500.	1600.	1600.	1600.	1600.
km/yr	19200.	48000.	64000.	80000.	96000.	96000.
Years	10.	8.	6.	8.	8.	8.

UPPER VOLTA

<u>Names</u>	<u>LT COMMERCIAL</u>	<u>MINI-BUS</u>	<u>HVY COMMER</u>
Category	2	2	4
Fuel Type	1	1	2
VHP	100	100	200
Speed	102	102	102
Tare Weight	1.5	1.5	7.0
Max Load	.76	.76	11.0
Axle Type/ and % Dis- tribution	1 .50 1 .50	1 .50 1 .50	1 .34 1 .66

ECONOMIC

Veh Cost E	3963.	5456.	22958.
Tire Cost E	40.55	68.66	216.96
Overhead E	991.	13464.	5740.
Insurance E	0.	0.	0.
Reg & Lic E	0.	0.	0.
Cargo/VHR E	0.	0.	0.
MNT LAB E	1.83	1.83	1.83
Driver E	1060.	3720.	6250.
Helper E	0.	0.	0.
POL	.17	.17	1.58
Soc Disc %	12.	12.	12.
Parts E/F	.71	.71	.71
UTILIZATIN			
UTIL hr/yr	2000.	3000.	2500.
UTIL km/yr	30000.	50000.	50000.
Life yrs	8.	8.	8.

APPENDIX B

VEHICLE OPERATING COSTS

Ethiopia

Malawi

Tanzania

Upper Volta

VOC Ethiopian Cents/km

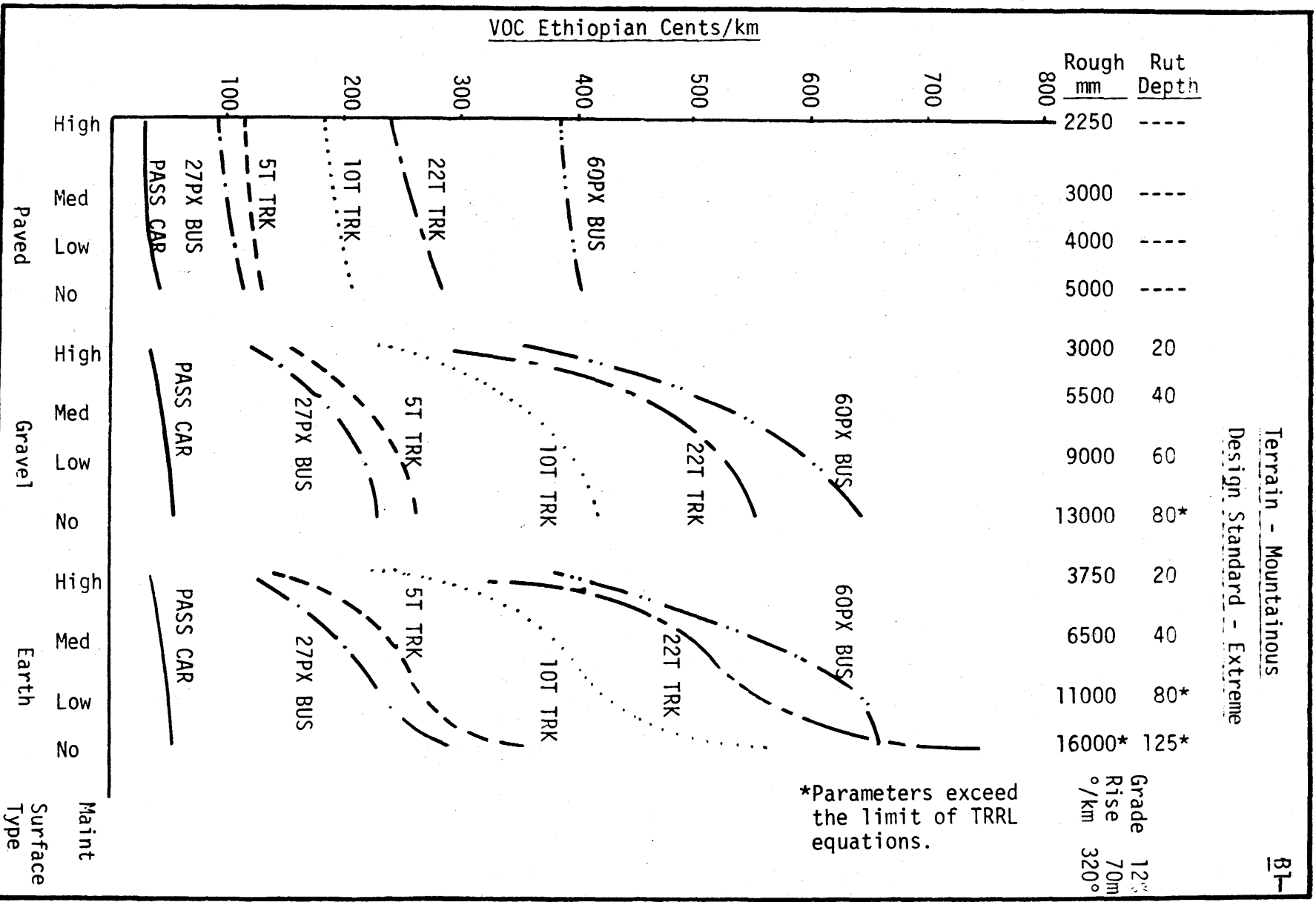

Rough mm  
Rut Depth

2250	----
3000	----
4000	----
5000	----
3000	20
5500	40
9000	60
13000	80*
3750	20
6500	40
11000	80*
16000*	125*

Grade Rise 12%  
70m  
°/km 320°

Terrain - Mountainous  
Design Standard - Extreme

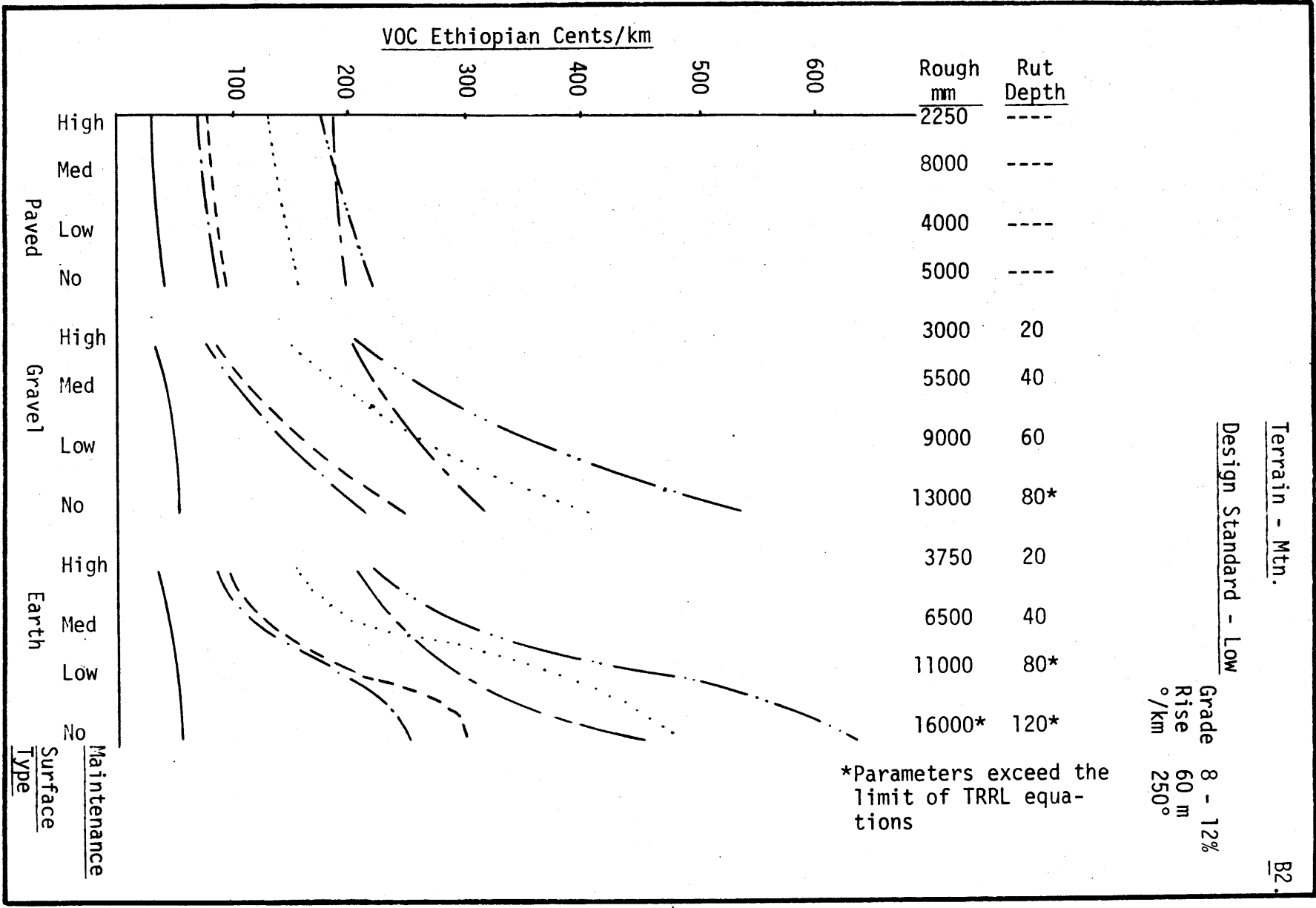

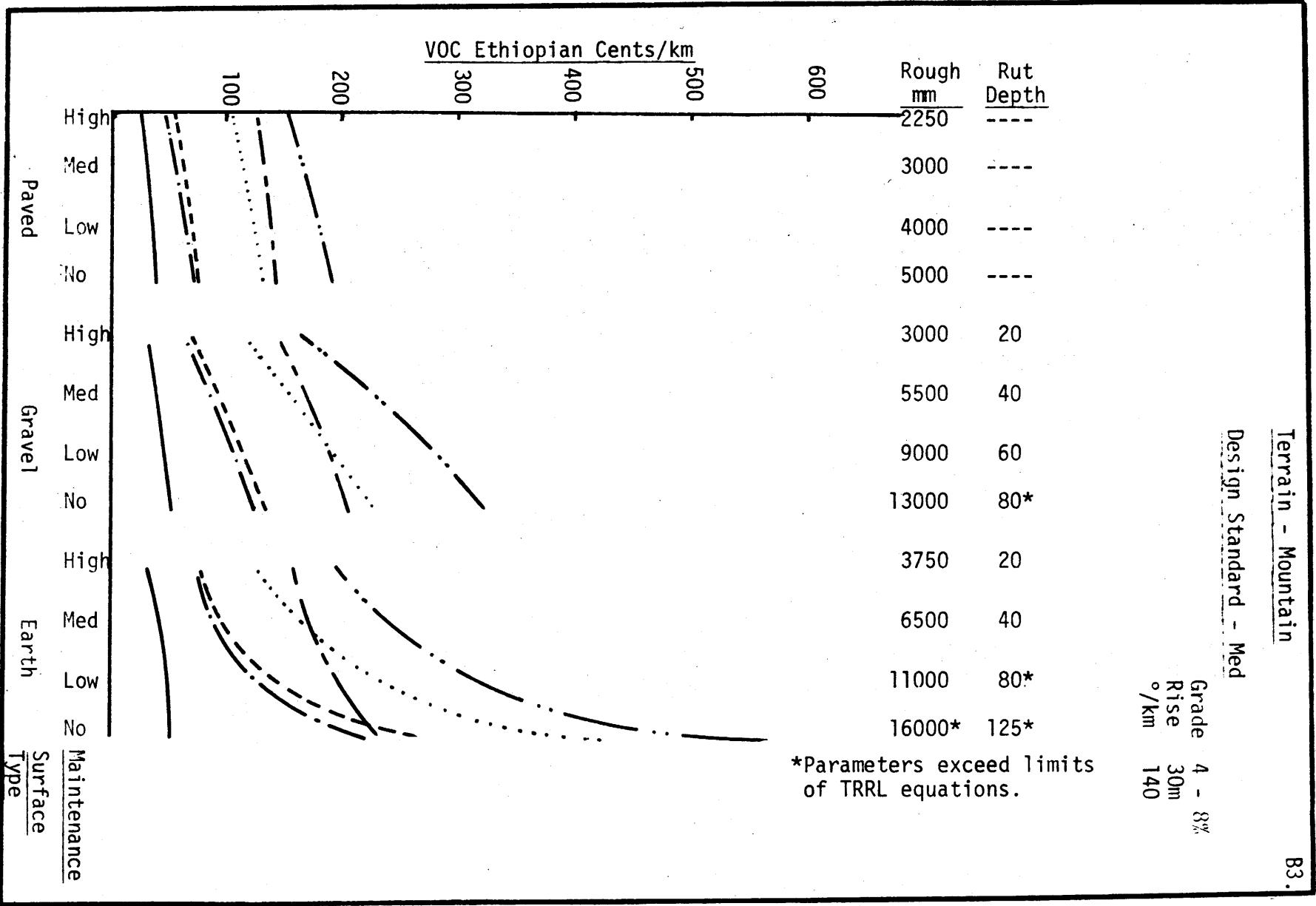

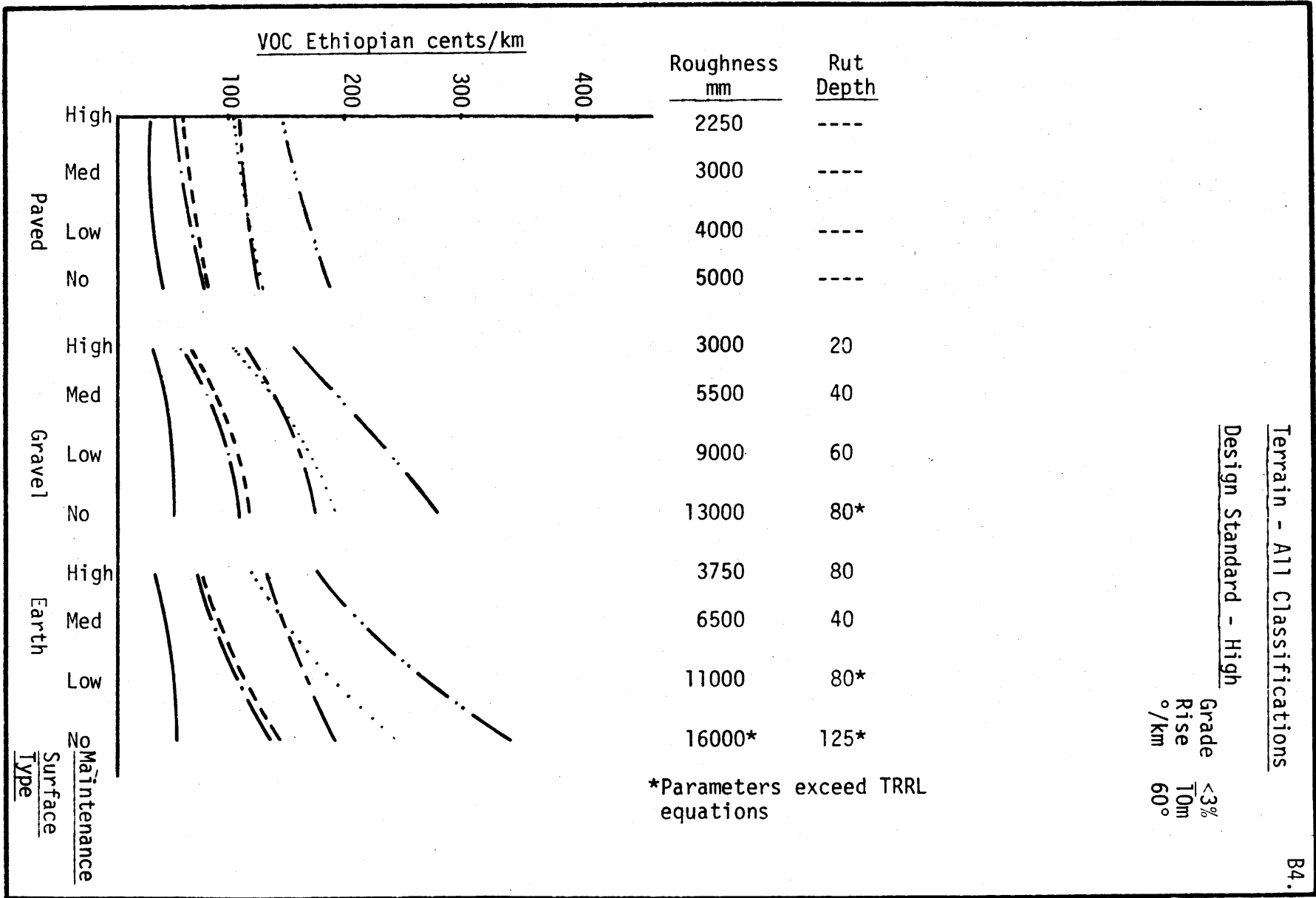



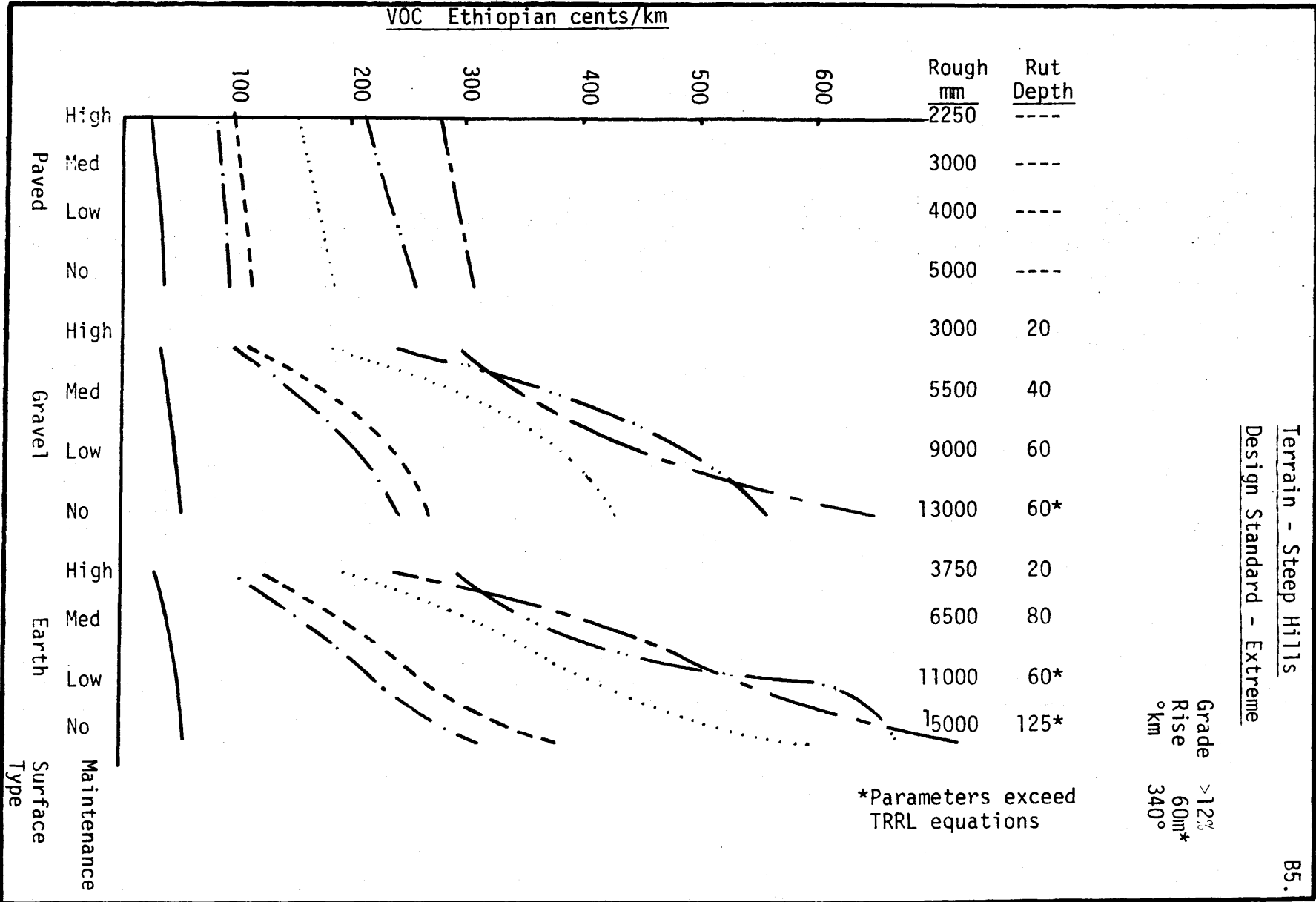

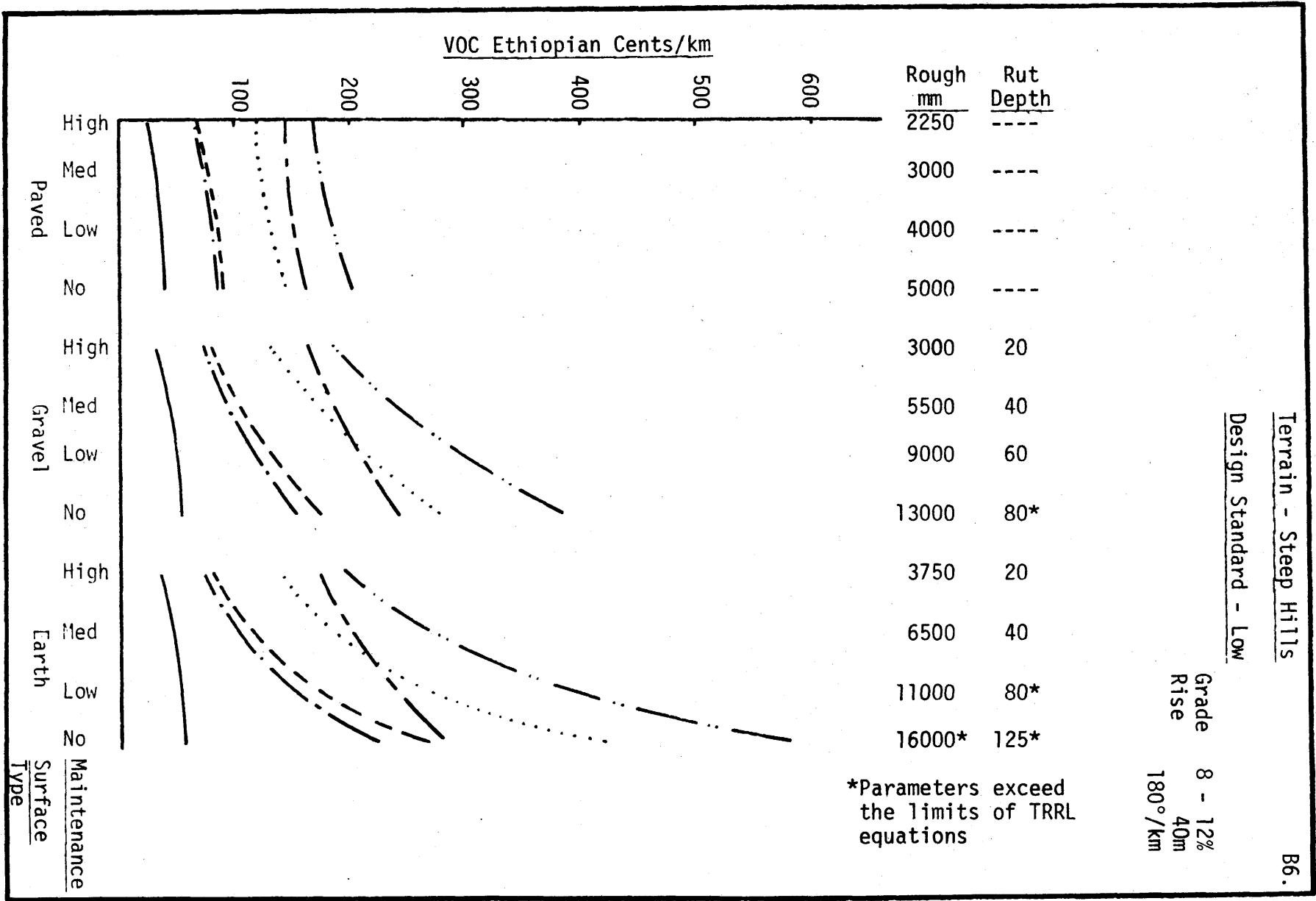

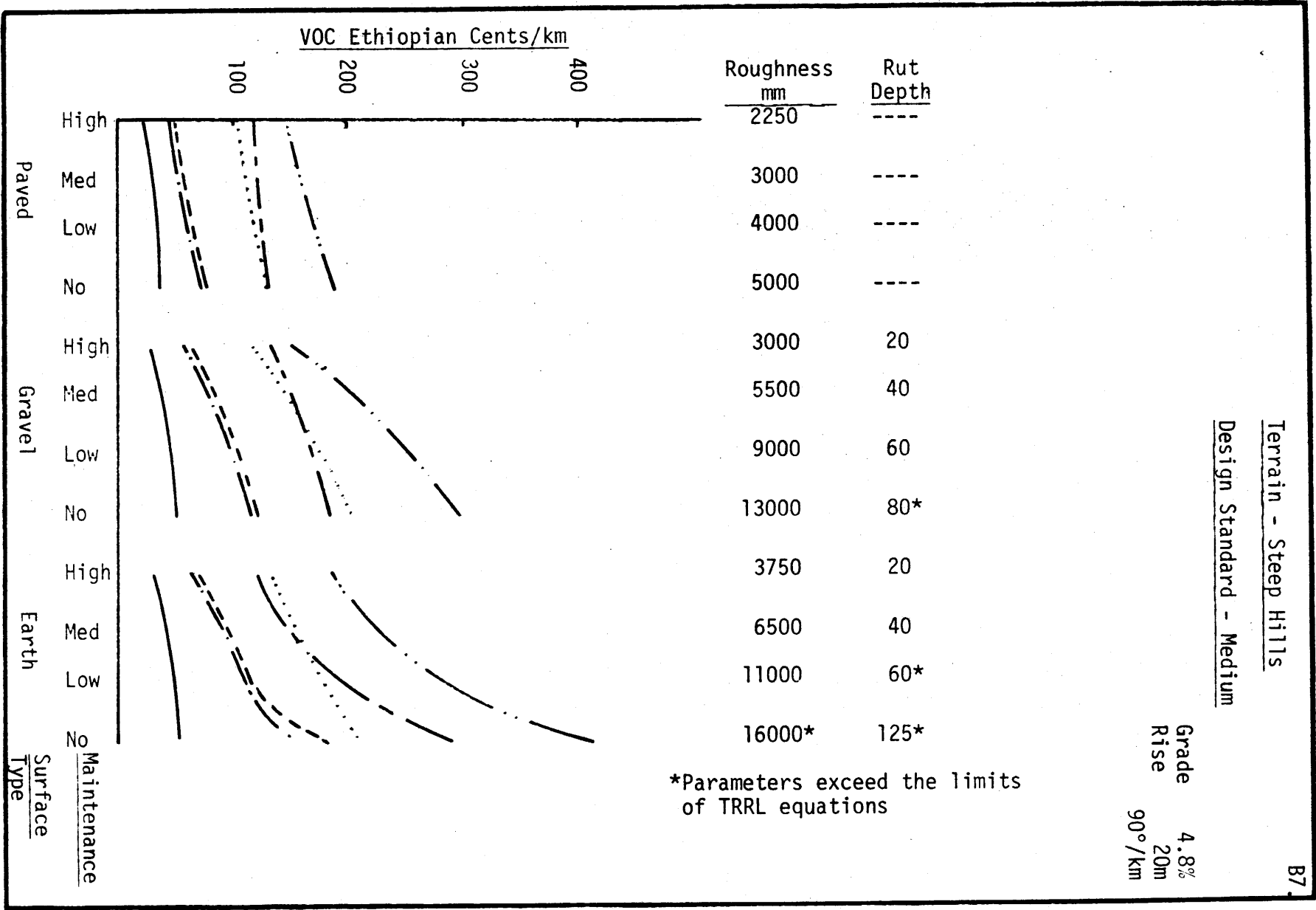

\*Parameters exceed the limits of TRRL equations

Grade Rise 4.8%  
20m  
90°/km

Terrain - Steep Hills  
Design Standard - Medium

Terrain - Rolling Hills

Design Standard - Low and Ext

Grade > 12%  
Rise 30m  
160/km

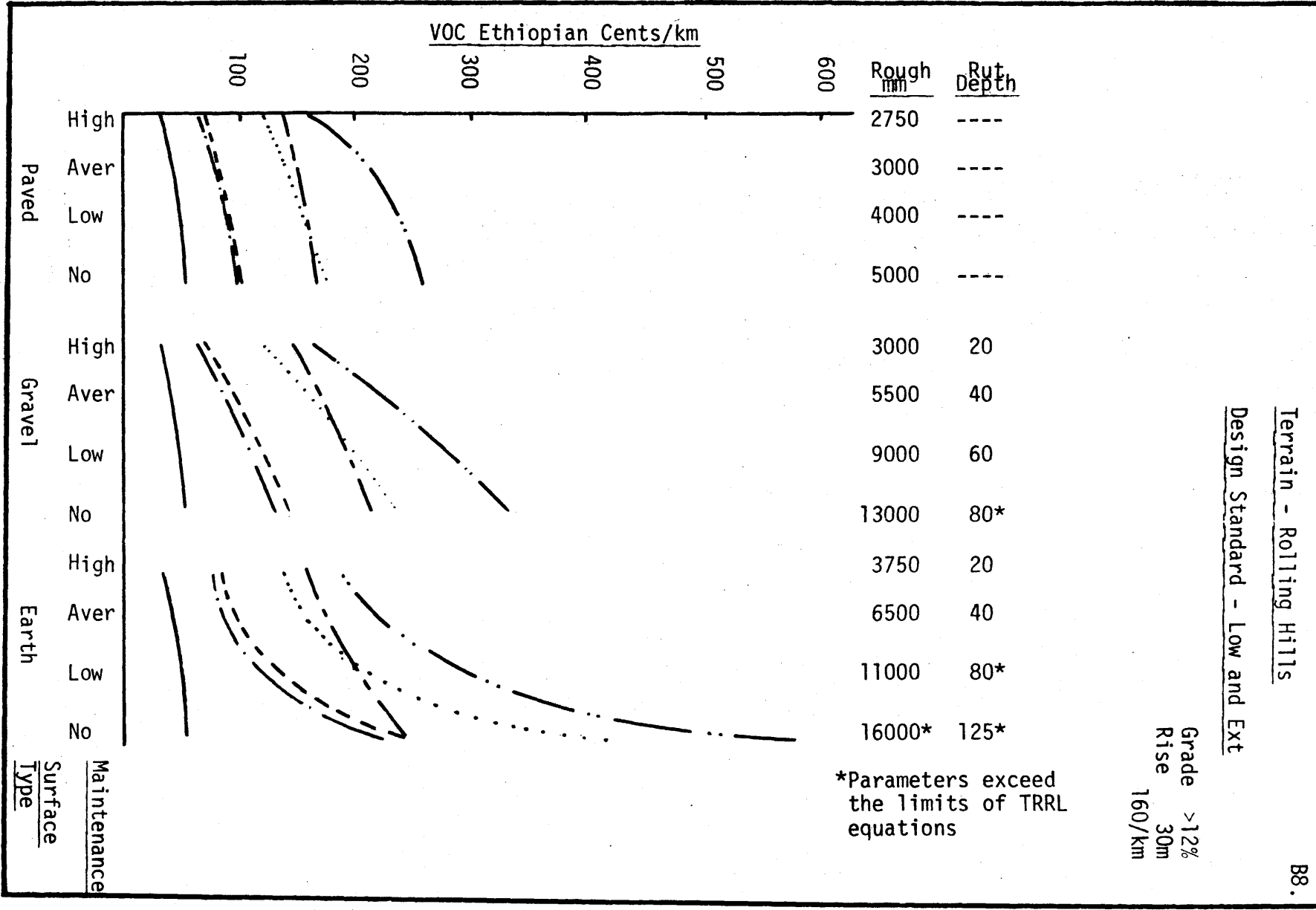

\*Parameters exceed the limits of TRRL equations

VOC Ethiopian Cents/km

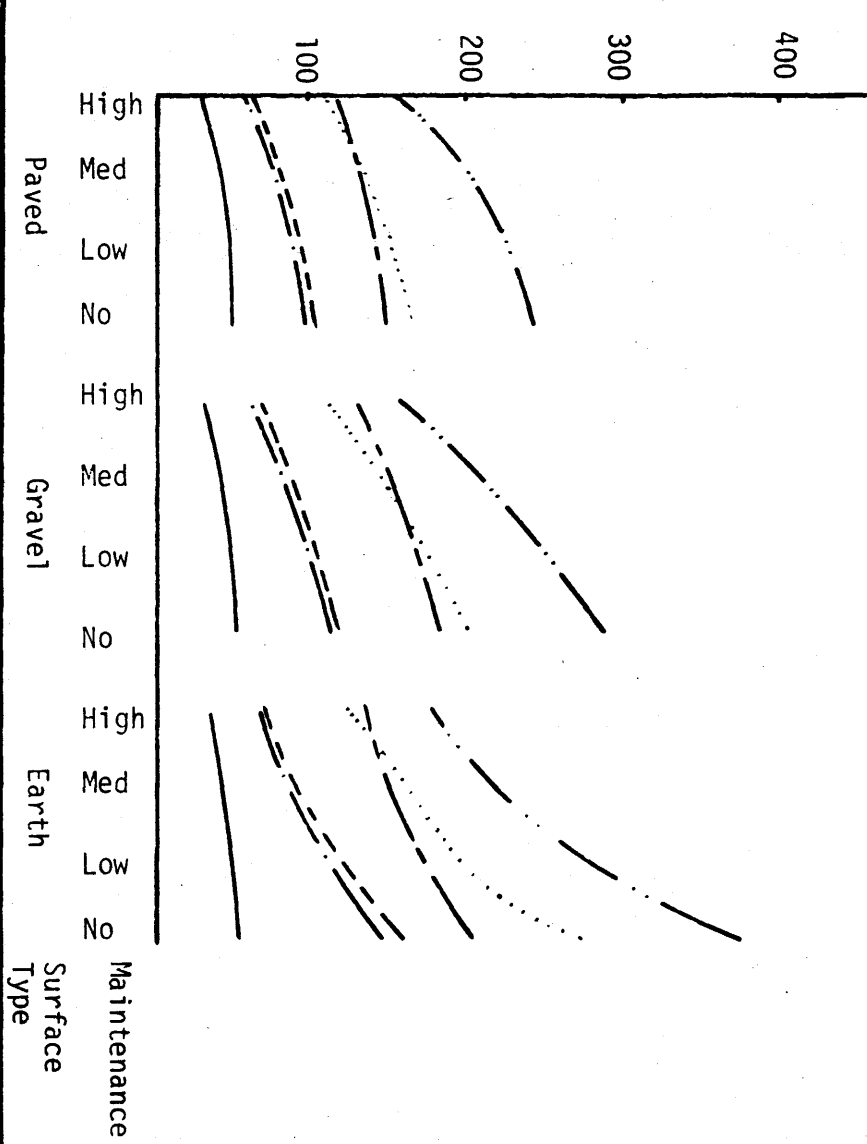

Roughness  
mm

Rut  
Depth

2250	----
3000	----
4000	----
5000	----
3000	20
5500	40
9000	60
13000	80*
3750	20
6500	40
11000	80*
1600*	125*

Terrain - Rolling Hills  
Design Standard - Medium

Rise 20m  
60°/km

B9.

\*Parameters exceed limits of TRRL equations.

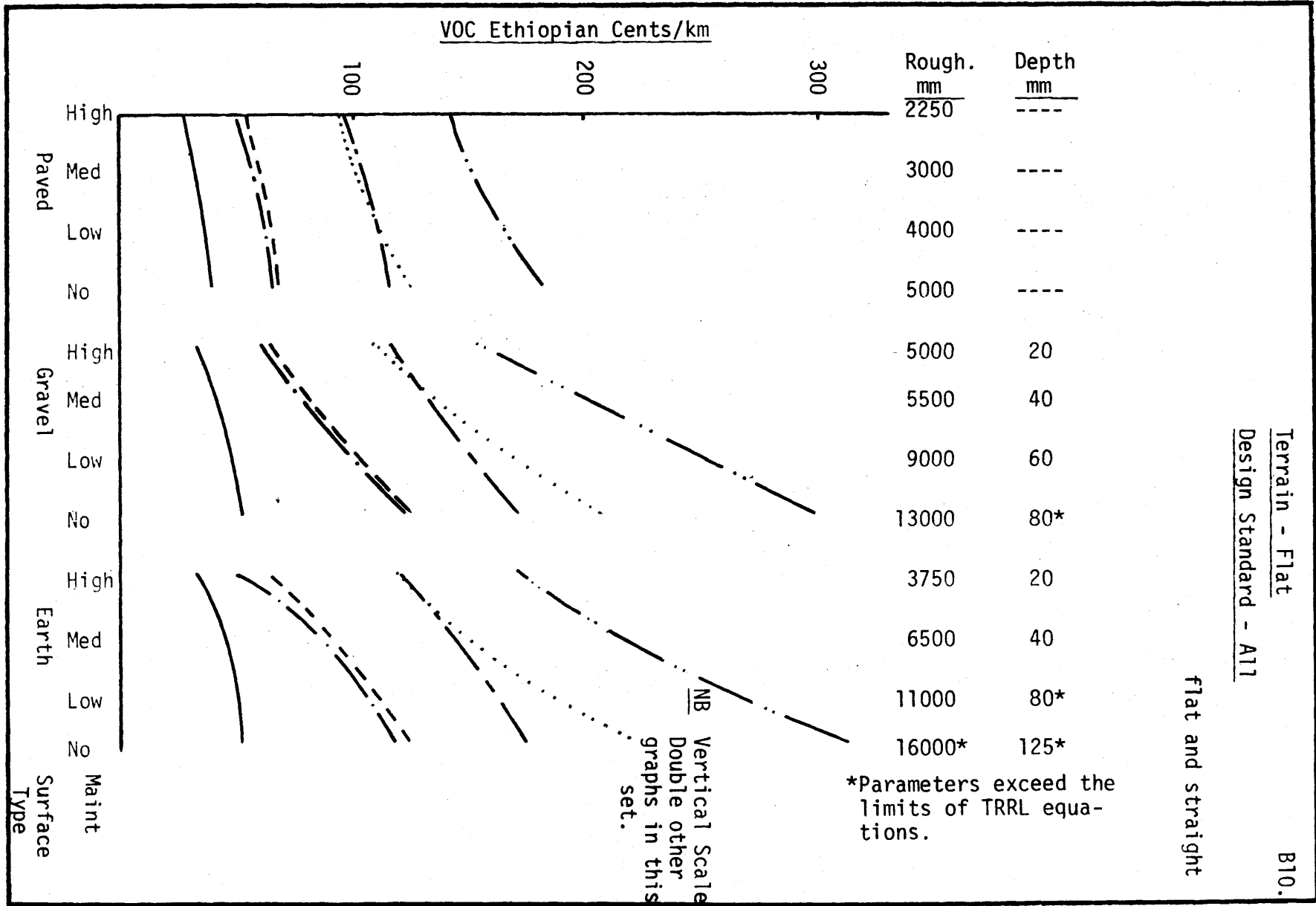

APPENDIX C

GRADER PRODUCTION  
GRADER COSTS

Malawi  
Upper Volta  
Tanzania  
Ethiopia

CONSTRUCTION COSTS

MOTOR GRADER PRODUCTIONAssumptions:

Road width	32'      9.7 m	
Grader speed	5.5 - 12.5 mph	Ref [2]
Overlap factor	0.8	Ref [1]
Blade width	12'	Ref [1]
Angle of blade factor	0.833	Ref [1]
Number of passes	2	
Down time	0.75	

Use average speed = 8 mph.

$$\begin{aligned}
 \text{Time per mile} &= \frac{32 \times 2}{12 \times 0.833 \times 0.8 \times 0.75 \times 8} \\
 &= 1.33 \text{ hrs/mile} \\
 &= 0.83 \text{ km/hr.}
 \end{aligned}$$



MALAWI

Report by: Scott, Wilson, Kilpatrick and Partners  
+ Economic Intelligence Unit

Grading Costs

	<u>k/hr</u>
Grader cost*	8.00
Allow operator 10%	.80
Allow admin. overhead 10%	<u>.90</u>
Total	9.70 k/hr

\*Assumed to include capital cost, repairs and spare parts and fuel costs

UPPER VOLTA

I.B.R.D. Data set for Bobo-Dioulasso-Hounde Road

Grading Costs

	<u>\$/km</u>
Grader and operator	3.19
Unskilled labour	.17
Materials	<u>.72</u>
Total	4.08 \$/km

TANZANIA

By L. F. Basquaro, 1969.

"Aveling Barford" motor grader (126 b.h.p.)

Delivered price at Dar es Salaam	148,250/-
Deduct cost of tyres.	
2 No. @ 1,200/-	
4 No. @ 1,300/-	7,600/-
	140,650/-

Owning Cost per hour.

(a) Amortization + interest (8%) - 6 years, 12,000 hrs.	
= $\frac{140,650 \times 0.21632 \times 6}{12,000}$	15/21 per hr.
(b) Repairs and spare parts. 60% of above	9/12

Operational Cost per hour.

(a) Tyre Consumption 7600 ÷ 3000 hours	2/54
(b) Tyre Repair 10% of above	-/25
(c) Fuel: 4.45 gals @ 2/60	11/55
(d) Luboil: 0.10 gals @ 15/-	1/50
(e) Filter	-/20
(f) Petrol 0.075 gals @ 3/-	-/23
(g) Grease 0.10 lbs @ 2/-	-/20
(h) Operator + grease (2/50 + -/75)	3/25

Total Shs 19/72 per hr.

Note: Costs of fuel and lubricants include transport to the site, use of drums, filling drums, waste, etc.

C4.

$$\text{cost/working hour} = 24/33 + 19/72 = 44/05$$

Say, Shs 44/- per hour.

Add operators transport and admin. overhead 20 %

Total = 53/- per hour

ETHIOPIA

## Road Maintenance Study - Fredric Harris, June 1973

From field studies it was established that production varied between 11 km of light blading and 6 km of heavy blading per 7 hour day. (It is assumed the 7 hr day is to allow for driver inefficiencies and lubrication time.)

The report allows for one heavy blading for every three light bladings; thus after allowing for 25% down time, the average production is 7.3 km/day.

Costs.

Equipment. (rental rate which includes depreciation, fuels lubricants, etc.; only when machine is operating)

Grader 12F size(E\$ 19.00 allow 25% down time)	E\$ 14.25/hr.
--	---------------

Wages.

Equipment operator III	E\$ 2.50/hr
------------------------	-------------

Overhead.

12%	<u>E\$ 2.00/hr</u>
-----	--------------------

Total	E\$ 18.75/hr
-------	--------------

CONSTRUCTION COSTS

Clearing and Grubbing	E\$ 1,400/Ha.
Unclassified Excavation	E\$ 7.10/m <sup>3</sup>
Special Subbase	E\$ 29.70/m <sup>3</sup>
Crushed Rock Subbase	E\$ 38.50/m <sup>3</sup>
DBST Seal Coat	E\$ 2.22/m <sup>2</sup>
Gravelling	E\$ 19.63/m <sup>3</sup>

APPENDIX D

TRAFFIC COMPOSITIONS.

TRAFFIC COMPOSITIONS

<u>ETHIOPIA</u>	<u>Cars</u>	<u>27P Bus</u>	<u>50P Bus</u>	<u>5T</u>	<u>10T</u>	<u>22T</u>
Typical	30	30	6	14	19	-
More Trucks	15	30	6	19	24	5
Less Trucks	40	30	6	9	14	-

<u>MALAWI</u>	<u>Cars</u>	<u>1.5T</u>	<u>Buses</u>	<u>5T</u>	<u>7T</u>	<u>10T</u>	<u>28T</u>
Typical	16	31	3	17	14	8	11
More Trucks	6	21	3	22	19	13	16
Less Trucks	26	41	3	12	9	3	6

<u>TANZANIA</u>	<u>Cars</u>	<u>Buses</u>	<u>7T</u>	<u>10T</u>	<u>22T</u>
Typical	50	5	25	10	10
More Trucks	35	5	30	15	15
Less Trucks	65	5	20	5	5

<u>UPPER VOLTA</u>	<u>Light Comm.</u>	<u>Buses</u>	<u>Heavy Goods</u>
Typical	48	26	26
More Trucks	28	36	36
Less Trucks	68	16	16

APPENDIX E

TRADEOFF BETWEEN VOC AND GRADING COSTS

Lateritic Gravel  
Coral Gravel  
Quartzitic, Volcanic Gravel  
Earth



Tradeoff Between VOC and Grading Costs

Lateritic Gravel

Ethiopia

Typical Traffic Composition

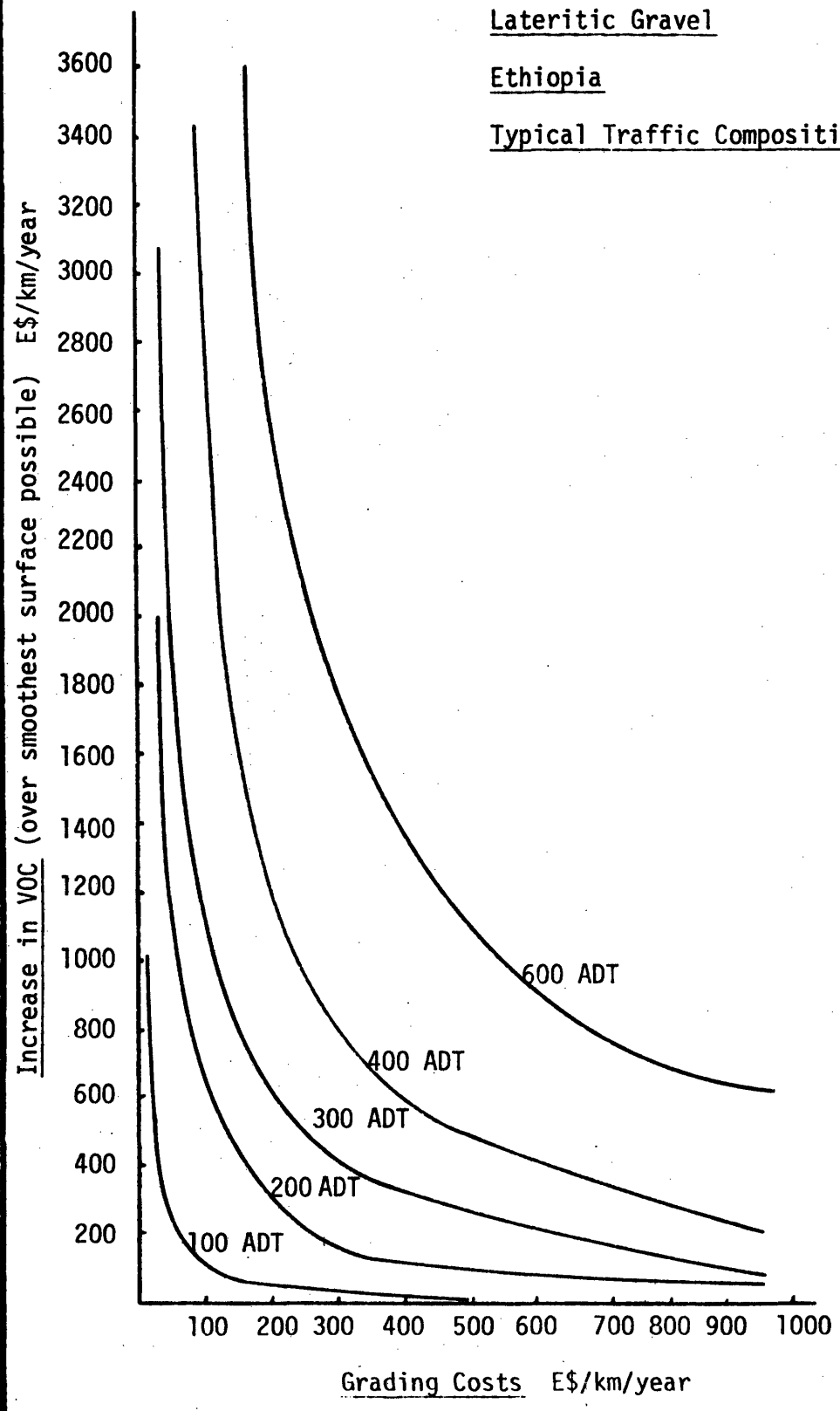

Tradeoff Between VOC and Grading Costs

Lateritic Gravel

Ethiopia

Traffic Composition (More Trucks)

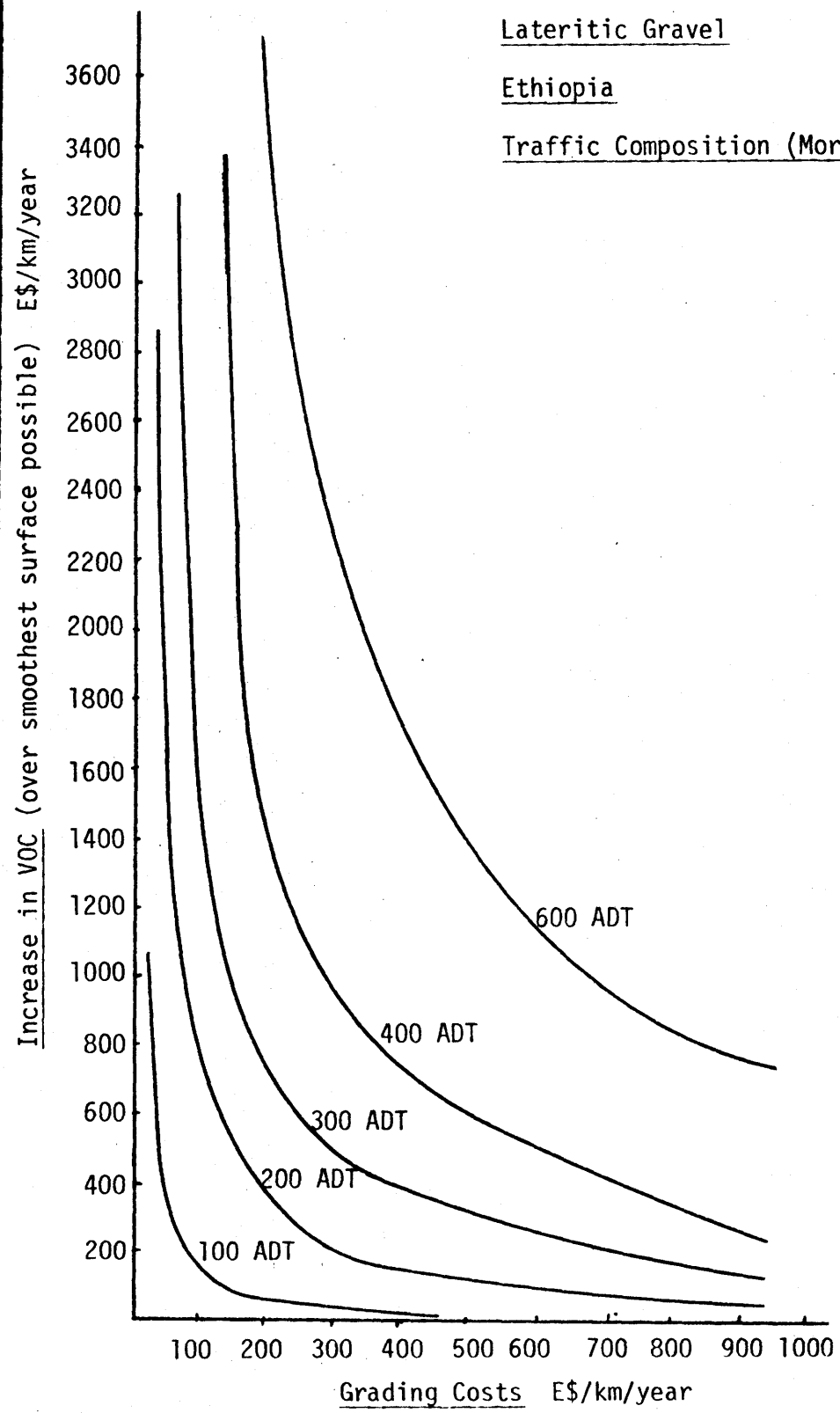

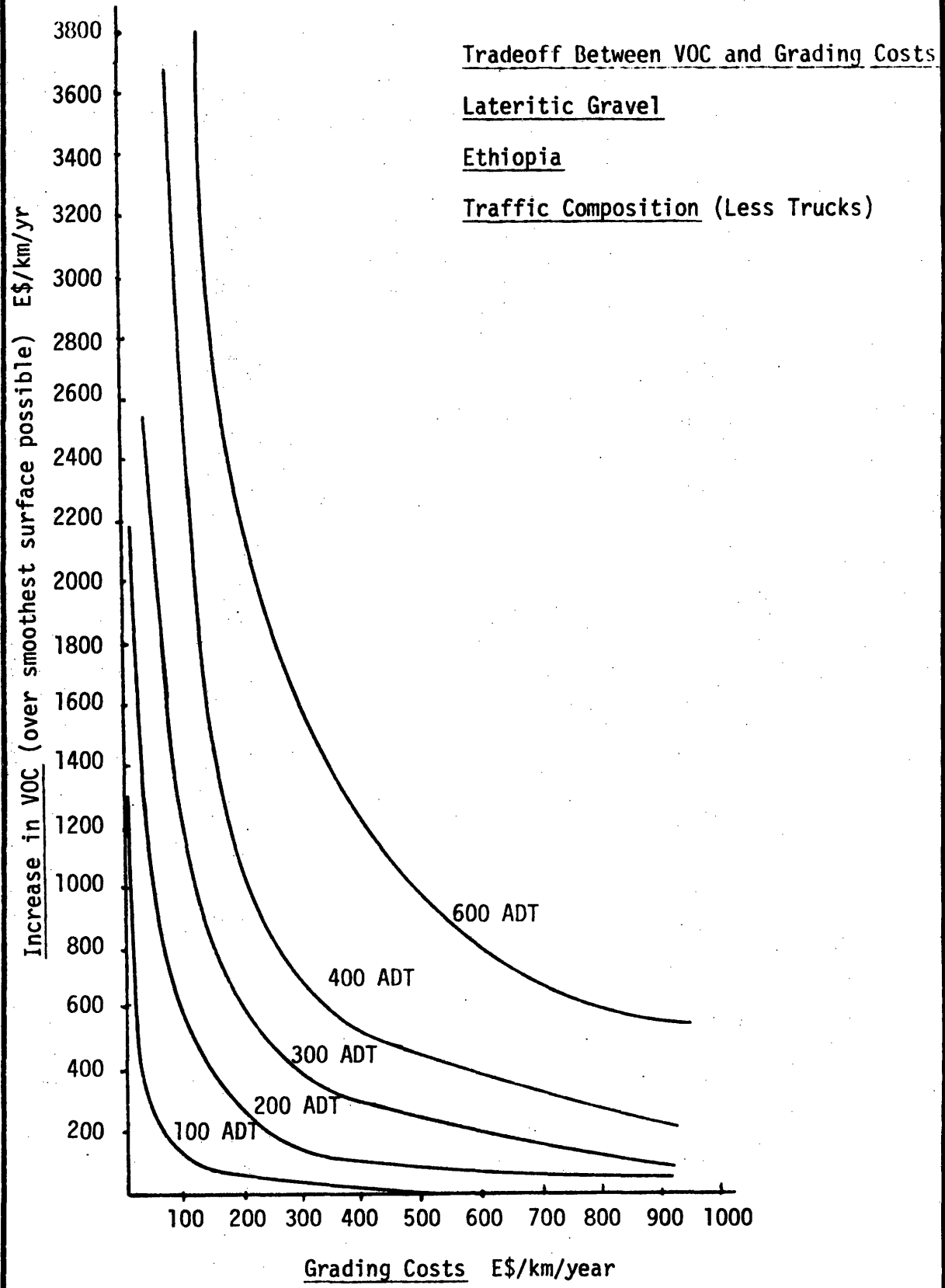

Tradeoff Between VOC and Grading Costs

Coral Gravel

Ethiopia

Typical Traffic Composition

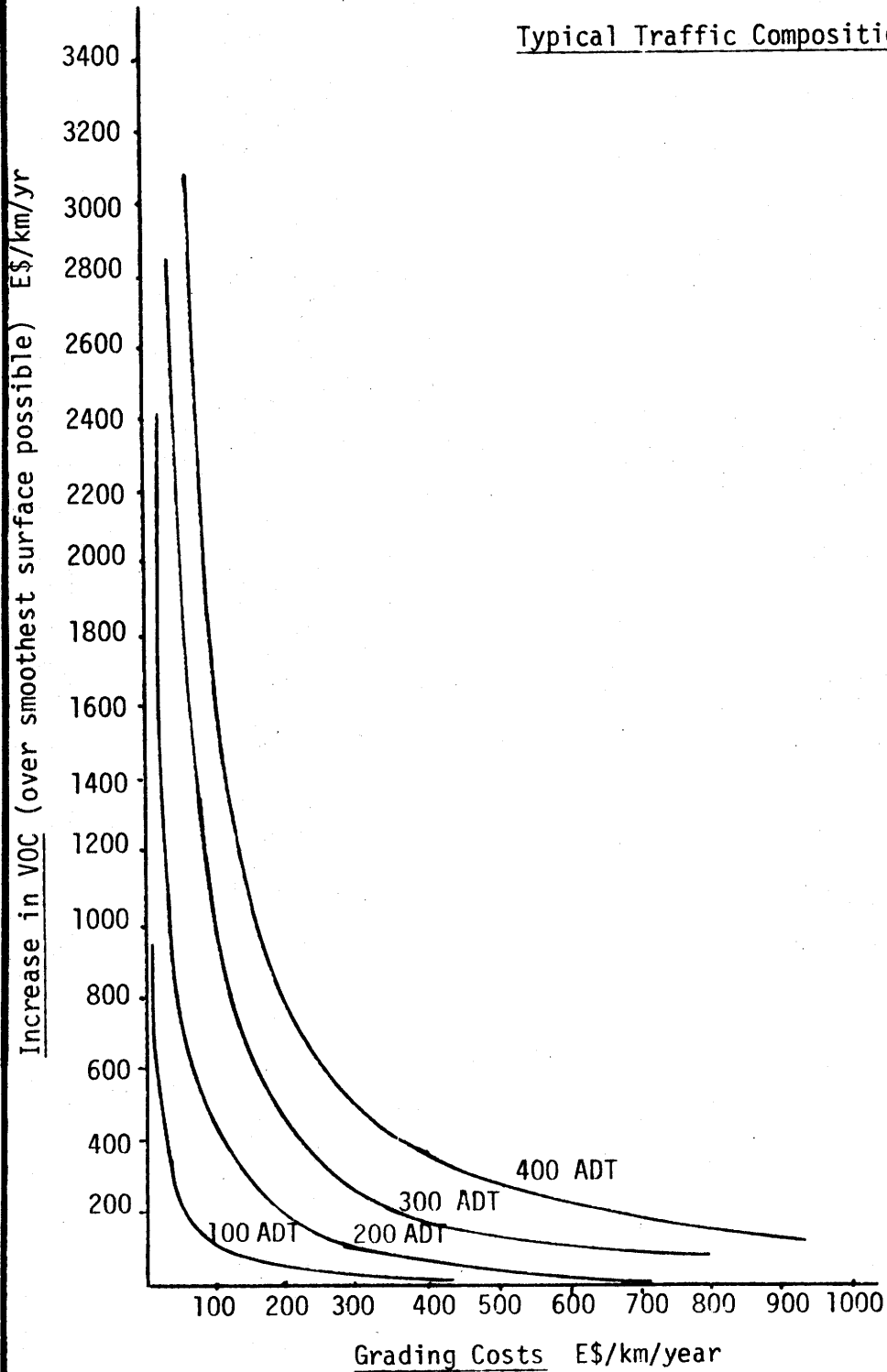

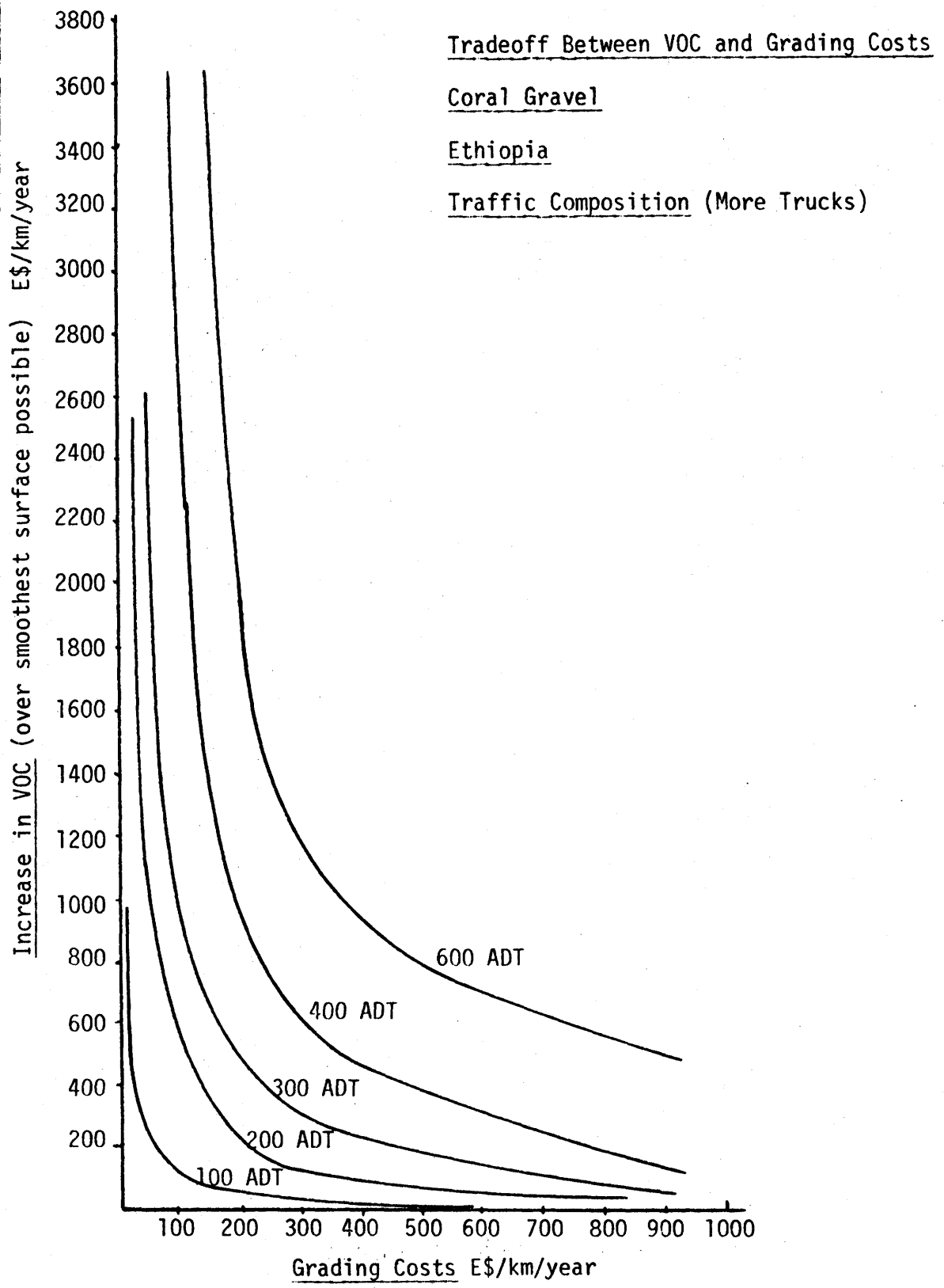

Tradeoff Between VOC and Grading Costs

Coral Gravel

Ethiopia

Traffic Composition (Less Trucks)

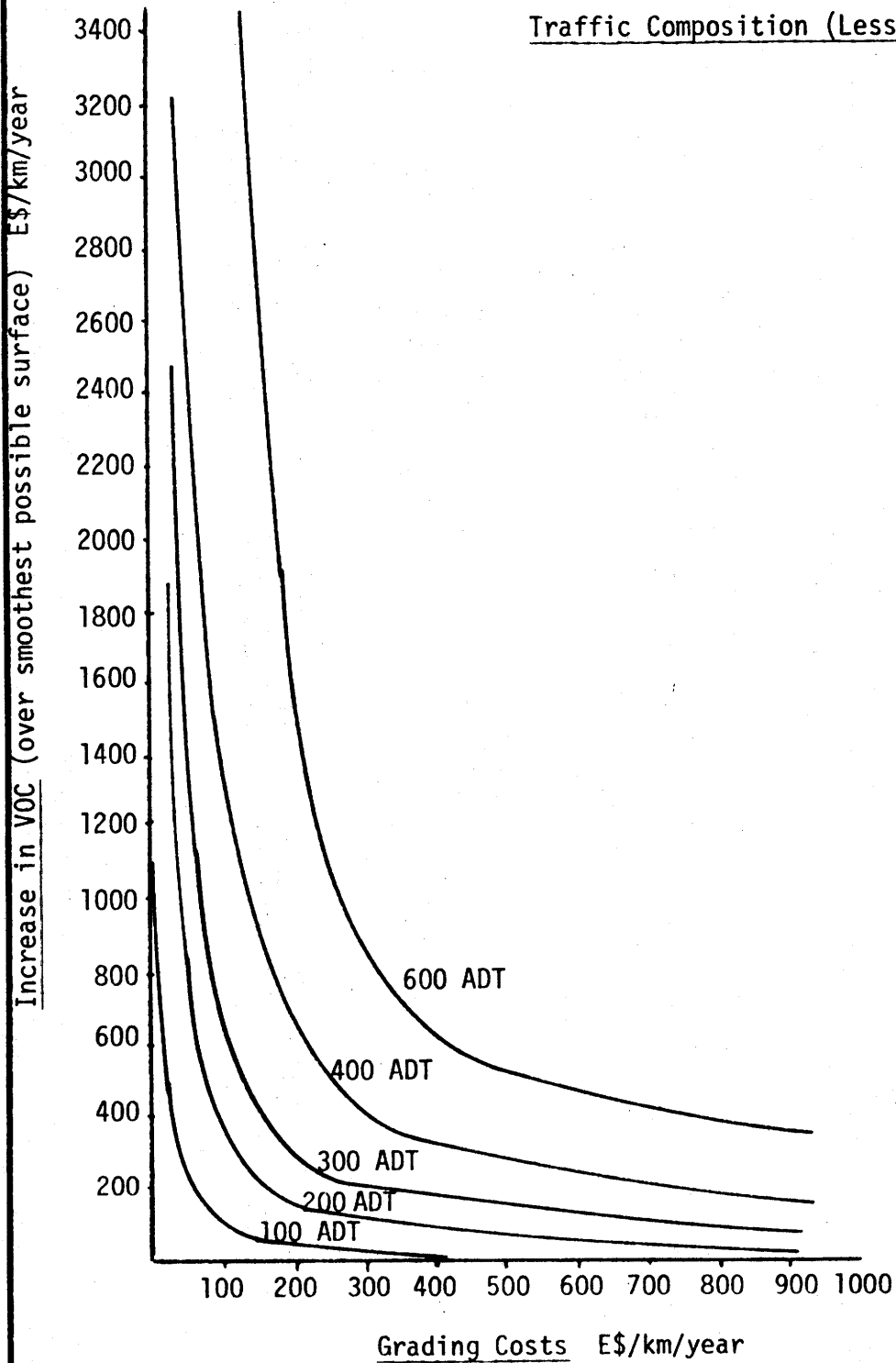

Tradeoff Between VOC and Grading Costs

Quartzitic Gravel

Volcanic Gravel

Ethiopia

Typical Traffic Composition

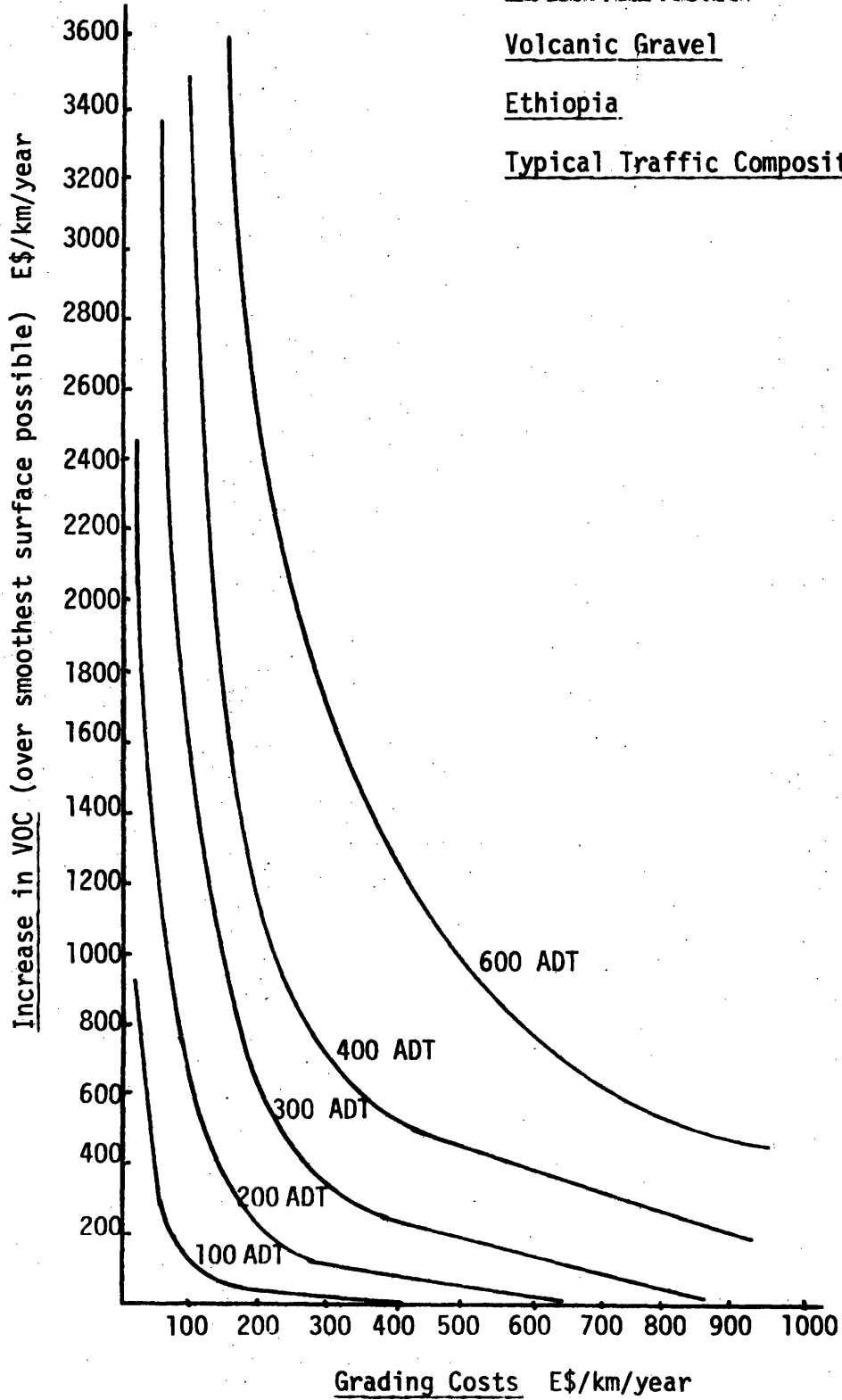

Tradeoff Between VOC and Grading Costs

Quartzitic Gravel

Volcanic Gravel

Ethiopia

Traffic Composition ~ More Trucks

Increase in VOC (over smoothest surface possible), E\$/km/year

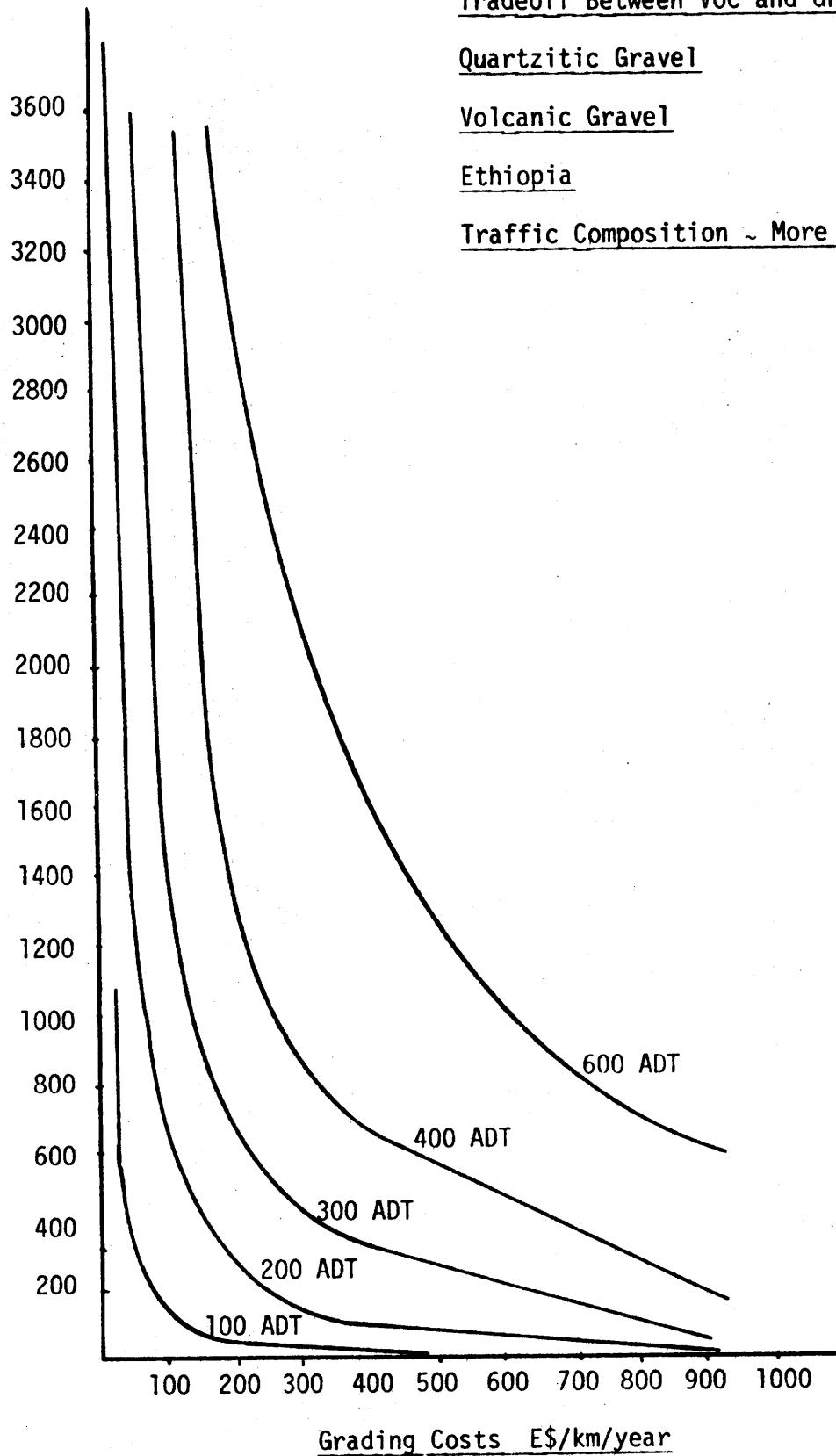



Tradeoff Between VOC and Grading Costs

Quartzitic Gravel

Volcanic Gravel

Ethiopia

Traffic Composition ~ Less Trucks

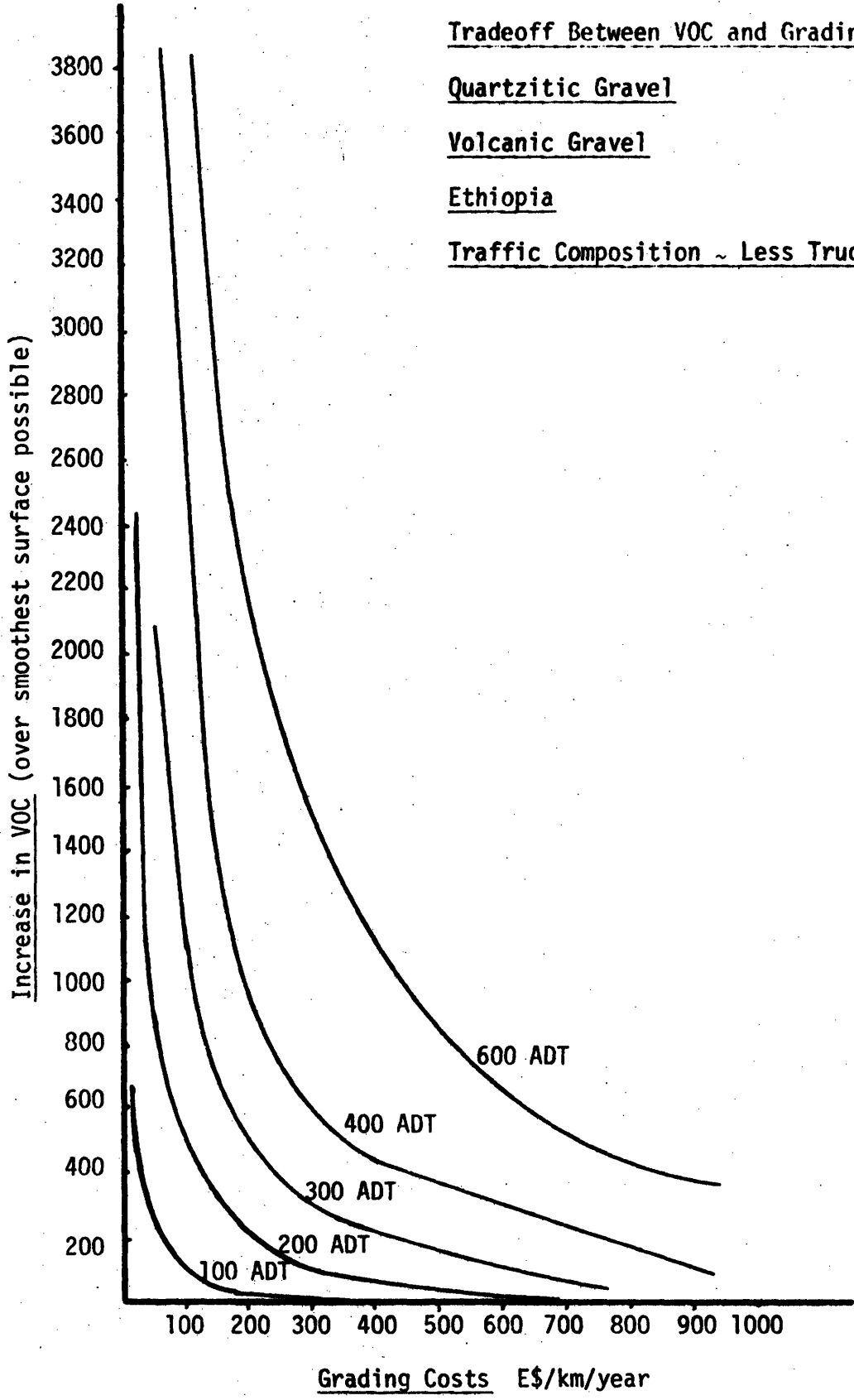

Tradeoff Between VOC and Grading Costs

Earth

Ethiopia

Typical Traffic Composition

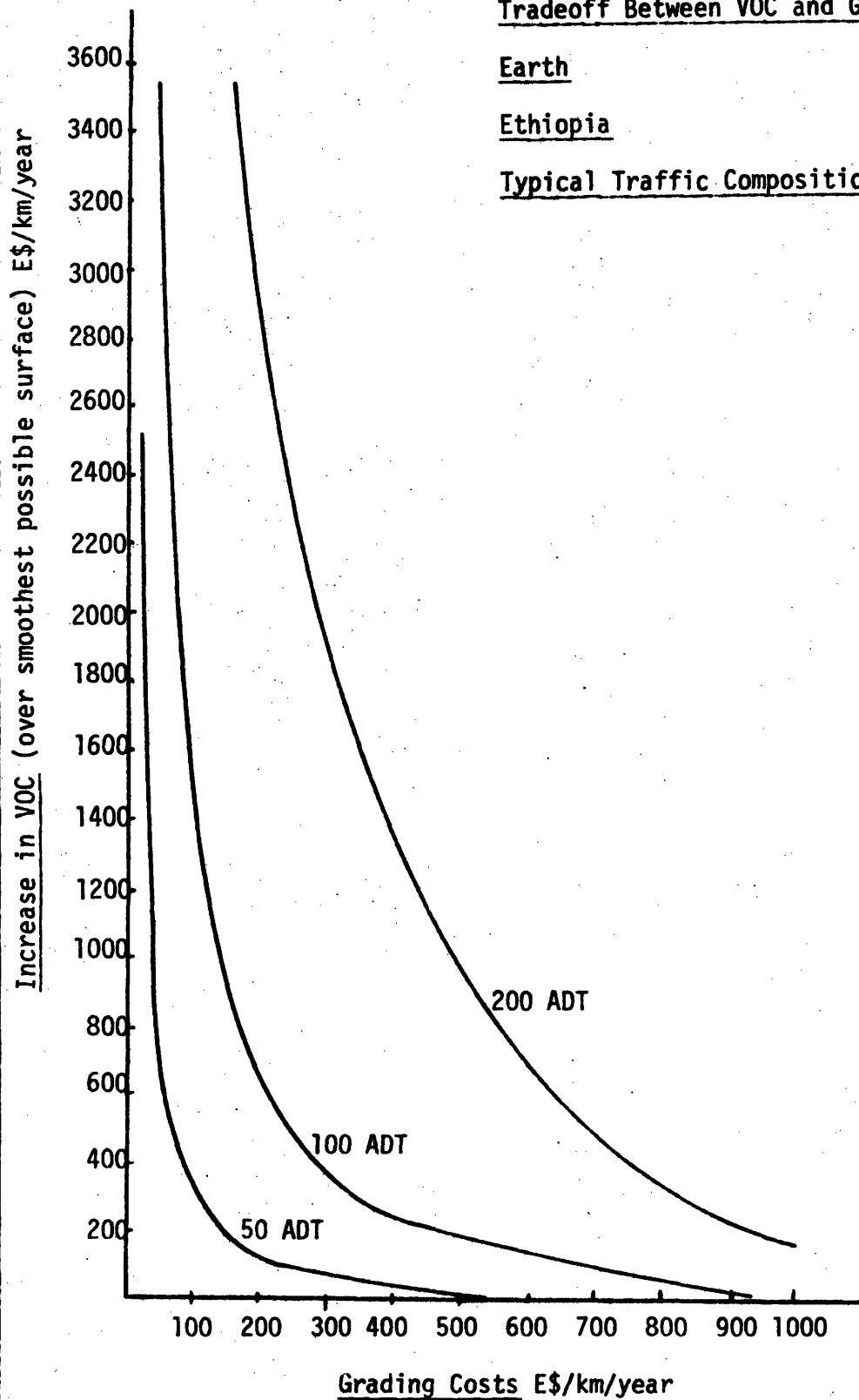

Tradeoff Between VOC and Grading Costs

Earth

Ethiopia

Traffic Composition ~ More Trucks

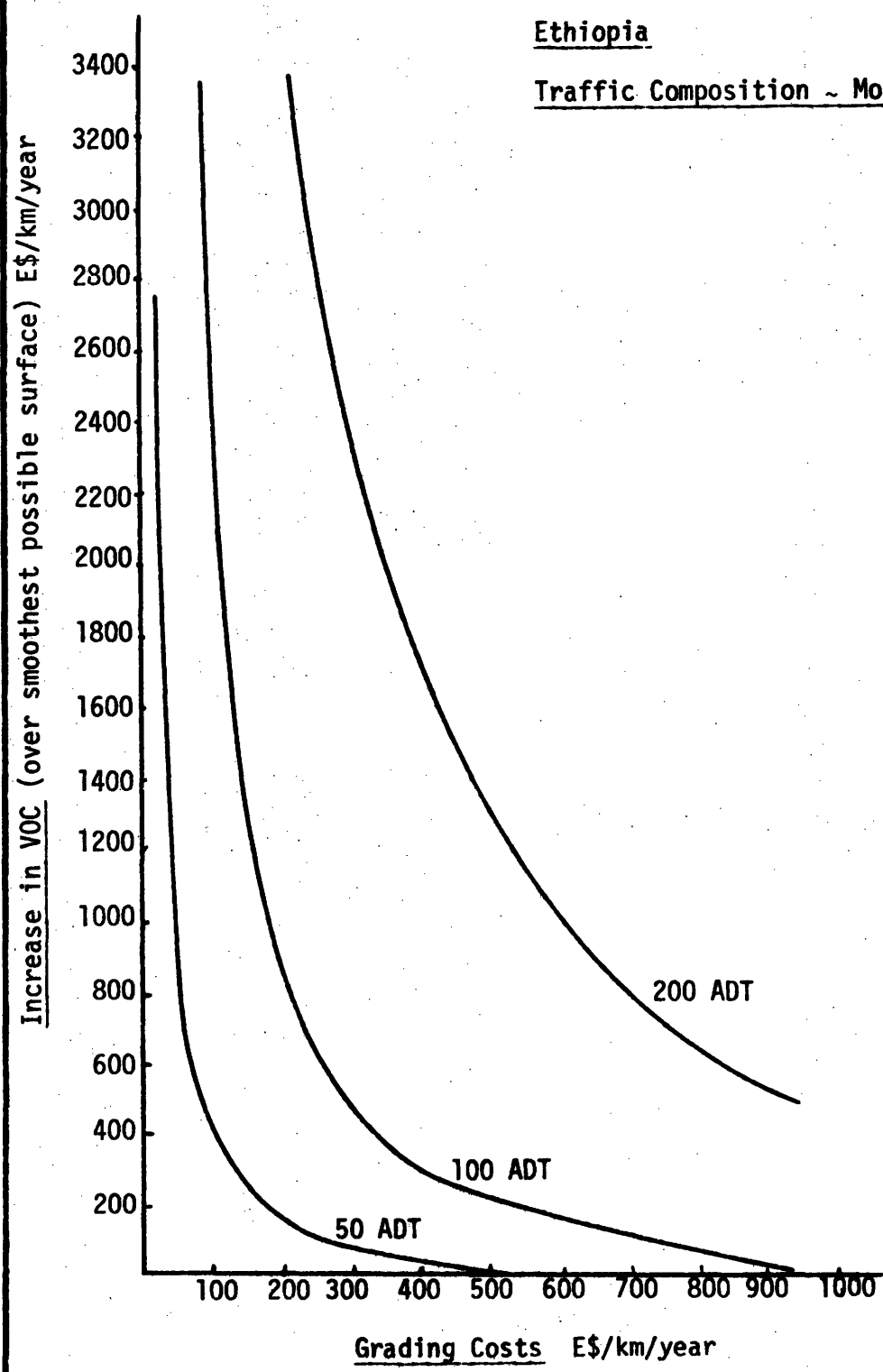

Tradeoff Between VOC and Grading Costs

Earth

Ethiopia

Traffic Composition ~ Less Trucks

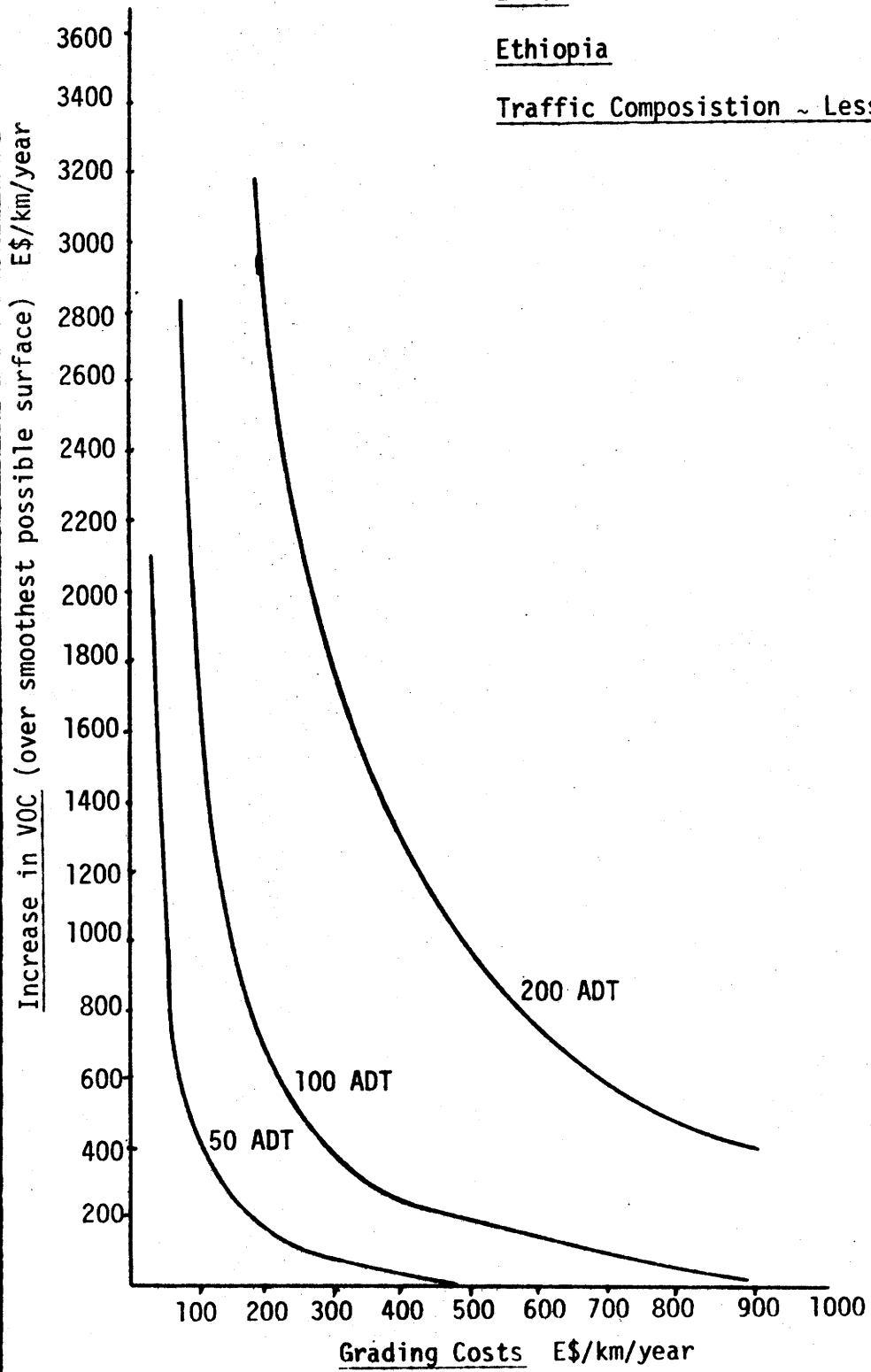

**APPENDIX F**

**TOWARDS MORE RATIONAL AND DRAINAGE FACTORS**

## TOWARDS MORE RATIONAL REGIONAL AND DRAINAGE FACTORS

### Status Quo.

At present the regional factor adopted is the rainfall in metres and the drainage factor is set to unity and they modify the structural number as shown in the equation below, which was derived from the AASHO relationships.

$$(1 + \overline{SN}) = (1 + SN/2.54)(R_L \cdot D_F)^{-0.10684} (CBR/CBR_0)^{0.14744}$$

$\overline{SN}$  = modified structural number

SN = structural number  
where  $SN = A_1 D_1 + A_2 D_2 + A_3 D_3$

A'S = strength coefficient of the material

D'S = depth of material

$R_L$  = rainfall in metres

$D_F$  = drainage factor (set to 1)

CBR = subgrade California Bearing Ratio

$CBR_0$  = subgrade California Bearing Ratio for AASHO tests = 2.69

This relationship captures some of the causal mechanism between rainfall and pavement strength but unfortunately it does not capture the behavioural aspects which will provide more policy sensitivity.

### Shortcomings.

A more complete description of the effect of water penetration on the pavement strength is depicted in Figure 1.

At present total annual rainfall is the input variable and no account is taken of rainfall seasonal variations. In the wet season, when the

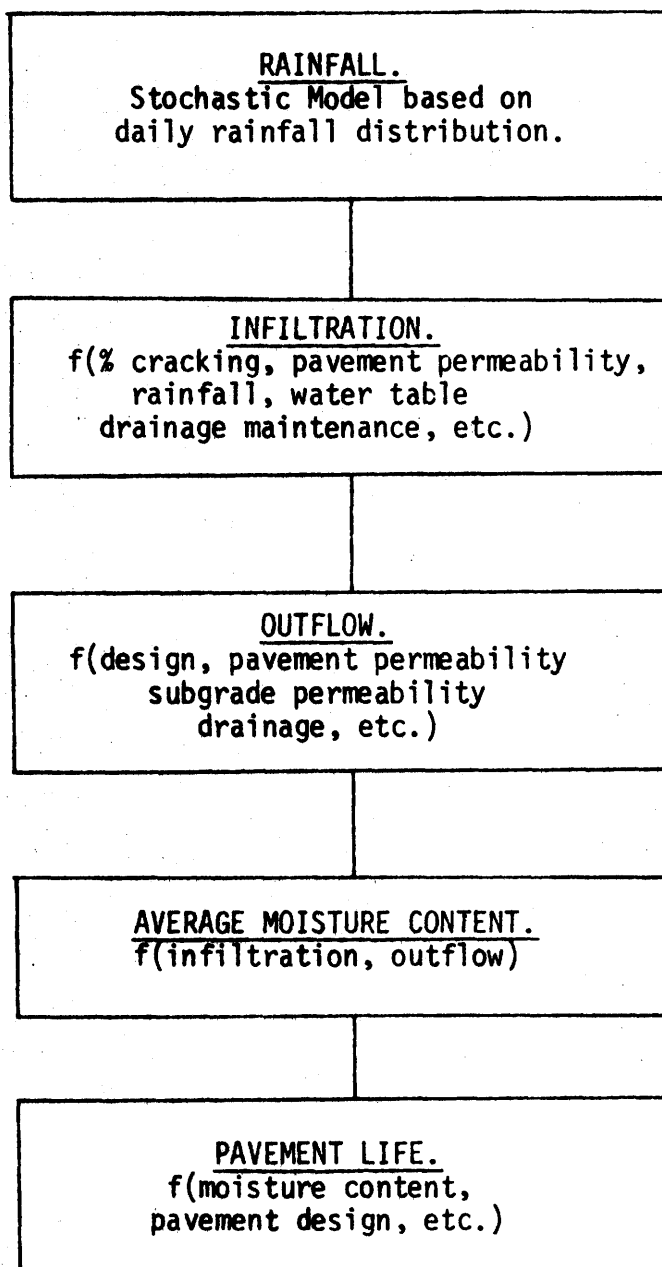

Figure 1

EFFECT OF RAINFALL ON PAVEMENT LIFE

subgrade and other layers become saturated, the pavement strength falls dramatically. Cedergreen [1] claims that strengths may vary by orders of magnitude. (See Table 1.)

The existing relationship makes no allowance for the condition of the surface. Cedergreen [1] claims that by far the major means of water entering the subgrade is via cracks in the surface. The inclusion of this fact into the H.C.M. will not only make the relationship more meaningful but also capture one of the important reasons for maintenance.

Further, certain materials are more susceptible to loss of strength as a result of water intrusion while other materials help drain the pavement rapidly after water penetration and hence increase pavement life and it is felt that better consideration of material properties such as these will improve the HCM's capabilities.

Although the state of the art and the many complexities and variations of soil properties prevents a complete theoretical solution to the problem it is felt that a partly theoretical and partly empirical solution can be developed and this will add to the relationships that exist in the HCM.

#### Moisture Changes Under Sealed Pavements.

##### Inflows.

The sources of inflow are

- (1) surface infiltration
- (2) seepage from higher ground
- (3) rise and fall in the water table
- (4) transfer to or from the shoulders resulting from different water contents.



TABLE 1  
SEVERITY FACTORS IN EXPERIMENTAL ROAD TESTS AS ESTIMATED FROM PUBLISHED REPORTS

TEST	REPORTED BY	BEHAVIOR REPORTED	SEVERITY FACTOR
WASHO road test	HRB Special Report 22, 1955	During worst period, * the rate of deterioration averaged 748 ft <sup>2</sup> /day for 12 load applications per day; during best period, the rate of deterioration was 1.0 ft <sup>2</sup> /day for 1173 load applications per day	70.00:1
AASHO road test	W.J. Liddle, p. 40, <u>Proceedings, First International Conference on Structural Design of Asphalt Pavements</u> , Ann Arbor, Michigan, 1962.	Deteriorating effects of traffic less severe in summer and fall than in spring. Road test data indicate a regional factor of 0.3 to 1.5 should be applied to loads on dry roadbeds (summer and fall) and 4.0 to 5.0 loads on saturated roadbeds.	Practical value between 10:1 and 40:1
University of Illinois circular test track	Ernest J. Barenberg and Owen O. Thompson, <u>Highway Engineering Series No. 36</u> , University at Illinois, January 1970	700,000 load applications (3200-lb load on single tire) produced 0.2 to 0.5 in rutting of unsaturated roadbed; after saturation. 12,000 additional loads destroyed the pavements (test set no. 1)	200:1

\*The frostmelt period

- (5) transfer to or from lower soil layers by capillary action
- (6) transfer of water vapour through the soil.

### Surface Infiltration.

Cedergren [1] claims that the major cause of high moisture contents is surface infiltration.

Water entering a dry soil from a constant supply on the surface distributes itself as shown in Figure [2] below.

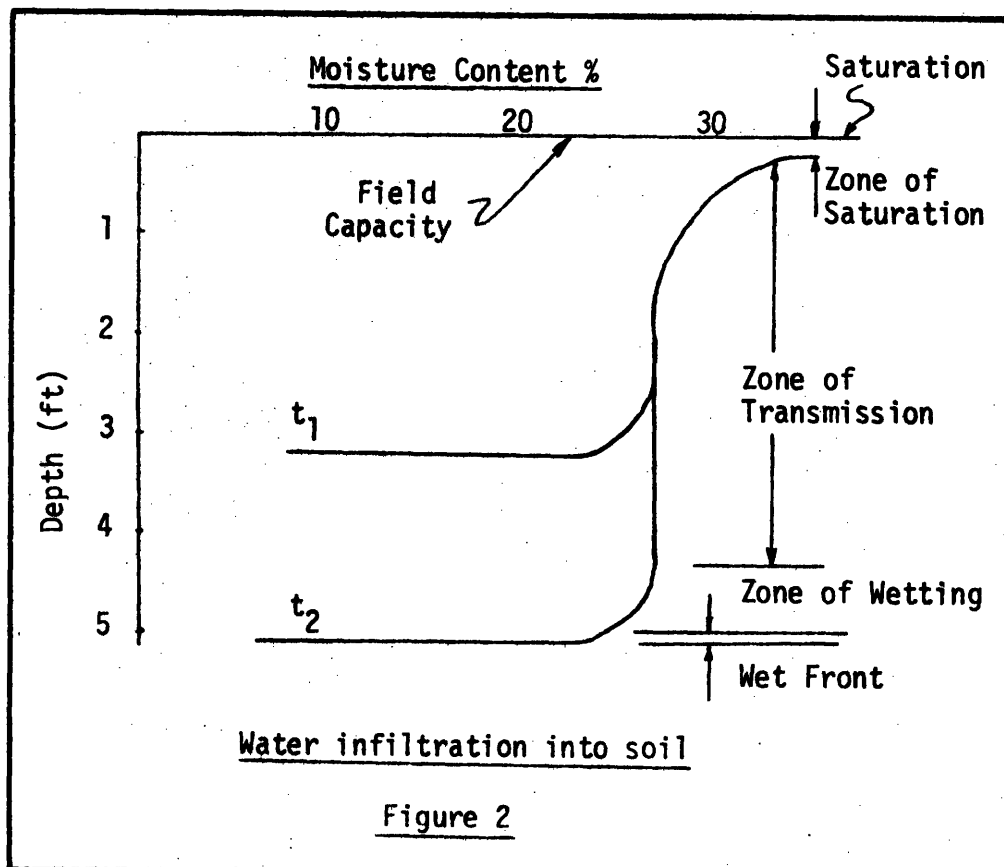

The surface layer is saturated, below this layer the water content decreases rapidly to 70-80% at saturation; a water content between field capacity and saturation. This is the transmitting zone and the water content remains constant or decreases slightly with depth as the wetting increases. Below the transmitting zone is a wetting zone where the water

content of the soil increases rapidly as infiltration continued. The wetting zone ends at the wetting front, which is sharply distinguished as long as infiltration proceeds.

In layered systems the permeability of the least permeable layer controls the downward rate of movement of the wetting front. If the most permeable layer is at the top water infiltration proceeds normally until the wetting front reaches the less permeable layer, then the infiltration rate decreases and the water moves laterally in the upper layer. If the upper layer is confined, the water content of the transmitting zone increases until the upper layer is saturated. Water moves downward into the lower, less permeable layer at a rate controlled by its permeability.

The phenomenon associated with infiltration indicate that in most field infiltration capacity curves approach a steady minimum rate after one or two hours. Figure [3] shows typical curves and Table [2] gives some typical ranges for minimum infiltration rates.

RELATIONS BETWEEN PRECIPITATION AND RUNOFF

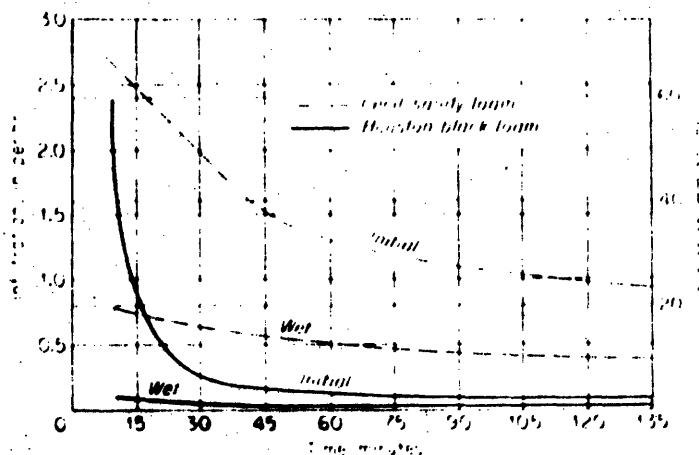

FIGURE 3.  
Comparative infiltration rates during initial and wet run. (From [3].)

<u>INFILTRATION FOR VARIOUS SOILS</u>	
<u>Soil Type</u>	<u>Steady State Infiltration Rate (in/hr)</u>
Sandy, open structured	0.5 - 1.0
Loam	0.1 - 0.5
Clay, dense structured	0.01 - 0.1

TABLE 2

#### Seepage from Higher Ground

Groundwater flows are generally confined to localised areas where excessive sidehill seepage or spring flows exist. To locate these trouble spots field investigations of groundwater should be performed during the wettest period of the year. These problem spots can be treated by various patterns of subsurface drains and cutoffs. The inflows can be quite large and failures will almost certainly result if drains are not installed to prevent water ingress. Because the inflows are localised and require special treatment no attempt will be made to model these effects.

#### Water Table

The pavement should be constructed above the water table and a drainage system should be installed to prevent the water table impinging on the pavement layers. A high water table will reduce the hydraulic gradient and hence the drainage rate of the subgrade and also make it far more probable that capillary water will enter the pavement layers. Therefore in areas where high water tables prevail the regional factors should be increased to take this into account.

### Transfer From Shoulders or Verges

If the soil adjacent to the pavement is saturated, then flow will follow Darcy's Law. Soil suction may exist and this will increase the hydraulic gradient. Russam K and Dagg M [5] concluded that the water penetration into the subgrade under the seal was limited to about three feet. Other conclusions were that the slope of the shoulder affected the amount of water penetration and that gravel shoulders allowed maximum influx of water, while preventing evapotranspiration losses, thus maintaining uniformly wet conditions under the shoulder and much of the subgrade. Infiltration into the shoulders follows the same manner as outlined previously.

### Transfer From Lower Soil Layers

This means of ingress is largely by capillary action and the road should be designed so that it is far enough above the water table to minimize this phenomena.

### Transfer of Water Vapour

This mechanism of transfer is more frequent in arid climates. It should be noted that the moisture transferred by this means is small compared with amounts due to surface infiltration. Also it is essentially confined to maintaining the moisture content throughout the soil in equilibrium and therefore does not produce high levels of saturation in the pavement structure.

Transfer of water by suction and vapour are more associated with soil moisture contents below saturation and therefore may be neglected for this discussion.

### Outflows

The following are possible ways that water can get out of the pavement structural sections.

- (1) surface evaporation
- (2) loss by lateral seepage
- (3) loss by subgrade percolation or drainage
- (4) loss by pumping through cracks or joints
- (5) water removed by subsurface drainage systems

### Surface Evaporation

When pavements do not have effective drainage systems the structural sections may stay in essentially a flooded state for days and during this time some small quantities may be lost by surface evaporation. Cedergren [1] considers losses by this means to be negligible.

### Lateral Seepage

Most materials normally used in shoulder and base construction are fine-grained, relatively dense and low in permeability. Some designers place a permeable drainage blanket under the shoulders to improve drainage and thus reduce excess water. It is possible to determine the outflow by applying Darcy's Law.

FLOW NET FOR DRAINAGE BLANKET

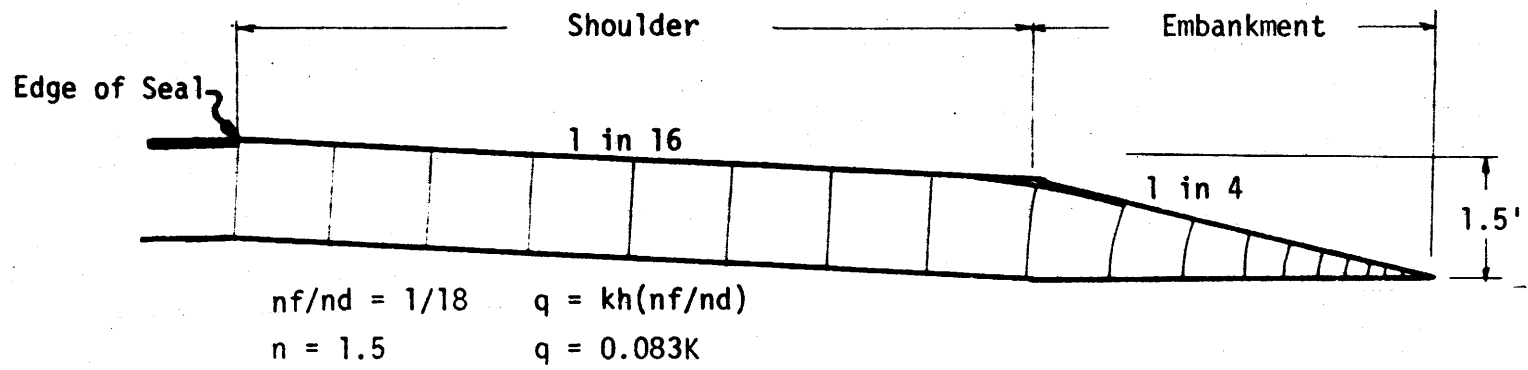

FIGURE 4

The possible drainage rates through shoulder blankets for the flow net in Figure [4] are given in Table [3].

<u>DRAINAGE RATES THROUGH SHOULDER BLANKETS</u>	
<u>Coefficient of Permeability</u> (ft/day)	<u>Drainage Rate</u> (ft <sup>3</sup> /day/ft)
1	.08
10	.83
100	8.33
1000	88.33

Table [3]

As many of the materials frequently used for the construction of roadway shoulders have coefficients of permeability in the range of 1 to 10 ft/day or less, it is evident that only small amounts of drainage via the shoulders can be expected.

Subgrade Percolation.

Again Darcy's Law and the construction of flow nets will provide estimates of the quantity of water drained via the subgrade. If the water table is deep, 50 to 100 ft. below the surface then the effective hydraulic gradient will be of the order of 0.5 to nearly 1.0 and hence the rate of seepage will be considerably greater than if the water table is shallow and the effective gradient much smaller. Typical results for a water table at 14 ft., (hydraulic gradient average = .25) are given in Table [4].



DRAINAGE RATES THROUGH SUBGRADE

<u>Subgrade Permeability</u> (ft/day)	<u>Drainage Rate</u> (ft <sup>3</sup> /day/ft)
.003	0.02
.03	0.18
.3	1.8
3.	18.0
30.	180.0

Table [4]

Since typical subgrades have coefficients of permeability in the range of 0.03 ft/day and lower it is evident that beneficial drainage into subgrades is often quite small.

Pumping Action

The losses caused by pumping are both unpredictable and relatively small and so no attempt will be made to account for these losses.

Water Removed by Drainage System

When pavements on impermeable subgrades are provided with longitudinal pipe drains along the lower edges, the only significant drainage often occurs by internal seepage to the edge drains. The geometrics of base layers make them inherently difficult to drain, (small drainage area and small hydraulic gradients), but drainage of bases can be greatly speeded up by using extremely permeable materials in their construction.

Some typical figures are given in Table [5].

DRAINAGE RATES FOR BASE MATERIALS

<u>Permeability of Base</u>	<u>Discharge Capacity</u>
(ft/day)	(ft <sup>3</sup> /day/ft)
.01	.0001
.1	.001
1.0	0.01
10.0	.1
20.0	.2
3,000	30
10,000	100
20,000	200
30,000	300
50,000	500
70,000	700
100,000	1000
Layer = 12" thick	i = 0.01

Normal Range

Recommended Range

Table [5]

Methodology

As outlined previously the major inflow of water into the pavement structure is by surface infiltration. Neglecting other sources of water ingress, except in special cases, water inflows will be determined solely by surface infiltration. Surface infiltration will be calculated as a function of the percentage of the surface cracked, rainfall and the permeability of the pavement base layers. The outflow rate will be determined from the subsurface drainage characteristics, (if subsurface

drainage exists) or the drainage rates of the shoulders and subgrade.

From the inflow and outflow rates and rainfall data an estimate of the amount of saturation of the roadbed and the number of days of the year it is in that state will be obtained.

### Rainfall

The use of Ethiopian rainfall data makes the following example Ethiopian specific but the same methodology should yield satisfactory results for other countries. The following data essentially from reference 8 and is typical of what is available in the literature.

Figure [5] shows the average annual rainfall for the Ethiopian highlands. The mean monthly rainfall and the annual rainfall variation are given in Tables [6] and [7] respectively.

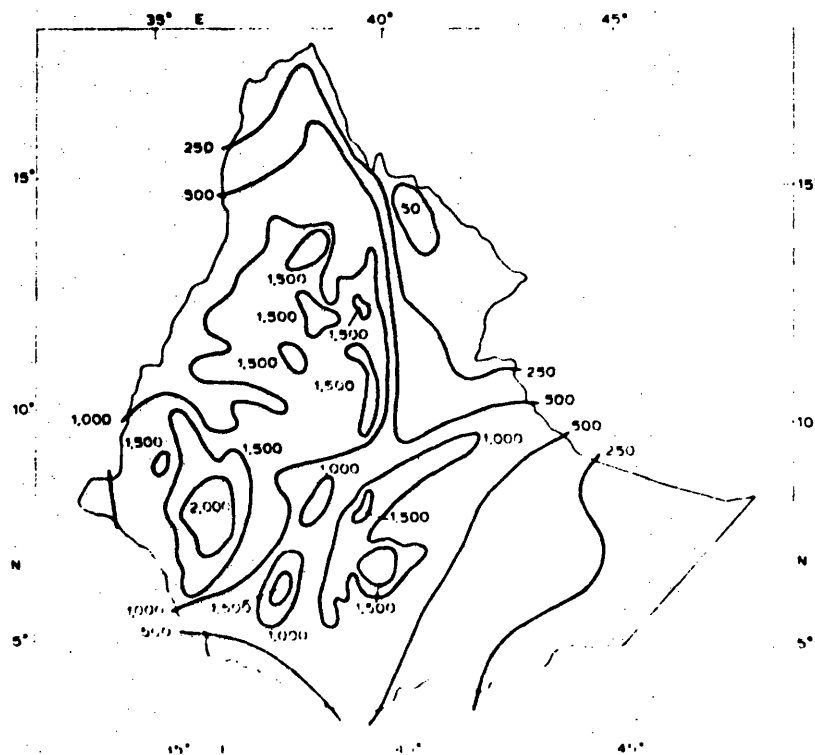

Fig. 5 Mean annual rainfall (mm) - simplified

TABLE 6

## MEAN MONTHLY AND ANNUAL RAINFALL (MM)

	Jan.	Feb.	Mar.	Apr.	May	June	July	Aug.	Sept.	Oct.	Nov.	Dec.	Ann
Moyale	11	17	55	182	118	17	17	17	25	96	86	41	682
Neghelli	8	4	33	172	102	8	6	7	16	119	52	23	550
Magalo	14	7	92	92	95	4	21	34	54	107	6	7	532
Uondo	26	60	107	149	147	109	203	202	154	85	45	12	1,302
Adamitullo	12	24	35	60	66	56	109	94	83	16	9	13	577
Saiyo	11	33	68	139	198	192	194	216	142	79	50	18	1,342
Gore	29	51	85	136	276	307	276	313	314	163	76	33	2,059
Gambela	6	9	37	86	154	171	241	236	192	99	44	13	1,289
Daga Dima	73	53	147	118	108	142	170	140	140	97	41	14	1,243
Dembidollo	11	33	68	139	198	192	194	216	143	79	50	19	1,342
Bakaksa	40	57	137	193	257	178	204	186	201	126	98	26	1,702
Harar	11	32	60	109	121	101	142	137	98	46	23	10	889
Dire Dawa	20	29	43	83	30	23	108	165	70	12	17	10	582
Kurmuk	0	0	6	17	114	153	175	194	163	97	7	2	928
Bure	30	9	66	122	174	168	183	138	138	173	137	26	1,302
Dangila	5	10	25	62	122	224	319	301	207	78	40	6	1,399
Quoram	21	43	87	89	78	17	179	253	76	54	19	75	991
Gondar	0	5	9	57	77	182	369	356	122	47	18	3	1,246
Gallabat	0	0	5	17	74	166	193	239	164	30	2	0	890
Adi Ugri	0	1	15	31	34	64	193	161	49	7	10	1	565
Ghinda	152	89	80	74	58	15	44	52	30	77	52	99	826
Fil-Fil	162	204	89	120	15	0	42	0	15	104	120	252	1,123
Mt. Sabur	163	148	98	60	54	23	100	102	31	103	94	149	1,125

TABLE 7

## ANNUAL RAINFALL, ADDIS ABABA (mm), 1900-1959

Decade	Year									
	0	1	2	3	4	5	6	7	8	9
1900	1,165	1,241	985	1,133	1,107	1,104	1,513	1,047	1,132	1,263
1910	1,269	1,076	1,161	1,175	1,439	1,901	1,730	1,591	960	992
1920	1,076	1,039	1,061	1,321	1,905	1,476	1,755	1,271	1,342	1,244
1930	1,461	1,022	975	1,181	1,027	1,283	1,419	1,134	1,053	1,133
1940	937	1,106	1,154	1,054	1,083	1,006	1,138	1,261	1,413	1,351
1950	956	934	1,081	923	1,164	1,276	1,027	1,317	1,309	1,043

F16.

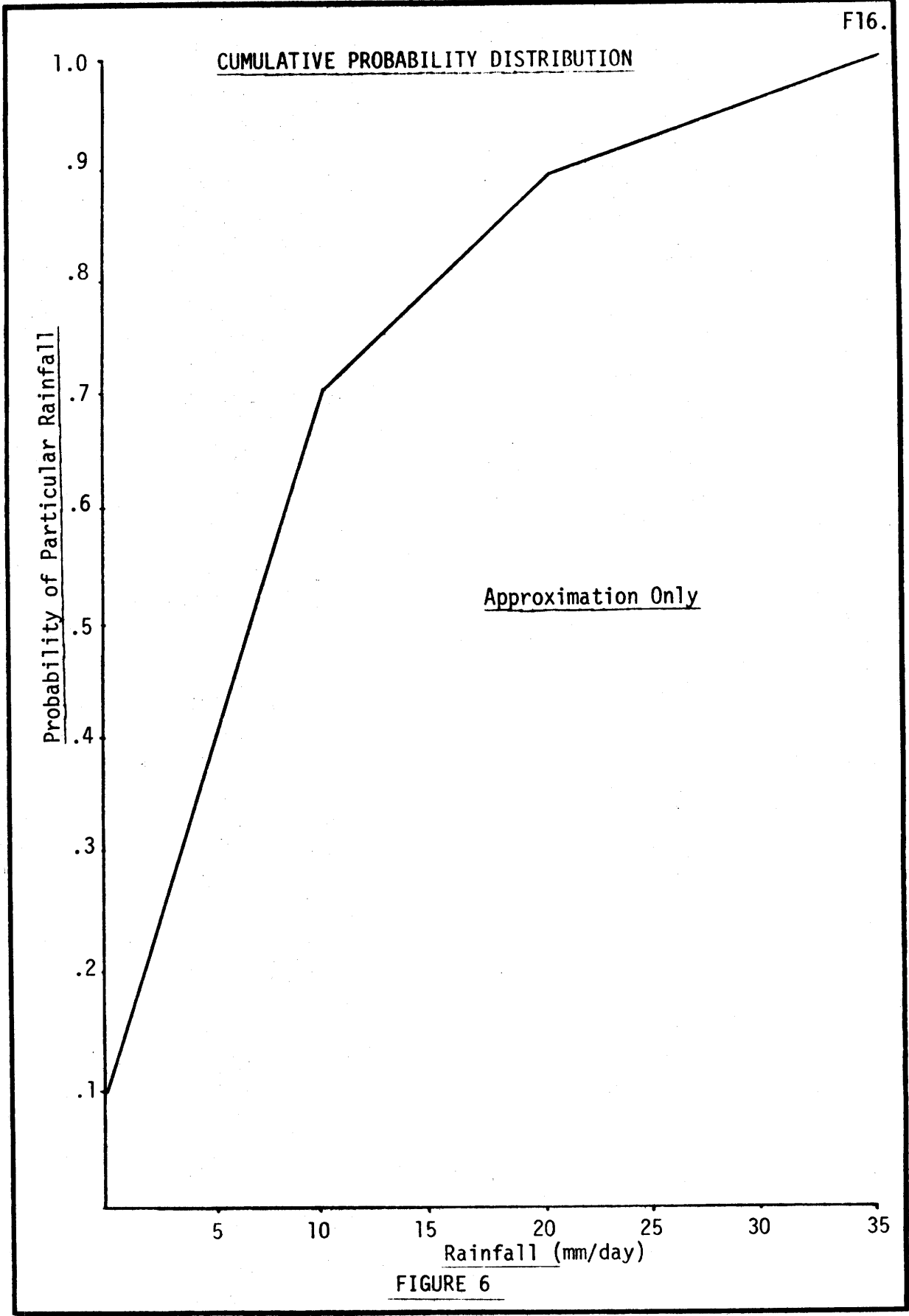

FIGURE 6

From the preceding tables and figure it would be possible to determine the annual rainfall and the monthly rainfall distribution for a particular project. In the case of Ethiopia, however, this is not necessary and it is possible to generalise for a wide area. For most of the zone shown in Figure 5 the heaviest rainfall is during the period June-September, for instance, Gondar 85%, Asmara 80%, Addis Ababa and Gambela 70%, Dire Dawa 60% and Jima 55%. The percentage generally decreases as one moves southward, eg. Moyale 11%, Neghelli and Magalo 20%. It will be assumed that the project lies within the northern-central area and that 80% of the rainfall occurs within the four month rainy season.

Daily rainfall is generally not excessive. Many stations have never recorded as much as 100mm in a day and falls of even 50 mm in 24 hours are unusual. Keren and Nacfa have recorded only two instances each in 27 and 18 years respectively. On the plateau rain can occur every day for long periods. At most stations 50% of the daily falls are less than 4 or 5 mm/day and only 10% (varying from 7 to 20%) are in excess of 20 mm/day.

From the foregoing it is possible to construction the cumulative distribution function for the daily rainfall as shown Figure [6]. From this distribution it is possible, using standard simulation techniques, to generate typical daily rainfalls. In this case only a single simulation will be done using random number tables but it should be borne in mind that for statistically sound results a series of simulation runs should be made using different random number streams. Having determined the rainfall pattern see column 1 Appendix [A] the next problem is to determine how much of that rainfall infiltrates into the pavement structure.

Infiltration.

The amount of infiltration depends upon two factors: the amount of cracking of the sealing surface and the permeability of the underlying pavement layers. From Table [8] it can be seen that a small percentage of cracks can absorb nearly all the precipitation, especially if the precipitation rate is slow.

Runoff Into Surface Cracks PCC Pavements

(precipitation intensity 2 in/hr)

Research by the University of Maryland (lab tests)

<u>Crack Width</u> (in)	<u>Pavement Slope</u> %	<u>Percentage of Runoff</u> <u>Entering Crack</u>
0.035	1.25	70
0.035	2.50	76
0.035	2.75	79
0.050	2.50	89
0.050	3.75	87
0.125	2.50	97
0.125	3.75	95

Table [8]

Reference (1)

In the absence of a better relationship the one depicted in Figure [7] was adopted. It should be noted that AASHO assumed that a pavement

with 84% cracking and patching was totally failed.

F19.

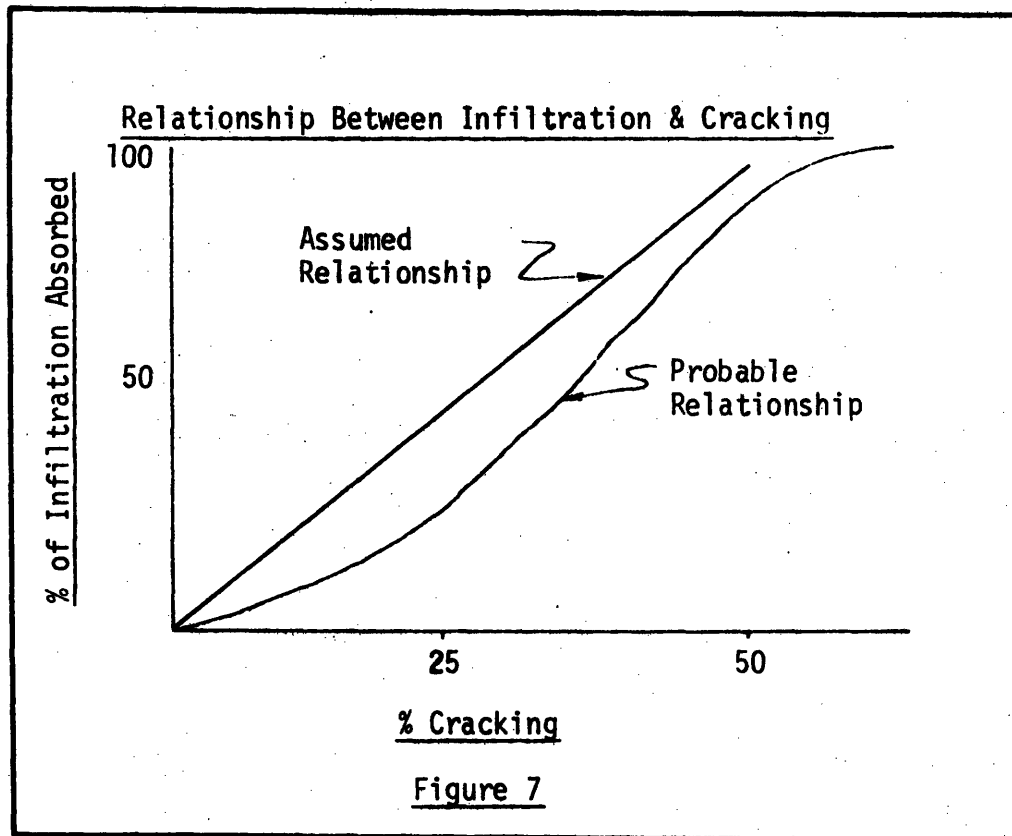

It may be possible to link the amount of infiltration with rut depth as well as cracking and patching, as ruts will allow the water to pond and hence provide a reservoir for the cracks, but this is not possible at this stage. The relationship should be relatively easy to obtain through experimentation with test surfaces and artificial rain.

The total infiltration may be determined by the permeability of the pavement layer. Using the average infiltration rate for dense structured clays (Table [2]) as the minimum likely for pavement materials a rate of 30 mm/day is typical. This value is above the amount that is likely to penetrate a fully cracked pavement during the heaviest storm and so the percentage of cracks governs the infiltration rate.



### Outflows

Using the average coefficient of permeability for "standard" bases and subbases given in Cedergrén [1] pg. 85 of 1 ft/day, the drainage rate is found by flow net Figure [4]. Converting, the possible uniform infiltration that can be handled on a 24-foot pavement is 2.53 mm/day.

Using 0.01 ft/day as the typical coefficient of permeability for compacted subgrades and the flow net shown in Figure [8], the uniform infiltration that can be drained via the subgrade is 1.31 mm/day. It should be noted that much higher rates can be achieved if the water table is deeper (see Table [4]) however, it has been assumed that during the rainy season the water table will be close to the surface and hence the hydraulic gradient will be less.

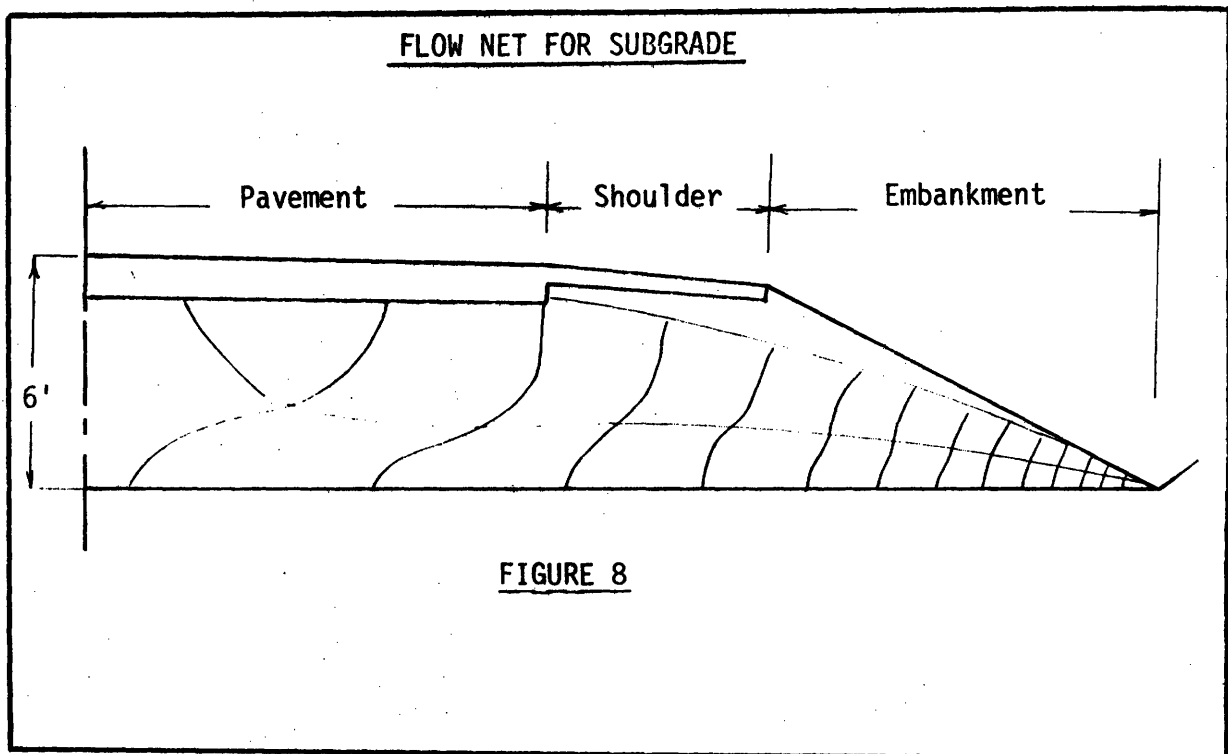

From the preceding results it is possible to estimate the maximum uniform infiltration that can be handled by the cross-sections depicted

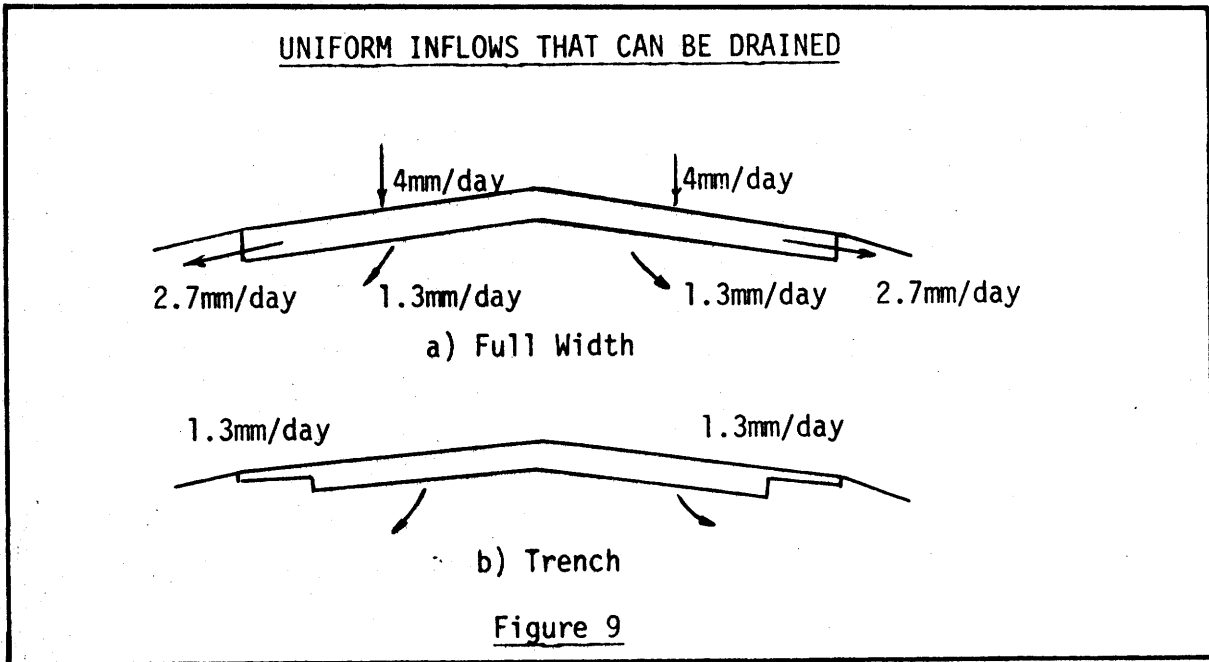

The preceding flow rates only apply when the cross-section is saturated and Darcy's Law hold and hence flows will be less when the pavement is only partially saturated. The relationship adopted between the outflow rates and percentage saturation is shown in Figure [10].

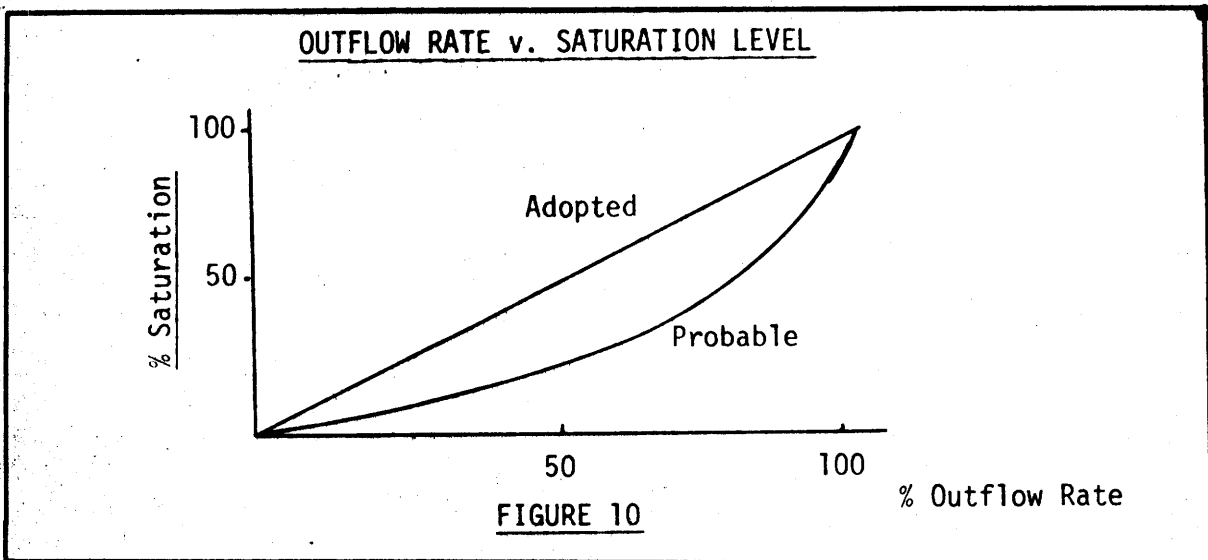

Using 15% as the void ratio typical of most pavement materials it was determined the 45mm of rainfall was required to achieve full saturation of the pavement.

With all the foregoing assumptions it was possible to determine the typical number of days/year that the pavement would be in a saturated condition. See Appendix [A1]. The method used in the calculation is as follows:

Previous excess water(1) + rainfall = Present excess water

Present excess water  $\leq$  45 (ie saturation)

Present excess water  $\div$  = % Saturation = % Outflow rate

Previous excess water (2) = Present excess water - Outflow rate

x % Saturation

### Results

The percentage of days per year saturated versus the percentage of the pavement which is cracked is shown in Figure [11] below.

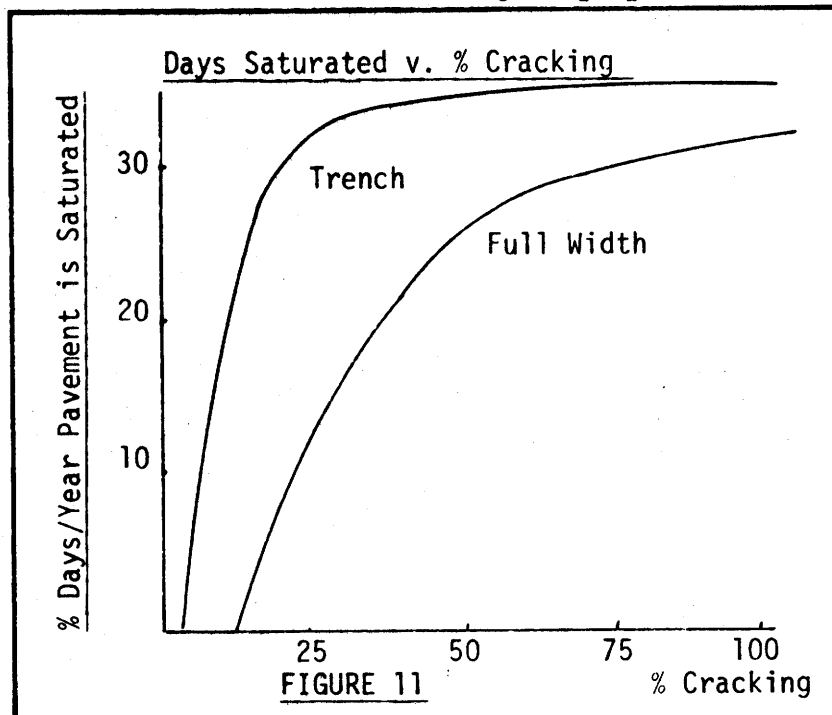

Using the AASHO results with a regional factor of 5 for saturated pavement and 0.2 for dry pavements the average modified structural number can be computed using the same equation as is used now by the HCM.

For example, a 50% cracked full width pavement would have a regional factor of 2.9 whereas if the pavement were 25% cracked the regional factor would be 0.92 and if the pavement were impermeable the regional factor would be 0.2.

#### Summary

Although all the preceding analysis has been based on many assumptions, the method applied is more causal and hence more appealing. Many of the assumptions made would vanish if the methodology were to be applied to a specific case (eg. the permeability of the pavement and the type of construction would be known). Other relationships assumed here, for example the percentage of rainfall which enters the pavement as a function of the pavement condition, could be established by small scale experimentation.

GENERAL RELATIONSHIP BETWEEN RAINFALL AND PAVEMENT CRACKING  
AND REGIONAL FACTOR

Methodology.

As outlined previously, the methodology used to establish the effect of rainfall on pavement performance was to simulate the rainfall for the wet season and then using the inflows into the pavement (taken to be a proportion of the rainfall which depended upon the amount of cracking of the pavement) and the outflows (taken to be lateral and/or subgrade drainage) the number of days per year the pavement was in a saturated condition could be estimated.

This procedure was applied to four different countries--namely Ethiopia, Malawi, Tanzania and Upper Volta. The results are depicted in Figures 11, 12, 13, 14 respectively.

As each of these countries has a different average monthly rainfall and different duration of wet season, it was possible to determine an approximate formula for the percentage number of wet days per year for full width pavements, as shown below.

$$S = \frac{64 R^2}{N} - \frac{64 R^2}{N x / 10}$$

$$S = 0 \quad x < 10$$

R - Yearly rainfall in metres.

N - Number of wet months in rainy season.

x - % cracking of pavement

[N.B.: It is assumed 80% of annual rainfall occurs in the rainy season.]

Then based on the assumption that when a pavement is saturated the corresponding regional factor is 5 and when the pavement is dry the

appropriate regional factor is 0.2

The weighted regional factor is then simply

$$RF = S \times 5 + (1-S)0.2.$$

Conclusion.

It should be noted that equations outlined here are very approximate; however, the methodology is sound and it allows greater policy sensitivity. The methodology at present in the AASHO based model is to simply take the regional factor as the rainfall in metres regardless of the condition of the surfacing, and this has tended to yield rapid deterioration rates when compared to the TRRL model. It is intuitive that the pavement strength and hence pavement life should depend upon the amount of rainfall which actually enters the pavement structure and that the prevention of this ingress is the purpose of bituminous surfacing and the maintenance of same. As well as having a better basis the new relationship requires no more data than is presently input into the H.C.M.

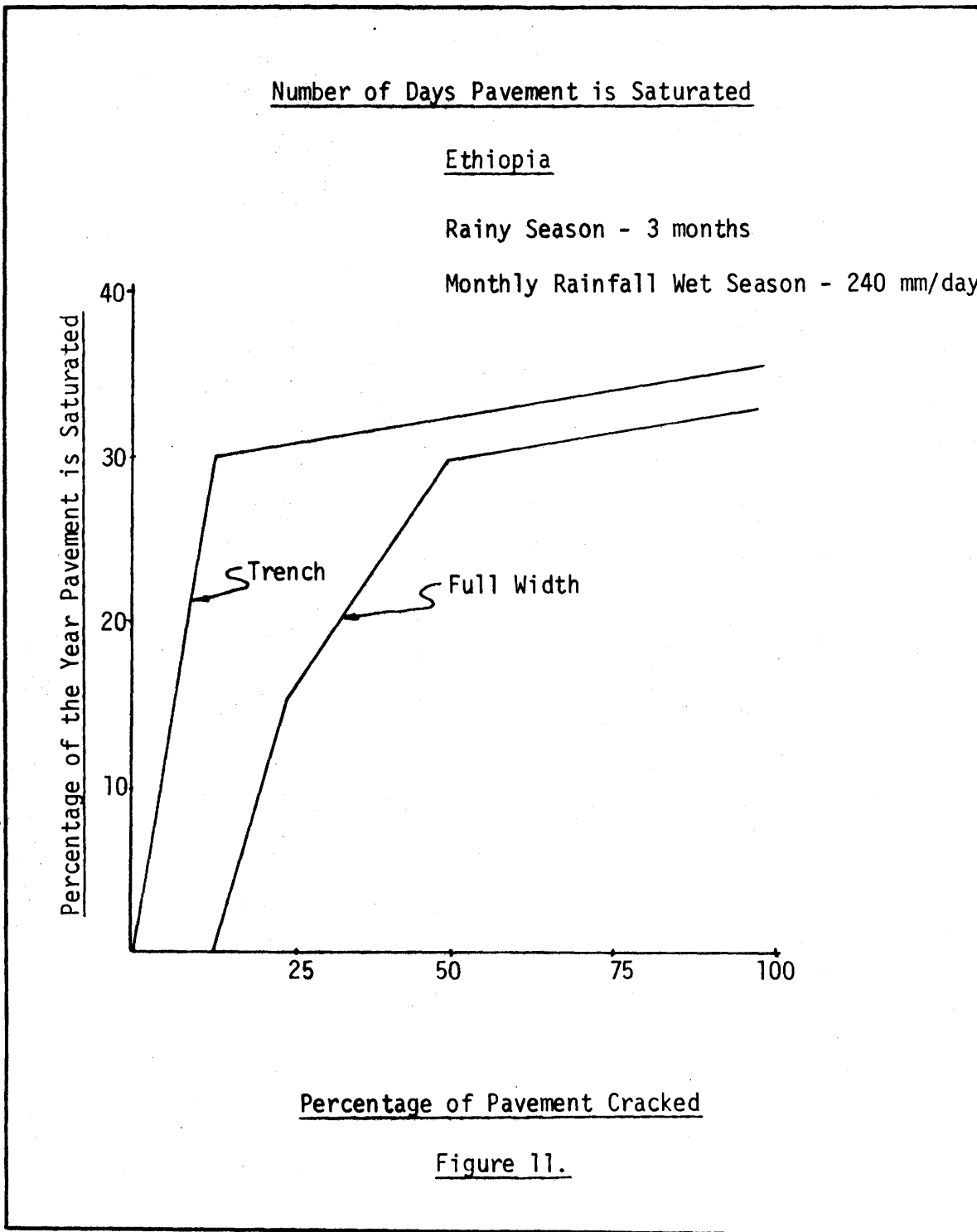

NUMBER OF DAYS PAVEMENT IS SATURATED

Malawi

Rainy Season - 4 months

Monthly Rainfall Wet Season - 200mm/day

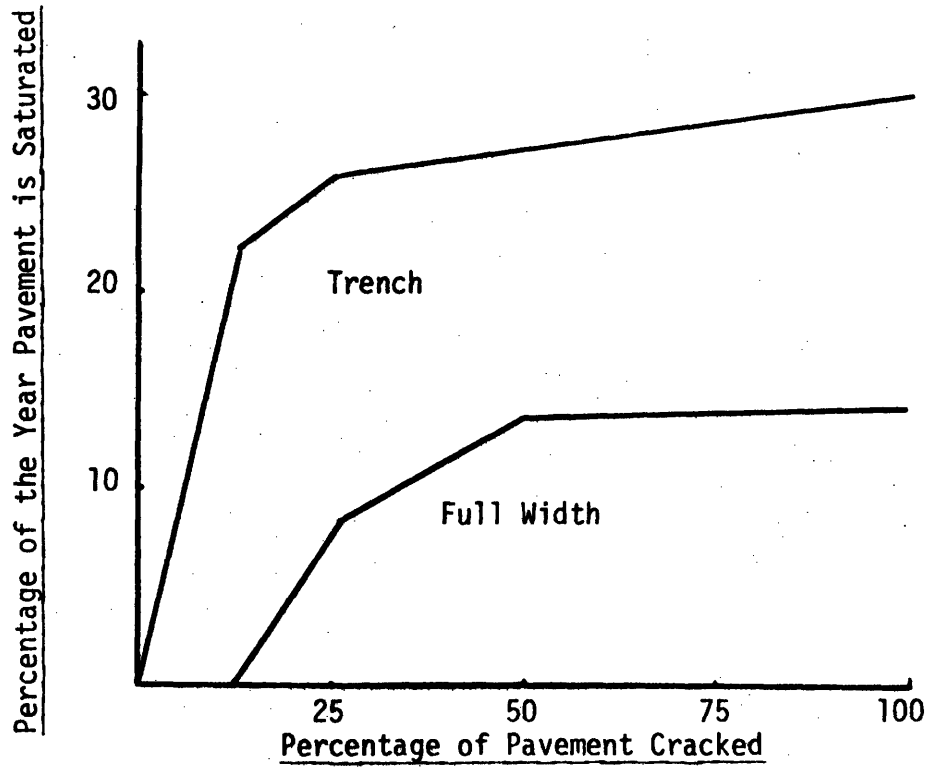

FIGURE 12



NUMBERS OF DAYS PAVEMENT IS SATURATED

Tanzania

Rainy Season - 6 months

Monthly Rainfall Wet Season - 150mm/day

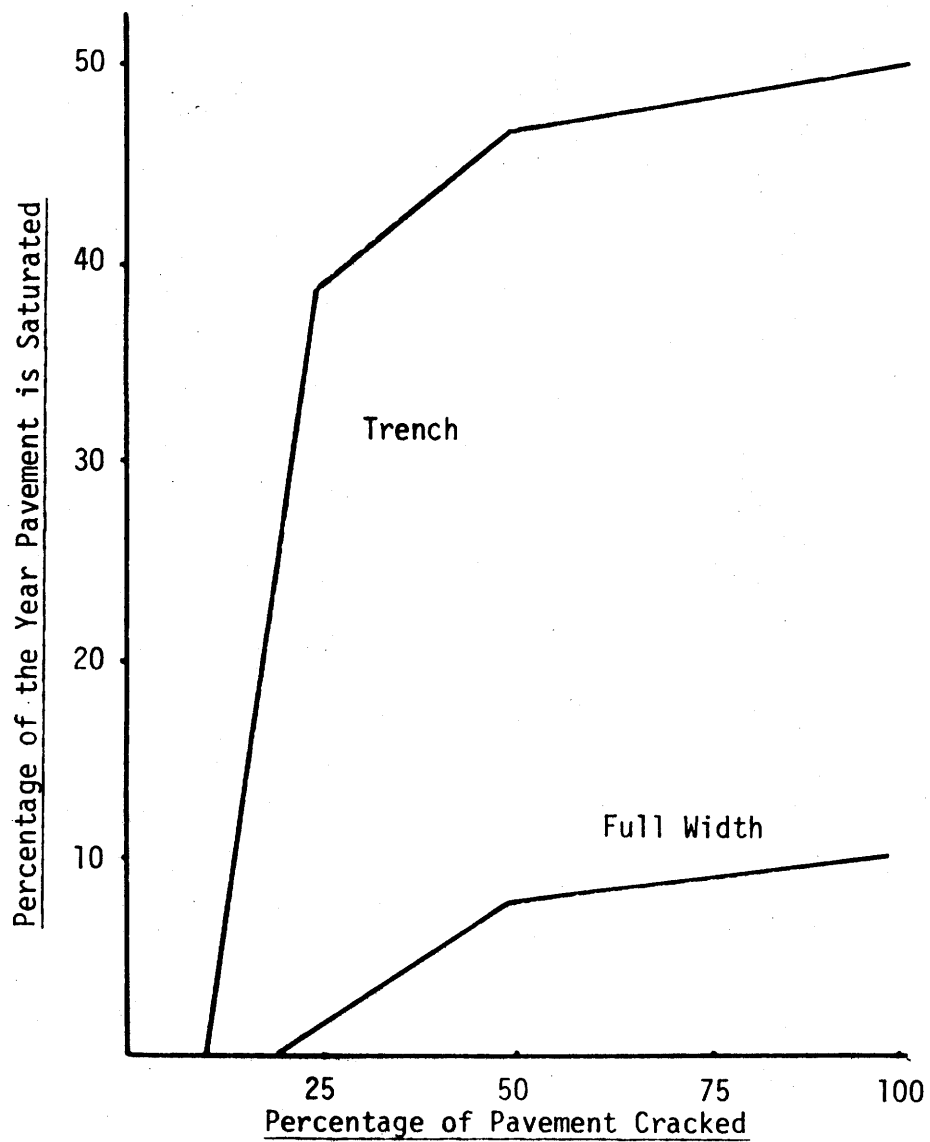

FIGURE 13

NUMBER OF DAYS PAVEMENT IS SATURATED

Upper Volta

Rainy Season - 3 months

Monthly Rainfall Wet Season - 250mm/day

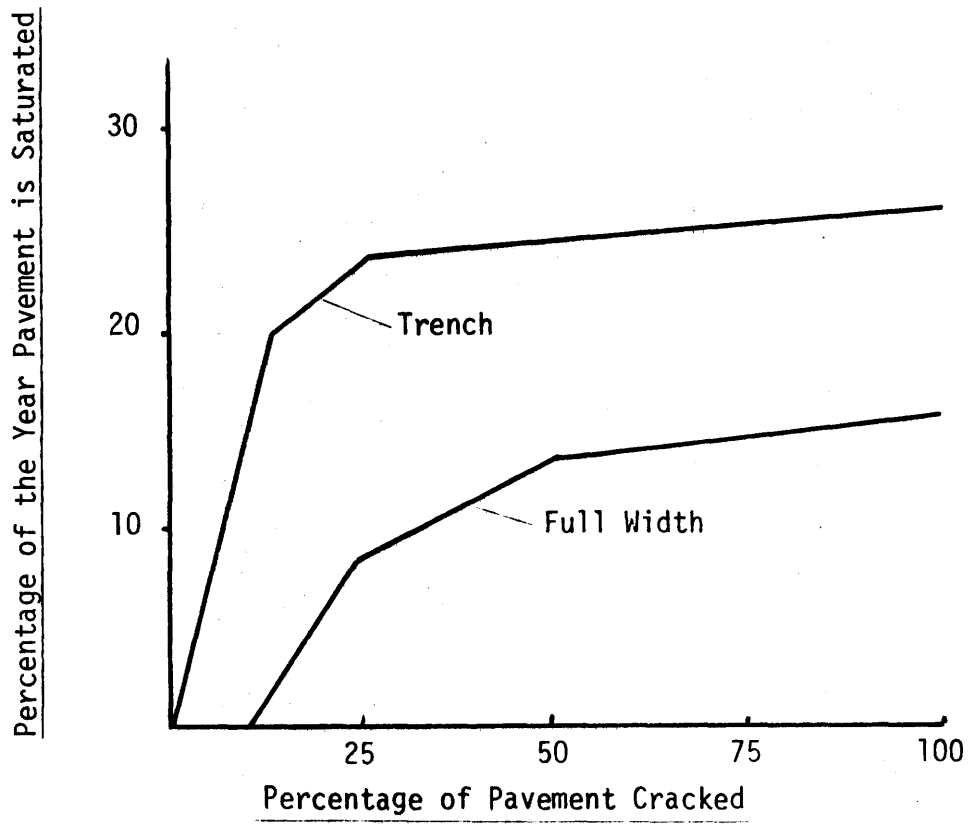

FIGURE 14

References.

- 1) Cedergren, H. R., Drainage of Highway and Airfield Pavements, John Wiley and Sons, 1974.
- 2) Cedergren, H. R., Seepage, Drainage and Flow Nets, John Wiley and Sons, 1968.
- 3) Yong, R. N. and Warkentin, B. P., Introduction to Soil Behavior, MacMillan, 1966.
- 4) Krebs, R. D. and Walker, R. D., Highway Materials, McGraw-Hill Inc., 1971.
- 5) Aitchison, G. D., Editor, Moisture Equilibria and Moisture Changes in Soils Beneath Covered Areas, (A Symposium in Print), Butterworths Aust., 1965.
- 6) Chow, V. T., Handbook of Applied Hydrology, McGraw-Hill Inc., 1964.
- 7) AASHTO Interim Guide for Design of Pavement Structures 1972, ASSHTO Publications, 1974.
- 8) Landsberg, Editor, World Survey of Climatology, Vol. 10, Climates of Africa, Elsevier Publishing Co., 1972.
- 9) Lebeder, A. N., Editor, The Climate of Africa, Part 1, Air-Temperature and Precipitation, U.S. Dept. of Commerce, 1968.

APPENDIX A1

SIMULATION OF PAVEMENT DRAINAGE.

Day	Rainfall	FULL WIDTH						TRENCH					
		50% Cracked		25% Cracked		12% Cracked		50% cracked		25% Cracked		12% Cracked	
		Outflow	WC	Outflow	WC	Outflow	WC	Outflow	WC	Outflow	WC	Outflow	WC
1	6	-	6	-	3	-	2	-	3	-	2	-	1
2	0	1	5	-	3	-	1	-	3	-	2	-	1
3	6	1	10	1	5	-	2	-	6	-	3	-	2
4	7	2	15	1	7	-	4	-	9	-	5	-	3
5	0	1	16	1	6	1	3	-	9	-	5	-	3
6	9	2	23	1	9	-	5	1	12	-	7	-	4
7	9	3	29	1	12	-	7	-	16	-	9	-	5
8	1	3	27	1	12	-	6	-	16	1	8	-	5
9	2	3	26	1	12	-	6	-	17	-	-	-	5
10	8	3	31	1	15	1	7	1	20	-	10	-	6
11	2	3	30	1	15	-	7	-	21	-	10	-	6
12	29	4	45	2	28	1	13	1	36	-	16	-	9
13	7	4	45	2	30	1	14	1	40	1	17	-	10
14	3	4	45	2	29	1	14	1	41	-	18	-	10
15	10	4	45	2	32	1	15	1	45	-	20	-	11
16	4	4	45	3	31	1	15	1	45	-	21	-	11
17	7	4	45	3	31	1	16	1	45	1	22	-	12
18	8	4	45	3	32	1	17	1	45	-	24	-	13
19	4	4	45	3	31	1	17	1	45	1	24	-	13
20	35	4	45	3	45	1	25	1	45	-	33	-	16
21	1	4	42	4	41	2	23	1	45	1	32	-	16
22	34	4	45	4	45	2	29	1	45	1	39	-	19
23	etc	4	45	4	43	2	28	1	45	1	39	1	18
24	26	4	45	4	45	2	34	1	45	1	44	-	21
25	9	4	45	4	45	3	33	1	45	1	45	-	22
26	8	4	45	4	45	3	32	1	45	1	45	-	23
27	6	4	45	4	44	3	30	1	45	1	45	-	24
28	4	4	45	4	42	2	29	1	45	1	45	-	25
29	6	4	45	4	41	2	28	1	45	1	45	-	25
30	2	4	45	4	38	2	26	1	45	1	45	1	24
31	4	4	45	4	36	2	25	1	45	1	45	-	24
32	15	4	45	4	40	2	27	1	45	1	45	-	26
33	1	4	42	4	36	2	25	1	45	1	44	1	25

Day Rainfall

	Day Rainfall		FULL WIDTH						TRENCH					
			50% Cracked		25% Cracked		12% Cracked		50% Cracked		25% Cracked		12% Cracked	
			Outflow	WC	Outflow	WC	Outflow	WC	Outflow	WC	Outflow	WC	Outflow	WC
34	4	4	42	3	35	2	24	1	45	1	44	-	25	
35	17	4	42	3	40	2	26	1	45	1	45	1	26	
36	9	4	45	4	40	2	26	1	45	1	45	-	27	
37	9	4	45	4	40	2	26	1	45	1	45	-	28	
38	4	4	45	4	38	2	25	1	45	1	45	-	28	
39	8	4	45	4	38	2		1	45	1	45	-	29	
40	1	4	42	4	35	2	23	1	45	1	44	1	28	
41	0	4	38	3	32	2	21	1	45	1	43	-	28	
42	2	4	36	3	30	2	20	1	45	1	42	-	28	
43	9	4	42	3	32	2	20	1	45	1	43	1	28	
44	18	4	45	3	38	2	22	1	45	1	45	-	30	
45	4	4	45	4	36	2	21	1	45	1	45	-	30	
46	5	4	45	3	35	2	19	1	45	1	45	-	30	
47	6	4	45	3	35	2	17	1	45	1	45	-	30	
48	4	4	45	3	35	2	15	1	45	1	45	-	30	
49	3	4	44	3	32	1	15	1	45	1	45	-	30	
50	0	4	40	3	29	1	14	1	45	1	44	-	30	
51	17	4	45	3	34	1	17	1	45	1	45	-	32	
52	22	4	45	3	42	1	21	1	45	1	45	1	33	
53	12	4	45	4	44	2	22	1	45	1	45	-	34	
54	4	4	45	4	42	2	21	1	45	1	45	-	34	
55	7	4	45	4	42	2	21	1	45	1	45	1	34	
56	30	4	45	4	45	2	27	1	45	1	45	-	37	
57	17	4	45	4	45	3	28	1	45	1	45	1	38	
58	8	4	45	2	28	1	45	1	45	1	38	1	38	
59	0	4	41	4	41	2	25	1	45	1	44	1	37	
60	14	4	45	4	44	2	28	1	45	1	45	1	38	
61	5	4	45	4	42	3	26	1	45	1	45	1	37	
62	3	4	44	4	39	2	25	1	45	1	45	1	36	
63	10	4	45	4	40	2	25	1	45	1	45	1	36	
64	10	4	45	4	41	2	25	1	45	1	45	1	36	
65	0	4	41	4	37	2	23	1	45	1	44	1	35	
66	22	4	45	4	42	2	25	1	45	1	45	1	36	

Day	Rainfall	FULL WIDTH						TRENCH					
		50% Cracked		25% Cracked		12% Cracked		50% Cracked		25% Cracked		12% Cracked	
		Outflow	WC	Outflow	WC	Outflow	WC	Outflow	WC	Outflow	WC	Outflow	WC
67	2	4	43	4	39	2	23	1	45	1	44	1	35
68	10	4	45	4	40	2	23	1	45	1	45	1	35
69	8	4	45	4	40	2	23	1	45	1	45	1	35
70	30	4	45	4	45	2	29	1	45	1	45	1	37
71	20	4	45	4	45	3	31	1	45	1	45	1	38
72	0	4	41	4	41	3	27	1	45	1	44	1	37
73	12	4	45	4	43	3	27	1	45	1	45	1	37
74	12	4	45	5	45	3	27	1	45	1	45	1	37
75	6	4	45	4	44	3	26	1	45	1	45	1	37
76	8	4	45	4	44	2	26	1	45	1	45	1	37
77	9	4	45	4	45	2	26	1	45	1	45	1	37
78	9	4	45	4	45	2	26	1	45	1	45	1	37
79	0	4	41	4	41	2	24	1	45	1	45	1	36
80	22	4	45	4	45	2	27	1	45	1	45	1	37
81	16	4	45	4	45	3	28	1	45	1	45	1	38
82	5	4	45	4	42	3	26	1	45	1	45	1	37
83	19	4	45	4	45	2	29	1	45	1	45	1	38
84	7	4	45	4	44	3	28	1	45	1	45	1	38
85	20	4	45	4	45	3	30	1	45	1	45	1	39
86	5	4	45	4	43	3	28	1	45	1	45	1	39
87	34	4	45	4	45	3	33	1	45	1	45	1	41
88	18	4	45	4	45	3	35	1	45	1	45	1	42
89	0	4	41	4	41	3	32	1	45	1	44	1	41
90	1	4	38	4	37	3	29	1	45	1	43	1	40
91	11	4	45	4	38	3	29	1	45	1	45	1	40
92	0	4	41	4	32	3	26	1	45	1	44	1	39
93	17	4	45	3	37	2	28	1	45	1	45	1	40
94	2	4	43	4	34	2	26	1	45	1	44	1	39
95	2	4	43	4	34	2	26	1	45	1	44	1	39
96	7	4	41	3	31	2	24	1	45	1	44	1	38
97	4	4	45	4	40	3	27	1	45	1	45	1	40
98	4	4	45	4	40	3	27	1	45	1	45	1	39
99	30	4	45	4	45	3	32	1	45	1	45	1	41

Day Rainfall

			FULL WIDTH						TRENCH					
			50% Cracked		25% Cracked		12% Cracked		50% Cracked		25% Cracked		12% Cracked	
			Outflow	WC	Outflow	WC	Outflow	WC	Outflow	WC	Outflow	WC	Outflow	WC
100	6	4	45	4	44	3	30	1	45	1	45	1	41	
101	28	4	45	4	45	3	34	1	45	1	45	1	43	
102	18	4	45	4	45	3	36	1	45	1	45	1	44	
103	23	4	45	4	45	3	39	1	45	1	45	1	45	
104	8	4	45	4	45	4	37	1	45	1	45	1	45	
105	15	4	45	4	45	3	38	1	45	1	45	1	45	
106	0	4	41	4	41	3	35	1	45	1	45	1	44	
107	0	4	37	4	37	3	32	1	45	1	44	1	43	
108	5	4	38	4	35	3	30	1	45	1	43	1	42	
109	20	4	45	4	41	3	32	1	45	1	43	1	43	
110	6	4	45	4	40	3	30	1	45	1	45	1	43	
111	3	4	44	4	38	3	28	1	45	1	45	1	42	
112	5	4	45	4	36	2	27	1	45	1	45	1	41	
113	4	4	45	3	35	2	26	1	45	1	45	1	40	
114	9	4	45	3	36	2	26	1	45	1	45	1	40	
115	3	4	44	3	34	2	25	1	45	1	45	1	39	
116	5	4	45	3	34	2	24	1	45	1	45	1	38	
117	0	4	42	3	31	2	22	1	45	1	44	1	37	
118	11	4	45	3	34	2	23	1	45	1	45	1	37	
119	4	4	45	3	32	2	22	1	45	1	45	1	36	
120	3	4	44	3	31	2	21	1	45	1	45	1	35	
121		4	40	3	29	2	19	1	44	1	44			
122		4	36	2	27	2	17	1	43	1	43			
123		3	33	2	25	2		1	42	1	42			
124		3	30	2	23			1	41	1	41			
125		3	27	2	21			1	40	1	40			
126		2	25	2	19			1	39	1	39			
127		2	23					1	38	1	38			
128		2	21					1	37					
129		2	19					1	36					
130		2	17					1	35					



APPENDIX G  
TOTAL DISCOUNTED COSTS FOR VARIOUS PAVEMENT  
STRENGTHS AND MAINTENANCE POLICIES

TOTAL DISCOUNTED COSTS FOR VARIOUS PAVEMENT STRENGTHS AND MAINTENANCE POLICIES

Traffic 200 ADT  
0 % growth

 Vehicle Operating Costs  
 Incremental Construction  
 Maintenance Costs

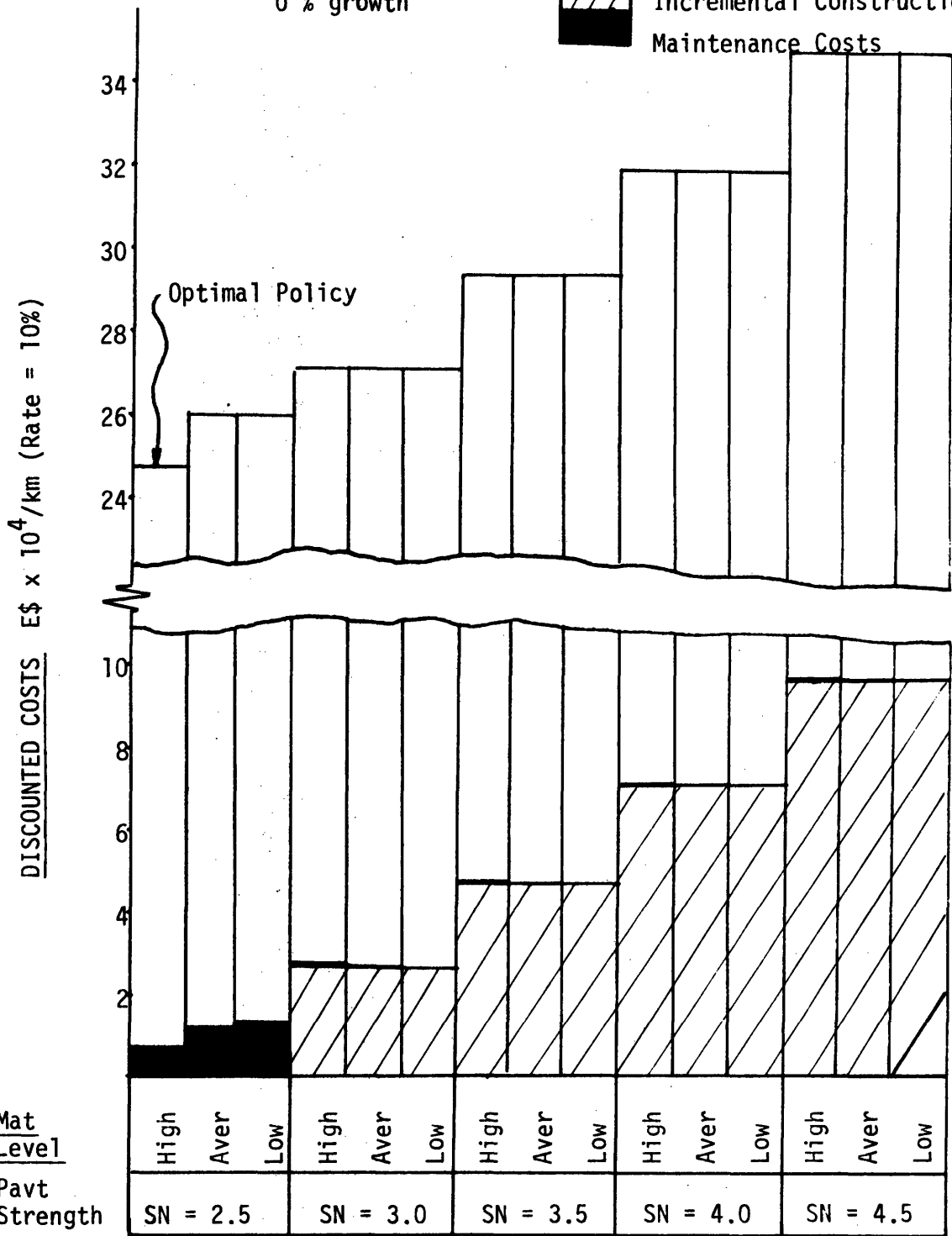

FIGURE G1

**TOTAL DISCOUNTED COSTS FOR VARIOUS PAVEMENT STRENGTHS AND MAINTENANCE POLICIES**

G2.

Traffic 200 ADT  
5% growth

Vehicle Operating Costs  
 Incremental Const. Costs  
 Maintenance Costs

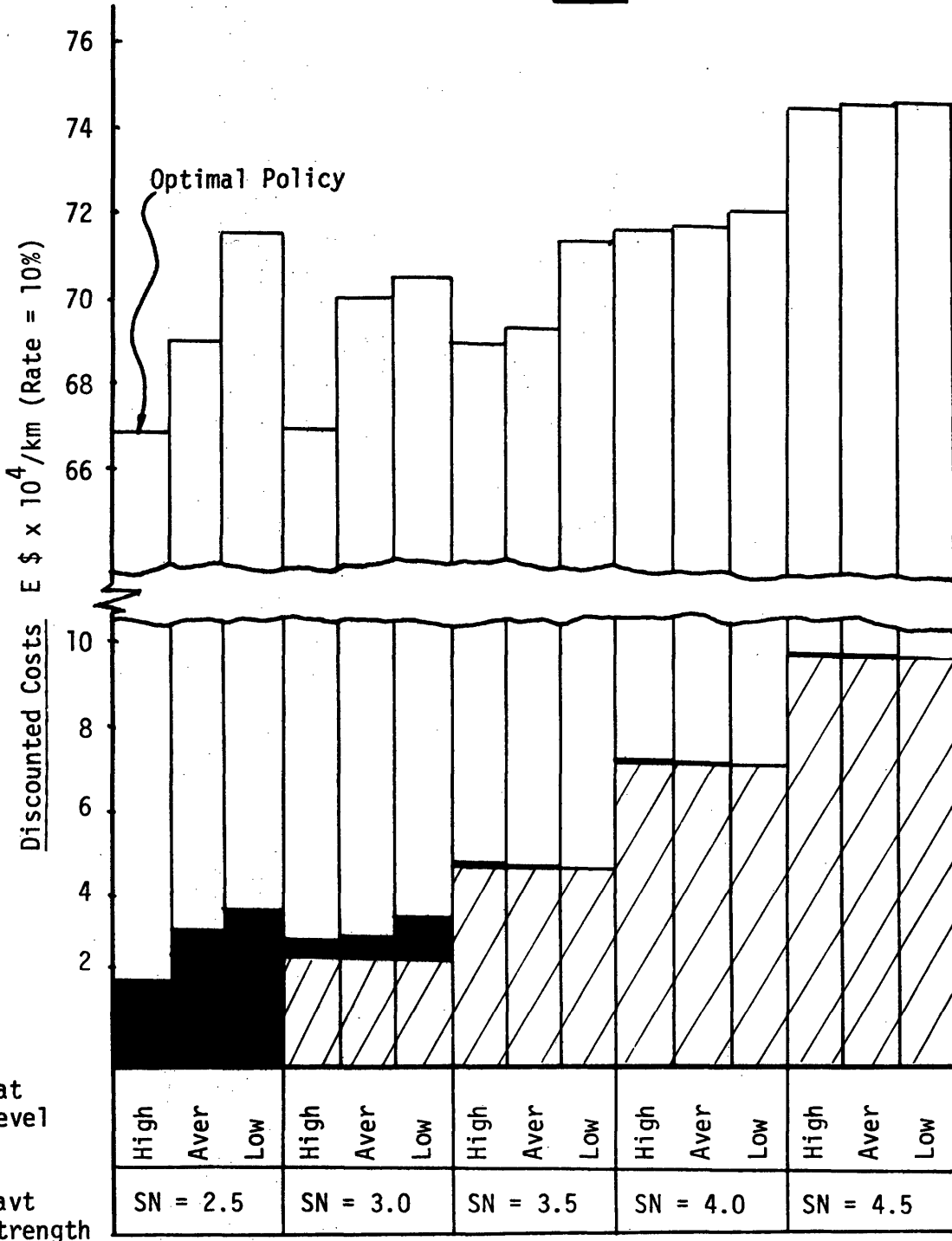

FIGURE G 2

TOTAL DISCOUNTED COSTS FOR VARIOUS PAVEMENT STRENGTHS AND MAINTENANCE POLICIES G3.

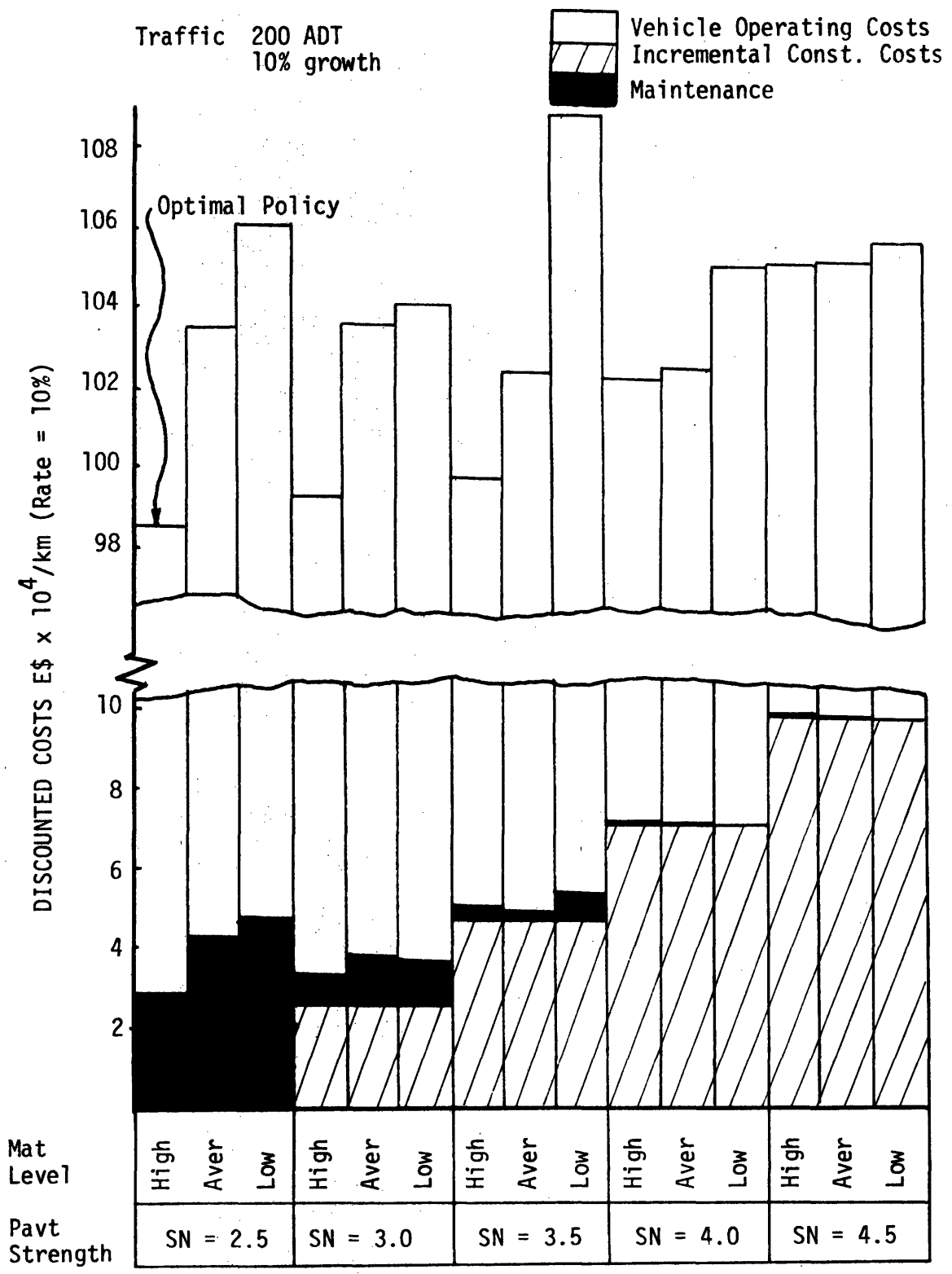

FIGURE G 3

TOTAL DISCOUNTED COSTS FOR VARIOUS PAVEMENT STRENGTHS AND MAINTENANCE POLICIES G4.

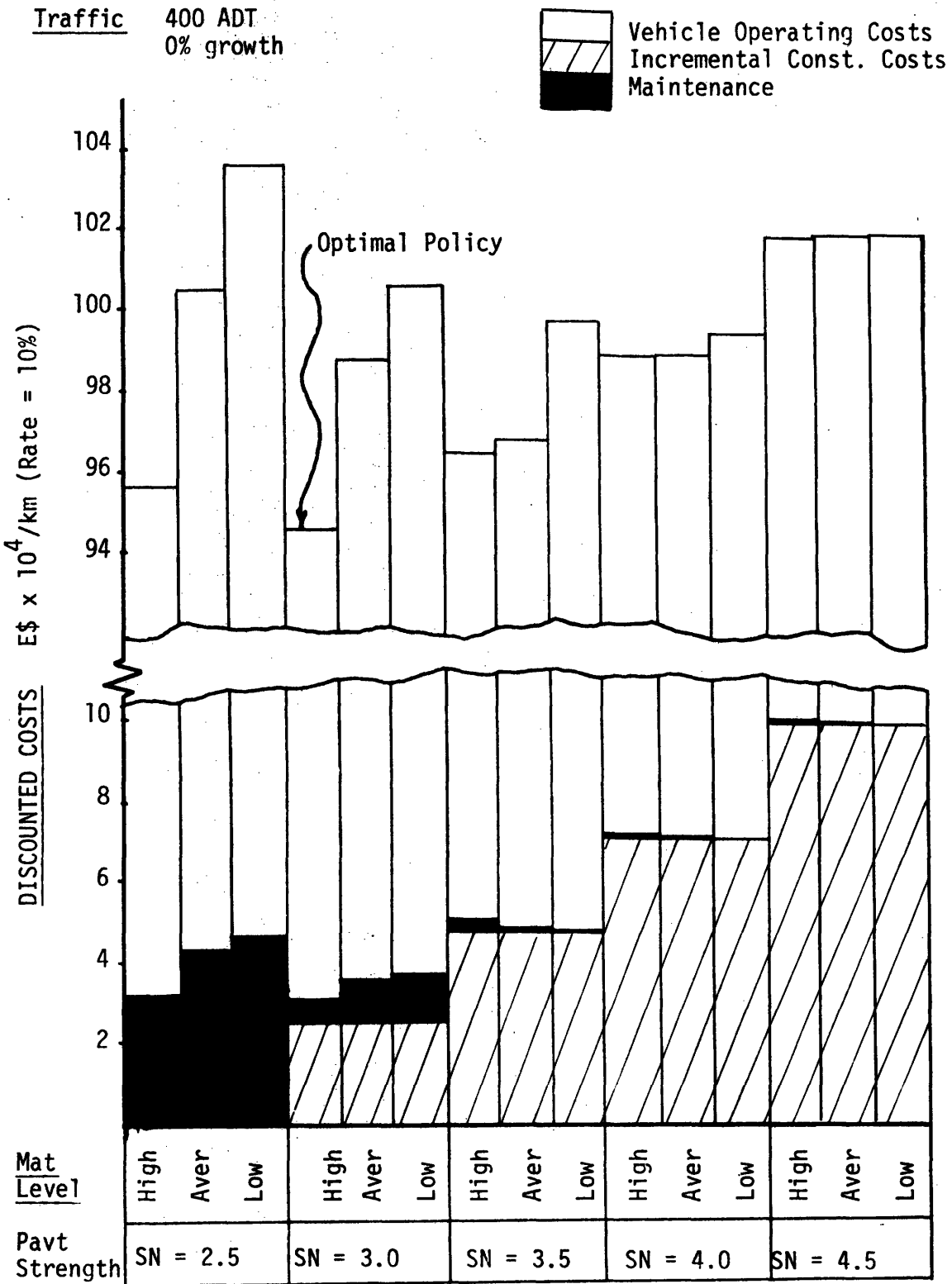



FIGURE G 4

**TOTAL DISCOUNTED COSTS FOR VARIOUS PAVEMENT STRENGTHS AND MAINTENANCE POLICIES**

Traffic 400 ADT  
5 % growth

 Vehicle Operating Costs  
 Incremental Const. Costs  
 Maintenance Costs

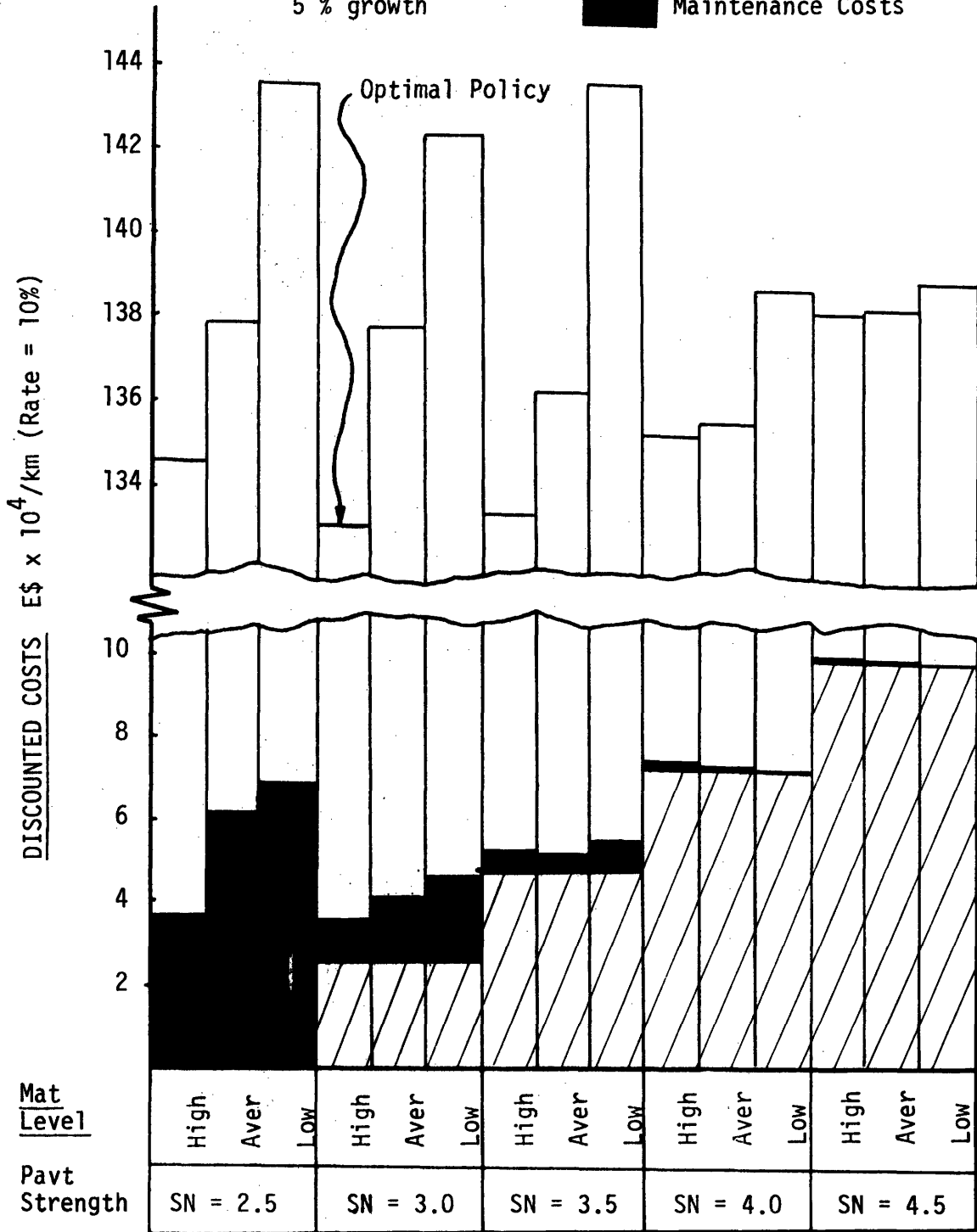

FIGURE G 5

TOTAL DISCOUNTED COSTS FOR VARIOUS PAVEMENT STRENGTHS AND MAINTENANCE POLICIES

G6.

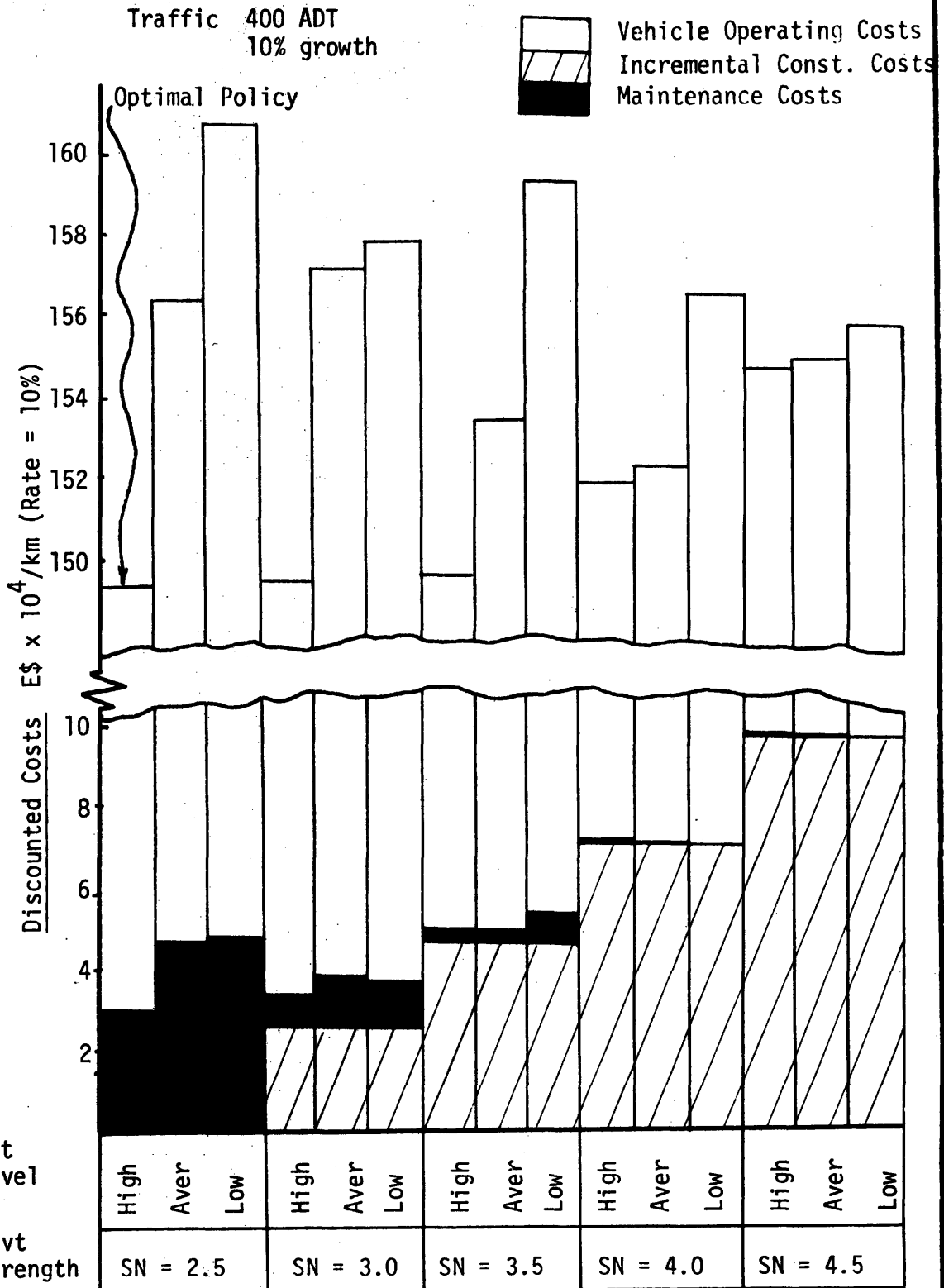

FIGURE G 6

**TOTAL DISCOUNTED COSTS FOR VARIOUS PAVEMENT STRATEGIES AND MAINTENANCE POLICIES**

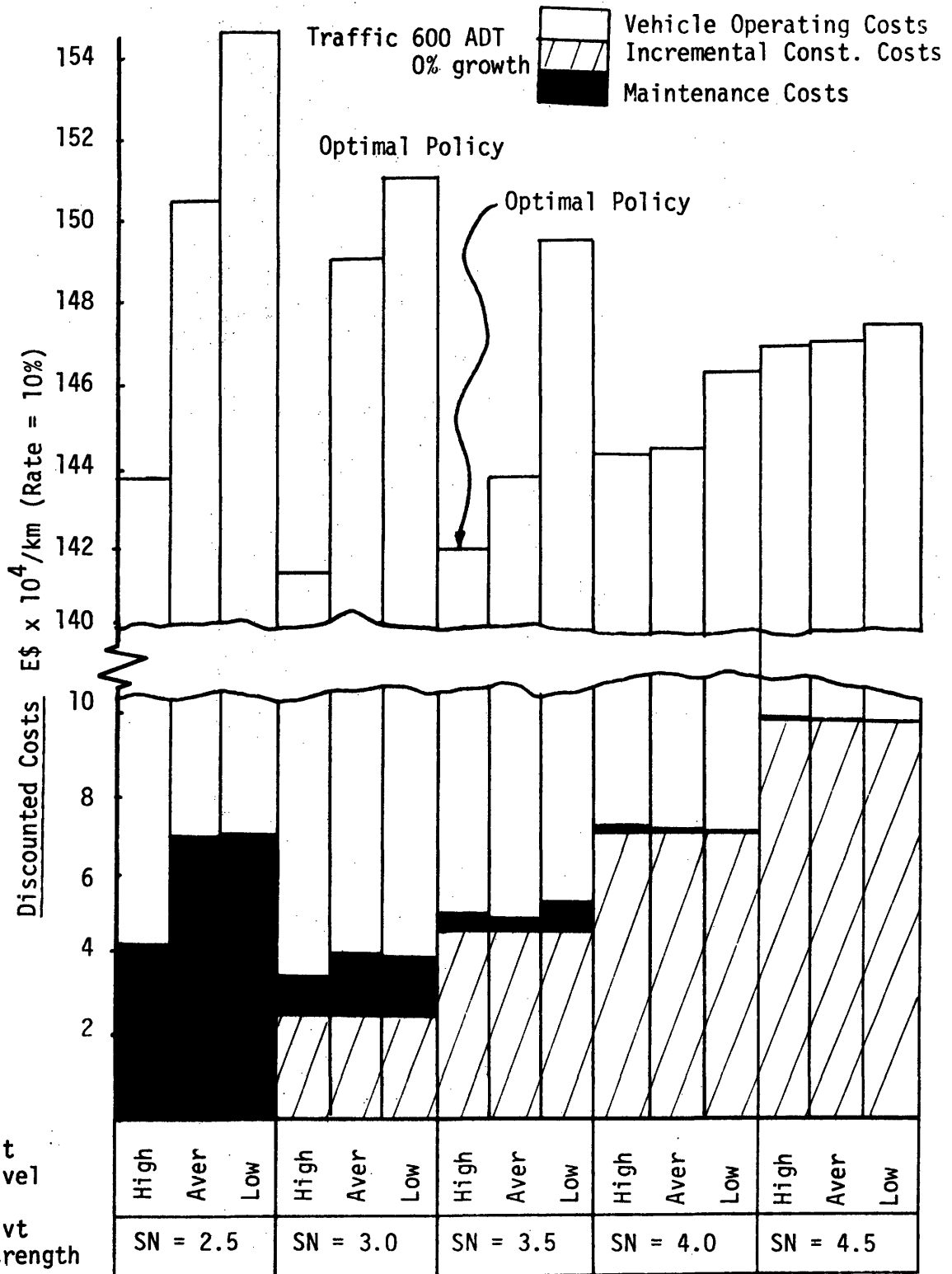

FIGURE G 7



TOTAL DISCOUNTED COSTS FOR VARIOUS PAVEMENT STRENGTHS AND MAINTENANCE POLICIES

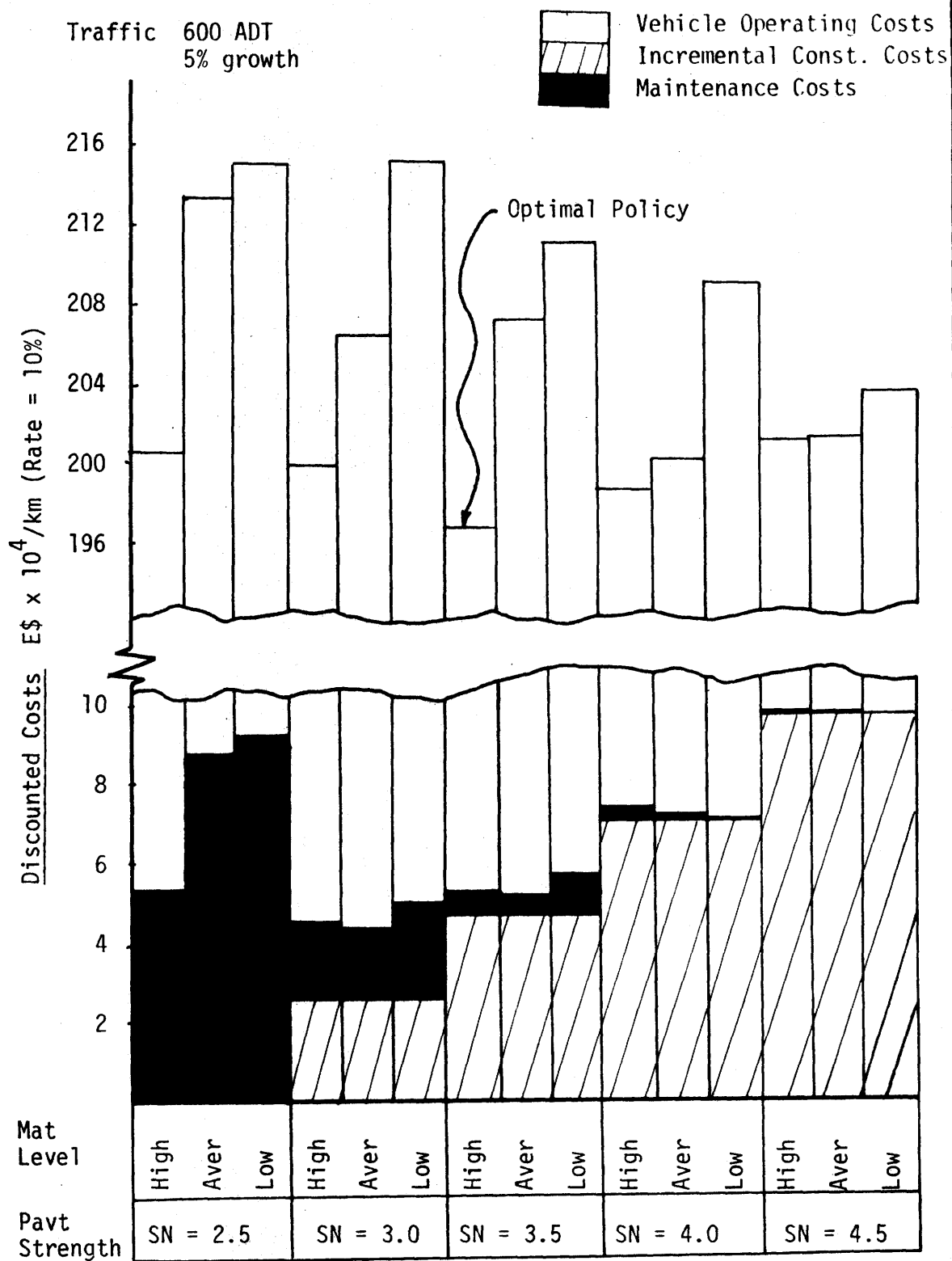



FIGURE G8

TOTAL DISCOUNTED COSTS FOR VARIOUS PAVEMENT STRENGTHS AND MAINTENANCE POLICIES

G9.

Traffic 600 ADT  
10% growth

 Vehicle Operating Costs  
 Incremental Const. Costs  
 Maintenance Costs

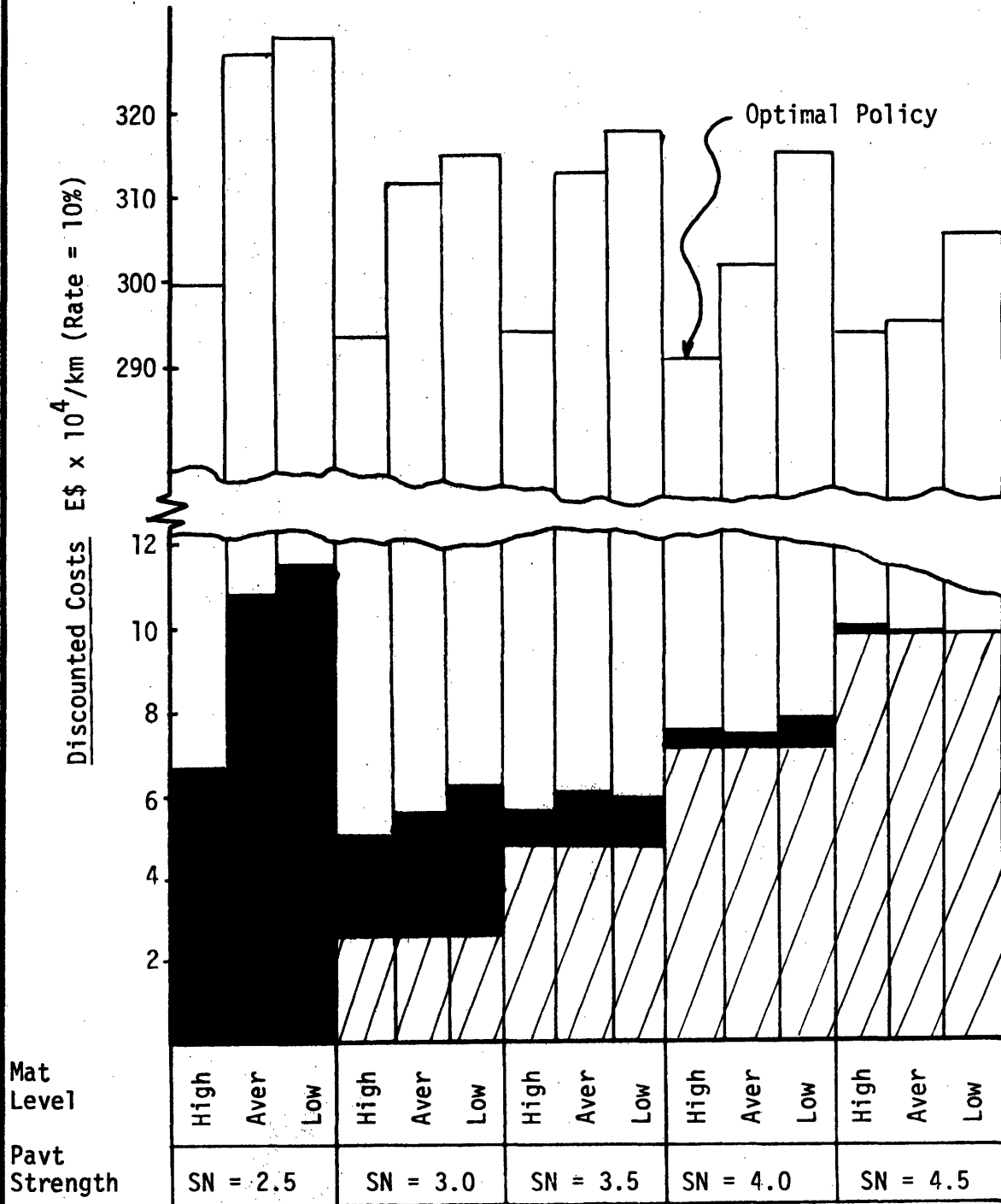

FIGURE G 9

APPENDIX H

MAINTENANCE POLICIES

MAINTENANCE UNIT COSTS

MAINTENANCE POLICIESINTENSIVE MAINTENANCE

BIT-SURFACE PATCHING	100% cracks filled
BIT-SEAL COATING	15% max cracking
BIT-OVERLAY	4000 max roughness

AVERAGE MAINTENANCE

BIT-SURFACE PATCHING	50% cracks filled
BIT-SEAL COATING	50% max cracking
BIT-OVERLAY	6000 max roughness

NIL MAINTENANCE

BIT-SURFACE PATCHING	1% cracks filled
BIT-SEAL COATING	100% max cracking
BIT-OVERLAY	8000 max roughness

MAINTENANCE COSTS

Description	Units	Skilled	Unskilled	Equipment	Material	Overhead	Total
B-Surf Patching	M2	0.31	0.27	3.00	2.66	1.32	7.56
Bit Seal Coating	M2	0.04	0.0	0.27	0.45	0.16	0.92
Bit Overlay	M3	4.20	0.0	18.37	96.60	25.14	144.31

NB Costs are in Ethiopian dollars.