

ON THE NATURE OF TONE

by

Zhiming Bao

Submitted to the Department of
Linguistics and Philosophy
in Partial Fulfillment of the Requirements
for the Degree of

DOCTOR OF PHILOSOPHY

at the

MASSACHUSETTS INSTITUTE OF TECHNOLOGY

June 1990

© Zhiming Bao, 1990

The author hereby grants to M.I.T. permission to reproduce
and to distribute copies of this thesis document in whole or
in part.

Signature of Author _____
Department of Linguistics and Philosophy
May 21, 1990

Certified by _____
Professor Morris Halle
Thesis Supervisor

Accepted by _____
Professor Wayne O'Neil
Chair, Departmental Committee

ARCHIVES
MASSACHUSETTS INSTITUTE
OF TECHNOLOGY

JUN 12 1990

LIBRARIES

Abstract

This thesis addresses two issues: the feature geometry of tone; and the formal relation of tone with respect to other aspects of phonological representation.

The tonal geometry I propose can be stated simply: tone (t) consists of register (r) and contour (c):



r is specified by the laryngeal feature [stiff], and c by the laryngeal feature [slack]. In addition, c is allowed to branch. The structures of r and c are in (2).

Since tone is phonetically executed by the VC node, it is claimed that the geometry of tone is a substructure of the geometry of laryngeal features. The geometry of laryngeal features is shown in (3) (CT=cricothyroid; VOC=vocalis):

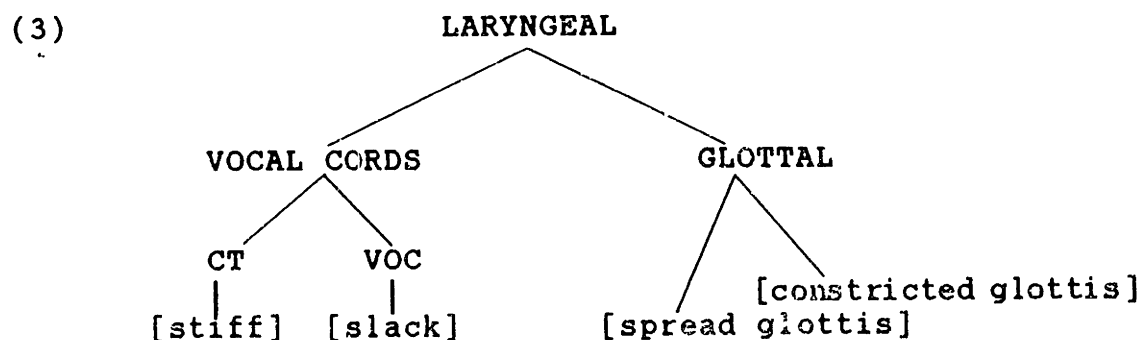

It is speculated that register is executed by the articulator CT; and contour by the articulator VOC over time.

I argue against a tone plane. The mapping of tones to tone bearing units (TBU) is an adjunction process: tone is adjoined to the tone bearing unit. Given that the rime is the TBU, tone mapping creates the structure below:



Thus, tones form a tier on the syllable plane, rather than an independent plane. This accounts for structure-dependency of tone stability.

After tone sandhi rules have applied, t is linked to the laryngeal node of the head of TBU through the process of segmentalization. This allows tone to be phonetically realized on vowels or other segments which may be the head of tone bearing units.

Acknowledgement

Many people have helped me through the years at MIT, and I want to thank them all. In particular, the following: Matt Alexander, Lisa Cheng, Noam Chomsky, Chris Collins, Francois Dell, Viviane Deprez, Duanmu San, Alicja Gorecka, Ken Hale, Morris Halle, Lori Holmes, Jim Harris, Jim Higginbotham, Kyle Johnson, Myung-Yoon Kang, Richard Kayne, Michael Kenstowicz, Jay Keyser, Richard Larson, Harry Leder, Li Yafei, Janis Melvold, Scott Meredith, Wayne O'Neil, David Petsesky, Luigi Rizzi, Brian Sietsema, Kelly Sloan, Donca Steriade, Loren Trigo, Moira Yip. And Betsy Klipple, for sharing an office and a great friendship.

My apology for those whose names may be unintentionally left out.

This thesis could not be written in the present form without the guidance of my committee members, Professors Francois Dell, Morris Halle and Ken Hale. In ways too numerous to enumerate, they contributed greatly to the thesis development. Francois readily shared with me his knowledge of Southeast Asian languages and Chinese dialects, and his theoretical insights. His detailed reading of earlier drafts made me think twice about my proficiency in Pinyin. Ken drew my attention to more global issues, and to the formal similarities among different branches of linguistics. Morris's "harassment" improved the thesis enormously. In fact, the thesis took shape as much in the talks I had with him as in the time between the talks. Morris kept me on linguistic issues when I felt like a happy eel in the deep mud of linguistic data. I owe him a huge intellectual debt. Professors Donca Steriade and Michael Kenstowicz deserve a [+strident] note of thank-you. Undoubtedly they will find their ideas in the pages that follow.

And my gratitude to two linguists in Fudan University, Shanghai, Professors Cheng Yu-min and Xu Lie-jiong.

Finally I want to thank two institutions, MIT and IIE -- MIT for giving me a scholarship and an education; and IIE, the administrator of the Fulbright graduate program, for being my sponsor.

Table of Contents

Chapter One: An Overview	7
1.1 The Geometry of Tone	7
1.2 Tone as Autosegmental Tier	11
Chapter Two: Theories of Tone: A Survey	16
2.1 The Yin-Yang Registers	16
2.2 Chao (1930)	19
2.3 Wang (1967)	21
2.4 Woc (1969)	25
2.5 Yip (1980)	31
2.6 Clements (1983)	37
2.7 Hyman (1986)	42
2.8 Shih (1986)	44
2.9 Yip (1989)	47
2.10 Hyman (1989)	49
2.11 Halle and Stevens (1971)	53
Chapter Three: The Representation of Tone	57
3.1 The Geometry of Tone	57
3.2 The Motivation of Underlying Contour	67
3.3 Assimilation in Tone Sandhi	69
3.3.1 Tone Assimilation	69
3.3.1.1 Danyang	69
3.3.1.2 Changzhi	83
3.3.2 Register Assimilation	88
3.3.3 Contour Assimilation	95
3.3.3.1 Zhenjiang	96
3.3.3.2 Wenzhou	105
3.3.4 Feature Assimilation	111
3.4 Contours and Other Matters	117
3.4.1 Distributional Properties of Tones	117
3.4.1.1 The Distribution of Even Tones	117
3.4.1.2 The Distribution of Falling/Rising Tones	122
3.4.2 Convex and Concave	125
3.4.2.1 Changzhi	126
3.4.2.2 Xining	134
3.4.3 Contour Simplification	141
3.5 Tone and The Geometry of Laryngeal Features ..	148
3.6 Contour System versus Level System -- a Parametric View	160
3.7 Some Problematic Consequences of the Theory ..	165
3.7.1 Syllabic Nasals and Obstruents	166
3.7.2 Unusual Tonal Inventories	171

Chapter Four: Autosegmental Nature of Tone	175
4.1 Tonal Morphemes	178
4.1.1 Danyang Word Melodies	178
4.1.2 Wenzhou Definitive Morpheme	180
4.1.3 Cantonese Changed Tones	182
4.1.4 Prefixes in Jiading Miao	194
4.2 Tone under Segmental Deletion	199
4.2.1 Cantonese	199
4.2.2 Fangjie Languages	204
4.3 The Bridge Effect	207
Chapter Five: Tone in Phonological Representation	218
5.1 The Dual Nature of Tone	218
5.2 Structure-Dependency of Tone Stability	232
5.3 Segmentalization of Tone	245
5.4 Phonological Processes of Tone Sandhi	271
5.4.1 Assimilation	272
5.4.2 Dissimilation	280
5.4.3 Other Sandhi Processes	282
Chapter Six: The Mid Tone	284
6.1 The Numerals	292
6.2 The Classifiers	298
6.3 R-Lowering Re-visited	305
Appendix	311
References	327

for a speaker of a tone language

Le mieux est l'ennemi du bien

Chapter One
An Overview

This thesis is a study on tone. It addresses two issues which are at the center of research in nonlinear phonology: the internal structure of phonological elements (such as segments and tones), and the overall structure of phonological representation. The thesis deals with the geometry of tone and how it fits in the geometry of laryngeal features, and the relation between tone and other autosegments, particularly syllable structure. In this chapter, I sketch in general terms the theoretical results of this study.

1.1 The Geometry of Tone

First, the geometry of tone. I argue that tone consists of register and contour, formally represented in (1):

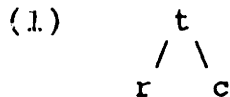

The two nodes play different conceptual roles. The r node specifies the pitch level of the tone; whereas the c node specifies how the tone behaves in the temporal duration of the tone bearing unit. The register is therefore tone's static aspect, and the contour its dynamic aspect. These two

components of tone are encoded in the structure in (1) as sister nodes dominated by the tonal root node *t*. In Chapter Three I show that the structure in (1) accounts for a wide range of phonological phenomena of tone sandhi found in various dialects of Chinese and other Southeast Asian languages.

The register node is specified by the laryngeal feature [stiff (vocal cords)]. Formally the *r* node is a nonterminal node which dominates a single feature:



The contour node is specified by the laryngeal feature [slack]. Following Yip (1980, 1989), the feature [slack] may occur in sequence. The *c* node has two formal configurations:



(3a) is the configuration for an even (or level) tone; and (3b) is the configuration for a contour tone. The values of the feature [slack] in any given sequence are different. It is assumed that the configurations in (4) are conceptually equivalent to (3a):

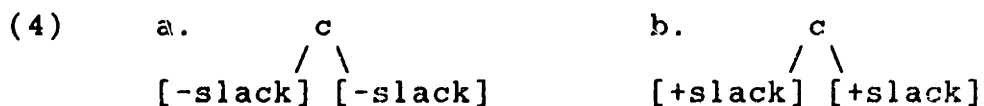

In articulatory terms, the features provide articulatory instructions to the relevant articulators (Halle (1983)). Since the branching of the c node is temporal, the sequences of [slack] in (4) provide the same articulatory instructions to the same laryngeal articulator (more on this later) over time. Similarly, in the configuration (3a), the single feature [slack] provides the same articulatory instructions over time. The articulatory effect produced by the configurations in (4) and that produced by (4a) are identical. An articulatorily meaningful branching structure involving a single feature must have different specifications.¹

The formal apparatus postulated so far gives the following structures:

1. It is possible to invoke the Obligatory Contour Principle to rule out the structures in (4). Since nowhere in the thesis is the OCP invoked, I do not attempt to use it for this purpose. For recent discussions on the theoretical status of the OCP, see McCarthy (1989a) and the references cited there.

(5)	Register:	High	r [+stiff]
		Low	r [-stiff]
	Contour:	Even	c [+slack]
			c [-slack]
		Rise:	c / \ [+slack] [-slack]
		Fall:	c / \ [-slack] [+slack]

Since tone is phonetically executed by the vocal cords, it is claimed that the geometry of tone is a substructure of the geometry of laryngeal features. The laryngeal geometry I propose has the following structure (LAR=laryngeal; VC=vocal cords; GL=glottal; CT=cricothyroid; VOC=vocalis):

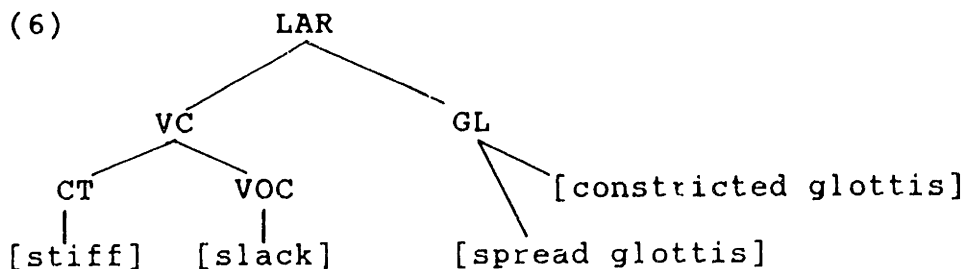

The geometry of tone is the geometry of the VOCAL CORDS, which I take to be the articulator that executes tone. It is

speculated that the cricothyroid executes the register feature [stiff] and the vocalis executes the contour feature [slack] (see §3.5).

1.2 Tone as Autosegmental Tier

The claim that the geometry of tone is part of the geometry of laryngeal features commits one to the view that tone is phonetically realized on segments. I assume that tone is realized on segments which serve as syllabic nucleus. The canonical tone-bearing segments are vowels.

At the level of representation prior to phonetic execution, tones must be represented as autosegments independent from the segments on which they are realized. The tone-segment segregation accounts for the phenomenon known as tone stability -- tone often survives segmental deletion. In nonlinear phonology in which phonological representation is rich in structure, the notion of tone-segment segregation can be formally captured in two ways: tone as an autosegmental plane, or tone as an autosegmental tier on the syllabic plane. Planes and tiers are distinct formal entities, as shown by the bi-planar representation in (7):

(7)

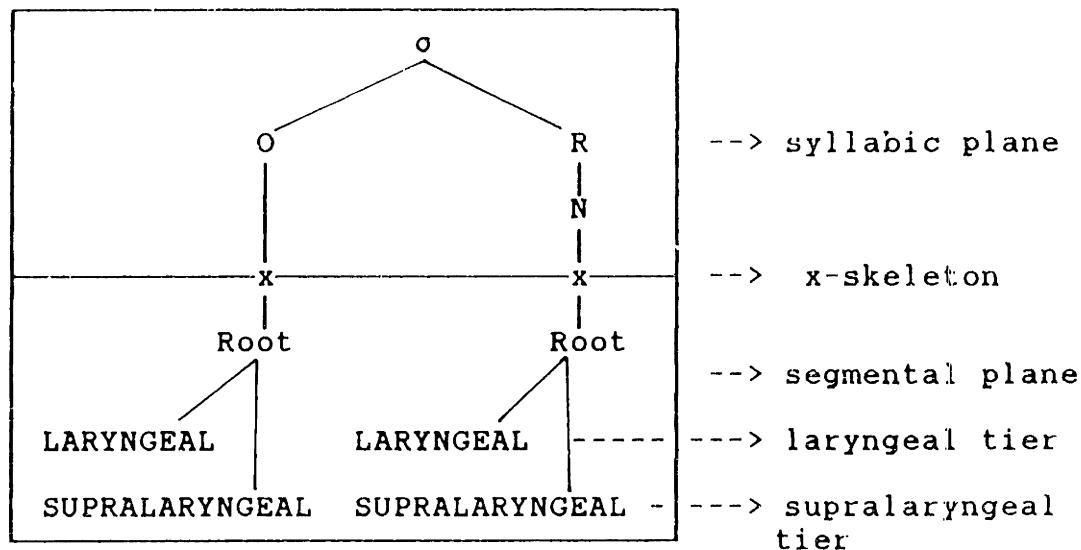

The terms "plane" and "tier" have many different uses in the literature. My use of the terms essentially follows Archangeli (1985). Archangeli's definitions are as follows:

Tier refers to plane-internal sequences of matrices parallel to the core skeleton. *Plane* refers to the entire melody (or structure) anchored in the core skeleton. (p. 336)

"Core skeleton" is the x-skeleton. Since segments are no longer conceived as feature matrices, but rather as root nodes having internal geometrical structure, the term "tier" is modified to refer to sequences of nodes of the same type. In (7), the laryngeal nodes of the onset and nucleus form the laryngeal tier. The same is true of the supralaryngeal nodes. The LARYNGEAL and SUPRALARYNGEAL nodes do not form a tier, as they are of different types. Tiers are internal to

a plane, and the root melodies which define a plane are anchored on the x-skeleton. They can only be anchored on the x-skeleton.²

Tone can be represented as an autosegmental tier on the syllabic plane, as in (8a); or as an autosegmental plane anchored on the x-skeleton, as in (8b):³

(8) a. Tone (t) as Autosegmental Tier

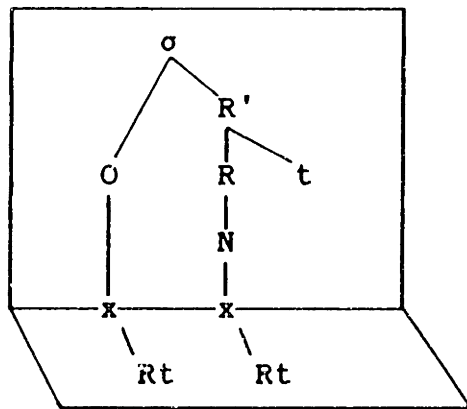

2. Pulleyblank (1986) makes the following stipulation:

- (i) Autosegmental tiers can only link to slots in the skeletal tier

Pulleyblank's use of the term "tier" is equivalent to "plane." See also discussion in Chapter Five.

3. The representation of tone is independent of the issues of V/C segregation, since tone stability can be accounted for only when tone is assumed to be autosegmental, regardless whether vowels and consonants are on separate planes.

b. Tone as Autosegmental Plane

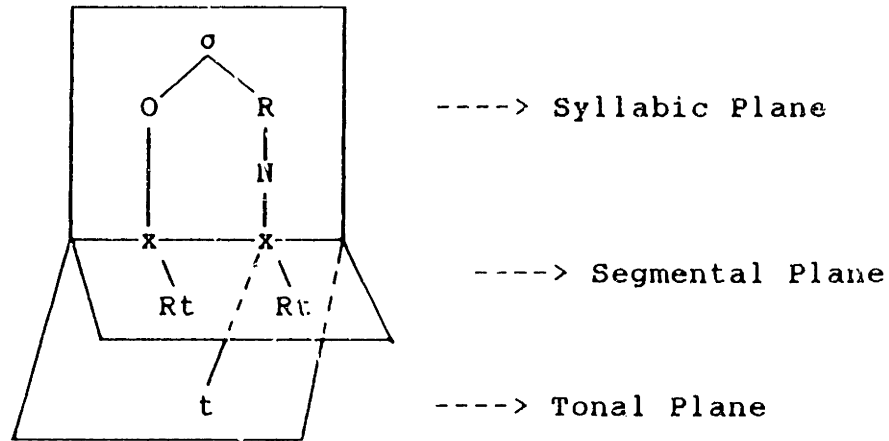

In both representations tone mapping may be governed by the same set of conventions called Association Conventions and the same Well-Formedness Condition. The Association Conventions and the Well-formedness Condition in (9) are due to Pulleyblank (1986:11):

(9) Association Conventions

Map a sequence of tones onto a sequence of
 tone-bearing units, (a) from left to right
 (b) in a one-to-one
 relation

Well-Formedness Condition

Association lines do not cross.

I have nothing to say about the empirical validity of the Association Conventions, particularly the directionality of mapping (a). The Well-formedness Condition may be derivable from extra-linguistic considerations, see Hammond (1988) and Sagey (1988).

An Overview

In the structure (8a), tone is adjoined to the tone-bearing unit, which in this thesis is argued to be the rime (R). The syllabic elements are temporally ordered by virtue of their x-skeleton positions. O necessarily precedes R in time. Tone, when adjoined to the R node, does not precede R in time. It is "simultaneous" with R, with which it is associated. In the structure (8b), tone is associated with the x-slot of the nucleus segment. Tone is an element on the tone plane, which is anchored on the x-skeleton.

I argue in Chapter Five that tone stability is structure-dependent, and can be explained only by assuming the structure in (8a). To derive the structure in (8a), I assume that tone mapping is an adjunction process: it adjoins tone t to R, creating a new segment of the rime node, R':



Tones form an autosegmental tier on the syllabic plane; they do not form an autosegmental plane.

Chapter Two

Theories of Tone: A Survey

2.1 The Yin-Yang Registers

In Chinese philological and linguistic literature tones are classified into the yin and yang registers. Historically the yin tones occur on syllables with voiceless initial obstruents, and the yang tones occur on syllables with voiced initial obstruents. The voiced obstruents of Middle Chinese (ca. 600AD) are lost in many modern dialects, mostly of the Mandarin variety. But dialects which are spoken mostly in the southern coastal areas of China still maintain voicing as a distinctive feature among obstruents. In many dialects with voiced obstruents the yin tones are higher in pitch than their yang counterparts. The tones are further classified into four tonal categories, ping "Even", shang "Rising", qu "Departing" and ru "Entering". Each of the four tonal categories can be realized in both yin and yang registers, giving a total of eight tones:¹

1. Unless otherwise stated, tones are listed in accordance with their historical origin, as follows:

- (i) (a,A) represent the Ping (Even) tones
(b,B) represent the Shang (Rising) tones
(c,C) represent the Qu (Going) tones
(d,D) represent the Ru (Entering) tones
- (ii) Lower-case letters represent the yin tones;
upper-case letters, the yang tones.

Theories of Tone: A Survey

(1) Traditional Classification of Tones

	yin-register		yang-register
a.	ping (Even)	A.	ping (Even)
b.	shang (Rising)	B.	shang (Rising)
c.	qu (Departing)	C.	qu (Departing)
d.	ru (Entering)	D.	ru (Entering)

The ru tones are the so-called checked tones, because they are realized on syllables ending in /p t k ?/, depending on the dialect. As we will see later, the ru tones are derivable from either ping, shang or qu. The classification in (1) does not give the phonetic pitch of the tones, which is the reason why we have no clear idea what the tones in Middle Chinese were in terms of their phonetic realization. The names may reflect the phonetic properties of the tones at the time when they were coined, but, judging by modern dialects, the names of the tones are hardly an indication of their pitch height or shape. For instance, the yin ping (1a) is realized as 55 in Beijing Mandarin, but in Tianjin, a port city a hundred miles or so towards the southeast, the tone is realized as 21.

The system in (1) is non-phonetic in character; since it specifies eight tones without giving their phonetic pitch

values.² The insight of the system as an abstract representation of tone is that it explicitly recognizes no more than two pitch registers, the yin register and the yang register, which are correlated with the voicing qualities of the syllable-initial consonants. The system serves a diachronic purpose by helping identify the historical origin of tones in modern dialects. Although it fails as a phonetic tool for synchronic analysis, the yin/yang registers prove to be a viable theoretical device to capture the phonological regularities of tone sandhi. Attempts have been made, notably Yip (1980) and Pulleyblank (1986), to formalize pitch registers in terms of tonal features, as will be apparent in the discussion to follow.

2. According to Mei (1970:104), the tones in Middle Chinese can be characterized as follows:

Level:	long, level, and low, with a higher and a lower allotone.
Rising:	short, level, and high, its lower allotone having merged with the departing tone.
Departing:	slightly drawn out and hence longish.
Entering:	short.

2.2 Chao (1930)

The numbers by which the two yin ping tones were represented in the preceding section, the high level 55 and the low falling 21, are the relative pitch values of the tones, with 1 being the lowest in pitch and 5 the highest. This system is widely used in Chinese linguistics literature. The number notation was first introduced in Chao (1930/1980) as a systematic method of representing the phonetic pitch of tones. Chao's system divides a pitch scale into five distinct levels, ranging from 1 (the lowest) to 5 (the highest). It provides a convenient method of phonetically transcribing auditory impressions of tone height. A high falling tone may be transcribed as 53, a high concave tone as 535. Short tones are represented with a single digit if they are level, and with underlined digits if contour. So a high short tone may be 5, and a high falling short tone, 53. It must be pointed out that the numbers represent relative pitch values. For phonological purposes, a 42 in one tone system may be a high falling tone, but in another it may be low falling.

The number notation is inadequate in two ways. First, the system generates too many tones. By Wang's (1967:98) calculation, there will be a total of 125 theoretically possible tones if up to three positions are allowed for

tonal specification.³ No tone language contains so many distinctive tones in its tonal inventory. Second, the numbers fail to give a straightforward account of phonologically relevant tonal alternations, among them the correlation between syllable-initial consonant voicing and tone pitch (see the tone inventory of Songjiang below). By using five digits, Chao's notation provides up to five tones with distinct pitch levels. Ever since Chao (1930), the number five enjoys a special status in the investigation of tonal systems, at least in the field of Chinese dialectology. Languages with five distinct level tones phonetically and phonologically remain to be documented.⁴

Using the number notation, the tonal inventory of Songjiang, spoken in the suburb of Shanghai, is as follows (Jiangsu...(1960)) ("Even," "Rising," "Departing" and "Entering" are the traditional names for tones):

3. Chao (1930/80) stipulates that points 2 and 4 can not be used in combination with 1, 3, or 5. This reduces the number of tones considerably. But this stipulation is often ignored in later work on tones.

4. See the discussion in §3.7.2, Chapter Three.

(2) Tonal Inventory of Songjiang

yin-register

- | | | |
|----|-----------------|---------------------------|
| a. | 53 (Even): | ti "low"; t'i "ladder" |
| b. | 44 (Rising): | ti "bottom"; t'i "body" |
| c. | 35 (Departing): | ti "emperor"; t'i "tear" |
| d. | 5 (Entering): | pa? "hundred"; p'a? "tap" |

yang-register

- | | | |
|----|-----------------|--------------|
| A. | 31 (Even): | di "lift" |
| B. | 22 (Rising): | di "brother" |
| C. | 13 (Departing): | di "field" |
| D. | 3 (Entering): | ba? "white" |

2.3 Wang (1967)

In Chao's numerical representation the tones are conceived to be single, atomic entities. 53 does not imply that the high falling tone is composed of the high point 5 followed by the mid point 3. 53 is a unitary high falling tone, and its yang-register counterpart, 31, a unitary low falling tone. With the introduction of distinctive features (oppositions) into phonological theories (Trubetzkoy (1958)), segments were no longer conceived as entities which were not further decomposable. In the framework of generative phonology, as spelled out particularly in the influential work of Chomsky and Halle (1968), segments such as vowels and consonants are conceived as bundles of features. Wang (1967) is a systematic attempt in this direction. He decomposes tones into seven features. (3) is the feature specification of thirteen tones (Wang

(1967:97)):

(3) Table of Tones and Their Features

	1	2	3	4	5	6	7	8	9	10	11	12	13
	⌒	⌒	⌒	⌒	⌒	⌒	⌒	⌒	⌒	⌒	⌒	⌒	⌒
contour	-	-	-	-	-	+	+	+	+	+	+	+	+
high	+	-	+	-	-	+	-	+	-	+	-	+	-
central	-	-	+	+	+	-	-	-	-	-	-	-	-
mid	-	-	-	-	+	-	-	-	-	-	-	-	-
rising	-	-	-	-	-	+	+	-	-	+	+	+	+
falling	-	-	-	-	-	-	-	+	+	+	+	+	+
convex	-	-	-	-	-	-	-	-	-	-	-	+	+

Among the seven features, [high], [central] and [mid] are responsible for pitch levels, and four, [contour], [rising], [falling] and [convex] give the pitch contours of the thirteen tones. Since seven features can specify 128 distinct tones, excessive ones are trimmed by means of redundancy conventions.

Like Chao's number notation, Wang's feature system generates five distinct pitch levels, but two tones are theoretically possible for each of the [+contour] tones. As the tone table in (3) indicates, the pitch level opposition among the [+contour] tones is that between high and non-high. The other two features, [central] and [mid] play no role in defining [+contour] tones. This implies that a tone language can have only two falling tones which are phonologically distinct, and the difference in their pitch levels is high versus non-high. The same is true of the other contour tones. The feature [high] has special status

Theories of Tone: A Survey

in Wang's system in that it draws the basic distinction in a tone language, at least among the [+contour] tones. This is consistent with the traditional binary grouping of tones into the yin (high) and yang (low) registers, although the yin/yang division extends to all tones in the traditional analysis. The inclusion of [central] and [mid] is motivated solely by the descriptive need to represent five distinct level tones. The thirteen tones that Wang's system provides are distributed as follows:

(4) Number of Tones in Wang's System

- a. level tones: 5
- b. rising tones: 2
- c. falling tones: 2
- d. convex tones: 2
- e. concave tones: 2

Using Wang's features, the Songjiang non-checked tones can be specified minimally as follows:

(5) Tonal Inventory of Songjiang

yin-register		yang-register	
a. 53	[+contour +high +falling]	A. 31	[+contour -high +falling]
b. 44	[-contour +high +central]	B. 22	[-contour -high +central -mid]
c. 35	[+contour +high +rising]	C. 13	[+contour -high +rising]

The short tones (2d,D) are derived from (5a,A); the shortening can be attributed to the obstruents in syllable coda position.⁵

Two properties may be noted concerning Wang's features. First, like Chao (1930/1980), up to five distinct pitch levels are made available for any given tone language; however, the theory has no formal device which correlates the pitch levels with the voicing qualities of the initial consonants of the syllables on which the tones are realized. This differs from the traditional analysis which groups tones into the yin and yang registers, although, as we have mentioned earlier, Wang's treatment of contour tones bears resemblance to binary opposition. The yin/yang registers in their historical context have a strict correlation with the voicing qualities of the initial consonants. Second, in order to describe the contour tones which exist abundantly in Chinese and other languages of South-east Asia, Wang's system makes use of the temporally dynamic features such as [falling] as theoretical primitives. This is made necessary in part by the unstructured nature of the three level features, and the conception of tones as matrices (or vectors) of features lacking internal organization. If the

5. It is possible to view the short tones 5/3 as derived from 44/22. In the absence of phonological data, the decision to treat 5/3 as derived from 53/31 is, admittedly, arbitrary. But nothing hinges on the issue.

features were allowed to occur in temporally meaningful sequence at some level of representation, contour features as primitives could be avoided. Theoretically, however, this is still several years in the future, after the advent of autosegmental phonology (see Williams (1971/1976), Goldsmith (1976a,b), Yip (1980)). Wang's system is consonant with the general theoretical temperament of the time. After all, early SPE-style generative phonology treats a phoneme as a bundle of features, an unstructured bundle at that.

2.4 Woo (1969)

The postulation of dynamic features generates a great deal of controversy. The success of describing tonal phenomena of African languages in terms of pitch levels leads one to expect that languages such as Chinese may be analyzable in the same way, and contour tones (what Woo calls dynamic tones) in those languages may simply be the result of concatenating two level tones on a single, sufficiently long syllable. For instance, a high level tone followed by a low level tone on the same syllable creates the dynamic contour of falling. This is precisely the approach Woo takes in her analysis of contour tones. But in a linear representation which Woo's theory assumes, tones must be realized on segments, and there can only be one tone

for one segment. A contour tone on a single syllable therefore requires that the syllable be long. In Woo's theory contour tones do not occur in short syllables. Short syllables may have level tones only.

Three features, [high tone], [low tone] and [modify], are proposed to specify five distinct pitch levels. Contour tones are concatenations of the five level tones. (6) are the feature specification of the level tones (Woo (1969:146)); the number notation is added:

(6)	55	44	33	22	11
high tone	+	+	-	-	-
low tone	-	-	-	+	+
modify	-	+	-	+	-

The features in (6) are functionally similar to [high], [central] and [mid] of Wang (1967). Redundancy rules are needed to trim the number of level tones down to five. For comments on Wang's and Woo's features, and a survey of other feature systems which are not discussed here, see Fromkin (1972,1974).

What sets Woo's theory apart from Wang's (1967) is the treatment of the dynamic aspect of tone. In Wang's system, contour tones are specified in terms of the dynamic features of [contour], [fall], and [rise]. The length of the syllable is irrelevant. Woo, on the other hand, represents contour tones as concatenations of level tones. The syllable length

becomes important in justifying the existence of contour tones. In syllables of the form CV, the vowel is treated in her theory as geminate clusters. CV is in effect CVV. This allows a sequence of two level tones to be realized on a single syllable. The claim, as we have noted earlier, is that contour tones can occur in long syllables (either geminate vowels CVV or CVS, where S represents sonorants other than vowels), but not on short syllables (Woo (1969:62)).

This claim, however, is not empirically supported. In Mandàrin Chinese Woo's theory does not appear to be problematic, since the coda of a Mandarin syllable can only be a nasal. When we consider dialects with syllables ending in obstruents such as /p t k/, we discover a whole range of dynamic tones realized on short syllables. Pingyao is a case in point. This dialect has five tones, as in (7) (Pingyao data are taken from J.Y. Hou (1980)):

- (7)
- | | | |
|----|-------------|--------------------------|
| a. | 13: | pu "hatch" |
| b. | 35: | pu "cloth" |
| c. | 53: | pu "mend" |
| d. | <u>23</u> : | pʌ? "push aside" |
| e. | <u>54</u> : | pʌ? a musical instrument |

The short tones are underlined. In citation form, we see two falling tones 53 and 54, three rising tones 13, 35, and 23. The short tones, which are dynamic (falling in 54 and rising in 23) are realized on syllables ending in the glottal stop.

Consider now the following sandhi data:

(8) a. 13 53 > 31 53

tɕi t'uə	"chicken leg"
sa t'u	"sandy earth"
ku kuæ	"ankle"
tɕ'ig iəu	"relative"

b. 23 53 > 32 53

sʌʔ k'əu	"mouthpiece for draft animal"
k'uʌʔ tɕ'i	"start crying"
xuʌʔ t'io	"mix"
tsʌʔ pɔ	"tie"

c. 53 53 > 35 423

ta tig	"take a nap"
mæ ɕi	"curry favor"
tɕ'i ts'o	"in heat"
ər nzuaŋ	"soft ear"

d. 53 54 > 35 423

ts'uag niʌʔ	"establish"
səŋ liʌʔ	"save strength"
ts'æ yʌʔ	"gather herbs"

e. 54 54 > 45 423

ʂʌʔ miʌʔ	"gather wheat"
xuʌʔ yʌʔ	"take medication"
tuʌʔ ʂʌʔ	"fight for food"
xuʌʔ iʌʔ	"military service"

The sandhi patterns in (8a,b) are what Hou calls Type A patterns, and those in (8c,d,e) are Type B patterns. Phrases of the verb-object or subject-predicate construction exhibit Type A sandhi; and phrases of other syntactic constructions exhibit Type B sandhi. The sandhi patterns in (8) show that 23 and 13, 54 and 53, are derived from the same underlying

tones, since they have the same sandhi behavior. What is of interest to us is the distribution of the short tones.

Notice that more dynamic short tones are generated through sandhi: 32 (8b) and 423 (8d,e). These two tones, and 31 and 423, do not occur in citation form. I arrange the two series of tones in (9):⁶

(9) in long syllables:	13	35	31	53	423
in short syllables:	<u>23</u>	<u>45</u>	<u>32</u>	<u>54</u>	<u>423</u>

The contour tends to level off when realized on short syllables except the concave 423, of which the concavity remains the same on both types of syllable. As for the rising and falling tones, the contour does not level off completely. The two series of tones in (9) present a problem for Woo's theory, which predicts that dynamic tones cannot occur on short syllables. The contour of a tone is not directly related to the length of the tone bearing unit.

Another problem for Woo's treatment of dynamic tones has to do with the interaction between the voicing qualities of consonants and the pitch height of tones. Consider the two falling tones of Songjiang 53 versus 31 (cf. (2)). In Woo's theory the two tones can be represented as in (10):

6. For a detailed analysis of the Pingyao tone sandhi, see §3.3.2, Chapter Three.

- (10) a. 53 CVV b. 31 CVV
 || ||
 HM ML

In Songjiang, 53 and 31 are in complementary distribution: 53 occurs with voiceless consonants in syllable-initial position, whereas 31 occurs with voiced consonants. Suppose that 53 is the underlying tone. Voicing depresses the tone's pitch height (namely the register) without changing the dynamic aspect of it. Both tones are falling in contour. This fact cannot be captured in Woo's model, since the influence of consonant voicing will not only be upon H, but also upon the nonadjacent M, as shown in (11):

- (11) C VV (surface: C VV)
 | || | ||
 [+voice] HM [+voice] ML

To derive 31 within Woo's model, the syllable-initial consonant voicing must condition the H>M sandhi as well as the M>L sandhi simultaneously. In Halle and Stevens (1971), voiced consonants and low pitch are specified as [-stiff]. The phenomenon in (11) is a case of assimilation. The M>L alternation violates the locality requirement on assimilation. Woo's theory is therefore inadequate in explaining the distribution of contour tones, as well as the interaction between consonant voicing and tonal pitch.

2.5 Yip (1980)

The two systems of tonal representation which we have reviewed here, Wang (1967) and Woo (1969), are representative of the work in this area, particularly with respect to the treatment of dynamic tones. Since Chao (1930), linguists appear to agree that any feature system must be capable of providing five distinct levels to be descriptively adequate. This necessitates the postulation of at least three features, with excessive tonal specifications to be ruled out by redundancy rules or conventions. True to the theoretical spirit of early generative phonology, the three level features, [high], [central] and [mid] in Wang's theory and [high tone], [low tone] and [modify] in Woo's theory, are arranged into matrices, and there is no internal structure among the features. In this regard, Yip (1980) represents a significant theoretical departure in the number of features postulated (two) and their relationship (one dependent on the other).

Yip's work must be understood against the theoretical background of autosegmental phonology with its vastly enriched phonological representation (see Williams (1976), Goldsmith (1976a,b), McCarthy (1979), Halle and Vergnaud (1980,1982), among others). The meager, single-tiered representation of early generative phonology gives way to

multi-tiered representation with intricate internal structure. In Goldsmith's work, tones are considered as independent entities on a tier separate from that of the tone bearing units or TBUs, and the two tiers are linked by means of the universal association conventions (see discussions in Chapters One and Five).

The two features that Yip (1980) proposes, Register and Tone, are to be interpreted in autosegmental terms. They interact to give four pitch levels (Yip (1980:196)):⁷

(12)	Register	Tone
	+ upper	+high (H)
	- upper	-high (L)
	+ upper	+high (H)
	- upper	-high (L)

(The Tone feature [high] was later renamed by Pulleyblank (1986) as [raised], and it is this feature we will use in

7. Gruber, as reported in Fromkin (1972), has a two feature system which can specify up to four distinct level tones. He calls the features [high] and [high 2], and the four level tones are specified as follows:

[+high
+high 2] [+high
-high 2] [-high
+high 2] [-high
-high 2]

According to Fromkin (1972:47), implicit in Gruber's proposal is "the claim that the basic distinction in any tone language is between high tones and non-high tones, with all other tonal contrasts being made within these two disjunctive sets." Gruber's system anticipated Yip's.

place of [high].) Yip's theory is innovative in two ways. First, the two features play different theoretical roles. The Register feature first splits the entire pitch range into two halves, each of which is in turn subdivided by the feature [raised]. Although both [upper] and [raised] are binary features which bisect a certain pitch range, the operation of [raised] depends on [upper]. In Yip's (1980:196) terms, Register is "dominant." Secondly, the two features are distinct autosegments associated with a single tone bearing unit. The relationship between the TBU and the Register is one-to-one; and that between the TBU and the Tone is one-to-many. In other words, the Tone feature may occur in sequences of two (or possibly more) which are associated with a single TBU, but not the Register feature. The sequence of the Tone feature gives the contour of the tone. The relationship among Register, Tone and TBU is illustrated in the representations of a high falling tone and a high rising tone in (13):

(13) a. High Falling Tone

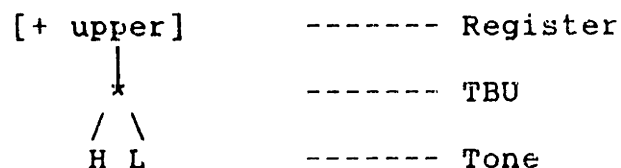

b. High Rising Tone

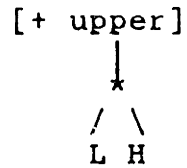

The two pitch registers specified by the feature [upper] can be seen as functionally equivalent to the yin and yang registers we have discussed before. Since the sequence of the Tone feature gives the tone its contour, Yip's feature system makes the claim that the contour of a tone is relativized to its pitch register. The register itself, in Yip's (1980:196) words, "remains constant over the morpheme." Languages which contain 51 or 15 as contrastive tones in their tonal inventories are rare. Typically, in dialects which have two contrastive falling or rising tones, we will find 53 (or 42) in opposition with 31. Given sufficient degree of idealization, the high variant is in the yin register, and the low variant is in the yang register.⁸

8. The phonetic difference between 53 and 42 is phonologically irrelevant. Often it is an idiosyncrasy of the field linguist. Wang (1967:98) lists two reports of the Suzhou dialect (spoken in Suzhou, the Jiangsu province) prepared at roughly the same time, as follows:

- | | | | | | | | | |
|-----|----|----|----|----|-----|-----|---|----|
| (i) | a. | 44 | 13 | 52 | 412 | 31 | 5 | 2 |
| | b. | 44 | 24 | 41 | 513 | 331 | 4 | 23 |

The differences between the two reports on the phonetic pitch of the tones are "probably more spurious than real."

Yip's system is highly restrictive. The representation of contours as sequences of specifications of the feature [raised] puts an upper limit on how contours may be created. In the unmarked case, contours are restricted to the register specified by [upper]. In all, Yip's theory gives twelve tones, as in (14):

- (14) a. Level:
- | | |
|-------------|-------------|
| [+upper, H] | [-upper, H] |
| [+upper, L] | [-upper, L] |
- b. Rising:
- | | |
|--------------|--------------|
| [+upper, LH] | [-upper, LH] |
|--------------|--------------|
- c. Falling:
- | | |
|--------------|--------------|
| [+upper, HL] | [-upper, HL] |
|--------------|--------------|
- d. Concave:
- | | |
|---------------|---------------|
| [+upper, HLH] | [-upper, HLH] |
|---------------|---------------|
- e. Convex:
- | | |
|---------------|---------------|
| [+upper, LHL] | [-upper, LHL] |
|---------------|---------------|

Yip's position on the concave and convex tones is not clearly spelled out. In her analysis of Fuzhou, the tone 242 is represented as [+upper, LHL] (Yip (1980:341)), so at least she allows sequences of three Tone features. It may be observed that no language contains tones with more complex

Under certain degree of idealization, the difference between 53 and 42 is no more real than that between 52 and 41. What is interesting is that 51/31 remains observationally rare.

pitch contours than convexity or concavity. This is explicit in Wang's (1967) feature system, which is incapable of specifying featurally a fall-rise-fall-rise contour. Such contours are theoretically possible in Woo's (1969) theory. Since contour tones are represented by sequences of level tones, the sequence HLHL, all associated with a sufficiently long syllable, is expected to occur. The same is true of Yip's (1980) theory, in which the Tone feature sequence of HLHL is possible. To avoid overgeneration, Yip's system needs the following stipulation:

- (15) The maximum number of Tone feature occurrences in sequence is 3

This stipulation allows concave tones such as [+upper, LHL], but rules out non-occurring tones such as [+upper, LHLH] or [+upper, HLHL].

By now the differences and similarities between Yip's theory and that of Woo (1969) should be clear. In terms of the tone inventory generated, a major difference between Yip's system and that of Woo's lies in the number of possible level tones. Yip's system can generate four distinct level tones, whereas Woo's system generates five. The representation of contour is similar in that neither theory makes use of primitive contour features, and both theories represent contours as clusters. In Woo's model clusters consist of feature matrices; in Yip's model they

consist of sequences of specifications of the feature [raised] on the Tone tier. The two representations of the high falling tone in (16) illustrate:

(16) a. Woo's Representation



b. Yip's Representation

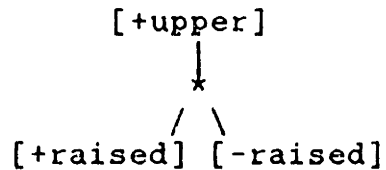

where * is the tone bearing unit.

2.6 Clements (1983)

In the feature systems surveyed so far, tones are specified by binary features. Clements' theory provides for multiple tone heights without the express use of binary features. Recall that in Yip's theory the two features [upper] and [raised] bisect the pitch scale. The feature [upper] is dominant in that it divides the pitch into two registers, which are then further divided by the feature [raised] into two subregisters. The feature [raised] is dependent on the feature [upper]. The dominance relationship between the two features is made explicit in Clements's (1983) theory of tone hierarchy, and encoded in the notion

of rows. Tones are defined as "tonal matrices which consist of ordered rows of the elements h, l, or 0." (Clements (1983:150)) h is relatively high pitch, and l relatively low pitch. The number of rows in the tonal matrices is limited only by human perception. The exact number of rows is dependent upon the tonal inventories of individual languages. Two-level, three-level and four-level tone systems are specified as follows:

(17) a. two-level system

	H	L
row 1:	h	l

b. three-level system

	H	M	L
row 1:	h	l	l
row 2:		h	l

c. four-level system

	H	HM	M	L
row 1:	h	h	l	l
row 2:	h	l	h	l

In (17b), the low register is further divided into two row 2 pitches, which Clements considers as the unmarked case. This expresses the fact that the primary opposition among tones is that between high tones (H) and nonhigh tones (M and L). Note that in a four-level system (17c) Clements's

system is identical to Yip's: row 1 features correspond to Yip's [upper]; and row 2 features correspond to Yip's [raised]. Thus, H in (17c) is equivalent to [+upper, +raised], HM to [+upper, -raised], M to [-upper, +raised], and L to [-upper, -raised], which is lowest on the pitch scale. Despite the ready correspondence, there are major conceptual differences between Yip's features and Clements's rows. I will have more to say on the notion of row shortly.

In a recent paper (Clements (1989)), the tonal matrices are represented in a tree notation in which occurrences of h/l on each row link to a class node called tonal node. The four-level system in (17c) has the tree structure as shown in (18):

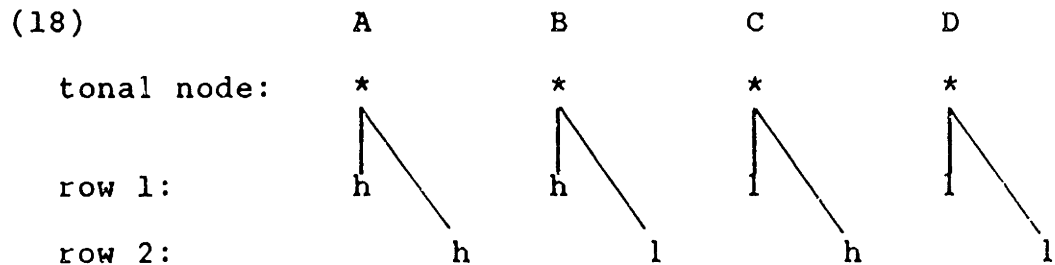

The tree notation captures an often observed fact of tone sandhi, that is, the features which define tones spread as a unit. If row 1 occurrences of h/l and row 2 occurrences of h/l are not linked to a single tonal node, tone spreading would have to be expressed as the simultaneous spreading of row 1 and row 2 occurrences of h/l, which is the consequence of Yip's (1980) theory. In Yip (1980) [upper] and [raised]

are two independent autosegments associated with a single tone bearing unit. This runs into difficulty in accounting for tone spreading facts (see §3.3.1). The difficulty does not arise in a representation such as (18), where the two rows (or [upper] and [raised] features) are sister nodes under the tonal nodes.

The tree notation is not merely a notational variant of the matrix notation first proposed in Clements (1983). Compare the representations of a four-level system in (17c) and (18). In (17c) row 1 dominates row 2 within the tonal matrices. The matrices are linked to the TBUs, not the individual rows that make up the matrices. In (18) the two rows stand in a sisterhood relationship under the tonal node, which is linked to TBUs. One important feature of Clements's theory needs to be emphasized. Although the elements *h* and *l* may be characterizable in terms of a single binary feature, the organization of the rows is hierarchical. The occurrences of *h/l* on row *n* depends on occurrences of *h/l* on row *n-1*. In other words, (19a) is interpretable, but (19b) is not, be it underlying or generated by some phonological rule:

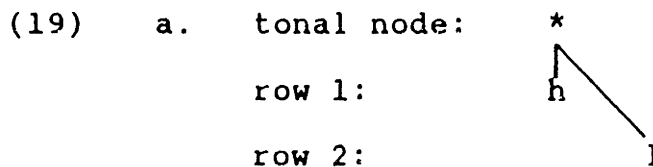

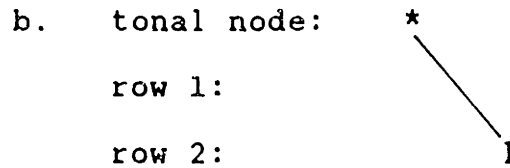

The representation of tone heights in terms of feature trees makes it difficult to interpret the hierarchical property of rows. There are three areas where the hierarchy of rows may meet with difficulty. First, in the tree structure (18) row 1 h and l elements technically do not dominate row 2 elements of h and l. However, row 1 is dominant because it is "higher" on the hierarchy than row 2. Tree structures are ordinarily not able to express Clements's notion of rows. Second, no other phonological features are hierarchical. This makes tone features special within a general theory of features. With the notion of rows, tone features are in effect multi-valued, while features in general are binary. Lastly, features may spread. Given the representation in (18), we expect row 1 and row 2 elements to spread independently. However, if row n elements spread to an adjacent tonal node, does the spreading carry row n+1 elements as well? If row n and row n+1 are sister nodes under the tonal node, row n+1 elements are not expected to spread with row n elements, although they may spread independently of row n elements. But, on the other hand, since row n is dominant over row n+1 on the pitch hierarchy, row n+1 elements necessarily spread with row n

elements, although row $n+1$ elements may spread independently of row n elements. Hence the tree representation of tone heights and the hierarchical nature of rows are incompatible. Nonetheless, the tree representation of features underscores an important insight into the organization of tonal features. Features have internal structure, as various works on segmental features have shown (see Clements (1985a), Sagey (1986), Steriade (1986), Halle (1989), McCarthy (1989a), Trigo (1989), among others). The tree in (18) provides a structured model of tones. In chapter Three, we will use the tree notation to organize the tonal features. The features, however, are strictly binary, and the row hierarchy is abandoned.

2.7 Hyman (1986)

The representation of tones as matrices of tonal features is a common practice in many works, such as Wang (1967), Woo (1969) and Clements (1983) reviewed above. One disadvantage of matrix representation is their inability to express partial assimilation in terms of the spreading of a component tonal feature. Theories which make use of matrices have an inherent weakness as a result. Hyman (1986) departs from this practice. He postulates a single tone feature T , which means "effect a tone modification" (Hyman (1986:115)). The positive value of T (represented as H) effects an upward

Theories of Tone: A Survey

change of one step; the negative value (represented as L) effects a downward change of one step. The feature is arranged hierarchically, as in Clements (1983, 1989), except in Hyman's theory the hierarchical relationship is expressed as dominance on a tree structure. The notion of ordered rows in a matrix is replaced with multiple tiers filled with occurrences of the tone feature T. A four-level system would have the structures in (20):

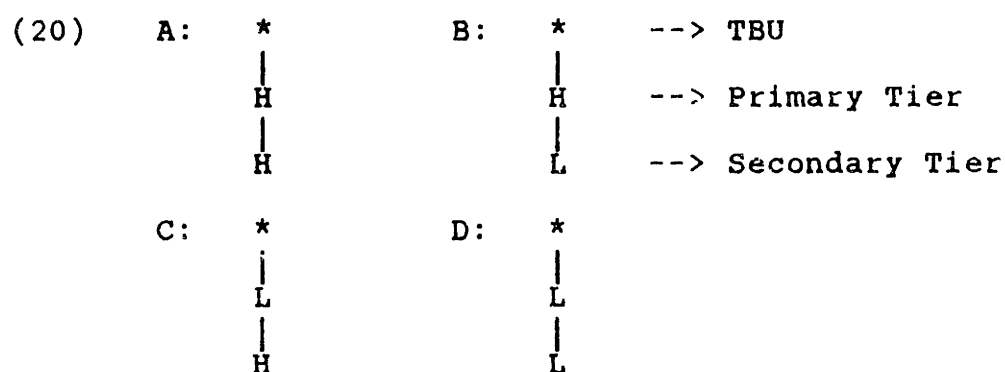

Note that H is [+T] and L [-T]. In the structures in (20), * is the tone bearing unit; the tier which is directly linked to TBUs is the primary tier; its H and L are primary H and L. The tier dominated by the primary tier is the secondary tier, made up of secondary H and L. The number of tiers required apparently depends on the tonal system of the language in question.

The advantage of Hyman's representation over Clements's (1983) matrix representation is the ability to express spreading of the secondary H/L, as shown in (21):

Theories of Tone: A Survey

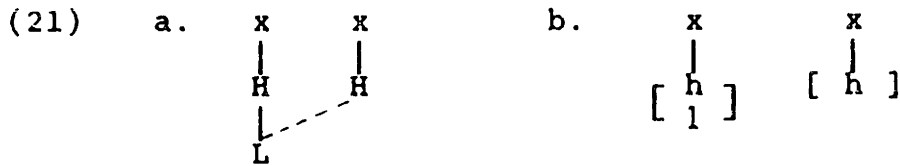

h and l in Clements's theory are equivalent to H and L in Hyman's. l in (21b) can not spread to the following tone because it is bound to the first tonal matrix. Note that the spreading of primary H/L, namely the entire feature specification of a tone, can be expressed in both representations. To the extent that empirical evidence of secondary H/L spreading is attested, Hyman's tier representation is superior to the matrix representation. This model is abandoned in Hyman (1989), to which we will return in §2.10.

2.8 Shih (1986)

The central theme of Shih's (1986) work is the prosodic nature of tone sandhi, rather than the feature representation of tones per se. How tones are represented is related to the theoretic account of their prosodic behavior, therefore a prosodic theory of tones must also address the issue of tonal representation. Exactly how tones are represented by Shih is not entirely clear to me. Shih adopts the register feature [upper] of Yip (1980), but rejects the Tone feature and its sequential properties. In this regard,

she seems to favor the "unitary" approach, meaning that contour tones are units, rather than combinations of level tones or sequences of the Tone feature. This is at least implicit in the "hierarchically organized system" in (22) (Shih (1986:24)):

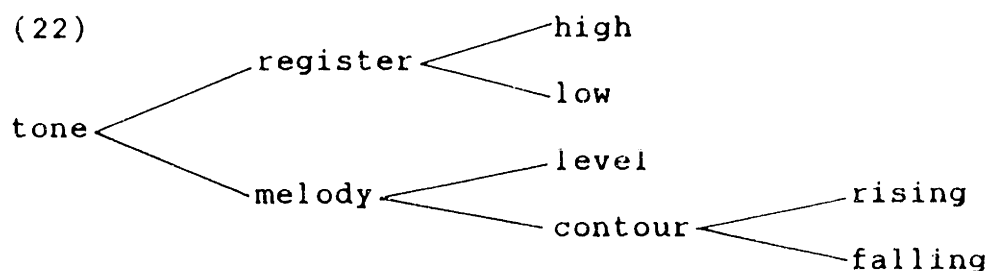

If I read her correctly, this hierarchy postulates pitch contours as part of the theory, and as such, (22) appears to impose some structure on the features of Wang (1967), particularly the contour features. While Wang's features can specify five distinct pitch levels, the tone hierarchy is able to specify two level tones only. No convex or concave tones are on the hierarchy.

But this hierarchy appears to play no theoretical role in Shih's account of some tone sandhi phenomena. She cautions that things like register, contour are not primitive features, but "meta- or macro-features." The difference between features and macro-features, however, is not explained. In formulating rules for the Zhangping bisyllabic tone sandhi, the meta-features are used in the same way features are used. To see this, consider the

Zhangping bisyllabic tone sandhi facts in (23), and the rules in (24) (Shih (1986:24)):

(23) Zhangping

$$(a) \quad \left\{ \begin{array}{l} [24] \\ [11] \\ [21] \\ [55] \end{array} \right\} \text{ ----> } \left\{ \begin{array}{l} [33] / \text{---} \left\{ \begin{array}{l} [22] \\ [11] \\ [55] \\ [53] \end{array} \right\} \\ [55] / \text{---} \left\{ \begin{array}{l} [31] \\ [21] \end{array} \right\} \end{array} \right.$$

$$(b) \quad \left\{ \begin{array}{l} [31] \\ [53] \end{array} \right\} \text{ ----> } [21] / \text{---} X$$

(24)

$$(a) \quad [- \text{fall}] \text{ ----> } \left[\begin{array}{l} \alpha \text{ mid} \\ + \text{ level} \\ - \text{ low} \end{array} \right] / \text{---} [-\alpha \text{ mid}]$$

$$(b) \quad [+ \text{fall}] \text{ ----> } [+ \text{low}] / \text{---} X$$

(24a) accounts for facts in (23a), and (24b) for (23b). We are not concerned with the sandhi facts, but with the rules which account for them. The rules make specific reference to features which occur in the tone hierarchy, such as [fall], [low] and [level], as well as features which do not occur, such as [mid]. Notice that the use of [low] in the two rules suggests that it is used as a feature which, with [high], defines the pitch of the tone. If so, it would appear, contrary to her claim, Shih's conception of register is not the same as that of Yip (1980) at all. Recall that in Yip's system, the Register feature [upper] defines only two pitch registers. The two features [high] and [low] in (22) are

capable of defining three distinct pitch registers (assuming that [+high, +low] is ruled out logically), giving rise to three level tones, and three distinct contour tones as well. In this regard, Shih's theory not only differs from Yip's, but from the theories of Wang (1967) and Woo (1969). Shih is not explicit about the roles of (22) in the specification of tones; it is therefore difficult to pin down its empirical consequences.

2.9 Yip (1989)

Recent research in nonlinear phonology has shifted its focus to the internal organization of phonological features. Most work in this area, among them Clements (1985a), Sagey (1986), Halle (1989) and Trigo (1989), has been on the geometry of supralaryngeal features. Yip (1989) is an attempt to provide a structured model of tone features (see also Inkelas (1987) for a similar model).

The model that Yip (1989) proposes for contour tones parallel the structure of affricates argued for in Sagey (1986). Sagey's representation of affricates involves a sequence of the continuancy feature [cont(inuant)] associated with a single root node, as in (25):

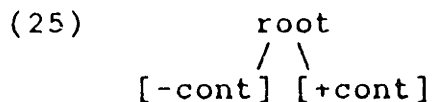

The branching continuancy feature is interpreted linearly along the temporal dimension. This model captures the intuition that affricates involve a change in the state of continuancy: they start as stops ([-cont]) and end as fricatives ([+cont]). Similarly, contour tones can be seen as resulting from a change in pitch during the temporal span of the tone bearing units on which the tones are realized. Using the two features [upper] and [raised] of Yip (1980) and Pulleyblank (1986), Yip proposes that the register feature [upper] be the tonal root node, which dominates a possibly branching [raised]. The high falling tone, for instance, has the representation as in (26):

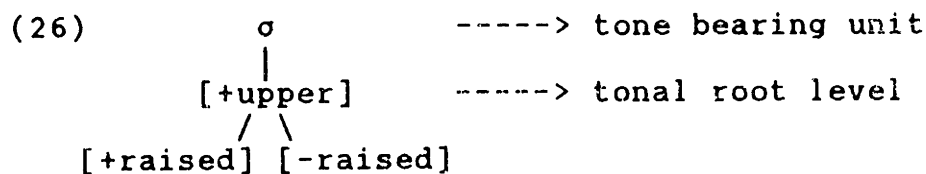

This use of the feature [upper], however, differs from that of Sagey (1986) and Halle (1989), among others. In the works cited, terminal nodes are features. Nonterminal nodes such as PLACE are articulators. Articulator nodes dominate features which represent the articulatory behavior of the articulators. Features therefore do not dominate other features. In this regard Yip's model is similar to Hyman's model in (20), in which the terminal node of T on the primary tier dominates another terminal node on the

secondary tier. In terms of the representation of tones, (26) differs from Yip's earlier treatment of contour tones in that the register [upper] and Tone [raised] now form one single melodic unit, which is associated with a TBU. In Yip (1980), the register and Tone are considered as two distinct autosegments associated with a single TBU (cf. §2.5).

2.10 Hyman (1989)

Hyman's recent work markedly differs from his 1986 study (see §2.7). Hyman (1989:2) proposes two tone features defined below:

(27) Tone features:

H = at or above a neutral tone height

L = at or below a neutral tone height

The neutral reference tone height is the M(id) pitch. The features are related to one another in the tone geometry shown in (28):

(28) TBU: μ
Tonal root node (TRN): o
Tonal node (TN): o

The features H and L link to the TN; which may be optionally branching. The sequences LH and HL merge to define M. The system generates therefore three level tones:

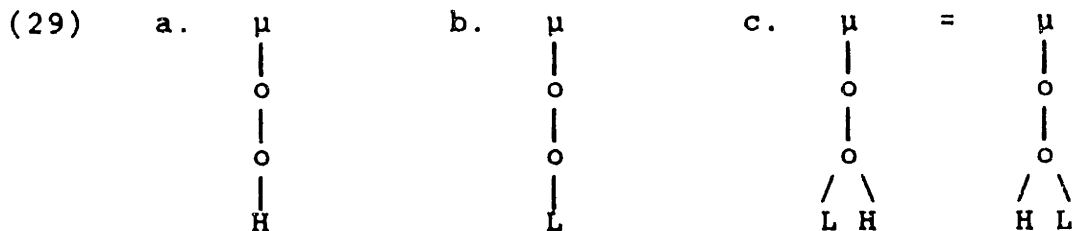

Contour tones are represented as concatenations of level tones. The rising and falling tones are given by Hyman (1989) as follows:

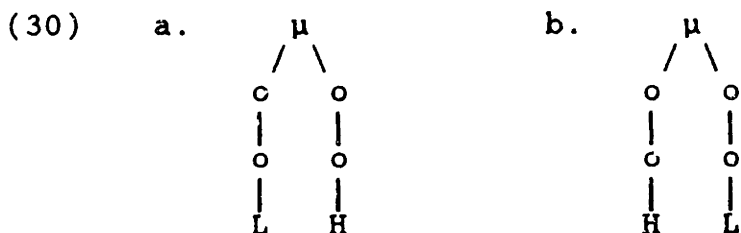

The tonal geometry in (28) is augmented further by what Hyman calls the R-plane (the register plane). The features which link to the TNs form the T-plane (the tonal plane). The register plane is specified by the same two tone features H and L, plus a zero value. In all a total of nine levels may be generated, as the following table show:

(31)

T-plane:	H	L	LH	H	L	LH	H	L	LH
R-plane:	0	0	0	H	L	LH	H	L	LH
TONE:	H	L	M	H	L	M	↑H	↑L	↑M

Within the tonal geometry, the register-plane features link to the TRNs. The model thus allows three types of structure, as in (32):

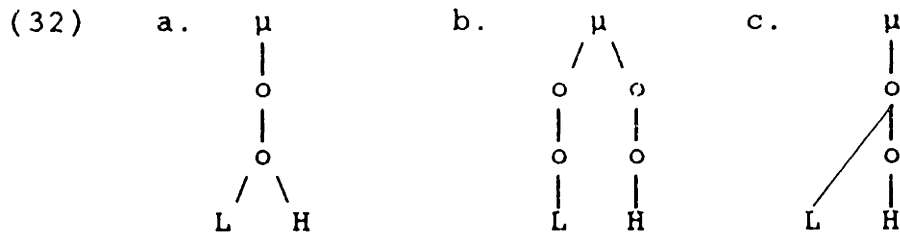

(32a) defines a M tone; (32b) a rising tone; and (32c) a downstep. Since the register feature links to the TRN, Hyman's model differs from that of Yip (1989), in which the register is the TRN (see §2.9). But the notion of register in Hyman's work differs from that in Yip's work in two respects. First, in Yip's model, the register feature is binary, therefore the register is [+upper] (the high register) or [-upper] (the low register). A zero valued register is not permissible featurally and geometrically: the structure in which the sequence of [raised] is dominated by 0 register is not interpretable. Secondly, in Yip's model, the high register dominating the sequence [-raised], [+raised] defines a high rising tone. In other words, the register is a relevant geometrical property not only of level tones but also contour tones. For instance, Yip's model captures the alternation of 53/31 in Songjiang (cf. (2)) as follows:

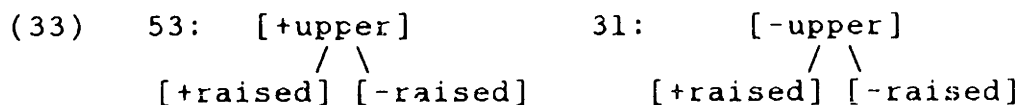

The two falling tones 53 and 31 alternate on their registers. In Hyman's model, however, contour tones can not in principle alternate on the register, as the structures in (34) show:

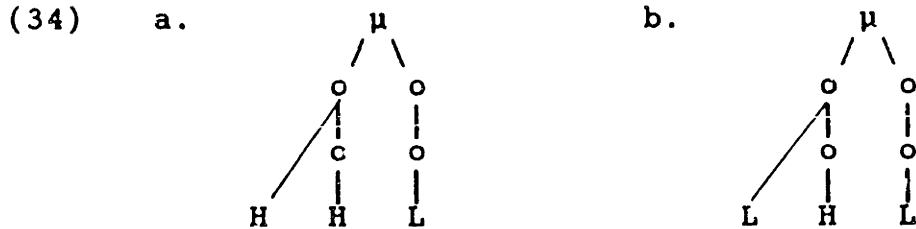

(34a) is the structure of an upstepped H followed by a L; (34b) is the structure of a downstepped H followed by a L. The register does not affect the second TRN in both structures. 53 and 31 may best be represented in Hyman's model as HM and ML respectively. But these representations do not reflect the fact that 53 and 31 alternate on the register conditioned by syllable-initial voicing, and the fact that the differential between the start and end points of the tones remains constant while the register changes. It has the same problems as any cluster model of contour tones (see §2.4).

2.11 Halle and Stevens (1971)

The last feature system we will consider is proposed by Halle and Stevens (1971). Two properties of the Halle-Stevens' feature system need to be emphasized, since they play a crucial role in the theory of tone to be developed in Chapter Three. The feature systems examined in the preceding are mostly based on auditory impressions; Halle-Stevens' system is articulatory. The features they posit do not describe auditory impressions of pitch; but rather provide articulatory instructions to the relevant articulators for the actualization of pitch (i.e. tone). The second important property of the Halle-Stevens system is that it treats voicing in consonants and pitch in vowels as featurally the same phenomenon. The tonal features proposed in various theories lack a phonetic basis, partly because the phonetic mechanism of pitch control is poorly understood (see, for instance, Maddieson (1974), Fujimura (1977, 1981), Ohala (1972, 1977), Stevens (1977, 1981), Sawashima and Hirose (1983), Collier and Gelfer (1984)). However, despite the fact that many factors are involved in pitch regulation, there is linguistic evidence (see the tonal inventory of Songjiang in (2)) that correlates the voicing of consonants and the pitch of the following vowels (see Haudricourt (1954), Halle and Stevens (1971), Matisoff (1973), among others). This correlation is not captured in a theory that

makes use of tonal features unrelated to voicing. Halle-Stevens's system captures this correlation by using the same set of laryngeal features for both vowel pitch and consonant voicing (but see Gandour (1974)). In other words, laryngeal musculature whose activities lead to voicing in consonants is also responsible for pitch in vowels. Vowel pitch and consonant voicing are the same laryngeal phenomenon.

The four laryngeal features which Halle and Stevens (1971) propose are based on two independently controllable parameters, "the stiffness of the vocal cords, and the static glottal opening. (p.201)" The parameters are controlled by intrinsic laryngeal muscles. The description of the features is in (35) (Halle and Stevens (1971:201-202)).

(35)

Spread glottis. By rotation and displacement of the arytenoid cartilages, the vocal cords can be displaced outward relative to their positions for normal voicing, leaving a large glottal width. If the vocal-cord stiffness is sufficiently large, the combination of wide glottis and stiff glottal walls inhibits vocal-cord vibration. On the other hand, slackening of the glottal walls by reducing the stiffness can lead to a condition in which vocal-cord vibration will occur, even with a relatively wide glottal opening.

Constricted glottis. Adduction of the arytenoid cartilages relative to the position for normal voicing (accomplished, perhaps, by fibers of the thyroarytenoid muscles, as well as by the lateral cricoarytenoid muscles) can cause the vocal cords to be pressed together and the glottis to narrow or to close. When the vocal-cord stiffness is large in this situation, vocal-cord vibration does not occur, and no air passes

through the glottis. For a lower coupling stiffness, vocal-cord vibration can be initiated, probably with relatively narrow, peaked pulses.

Stiff vocal cords. Increasing the stiffness of the vocal cords makes the coupling between upper and lower edges of the vocal cords larger. Stiffening of the vocal cords affects glottal vibration, regardless of the size of the glottal aperture. When the vocal cords are in a configuration for normal voicing (neither spread nor constricted), the rate of vocal-cord vibrations increases with increasing stiffness. Increased stiffness of the vocal cords will inhibit vocal-cord vibration under the following circumstances: (a) when an obstruction in the vocal tract causes the intraoral pressure to build up and hence the pressure across the glottis to decrease; (b) when the glottis is spread to cause a wide aperture or when it is constricted. Thus an increased stiffness of the vocal cords tends to narrow the range of transglottal pressures and glottal apertures over which vocal-cord vibration occurs.

Slack vocal cords. The vocal cords can be made more slack by decreasing the coupling between upper and lower edges of the vocal cords. This is probably accomplished by a decrease in the tension of the vocal cords, as well as by a decreased stiffness of the walls of the glottis. Slackness of the vocal cords can allow glottal vibration to occur even with a spread or constricted glottis. When the vocal cords are slackened, there is a decrease in the frequency of glottal vibration.

Two laryngeal features, [stiff vocal cords] and [slack vocal cords] (henceforth [stiff] and [slack]) are primarily responsible for pitch of vowels and voicing of consonants. The two vocal cord features define three states of vocal cord tension, their effects on obstruents and vowels are listed below:

Theories of Tone: A Survey

(36)	vowels	M	L	H
	obstruents	b ₁	b	p
	stiff	-	-	+
	slack	-	+	-

The feature combination [+stiff] and [+slack] is ruled out on logical and physiological grounds, since the vocal cords can not be both stiff and slack at the same time. Notice that voiced obstruents share the same feature matrix as low pitch vowels, and voiceless obstruents share the same feature matrix with high pitch vowels. This readily accounts for the lowering effect of voiced consonants on the pitch of the following vowel found in many tone languages.

Halle-Stevens's system provides for three distinct vocal cord states which correspond to three distinct pitch levels. A common criticism of the Halle-Stevens system is that it provides only three pitch levels, which is not sufficient (Fromkin (1972), Anderson (1978), Yip (1980)). In Chapter Three I will re-interpret the features [stiff] and [slack] as features which are independently controllable. The feature combination [+stiff] and [+slack] is permissible. A total of four pitch levels are specified with two features [stiff] and [slack].

Chapter Three

The Representation of Tone

3.1 The Geometry of Tone

The tone model which I will propose and argue for makes use of the two binary features of Halle and Stevens (1971), [stiff] and [slack]. As I have pointed out in §2.11, the advantage of the Halle-Stevens' feature system is its ability to express the pitch of vowels and voicing of consonants as featurally the same phenomenon. Thus, [+stiff] specifies voicelessness in consonants, and relatively high pitch in vowels, and [-stiff] specifies voicing in consonants, and relatively low pitch in vowels. This captures directly the well-known correlation between tone registers (the yin/yang registers) and the voice qualities of consonants. Under the interpretation of Halle and Stevens (1971), the feature [stiff] provides the articulatory instruction to raise the degree of stiffness of the vocal cords; while the feature [slack] gives the opposite instruction. The two features combine to determine three states of vocal cord tension, which produces three distinct pitches:

The Representation of Tone

(1)	H	M	L
stiff	+	-	-
slack	-	-	+

[+stiff] and [+slack] are thought to be mutually exclusive on logical and physiological grounds.

By Halle and Stevens's account, the two features are not identified with any laryngeal muscle, whether intrinsic or extrinsic. Unlike the feature [nasal], which provides the articulatory instructions to the soft palate (Sagey (1986)), the features [stiff] and [slack] must rely for their phonetic execution on muscle complexes whose activities affect in one way or another the tension of the vocal cords. To rule out [+stiff,+slack] on logical and physiological grounds, one must assume that [stiff] and [slack] are executed by the same set of muscles -- [+stiff] stiffens the vocal cords while [+slack] slackens them. This assumption is no more experimentally supported than the assumption that the two laryngeal features are articulatorily executed by different sets of muscles (see §3.5 for further discussion). The latter assumption leads to a different interpretation of the features. The muscular activities of the feature [stiff] can be interpreted as determining the overall tension of the vocal cords, which is subject to modification by the muscular activities regulated by the feature [slack]. Instead of three states, they combine to produce four states

The Representation of Tone

of vocal cord tension. The two features have different functions. Their interaction gives rise to four distinct pitch levels:

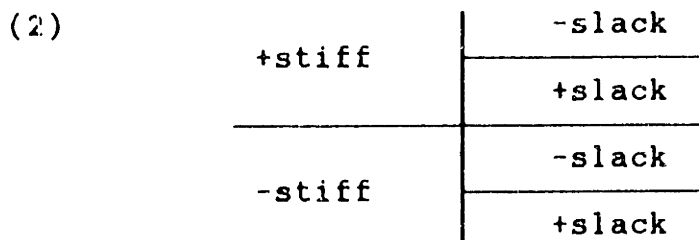

The features [stiff] and [slack] are functionally equivalent to [upper] and [raised] of Yip (1980) and Pulleyblank (1986). The feature [stiff] specifies two registers, each of which is divided by the feature [slack] into two subregisters. Following Yip (1980,1989), I assume that two specifications of the feature [slack] may occur in sequence under the same tonal node. The sequence is temporally significant and is directly dominated by what I call the c node. The c node specifies the tonal contour. The register and the c node are dominated by the tonal root node, denoted by t. The geometry of tone is shown in (3):



The register (the r node) is either H ([+stiff]) or L ([-stiff]). The contour (the c node) may optionally branch. When it branches, it has the structure shown in (4):

$$(4) \quad \begin{array}{c} c \\ / \quad \backslash \\ [\alpha \text{ slack}] \quad [-\alpha \text{ slack}] \end{array} \quad \text{where } \alpha = + \text{ or } -$$

A tone therefore consists of two components: the register and the contour, represented by the r node and the c node respectively. The register specifies the relative pitch height for the tone, while the c node specifies how the tone behaves over the duration of the tone bearing unit. The two notions, register and contour, are familiar ones in the literature. The r node is functionally equivalent to the traditional notion of the yin/yang registers (cf. §2.1); the Register autosegment of Yip (1980) (cf. §2.5); the primary tier of Hyman (1986) and register of Hyman (1989) (cf. §2.7 and §2.10); row 1 of Clements (1983, 1989); the tonal root node of Yip (1989) (cf. §2.9).¹

The novel feature about the tone model in (3) lies in the conception of register and contour, and the structural relationship between the two notions. Structurally the r node and the c node are sister nodes dominated by the tonal root node t. The relation of temporal precedence is irrelevant between the two sister nodes. The two structures below are formally equivalent:

1. Lin and Repp (1989) report that in Taiwanese, F_0 height and movement are the most important factors in tonal perception. Among tones with the same or similar contour, the F_0 height (i.e. the register) is the most prominent; among tones with the same or similar register, the F_0 movement (i.e. contour) is the most prominent factor.

The Representation of Tone

- (5) a. $\begin{array}{c} t \\ / \quad \backslash \\ r \quad c \end{array}$ b. $\begin{array}{c} t \\ / \quad \backslash \\ c \quad r \end{array}$

Conceptually they are distinct. The r node is static in the sense that it provides the overall pitch register which is relatively stable throughout the duration of the tone bearing unit. Since it specifies the pitch register in which the tone is to be realized, the r node must be either L or H. The c node is dynamic; and is interpreted over time. A branching c node is temporally significant: the sequence [-slack] followed by [+slack] involves a change from the high end to the low end of the register specified by the r node, creating a falling contour. A rising contour involves a change from [+slack] to [-slack]. A non-branching c node (an even contour) maintains the same pitch level during the temporal span of the tone bearing unit. I make the following stipulation:

- (6) Underlyingly, the contour node may have at most two branches

This stipulation constrains the number of tones that the model in (3) can generate. It is necessary because no tone has the contour rise-fall-rise, which is the sequence [+slack][-slack][+slack][-slack] or the contour fall-rise-fall, i.e. the sequence [-slack][+slack][-slack][+slack]. If the c node is not so constrained, such non-occurring tonal

The Representation of Tone

contours would be expected to occur. The stipulation (6) implies the proposition in (7):

(7) Concave/convex contours are surface phenomena

In §3.4.2 I will show that at least two dialects which exhibit surface complex contours can be analyzed without postulating the complex contours as underlying. (6) makes the correct empirical prediction.

The tonal geometry proposed in (3) generates two registers and three contours, for a possible inventory of eight underlying tones:²

(8) a. Even Tones

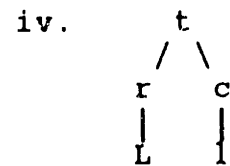
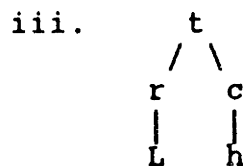
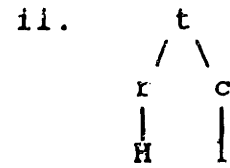
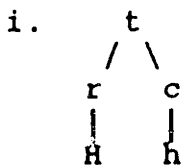

b. Falling Tones

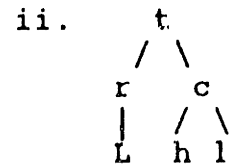
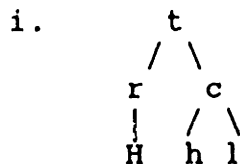

2. For ease of exposition I use upper-case H and L for register and lower-case h and l for contour. They are defined as follows: H=[+stiff], L=[-stiff], h=[-slack] and l=[+slack].

The Representation of Tone

c. Rising Tones

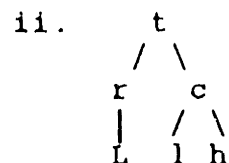
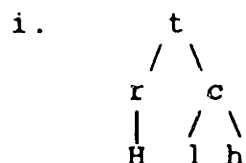

In (8a) I use the word "even" to denote the pitch contour resulting from a non-branching c node. The word "level" is used to refer to points on the pitch scale. The even, falling and rising contours are the three possible underlying contours that the model allows. The structures below are equivalent to the ones in (8):

(9) a. Even Tones

- i. [H,h]
- iii. [L,h]

- ii. [H,l]
- iv. [L,l]

b. Falling Tones

- i. [H,hl]

- ii. [L,hl]

c. Rising Tones

- i. [H,lh]

- ii. [L,lh]

It has often been observed that voicing of obstruents and the pitch of vowels are related (see, for example, Haudricourt (1954), Halle and Stevens (1971), Matisoff (1973)). The correlation between voicing and tone height can be seen clearly in the tonal inventory of Songjiang (Jiangsu...(1960)):

The Representation of Tone

(10) Tonal Inventory of Songjiang

yin-register

- | | | |
|----|-----------------|---------------------------|
| a. | 53 (Even): | ti "low"; t'i "ladder" |
| b. | 44 (Rising): | ti "bottom"; t'i "body" |
| c. | 35 (Departing): | ti "emperor"; t'i "tear" |
| d. | 5 (Entering): | pa? "hundred"; p'a? "tap" |

yang-register

- | | | |
|----|-----------------|--------------|
| A. | 31 (Even): | di "lift" |
| B. | 22 (Rising): | di "brother" |
| C. | 13 (Departing): | di "field" |
| D. | 3 (Entering): | ba? "white" |

(5 and 3 are short tones realized only on syllables ending in the glottal stop.) In the data in (10), both aspirated and unaspirated voiceless obstruents occur only with high tones (the yin-register tones), and voiced obstruents only with low tones (the yang-register tones).³ Songjiang's tonal inventory is a paradigm case which exhibits the direct correlation between the voicing qualities of syllable-initial obstruents and the tonal registers (the r node): if the syllable-initial obstruent is voiced ([-stiff]), the register of the tone on the vowel is low ([-stiff]), if it is voiceless ([+stiff]), the register is high ([+stiff]). The tones of Songjiang can be represented in (11):

3. (10a,A,b,B) and (10C,D) are used in sonorant-initial syllables. See Appendix for the sound system of Songjiang.

The Representation of Tone

(11) Tone Inventory of Songjiang

Falling Tones:

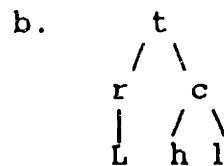
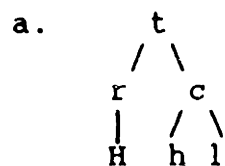

Even Tones:

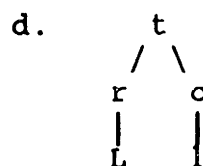
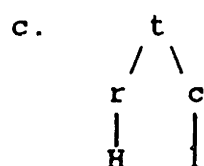

Rising Tones:

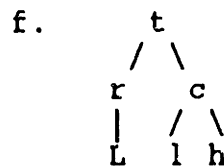
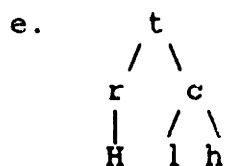

In the structures in (11), the r nodes need not be specified, since they are predictable from the syllable-initial obstruents. I include the registers for clarity. The short tones 5 and 3 are not distinctive, and are derivable from the falling tones (11a,A). The tone inventory of Songjiang makes full use of the contours that the proposed theory provides: the falling contour, the even contour and the rising contour.

The geometry of tone features proposed here makes several claims about possible tone sandhi processes. Specifically, it predicts the four kinds of assimilation by spreading shown in (12) (stars are tone bearing units):

The Representation of Tone

- (12) a. Tone Spread b. Register Spread

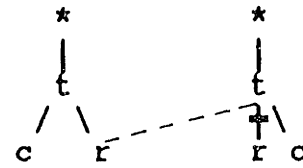
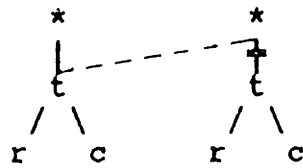

- c. Contour Spread d. Feature Spread

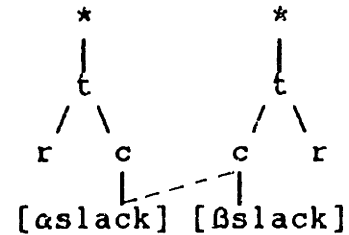
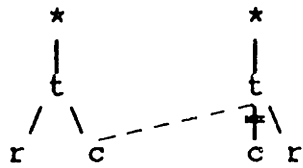

In (12a), the entire tone structure spreads as a melodic unit, whether it is a level tone or contour tone. This is not expressible in theories such as Woo (1967) and Hyman (1989), which treat contour tones as clusters of level tones. Since the r node and the c node spread together, the tone spreading phenomenon exemplified in (12a) supports the geometry of tone in which the r node and the c node are sister nodes dominated by the tonal root node t. In (12b), the register node spreads without affecting the contour. This phenomenon can not be explained in Yip's (1989) theory, in which the register dominates the sequence of the feature [slack] (i.e. the c node). In Yip's theory, spreading the register automatically takes along the contour. In (12c), the contour node spreads without affecting the register, which justifies representing the sequence of the feature [slack] as a separate node, namely the c node. In other

The Representation of Tone

words, a structure in which the features [stiff] and [slack] are sister nodes, as shown in (13), will fail to account for the phenomenon of contour spreading.

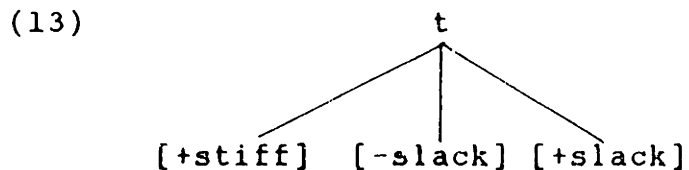

The fourth possibility of assimilatory spreading is illustrated in (12d), in which a single feature spreads. This kind of spreading involves a terminal node dominated by the \dot{c} node, and differs from contour spreading, which involves the nonterminal c node.

We now proceed to show that the theoretical predictions are borne out empirically.

3.2 The Motivation of Underlying Contour

It is not obvious that contour must be present in the underlying representation. Intuitively, a contour is created if two tones of different pitch are placed next to each other on the same tone bearing unit. The default assumption is that such an abstract notion of contour (as represented by the c node in (3)) does not exist at the underlying level (cf. Woo (1969), Pulleyblank (1986), Duanmu (1990), among others). Any postulation of underlying contour must be empirically motivated. One motivation comes from the

The Representation of Tone

consideration of the tonal inventory of a tone language. Given the two tone features [stiff] and [slack], we can account for four tones at the underlying level. The system fails if there exists a language which has more than four distinctive tones in its tonal inventory. When we consider such tone inventories, we must pay attention to factors such as the relationship between voicing qualities of syllable-initial obstruents and pitch height of tone, as well as the structure of the syllable on which tones are realized. Consideration of tone inventories of languages which do not show a correlation between consonant voicing and tone pitch leads to the conclusion that contours must be represented at the underlying level. Weining Miao, a dialect of Miao spoken in Weining, Guizhou Province, is a language with such a tone inventory. Weining Miao has seven tones, as in (14) (F.-S. Wang (1957)):⁴

(14)	a. 55	ku "I"	b. 33	ko "root"
			c. 11	ku "be"
	d. 53	ly "willow"	e. 31	la "friend"
	f. 35	v'ae "that"	g. 13	v'ae "grab"

As the data in (14) show, the tones can not be reduced on the basis of syllable-initial consonants, since there is

4. The values given in (14) must be understood in a relative sense. F.-S. Wang (1957:121) notes that when pronounced, 35 is 24, 13 is 12, 33 is 44, 11 is 22, and 31 is 21. But Li and et al (1959) gives the same tonal values as (14).

The Representation of Tone

no correlation between consonant voicing and tone pitch. The voiceless consonant /k/ occurs with both the high even 55, the mid even 33, and the low even 11 (cf. (14a,b,c)); and the voiced aspirated consonant /v'/ occurs with both the high rising 35 and the low rising 13 (cf. (14f,g)). The same is true of the two falling tones (cf. (14d,e)).

The distribution of tones in the inventory of Weining Miao furnishes evidence that the falling and rising contours which we see in the citation tones can not be reduced to underlying level tones, unless we introduce more features to supplement [stiff] and [slack]. Supplemental features are not necessary if we allow the [slack] feature to occur in sequence, as suggested by Yip (1980, 1989). Any system which employs two binary features must allow contour to be represented underlyingly.

3.3 Assimilation in Tone Sandhi

3.3.1 Tone Assimilation

3.3.1.1 Danyang

Danyang, a Wu dialect spoken in the province of Jiangsu, has been discussed in M. Chen (1986b), Yip (1989) and Chan (1989). These works are based on the original paper of Lü (1980), from which I draw my data. Danyang has six surface tones in citation form, as in (15) (The original

The Representation of Tone

data are given in characters; the transcription used here is in Pinyin, except the glottal stop in square brackets):

- (15)
- | | | |
|----|----|----------------------------|
| a. | 11 | lan "rotten" |
| b. | 33 | wang "net"; gao "high" |
| c. | 24 | fang "house"; dao "arrive" |
| d. | 55 | tu "earth" |
| e. | 3 | yi[ʔ] "one" |
| f. | 4 | fu[ʔ] "coat" |

Unlike most Wu dialects, Danyang does not have voiced and voiceless contrast except in fricatives. The tones in (15) do not show the effect of syllable-initial voicing, as is the case with dialects which maintain the voiced and voiceless contrast among obstruents. (15e,f) are short tones, realized on syllables ending in the glottal stop.

There are six bisyllabic tone melodies in this dialect, which are enumerated in (16):

- (16)
- | | | |
|----|--------|---|
| a. | 11-11: | shi zi "persimmon"
di yu "hell"
jiu jiu "uncle" |
| b. | 42-11: | ji dan "chicken egg"
ming ci "noun" |
| c. | 42-24: | nu er "daughter"
jie mei "sister"
zhi tou "finger" |
| d. | 33-33: | lao hu "tiger"
mo li "jasmine" |
| e. | 24-55: | peng you "friend"
pi xie "leather shoe"
niang jiu "uncle" |

The Representation of Tone

- f. 55-55: nan men "south gate"
 che zhan "station"
 yi niang "aunt"

We will not be concerned with the relationship between the lexical tones and the phrasal bisyllabic tone patterns. Suffice it to say that the tone melody of a phrase depends on the historical origin of the initial syllable of the phrase, rather than its tone. It is not possible to derive the phrasal tone melodies from the lexical tones of the component syllables. M. Chen (1986b) calls the phrasal tone melodies "word melodies." Consider now the word melodies of trisyllabic phrases in (17):

- (17) a. 11-11-11:
 lan [shi zi] "rotten persimmon"
 11-11
 huo [di yu] "living hell"
 11-11
 b. 42-11-11:
 sheng [ji dan] "raw chicken egg"
 42-11
 san [nu er] "third daughter"
 42-24
 xin [ming ci] "new noun"
 42-11

The Representation of Tone

- c. 42-42-24:
hao [peng you] "good friends"
24-55
qi [jie mei] "seven sisters"
44-24
qi [yi niang] "seventh aunt"
55-55
qi [jiu jiu] "seventh uncle"
11-11
- d. 33-33-33:
pi [lao hu] "leather tiger"
33-33
si [nu er] "fourth daughter"
42-24
- e. 24-55-55:
nan [peng you] "boyfriend"
24-55
huang [pi xie] "yellow leather shoe"
24-55
- f. 55-55-55:
xin [nan-men] "new south gate"
55-55
dong [che-zhan] "east station"
55-55

Syntactically, phrases which exhibit the tone patterns in (17) are of the form [x [y z]], as the data indicate. Phrases with the syntactic structure of the form [[x y] z] have their own tone patterns, which we will not discuss here. The tone patterns beneath the bracketed phrases are the patterns for the bisyllabic patterns when they are not a

The Representation of Tone

constituent of a trisyllabic phrase. Note that the bisyllabic phrase *peng you* "friend" has the tone pattern 24-55 (cf. (16e)), but *nan* [*peng you*] "boyfriend" surfaces as 24-55-55 and *hao* [*peng you*] "good friend" as 42-42-24. Similarly, *qi* [*yi niang*] "seventh aunt", *qi* [*jiu jiu*] "seventh uncle", and *qi* [*jie mei*] "seven sisters" all surface as 42-42-24 (cf. (17c)), even though [*yi niang*] "aunt" surfaces as 55-55, [*jiu jiu*] "uncle" as 11-11 and [*jie mei*] "sister" as 42-24. As is the case with bisyllabic word melodies, the trisyllabic word melodies are determined only by the initial syllable of the phrase.

Phrases with four syllables display the same tone patterns, as shown in (18):

(18) a. 11-11-11-11:

jiu [*yang mao shan*] "old woolen sweater"
old sheep hair shirt
55-55-55

da [*shou yin ji*] "big radio"
big receive sound machine
55-55-33

b. 42-11-11-11:

xin [*yang san yu*] "new sweet potato"
new foreign potato
24-55-55

zhen [*jin jie-zhi*] "real gold ring"
real gold ring
42-11-11

The Representation of Tone

c. 42-42-42-24:

[ke ke qi qi] "polite"
(reduplicated from ke qi, "polite")

d. 33-33-33-33:

ye [bai ju-hua] "wild white mum"
wild white mum
11-11-11

fu [zhong zhi-hui] "deputy chief"
deputy chief commander
33-33-33

e. 24-55-55-55:

[ming ming bai bai] "clear"
(reduplicated from ming bai, "clear")

f. 55-55-55-55:

xian [mi xian zhou] "salty rice gruel"
salty rice flour gruel
33-33-33

Like bisyllabic and trisyllabic tone patterns, quadrisyllabic tone patterns are determined by the historical origin of the initial syllable. The patterns are juxtaposed below for easy inspection:

(19)	Bisyllabic	Trisyllabic	Quadrisyllabic
a.	11-11	11-11-11	11-11-11-11
b.	42-11	42-11-11	42-11-11-11
c.	42-24	42-42-24	42-42-42-24
d.	33-33	33-33-33	33-33-33-33
e.	24-55	24-55-55	24-55-55-55
f.	55-55	55-55-55	55-55-55-55

The Representation of Tone

Descriptively, the polysyllabic tone patterns in (19a,b,d,e,f) can be seen as derived from the corresponding bisyllabic patterns by left-to-right association and the spreading of the second tone. (19c), however, can not be derived in this fashion. Instead, it can be derived by right-to-left association and the spreading of the first tone, as illustrated by the derivations of the quadrisyllabic patterns in (19b,c) below:

(20) a. Derivation of Pattern (19b)

Base Melody: 42 11

Left-to-Right Association

*	*	*	*
42	11		

Left-to-Right Spreading

*	*	*	*
42	11	11	11

b. Derivation of Pattern (19c)

Base Melody: 42 24

Right-to-Left Association

*	*	*	*
		42	24

Right-to-Left Spreading

*	*	*	*
42	42	42	24

The Representation of Tone

The pattern (19c) have generated a great deal of interest in recent work on the phonology of tones, which I will sketch briefly. M. Chen (1986b:12) takes the Danyang data as suggesting that "the directionality of tone mapping may be lexically marked." Yip's (1989) analysis leads to the same conclusion. In her analysis, the bisyllabic pattern [42 24] is the base melody from which the polysyllabic tone patterns in (19c) are derived by means of the edge-in association and left-to-right spreading. Her derivation of the quadri-syllabic pattern in (19c) is as follows:

(21) Base Melody: 42 24

Edge-In Association



Initial Tone Spreading, Left-to-Right

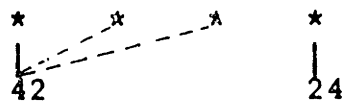

Tier Conflation

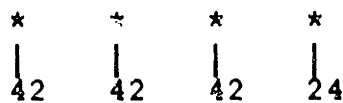

Although Yip (1989) does not address the issue, the question of directionality of spreading arises in her analysis. Only (19c) is derivable by left-to-right spreading of the initial tone of the base melody. The rest of the

The Representation of Tone

polysyllabic patterns in (19) can be derived only by right-to-left spreading of the final tone, as illustrated by the derivation of the quadrisyllabic pattern in (19b):

(22) Ease Melody: 42 11

Edge-In Association

* * * *
 | | | |
 42 | | 11

Final Tone Spreading, Right to Left

* * * *
 | | | |
 42 | | 11

Tier Conflation

* * * *
 | | | |
 42 11 11 11

Chan's (1989) analysis circumvents the problem of directionality of association. Following an observation made by Lü (1980:88) to the effect that in strings with two consecutive 24s, the first 24 becomes 42, Chan assumes that the base melody of the patterns in (19c) is LH, which spreads as a unit across a polysyllabic phrase. The quadrisyllabic pattern is derived as follows (o is the tonal root node of Yip (1989), cf. §2.9):

The Representation of Tone

(23) Tone Melody: LH

Association and Tonal Spreading, Left to Right:

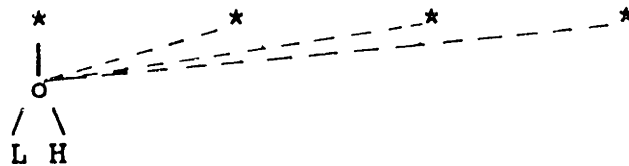

Tier Conflation, Contour Formation

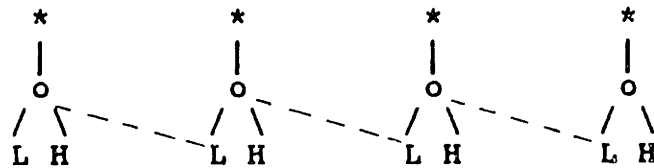

Simplification (delinked L does not surface):

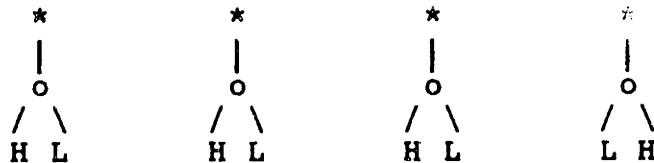

The rule of Contour Formation creates a tonal root node which dominates LHL, to which the rule of Simplification applies to delete the leftmost branch. Other patterns in (19) can be derived by left-to-right association and spreading. Thus, the issue of directionality of association and spreading does not arise.

In the preceding I summarized in general terms three analyses of the Danyang data. The analysis I give below follows Lü (1980) and Chan (1989). According to Lü (1980), the tone patterns of trisyllabic and quadrisyllabic phrases are extensions of their corresponding bisyllabic tone patterns. In the terminology of nonlinear phonology,

The Representation of Tone

polysyllabic tone patterns are derived by the left-to-right spreading of the rightmost tone of a base melody. This is true of all cases except (19c). But the patterns in (19c) turn out to be the surface manifestation of underlying patterns which can be derived in the same way as the rest of the patterns. As noted earlier, in strings of two consecutive 24s, the first 24 dissimilates to 42 (Lü (1980:88)). Recall that the tone 42 does not occur in citation form. To formally characterize the dissimilatory process, I assume that 24 and 42 are both H-registered, and have the following structures:

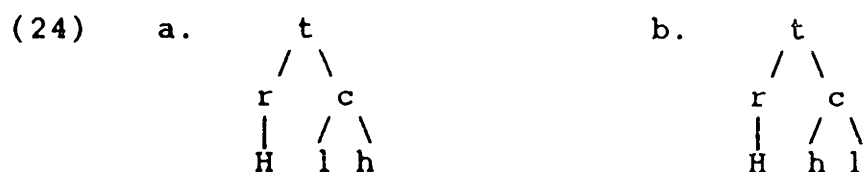

Contour dissimilation can be viewed as metathesis of the c node. The metathesis rule is given in (25):

(25) Contour Metathesis:

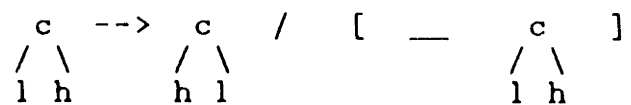

Contour Metathesis (25) applies to strings of the form 24-24, yielding 42-24. The intermediate representations of the tone patterns in (19c) are therefore 24-24, 24-24-24 and 24-24-24-24, respectively. The dissimilation rule (25)

The Representation of Tone

applies from left to right, deriving the surface tone patterns of 42-24, 42-42-24 and 42-42-42-24.

As we have noted earlier, the phrasal tone patterns in (19) are completely determined by the phrase-initial syllable. It is thus reasonable to assume six basic word melodies from which the polysyllabic tone patterns are derived. The word melodies are given in (26) (the numerical notation is in parentheses):

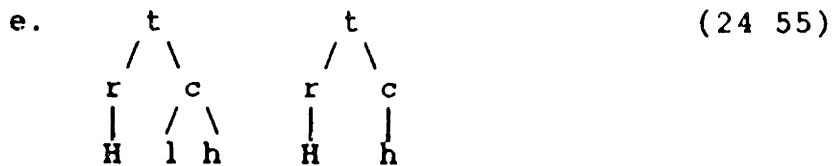
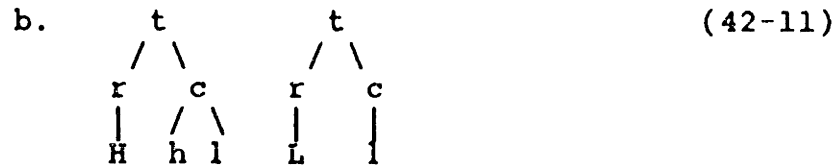



Phrases select their tone melodies from (26) in terms of their initial syllables. The polysyllabic tone patterns can be derived in the following steps:

- (27)
- a. Delete lexical tones
 - b. Associate left to right the base tone melodies to tone bearing units
 - c. Spread last tone rightward to unlinked tone bearing units
 - d. Contour Metathesis (25)

The following derivations of the quadrisyllabic patterns of (19b,c) illustrate how (27) works (t_1 through t_4 are lexical tones):

The Representation of Tone

(28) Phrases with Base Tone Melody 42 11 (26b)

t_1 t_2 t_3 t_4
 \downarrow \downarrow \downarrow \downarrow
 $*$ $*$ $*$ $*$

[H,h1] [L,l]

Delete lexical tones/Associate base tone melody

$*$ $*$ $*$ $*$
 \downarrow \downarrow
[H,h1] [L,l]

Spreading

$*$ $*$ $*$ $*$
 \downarrow \downarrow \downarrow \downarrow
[H,h1] [L,l] [L,l] [L,l]

Phrase with Base Tone Melody 24 (26c)

t_1 t_2 t_3 t_4
 \downarrow \downarrow \downarrow \downarrow
 $*$ $*$ $*$ $*$

[H,lh]

Delete Lexical Tones/Associate Tone Melody

$*$ $*$ $*$ $*$
 \downarrow
[H,lh]

Spreading

$*$ $*$ $*$ $*$
 \downarrow \downarrow \downarrow \downarrow
[H,lh] [H,lh] [H,lh] [H,lh]

Contour Metathesis (27e)

$*$ $*$ $*$ $*$
 \downarrow \downarrow \downarrow \downarrow
[H,h1] [H,h1] [H,h1] [H,lh]

(42 42 42 24)

The Representation of Tone

Other tone patterns in (19) can be derived in the same way.

The derivation of the melodies in (28b) embodies an important property concerning contour tones: the register and contour spread together as a unit. In addition, as pointed out by M. Chen (1986b:12), the Danyang data of phrasal tone patterns, particularly (19c), indicate that contour tones are referred to as indivisible units by certain rules, which poses great difficulty for any theory which treats contour tones as concatenated of level tones with no internal structure.

3.3.1.2 Changzhi

Another dialect of Chinese which exhibits the phenomenon of tone spreading is Changzhi, spoken in the Province of Snaanxi in central China. Changzhi has six tones in citation form, as shown in (29) (all Changzhi data are taken from J.-Y. Hou (1983)):

(29)	a. 213	ts'əu "suck";	paŋ "spotted"
	A. 24	ts'əu "thick";	p'aŋ "plate"
	b. 535	ts'o "weed";	pu "cloth"
	c. 44	ts'əu "stinky";	paŋ "half"
	C. 53	tsu "column";	paŋ "stick"
	d. <u>54</u>	tsə? "choose";	pa? "pull"

The underlined tone 54 is a short tone realized in syllables ending in the glottal stop. Changzhi does not have voiced obstruents; the pairs (29a,A) and (29c,C) are distinctive,

The Representation of Tone

as can be seen from the onset obstruents of the data given.

Changzhi has two suffixes *tə?* and *ti*, represented by two characters which have the lexical tone 535 when read in isolation. Syntactically, *tə?* is suffixed to a nominal stem, producing a bi-syllabic noun. The suffix *ti* is attached to an adjectival stem. They do not appear to contribute much to the meaning of their respective stems. Relevant data are given in (30) (in the tone patterns the first tone is that of the stem, the second tone is that of the suffixes):⁵

- (30) a. 213 535 > 213 213
- | | |
|----------|---------|
| ts'ə tə | "cart" |
| ɕiaŋ tə | "trunk" |
| suag ti | "sour" |
| tə'ig ti | "green" |
- b. 24-535 > 24-24
- | | |
|----------|----------|
| xə tə? | "child" |
| luŋ tə? | "wheel" |
| xuag ti | "yellow" |
| ts'əu ti | "thick" |
- c. 535-535 > 535-535
- | | |
|--------|---------|
| paŋ tə | "board" |
| i tə | "chair" |
| ləŋ ti | "cold" |
| yaŋ ti | "soft" |

5. The short tone 54 has two patterns. If the syllable had a voiced initial consonant in Classical Chinese, the tone pattern is the same as 53; if the syllable had a voiceless initial consonant, the tone pattern is 44-44. I will ignore the complication of the short tone.

The Representation of Tone

d. 44-535 > 44-535

tɕiɔ tɕ	should carrier
tɕiɔ tɕ	a kind of rice pastry
ag ti	"dark"
ts'əu ti	"stink"

e. 53-535 > 53-53

ɕiag tɕ?	"fillings"
təu tɕ?	"bean"
lag ti	"rotten"
iɔ ti	"hard"

Note that the nominal suffix tɕ? loses its glottal stop when the tone is either 213 or 535 (cf. (30a,c,d)), suggesting that 213 and 535 form a natural class on account of their contour. Phrases with the two suffixes have exactly the same tone patterns, which are summarized below:

(31)	Stem Tones	Phrasal Tone Patterns
	213	213-213
	24	24-24
	535	535-535
	44	44-535
	53	53-53

With the exception of 44 (30d), all the phrasal tone patterns can be derived from the stems by spreading their tones; hence the data clearly demonstrate the spreading of tones as melodic units. The tone 44 does not present any problem if we assume that its c node and r node are unspecified, as in (32),



and the following default rules supply the unspecified values:⁶

- (33) a. [] --> [-stiff]
 b. [] --> [-slack]

The spreading process involves a fully specified tone. Underspecified tones do not spread. I will defer the discussion of the underlying structures of Changzhi tones until §3.4.2.1, for the present I will continue to use the numerical notation. The derivation of the bisyllabic phrasal tone patterns is illustrated in (34):

6. The two rules in (33) are essentially the default rules Pulleyblank (1986:126) proposes for the features [upper] and [raised]:

- (i) a. V --> V
 |
 [-upper]
 b. V --> V
 |
 [+raised]

Pulleyblank assumes the default rules to be universal. Note that [-upper] corresponds [-stiff] and [+raised] to [-slack].

The reason to treat 44 as a [-stiff] tone is that in verbal reduplication the tone 44 surfaces as the low falling tone 31 in initial position, see §3.4.2.1.

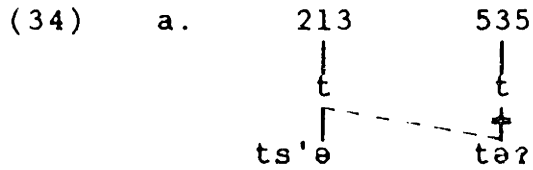

Glottal Deletion

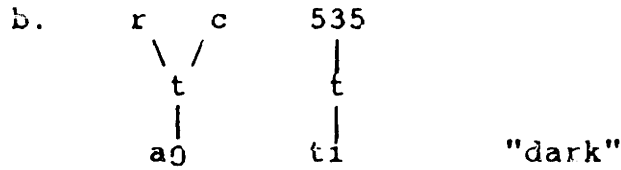
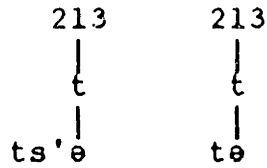

Default Rules (33)

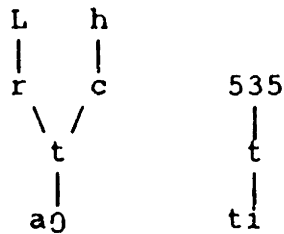

(44-535)

In (34a), the tone of the first syllable spreads to the second syllable, displacing the latter's lexical tone. Spreading does not take place in (34b), because the tone 44 is by assumption unspecified. The default rules (33) apply to derive the surface phrasal pattern 44-535. The rule of Glottal Deletion is not formulated here as it is of marginal interest for our purpose.

The Changzhi facts can not be derived in a theory which represents contour tones as clusters of level tones (Woo

(1967), Hyman (1989)). Take the tone 24 as an example. In a cluster representation, the rising tone can be represented as LH. When the stem is suffixed, H is able to spread, but not L:

(35)	Lexical:	LH	(24)	
		xæ		"child"
	Suffixation:	LH	HLH	
		xæ	tə?	
	Spreading:	LH	HLH	
			+	
		xæ	tə?	
	Surface:	*xæ L tə? H		

The tone spreading facts of Changzhi indicates that contour tones must be represented as melodic units.

3.3.2 Register Assimilation

For register spreading data, we turn to Pingyao. Pingyao has five tones in citation form (all Pingyao data are taken from J.-Y. Hou (1980)):⁷

(36)	a. 13	ti	"animal's foot"
	b. 35	ti	"field"
	c. 53	ti	"top"
	d. <u>23</u>	xuΛ?	"hair"
	e. <u>54</u>	xuΛ?	"live"

7. For further evidence of register spreading, see 3.4.3.

The Representation of Tone

I assume that the two short tones are derivative, 23 from 13 and 54 from 53. So Pingyao has three underlying tones, which can be represented as follows:⁸

- (37) a. Low Rise 13:
- ```

 t
 / \
 r c
 | / \
 L l h

```
- b. High Rise 35:
- ```

      t
     / \
    r   c
    |   / \
    H  l  h
  
```
- c. High Fall 53:
- ```

 t
 / \
 r c
 | / \
 H h l

```

Bisyllabic phrases of verb-object or subject-verb constructions show tone sandhi effects. Relevant data are as follows:

8. The tones in (37) can be represented without underlying contour, as in (i):

- (i) a. 13: [L, l]      b. 35: [H, l]  
       c. 53: [H, h]

- (ii)
- ```

      c
      |
      |-----|
    [α slack] [-α slack]
  
```

The feature-inserting rule (ii) applies to the forms in (i), yielding the tones in (37). However, this move is of peripheral interest for our purpose. Since underlying contour is permissible, I will use the structures in (37) as the underlying representation of Pingyao tones.

The Representation of Tone

- (38) a. 13 13 > 13 13
- | | |
|-------------|------------------|
| t'ag u | "embezzle" |
| tɕ'əu tɕ'iE | "draw lottery" |
| tɕ'iE ɕig | "care" |
| kuag məŋ | "close the door" |
- b. 13 35 > 31-35
- | | |
|----------|------------------|
| tsəu ti | "rent land" |
| pu tag | "hatch an egg" |
| tei t'ag | "carry charcoal" |
| t'ag xua | "talk" |
- c. 13 53 > 35-423
- | | |
|------------|-----------------------|
| ts'uŋ mi | "grind rice" |
| tɕi ma | "ride a horse" |
| tsəŋ ts'ag | "increase production" |
| xei tsuə | "river flood" |
- d. 35-13 > 13-13
- | | |
|-----------|---------------------------|
| t'uə paŋ | "quit class" |
| xa kuei | "start cooking" |
| nia tɕ'ig | "play musical instrument" |
| yE ɕəŋ | "courtyard (is) deep" |
- e. 35-35 > 31-35
- | | |
|------------|-----------------------|
| pə ɕig | "upset" |
| ts'ɿ ts'ə | "cut vegetables" |
| ɕəu tɕɿ | "get wronged" |
| kuei tɕ'ag | "harvest celebration" |
- f. 35-53 > 35-423
- | | |
|----------|-----------------------|
| xa y | "rain" |
| tug xuei | "get angry" |
| ɕi niag | "hard of seeing" |
| sue ɿE | "greeting by gesture" |
- g. 53-13 > 53-13
- | | |
|----------|-------------------|
| tɕag iɔ | "stretch waist" |
| tsəu sei | "meteorite" |
| niE ɕəŋ | "distribute work" |
| k'əu tiE | "sweet-mouthed" |

The Representation of Tone

h. 53-35 > 53-35

suag tɕ'i	"breathe heavily"
ti s ₁	"useful"
tsue tɕia	"increase prices"
k'ag ti	"plow a field"

i. 53-53 > 35-423

ta tig	"take a nap"
mæ ϕi	"curry favor"
tɕ'i ts'o	"in heat"
ər nzuag	"ear soft"

The short tones 23 and 54 are omitted since they exhibit exactly the same sandhi behavior as their respective underlying tones. The bisyllabic tone patterns are summarized in (39), the vertical axis is the first tone of a bisyllabic phrase; the horizontal axis is the second tone:

(39)	I	II	III
	13	35	53
13	13-13	31-35	35-423
35	13-13	31-35	35-423
53	53-13	53-35	35-423

We make the following observations:

(40) Contour Dissimilation

- 13 and 35 become 31 before 35 (Column II)
 - 53 becomes 35 before another 53 (Column III)
- Register Assimilation
- 13 raises to 35 before 53 (Column III)
 - 35 lowers to 13 before 13 (Column I)
- Contour Formation
- 53 becomes 423 phrase-finally (Column III)

The Representation of Tone

The observations in (40) can be broken down into three types of sandhi effect. First, (40a,b) are cases of contour dissimilation; second, (40c,d) show register harmony within the bisyllabic phrase; this is the focal point of this section. Finally, (40e) is a contour-changing operation not conditioned by the preceding tone.

Consider first of all the effect of phrase-final high tones on the preceding tones. The rising tones 13 and 35 become 31 before 35, and the high falling tone 53 becomes 35 before 53 (cf. (40a,b)). In other words, the c node of the first tone metathesizes when followed by a high tone with the same c node. This is a case of contour dissimilation, which can be accounted for in terms of the metathesis rule in (41) (x,y are either [-slack] or [+slack]):

(41) Contour Metathesis

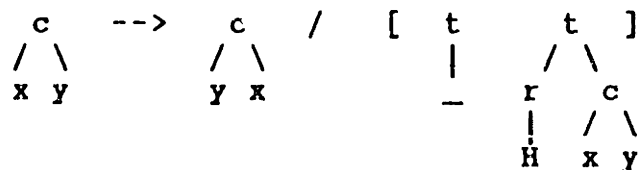

Note that the rising tone 35, which is high registered, becomes the low falling tone 31, rather than the expected high falling tone 53. This suggests that prior to the application of (41), the register of the high rising tone lowers. The lowering rule is given below:

The Representation of Tone

(42) Register Lowering:

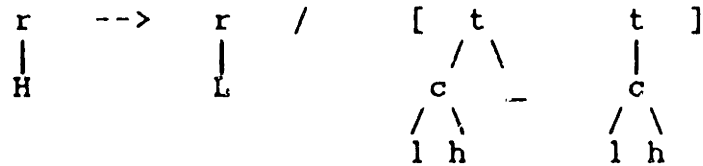

The rules of Contour Metathesis (41) and Register Lowering (42) derive the tone patterns when the phrase-final tone is 35. The sandhi facts which are of interest to us is the behavior of the two rising tones 13 and 35 when preceding 13 and 53. The underlying pattern 35-13 surfaces as 13-13, whereas 13-53 surfaces as 35-423. That is to say, a high tone lowers before a low tone, and a low tone raises before a high tone. Clearly this is a case of register spreading, which is accounted for by the rule in (43):

(43) Register Assimilation

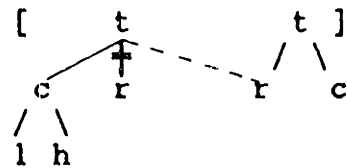

Notice that the phrase-initial c node must be specified as rising, because register spreading does not take place when the phrase-initial tone is falling. Register Assimilation (43) must order after Register Lowering (42) and Contour Metathesis (41). The effect of the register assimilation rule (43) is that the register of the phrase-initial rising tones harmonizes with the register of the

phrase-final tone.

Finally, we need a feature-inserting rule to derive 423 from 53 in phrase-final position. The rule is the Contour Formation in (44):

(44) Contour Formation:

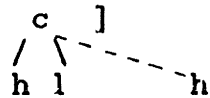

To illustrate how the rules work, consider the following derivations:

(45)

I	II	III
Underlying		
[L, lh]-[H, hl]	[H, lh]-[L, lh]	[H, lh]-[H, lh]
Register Lowering (42)		
--	--	[L, lh]-[H, lh]
Contour Metathesis (41)		
--	--	[L, hl]-[H, lh]
Register Assimilation (43)		
[H, lh]-[H, hl]	[L, lh]-[L, lh]	--
Contour Formation (44)		
[H, lh]-[H, hlh]	--	--
(35-423)	(13-13)	(31-35)

The Representation of Tone

<p>IV</p> <p>Underlying</p> <p>[H,hl]-[H,hl]</p> <p>Register Lowering (42)</p> <p>Contour Metathesis (41)</p> <p>[H,lh]-[H,hl]</p> <p>Register Assimilation (43)</p> <p>Contour Formation (44)</p> <p>[H,lh]-[H,hlh]</p> <p>(35-423)</p>	<p>V</p> <p>[H,lh]-[H,hl]</p> <p>not applicable</p> <p>--</p> <p>not applicable</p> <p>[H,lh]-[H,hlh]</p> <p>(35-423)</p>
--	---

The Pingyao data demonstrate that the register spreads independently of the contour. This supports the tonal geometry in which the register forms an independent node.

3.3.3 Contour Assimilation

In §3.2, we discussed the tone inventory of Weining Miao, and showed that contour must be represented underlyingly as a sequence of the feature [slack]. The tone inventory of Weining Miao does not provide empirical motivation for the existence of the c node. Contour can be represented either as (46a) or as (46b):

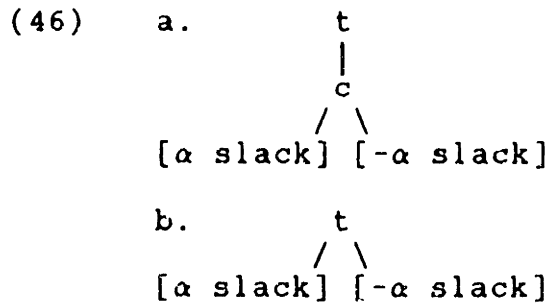

The two structures make different predictions which can be empirically tested. By virtue of the fact that the c node dominates the sequence of [slack], (46a) predicts the existence of sandhi processes which refer to the c node as a unit. Assimilatory spreading of the c node is one such process that is predicted to occur by a theory which adopts the structure (46a). The prediction is not made by a theory which makes use of the structure (46b). To argue that the sequence of [slack] forms the c node in (46a), we need to demonstrate that they behave phonologically as a unit. I now proceed to present the empirical data that would substantiate the claim that contour assimilates.

3.3.3.1 Zhenjiang

One dialect which exhibits the phenomenon of contour spreading is Zhenjiang, a Mandarin dialect spoken in the province of Jiangsu. Zhenjiang has five tones in citation form, as shown in (47) (all Zhenjiang data are taken from H.-N. Zhang (1985)):

The Representation of Tone

(47) Tonal Inventory of Zhenjiang

a. 42	ts ₁	"know"	mu	"monster"
b. 31	tsh ₁	"resign"	mi	"rice"
c. 35	ts ₁	"son"	mi	"riddle"
d. 55	ts ₁	"self"	mī	"face"
e. 5	tse?	"occupation"	mi?	"destroy"

As can be seen from the data, the short tone 5 is realized in syllables ending in the glottal stop. The bisyllabic sandhi effects in Zhenjiang are summarized in the table in (48), where phrase-initial tones are in the first column and the phrase-final tones are in the first row:

(48)	I	II	III	IV
	42	31	35	55
42	35-42	35-31	33-35	33-55
31	35-42	35-31	22-35	22-55
35	35-42	35-31	35-35	22-55
55	55-42	55-31	55-35	55-55

The short tone 5 has the same sandhi behavior as 55. We will focus on the tone patterns of phrases ending in the high even tone 55 (Column IV in (48)). As can be observed, the two falling tones, 42 and 31, and the rising tone 35, become even when followed by the high even tone 55. Relevant data are given below:

The Representation of Tone

(49) a. 42-55/5 > 33-55/5

səŋ piŋ	"fall ill"
tshə tsoŋ	"operate"
ɕioŋ ti	"brother"
s ₁ lu	"train of thought"
fog jic	"maple leaf"
sɛn jy?	"March"
ɕi ja?	"Western medicine"
tshoŋ tso?	"sufficient"

b. 31-55/5 > 22-55/5

tɕhi si	"revelation"
ɰən nɛ	"endure"
lɛn to	"lazy"
lən tɕhi	"cold air"
tɕhiŋ khə?	"invite guests"
tu pa?	"gamble"
huei mi?	"destroy"
ɕio suo?	"novel"

c. 35-55/5 > 22-55/5

ɕi huei	"virtuous"
ɰən miŋ	"human life"
phūn wən	"cross-examine"
ji li	"severe"
thūn tɕi?	"unite"
huəŋ sə?	"pornographic"
tɕhi tɕia?	"bind feet"
tɕhŷ li?	"power"

When 55 or 5 precedes 55 or 5, both tones surface:

(50) a. 55-55/5 > 55-55/5

ts ₁ ɛ	"self love"
ts ₁ sa?	"suicide"

b. 5-55/5 > 5-55/5

tseŋ-wei	"position"
tseŋ-ji?	"occupation"

The Representation of Tone

From the above data we observe that the non-even tones become even before the high even tone 55. This is a case of contour assimilation.

I assume that the tones in Zhenjiang have the structures in (51):

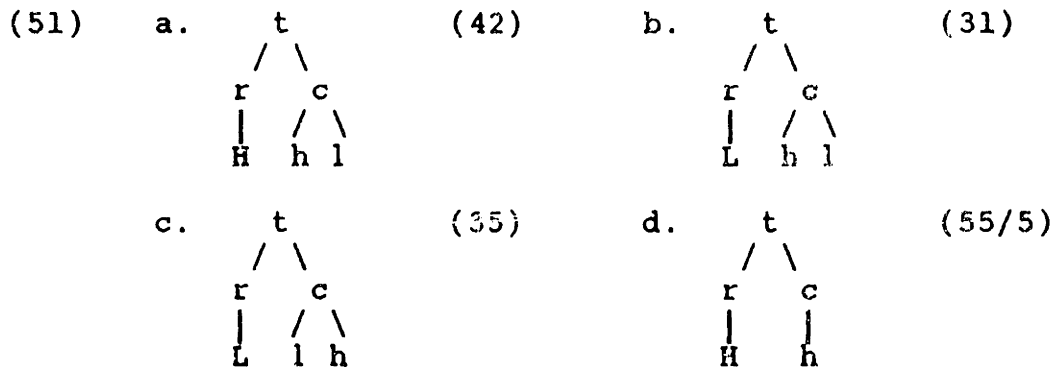

The reason to treat the rising tone 35 as a L-registered tone is due to its sandhi behavior: it surfaces as the even tone 22 when followed by the high even tone 55/5. The contour assimilation process can be captured by the spreading rule in (52):⁹

9. H.-N. Zhang (1985:195-6) gives three rules to derive the bisyllabic sandhi patterns in (48). Zhang's rules are formulated in terms of notions of falling, rising and low. The rules are as follows:

- (i)
- a. Falling --> Rising / _ Falling
 - b. Falling --> Even / elsewhere
 - c. Rising --> Even / _ Even

The spreading rule in (52) does not cover the same range of facts as any of the rules individually. For instance, the spreading rule does not account for the fact that the two falling tones surface as even before the rising tone as well. This fact is accomplished by Zhang's rule (ib).

The Representation of Tone

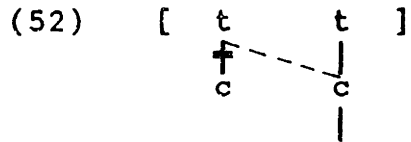

The rule spreads a nonbranching c node, indicated by a single branch underneath the node, to the preceding tone, delinking the latter's original c node. Since there is only one underlying even tone (51d), we need not mention the register or specify the contour in the rule. (53) are the derivations of the patterns in Column IV of (48) involving the rising and falling tones:

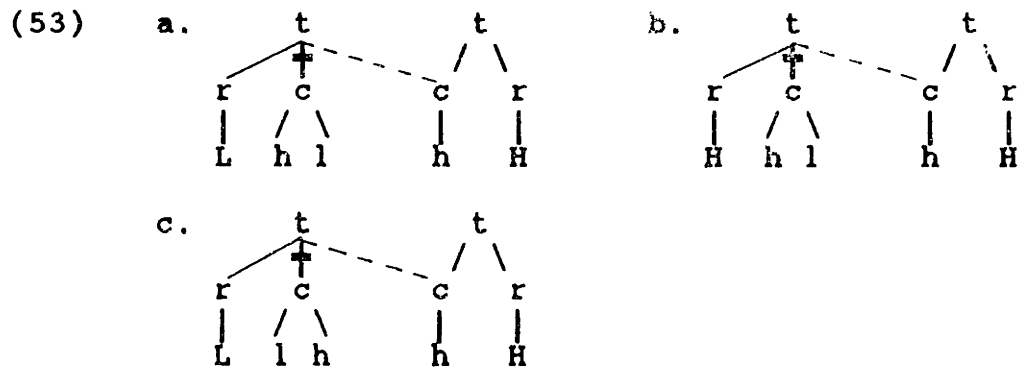

Notice that the high falling tone 42 surfaces as 33 and the low falling tone 31 surfaces as 22. This difference can be attributed to the difference in their registers: in (53a) the register of the first tone is L ([-stiff]); in (53b) it is H ([+stiff]). Contour spreading does not affect the registers at all.

Contour spreading creates the two structures shown in (54), (54a) from (53a,c) and (54b) from (53b):

The Representation of Tone

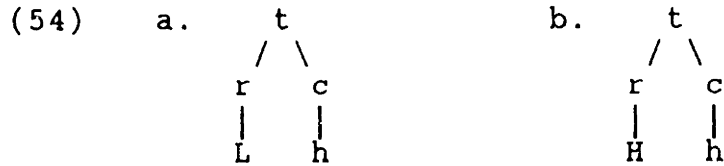

(54b) is not accounted for by (52): as an underlying tone it surfaces as 55 in both citation and sandhi forms; as a derived tone it surfaces as 33 (cf. (48)). Given the structures of the tones in (51), particularly the structure for the high even tone 55 in (51d), after Contour Spreading the bisyllabic structure would be formally indistinguishable from the structure with two underlying high even tones:

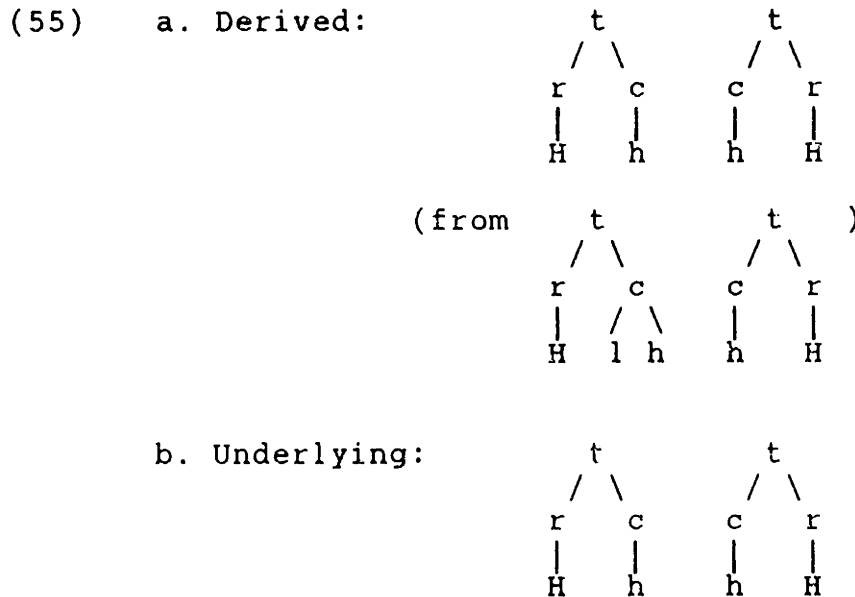

Within the proposed model of tone, there are two ways to lower an even-contoured tone: by lowering the register from [+stiff] to [-stiff], or by changing the c node specification from [-slack] to [+slack]. As noted earlier,

The Representation of Tone

the difference between 22 and 33 is attributable to the difference in their registers. Therefore, we need to keep the registers of the two tones in (54) distinct in derived environment. Even if we do lower the register of (54b) from [+stiff] (H) to [-stiff] (L), we will not be able to distinguish the two structures in (54).

Alternatively, we can formulate a rule which changes the c node specification, as in (56):

$$(56) \quad \begin{array}{c} c \\ | \\ h \end{array} \rightarrow \begin{array}{c} c \\ | \\ l \end{array} / \begin{array}{c} [\quad t \\ / \quad \backslash \\ r \quad \quad - \\ | \\ H \end{array}$$

This rule has the effect of lowering the pitch level of an even-contoured tone in phrase-initial position. However, it will apply incorrectly to both the derived string and the underlying string, which meets its structural condition. Suppose that the register of the high even tone 55 is unspecified underlyingly, as in (57a), and the H value is supplied by the default rule (57b):

$$(57) \quad \begin{array}{l} \text{a.} \quad \begin{array}{c} t \\ / \quad \backslash \\ r \quad \quad c \\ \quad \quad | \\ \quad \quad h \end{array} \quad \text{b.} \quad [\quad] \rightarrow [+stiff] \end{array}$$

If so, the two structures in (55) are actually the ones in (58), with unspecified r nodes:

The Representation of Tone

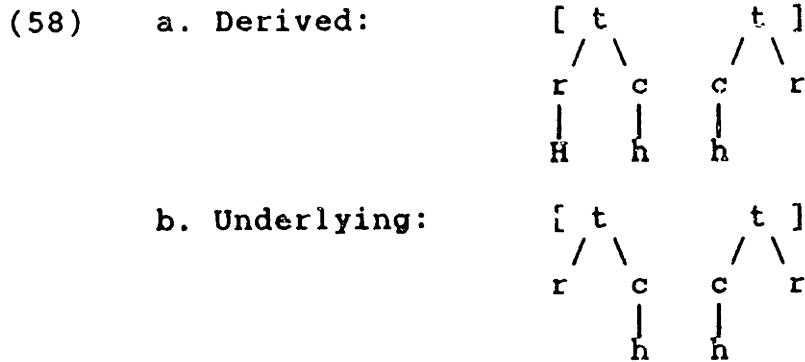

The rule (56) applies to the string in (58a), but not (58b), since the rule requires a H register as part of its structural description. Obviously the spreading rule applies before the default rule. The derivation of the patterns in Column IV of (48) follows:

(59) Underlying Representation:



Contour Spreading (52)/Conflation



Pitch Lowering (56)

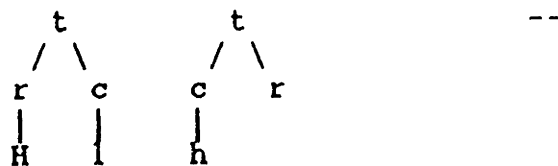

The Representation of Tone

Default Rule (57)

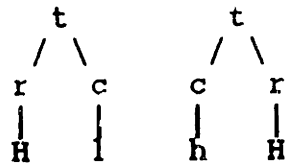

(33-55)

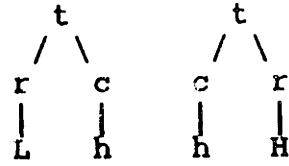

(22-55)

Underlying Representation:

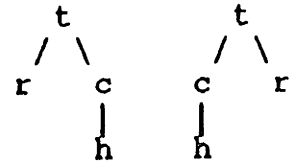
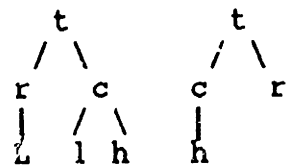

Contour Spreading (52)/Conflation

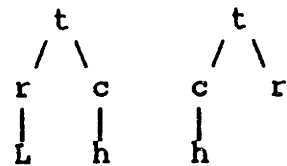

Lowering (56)

not applicable

Default Rule (57)

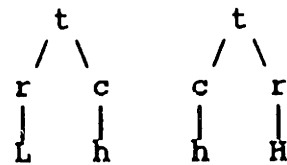

(22-55)

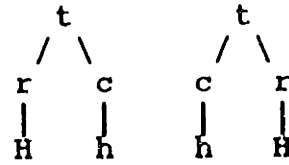

(55-55)

The analysis of the Zhenjiang data demonstrates the existence of the c node in the geometry of tone.

3.3.3.2 Wenzhou

Wenzhou is a Wu dialect spoken in the coastal city of Wenzhou, Jiangsu Province. Like other Wu dialects, it still retains voicing as a distinctive feature of its consonantal phonemes (see Appendix), and its tonal inventory reflects the influence of the voicing qualities of syllable-initial segments. It has eight tones in citation form, shown in (60) (unless otherwise indicated, all Wenzhou data are taken from Zhengzhang (1964b)):¹⁰

(60)	a. 44	b. <u>45</u>	c. 42	d. <u>323</u>
	A. 31	B. <u>34</u>	C. 22	D. <u>212</u>

The underlined tones are the so-called "tense-throat tones," and relatively short (Zhengzhang (1964a)). 323 and 212 are derived historically from syllables ending in stop obstruents. In modern Wenzhou such syllable types no longer exist, so the tones 323 and 212 manifest themselves as being tense and relatively short. The tones (60a-d) are used in voiceless-initial syllables, and those in (60A-D) are used in voiced-initial syllables. Bisyllabic phrases surface in one of the eight phrasal tone melodies (see Appendix for the complete table of bisyllabic tone patterns), of which we

10. The same sandhi phenomenon, slightly revised, can be found in Zhengzhang (1980). In both articles Zhengzhang discusses two varieties of the Wenzhou dialect, those of the city proper and a suburban area called Yongzhong. I discuss the variety spoken in the city proper.

The Representation of Tone

will consider Patterns F and F'. These two patterns have the following tonal shapes:

(61)	Tone Melodies	Source Tones
F.	42-21	(60b,B,C)-(60A) (60b,B,c,C)-(60c)
F'.	21-42	(60d,D)-(60c)

The patterns are exemplified in (62) and (63), respectively:¹¹

(62)	a. 45-31	kou liang hai yuan	"food ration" "seaman"
	b. 34-31	lao po dong yuan	"wife" "mobilize"
	c. 42-31	zheng ming jing tai	"prove" "mirror table"
	d. 22-31	wai po di qiu	"grandmother" "Earth"
	e. 45-42	hao huo guang po	"good product" "broadcast"
	f. 34-42	yan jing niu kou	"eye glasses" "button"
	g. 42-42	chang pian fen dou	"record" "struggle"
	h. 22-42	yun qi jiu deng	"luck" "old bench"

11. A note on transcription is in order. Zhengzhang uses Chinese characters as examples. So the transcription of data, except tones, is in Pinyin, based on Mandarin pronunciation.

The Representation of Tone

(63)	a.	<u>323</u> -42	hei bu zhe kou	"black cloth" "discount"
	b.	<u>212</u> -42	bai bu yao pian	"white cloth" "tablet"

One important observation we can make with respect to the tone patterns is that the second source tone is either 31 or 42, namely falling in contour. The two tones which comprise Patterns F and F' are both falling in contour (we will ignore the phonetic difference between 31 and 21, which do not occur in the same environment). According to Zhengzhang, in bisyllabic phrases, the stress falls on the first syllable, except when the first source tone is either 323 or 212, in which case the stress falls on the second syllable. In Pattern F, therefore, the first syllable is stressed; and in Pattern F', the second syllable is stressed. Suppose that in bisyllabic phrases stress is assigned to the first syllable if the syllable carries tones other than 323 or 212 (historically such syllables end in stop obstruents); otherwise stress is assigned to the second syllable. We can then make the following observation:

- (64) In bisyllabic phrases, the stressed syllable has the high falling tone 42; the unstressed syllable has the low falling tone 21.

To derive the Patterns F and F', let's suppose that the two falling tones 42 and 31 (or 21) have the following structures:

The Representation of Tone

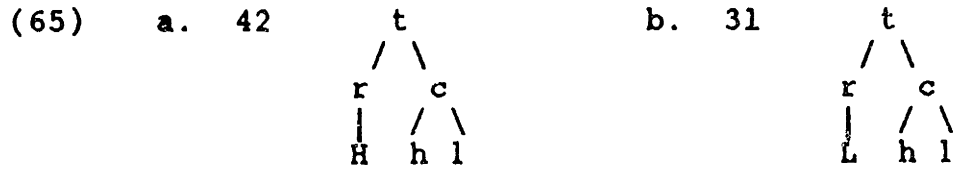

The two patterns can be derived in four steps:

- (66) a. assign stress
- b. delete the register and contour of the source tones except the last tone;
- c. spread the c node of the last tone
- d. assign H to the tone in the stressed syllable and L to the tone in the unstressed syllable.

The mechanism is illustrated by the derivation in (67):

- (67) a. Assign Stress (indicated by *)

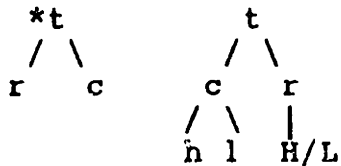

Delete Register and Contour

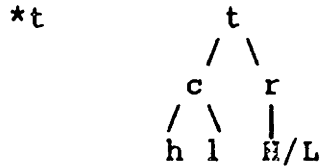

Spread Contour

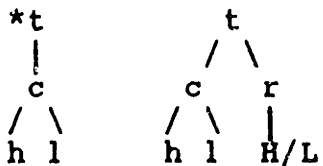

The Representation of Tone

Assign Register

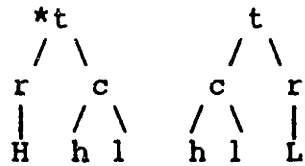

b. Assign Stress (indicated by *)

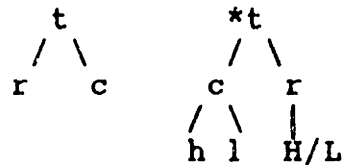

Delete Register and Contour

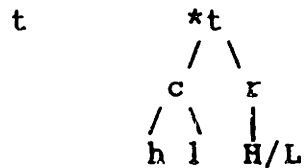

Spread Contour

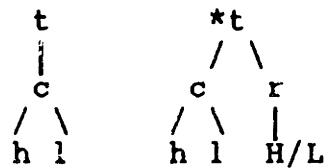

Assign Register

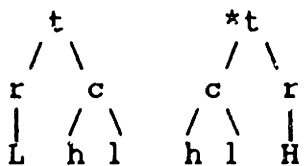

(67a) is the derivation of Pattern F, and (67b) is the derivation of Pattern F'. The difference between the two patterns is stress. If the first syllable carries the tones 323 or 212, stress will be assigned to the second tone, the bisyllabic phrase will then surface as 21-42, which is the

Pattern F'. It is assumed that the rules of contour spreading and register assignment, which are not formulated, apply to the bisyllabic patterns enumerated in (61). The exceptional cases are tonal combinations of (60c)-(60A) and (60d,D)-(60A); the former is expected to surface as Pattern F, and the latter as Pattern F'; but this expectation is not borne out. They all surface as 22-2 (Pattern C) (cf. Appendix).

The analysis of Patterns F and F' relies crucially on contour spreading; which supports the postulation of the c node as an integral part of the geometry of tone. The tone pattern of tri-syllabic phrases based on the bisyllabic Pattern F furnishes further evidence for contour spreading. Tri-syllabic phrasal tone patterns depend entirely on the last two syllables. According to Zhengzhang (1980), tri-syllabic phrases whose last two syllables would surface as Pattern F have this property: if the stress is on the first syllable, the pattern is 42-21-21;¹² if it is on the second syllable, the pattern is 21-42-21. If the first syllable carries the tone 323 or 212, which is stressless, the pattern is 21-42-21. Thus, the analysis of the sandhi data in terms of contour spreading is supported by the tri-

12. In Zhengzhang (1980), Pattern F is given as 42-1, where 1 is a low neutral tone. He explains that in slow speech, Pattern 42-1 surfaces as 42-21. I stay with the slow speech version.

syllabic tone sandhi facts. The Wenzhou data provide empirical support for the tone model which incorporates the c node.

3.3.4 Feature Assimilation

Gao'an furnishes data which show that the terminal nodes which comprise the c node also exhibit assimilatory sandhi behavior. Gao'an has seven tones in citation form (Yan (1981)):¹³

- | | | |
|------|--------|----------------------------|
| (68) | a. 55: | ka "add"; siu "repair" |
| | A. 24: | siu "rest" |
| | b. 42: | hou "beg" |
| | c. 33: | p'i "match"; su "four" |
| | C. 11: | p'ei "double"; t'i "earth" |
| | d. 3: | tsok "table" |
| | D. 1: | hok "study"; siak "stone" |

(68a,A), (68c,C) and (68d,D) are alternating pairs (pairs which are conditioned by the syllable-initial consonants) in Classical Chinese; (68a,c,d) were used with voiceless-initial syllables and (68A,C,D) with voiced-initial syllables. Modern Gao'an, however, does not have voiced obstruents. As can be seen in the examples, siu 55 "repair" vs. siu 24 "rest" and p'i 33 "match" vs. p'ei 11 "double", the tones (68a) through (68C) are distinctive. (68d,D) are the two short tones realized on syllables ending in /p t k/.

13. In addition to the seven tones in (68), there is also the so-called neutral tone, which is left out here.

The Representation of Tone

They are non-distinctive, derivable from (68c,C). Thus, Gao'an has an inventory of five underlying tones: three even tones (high, mid, low), one low falling tone and one low rising tone. The underlying tones of Gao'an may have the structures in (69):

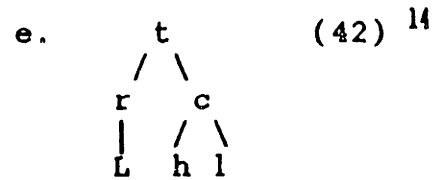
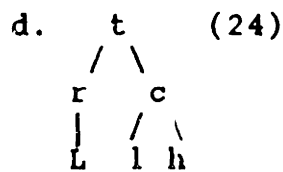
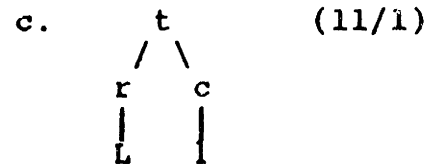
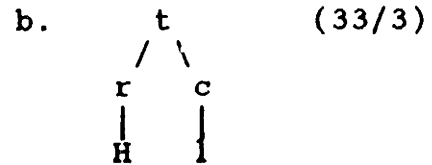
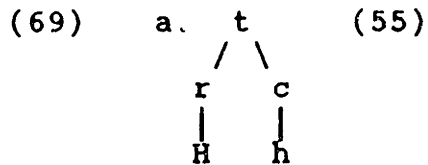

In bisyllabic phrases, the high even tone 55 becomes the high falling tone 53 when preceding the mid even tone 33 and the low even tone 11, and their short tone counterparts. Relevant data are given in (70) (Yan (1981:105)):¹⁵

14. The reason to treat 42 as an underlying low register tone has to do with the existence of 53, which is derived from the underlying high even tone 55. 53 does not exist underlyingly, or in citation form. This move underscores the relative nature of tonal pitch. For some systems, 42 would be considered as high falling. But in the presence of a 53 and the absence of a 31, I think it is justified to consider 42 as low falling underlyingly, although on the surface it is pretty high in pitch.

15. 55 becomes 53 before the neutral tone as well.

The Representation of Tone

- (70) a. 55-33 > 53-33
- | | |
|----------|-----------------|
| ɕieu han | "make charcoal" |
| sog tɕi | "bi-seasonal" |
| siu p'i | "repair" |
| sam su | "three-four" |
- b. 55-11 > 53-11
- | | |
|-----------|--------------------|
| ka p'ei | "double" |
| t'ien t'i | "heaven and earth" |
| kuŋ ɕia | "commune" |
| tɕi han | "egg" |
- c. 55-3 > 53-3
- | | |
|-----------|----------------|
| ka k'uet | "broaden" |
| tug pət | "northeast" |
| fog tsok | "square table" |
| sag t'iet | "pig iron" |
- d. 55-1 > 53-1
- | | |
|-------------|---------------------|
| tɕiuŋ iok | "Chinese medicine" |
| k'ei hok | "opening of school" |
| tɕiaŋ yot | "first month" |
| ts'iaŋ ɕiak | "stone" |

No other bisyllabic phrases exhibit sandhi effects. The mid even tone 33/3 and the low even tone 11/1 form a natural class which conditions the 55>53 sandhi change, stated informally in (71):

- (71) 55 --> 53 / _ 33, 11, 3, 1

Formally the two even tones 33 and 11 share the same c node, namely [+slack], but their register specification is different: 33 is [+stiff] (cf. (69b)), and 11 is [-stiff] (cf. (69c)). The registers of the tones 33/3 and 11/1 do not figure in conditioning the 53>55 sandhi. A necessary

The Representation of Tone

condition is the contour of even, that is, the c node of the conditioning tone must not branch. The high falling tone 53 is created by spreading the l node dominated by the c node. The rule is formulated in (72):

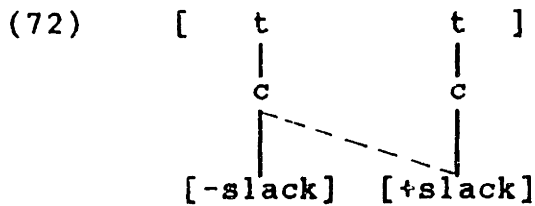

Condition: the c nodes do not branch

The derivation of the tone pattern in (70a) is as follows:

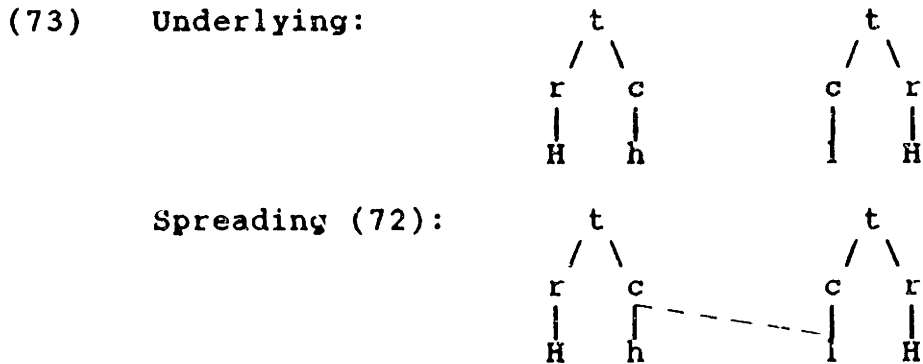

It is not necessary to state the register of the target tone (the phrase-initial tone) in the structural description of the spreading rule, since 55 (cf. (69a)) is the only tone that has a nonbranching c node dominating [-slack]. The register of the spreading tone can not be mentioned, since the mid even tone and the low even tone are assumed to have different specification for the register feature [stiff]

The Representation of Tone

(cf. (69b,c)). The condition that the c node of the second tone in the statement of the rule (72) be non-branching becomes necessary because it prevents the [+slack] branch of the rising tone 24 from spreading to the first tone; similarly, the c node of the first tone must be specified as nonbranching to prevent the spreading rule from applying to the rising tone 24, which would produce a convex contour. The two illicit derivations are illustrated below:

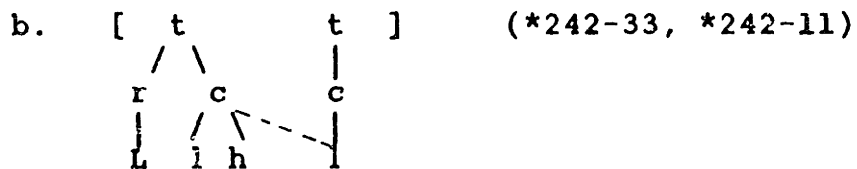
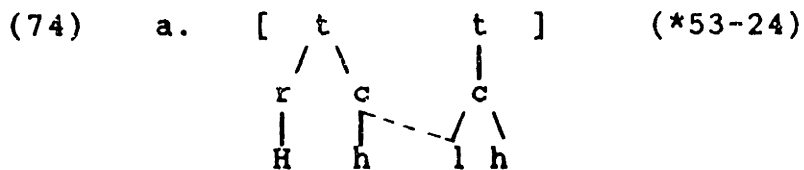

Note that the spreading rule (72) not only refers to the terminal nodes of [slack], but also to the formal structure of the c node. This property provides further support for the existence of the c node.

The preceding analysis of the Gao'an data depends crucially on the underlying structures we assumed for the even tones 55, 33/3 and 11/1. An alternative analysis is possible if we assume the following structures for the even tones:

The Representation of Tone

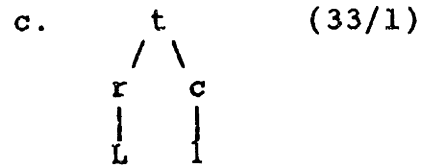
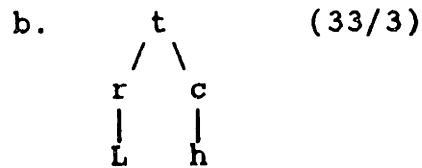
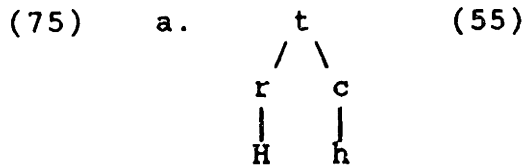

Thus, the mid and low even tones 33/3 and 11/1 belong to the same class by virtue of their register specification, which is [-slack]. The 55>53 sandhi can be seen as a process of contour dissimilation -- the even contour of the high even tone 55 dissimilates when followed by the two [-stiff] even tones. The dissimilation process can be captured by a feature-inserting rule stated below:

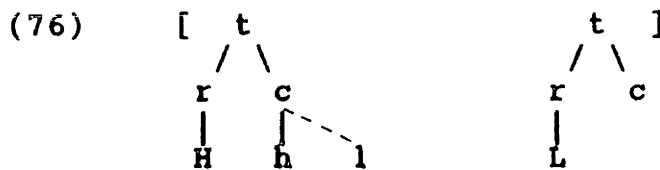

Condition: c nodes do not branch

(76) turns the even contour into the falling contour before another even contoured tone. What is significant is that this analysis also refers to the terminal feature of [slack], in addition to the formal structure of the c node that must be mentioned in the statement of the rule.

The Representation of Tone

3.4 Contours and Other Matters

3.4.1 Distributional Properties of Tones

3.4.1.1 The Distribution of Even Tones

By definition, an even tone is one which maintains the same pitch height throughout the duration of the tone bearing unit. To facilitate discussion, the structures of four even tones are given below:

(77) High Register Even Tones:



Low Register Even Tones:



An inventory with four even tones, though rare, is nonetheless attested. Liuyang, a dialect spoken in the Hunan Province, has a tonal inventory with five tones, four of which are even (J.-Q. Xia (1983)):

(78) Tonal Inventory of Liuyang

- a. 33: pei "cup"; ko "brother"
- A. 55: p'in "poor"
- b. 24: xau "good"
- c. 11: t'i "big"
- d. 44: t'i "wash"

Diachronically, (78a) and (78A) are derived from syllables with voiceless and voiced initials, respectively. Modern Liuyang, however, has lost voiced obstruents. Hence the two tones in (78a,A) are contrastive, as both are realized on voiceless initial syllables. Our model provides distinct formal representations for each of the four even tones in (78).

Most dialects which have been reported in the literature have in their tonal inventories no more than two even tones, either at the underlying or surface levels. When we discuss the distribution of even-contoured tones, a distinction must be made between those tonal systems which exhibit register alternation conditioned by the voicing qualities of the syllable-initial consonants and those which do not. Cross-dialectally, a tone system with register alternation involving the even contour is likely to contain the pair 44/22 (55/33) or 33/11. (Henceforth I will use "alternating tones" or "alternating pairs" to refer to tones such as 44 and 22, which are in complementary distribution with respect to the voicing qualities of the syllable-initial segments). This observation is significant because

The Representation of Tone

it suggests that, at least in the unmarked case, a pair of even tones alternates on the register node, leaving the c node intact. The representation of the even tones in (77) allows two ways to lower the pitch level of a tone: by lowering the register from H to L, or by changing the terminal node of a nonbranching c node from h to l. Given that both tonal register and consonantal voicing is specified by the feature [stiff], the alternation between high and low even tones must involve a register changing phonological rule. Note that alternating falling or rising tones necessarily differ in their registers, necessarily because the proposed theory has a single representation for the falling and rising contours. Despite the fact that our theory generates four even tones, with respect to register-sensitive rules the primary contrast among even tones is H versus L registers. In this regard the 44/22 alternation in Songjiang (cf. (10)) is typical in that the difference between the two even tones is the register. Both have the same specification for the c node, as shown in (79):

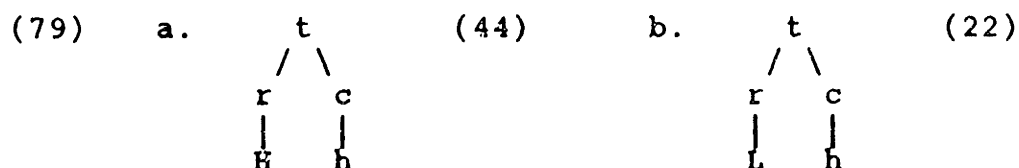

Some dialects have two alternating even tones which differ in the c node from those in (79). Shaoxin is such a

dialect. It has eight surface tones, as in (80) (Yuan et al (1960:80)):¹⁶

(80)	a. 51	b. 335	c. 33	d. <u>45</u>
	A. 231	B. 113	C. 11	D. <u>12</u>

Shaoxin still maintains voicing as a distinctive feature among its obstruents. The low tones in (80A-D) are in complementary distribution with the high tones in (80a-d). Consider now the structures of the two even tones 33 and 11 in (81):

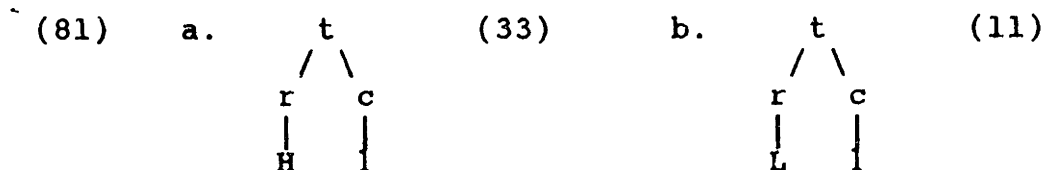

Like the 44/22 pair in Songjiang, 33 and 11 alternate only in the register. They have the same specification for the c node.

In the two dialects Songjiang and Shaoxin, the two alternating even tones are specified either as [-slack] (h) or as [+slack] (l). If the c node is [-slack], both the high tone and the low tone are realized in the upper end of their

16. Shaoxin has one of the rare tonal inventories with the surface falling tone 51 in citation form. It, however, does not alternate with 31. See §3.4.1.2 for discussion on the distributional properties of contour (fall or rise) tones. Underlyingly 51 may be represented in the same way 53 is represented. There is no formalism within the proposed theory to distinguish between 53 and 51. I take it as a phonetic detail that has little phonological relevance.

The Representation of Tone

respective registers, hence the pair 44/22 (similarly the pair 55/33 in some dialects). If, on the other hand, the contour node is [+slack], both the high and low tones will be realized in the lower end of their respective registers, yielding 33/11, as in Shaoxin. To my knowledge, no tone system with register alternation contains an alternating pair 55 and 11, which are at the two extremes of the pitch scale, and would require structures in (82):

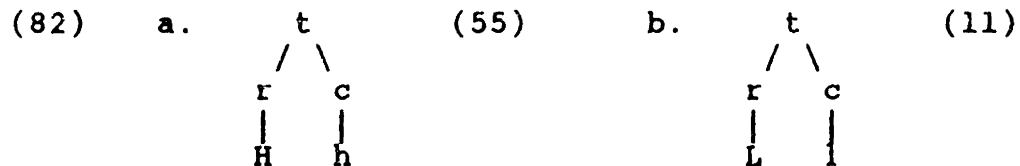

The fact that 55 (82a) and 11 (82b) as alternating tones do not exist lends empirical support for the analysis which treats register lowering as a phonological process involving a feature-changing rule. Although it is theoretically possible to have the two tones in (82) as alternating tones, the formal relationship between these two tones involves both the register and the contour. Therefore the formal statement which captures the relationship would be more complex -- it would consist of one phonological rule to account for the register difference, and one rule to account for the contour difference. In dialects which do not exhibit register alternation, there is no restriction on the occurrence of even tones. We have seen Liuyang with four

The Representation of Tone

even tones (cf. (78)), including 55 and 11, all of which are underlying. Other dialects which contain 55 and 11 in their tonal inventories include Taiyuan and Daning, two Mandarin dialects spoken in the province of Shaanxi (Hou et al (1986:90)):

(83) Taiyuan Tonal Inventory:

a. 11 b. 53 c. 55 d. 2 e. 43

Daning Tonal Inventory:

a. 35 b. 11 c. 55 d. 2

2 and 43 are short tones. In the unmarked case, the two tones 55 and 11 occur only as non-alternating tones. Like alternating falling or rising tones, alternating even tones share the same c node specification.

3.4.1.2 The Distribution of Contour Tones

The proposed tonal geometry places a constraint on the possibilities of falling or rising contours. Since the r node determines the register within which the c node specifies the tonal contour over the duration of the tone bearing unit, we expect contours to form within a single register. Cross-dialectal evidence meets our theoretical expectation. Although it is possible for a language to have 51 and 31 or 15 and 13 as contrastive tones in its tonal inventory, it is nonetheless a statistically significant

The Representation of Tone

fact that the tones 51 and 31 (or 15 and 13) rarely co-occur in the same tone language. Typically, in dialects which have two contrastive falling tones, we will find 53 (or 42) in opposition with 31 (or 21). Similarly for the rising tones. Given sufficient degree of idealization, the high variant is in the yin register, and the low variant is in the yang register. A survey of some 120 dialects of Chinese reveals the following distribution:

(84)	Tones	Number of Dialects
Fall:	53 and 31	14
	51 and 31	1
	51 and 53	0
Rise:	35 and 13	5
	15 and 13	0
	15 and 35	0

In fact, the tone 15 does not occur in any of the dialects surveyed, either by itself or together with 13 or 35. The distributional pattern is statistically significant concerning tonal contours. In the great majority of cases a tone system avoids two tones with the same start or end points but different pitch differential. Thus, the pairs 51/53, 15/13 and 15/35 do not occur at all; and the pair 51/31 is rare. This distribution of contour tones can be illustrated by the diagrams in (85):

(85) a. Unmarked Pairs:

53 vs. 31

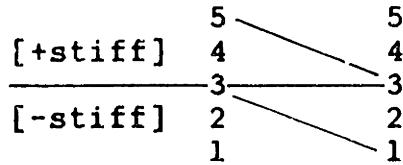

35 vs. 13

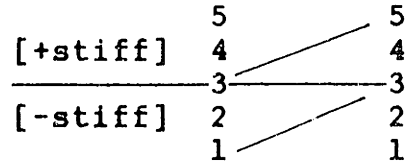

b. Marked or Non-occurring Pairs:

51 vs. 31

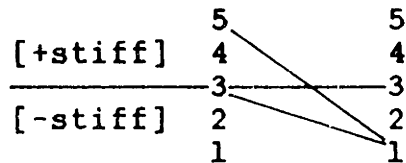

15 vs. 13

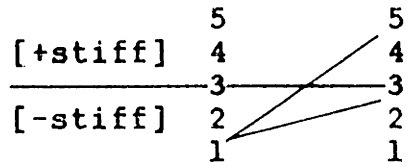

Given the proposed tone geometry, we expect an upper limit on how contours may be created -- in the unmarked case, a high falling contour is not likely to fall from the highest pitch point all the way to the lowest. The distributional evidence meets the theoretical expectation.¹⁷

17. The distributional properties of the contour tones also follow from Yip's (1980) theory, since our tone features are functionally equivalent to Yip's [upper] and [raised].

3.4.2 Convex and Concave

In §3.1, we made the stipulation (6),

- (6) Underlyingly, the contour node may have at most two branches.

which entails the proposition (7):

- (7) Concave/convex contours are surface phenomena

In other words, the structures of the underlying c node is either nonbranching or binary branching:

- (86) a.
$$\begin{array}{c} c \\ | \end{array}$$
 b.
$$\begin{array}{c} c \\ / \ \backslash \end{array}$$

We now present empirical evidence which confirms the proposition (7). Formally, we represent the concave and convex contours as in (87):

- (87) a. Concave:
$$\begin{array}{c} c \\ / \ | \ \backslash \\ h \ l \ h \end{array}$$
- b. Convex:
$$\begin{array}{c} c \\ / \ | \ \backslash \\ l \ h \ l \end{array}$$

In terms of cross-dialectal distribution, complex tones exist in citation form, and to a lesser extent, in sandhi form as well. There are three cases we need to consider: tone systems in which complex tones appear only in citation form; those in which they exist only in sandhi form; and

those in which they exist in both citation and sandhi forms. The reduction of surface complex contours to simpler contours at the underlying level depends on two considerations: the tonal inventory of the language in question, and the sandhi behavior of the complex tones. Changzhi and Xining, both Mandarin dialects, furnish data which show that, upon proper analysis of their tonal inventories and the sandhi behavior of the tones, the complex contours are derivable from simpler contours.

3.4.2.1 Changzhi

First, consider the dialect of Changzhi. Changzhi has a tonal inventory of five tones, plus a short tone, in citation form (J.-Y. Hou (1983)):¹⁸

(29)	a. 213	ts'əu "suck"	paŋ "spotted"
	A. 24	ts'əu "thick"	p'ag "plate"
	b. 535	ts'o "weed"	pu "cloth"
	c. 44	ts'əu "stinky"	paŋ "half"
	C. 53	tsu "column"	paŋ "stick"
	d. <u>54</u>	tsəʔ "choose"	paʔ "pull"

Changzhi does not have voiced obstruents, and the pairs (29a,A) and (29c,C) are distinctive, as can be seen from the onset obstruents of the data given. Disregarding the short tone 54, we have one even tone 44, one falling tone 53 and

18. We saw Changzhi in §3.3.1.2, where I analyzed the tone spreading phenomenon induced by the nominal and adjectival suffixes.

The Representation of Tone

one rising tone 24. If we treat them as underlying tones, they would have the structures in (88):

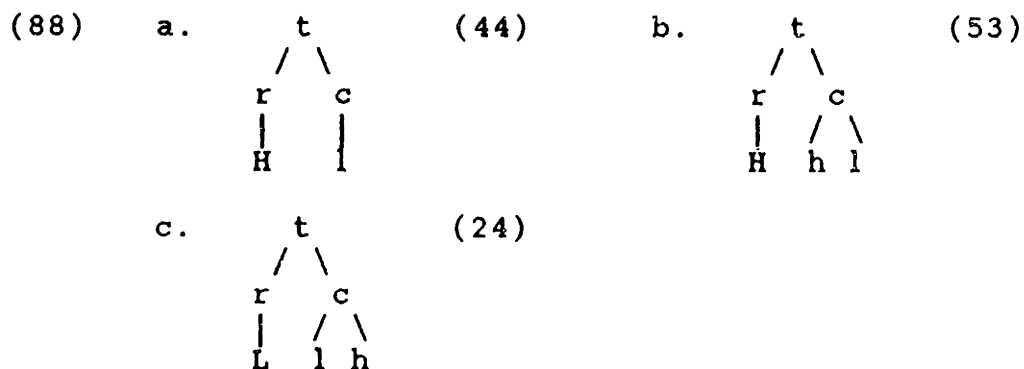

Given these tones, it is theoretically impossible to reduce the complex tones 213 and 535 to underlying falling or rising tones, as there would be three underlying falling or rising tones, inexpressible within the proposed theory, which is capable of representing only two tones each for the falling and rising contours. But if we assume that the tones in (88) are all underlyingly even, we can consider the surface concave tones 213 and 535 as being derived from underlyingly falling tones. The underlying tonal inventory of Changzhi is given below:

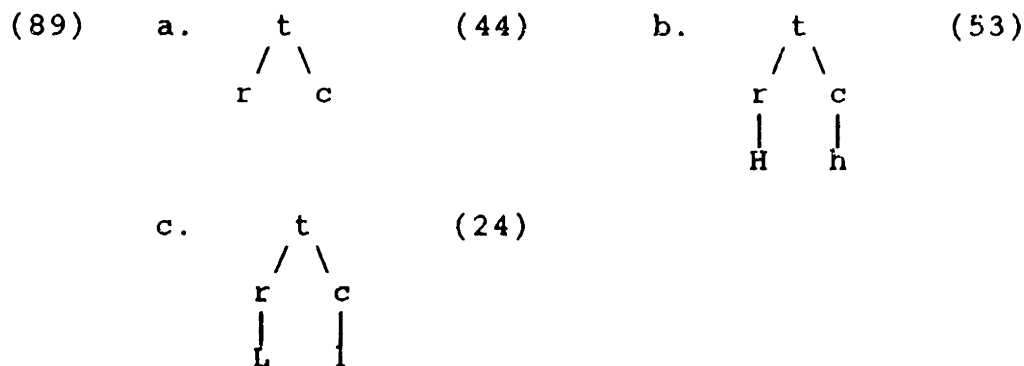

The Representation of Tone

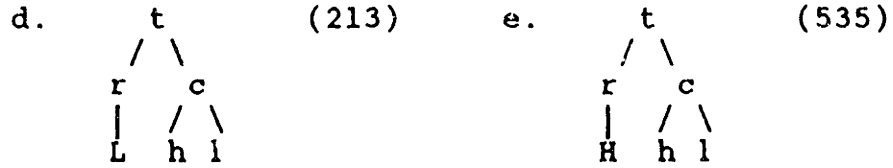

In §3.3.1.2, I argued that the tone 44 is underlyingly unspecified as in (89a), and two default rules supply the register and contour values. The default rules are repeated below as (90):

- (90) a. [] --> [-stiff]
 b. [] --> [-slack]

The reason to consider 44 as a L-registered tone is that in verbal reduplication, 44 surfaces as low falling 31 in phrase-initial position. To derive the citation tones from the underlying structures in (89), I propose the feature-inserting rule (91):

(91) Contour Formation

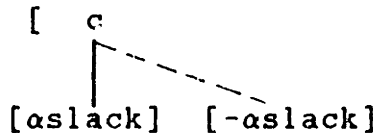

The rule applies to tones in citation form, and to the initial tones in reduplicated verbal phrases, as we will see shortly. (91) inserts [+slack] to the right of [-slack], and [-slack] to the right of [+slack]. It maps the underlying structures in (89) to the ones in (92):

The Representation of Tone

- (92) a.
$$\begin{array}{c} t \\ / \quad \backslash \\ r \quad c \\ | \quad | \\ H \quad h \end{array} \quad \dashrightarrow \quad \begin{array}{c} t \\ / \quad \backslash \\ r \quad c \\ | \quad / \quad \backslash \\ H \quad h \quad l \end{array} \quad \text{(from (89b))}$$
- b.
$$\begin{array}{c} t \\ / \quad \backslash \\ r \quad c \\ | \quad | \\ L \quad l \end{array} \quad \dashrightarrow \quad \begin{array}{c} t \\ / \quad \backslash \\ r \quad c \\ | \quad / \quad \backslash \\ L \quad l \quad h \end{array} \quad \text{(from (89c))}$$
- c.
$$\begin{array}{c} t \\ / \quad \backslash \\ r \quad c \\ | \quad / \quad \backslash \\ L \quad h \quad l \end{array} \quad \dashrightarrow \quad \begin{array}{c} t \\ / \quad \backslash \\ r \quad c \\ | \quad / \quad \backslash \\ L \quad h \quad h \end{array} \quad \text{(from (89d))}$$
- d.
$$\begin{array}{c} t \\ / \quad \backslash \\ r \quad c \\ | \quad / \quad \backslash \\ H \quad h \quad l \end{array} \quad \dashrightarrow \quad \begin{array}{c} t \\ / \quad \backslash \\ r \quad c \\ | \quad / \quad \backslash \\ H \quad h \quad h \end{array} \quad \text{(from (89e))}$$

The default rules in (90) apply to the underspecified tone, deriving the following structure for the surface even tone 44:

- (93)
$$\begin{array}{c} t \\ / \quad \backslash \\ r \quad c \\ | \quad | \\ L \quad h \end{array}$$

The postulation of the underlying falling contour [hl] for the surface concave contour is justified by the sandhi behavior in verbal reduplication. The underlying falling tones exhibit different sandhi effects from the rest. With respect to the sandhi behavior of the second tone of reduplicated verbal phrases, the five tones fall into two

The Representation of Tone

classes based on their underlying contour. Relevant data are given below (J.-Y. Hou (1983:261)):¹⁹

- (94) a. 213-213 > 213-35
- | | |
|---------|----------|
| saŋ saŋ | "fan" |
| fəŋ fəŋ | "divide" |
- b. 535-535 > 535-55
- | | |
|-------------|-----------|
| ts'ɔ ts'ɔ | "stir" |
| ts'əu ts'əu | "look at" |
- c. 24-24 > 24-53
- | | |
|---------------|--------|
| tɕ'ieu tɕ'ieu | "seek" |
|---------------|--------|
- d. 44-44 > 31-53
- | | |
|-----------|-------------|
| suag suag | "calculate" |
| k'aŋ k'aŋ | "see" |
- e. 53-53 > 35-53
- | | |
|---------|--------|
| uŋ uŋ | "ask" |
| tʉŋ tʉŋ | "move" |

In verbal reduplication, the two surface concave tones, modulo the register of the first tone, have the same tone melody, namely 213/535-53. This is different from the reduplicated tone melodies of the other three tones. Note that 44 surfaces as 31 in verbal reduplication (94d), which is the reason we assigned L to the register of this tone by the default rule (90a).

19. The short tone 54 shows diachronic influence on the verbal reduplication tone melodies. If the syllable has a voiced onset historically, then the tone melody is that of the surface tone 53, in (94e), otherwise it has the same pattern as the even tone 44, in (94d).

The Representation of Tone

To derive the tone patterns in (94), we first consider the behavior of tones in phrase-final position. We observe that the underlying falling tones surface as the high rising tone 35; the other tones surface as 53. The observations can be accounted for by the rule in (95a):

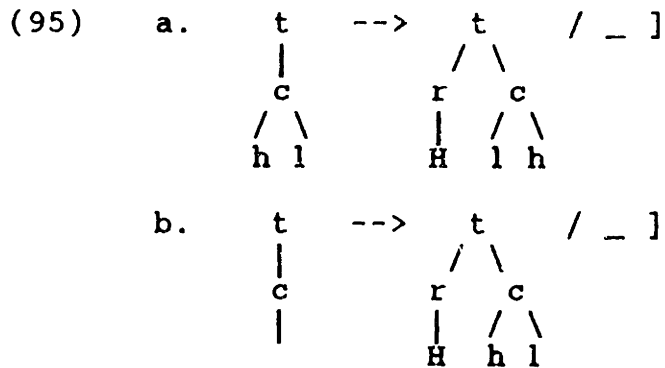

So tones in Changzhi form classes according to their c nodes. Note that 44 is unspecified underlyingly, but surfaces as 53 in phrase-final position. This indicates that the default rule applies before the rules in (95). Rule (95b) derives 53 from the underlyingly even tones 24 and 53 as well as the underlyingly unspecified tone 44. This rule is interesting formally in that the contour is falling regardless of the internal structure of the c node undergoing the rule. It only mentions the formal property of the c node, whether it branches or not.

The tones in the phrase-initial position can be derived by the feature-inserting rule (91). The derivation of the tone patterns of verbal reduplication is shown in (96); the

The Representation of Tone

derivation starts after reduplication:

(96)	I	II
	[L,hl]-[L,hl]	[H,hl]-[H,hl]
	Default Rules (90a,b)	not applicable
	(95a,b)	
	[L,hl]-[H,lh]	[H,hl]-[H,lh]
	Contour Formation (91)	
	[L,hlh]-[H,lh]	[H,hlh]-[H,lh]
	(213-35)	(535-35)
	III	IV
	[L,l]-[L,l]	[H,h]-[H,h]
	Default Rules (90a,b)	not applicable
	(95a,b)	
	[L,l]-[H,hl]	[H,h]-[H,hl]
	Contour Formation (91)	
	[L,lh]-[H,hl]	[H,hl]-[H,hl]
	(24-53)	(53-53)

V



Default Rules (90a,b)

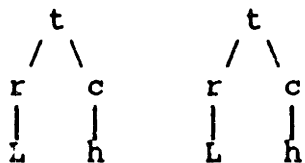

(95a,b)

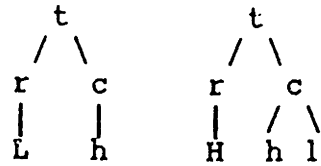

Contour Formation (91)

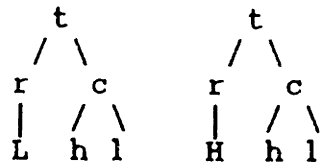

(31-53)

In (96IV), however, we derived the ill-formed pattern *53-53, instead of 35-53. Note that Contour Formation (91) creates two identical tones, both are high-registered falling tones. We therefore need a contour metathesis rule which changes the falling contour to rising just in case it is followed by another falling tone. The rule is given in (97):

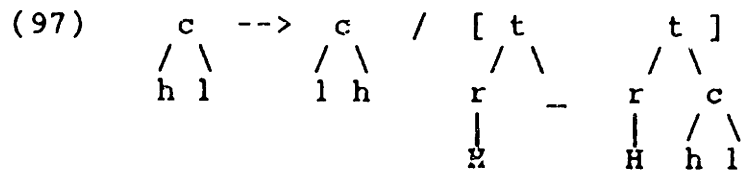

The register of the first tone must be specified so as to rule out the low falling tone 31 in (96V). The derivation of (96IV) continues:

The Representation of Tone

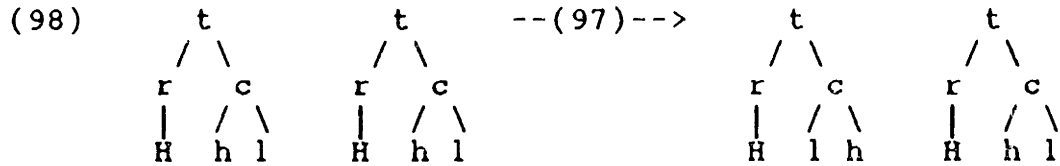

The Changzhi facts demonstrate that underlying tones may have completely different contours than the tones that surface, due to the various rules which may apply during the derivation of surface tones. The proposition that convex and concave tones are derivative is thus confirmed by the Changzhi verbal reduplication data.

3.4.2.2 Xining

Another dialect which demonstrates the surface nature of complex contours is Xining, to which the analysis of surface complex tones in Changzhi can be extended. Xining has four tones, as follows (all Xining data are taken from C.-C. Zhang (1980:290)):

(99) Xining Tonal Inventory:

- a. 44: ma "ant"; ta "dejected"
- A. 24: ma "hemp"; t'â a surname
- b. 53: ma "horse"; ta "beat"
- c. 213: nu "hungry"; ta "bid"

Now consider the bisyllabic tone patterns in (100)

through (103), where N is the neutral tone, and [v] is syllabic:²⁰

(100) a. 44-44 > 44-N

kw ta	"collusion"
ɕj kua	"watermelon"
ɕiẽ sɿ	"private thoughts"
tuẽ ɕj	"thing"

b. 44-24 > 44-N

ia t'w	"girl"
tʂa ɕɿ	"solid"
tẽ luẽ	"lantern"
ɕõ liõ	"consult"

c. 44-53 > 44-N

sẽ k'w	"draft animal"
tʂuẽ tẽ	"middle grade"
põ ɕw	"aide"
kuã k'a	"check point"

20. In Xining, tone sandhi does not take place in all bisyllabic phrases. Consider the two phrases in (i):

- (i) a. iẽ t'iã "cloudy day"
44-44 > 44-44
- b. tuẽ piã "east side"
44-44 > 44-N

Both have the same syntactic structure, but (ia) does not undergo tone sandhi, whereas (ib) does. The cause for this difference is obscure, and I assume that it is lexical. In (100) I only give the patterns of the phrases which do show sandhi effects. Some phrases with the pattern 44-24 surface as 44-44, rather than 44-N. (ii) is an example:

- (ii) tɕiẽ niã "this year"
44-24 > 44-44

Again, this appears to be lexically conditioned.

The Representation of Tone

d. 44-213 > 44-N

tɕiõ ts'w	"make do"
kuõ to	"fair"
ma j	"ant"
yu liõ	"moon"

(101) a. 53-44 > 53-N

ma tɕE	"horse wagon"
ta t'iõ	"find out"
tɕ'ɛ ɕiõ	"care for"
tiã ɕiõ	"snack"

b. 53-24 > 53-N

p'ɔ fa	"upset"
tɕiw ɕj	"banquet"
tɕv sɿ	"main food"
tɕõ t'w	"pillow"

c. 53-53 > 53-N

lu liã	"troublesome"
ɛ tu	"ear"
lɔ xv	"tiger"
ɕio uã	"small bowl"

d. 53-213 > 53-N

ta suã	"plan"
niã luei	"tear"
põ sɿ	"talent"
pã tõ	"bench"

(102) a. 24-44 > 21-53

miã xua	"cotton"
liõ kã	"decisive"
ma ta	"troublesome"
liõ ɕy	"neighbor"

b. 24-24 > 21-53

ma fã	"trouble"
miõ pei	"clear"
p'v t'ɔ	"grape"
niw lõ	"cowboy"

The Representation of Tone

c. 24-53 > 21-53

ts'ɛ xu	"match"
tʂ'ʂ t'v	"dust"
ʂiʂ l	"luggage"
liʂ fʂ	a pastry

d. 24-213 > 21-53

ʂl xua	"honest words"
liʂ k'ue	"cool"
t'v tsɿ	"apprentice"
niw ʂw	"beef"

(103) a. 213-44 > 21-53

tsɿ fʂ	"place"
kɔ tʂia	"self"
tʂ'j tʂ'ɛ	"car"
j sɿ	"meaning"

b. 213-24 > 21-53

ue xʂ	"novice"
ʂiw ts'ɛ	"intellectual"
iʂ tʂ'w	"entertain (guests)"
suã p'ã	"abacus"

c. 213-53 > 21-53

sɔ tʂv	"bloom"
tɔ xu	"wood burner"
pɔ tsɿ	"newspaper"
ʂiɔ tʂʂ	"principal"

d. 213-213 > 21-53

uei tɔ	"taste"
ʂiɔ xua	"joke"
ky sɿ	"story"
t'ɛ xw	"empress"

The tone patterns are summarized below (the horizontal axis is the second tone of a bisyllabic phrase; the vertical axis is the first tone):

The Representation of Tone

(104)	44	53	24	213
	44	44-N	44-N	44-N
	53	53-N	53-N	53-N
	24	21-53	21-53	21-53
	213	21-53	21-53	21-53

The sixteen bisyllabic patterns neutralize into three phrasal tone melodies: 44-N, 53-N and 21-53. It is clear from the data that the second tone plays no role in tone sandhi, the phrase-initial tone determines the tone melody of the bisyllabic phrase. If the initial tone is 44, the bisyllabic tone melody is 44-N; if 53, it is 53-N. Interestingly, the behavior of the concave tone 213 is identical to that of the rising tone 24. Both surface in the melody 21-53. The sandhi behavior of the surface concave tone gives strong evidence that it is derived from a tone with an underlying rising contour. Assuming the structures of Xining tones to be (105),

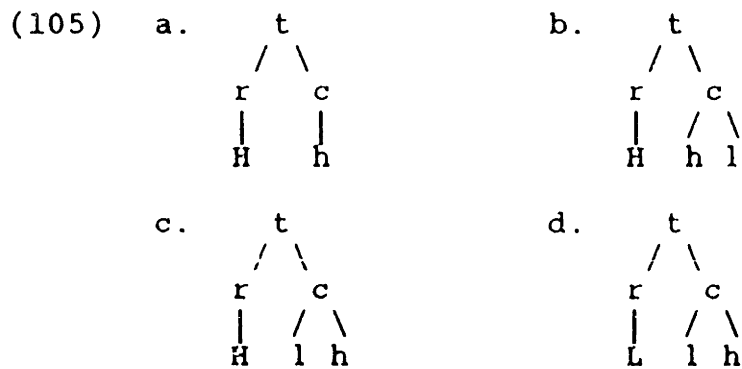

we can derive the surface bisyllabic tone patterns with the

following two rules:²¹

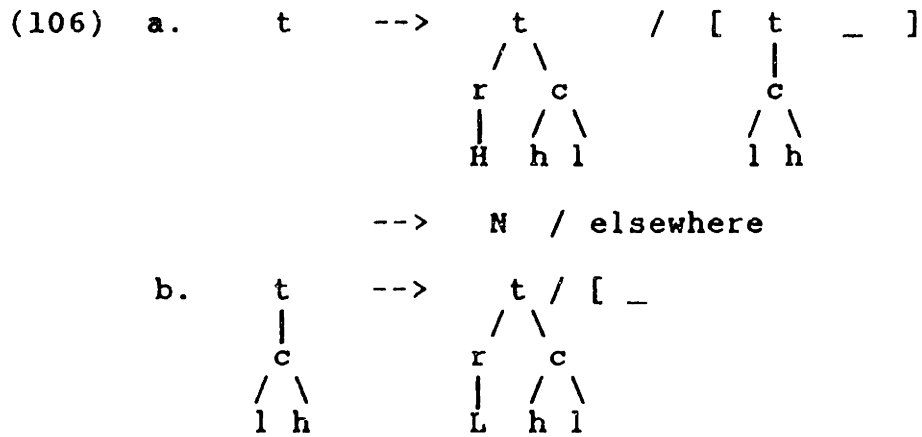

In the two rules the rising contour [lh] is crucial: all tones become high falling 53 following the rising tones, otherwise N (the content of rule (106a)); the rising tones become the low falling tone 21 phrase-initially, otherwise the lexical tone remains in phrase-initial position (the content of (106b)). The following derivation illustrates (T is any tone):

21. If we treat the neutral tone as lack of tone, then the mechanism of deriving the tone patterns will involve the deletion of the phrase-final lexical tones. The elsewhere clause of rule (106a) will not be necessary.

(107)

[H,h]-T [H,h1]-T [H,lh]-T [L,lh]-T

Rule (106a)

[H,h]-N [H,h1]-N [H,lh]-[H,h1] [L,lh]-[H,h1]

Rule (106b)

[H,h]-N [H,h1]-N [L,h1]-[H,h1] [L,h1]-[H,h1]

(44-N) (53-N) (21-53) (21-53)

Note that if the surface concave tone is also underlyingly concave, we can not group 24 and 213 as belonging to the same class. It would be simply accidental that the two tones exhibit the same sandhi behavior. By assuming that the surface concave tone is derived from an underlying rising tone, we provide an explanation why the two tones 24 and 213 should behave in the same way in tone sandhi. The two tones (105c,d) form a class by virtue of the fact that they have the same underlying contour. The surface concavity of (105d) in citation form can be derived by inserting [+slack] to its c node:

(108)

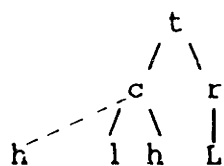

The sandhi data from Changzhi and Xining demonstrate that complex contours (concavity and convexity) can be fruitfully analyzed as derived from simpler underlying

The Representation of Tone

contours by means of feature-inserting rules.

3.4.3 Contour Simplification

There are three types of operation which may affect the c node: feature insertion, metathesis and simplification. We have seen instances of feature insertion and metathesis. The results of feature insertion and metathesis are unique: metathesizing the falling contour gives the rising contour, and vice versa. Contour simplification is non-unique. It produces two distinct representations from a falling or rising contour:

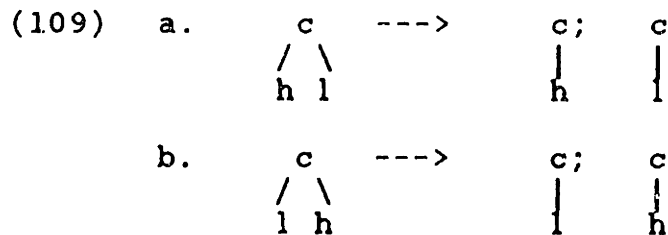

One way to constrain the dual possibilities and ensure uniqueness for contour simplification is to stipulate that for a tone language which exhibits such tone sandhi phenomena, contour simplification is either (110a) or (110b):

(110) a. Left Simplification:



b. Right Simplification:



The process of left simplification truncates the left branch of the c node; and that of right simplification truncates the right branch of the c node. Other things being equal, if a language which contains rising and falling tones employs either one of the simplification rules in (110), we expect to see two even tones with distinct c node specification as a result of simplification. The so-called Min Circle of the Xiamen dialect (Amoy Hokkien) provides interesting data which indicate that contour simplification has the properties just described. In Xiamen a tone undergoes sandhi in non-phrase-final position regardless of the following tone. This kind of tonal change is not sensitive to phonological environment; a tone in citation form corresponds one-to-one to a tone in sandhi form. The citation tones are given in (111), and the sandhi data in (112) (R. Cheng (1968:23-5)):²²

- | | | | | |
|-------|-------|------------------|-------|---------------|
| (111) | a. 55 | sig "rise" | b. 35 | sig "succeed" |
| | c. 53 | sig "save" | d. 31 | sig "holy" |
| | e. 33 | sig "prosperous" | | |

22. In our discussion of Xiamen tone sandhi short tones 31 (sik 31 "clever") and 55 (sik 55 "cooked") are omitted. The Xiamen data have been studied extensively. Among the studies are Yip (1980), Wright (1983) and Shih (1986).

The Representation of Tone

- (112) a. 55 -> 33
 sã 55 "three" > sã 33 ki 55 "three pieces"
- b. 35 -> 33
 bæ 35 "no" > bæ 55 cĩ 35 "no money"
- c. 33 -> 31
 c'ue 33 "look for" > c'ue 31 bĩ? 3
 "look for things"
- d. 31 -> 53
 si 31 "four" > si 53 ki 55 "four pieces"
- e. 53 -> 55
 kau 53 "nine" > kau 55 ki 55 "nine pieces"

The sandhi patterns in (111) are arranged in a circular fashion in (113), hence the term *Min Circle*:

- (113) 55,35 -> 33 -> 31 -> 53 -> 55

In order to derive the *Min Circle*, I assume that the tones in (113) have the underlying structures in (114):

- (114) a. $\begin{array}{c} t \quad (55) \\ / \quad \backslash \\ r \quad c \\ | \quad | \\ H \quad h \end{array}$ b. $\begin{array}{c} t \quad (35) \\ / \quad \backslash \\ r \quad c \\ | \quad / \quad \backslash \\ H \quad l \quad h \end{array}$
- c. $\begin{array}{c} t \\ / \quad \backslash \\ r \quad c \\ | \quad | \\ L \quad h \end{array}$ or $\begin{array}{c} t \quad (33) \\ / \quad \backslash \\ r \quad c \\ | \quad | \\ H \quad l \end{array}$

The Representation of Tone

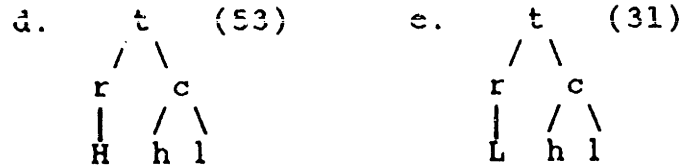

Note that the mid even tone 33 is ambiguously specified as [L,h] or [H,l], which are neutralized phonetically.

Observe that the high rising tone 35 and the high falling tone 53 both surface in the even contour: 35 becomes the low even tone 33 (112b), and 53 becomes the high even tone 55 (112e). In other words, the rising and falling contours undergo the right simplification rule formulated below:

(115) Contour Simplification

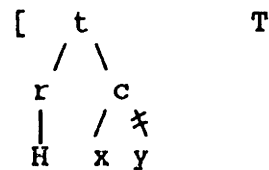

In rule (115), the H register must be specified so as not to affect the low falling tone 31; T is any tone. The rule simplifies the contour by delinking its right branch; the left branch is still dominated by the c node. The results of Contour Simplification (115) are given below:

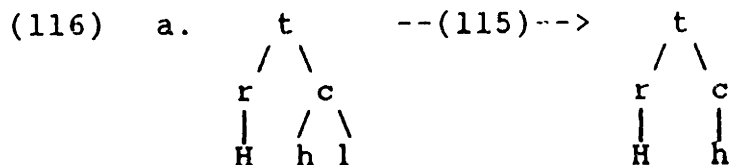

The Representation of Tone

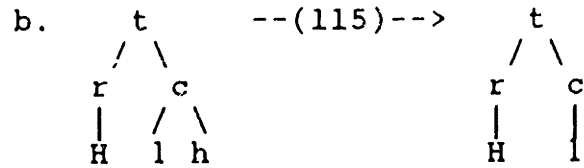

In addition, the high even tone 55 [H,h] lowers to 33 [H,l]. Formally the 55>33 alternation involves changing the value of [slack] from [-slack] to [+slack]. The h>l lowering could be accounted for by a rule which does just that. But in view of the fact that the high rising tone 35 undergoes Contour Simplification and surfaces as 33, we can derive the 55>33 by first changing 55 to 35, and then simplify the rising contour by rule (115). The rule which derives a rising tone from 55 is given in (117):

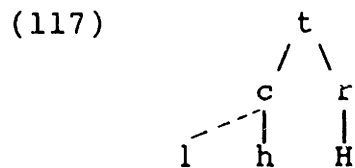

Rule (117) must be ordered before Contour Simplification (115), because the former feeds the latter: (117) produces the structure [H,lh] from [H,h]. We need the two rules in (118) and (119):

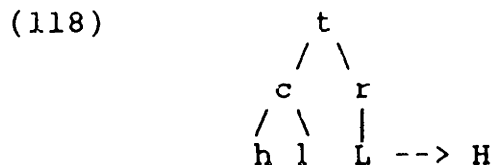

The Representation of Tone

(119)

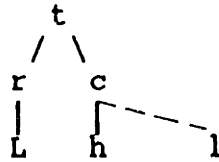

The derivation of the sandhi patterns follows. The rules must be applied in the order given:

(120)	a	b	c	d	e
	[H,h]	[H,h1]	[H,1h]	[L,h]	[L,h1]
	(114a)	(114d)	(114b)	(114c)	(114e)
(117)	[H,1h]	--	--	--	--
(115)	[H,1]	[H,h]	[H,1]	--	--
(118)	--	--	--	--	[H,h1]
(119)	--	--	--	[L,h1]	--
	33	55	33	31	53

The rule of interest is Contour Simplification (115): it generates a high even tone from a falling tone (cf. (120b)) and a mid even tone from a rising tone (cf. (120a,c)). This indicates that contours are not atomic entities; they are composed of the two terminal nodes of the

c node.²³

The analysis of the Xiamen data underscores a property of the mid even tone. In languages with fewer than four even tones, it is theoretically possible to represent the mid even tone 33 as either [H,l] or [L,h]. In other words, the mid even tone may be structurally ambiguous. In such

23. Wang (1967:103), using the primitive contour features [falling] and [rising], defines the Xiamen tones as follows:

	55	35	53	31	33
HIGH	+	+	+	-	-
FALLING	-	-	+	+	-
RISING	-	+	-	-	-

He captures the *Min Circle* in a single rule schema,

(i) $\left[\begin{array}{l} \alpha\text{high} \\ \beta\text{falling} \end{array} \right] \rightarrow \left[\begin{array}{l} \beta\text{high} \\ -\alpha\text{falling} \end{array} \right]$

from which the following rules can be extracted:

(ii) $\alpha=+; \beta=+$

$\left[\begin{array}{l} +\text{high} \\ +\text{falling} \end{array} \right] \rightarrow \left[\begin{array}{l} +\text{high} \\ -\text{falling} \end{array} \right]$

(iii) $\alpha=+; \beta=-$

$\left[\begin{array}{l} +\text{high} \\ -\text{falling} \end{array} \right] \rightarrow \left[\begin{array}{l} -\text{high} \\ -\text{falling} \end{array} \right]$

(iv) $\alpha=-; \beta=+$

$\left[\begin{array}{l} -\text{high} \\ +\text{falling} \end{array} \right] \rightarrow \left[\begin{array}{l} +\text{high} \\ +\text{falling} \end{array} \right]$

(v) $\alpha=-; \beta=-$

$\left[\begin{array}{l} -\text{high} \\ -\text{falling} \end{array} \right] \rightarrow \left[\begin{array}{l} -\text{high} \\ +\text{falling} \end{array} \right]$

See also Wright (1983) on the *Min Circle*.

languages these two structures are not contrastive, therefore there is no phonological reason to rule out the structural ambiguity for the mid even tone. In fact, this property of the mid even tone may be empirically desirable. In the case of the *Min Circle*, we need not formulate rules to adjust the register and contour specifications from [H,l] to [L,h]. Their contrast is neutralized phonetically. In Chapter Six I will discuss a language (Weining Miao) which demonstrates further the advantage of dual structures for the mid even tone.

The rules involved in the derivation of the *Min Circle* are formally quite simple. There is the delinking rule (115), the lowering rule (117), the raising rule (118), and the feature-inserting rule (119). These are the elementary types of phonological rule that are widely used in segmental phonology (see Chomsky and Halle (1968), Clements (1989)). I will discuss rule types in tone sandhi in Chapter Five.

3.5 Tone and The Geometry of the Laryngeal Features

In the preceding I presented empirical evidence which establishes the tonal geometry shown in (121):

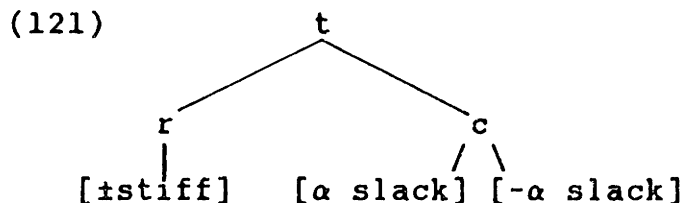

The Representation of Tone

The features in the structure are the laryngeal features [stiff] and [slack] of Halle and Stevens (1971). They perform different formal and conceptual roles in the tonal geometry. Formally the r node, which does not branch, specifies the register, while the c node, which optionally branches, specifies the contour. Conceptually, the r node represents the static aspect of tone, and the c node represents the dynamic aspect of tone. The use of a single feature [stiff] to specify both the tonal register and the voicing qualities of obstruents readily accounts for the correlation between voicing and tonal register in languages such as Songjiang (cf. (10)). As we have shown, the geometry of tone in (121) is supported by empirical evidence. In this section I argue that the structure of tone is a substructure of the laryngeal node.

Sagey's (1986) feature geometry is given below for reference (the square brackets are added to the features):

The Representation of Tone

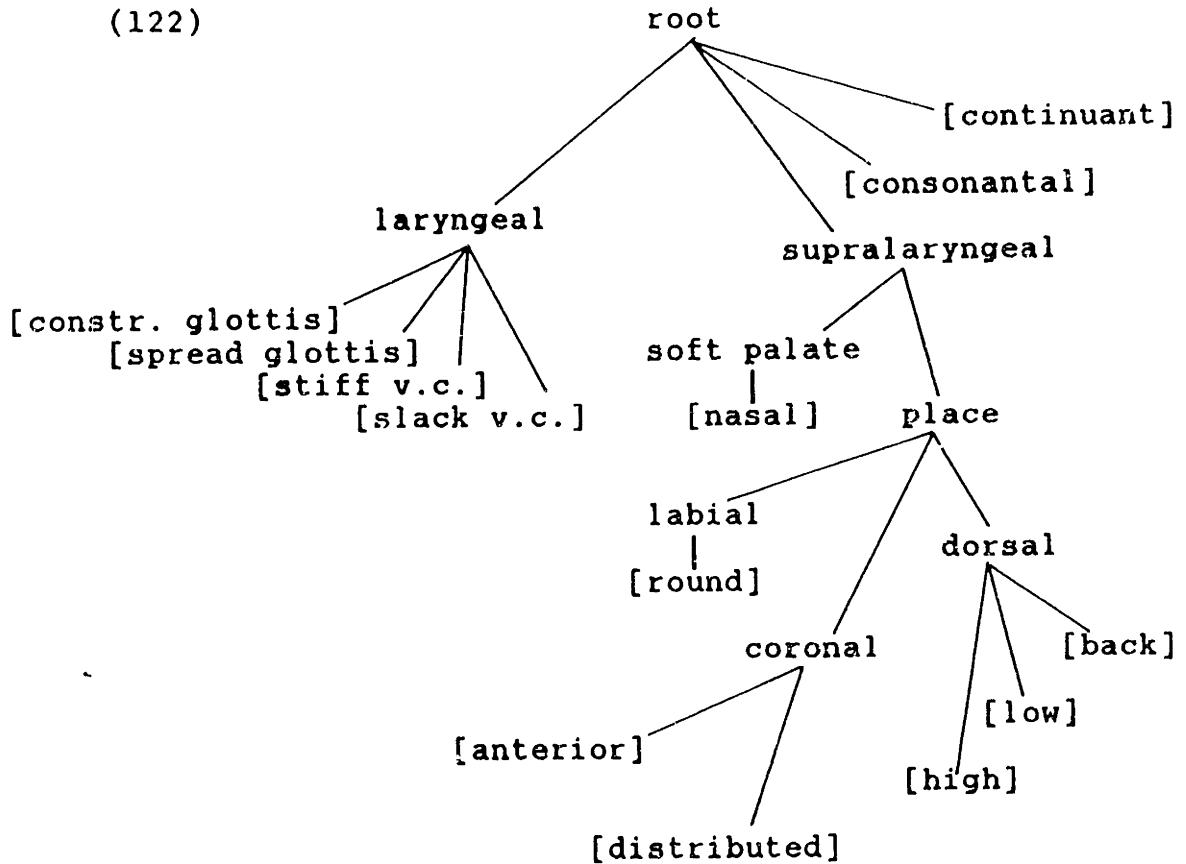

In the theory of feature geometry proposed by Sagey (1986) and Halle (1986,1989), the central idea is the conception of features as describing the articulatory behaviors of the articulators (see also Halle (1983)). Thus, the feature [anterior] and [distributed] describe the articulatory gestures of the coronal articulator. The relationship between features and articulators is one of phonetic execution. This relationship is captured in the tree formalism as dominance: features are terminal nodes dominated by articulator nodes. In (122), [nasal] and [round] are examples of such features, since they are

The Representation of Tone

dominated by the articulator nodes *soft palate* and *labial* respectively. Features may also be dominated by the root node, such as [consonantal] and [sonorant]. Halle (1989) calls these "stricture features." Stricture features must be executed by an articulator as well, which is expressed formally by the pointer device. The pointer links the root node of a segment to the articulator where the stricture features are executed. In (123), by virtue of the fact that the pointer points at the coronal node, the features immediately dominated by the root node are executed by the articulator coronal (Sagey (1986:207)):

(123)

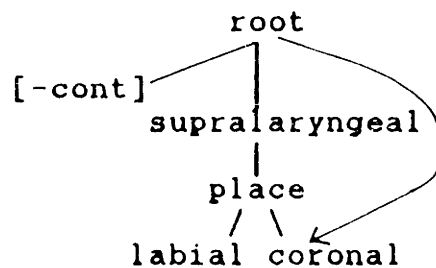

We will focus on the laryngeal node. Note that in Sagey's feature tree the laryngeal node dominates four terminal features: [constricted glottis], [spread glottis], [stiff vocal cords] and [slack vocal cords]. It lacks internal structure. Halle (1989) proposes the structure in (124), in which Sagey's laryngeal node (LAR) is renamed as the Glottal (GL) node:

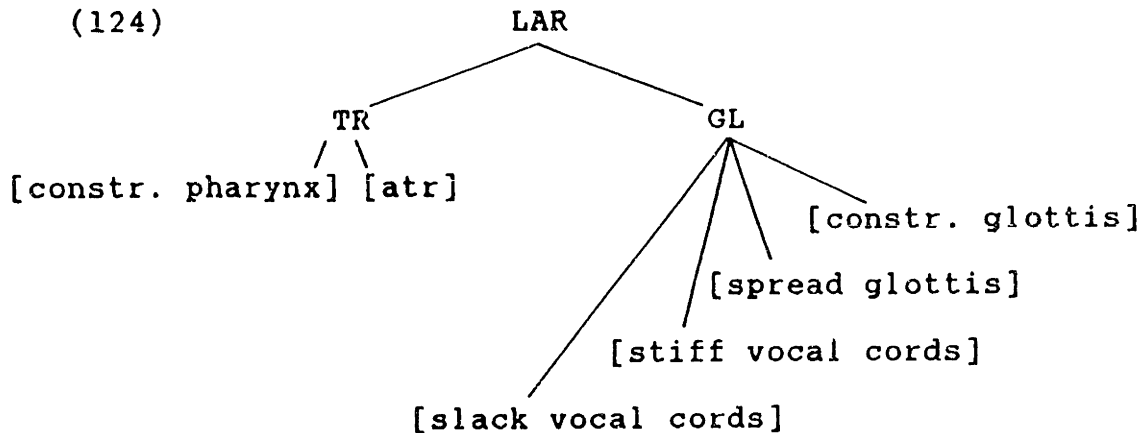

This structure is described in the proposition P-3 of Halle (1989:17):

- P-3: In the feature tree the features [Constricted Pharynx] and [ATR] are executed by the Tongue Root (TR) articulator; the features [constricted glottis], [spread glottis], [stiff vocal cords], [slack vocal cords] are executed by the Glottal articulator (i.e., the vocal cords). The TR and Glottal nodes are directly dominated by the LARYNX node.

In Halle's structure, the laryngeal node dominates the Glottal node and the Tongue Root (TR) node. The TR node is proposed in response to McCarthy's (1989) work on Arabic gutturals, where he proposes the node Pharyngeal which docks under the Place node, see McCarthy (1989) for details.

The four features under the GL node can be classified into two types based on the articulatory instructions they give to the Glottal articulator. On the one hand, the features [constricted glottis] and [spread glottis] describe laryngeal activities which affect the glottis, i.e. the

degree of opening between the vocal cords. On the other hand, the features [stiff vocal cords] and [slack vocal cords] describe activities which affect the degree of tension of the vocal cords. Thus, [constricted glottis] and [spread glottis] do not describe the same articulatory event of the larynx. Based on this observation, I propose the structure of the Laryngeal node in which the Vocal Cords (VC) node dominates the features [stiff (vocal cords)] and [slack (vocal cords)] and the GL node dominates [constricted (glottis)] and [spread (glottis)], as in (125):

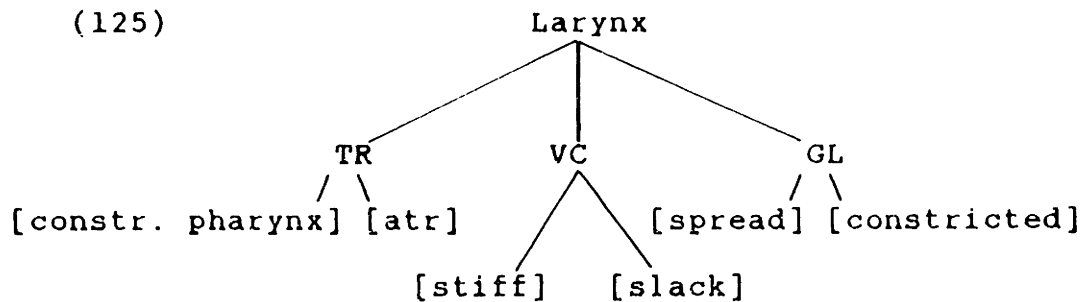

In the tree structure (125), the VC node dominates the features [stiff] and [slack]; the tension of the vocal cords is determined by the interaction of the two features. Since tones arise from the linguistic use of pitch, they are controlled by the vocal cord tension (Lehiste (1970), Halle and Stevens (1971), Ohala (1972,1977), Ladefoged (1975), Hirose (1976), Fujimura (1977), Stevens (1977,1981), Harvey and Howell (1980), Hirano (1981), Hirose and Sawashima (1981), Sawashima and Hirose (1983), Collier and Gelfer

(1984), Alipour-Haghighi et al (1989)). In other words, we can say that tones are directly related to the tension of the vocal cords. To represent it in terms of tree formalism, I propose that the t node in the tone geometry (121) is in fact the geometry of the Vocal Cords node. This means that the Vocal Cords node in (125) has the structure in (126):

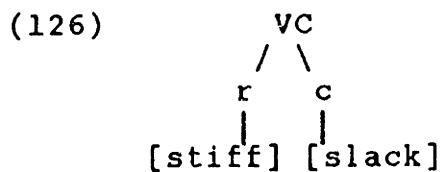

In Sagey's theory, terminal features are dominated by articulator nodes. Thus, the relationship between the r node and [stiff] on the one hand, and the c node and [slack] on the other, is one of phonetic execution: the r node is the articulator that executes the feature [stiff] and the c node is the articulator that executes the feature [slack]. The interaction of the two articulators determines the degree of stiffness of the vocal cords, which gives rise to the pitch differences in tones.

The geometry of tone leads us to certain expectations of the articulatory behaviors of the laryngeal articulators. In Halle and Stevens's original interpretation, the two features [stiff] and [slack] represent the opposite ends of the stiffness scale; hence [+stiff] and [+slack] can not be executed phonetically at the same time. My interpretation of

The Representation of Tone

the two features, which allows the combination of [+stiff] and [+slack], implies that the features are independently controlled articulatorily. The structure in (126) is the formal device that captures this conception. The feature [stiff] provides the articulatory instructions to the relevant laryngeal muscles to increase or decrease the overall tension of the vocal cords, which we take to be the tonal register. Within the register, the feature [slack] acts over time to micro-adjust the physical properties of the vocal cords which result in modification of the acoustic realization of tone. Note that the temporal notion of tone (i.e. the dynamic aspect) is captured formally in terms of the c node. If it branches, the two branches of the feature [slack] are temporally significant -- over the duration of the tone bearing unit they provide different articulatory instructions to the same articulator. Given the conception of the feature tree as the formal representation of a sectional view of speech sounds, c node branching can be viewed as organized along the time domain -- it is orthogonal to the feature tree. If the c node is non-branching, the feature [slack] provides the same articulatory instructions to the same articulator over the duration of the tone bearing unit. The instruction of the feature [slack] is responsible for either changing or maintaining tonal pitch within the register set by the

The Representation of Tone

feature [stiff]. The dynamic aspect of tone is relativized to its static aspect.

The conception of the geometry of tone as a substructure of the geometry of laryngeal features leads us to the conclusion that the r node and the c node must represent separate laryngeal articulators. The attempt to identify them with laryngeal muscles is made difficult by the lack of conclusive evidence that establishes causal relationships between laryngeal muscular activities and their acoustic effects. In the following discussion I sketch in brief and speculative terms the laryngeal physiology in the hope of identifying the laryngeal muscle(s) with the r and c nodes.²⁴

The view that vocal cord tension regulates pitch is relatively uncontroversial (see references cited above). Many factors are involved in the tensing of the vocal cords, and there is perhaps no one-to-one correspondence between the stiffness of the vocal cords and activities of any single laryngeal muscle to the exclusion of other muscles. However, the major source of vocal cord tension is the

24. Strictly speaking, articulator nodes, such as coronal and dorsal, represent regions of the vocal apparatus, rather than the muscles which control them. The node VC (vocal cords) is an articulator in this sense. Tone is executed by the same articulatory region (the vocal cords) whose physical properties may be adjusted by the activities of various muscles. It is not sufficient to refer to the region to differentiate tonal effects.

The Representation of Tone

vertical movement of the larynx, which increases or decreases the tension of the vocal cords along the longitudinal dimension. While the longitudinal tension of the vocal cords has been shown to play a major role in pitch control (see references cited above), the transverse tension also participates in regulating pitch. The muscle which elongates the vocal folds is the cricothyroid (CT) muscle and the vocalis (VOC) is responsible for the thickness of the vocal cords. In their own ways the activities of the two muscles contribute to the tension of the vocal folds, giving rise to different vocal pitch. According to Sawashima and Hirose (1983:21-22),

The activity of both muscles [the CT and vocalis -- Bao] increases for raising pitch and decreases for lowering pitch...contraction of the cricothyroid muscle elongates the vocal folds. The results are a decrease in the effective mass and an increase in the stiffness of both the body and the cover. Contraction of the vocalis muscle results in a thickening of the vocal folds, their effective mass being increased. The stiffness of the body increases while that of the cover decreases.

The cover and body are two components of the vocal cords, i.e., folds (Hirano et al (1981)). Sawashima and Hirose continue to suggest that the activities of the cricothyroid and the vocalis may provide good physiological correlates of the two features [stiff] and [slack] proposed in Halle and Stevens (1971). Despite the lack of firm experimental data, this suggestion is interesting in that it makes it possible

The Representation of Tone

to interpret the features [stiff] and [slack] as independent parameters of vocal cord tensing. Each of the two features may involve a multitude of physiological factors. The feature [stiff] may be viewed as the main source of tensing, executed chiefly by the cricothyroid muscle along the longitudinal dimension. The feature [slack] is the secondary source of tensing, and among the muscles involved is the vocalis muscle (see Harvey and Howell (1980) and Alipour-Haghighi et al (1989) for interesting discussion on the possible relationship between activities of the vocalis muscle and fundamental frequency change. Hirano (1981) shows that the vocalis muscle actively participates in pitch regulation in singing). In other words, we may identify the cricothyroid muscle with the r node, and the vocalis with the c node. The geometry in (126) may be recast as (127):



The r node is the node labeled CT, for the cricothyroid muscle which is chiefly responsible for vocal cord tensing; the c node is the node labeled VOC, for the vocalis muscle, which further modifies the physiological properties of the vocal cords. The t node is the node labeled VC. The CT and VOC nodes are the articulators which execute the features

The Representation of Tone

[stiff] and [slack] respectively.

We have identified the cricothyroid muscle as the laryngeal articulator which determines the tonal register and the vocalis muscle as the laryngeal articulator which modifies the temporal realization of pitch within the register. Such identification does not preclude possible side effects of muscular activities within the larynx which lead to modification in pitch. Maddieson (1974:24) gives four tone-affecting factors: 1) sub-glottal pressure; 2) supraglottal pressure; 3) width of glottal opening and 4) vocal cord tension, which is "dependent on tension of the cricothyroid and other laryngeal muscles." Muscular activities which determine the degree of opening of the glottis may affect the stiffness of the vocal cords. This may conceivably result in pitch difference. I take such pitch effects as phonetic details with little phonological relevance.

The laryngeal structure proposed by Halle (1989), as modified in (125), looks like this:

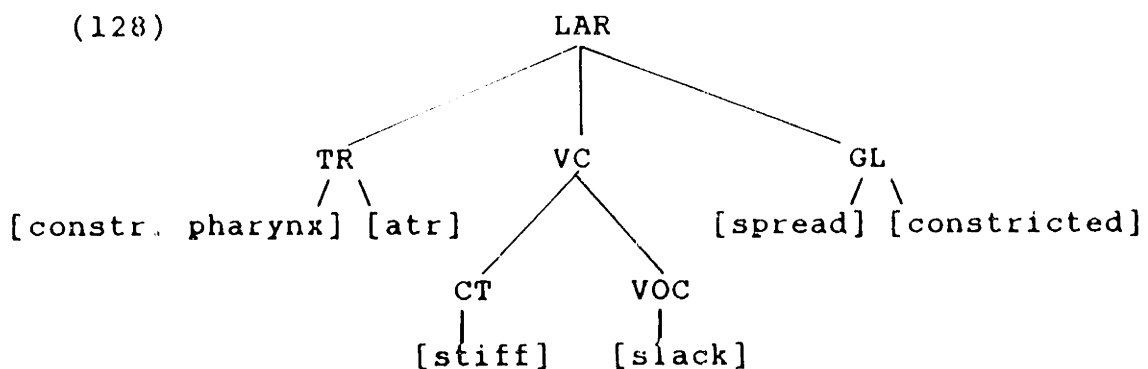

The Representation of Tone

The node GL is the articulator which executes the features [spread] and [constricted], for which I have nothing further to say. The node VOC (i.e. the c node) optionally branches, which is not stated in the laryngeal feature tree (128).

3.6 Contour System versus Level System: a Parametric View

It has been observed that tone languages fall into two general types, contour system versus level system. Pike (1948:8) states the differences as follows:

- Contour systems differ from register systems [i.e. level systems --Bao] in a number of points: (1) The basic tonemic unit is gliding instead of level. (2) The unitary contour glides cannot be interrupted by morpheme boundaries as can the nonphonemic compounded types of a register system. (3) The beginning and ending points of the glides of a contour system cannot be equated with level tonemes in the system, whereas all glides of a register system are to be interpreted phonemically in terms of their end points. (4) In the printed material examined contour systems had only one toneme per syllable, whereas some of the register tone languages, like the Mazateco, may have two or more tonemes per syllable.

In the theory being developed here, a contour system can be formally characterized in terms of a branching c node. This contrasts with a level system, which does not allow the c node to branch. To capture Pike's insight, I propose the Contour Parameter as follows:

The Representation of Tone

(129) The Contour Parameter

In the structure

$$\begin{array}{c} t \\ / \quad \backslash \\ r \quad c \end{array}$$

with (a) and (b) as the structures of c

(a) $\begin{array}{c} c \\ | \end{array}$ (b) $\begin{array}{c} c \\ / \quad \backslash \end{array}$

A tone system is level if and only if its tones have the c node structure (a)

A tone system is contour if and only if its tones have the c node structure (b) and/or the c node structure (a)

The typological difference between the two tone systems that Pike recognizes is parameterized in terms of the structural configurations of the c node. With the possibility of a branching c node a contour system is more complex structurally than a level system. A tone language contains a setting of the Contour Parameter, and is expected to exhibit tonal properties in accordance with its parametric setting. The properties of the two systems need not be disjoint. In fact we would expect a contour system to exhibit properties that are also found in a level system, but not vice versa, since a contour system may have level (i.e. even-contoured) tones in its tonal inventory, while a level system may not have contour tones in its tonal inventory. A level system, however, may lack tonal properties that are found in a contour system, particularly properties related to the c node. Given the formal

apparatus, the properties given by Pike in the above quoted passage may be interpreted as follows:

- (130) a. In a contour system, contours are basic in a contour system; in a level system they are derivative (cf. Pike's (1)).
- b. In a contour system contour remains intact under morpheme concatenation; in a level system it dissolves (cf. Pike's (2)).
- c. In a contour system, the end points of a contour tone result from the interaction between the branching c node and the r node, hence contour is relativized to register; in a level system the end points are independent (cf. Pike's (3)).
- d. In a contour system, the relation between tone bearing units and tones is one-to-one; in a level system, it is one-to-many (cf. Pike's (4)).

In addition to the above properties, the distribution of contour tones in a contour system differs from that in a level system. This is stated below:

- (130) e. Distributionally, contour tones are free in a contour system; but restricted to peripheral positions in a level system (Yip (1989)).

Unlike (130a,b,c), (130d) is not a direct consequence of the formal apparatus spelled out so far. Rather, it is partially a consequence of the Association Conventions (Goldsmith (1976a,b), Pulleyblank (1986)), which stipulate a one-to-one relation between tone bearing units and tones (see Chapter One). In a level system, contour tones, which

The Representation of Tone

are represented as a one-to-many association between tone bearing units and level tones, are a consequence of rule application (Pulleyblank (1986)). Contour tones can not be created in this manner in a contour system.

With respect to (130e), we have seen that in a contour system such as Danyang (§3.3.1.1) contour tones are not restricted to the edges of a domain (i.e. a phrase in Danyang). They occur freely. Yip (1989:153) gives examples of Mandarin Chinese borrowings which show the contour tone 35 to occur phrase-initially (131a,e), phrase-medially (131c,d) and phrase-finally (131a):

(131)	a.	He 35 lan 35	"Holland"
	b.	Ma 315 ke 51 si 55	"Marx"
	c.	Qiu 55 ji 35 er 315	"Churchill"
	d.	qiao 315 ge 35 li 51	"chocolate"
	e.	mo 35 tuo 55	"motor"

In a level system, however, the distribution of contour tones is restricted. It is best illustrated by Tiv. According to Pulleyblank (1986), contour tones in Tiv only occur in word-final position. This can be seen from the data below (Pulleyblank (1986:216)):

(132)	a.	ùnyinyà mbâ	"there are horses"
	b.	íwá ngí	"there are dogs"
	c.	ngòhòr	"accepted (recently)"
	d.	swâm	"wild boar"

Pulleyblank shows that contour tones are created by a rule of T-attachment, which links "a final floating tone to the

last vowel of a word in pre-pausal position (p. 217)."

Given the formal difference in tonal geometry that the parametric settings entail, we will expect there to be tone sandhi processes which are found in one system but not in the other system. Hyman and Schuh (1974) enumerate the synchronic "universal tone rules" as follows:

- (133) a. downstep
b. tone shifting
 a tone shifts from one syllable to another
c. copying
 a toneless syllable receives a copy of the tone of the neighboring syllable
d. polarization
 a toneless syllable receives the opposite of the tone of the neighboring syllable
e. dissimilation
 an underlying tone changes to the opposite of the tone of the neighboring syllable
f. replacement
 an underlying tone is replaced by another
g. displacement
 "tonal contrasts are realized several syllables to the right of their original position." (p.103)

See also Hyman (1975). These rule types all exist in level systems. With regard to contour systems, we have seen the following types of tone sandhi process:

- (134) a. Assimilation
- b. Dissimilation
- c. Feature Insertion

Both assimilation and dissimilation involve tone as a melodic unit, register and contour. (133e), dissimilation, finds its counterpart in a contour system in the forms of register dissimilation and contour dissimilation. Due to the complex geometry of tone in a contour system, phonological processes are correspondingly more complex than those found in level systems.

3.7 Some Problematic Consequences of the Theory

The proposed theory of tone is capable of accounting for a wide range of tone sandhi facts found in contour tone languages. However, it has consequences which may turn out to be problematic. There are two areas where the theory could be falsified. First, the theory has no mechanism of handling the tonal effects of syllabic obstruents (if such things should exist). Since vowels are unspecified for the laryngeal features, the use of the vocal cord features [stiff] and [slack] for tones is not problematic. But laryngeal features must be specified for obstruents, particularly where they are distinctive. Potential problems arise when obstruents are interpreted as occupying the

The Representation of Tone

syllabic nucleus. Secondly, the theory is capable of accounting for four level (even-contoured) tones, two rising tones and two falling tones. A tonal inventory with five contrastive level tones, or more than two contrastive falling or rising tones, is a real problem for the theory. I now proceed to address these two issues.

3.7.1 Syllabic Nasals and Obstruents

First, consider the syllabic nasals of Wenzhou. Wenzhou has eight surface tones in citation form (all Wenzhou data are taken from Zhengzhang (1964)):

(135)	a.	44	pa p'a	"father" "climb"
	A.	31	ba	"firewood"
	b.	<u>45</u>	pa p'a	"board" sound of firecrackers
	B.	<u>34</u>	ba	a kind of fish
	c.	42	pa p'a	"act" "petal"
	C.	22	ba	"perform"
	d.	<u>323</u>	pa p'a	"hundred" "pat"
	D.	<u>212</u>	ba	"white"

The underlined tones are the so-called tense tones, as opposed to the lax tones, which are not underlined. The tones fall into two series: (135a-d) are the yin (i.e. H-

The Representation of Tone

registered) tones and (135A-D) are the yang (i.e. L-registered) tones. The tones (135a,A), (135b,B), etc., are in complementary distribution with respect to syllable-initial segments. In addition to voiced and voiceless obstruents, Wenzhou also has voiced and voiceless nasals, shown in (136):

- (136) voiceless
m̥; n̥; ɲ̥; ŋ̥
voiced
m; n; ɲ; ŋ

The circle below a nasal indicates voicelessness. The voiced velar nasal ŋ can be syllabic, as exemplified in (137):

- (137) a. ŋ 31 Wu, name of a region
b. ŋ 34 "I"
c. ŋ 22 "two"
d. ŋ 212 "fish"

Other syllabic nasals do not occur as lexical items, but may occur as interjections. One important property is that voiced syllabic nasals occur only with yang tones (i.e. L-registered tones); and voiceless syllabic nasals, if any, occur only with yin tones (i.e. H-registered tones). This is precisely the predicted result of the proposed theory: voicing is specified as [-stiff], which is also the

specification for the L register. So we have no difficulty in handling the Wenzhou voiced syllabic nasals. The difficulty is to explain how tonal effects come about in voiceless syllabic nasals. Since tone is pitch, and pitch depends on the vibration of the vocal cords (Lehiste (1970), Ladefoged (1975) and others), it would be difficult to explain the phonetic execution of H-registered tones realized on voiceless syllabic nasals.

A potentially more damaging case is syllabic obstruents. To my knowledge, only a few tone languages have been reported as having the syllabic [v]. Xining has lexical items with the syllabic [v] (C.-C. Zhang (1980)):

(138)	a.	with 44	f _v	"bran"
			tʂ'v	"out"
			f _v	"book"
			v'	"room"
	b.	with 53	x _v	"tiger"
			v'	"five"
			tʂ _v	"bloom"
			tʂ'v	"elbow"
			f _v	"rat"
	c.	with 213	v	"teacher"
			k _v	"past"
	d.	with 24	p'v	"grape"

As we have seen in §3.4.2.2, Xining has four tones: 44, 53, 213 and 24. So the syllabic [v] occurs with all tones, and with a wide range of obstruents in the onset. Interestingly, there are no voiced obstruents in Xining except [v], which,

The Representation of Tone

judging from the data given in C.-C. Zhang (1980), does not appear to occur in the onset. But the peculiar property of the sole voiced obstruent [v] does not make the problem disappear. The theory developed here predicts that the syllabic [v] occurs only with L-registered tones, but in fact it occurs with all the tones. We cannot say that the four tones in Xining are all L-registered tones, since, as we have done in §3.4.2.2, the contrast between the two tones 213 and 24 lies in their registers: the former is L-registered, the latter H-registered. So the syllabic [v], if it is indeed an obstruent, poses a problem for the theory.

Another language which exhibits the syllabic [v] is Bai, a language spoken in the southwestern part of China. This language has three tones realized on syllables with tense vowels; three tones realized on syllables with lax vowels; and one tone realized on syllables with both tense and lax vowels. The tones are exemplified as follows (Xu and Zhao (1964:323)):²⁵

(139)	Lax Vowel			Tense Vowel			
a.	33	to	"top"	e.	42	to	"big"
b.	31	to	"fight"	f.	44	to	"drop"
c.	55	to	"meet"	g.	21	to	"do"
d.	35	to	"do"	h.	55	to	"fight"

25. The authors of the field report do not provide detailed phonetic description of tense or lax vowels. They mark tense vowels and lax vowels with tones, as in (139).

The Representation of Tone

The even tone 55 occurs with both tense and lax vowels (cf. (139c,h)). For ease of exposition, I will call the tones (139a-d) lax tones and those in (139e-h) tense tones. There does not appear to be any correlation between pitch height and vowel tenseness. Syllabic [v] and its nasalized counterpart [ṽ] occur with both lax and tense tones:

(140)	Lax		
	a. 33	tsṽ ɔṽ	"wine" "five"
	b. 31	fṽ sṽ	"powder" "sick"
	c. 55	kṽ tṽ fṽ (-tɕa 42)	"call" "escape" "old friend"
	d. 35	(khw 35-) fṽ	"overcome"
	Tense		
	e. 42	fṽ ɔṽ	"tie" "ten thousand"
	f. 44	tsṽ tṽ thṽ t̃ṽ	"candle" "dig" "stop" "frozen"
	g. 21	kṽ	"group"

I am not able to find an example of tense syllabic [v] occurring with the tense high even tone 55 (note that 55 occurs with both tense and lax vowels). As in Xining, Bai does not have voiced obstruents other than [v] and its nasalized equivalent. As is evident from the data in (139),

The Representation of Tone

the syllabic obstruent [v] (and [ṽ]) in Bai occurs with all tones and there is no apparent phonotactic constraint on the onset.²⁶

Again, the tonal effects of the syllabic obstruent [v] contradicts the theory. I leave this issue open.

3.7.2 Unusual Tonal Inventories

The tone model being proposed here is capable of generating four even tones, two rising tones, and two falling tones, for a total of eight contrastive tones. The eight theoretically possible tonal contrasts are sufficient to account for the tonal inventories of the vast majority of tone languages. Languages with more than four level tones or more than two tones of each contour are problematic for the theory. They are, however, rare, a fact pointed out by W. Wang (1967) and Yip (1980). Even in the rare cases of five even tones, such as the Miao dialect reported in W. Wang (1967), we do not have tone sandhi facts which indicate whether the five phonetic even tones are phonologically even. The existence of five even tones (or

26. [v] can be used as an onset as well. The pronunciation differs. Xu and Zhao describe the phonetic characteristic of the syllabic [v] thus: the upper teeth lightly touches the lower lip, and the tongue position is towards the front. Francois Dell (personal communication), who has field experience with the language, informs me that the syllabic [v] is definitely a fricative.

The Representation of Tone

three contour tones) in citation form is not in itself sufficient evidence of five underlying even tones. Often citation tones are not good indicators of underlying tones. In the case of Changzhi, as we have demonstrated in §3.4.2.1, the citation contour (falling and rising) tones are derived from underlying even tones. One can well imagine that among the five surface even tones some are underlying contour tones. If so, we may expect that those even tones which are derived from underlying contour tones may have different sandhi behavior from those which are even on the surface as well as underlyingly. Unfortunately, no firm conclusion can be drawn for lack of sandhi data from languages with five surface even tones.

We are faced with the same paucity of data when we consider languages with more than two falling or rising tones. They are, again, very rare. Yip (1980:206) reports a language with five falling tones. This language, a Min dialect of Kienyang, has the following tonal inventory:

(141)	Level:	33			
	Rising:	35			
	Falling:	53 31	43 32	21	

There is no sandhi data which may help us decide whether the five falling tones are indeed falling underlyingly. In all likelihood the three falling tones 43, 32 and 21 are

The Representation of Tone

underlyingly even. If so, Kienyang makes nearly full use of the theoretically possible tonal contrasts: four even tones, two falling tones and one rising tone, as Yip points out. Kienyang can be explained away as a counterexample to the two-feature system that is at the core of the proposed theory.

Another dialect of Chinese, Xinzhou, has three falling tones: 53, 42 and 31. 42, however, does not occur in citation form, and is derived from 313. Xinzhou has the following tonal inventory (D.Z. Wen (1985)):²⁷

(142)	53	313	2
	31		

313 becomes 31 in phrase-final position, and 42 in phrase-initial position, hence Xinzhou has three surface falling tones: 53, 42 and 31. Assuming that 53 and 31 are underlyingly even, and 313 underlyingly falling, the phonetic realization of the underlying falling tone is contextually conditioned: as 42 phrase-initially and 31 phrase-finally. The difference between 42 and 31 is simply a surface phenomenon.

Yip (1980) proposes the addition of Woo's feature

27. The tone 313 is derived historically from the yin Even and Rising tones in classical Chinese. The sandhi behavior of 313 is in part determined by the historical source. Since it is not crucial for our purpose, I only cite the sandhi behavior of 313 derived from the ancient Rising tones.

The Representation of Tone

[modify] (see §2.4) to handle languages with genuinely more than four even tones or two falling or rising tones. Exactly how the feature figures in the geometry of tone can not be decided without adequate tone sandhi data. We can speculate that [modify] is a register feature which "modifies" the [-stiff] register. The two features [stiff] and [modify] define three registers:

(143)	H	M	L
stiff	+	-	-
modify		-	+

Recall that the feature [stiff] is phonetically implemented by the laryngeal articulator CT. It would be difficult to see which laryngeal articulator executes the feature [modify]. In other words, we do not have adequate data to decide on where the feature [modify] fits into the overall geometry of laryngeal features. I will not attempt to speculate on the possible configuration, and let the issue stand as a possible counterexample to the theory of tone that I develop in this thesis.

Chapter Four

Autosegmental Nature of Tone

In Chapter Three, I proposed the geometrical structure of tone, repeated below,

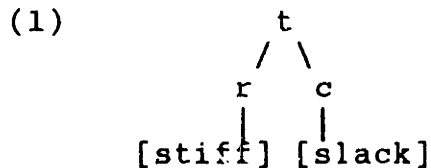

and showed how the tonal geometry accounts for tone sandhi effects that are observed in tone languages. In presenting arguments I made the assumption that tones are autosegmental. This is necessary because, as we have seen, tonal melodies undergo phonological processes independently of the segments on which they are realized. Since I claim that the geometry of tone is a substructure of the geometry of laryngeal features, particularly the geometry of the laryngeal features of nuclear vowels, the very fact of tonal assimilation is a testimony for the autosegmental treatment of tone. This can be illustrated by the register assimilation structure in (2):

Autosegmental Nature of Tone

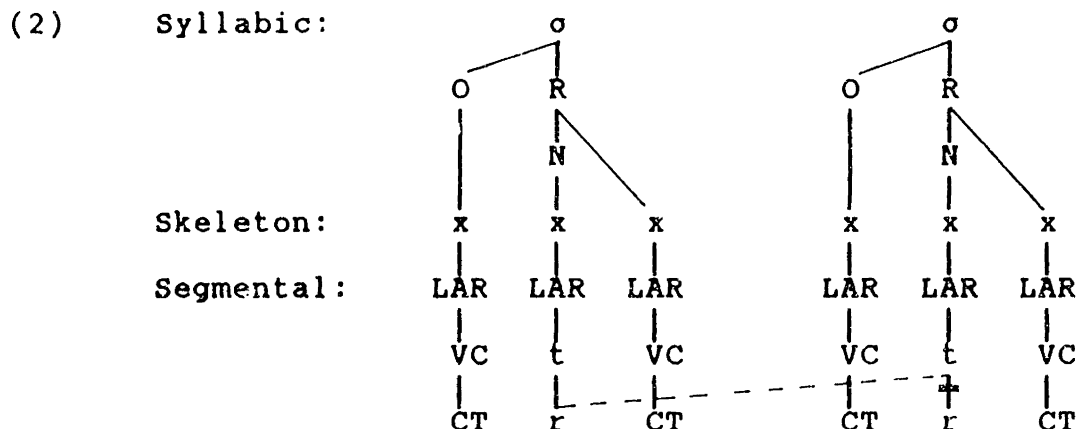

In (2), only relevant nodes are shown. LAR is the laryngeal node; VC is the vocal cords node, which is the geometrical structure of tone (i.e. the t node in (1)), and the CT node (i.e. the r node) is the articulator which executes the feature [stiff]. The CT node specifies voicing in consonants and pitch register in vowels. In the theory proposed here, the VC node and the t node are formally equivalent. For ease of discussion the VC nodes of nuclear vowels are represented as t nodes.

(2) is the structure for a bisyllabic phrase. We have seen sandhi processes of assimilation between the registers of two tones. If tones were segmental, as in (2), the r nodes (the CT) of the two nuclei would not be adjacent. Spreading the register of the first tone to the second tone crosses the CT nodes of the coda of the first syllable and the onset of the second syllable, as shown in (2). The structure violates a well-established condition on phonological processes: phonological rules affect elements

Autosegmental Nature of Tone

which are adjacent at some level of representation (Goldsmith (1976), Pulleyblank (1986), McCarthy (1989), Hewitt and Prince (1990)). If tones are autosegmental, the two tones in (2) will be adjacent on the tonal tier, and register spreading violates no known conditions:

(3) Syllabic Plane:

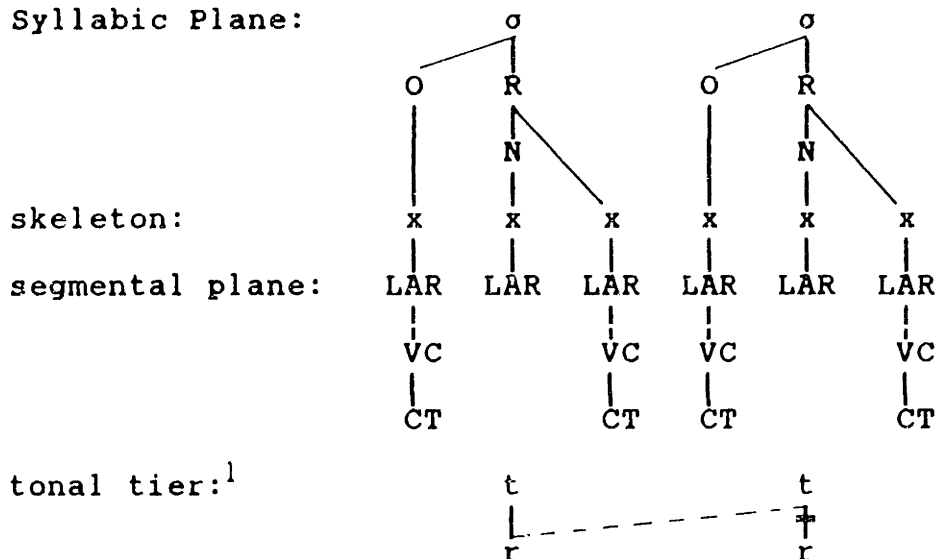

The *t* node merges into the laryngeal geometry of the nuclear segment when tone is segmentalized (see Chapter Five for discussion on the formal properties of representation and tone sandhi rules). The very fact of register assimilation as a type of tone sandhi supports an autosegmental representation of tone.

In this chapter, I argue further that tones are

1. In Chapter Five I argue that tones form an autosegmental tier on the syllabic plane. They do not form a separate, autosegmental plane. In the discussion to follow, I will represent tones as if they are an autosegmental plane. This is due solely to convenience of exposition.

Autosegmental Nature of Tone

autosegments. I will present three arguments. First, the lexicon may contain lexical items which are tonal, hence lacking in segmental anchors for tones (§4.1); second, tones remain when the segmental material of the syllables in which they are realized is deleted (§4.2) and third, tones may serve as a bridge for long-distance segmental assimilation (§4.3). For more arguments in favor of the autosegmental representation of tone, the reader is referred to the pioneering work of Yip (1980), which was done within the emerging framework of autosegmental phonology, and is a major contribution to our understanding of tonal phenomena.

4.1 Tonal Morphemes

4.1.1 Danyang Word Melodies

We have seen the Danyang data in §3.3.1.1. There I argued that the Danyang phrasal tone patterns can best be analyzed as involving the spreading of tones as melodic units. Danyang has a tonal inventory of six tones in citation form; including two short tones realized in syllables ending in the glottal stop. The tones are given in (4):

Autosegmental Nature of Tone

- (4)
- | | | |
|----|----|----------------------------|
| a. | 11 | lan "rotten" |
| b. | 33 | wang "net"; gao "high" |
| c. | 24 | fang "house"; dao "arrive" |
| d. | 55 | tu "earth" |
| e. | 3 | yi[?] "one" |
| f. | 4 | fu[?] "coat" |

Phrases with two, three and four syllables exhibit the tone patterns in (5):

(5)	Bisyllabic	Trisyllabic	Quadrisyllabic
a.	11-11	11-11-11	11-11-11-11
b.	42-11	42-11-11	42-11-11-11
c.	42-24	42-42-24	42-42-42-24
d.	33-33	33-33-33	33-33-33-33
e.	24-55	24-55-55	24-55-55-55
f.	55-55	55-55-55	55-55-55-55

Phrasal tone patterns like (5) can not be derived from the tones which make up the phrase. In §3.3.1.1 I posited six base tone melodies and argued that the tone patterns in (5) can be derived by spreading left to right the last tones of the base tone melodies. The base tone melodies, given below, must be stored in the lexicon:

- | | | | |
|-----|----|---------------------------|------------------------|
| (6) | a. | [L,l] | (base melody for (5a)) |
| | b. | [H,h ¹]-[L,l] | (base melody for (5b)) |
| | c. | [H,lh] | (base melody for (5c)) |
| | d. | [L,h] | (base melody for (5d)) |
| | e. | [H,lh]-[H,h] | (base melody for (5e)) |
| | f. | [H,h] | (base melody for (5f)) |

For details of the analysis, see §3.3.1.1.

The significance of the analysis of the Danyang tone spreading facts is two-fold. On the one hand, it

Autosegmental Nature of Tone

demonstrates that tones, especially contour tones, spread as melodic units, supporting theories which treat contour tones as such. On the other hand, the postulation of the base melodies in (6) as specified in the lexicon underscores an important property of autosegments, namely their phonological independence from the segments in which they are ultimately realized phonetically. To the extent that such postulation leads to a straightforward analysis of the Danyang tone spread data, we conclude that tones are autosegmental. A segmental view does not allow tones to be postulated independently of the segments.

4.1.2 Wenzhou Definitive Morpheme

Wenzhou classifiers exhibit a peculiar tonal change. The classifiers can be pronounced with the tone 323, regardless of their lexical tones. When this happens, they acquire the additional meaning of "this." The relevant data are given below (Zhengzhang (1964b:106), [l̥] represents voiceless [l]):

(7)	a.	kai 42	"one"
		kai 323	"this"
b.	pa 44	"group"	
	pa 323	"this group"	
c.	to 45	"one (flower)"	
	to 323	"this (flower)"	
d.	le 31	"some (people)"	
	l̥e 323	"these (people)"	

323 is a yin-registered (H-registered in our terms) tone. It is used with voiceless syllable initials, such as ko 323 "angle." The voiced initial liquid [l] in (7d) devoices as a result of the tone sandhi. The tonal alternation exemplified in (7) is morphologically motivated. Not only is there no discernible tonal environment which may trigger the sandhi phenomenon; but the added meaning of definitiveness can not be explained by a pure phonological derivation. To account for these facts, I assume that the lexicon of the Wenzhou dialect contains a definitive morpheme of the following form:

(8)	meaning:	definitive
	segmental:	none
	tonal:	[H, lh]

where the high rising tone [H, lh] surfaces as concave 323. To derive the sandhi facts, we first prefix the tonal morpheme to the stem.² The tone then spreads to the stem, delinking its lexical tone. The derivation of to 323 (cf. (7c)) is shown below (the tone 45 is represented as a high even tone [H, h]):

2. There is no fact of the matter whether the tonal morpheme is a suffix or prefix. Either assumption will serve to illustrate the existence of tonal morphemes; hence an argument for autosegmental representation of tone.

Autosegmental Nature of Tone

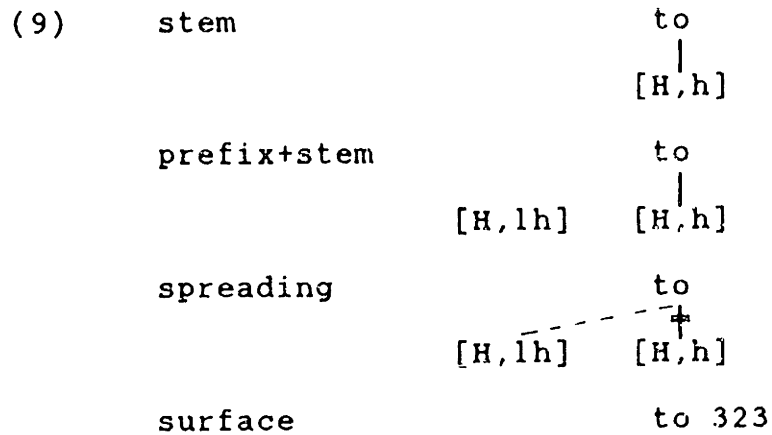

The existence of tonal morphemes such as the definitive in (8) supports the autosegmental representation of tone. The notion of tonal morpheme -- morphemes which consist of tones but lack segmental material is incompatible within a segmental theory of tone.

4.1.3 Cantonese Changed Tones

According to Yue-Hashimoto (1972:92), Cantonese has a total of eleven surface tones in citation form, shown in (10):

(10)	Ping	Shang	Qu	Ru
	(Even)	(Rising)	(Going)	(Entering)
Yin	53 or 55	35	44	5, 4
Yang	21 or 22	24	33	3

The Ru tones are short tones realized on syllables ending in /p t k/. The short tones are derived from regular

Autosegmental Nature of Tone

tones. Yue-Hashimoto (1972:92) identifies 5 with 55; 4 with 44 and 3 with 33. The same view is expressed in Kao (1971) and Yip (1980). No arguments are given for these identifications. We will see shortly that there is evidence that 5 is derived from 35, rather than 55.

In addition to the tones in (10), there is the so-called changed tone, which surfaces phonetically as 35 and 55, depending on the phonological environment. The changed tones are derived, which we will represent with a star, as *35 and *55. Words which surface in one of the changed tones acquire new meaning. Chao (1947:35) characterizes it as "that familiar thing one often speaks of." According to Yue-Hashimoto (1972:94), the changed tone "usually carries with it some specialized meaning -- familiarity seems to be the dominant note." Relevant data are given in (11) (from Yue-Hashimoto (1972:94), except (11g), which is taken from Kao (1971:99). Transcription is in Pinyin, except the endings in square brackets):

- | | | |
|------|--------------------------|----------|
| (11) | a. yu 21 > yu *35 | "fish" |
| | b. li 24 > li *35 | "plum" |
| | c. duan 33 > duan *35 | "satin" |
| | d. ji 44 > ji *35 | "trick" |
| | e. zei[k] 3 > zei[k] *35 | "thief" |
| | f. ta[p] 4 > ta[p] *35 | "pagoda" |
| | g. san 53 > san *55 | "dress" |

I am not able to find data showing 5>*35 or 35>*35 alternation in Yue-Hashimoto (1972) or Yip (1980). Kao

Autosegmental Nature of Tone

(1971:111) says that "neither syllables ending in stops having the primary tone 5: nor syllables ending in other than stops having the primary tone 35: are affected by the changed tone." Kao uses 5: and 35: for 5 and 35 respectively. See also Chao (1947). The fact that 5 and 35 behave in the same fashion as far as the changed tone phenomenon is concerned supports the view that 5 is actually a variant of 35, rather than 55, as assumed by Yue-Hashimoto (1972) (see §3.2.3 for further discussion). The tonal alternations are summarized below:

$$(12) \quad 53/55 \rightarrow *55 \quad \left[\begin{array}{c} 21/22 \\ 24 \\ 44 (4) \\ 33 (3) \end{array} \right] \rightarrow *35$$

Note that tones 53 and 55 (21 and 22) are in free variation.

Yip (1980:62-63) states the changed tone phenomenon as follows:

If a tone begins at a high level (i.e., level 5), then it becomes a high level tone. If it begins at any lower level, then it becomes a rising tone ending at level 5.

To account for the alternations observed in (12), Yip proposes a morpheme which consists of a floating high tone with no segmental material, a possibility only when tones

are viewed as autosegments.³ I will call the morpheme "familiarity morpheme," denoted by t_f . To derive the changed tones, the familiarity morpheme is suffixed to the stem; the high tone then spreads leftward, as illustrated in (13):

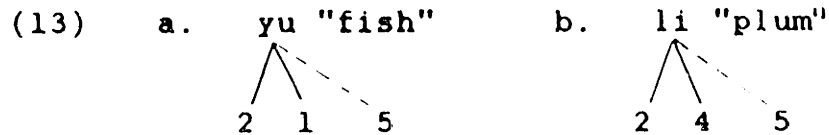

In (13), 5 is the floating tone, which spreads onto the stem yu "fish" (13a) or li "plum" (13b).

But the numbers are phonetic manifestation of underlying tones. If we consider the underlying representations of 21, 24 and the high floating tone 5, the derivation is not as straightforward as (13) indicates. In Yip's (1980) theory (see §2.5, Chapter Two), the three morphemes may be represented as follows:

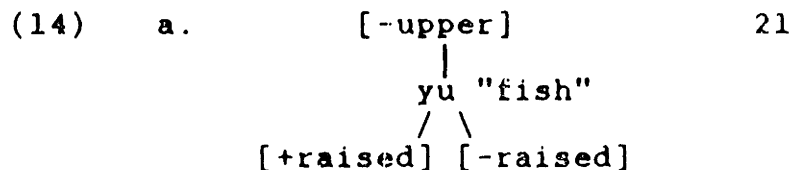

3. Chao (1956:1) describes the changed tone as a "non-syllabic and non-segmental suffix." Yip's analysis takes advantage of the theoretical devices available in the emerging framework of autosegmental phonology.

Autosegmental Nature of Tone

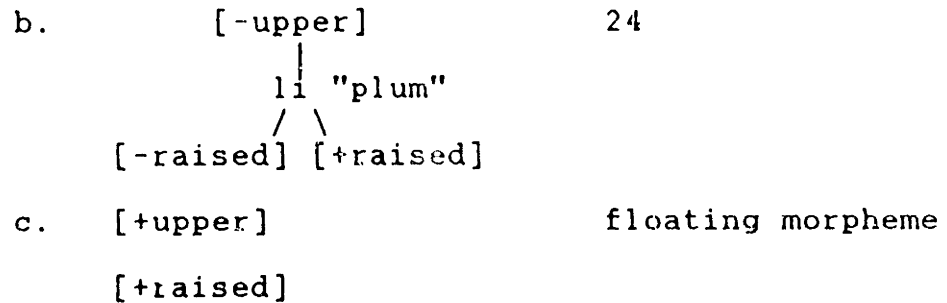

(14c) is the representation of the familiarity morpheme, which lacks segmental material. Suffixing the tonal morpheme to 21 and 24, we get the following forms:

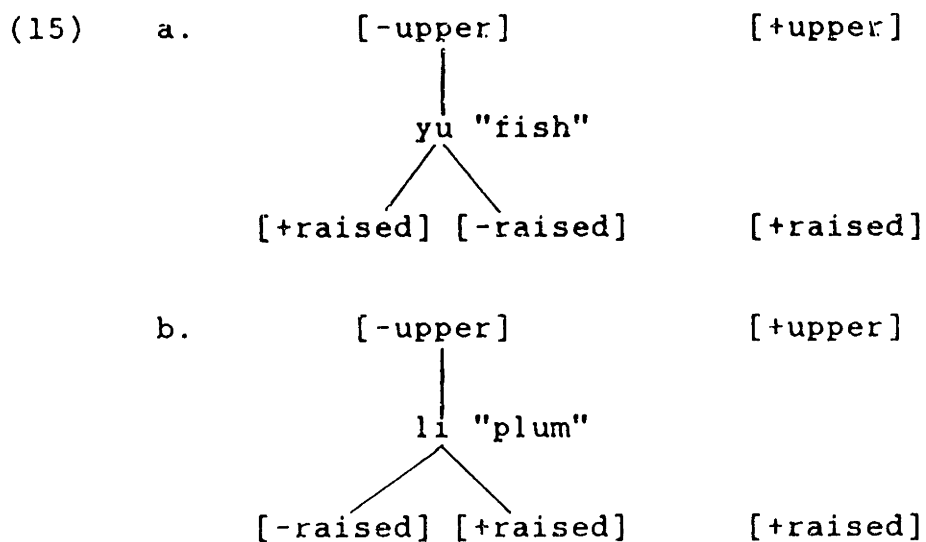

To derive the changed tone *35 from 21 and 24, [+upper] and [+raised] of the familiarity morpheme must spread simultaneously; and [+raised] of the original tones need to be delinked, as shown in (16):

Autosegmental Nature of Tone

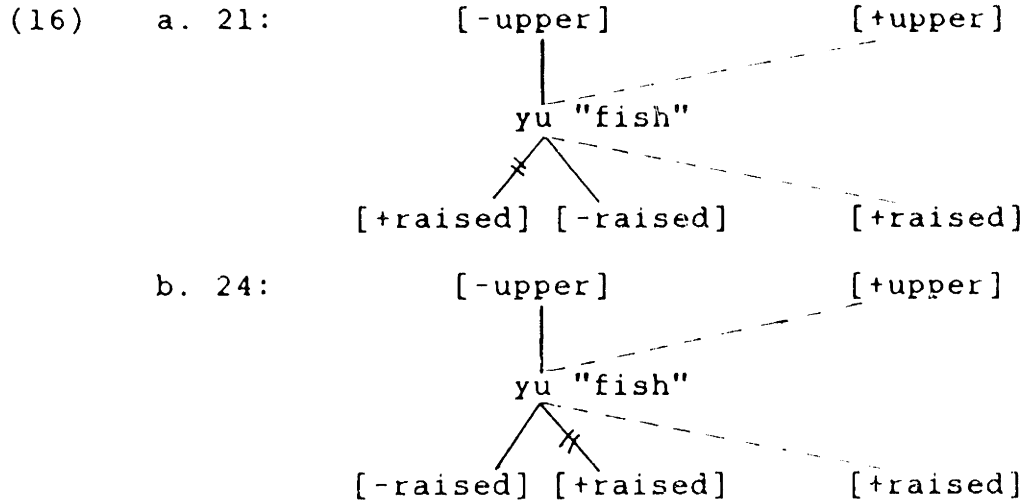

Technicalities aside,⁴ Yip's analysis of the Cantonese changed tone is a convincing argument in favor of autosegmental representation of tones. The analysis I propose below bears close resemblance to Yip's; the difference is theory-internal.

I assume that the tones in Cantonese have the structures in (17):

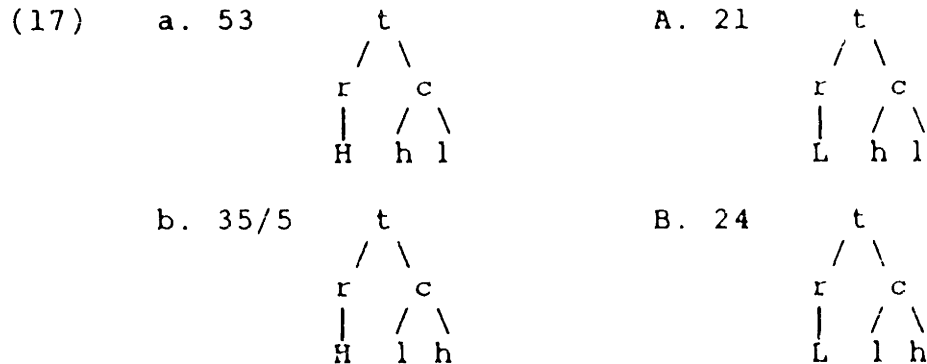

4. Note that 21 and 22 are in free variation. Yip (1980:357) assumes 22 to be the underlying tone, and 21 derived. This avoids the technical difficulty facing her analysis.

Autosegmental Nature of Tone

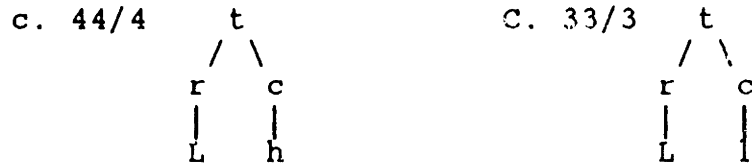

Underlyingly, 53, 35 and 5 are H-registered tones, and the rest are L-registered. Syllable-initial consonants do not affect the pitch register (Yue-Hashimoto (1972:102-109)). The reason for treating the even tone 44 as the surface manifestation of the underlyingly L-registered tone (17c) is due to the fact that 44 has the same sandhi behavior as the rest of the L-registered tones: its changed tone alternant is *35 (see (11d)).⁵

There is a general sandhi process in Cantonese whereby the high falling tone 53 surfaces as high even 55 when preceding 53 or 5 (Kao (1971) and Yue-Hashimoto (1972)). The 53>55 sandhi is exemplified below (Kao (1971:84)):

5. The tones which Yue-Hashimoto represents as 44 and 33 are given the values of 33 and 22 respectively by Kao and Yuan et al. Kao (1971:93) posits six "tonal phonemes", as in (i):

- | | | | |
|-----|--------------|-------|-----------|
| (i) | a. 53 (55,5) | b. 35 | c. 33 (3) |
| | A. 21 | B. 23 | C. 22 (2) |

Yuan et al (1960:208) gives the following tone inventory:

- | | | | | |
|------|-------------|-------|-------|---------|
| (ii) | a. 55 or 53 | b. 35 | c. 33 | d. 5,35 |
| | A. 21 or 11 | B. 13 | C. 22 | D. 2 |

It must be emphasized that the numbers are relative values of auditory impression. It is hardly surprising that different authors give different values to the same tones.

- (18) a. tog kwa > tog kwa "winter melon"
 53 53 > 55 53
 b. kej tok > kej tok "Christ"
 53 5 > 55 5

This can be accounted for by the contour simplification rule of the form in (19):⁶

(19) Contour Simplification

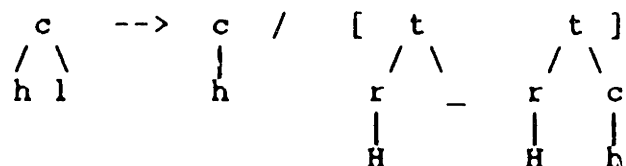

In (19) the c-node of second tone dominates h (that is, [-slack]). Only 53, 55, and 5 meet the condition of the simplification rule.

The treatment of 35/5 is based on two considerations: first, unlike other tones, 35 and 5 do not have a changed tone variant (Chao (1947), Kao (1971)); second, they condition the same sandhi change on the preceding tone when the segmental material of the syllable with 35 or 5 is deleted, see §4.2.1. Note that 35 does not cause the 53>55 sandhi. This is so because the condition for the contour simplification rule (19) is not met: the rising contour

6. Zong (1964) raises serious doubt that 55 is derived from 53. He argues that 55 and 53 are contrastive tones in Cantonese.

begins with l under the c node. The short tone 5 is derived from 35 by the rule formulated below:

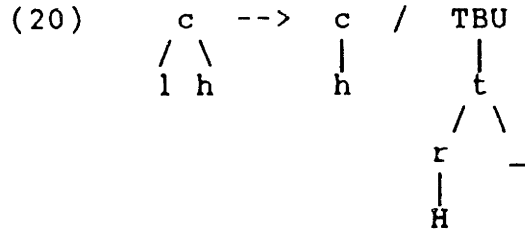

Condition: TBU ends in /p t k/

This rule derives 5 from 35 just in case 35 is realized on a syllable which ends in /p t k/. The short tone 5, however, does not condition the 53>55 sandhi (cf. (18b)). This indicates that rule (20), which derives 5 from 35, applies before the contour simplification rule (19). The derivation of the two cases in (18) is as follows:

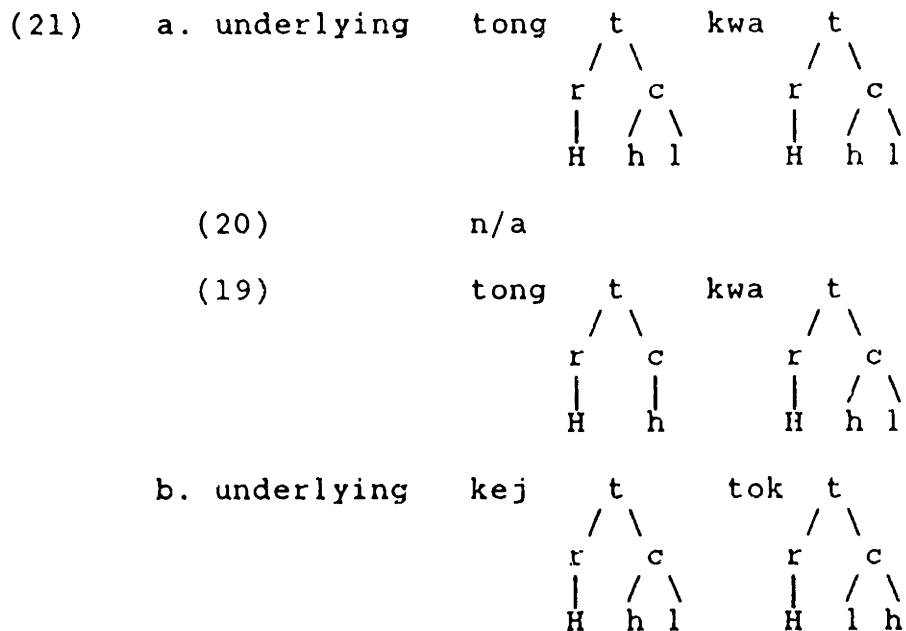

Autosegmental Nature of Tone

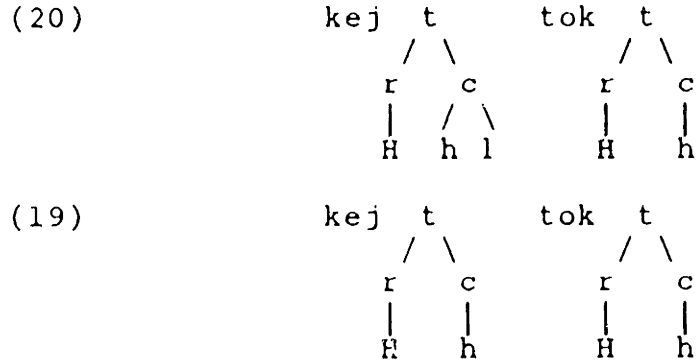

Following Yip (1980), I posit a morpheme of familiarity which lacks segmental material. It consists of the high even tone, as shown in (22):

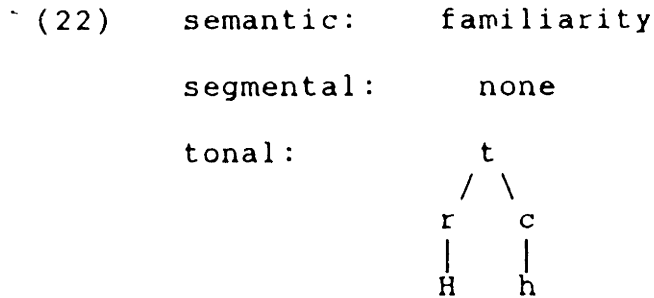

When suffixed to a syllable with the high falling tone 53, it conditions the 53>55 change (see (11g)). The rising contour of 35 is created by inserting l ([+slack]) to the c node. The insertion rule is given in (23):

(23) Contour Formation

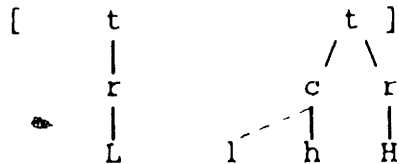

The contour formation rule inserts [+slack] to the c node of

the familiarity morpheme when it follows a L-registered tone, creating a rising contour. The requirement that the register of the preceding tone be L will become apparent as we go along (see the derivation in (25)). (23) derives 35 from the underlying structure in (22), just in case the preceding tone is L-registered.

In my analysis, the changed tones *55 and *35 are derived by two separate rules: *55 by (19), which is a general sandhi rule of Cantonese;⁷ and *35 by the rules in (23) and (24), which spreads the tonal morpheme to the stem if the register of its lexical tone is L-registered:

7. Chao (1947:26) says that the changed tone *55 with the meaning of familiarity is not the same as 55 derived from the underlying tone 53, because the former "is associated with a special kind of function and meaning, irrespective of tonal environment." Chao's observation is correct in that words with the changed tone *55 in san *55 "dress" (< san 53) (cf. (11g)) have the meaning of familiarity. By contrast, 55 in kej 55 tok 5 (> kej 53 tok 5) (cf. (18)), which is derived from 53 by the sandhi rule Contour Simplification (19), does not have the added meaning of familiarity. But the meaning of familiarity comes from the morphemic tonal suffix, which is present in san *55, but not in kej 55. The phonological condition for contour simplification is met in both cases. Given the analysis being proposed here, the changed tone *55 is derived by rule (19), since t_f , being H-registered, conditions the 53>55 sandhi change just like any other H-registered tones. There is no need to view the changed tone *55 in san *55 (< san 53) any differently from 55 in kej 55 (< kej 53). Both are derived by rule (19). The difference is the trigger: the presence versus the absence of the familiarity morpheme.

Autosegmental Nature of Tone

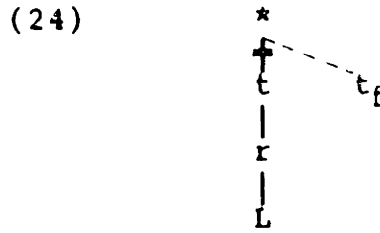

where t_f is the tonal morpheme. The derivation of li 24 "plum" and san 53 "dress" is shown below (only tones are shown; * is tone bearing unit):

(25) Suffixation of t_f :

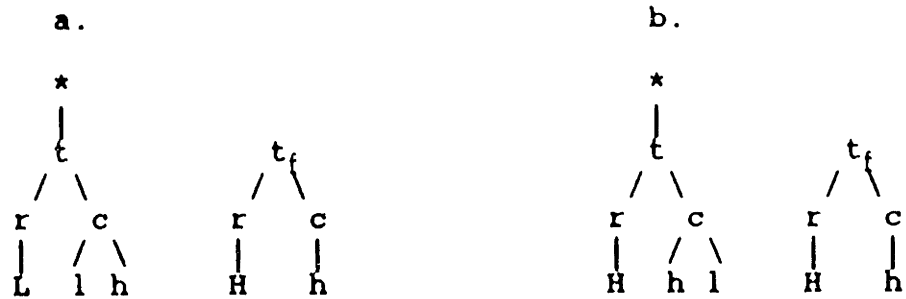

Contour Formation (23):

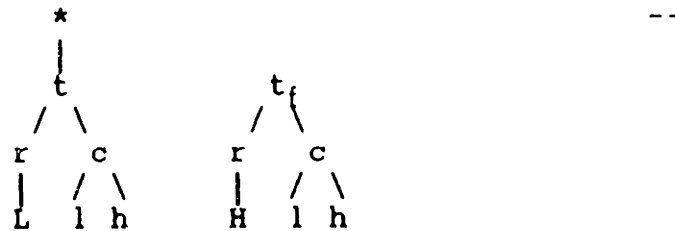

Spreading (24):

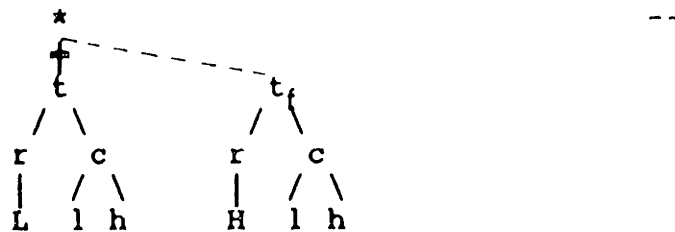

Autosegmental Nature of Tone

Contour Simplification (19):

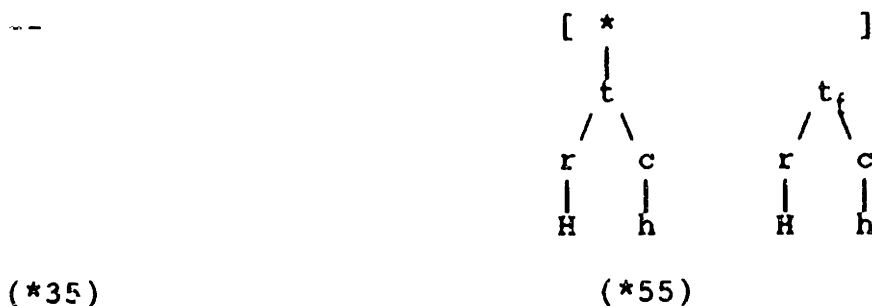

The unassociated tones do not surface. Note that in (25b), the contour formation rule (23) and the spreading rule (25) are not applicable because the register of the preceding tone is H. Both rules require that the register of the preceding tone be L. Because of this, t_f is left behind to eventually condition the simplification rule (19).

The existence of a tone-only morpheme in Cantonese supports the view that tones are autosegmental.

4.1.4 Prefixes in Jiading Miao

Jiading Miao is a Miao dialect spoken in a region by the name Jiading in the province of Guizhou in southwest China. This dialect has a number of prefixes that perform various semantic and syntactic functions. The prefixes are grouped roughly into two major categories in terms of the stems to which they are affixed (V is any vowel) (all data are taken from S.-Y. Yue (1979)):

(26) a. nominal marker:

qV 13; qV 31; kV 13; kV 55; pV 31; ɔkV 13;
ɔkV 55; lV 31

b. verbal marker:

tV 13; shV 13

Among the nominal markers, there are some semantic restrictions on the stems to which they are affixed. For instance, kV 55 is prefixed to stem nouns which designate insects, and ɔkV 13 and ɔkV 55 are prefixed to stem nouns which designate birds. When prefixed to the stem, V invariably surfaces as the vowel of the stem-initial syllable. Relevant data are given below:

(27)

a. qV 13 animate objects, their body parts, ailment

qi 13	pli 43	"wild cat"
qo 13	ho 13	"head"
qe 13	mple 55	"tongue"
qu 13	plu 31	"rat"
qõ 13	põ 22	"rash"
qæ 13	plæ 13 mõ 31	"wasp sting"

b. qV 31 same as (a)

qw 31	ɰw 43	"the small one"
qε 31	shε 24	"the new one"
qw 31	khw 55	"the skinny one (people)"
qo 31	nzo 22	"the skinny one (animal)"

c. kV 13 same as (a)

ki 13	ki 43	"skin rash"
ki 13	ki 22	"bottom"
kõ 13	ɔkõ 13	"valley"

Autosegmental Nature of Tone

d. kV 55 insects

kə̃ 55 tə̃ 13	"ticks"
ko 55 nsho 13	"flea"

e. ɔkV 13; ɔkV 55 birds

ɔki 13 si 43	"yellow-feather bird"
ɔkə 13 sə 43	"wild chicken"
ɔkw 55 tɔw 24	"?"

f. lV 31 ordinal number

li 31 i 24	"first"
læ 31 pæ 24	"third"
lo 31 plo 24	"fourth"
lu 31 tɔu 55	"nineth"

g. tV 13 short events

ti 13 si 13	"to squeeze through"
tɛ 13 zɛ 24	"to cut vegetables"
tə 13 sə 43	"to throw rocks"
tɛ 13 tɛ 22	"to take off one's hat"

h. shV 13 continuous events

shu 13 iu 22 su 24	"to pull"
shə 13 tə 55	"to dance"
shu 13 vu 22	"to ferment fertilizer"

reciprocal events

shu 13 tɔu 22	"to meet"
shə 13 tə 55	"to fight (dogs)"
shə 13 ntə 55	"to fight (people)"

Descriptively, the prefixes in Jiading Miao are all monosyllabic (i.e. of the form CV) and take up the vowels of the stem-initial syllables. This means that they can not be represented with a fully specified vowel as nucleus. Since the prefixes have their own tones, the tones will therefore lack segmental anchors prior to acquiring the vowels from

the stems to which they are attached. A segmental approach to tone, which requires a vowel (or sonorant) for a tone, will therefore fail to characterize the prefixes of Jiading Miao. Such prefixes pose no problems for an autosegmental approach to tone. The tones are represented on a separate plane from the segmental material. The Jiading prefixes support the view that tones are autosegmental.

To account for the facts in (27), I assume that each of the prefixes is represented in the lexicon with a syllabic template, a tone, an onset segment but no nuclear segment. The structure of qV 13 illustrates:

(28) The Structure of qV 13

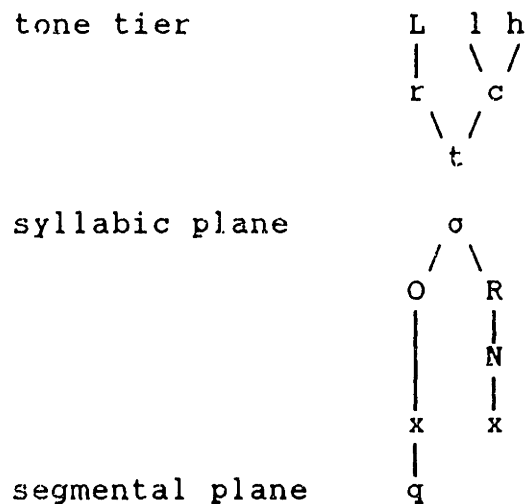

Suppose that in Jiading Miao vowels and consonants are segregated (McCarthy (1979, 1981, 1989), Prince (1987)). We can then derive the patterns in (27) by spreading the stem-initial vowels on the V plane. The form qu 13 plu 31 "rat"

Autosegmental Nature of Tone

(cf. (26a)) is derived in the following fashion (syllabic structure and tone structure are omitted):⁸

8. In Marantz's (1982) theory, a reduplication analysis starts out with a CV prefix with C and tone pre-specified. The derivation of qu 13 plu 31 is as follows:

(i) Prefix + Stem

CV 13 + CCV 31
| | | |
q plu

Copy Stem Melodies

plu

CV 13 + CCV 31
| | | |
q plu

Association

plu
|
CV 13 + CCV 31
| | | |
q plu

Surface

qu 13 plu 31

See Marantz (1982) for details of the theoretical apparatus behind the derivation in (i).

Autosegmental Nature of Tone

(29)	Prefix + Stem	q	13		p	l	31
		x	x	+	x	x	x
							u
	Vowel Spread	q	13		p	l	31
		x	x	+	x	x	x
							u
	Surface	qu	13		plu	31	

A reduplication analysis of the Jiading facts is also possible, but the implication remains the same: tones must be represented autosegmentally, rather than segmentally.

4.2 Tones under Segmental Deletion

4.2.1 Cantonese

In the analysis proposed in §4.1.3 we posited a floating tonal morpheme (t_f) which has the meaning of familiarity. This morpheme is suffixed to the word stem. The changed tone *55 is generated by a general sandhi rule which changes the high falling tone 53 to high even 55. The changed tone *35 is derived by the feature-inserting rule (23) and the spreading rule (24), which spreads t_f to a L-registered tone. This accounts for the fact that 5 and 35, which are phonetic variants of the high rising tone [H, !h] (17b), do not have a changed tone alternant (Kao (1971:111)). The analysis of the changed tone phenomenon

Autosegmental Nature of Tone

based on the tonal morpheme of familiarity (t_f) is supported by another class of tone sandhi facts of Cantonese reported in Bai (1989). Similar facts are discussed in Kao (1971), Yue-Hashimoto (1972) and Yip (1980). My data come from W.-R. Bai (1989).

The changed tone *35 is derived after the suffixation of the tonal morpheme t_f , which affects the meaning of the stem. *35 may come from another source. Certain words in Cantonese with the surface tones 35 and 5 may be deleted in fast speech, but the tones remain, and surface on the preceding syllable. The resultant string acquires no new meaning, since it does not involve any affixation of a new morpheme. The relevant segmental deletion data are given in (30) (/A/ is mid vowel):⁹

9. Bai (1989) postulates the following tone inventory of Cantonese:

- (i) a. high tones: 55, 53, 35, 5
- b. low tones: 21, 23, 33, 22, 3, 2

Autosegmental Nature of Tone

(30) a. Deletion of tso 35, perfective particle

mai tso > mai	"have bought"
23 35 *35	
iau tso > iau	"have painted"
21 35 *35	
pin tso > pin	"have changed"
33 35 *35	
tsou tso > tsou	"have made"
22 35 *35	
t'ek tso > t'ek	"have kicked"
3 35 *35	
sok tso > sok	"have been cooked"
2 35 *35	

b. Deletion of iAt 5 'one'

iAt t'Am iAt t'Am	"puddle by puddle"
5 23 5 23	
> iAt t'am t'am	
5 *35 23	
iAt hɔg iAt hɔg	"line by line"
5 21 5 21	
> iAt hɔg hɔg	
5 *35 21	
iAt ts'yn iAt ts'yn	"bunch by bunch"
5 33 5 33	
> iAt ts'yn ts'yn	
5 *35 33	
iAt tam iAt tam	"mouthful by mouthful"
5 22 5 22	
> iAt tam tam	
5 *35 22	

Autosegmental Nature of Tone

iAt tat iAt tat	"patch by patch"
5 3 5 3	

> iAt tat tat
5 *35 3

iAt tip iAt tip	"plate by plate"
5 2 5 2	

> iAt tip tip
5 *35 2

Other words which exhibit the same sandhi phenomenon include tak 5, hai 35 and tou 35. According to Bai (1989:114), two conditions must be met for the sandhi process exemplified in (30) to take place: first, the tones undergoing the sandhi are low; they are 21, 23, 33, 22, 3 and 2. The high tones 53/55, 35 and 5 are not affected. The data in (30) do not contain examples of 53, 35 or 5 undergoing the change. Second, the deleted syllable carries the high tone 35 or 5. The facts in (30) can be readily explained, as shown in the derivation of mai *35 "bought" and iAt 5 tam *35 tam 22 "mouthful by mouthful":

Autosegmental Nature of Tone

(31) Underlying:

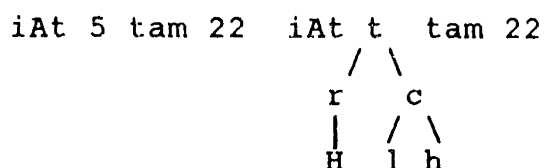
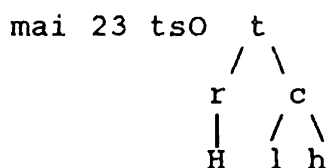

Segmental Deletion:

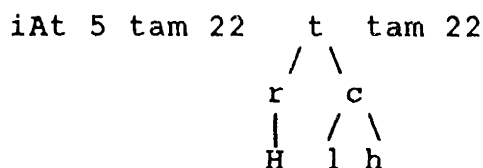
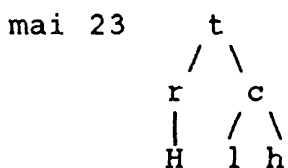

(20) not applicable

(19) not applicable

(23) not applicable

Spreading (24)

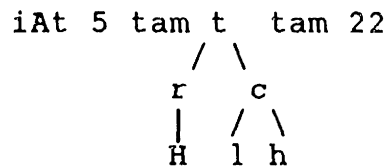
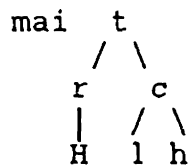

(mai *35)

(iAt 5 tam *35 tam 22)

Note that rule (20) does not apply to the string after the segments of the syllable have been deleted. The rule requires that the tone bearing unit (here, the syllabic rime) end in /p t k/. The deleted segments, iAt, would have conditioned the 35>5 sandhi change.

The deletion of segments plays a crucial part in the derivation of the facts in (30). Tones survive segmental deletion. This is not possible if tones are segmental, but the expected result if tones are autosegmental.

4.2.2 Fangjie Languages

Another piece of evidence in favor of autosegmental representation of tone comes from a kind of game language which Chao (1931) calls fangjie languages (Chao (1931), Yip (1982), Li (1985), Lin (1988), and Bao (1990); see also §5.2, Chapter Five). Fangjie languages are constructed by the philological method of fangjie, i.e. "reverse cut." Long before the introduction of romanization schemes the fangjie method was frequently used by philologists and classicists alike in pre-modern China to specify the pronunciation of a novel character by means of two familiar ones. The method can best be illustrated by the following hypothetical example:

(32) ma 55 < mo 53 pa 55

In (32), the two syllables to the right of the arrow mo 53 and pa 55 are assumed to be familiar characters (syllables) which are used to specify the unknown character ma 55. The unknown character is pronounced with the initial of the first syllable and the rime of the second syllable, including its tone.

Descriptively, fangjie languages are created by splitting a given syllable from a source language into two parts, the initial and the final. The first segment (including the zero segment) is the initial; the rest

constitutes the final. The initial is combined with a new final, and the final is combined with a new initial, generating a bisyllabic word as shown in (33):

(33) ma 55 > mo 53 pa 55

In (33) the source syllable ma 55 is split into the initial m and the final a 55. The initial m is combined with the new final o 53, and the final a 55 is combined with the new initial p, yielding the bisyllabic word mo 53 pa 55. Fanqie language formation is the reverse process of fanqie as a philological tool. The fanqie word mo 53 pa 55 could be used to specify the pronunciation of the source word ma 55 (cf. (32) and (33)). Bao (1990) argues that the derivation of fanqie languages involves the following two steps:

- (34) a. Reduplication (cf. Steriade (1988))
 b. Substitution of onset and rime

Now consider the tone patterns of a fanqie language based on the dialect of Kunshan, spoken in the Jiangsu Province. Following Chao (1931), I will call it Mo-pa.¹⁰ The data are given in (35):

(35) a. pã 33 > po 33-vã 33 "country"
 b. ts'I 4 > ts'o 4-zI 4 "seven"

10. Chao (1931) names a fanqie language after its word for ma 'mother.' 'Mo-pa' is derived from ma, hence the name for this fanqie language based on the dialect of Kunshan.

Autosegmental Nature of Tone

Both syllables of the Mo-pa words (to the right of the arrow) have the tone of the source syllable (to the left of the arrow). Note that in the first syllable in (35a), the source segmental rime [a] is deleted and replaced with [o], but the source tone remains. Similarly, in (35b), the deletion of the source segmental rime [I] does not affect the source tone. If tones are segmental, deleting the vowel will also delete the tone, and the tone pattern of Mo-pa exemplified in (35) can not be explained. By contrast, if tones are autosegmental, deleting a segment will not affect the tone, since segments and tones are on different planes. The derivation of po 33 vã 33 from pã 33 is shown in (36):

(36)	Source syllable:		
	tone plane	33	"country"
	segmental plane	pã	
	Reduplication:	33	33
		pã	pã
	Substitution:	33	33
		po	vã

Substitution takes place on the segmental plane, hence the tones are not affected by the operation (see Bao (1990)).

The fanqie language facts support the view that tones are autosegmental.

4.3 The Bridge Effect

In nonlinear phonology, assimilation is viewed as spreading of the assimilating feature(s), which is subject to the locality condition (see Steriade (1982), Archangeli (1985), Clements (1985a), Myers (1987), McCarthy (1989), Hewitt and Prince (1990), among other works). This condition states that elements affected by phonological rules, among them rules of assimilation, must be adjacent at some level of representation. In a multiplanar representation, it is possible for an element to assimilate into a nonadjacent element in one plane via some operation on a separate plane. I will call this phenomenon the bridge effect. To illustrate, consider the structure in (37):

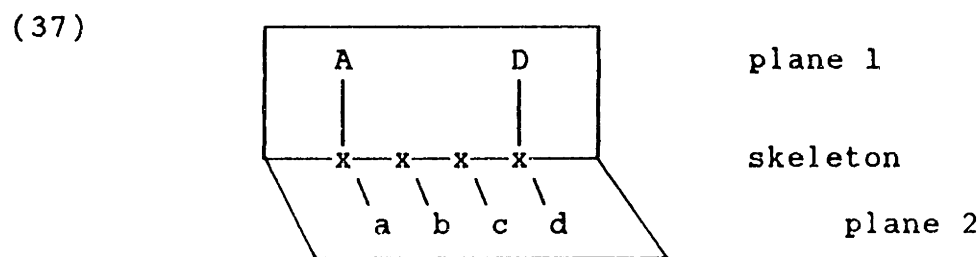

On plane 1, A and D are adjacent; on plane 2, a and d are not adjacent. The intervening b and c prevent a from spreading to d on plane 2. On plane 1, A and D are adjacent, therefore A is able to spread to D. Now suppose that A spreads to D, yielding the structure in (38):

(38)

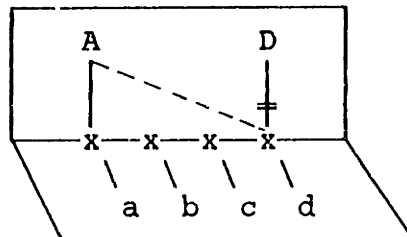

plane 1

skeleton

plane 2

where D is delinked. Let's further suppose that there is a rule which links an x-slot to a on plane 2 if it is associated with A on plane 1. Then the structure (38) will result in the structure in (39):

(39)

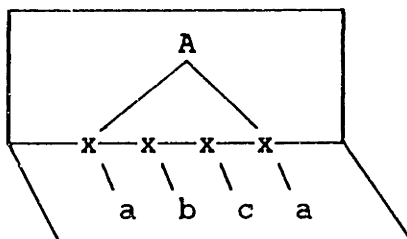

plane 1

skeleton

plane 2

Hypothetically, a in effect spreads to the position formerly occupied by d on plane 2 via the spreading of A on plane 1. Bridge effects are possible only in a multi-planar (or multi-tiered) structure. In a linear representation a can not spread to d without violating the locality condition.

Wuyi furnishes data that exhibit the bridge effect of tonal assimilation. Wuyi has eight surface tones in citation form, as follows (all Wuyi data are taken from G.-T. Fu (1984)):

Autosegmental Nature of Tone

(40) yin register tones	yang register tones
a. 24 sa "raw"	A 213 za "tailor"
b. 55 pu "beach"; p'u "common"	B. 13 bu "part"
c. 53 t'ia "supreme"	C. 31 dia "big"
d. 5 foʔ "duplicate"	D. <u>212</u> voʔ "cloth"

In our terms, the yin register tones are [+stiff]; the yang register tones are [-stiff]. In (40), the H-registered tones occur with voiceless obstruents in syllable-initial position (the left column in (40)); and the yang register tones occur with voiced obstruents (the right column). There is a strict correlation between consonant voicing and tonal register.¹¹

We will consider the tone patterns of nominal phrases involving the tones (40a,A,c,C). Relevant data are as follows:

(41)	a. 24-24 > 24-53	
	øie sa	"mister"
	kau t'og	"transportation"
	?li ?lu	"spider"
	t'ie kog	"Heavenly Lord"

11. Wuyi has two series of sonorants, as shown below:

(i)	?m	?n	?l	?ɲ	?ŋ
(ii)	ɦm	ɦn	ɦl	ɦɲ	ɦŋ

The sonorants in (i) are glottalized; and those in (ii) are voiced. The yin tones occur with the sonorants in (i); the yang tones occur with the sonorants in (ii).

Autosegmental Nature of Tone

b. 213-24 > 213-53

dʒiaŋ kaŋ	"The Yangtze River"
ɦɲie kɿ	"New Year's Rice Cake"
dzua pa	"tea mug"
ɦaŋ tɕiəu	Hangzhou

c. 24-213 > 24-53

fog ʔliag (< ɦliag)	"cool"
ɦua ʔog (< ɦoŋ)	a fruit
ɕie ʔu (< ɦu)	"West Lake"
kuag ʔioŋ (< ɦioŋ)	"glorious"

d. 213-213 > 213-31

ɦu dʒiŋ	a Chinese musical instrument
ɦuag ɦuo	The Yellow River
ɦnoŋ ɦmiŋ	"peasant"
die dzuo	"investigate"

e. 24-53 > 24-53

sa ʔi	"business"
kau tɕia	"intersection"
ɕiəu tɕiŋ	"correct"
fəŋ fu	"ask"

f. 213-53 > 213-53

ɦliŋ ɕia	"neighbor"
ɦnəŋ kau	"able"
doŋ tɕiŋ	"brass mirror"
biŋ tɕiŋ	"even"

g. 24-31 > 24-53

sa ʔmiŋ (< ɦmiŋ)	"life"
ɕy ʔɲye (< ɦɲye)	"school"
sa fuo (< vuo)	"raw meal"
ɦua ʔiaŋ (< ɦiaŋ)	"pattern"

h. 213-31 > 213-31

ɦmua da	"hemp bag"
ɔʒiaŋ ʒiəu	"longevity"
dʒiaŋ dt	"robber"
bi ɦmuo	"leather hat"

Autosegmental Nature of Tone

The tone patterns are summarized below (the horizontal axis is the second tone of a bisyllabic phrase; the vertical axis is the first tone):¹²

(42)	I	II	III	IV
	24	213	53	31
24	24-53	24-53	24-53	24-53
213	213-53	213-31	213-53	213-31

Assuming the tones 24, 213, 53 and 31 to have the structures in (43),¹³

12. Other tones undergo tone sandhi in bisyllabic phrases as well. They are as follows:

citation tone	sandhi	environment
24, 213	55	before 55, 13, 5, <u>212</u>
53	55	before all tones
5, <u>212</u>	5	before all tones
55, 13, 31	11	before all tones

Except (42), none of the tones undergo sandhi in phrase-final position. For the analysis of the above sandhi data, see §5.3, Chapter Five.

13. The concave tone 213 is underlyingly a low rising tone, as it has basically the same tone sandhi behavior as the high rising tone 24. We need the contour formation rule (i) to derive the contour:

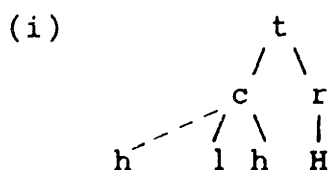

Since (i) is not crucial for the purpose of our discussion, I will simply use 213.

Autosegmental Nature of Tone

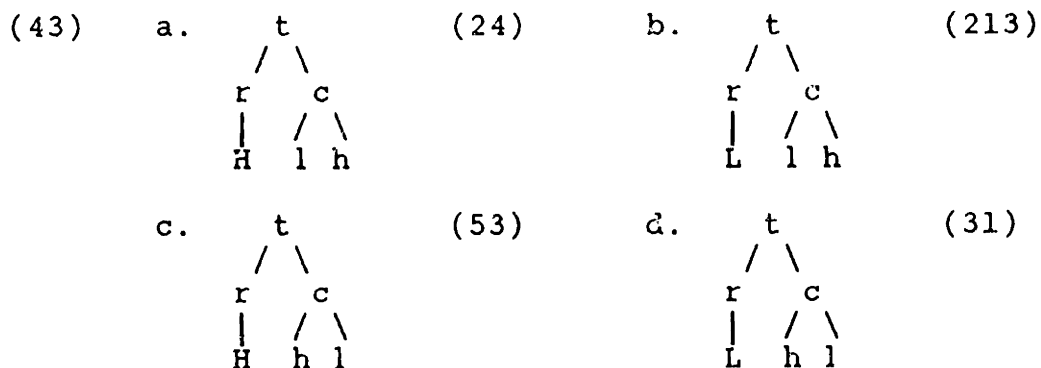

we can make the following observations from the tone patterns in (42):

- (44) a. Rising tones become falling phrase-finally (Columns I and II)
- b. Given (a), the low falling tone is raised following a high tone (Column II and IV)

As a result of raising, the voiced syllable-initial consonants devoice (cf. (41c,g)). The sandhi facts in (42) can be accounted for in terms of the two rules in (45):

- (45) a. Contour Metathesis

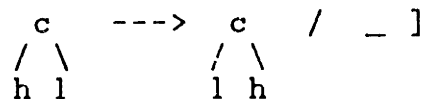

- b. Register Spreading

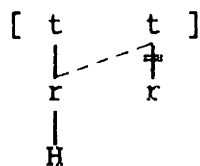

As noted earlier, there is a strict correlation between tonal register and the voicing qualities of the syllable-

Autosegmental Nature of Tone

initial segments. Due to this onset-register harmony, the registers of the tones are predictable from the syllable-initial segments. If the segment is voiceless, the register is H; if voiced, it is L. This is expressed in the following two statements:¹⁴

- (46) a. If the syllable-initial segment is [+stiff],
the tone is [+stiff];
- b. If the syllable-initial segment is [-stiff],
the tone is [-stiff].

In Chapter Five I will argue for a set of tone adjustment rules which produces the same effect as the statements in (46). For now I assume that in Wuyi lexical items are associated with the tones in accordance with the

14. Apparently, we can not express the onset-tone harmony as a result of assimilatory spreading, since tones and syllable-initial segments are on different planes:

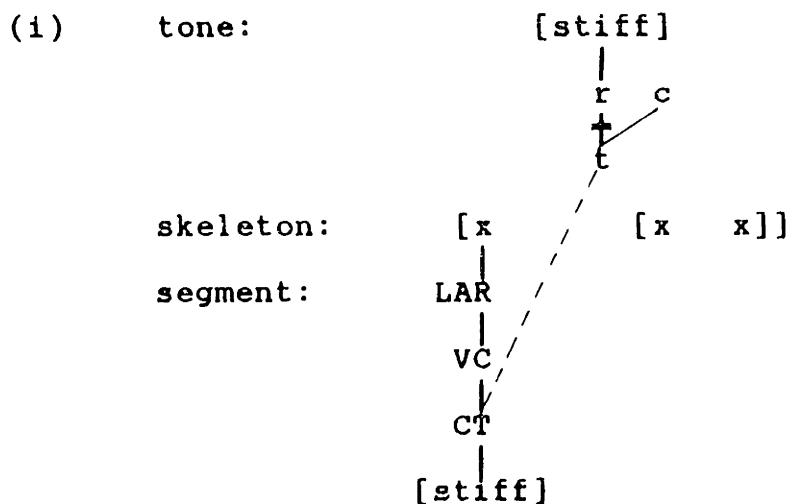

Autosegmental spreading involves tiers on the same plane. The current conception of planar representation precludes the possibility of trans-planar spreading such as (i).

Autosegmental Nature of Tone

statements in (46). In other words the representation to which sandhi rules apply shows the effect of onset-register harmony. A sample derivation follows:

(47) Underlying ɕie ŋu "West Lake" (= (41c))

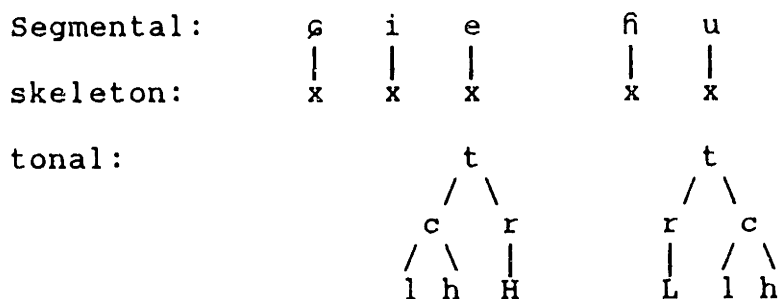

Metathesis (45a)

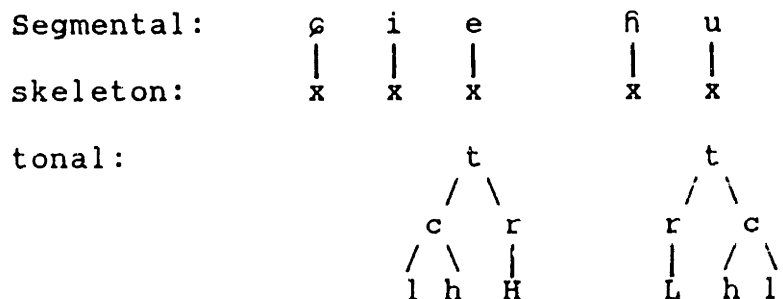

Register Spreading (45b)

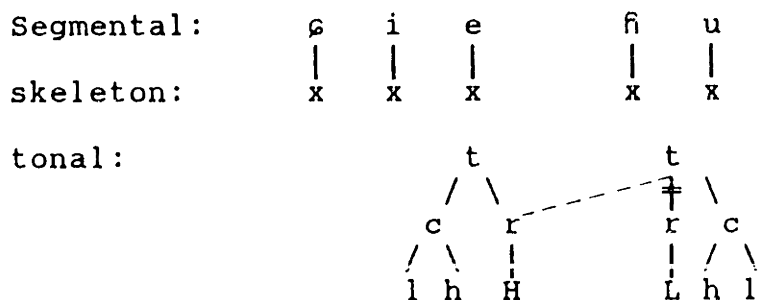

(24-53)

At this stage of the derivation, after all the tone sandhi rules have applied, tones are segmentalized -- namely they

Autosegmental Nature of Tone

become part of the segments with which they are associated. Segmentalization merges the tone melodies with the laryngeal nodes of the nuclear segments (vowels and other syllabic segments). After segmentalization of tone, the structure in (48) is derived from the output in (47) (only the laryngeal node is shown; rt is the root node):

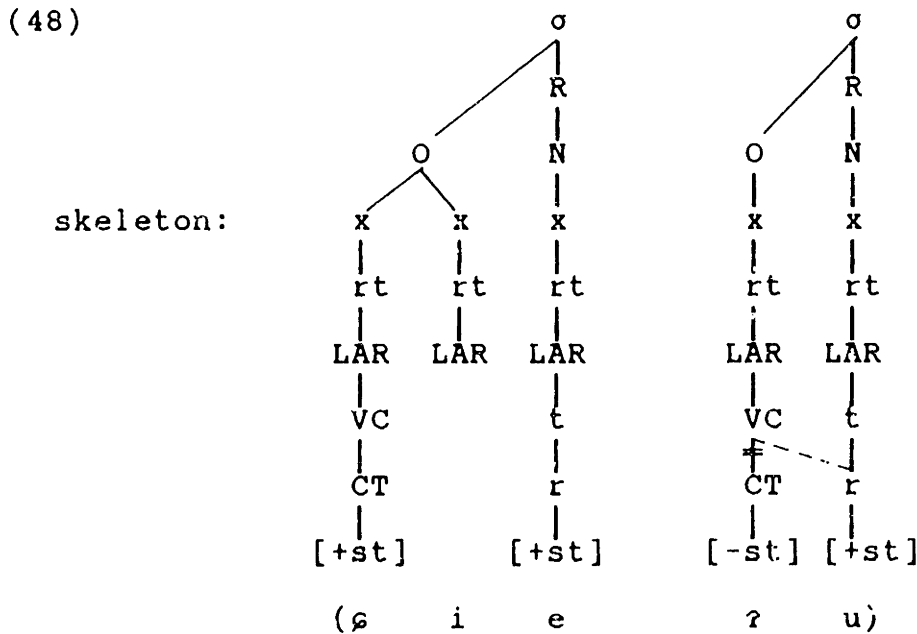

Note that the t node is equivalent to the VC node; and the r node to the CT node. Syllable-initial devoicing results from spreading the r node of the tone to the preceding VC node, as shown in (48). Devoicing is a late stage assimilatory process.

The analysis of the sandhi-induced devoicing in Wuyi supports the view that tones are autosegmental. As can be seen clearly from the structure in (48), onset devoicing is

Autosegmental Nature of Tone

ultimately caused by the initial segment of the phrase-initial syllable: since it is voiceless, i.e. [+stiff], the tone is H-registered (also [+stiff]); the H register then spreads to the following L-registered tone, causing devoicing. Thus, tones serve as a bridge for voicing assimilation between two onsets of a bisyllabic phrase.

The bridge effect is impossible to characterize if tones are segmental. A segmental analysis not only fails to account for register spreading; it also fails to account for onset assimilation exemplified in (41c,g). In both cases lines are crossed:

(49) a. Register Assimilation

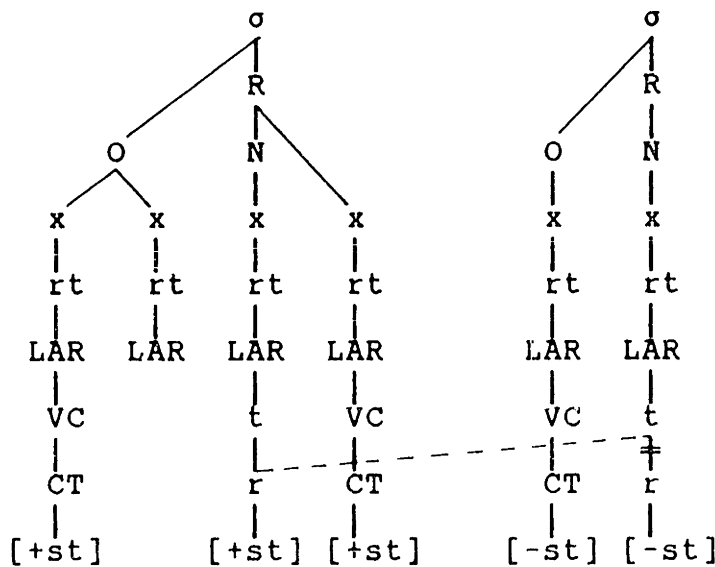

Autosegmental Nature of Tone

b. Onset Assimilation

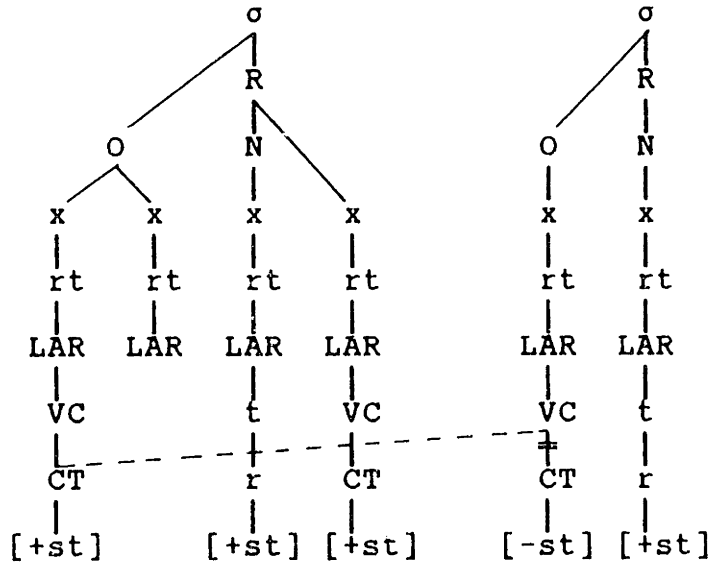

The bridge effect of register assimilation provides evidence in favor of an autosegmental treatment of tone.

Chapter Five

Tone in Phonological Representation

5.1 The Dual Nature of Tone

The relationship between tone and other elements of phonological representation has been controversial in early generative study of the topic. The controversy centers around the representation of tone (Hyman (1975)). On the one hand, the segmentalists maintain that tones are a property of vowels (Woo (1967)); while the suprasegmentalists claim that tones are a property of suprasegmental entities such as syllables (Wang (1967)). Regarding the relationship between tonal features and segmental features, Wang (1967:95) writes,

In languages like Chinese the tone features are sometimes relevant for the initial consonant, sometimes for the nuclear vowel, and sometimes for the final consonant in various phonological rules. If we were to add a column of tone features to a phonological matrix of segmental features, then it becomes arbitrary where precisely to insert this column. Furthermore, segmental features are usually not relevant in the various types of tone sandhi; that is to say, the interaction of tones in a sequence is independent of the nature of the segments which occur with the tones.

Wang's remark underscores the relative independence between tone features and segmental features on the one hand; and between tone sandhi processes and segmental processes on the

Tone in Phonological Representation

other. Independence notwithstanding, it remains true that tones are phonetically realized on segments that bear phonological features of tone. In tone languages tonal and segmental features together provide the articulatory instructions for the production of segments, particularly vowels.

The dual character of tone is amply demonstrated in the discussion on tonal geometry (Chapter Three) and the autosegmental properties of tone (Chapter Four). I have shown that the geometry of tone is a substructure of the feature geometry of the vowel, as shown in (1) (the Supralaryngeal node is suppressed for clarity):

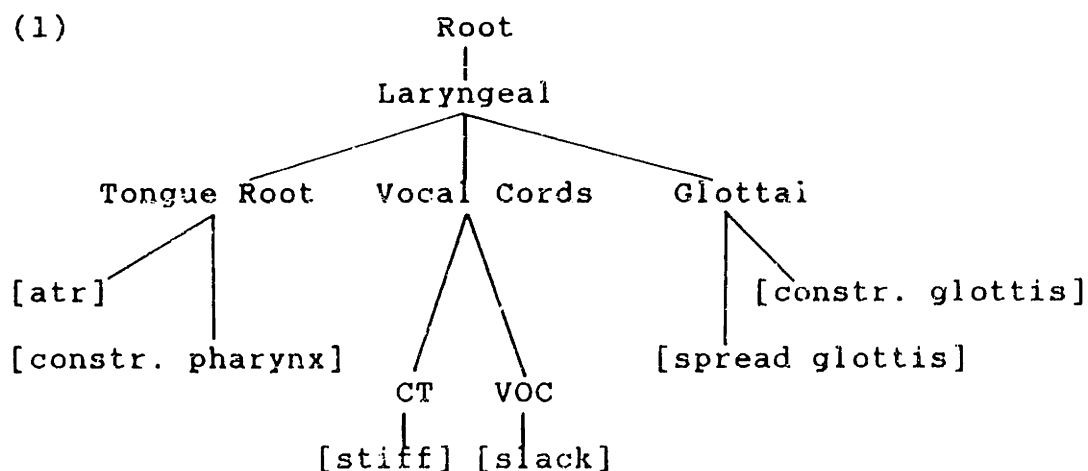

The claim is that tones are phonetically realized on the Vocal Cords node of a syllable nucleus segment. This accounts for the segmental aspect of tone.

In autosegmental phonology, the simple, linear representation of early generative phonology (cf. *SPE*) is

Tone in Phonological Representation

replaced by multiple levels in parallel to each other.

Consider the schematic representation in (2) (P=phoneme; T=tone):

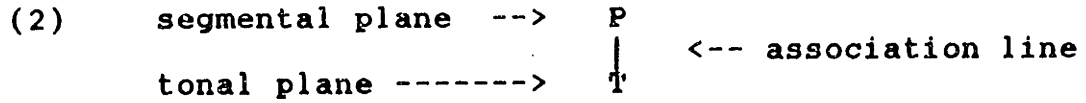

The structure in (2) is abstracted from some of the important works in the framework of autosegmental phonology, such as Goldsmith (1976a,b), Yip (1980), Halle and Vergnaud (1982), and Pulleyblank (1986). It consists of two parallel levels labeled as the segmental plane and the tonal plane.¹ Elements on each plane are linked by means of the formal device "association line." The phonological independence between tones and segments is captured formally in terms of plane separation. Rules which operate on one plane may leave elements on the other plane unaffected. Association lines formalize phonetic realization: tones are realized on the phonemes with which they are linked by means of the association lines. In the structure (2), T is realized on P.

Plane separation, though liberating tones from vowels, fails to capture suprasegmental properties of tone as traditionally understood (Wang (1967), Lehiste (1970), Hyman

1. Archangeli (1985:336) defines the terms plane and tier as follows: "Tier refers to plane-internal sequences of matrices parallel to the core skeleton. Plane refers to the entire melody (or structure) anchored in the core skeleton." My use of the terms essentially follows Archangeli's.

Tone in Phonological Representation

(1975)). In a different form the structure in (2) represents the segmentalist's view of tone, which holds that tone is a feature of vowels. Suprasegmental notions such as rime or syllable are not encoded in a way which is relevant for tone association. The issue which fueled the early segmentalist versus suprasegmentalist controversy still remains. The formal characterization of the relationship between tones and segments must be dealt with.

In autosegmental studies of tone, however, the issue has been avoided altogether. Tones are said to be associated with tone-bearing units (TBUs). The term "tone-bearing unit" is a term of convenience, and has no formal status in autosegmental representation. In early work on tones within the autosegmental framework, it is assumed, either explicitly or implicitly, that TBUs are syllables or vowels, which are usually interchangeable. For example, Halle and Vergnaud (1982), in discussing Williams' (1971) Tone Mapping Rule, are noncommittal as to what elements may serve as tone-bearing units. This can be seen clearly in their addition to Williams' formulation of the Tone Mapping Rule:

(3)

- i. It maps from left to right a sequence of tones onto a sequence of syllables.
- ii. It assigns one tone per syllable, until it runs out of tones.
- iii. then, it assigns the last tone that was specified to the remaining untoned syllables on the right,...
- iv. until it encounters the next syllable to the right belonging to a morpheme with specified tone.
- v. If the procedure above runs out of vowels (syllabic elements or syllables), more than one tone may be assigned to the last vowel only if the grammar of the language includes a stipulation to that effect.

(v) is Halle and Vergnaud's addition. In Halle and Vergnaud's view, tones are assigned to vowels, syllabic elements or syllables. More recently Pulleyblank (1986:19) explicitly states that "there will be virtually no discussion of what constitutes a tone-bearing unit." The formal treatment of the notion of tone-bearing unit is overlooked.²

Given that tones are autosegments, the question arises

2. The theoretical indifference for the segmentalist versus suprasegmentalist controversy can be traced much earlier. Hyman (1975) writes,

It appears that the syllable approach and the segment approach are readily translatable into each other.... We can assume that this is due to the fact that syllables are defined in terms of segments and, as a result, it is always possible to avoid talking about syllables and talk instead of the segments which define them. (p. 215)

Tone in Phonological Representation

whether it is possible to map tones onto suprasegmental entities such as rimes or syllables. If tones are conceived to form a separate plane, then such a mapping possibility is ruled out in current autosegmental theory, in which the x-skeleton binds the various autosegmental planes. We may state the relation between planes and x-skeleton as follows:³

- (4) Autosegmental planes may link to x-skeletons only

The structure in (2) is ill-formed if the association line is interpreted as linking the tone T directly to the phoneme P. The structure in (5) is well-formed:

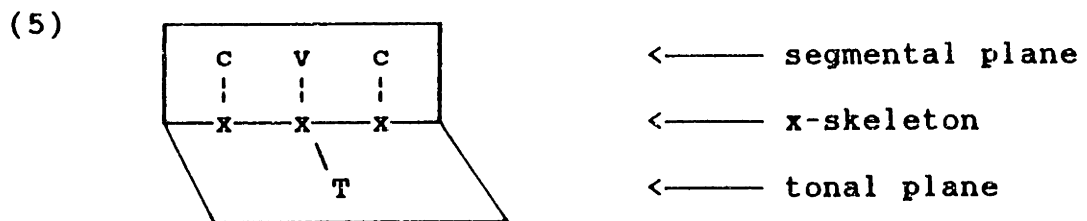

In this structure, the x-skeleton mediates the tone T and the vowel v. The condition (4) is satisfied.

With the introduction of feature geometry theory, the

3. The condition in (4) is essentially a paraphrase of Pulleyblank's (1986) stipulation in (i):

- (i) Autosegmental tiers can only link to slots in the skeletal tier

Pulleyblank's use of the term "tier" is equivalent to "plane."

Tone in Phonological Representation

representation of phonological form is enriched greatly. In addition to the conception of tone as forming an independent autosegmental plane, as in the structure (5), it is possible to see tone as forming an autosegmental tier within the segmental plane or the syllabic plane. With respect to tone, there are three ways in which the condition (4) may be satisfied. They are shown in (6) (Rt=root node, O=onset, N=nucleus, R=rime):⁴

(6) a. Tone as Plane

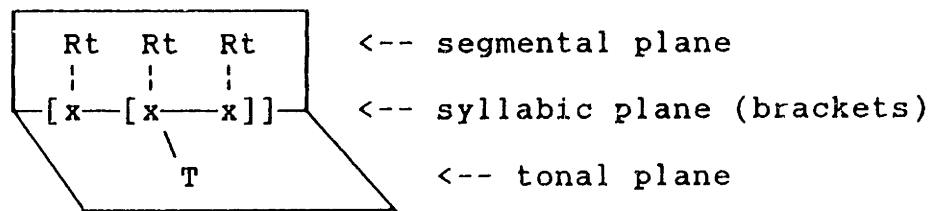

4. The segments are assumed to be on a single plane. The discussion of tone is independent of the issues of v/c-segregation. For discussion, see Prince (1987), and references cited there.

Tone in Phonological Representation

b. Tone as Tier in Segmental Plane

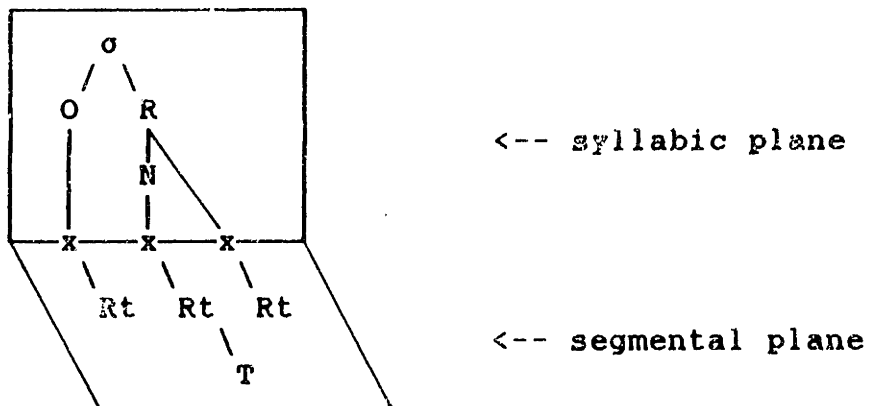

c. Tone as Tier in Syllabic Plane

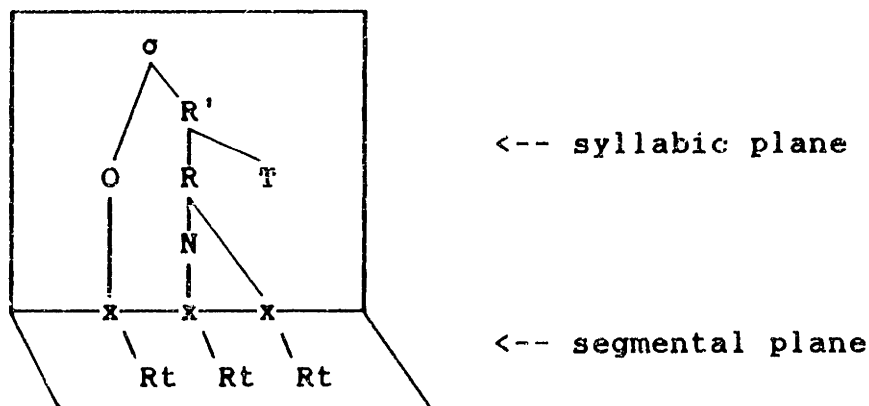

(6a) is equivalent to (5), in which the tone node T forms a separate plane, and is associated with the x-slot of the syllabic nucleus. The condition in (4) is satisfied because the tonal plane, like the segmental and syllabic planes, is anchored on the x-skeleton. This is the structure assumed in various autosegmental studies on tone. In structures (6b,c), where tones do not form a separate plane, the condition (4) is satisfied vacuously. The structure (6b) is proposed by Archangeli and Pulleyblank (1989), in which

Tone in Phonological Representation

tone is a tier of the root node on the segmental plane. Bao (1990) proposes (6c), in which tone is represented as a tier on the syllabic plane. Note that O necessarily precedes R in time because the x-slot dominated by O precedes the x-slot(s) dominated by R. There is no temporal ordering relation between T and other syllabic constituents, since T is not associated with the x-skeleton, which comprises timing slots. However, T is indirectly ordered before O.

The three structures make different empirical predictions concerning the behavior of tone. Note that in all three structures tone sandhi can take place independently of the segments since tones form an autosegmental tier in (6b,c), and an autosegmental plane in (6a). It has long been observed that phonological operations on segments do not affect tones, a phenomenon known as tone stability. As an underlying representation, the structure (6b) fails to account for tone stability, since tone is dominated by the root node of a segment, phonological operations on the root node necessarily affect the tone. Tone stability is a direct consequence of both (6a) and (6c).

The structures in (6a,c) make different empirical predictions with respect to what I call constituent operation, as opposed to string operation. String operation is a phonological process which involves strings of segments

Tone in Phonological Representation

regardless of their constituent structure. Constituent operation, by contrast, is a phonological process which involves an entire constituent, its structural and segmental makeup. Consider two hypothetical rules of deletion, shown in (7):

(7) a. S-deletion

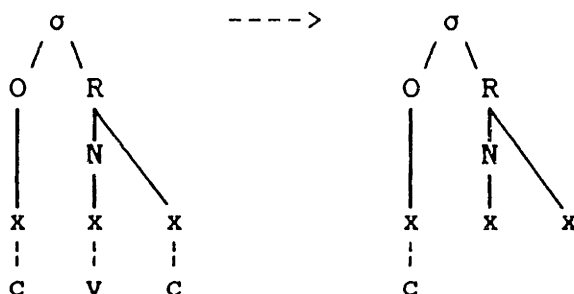

b. C-deletion

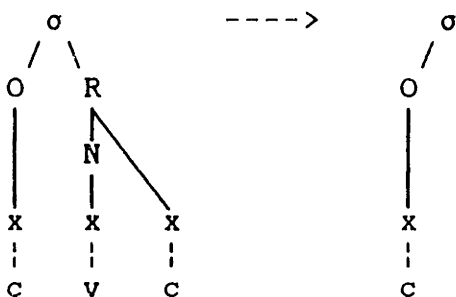

The process captured in S-deletion (7a) is a string operation, which deletes the segments on the segmental plane which are associated with the x-slots dominated by the R node; the syllabic structure is left intact. The process captured in C-deletion (7b) is a constituent operation which deletes the entire rime constituent -- its structure and segmental content. The two rules yield different sandhi

Tone in Phonological Representation

effects when applied to the structures in (6), as shown in (8):

(8) a. Tone in Tonal Plane

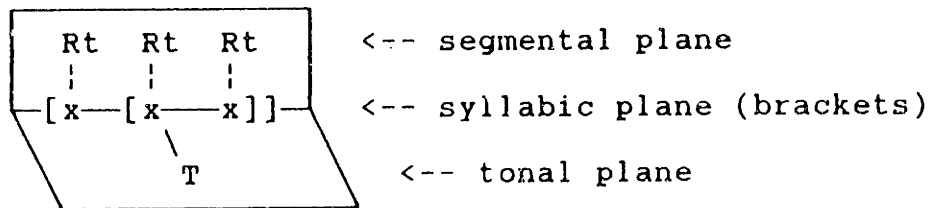

I. S-Deletion (7a)

II. C-Deletion (7b)

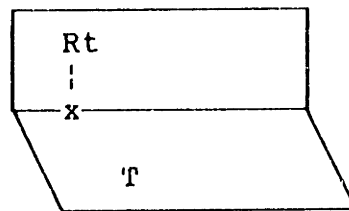
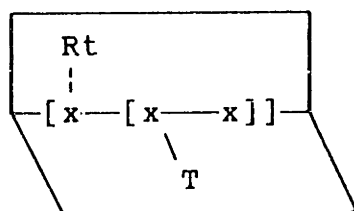

b. Tone as Tier in Segmental Plane

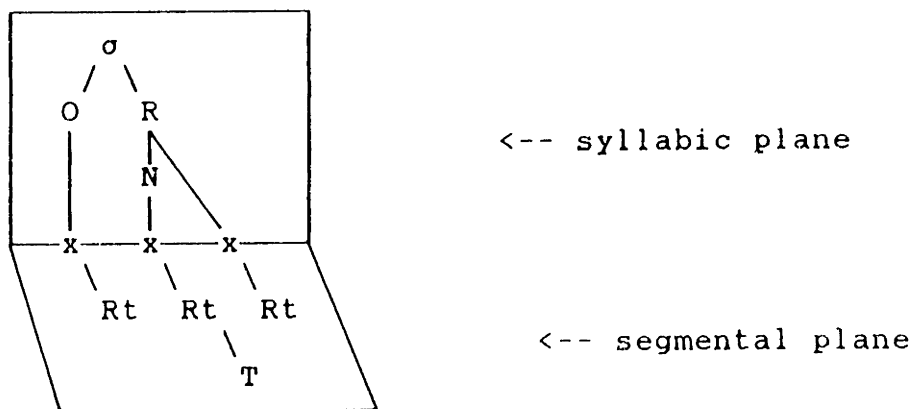

Tone in Phonological Representation

I. S-Deletion (7a)

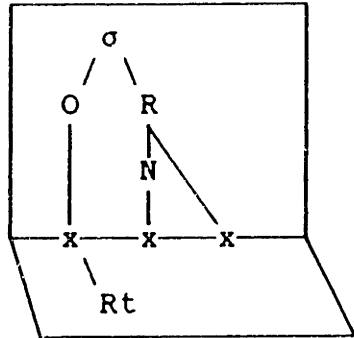

II. C-Deletion (7b)

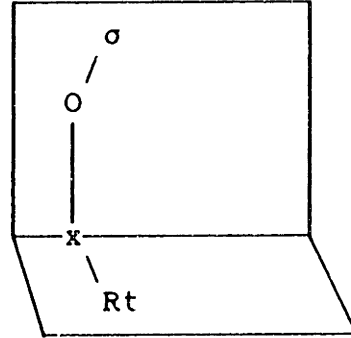

c. Tone as Tier in Syllabic Plane

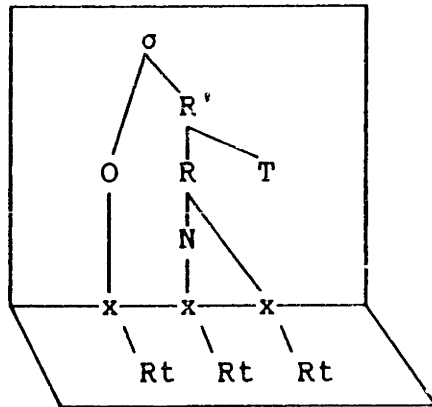

<-- syllabic plane

<-- segmental plane

I. S-Deletion (7a)

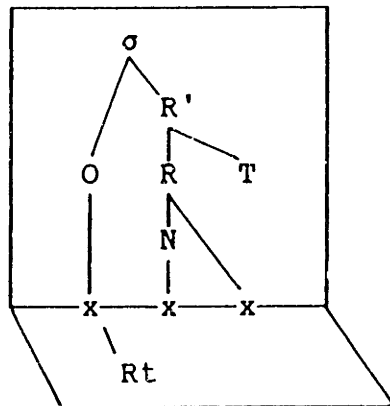

II. C-Deletion (7b)

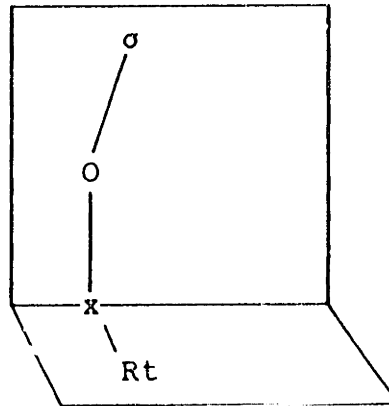

III. C-Deletion (7b)

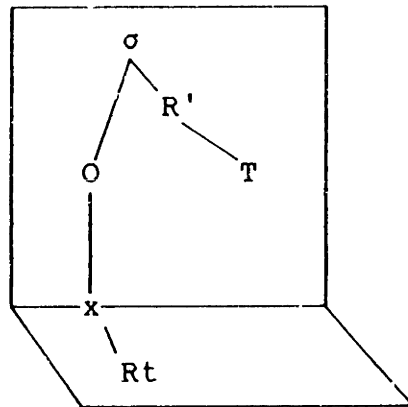

The derivations in (8a) show that if tones form an autosegmental plane separate from the segments and syllabic constituents, it is theoretically possible for tones to remain on their plane in both types of deletion processes. If tones are represented as constituent nodes of the root nodes which define tone bearing segments, they will be deleted along with the segments in both types of operation (cf. (8b)). If, however, tones are represented as an autosegmental tier on the syllabic plane, tones will remain under S-deletion (cf. (8cI)), but will be deleted under C-deletion (cf. (8cII)). In (8cII), C-deletion is assumed to apply to the R' constituent, and T is deleted as well; in (8cIII), it applies to the R node, T survives deletion. Tone stability is structure-dependent. Since the structure in (6b) fails to account for tone stability, we can dismiss it as the underlying representation of toned syllables. The structure in (6a) accounts for tone stability maximally in

Tone in Phonological Representation

the sense that tones are expected to be stable under all kinds of phonological processes (except those that expressly affect tones). The structure in (6c), however, makes an interesting prediction concerning the structure-dependency of tone stability. The prediction is stated in (9):

(9) Given the structure

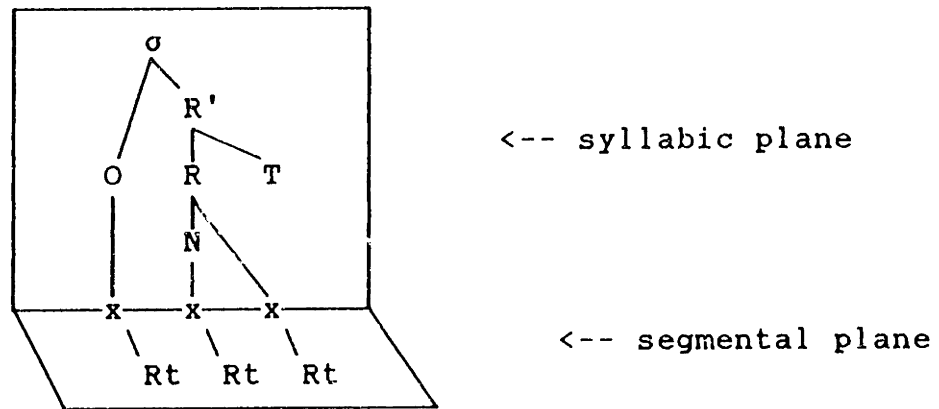

and a structure-sensitive phonological rule P,

T is stable if and only if P involves sub-R' elements.

This prediction is not made by the structure in (6a). This is where the empirical difference lies between the two structures (i.e. (6a,c)). I will show in the following section that the prediction (9) is confirmed in game languages called fanqie languages.

5.2 Structure-Dependency of Tone Stability ⁵

Crucial evidence in support of the structure-dependency of tone stability comes from game languages called variously fanqie languages or secret languages (Chao (1931), Yip (1982), P. J.-K. Li (1985), Y.-H. Lin (1988) and Bao (1990)). Consider the data from a fanqie language, May-ka, in (10) (unless otherwise indicated, all fanqie language data are taken from Chao (1931). Bao (1990) is an analysis of Chao's data, as well as data from J.-K. Li (1985) and Y.-H. Lin (1988)):

- (10) May-ka
- | | | |
|----|---------------|----------|
| a. | ma > may-ka | "mother" |
| b. | pən > pay-kən | "book" |
| c. | pey > pay-key | "north" |

An inspection of the data shows the following: 1. a fanqie word consists of two syllables, corresponding to a single source syllable; 2. one of the two syllables of a fanqie word retains the rime of the source syllable (I call this syllable the r-syllable, "r" for rime); the other retains the initial consonant of the source syllable (I call it the o-syllable, "o" for onset). Thus, the fanqie equivalent of pən is pay-kən (10b); the first syllable pay (the o-

5. This section is a modified version of §3 of Bao (1990). For details of the arguments and other theoretical assumptions, see Bao (1990).

Tone in Phonological Representation

syllable) retains the source initial consonant *p*; while the second syllable *kən* (the r-syllable) retains the source rime *ən*. The o-syllable obtains a new rime, and the r-syllable obtains a new onset segment. This is the general form of fanqie languages. The new onset segments for the r-syllable and new rimes for the o-syllable vary from one fanqie language to another. Thus, *Mey-ka* differs from *May-ka* in that the former fanqie language has /ey/ as the new rime, rather than /ay/:

(11) *Mey-ka*

- | | | |
|----|-----------------------------|----------|
| a. | <i>ma</i> > <i>mey-ka</i> | "mother" |
| b. | <i>pən</i> > <i>pey-kən</i> | "book" |
| c. | <i>pey</i> > <i>pey-key</i> | "north" |

In §4.2.2 we saw that the derivation of fanqie languages involves reduplication and substitution. The mechanism of fanqie language formation is as follows (Bao (1990)):

(12) Fanqie Language Formation (FLF):

- a. total copying of the source syllable (Steriade (1988))
- b. substitution operation on resultant string
- c. substitution can operate once on a given syllable

Substitution is defined for each fanqie language. For example, given the syllable structure in (13), *May-ka* and

Tone in Phonological Representation

Mey-ka can be derived by the substitution operations defined in (14) and (15) respectively:

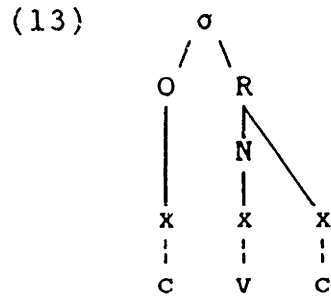

(14) May-ka:

- a. in the first syllable, replace the rime with [ay 15]_R
- b. in the second syllable, replace the onset-initial with /k/

(15) Mey-ka:

- a. in the first syllable, replace the rime with [ey 51]_R
- b. in the second syllable, replace the onset initial with /k/

Substitution is structure-preserving: it replaces a source constituent with a new constituent of the same type. The following derivations involving the source word ma "mother" illustrate how FLF works (a dot separates the onset from the rime; tones are omitted):

Tone in Phonological Representation

(16)	May-ka	Mey-ka
	Source	Source
	m.a	m.a
	Reduplication	Reduplication
	m.a-m.a	m.a-m.a
	Substitution (14a)	Substitution (15a)
	m.ay-m.a	m.ey-m.a
	Substitution (14b)	Substitution (15b)
	m.ay-k.a	m.ey-k.a

Other fanqie languages can be derived in the same fashion.

Now consider the tone patterns of fanqie languages. The relevant data are in (17):

(17)	a. May-ka	
	ma 55 > may 15 (11)-ka 55	"mother"
	pən 15 > pay 15 (35)-kən 15	"book"
	taw 51 > tay 15 (11)-kaw 51	"path"
	b. Mey-ka	
	ma 55 > mey 51-ka 55	
	pən 15 > pey 51-kən 15	
	taw 51 > tey 51-kaw 51	
	c. Man-t'a	
	mā 55 > man 55-t'a 55	
	pən 15 > pən 15 (35)-t'ən 15	
	taw 51 > tan 51-t'aw 51	

(The tones in parentheses are derived through tone sandhi.)
 Of the two syllables of a fanqie word, the r-syllable
 contains the source rime and carries the source tone in all

Tone in Phonological Representation

three fanqie languages. Our focus is on the o-syllable, which obtains a new rime. The tones on the o-syllable differ from the source tones in May-ka and Mey-ka. In Man-t'a, however, both the r-syllable and the o-syllable keep the source tone. We now observe that in May-ka and Mey-ka the nucleus of the o-syllable is /a/ (May-ka) or /e/ (Mey-ka) regardless of the vowel quality of the source syllable. In these two fanqie languages the o-syllable loses the source tone. In Man-t'a, by contrast, the vowel quality of the source syllable remains the same in both the o-syllable and the r-syllable. In this fanqie language, the o-syllable keeps the source tone. I express this observation in (18):

- (18) If the vowel of the source syllable remains in the o-syllable, the o-syllable keeps the source tone

Now consider the tone patterns of Mo-pa, Ma-sa, and La-pi:

- (19) a. Mo-pa

pã 33 > po 33-vã 33 "country"
ts'I 4 > ts'o 4-zI 4 "seven"

- b. Ma-sa (Yip (1982:641))

ma 3 > ma 5-sa 2
ti 5 > ti 5-si 2
kun 31 > kun 5-sun 2

- c. La-pi (Li (1985) and Lin (1988))

hyaw 53 > lyaw 53 (55)-hi 53
t'aw 13 > law 13 (33)-t'i 13
t'at 31 > lat 31 (53)-t'it 31

Tone in Phonological Representation

In Mo-pa (19a), the source tone is retained in both the r-syllable and the o-syllable; and the new rime and the new onset initial are /o/ and /p/ respectively. In Ma-sa (19b), the source tone disappears in both the r-syllable and o-syllable, and the new onset initial is /s/. In La-pi (19c), the source tone occurs on both syllables of the fanqie words. Furthermore, the o-syllable keeps the coda of the source syllable. The rime structure of the source syllable is preserved in the La-pi word. If the source syllable contains a coda, its La-pi equivalent contains the coda in both syllables.⁶ To preserve the rime structure, the locus of substitution must be the nucleus. I define the substitution operation which derives La-pi as follows:

- (20) La-pi
- a. in the first syllable, replace the onset initial with /l/
 - b. in the second syllable, replace the nucleus with [i]_N

Since the locus of the substitution operation is the nucleus, the source coda will remain in the o-syllable in

6. In La-pi, the coda consonant of the o-syllable defaults to the alveolar stop /t/:

tsap	>	lap-tsit	(*-tsip)	"ten"
t'at	>	lat-t'it		"kick"
pak	>	lak-pit	(*-pik)	"peel"

[p] and [k] in the second syllables in tsap and pak surface as tsat and pat respectively.

Tone in Phonological Representation

La-pi. Clearly, there is a correlation between the tone pattern and the presence of the source coda in the o-syllable in La-pi. I express this correlation in (21):

- (21) If the coda of the source syllable remains in the o-syllable, then the c-syllable keeps the source tone

Recall that (18) expresses the relation between the nucleus of the source syllable and the tone pattern of the o-syllable. Generalizing, we combine (18) and (21) as in

(22):

- (22) If either segmental constituent of the source rime remains in the o-syllable, then the o-syllable keeps the source tone

To summarize, we see that the tone patterns of fanqie languages as manifested on the o-syllable fall into the five categories enumerated in (23):

(23)

- a. new segmental rime; new tone (May-ka, Mey-ka)
- b. new segmental rime; source tone (Mo-pa)
- c. new coda; source tone (Man-t'a)
- d. new nucleus; source tone (La-pi)
- e. new tone on both syllables (Ma-sa)

To my knowledge (23) are the only tone patterns observed in fanqie languages that have been reported to date.

Tone in Phonological Representation

To characterize the set of possible tone patterns, and to derive the generalization (22), the structural relation of tone with respect to other aspects of the syllable, particularly the syllabic structure, is crucial. If tone is mapped onto the x-skeleton, there is no explanation why (23) constitutes the only tone patterns of fanqie languages, and why the generalization (22) should govern the tone patterns of fanqie languages. If, on the other hand, we assume that tone is an autosegmental tier on the syllabic plane, as in (24),

(24)

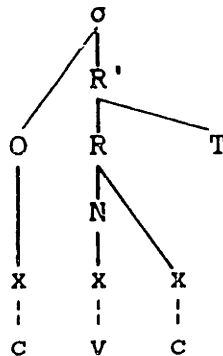

both the generalization (22) and the tone patterns in (23) follow as a direct consequence of the formal mechanism of FLF. In the structure in (24), c, v are the root nodes of consonantal and vocalic segments. For ease of reference, I will call the node R' the rime, and R the segmental rime. Note that substitution is a constituent operation defined over syllabic structure. In fanqie languages, the r-syllable always retains the tone of the source syllable.

Tone in Phonological Representation

This is so because the locus of substitution in deriving the r-syllable is the onset initial; such operation does not affect the tone (the T node) at all, as shown below:

(25) New Onset Initial

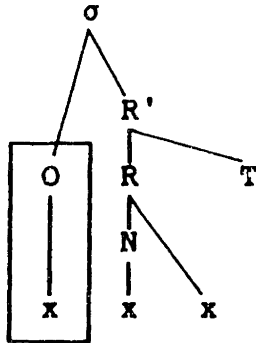

With respect to the o-syllable, there are four nodes which may serve as the locus of the substitution operation; as illustrated in (26) (the affected constituent is in the box):

(26)

a. New Rime

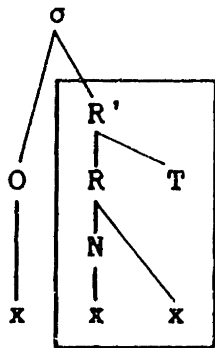

b. New Segmental Rime

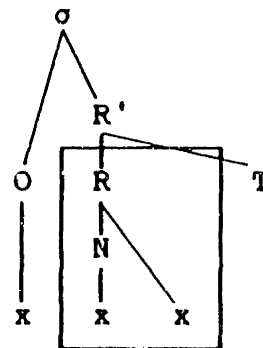

Tone in Phonological Representation

c. New Coda

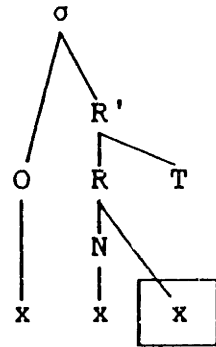

d. New Nucleus

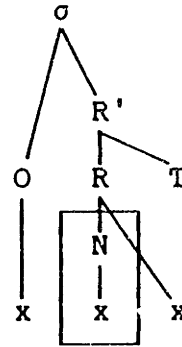

e. New Tone

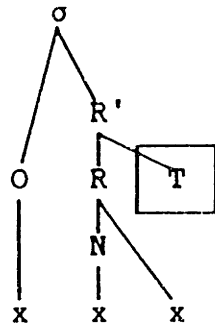

In (26a), the entire rime R' is the locus of substitution, hence the tone is also replaced. This is the tone pattern of May-ka and Mey-ka (cf. (17a,b)). In (26b), substitution operates on the segmental rime R ; the tone is retained since T is not dominated by R . This is the tone pattern of Mo-pa (cf. (19a)). In these two cases substitution produces the

Tone in Phonological Representation

same segmental effect; the only difference is the tone.⁷ In (26c), substitution affects the coda without affecting the tone. This is the tone pattern of Man-t'a, the o-syllable of which is derived by inserting a code /n/ (cf. (17c)). In (26d), the nucleus serves as the locus of the substitution operation; since N does not dominate T, T is retained. This is the tone pattern of La-pi (cf. (19c)). Lastly, in (26e), the substitution operation replaces the T node, in which case the fanqie language so derived will surface with the segmental material of the source syllable, and a new tone. This is the tone pattern of Ma-sa (cf. (19b)). As for the generalization in (22), if either the source coda or source nucleus is retained in the o-syllable, the locus of substitution must necessarily be a constituent dominated by the segmental rime node R. Tones will not be affected by such substitution operation. Thus, the tone patterns enumerated in (23) and the generalization (22) of fanqie languages follow from the mechanism of FLF and the structure of the syllable in (24), in which tone is represented as

7. This is the reason why we can not strengthen the generalization (22) into a biconditional:

- (i) either segmental constituent of the source rime remains in the o-syllable if and only if the o-syllable keeps the source tone

That is, it is possible that no segmental material of the source syllable is retained in the o-syllable even if the o-syllable keeps the source tone, as in Mo-pa.

Tone in Phonological Representation

forming an autosegmental tier on the syllabic plane.

Suppose that tones form an autosegmental plane, as in (27):

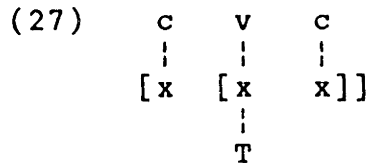

This structure satisfies the condition (4), which stipulates that elements on planes must be linked to x-slots. The T on the tonal plane, and c,v on the segmental plane are all linked to x-slots. The syllable structure is indicated by bracketing. Since they form a separate plane, tones will be maximally stable, and will not be affected no matter what syllabic constituent serves as the locus of the substitution operation. As an illustration, consider the derivation of May-ka and La-pi:

Tone in Phonological Representation

(28)	May-ka		La-pi
	m a		t' a t
	[x [x]]		[x [x x]]
	55		31
	Reduplication		Reduplication
	m a m a		t' a t t' a t
	[x [x]] [x [x]]		[x [x x]] [x [x x]]
	55 55		31 31
	Substitution (14)		Substitution
	m a y k a		l a t t' i t
	[x [x x]] [x [x]]		[x [x x]] [x [x x]]
	15 55		31 31
	may 15 (11) ka 55		lat 31 (53)-t'it 31

In the derivation of the La-pi example, substitution replaces the onset initial of the first syllable with /l/ and the nucleus of the second syllable with /i/. In May-ka, however, the tone is replaced along with the segmental material of the rime, tones do not exhibit stability in cases like May-ka. Since tones may be affected along with segments, we would expect to have a fanqie language of the following form:

(29) t'at 31 > lat 31-t'it 15

This hypothetical fanqie language is similar to La-pi with one exception: the source tone 31 is replaced by the new

Tone in Phonological Representation

tone 15, along with the nucleus segment /i/. This hypothetical form does not exist in the reported literature on fanqie languages. The structure in which tones are represented on a separate plane fails to adequately characterize the tone patterns observed in fanqie languages. There is no principled explanation for the tone patterns in (23) and the generalization in (22).

I conclude that fanqie language data provide evidence for the structure proposed in (24). Tones form an autosegmental tier on the syllabic plane.

5.3 Segmentalization of Tone

In this section I consider the lexical representation of tone, and its segmentalization. As far as tonal phonology is concerned, the lexical representation provides the input to tone sandhi rules, after which segmentalization occurs. The phonological component of tone sandhi I assume is schematized below:

(30) Organization of Tone Sandhi Component

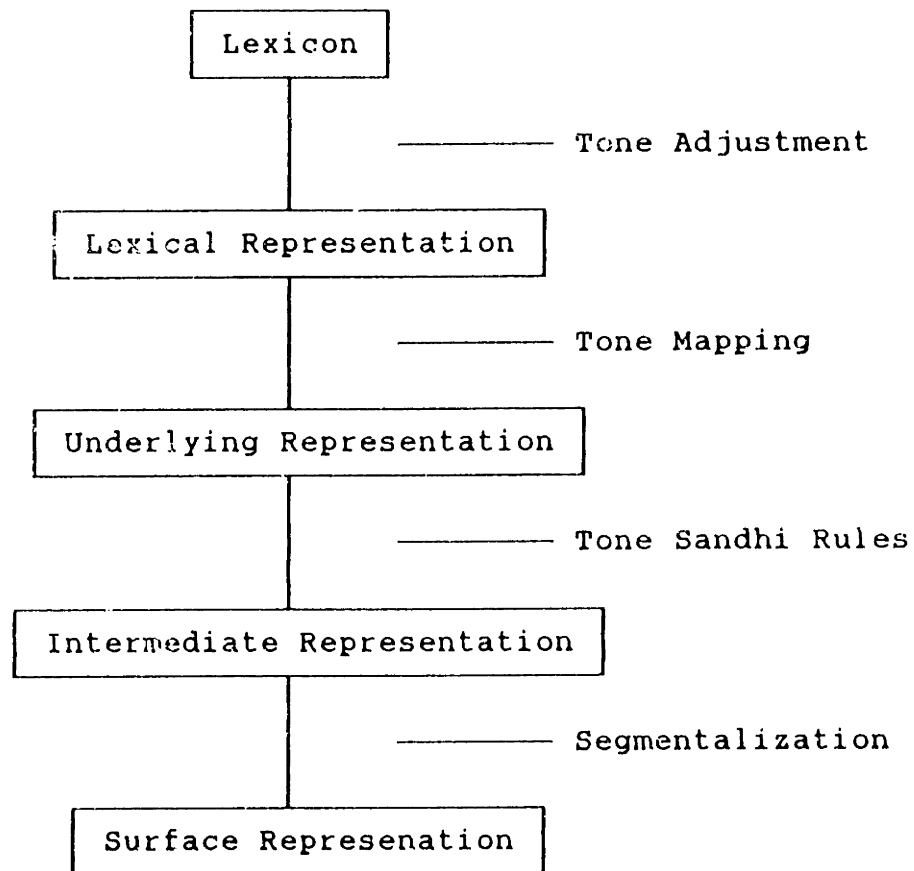

Given a monosyllabic morpheme with the segments p,a,k and tone t, I assume that the phonological component of the morpheme has the following form in the lexicon:⁸

8. Strictly speaking, the segments p,a,k should be the root node of the feature geometry which defines the segments. Since the discussion does not hinge on the internal geometrical structure of the segmental feature trees, I use the segments as short hand symbols.

(31)

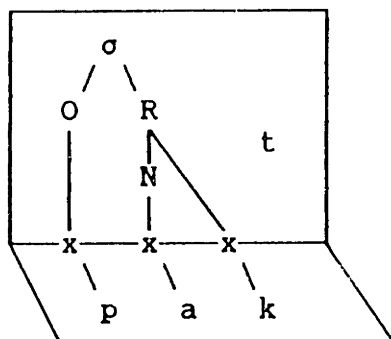

Polysyllabic strings are concatenated of the structure in (31). Tone adjustment rules apply to strings having the syllabic structure (31). These rules adjust the tone in accordance with the segmental information. They are of the form (32):⁹

9. Tone adjustment rules look like readjustment rules in the sense of Chomsky and Halle (1968) and Halle (1990). But there is a crucial difference. Readjustment rules are "feature-filling" redundancy rules, while tone adjustment rules can be viewed as feature-changing. Take (38a) for example. In this tone adjustment rule, the feature [stiff] changes from [+stiff] to [-stiff]. Other tone adjustment rules have more complex feature-changing operations (cf. rules in (45)). But readjustment rules and tone adjustment rules are similar in that both "prepare" the input structure for the phonological component. In Chinese, the need for tone adjustment rules is due to historical tonal split: one tone splits into two variants after voicing has become nondistinctive. Tonal variants often reveal their common historical origin in tone sandhi. In Wuyi, 24 and 213 on the one hand, and 55 and 13 on the other have exactly the same sandhi behavior. For this reason {24,213} and {55,13} are referred to as tone classes in Chinese linguistics. Historically, {24,213} is derived from the ping (Even) tone in Classical Chinese; {55,13} from the shang (Rising) tone.

Tone in Phonological Representation

$$(32) \quad t_1 \dashrightarrow t_2 / \begin{array}{c} O \\ | \\ x \\ | \\ Rt \\ | \\ LAR \\ | \\ \alpha F \end{array}$$

Tone adjustment rules therefore make reference to information on the segmental plane. Note that tone is not associated with any constituent at the time when tone adjustment rules apply. The issue of trans-planar conditioning does not arise (more on this issue later). Tone adjustment rules can be generalized to include other constituent of the syllable. For the present purpose, these rules are intended to handle co-occurrence restrictions between onset segments and tones on the following vowels within the same syllable, a phenomenon which I will refer to as onset-tone harmony. Therefore only onset segmental information will figure in the formulation of such rules.

By "lexical representation" I mean the string resulting from morpheme concatenation as modified by tone adjustment rules. Tone Mapping maps tones, which are unassociated in the lexical representation, to the appropriate tone-bearing units, forming an autosegmental tier of tone on which tonal computation is performed. The rules of tonal computation are referred to as tone sandhi rules. After tone sandhi rules have applied, tones are segmentalized -- tones are

Tone in Phonological Representation

phonetically realized on the vowels (or other nuclear elements). The subcomponents in (30), Tone Adjustment, Tone Mapping, Tone Sandhi Rules and Segmentalization, may be viewed as functions which take two representations as arguments. Thus, Tone Mapping relates the lexical representation of a form to the underlying representation. The schema in (30) imposes a strict ordering relation among the subcomponents. In this section I will discuss Tone Mapping and Segmentalization. Rule types of tone sandhi will be discussed in §5.4.

Tone mapping, however, is not as straightforward as putting tones on the syllabic plane. In many Chinese dialects, particularly of the Wu variety, a tone has two variants conditioned by the voicing qualities of syllable-initial segments. The tone/segment segregation raises questions about the trans-planar interaction between the syllable-initial segment and the tone on the following vowel. There are three cases to consider, two of which present no problem. First, in languages which do not have voiced obstruents, the laryngeal features [stiff] and [slack] are nondistinctive. There is no interaction between syllable-initial segments and tones in such languages, which are exemplified by most Mandarin dialects of Chinese, among them, Changzhi (§3.3.1.2), Zhenjiang (§3.3.3.1) and Pingyao (§3.3.2). Secondly, there are languages which do have voiced

obstruents, but exhibit no interaction between the obstruents and tones. Weining Miao (§3.2 and Chapter Six) is such a language. Its high tones and low tones are not in complementary distribution with respect to the voicing qualities of syllable-initial segments. These two cases present no problem because there is no interaction between segments on one plane and tones on another.

Thirdly, there are languages which have a strict correlation between the voicing qualities of syllable-initial segments and tone registers. Songjiang is a paradigm example. Its tone inventory is shown in in (33):

(33) Tonal Inventory of Songjiang

yin-register

a.	53	ti "low";	t'i "ladder"
b.	44	ti "bottom";	t'i "body"
c.	35	ti "emperor";	t'i "tear"
d.	5	pa? "hundred";	p'a? "tap"

yang-register

A.	31	di "lift"
B.	22	di "brother"
C.	13	di "field"
D.	3	ba? "white"

In languages which exhibit onset-tone harmony, the tone registers are predictable from the onset obstruents of the syllables on which they are realized. The bi-planar representation of tones and segments makes it difficult to characterize onset-tone harmony. Suppose that 44 is the

underlying tone from which 22 is derived. The representations of ti 44 "bottom" and di 22 "brother" (33b,B) are as follows:

(34) a. Bi-planar Structure of ti 44 "bottom"

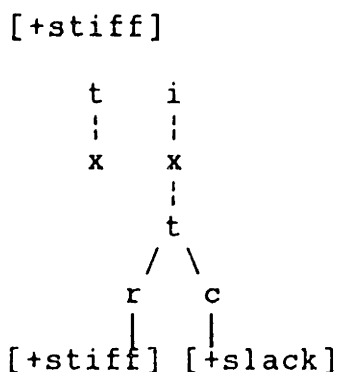

b. Bi-planar Structure of di 22 "brother"

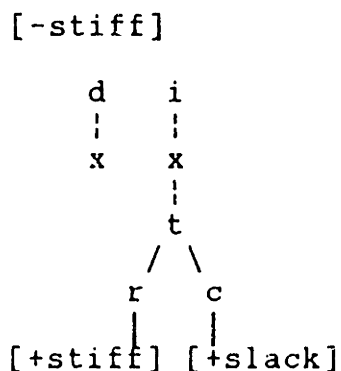

In (34) I indicate that /t/ is specified as [+stiff] and /d/ as [-stiff] without specifying the full feature trees of the two phonemes. Notice that in Songjiang voiced obstruents always occur with [-stiff] tones, and voiceless obstruents always occur with [+stiff] tones (but see Songjiang's sound system in the Appendix). So the structure in (34b) must undergo some lowering process so that [L,l] will surface

instead of the underlying [H,l]. It appears that the tonal register assimilates into the preceding segment, between two autosegmental planes.

While the two series of tones in Songjiang's tonal inventory differs in register as conditioned by the voicing qualities of syllable-initial segments, other dialects display more complex alternations. Wenling is a case in point. Wenling has eight tones in citation form, shown in (35) (R. Li (1979)):

(35)	a.	33	A.	31	(Ping)
	b.	42	B.	31	(Shang)
	c.	55	C.	13	(Qu)
	d.	5	D.	1	(Ru)

(35a-d) are used with voiceless initial segments, (35A-D) are used with voiced initial segments. Note that (35A) and (35B) both surface as 31 when used with voiced initial syllables. According to Li, they are derived from different underlying tones because they exhibit different sandhi behavior. The tonal inventory of Wenling suggests that the onset-tone harmony is not a result of register assimilation. In the case of (35c) and (35C), the alternation involves both the register (H to L) and the contour (even to rising).

To account for the phenomenon of onset-tone harmony, I assume that the lexical representation of monosyllabic morphemes in languages like Songjiang and Wenling contains a single tone regardless of the voicing qualities of the

Tone in Phonological Representation

syllable-initial segments. Moreover, tones are free, unassociated with any constituent. They are mapped to the tone-bearing units according to well-known association principles (see Chapter One). For instance, the phonological components of the lexical entries of ti 44 "bottom" and di 22 "brother" have the structures in (36):

- (36) a. Lexical Entry of ti 44 "bottom"

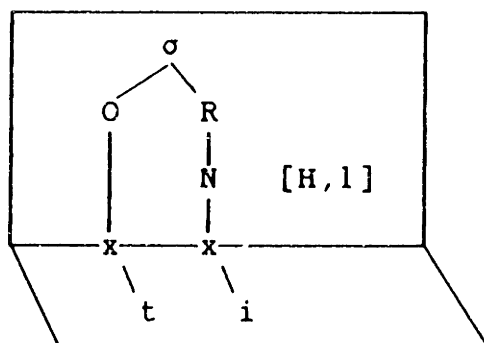

- b. Lexical Entry of di 22 "brother"

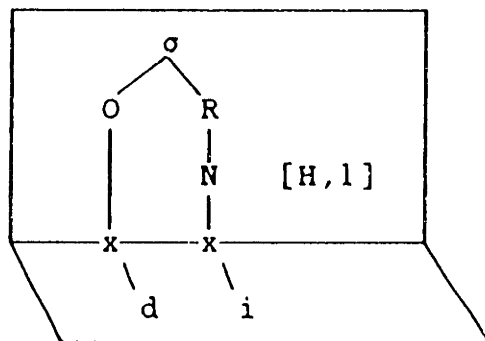

Polysyllabic morphemes are concatenated of syllables having the structure in (36). Tone mapping adjoins tone to the tone-bearing unit; in the case of (36), to the R node. It

creates the structure in (37):¹⁰

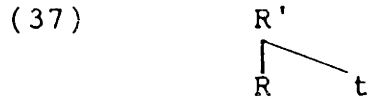

In this structure, temporal precedence does not hold between R and t. The tonal tier, t, is orthogonal to the temporal dimension. Onset-tone harmony is derived before tone mapping by means of tone adjustment rules, which must make reference to syllable-initial segments. The tone adjustment rules of Songjiang may be formulated as follows (sub-R structure is suppressed):

10. Instead of considering tone mapping as an adjunction rule, we can assume that the structure in (37) as part of the syllable structure pre-specified in the lexicon. The maximal syllable structure for Mandarin Chinese may thus look like the following,

(i)

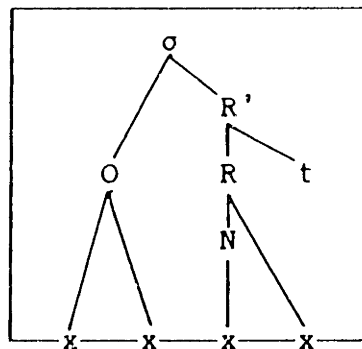

Tones are pre-specified as a node dominated by R'.

Tone in Phonological Representation

(38) Tone Adjustment Rules of Songjiang

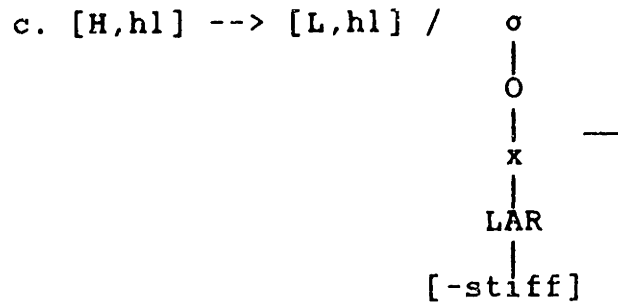
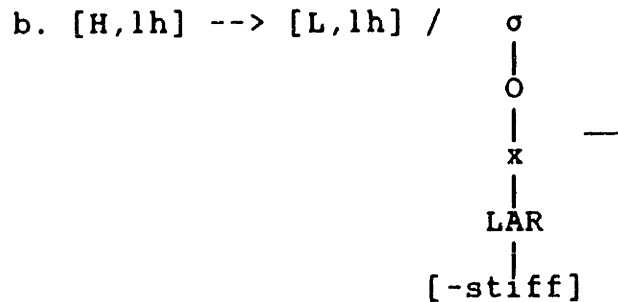
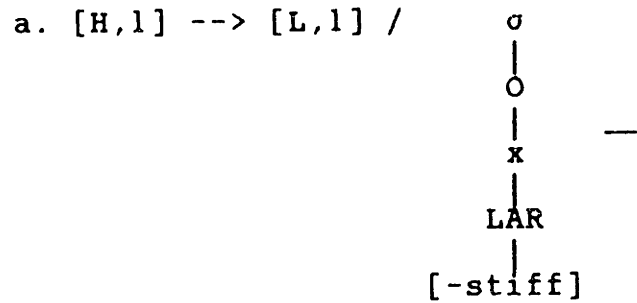

The rules in (38) describe the same process, that of register lowering. It is possible to collapse them into a single rule; I keep them for illustrative purposes. Rule (38a) derives [L,l] from [H,l] in (36b). Tone mapping adjoins tones to the R node, creating the structures below:

Tone in Phonological Representation

(39) a.

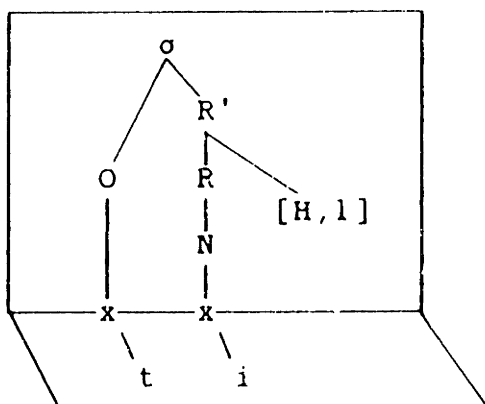

b.

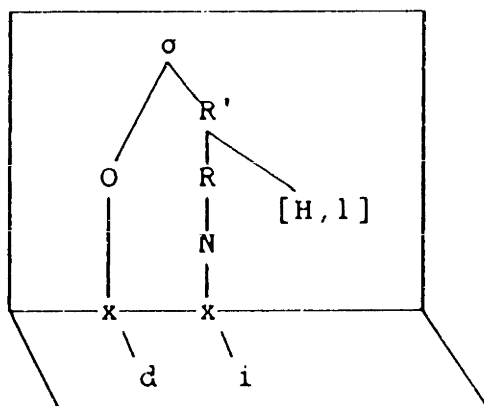

In order to see how the various rules sketched above work, consider now the bisyllabic tone sandhi data from Wuyi. Wuyi has the following tonal inventory (G.-T. Fu (1984); see the Appendix for the sound systems of the language):

(40)	a.	24	b.	55	c.	53	d.	5
	A.	213	B.	13	C.	31	D.	<u>212</u>

The tones (40d,D) are short tones occurring in syllables ending in the glottal stop. Historically, (40a,A), (40b,B), (40c,C) and (40d,D) are derived from a single tone, which

Tone in Phonological Representation

splits into a yin variant (40a), (40b), (40c) or (40d) and a yang variant (40A), (40B), (40C) or (40D). I will include historically related tones within curly brackets, such as {24,213}.

In bisyllabic phrases the first tone undergoes tone sandhi. The sandhi patterns are shown as follows (the vertical axis represents the first tone; the horizontal axis represents the second tone):

(41) Bisyllabic Tone Patterns of Wuyi

	24	213	53	31	55	13
24	55-					
213						
53	11-					
31						
55						
13						

The second tone in a bisyllabic phrase does not show sandhi effects. The tone sandhi patterns shown in (41) happens generally, with the exception of the patterns {24,213}-{24,213} and {24,213}-{53,31} in phrases other than the verb-object construction. These exceptional sandhi patterns were discussed in §4.3. Relevant data are given in (42) through (45).

Tone in Phonological Representation

- (42) a. {24,213}-24 > 55-24
- | | | |
|-----------------|--|-------------------|
| k'a tɕ'ia | | "drive a car" |
| ts'au ɕy | | "copy books" |
| puə (< buə) suo | | "climb mountains" |
| tuo (< duo) ɕy | | "take a book" |
- b. {24,213}-213 > 55-213
- | | | |
|------------------|--|---------------------------|
| ka die | | "plow fields" |
| tsu vaŋ | | "rent a house" |
| ta (< da) dau | | "raise the head" |
| tuo (< duo) dʒiŋ | | "play musical instrument" |
- c. {24,213}-53 > 55-53
- | | | |
|--------------------|--|-------------------|
| tsa ts'a | | "plant vegetable" |
| puo huo | | "ship products" |
| sa (< za) pu | | "buy cloth" |
| tsua (< dzua) p'ie | | "check tickets" |
- d. {24,213}-31 > 55-31
- | | | |
|-----------------|--|-------------------|
| tsa-ɰy | | "plant trees" |
| ka di | | "plow fields" |
| tig (< dig) die | | "cut electricity" |
| pia (< bia) da | | "line up" |
- e. {24,213}-55 > 55-55
- | | | |
|---------------------|--|----------------|
| tɕ'ig ts'u | | "clear" |
| t'ie tɕig | | "courtyard" |
| ʔɣua (< fiɣua) ts'ɿ | | "teeth" |
| tog (< dog) ʔmuo | | "copper plate" |
- f. {24,213}-13 > 55-13
- | | | |
|-------------------|--|---------------|
| kog ɰia | | "commune" |
| tsog fiəu | | "honest" |
| pəŋ (< bəŋ) fiəu | | "friend" |
| tɕi (< dɰi) fiɰua | | "ride horses" |

Tone in Phonological Representation

- (43) a. 53-24 > 55-24
 huɔ tɕ'ia "truck"
 fəŋ ɕiŋ "at ease"
- b. 53-213 > 55-213
 t'ie dau "cut hair"
 ɕi da "stage"
- c. 53-53 > 55-53
 ɕie tɕia "world"
 fuŋ tɕ'i "abandon"
- d. 53-31 > 55-31
 tɕiŋ dɕi "politics"
 ɕiŋ bu "progress"
- e. 53-55 > 55-55
 pəu tɕi "newspaper"
 kuɔ huɔ "overdo"
- f. 53-13 > 55-13
 t'ie vu "dance"
 sɔŋ ɱlie "give gifts"
- (44) a. 31-24 > 11-24
 duɔ ku "aunt"
 di fəŋ "place"
- b. 31-213 > 11-213
 gɔŋ dɔŋ "common"
 dɕi ɱlɔŋ "chopstick
 holder"
- c. 31-53 > 11-53
 bie ʔnɔŋ "convenient"
 ɱɱia t'ɣ "jacket"
- d. 31-31 > 11-31
 di dɔŋ "tunnel"
 die ɱua "telephone"

Tone in Phonological Representation

- e. 31-55 > 11-55
 di tɕy "landlord"
 h̩uəi k'uo "money order"
- f. 31-13 > 11-13
 vi dɣ "taste"
 duo h̩y "big rain"
- (45) a. {55,13}-24 > 11-24
 p̩hu (< p'u) t'og "ordinary"
 h̩huo (< huo) tɕ'a "train"
 bi k'uo "bedding"
 h̩mu tɕ'ig "mother"
- b. {55,13}-213 > 11-213
 bie (< pie) h̩iaŋ "praise"
 ɰy (< ɕy) h̩u "water kettle"
 du ɰie "navel"
 h̩ia h̩muo "savage"
- c. {55,13}-53 > 11-53
 ga (< ka) tɕig "improve"
 k̩h̩au (< k'au) ɕi "examination"
 h̩guo tɕig "glasses"
 za kuo "fault"
- d. {55,13}-31 > 11-31
 gu (< ku) da "antiquity"
 ts̩h̩au (< ts'au) h̩mie "fried noodles"
 ɰia h̩uəi "society"
 bu da "army"
- e. {55,13}-55 > 11-55
 tɕ̩hi (< tɕ'i) ɕi "begin"
 h̩huo (< huo) t'a "ham"
 h̩na ɕy "cold water"
 h̩y suo "umbrella"

Tone in Phonological Representation

f. {55,13}-13 > 11-13

gag (< kag) fɲie	"make a speech"
gua (< kua) vu	"widow"
vu fɲu	"parents"
fɲu ba	"gossip"

As the data indicate, syllable-initial segments devoice if tones become H-registered as a result of tone sandhi (42); and voice if tones surface as L-registered (45). Tone adjustment rules account for the influence of syllable-initial segments on tones. The onset-tone harmony in (42) and (45) shows that tones can also influence voicing and devoicing.

To characterize the tone patterns in (41), we focus on the first tone. Observe that {24,213} and the H variant of {53,31} surface as 55; {55,13} and 31, the L variant of {53,31}, surface as 11. Suppose that 24, 53 and 13 are the underlying tones, and have the structures [H, lh], [H, hl] and [L, h] respectively. The other tones can be derived by the tone adjustment rules formulated below:^{11,12}

11. The reason to represent 13 as [L, h] has to do with the fact that 13 surfaces as 11 in sandhi environment. The surface rising contour is derived by the feature-inserting rule (i):

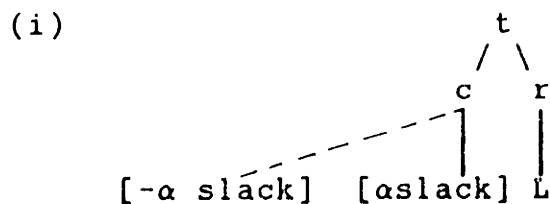

Tone in Phonological Representation

- (46) a. [H, lh] --> [L, lh] / σ]
 |
 O
 |
 x —
 |
 LAR
 |
 [-stiff]
- b. [H, hl] --> [L, hl] / σ
 |
 O
 |
 x —
 |
 LAR
 |
 [-stiff]
- c. [L, h] --> [H, h] / σ]
 |
 O
 |
 x —
 |
 LAR
 |
 [+stiff]

The three tone adjustment rules in (46) do not apply in identical phonological environments. Only (46b) applies to the underlying tone [H,hl] regardless of its environment. By contrast, the rules (46a) and (46c) are formulated so that they apply to tones in phrase-final position, as indicated

The rule inserts l to the c node of l3, giving rise to [L, lh]. The same rule also derives 213: [L, lh] --> [L, hlh].

12. The rules in (46) all involve the register, it appears to be possible to formulate a single rule which produces the same effect. This approach is not desirable since the three tone adjustment rules in (46) apply in different environments.

Tone in Phonological Representation

by a right square bracket]. They apply to tones in citation and phrase-final positions, but not in phrase-initial position. By contrast, (46b) is not restricted. It applies to tones in all positions. In citation form as well in phrase-final position, (46a) derives 213 from 24 and (46c) derives 55 from 13. (46b) derives 31 from 53 in all positions.

Given the underlying tones [H,1h], [H,h1] and [L,h], the most economical way to derive the sandhi patterns in (41) is the following rule:

$$(47) \quad c \rightarrow c \quad / \quad [_]$$

|
[+slack]

The rule applies just in case the tone is phrase-initial. The rule derives [H,1] from a H-registered tone and [L,1] from a L-registered tone. [H,1] surfaces as 55; [L,1] as 11. Consider the derivation in (48) which involves tone adjustment rule (46a) (full structures are suppressed):

(48) a. Derivation of tuo 55 əy 213 "take a book"

Lexical Representation

[H,1h]	[H,1h]
duo	əy

Tone Adjustment

Not Applicable

Tone Mapping

[H,1h]	[H,1h]
duo	əy

Tone in Phonological Representation

Sandhi Rule (47)	[H,l]	[H,lh]
	duo	ɸY
Devoicing	[H,l]	[H,lh]
	tuo	ɸY

b. Derivation of ka 55 die 213 "plow fields"

Lexical Representation	<table style="border: 1px solid black; padding: 5px; margin: auto;"> <tr> <td style="padding: 2px 10px;">[H,lh]</td> <td style="padding: 2px 10px;">[H,lh]</td> </tr> <tr> <td style="padding: 2px 10px;">ka</td> <td style="padding: 2px 10px;">die</td> </tr> </table>	[H,lh]	[H,lh]	ka	die		
[H,lh]	[H,lh]						
ka	die						
Tone Adjustment (46a)	<table style="border: 1px solid black; padding: 5px; margin: auto;"> <tr> <td style="padding: 2px 10px;">[H,lh]</td> <td style="padding: 2px 10px;">[L,lh]</td> </tr> <tr> <td style="padding: 2px 10px;">ka</td> <td style="padding: 2px 10px;">die</td> </tr> </table>	[H,lh]	[L,lh]	ka	die		
[H,lh]	[L,lh]						
ka	die						
Tone Mapping	<table style="border-collapse: collapse; margin: auto;"> <tr> <td style="text-align: center; padding-right: 20px;">[H,lh]</td> <td style="text-align: center;">[L,lh]</td> </tr> <tr> <td style="text-align: center;"> </td> <td style="text-align: center;"> </td> </tr> <tr> <td style="text-align: center;">ka</td> <td style="text-align: center;">die</td> </tr> </table>	[H,lh]	[L,lh]			ka	die
[H,lh]	[L,lh]						
ka	die						
Sandhi Rule (47)	<table style="border-collapse: collapse; margin: auto;"> <tr> <td style="text-align: center; padding-right: 20px;">[H,l]</td> <td style="text-align: center;">[L,lh]</td> </tr> <tr> <td style="text-align: center;"> </td> <td style="text-align: center;"> </td> </tr> <tr> <td style="text-align: center;">ka</td> <td style="text-align: center;">die</td> </tr> </table>	[H,l]	[L,lh]			ka	die
[H,l]	[L,lh]						
ka	die						

Note that tone adjustment rule (46a) does not apply to phrase-initial syllables. This accounts for the fact that the phrase-final tone [H,lh] is replaced by [L,lh], but the phrase-initial [H,lh] surfaces as [H,h], due to (47). The H-registered even tone eventually causes the initial consonant to devoice.

Now consider the effect of (46b) in the derivations in (49):

Tone in Phonological Representation

(49) a. Derivation of t'ie 53 vu 13 "dance"

Lexical Representation	<table style="border-collapse: collapse; margin: 0 auto;"> <tr> <td style="padding: 5px;">[H,hl]</td> <td style="padding: 5px;">[L,h]</td> </tr> <tr> <td style="padding: 5px;">t'ie</td> <td style="padding: 5px;">vu</td> </tr> </table>	[H,hl]	[L,h]	t'ie	vu
[H,hl]	[L,h]				
t'ie	vu				

Tone Adjustment	Not applicable
-----------------	----------------

Tone Mapping	<table style="border-collapse: collapse; margin: 0 auto;"> <tr> <td style="padding: 5px;">[H,hl]</td> <td style="padding: 5px;">[L,h]</td> </tr> <tr> <td style="text-align: center;"> </td> <td style="text-align: center;"> </td> </tr> <tr> <td style="padding: 5px;">t'ie</td> <td style="padding: 5px;">vu</td> </tr> </table>	[H,hl]	[L,h]			t'ie	vu
[H,hl]	[L,h]						
t'ie	vu						

Sandhi Rule (47)	<table style="border-collapse: collapse; margin: 0 auto;"> <tr> <td style="padding: 5px;">[H,l]</td> <td style="padding: 5px;">[L,h]¹³</td> </tr> <tr> <td style="text-align: center;"> </td> <td style="text-align: center;"> </td> </tr> <tr> <td style="padding: 5px;">t'ie</td> <td style="padding: 5px;">vu</td> </tr> </table>	[H,l]	[L,h] ¹³			t'ie	vu
[H,l]	[L,h] ¹³						
t'ie	vu						

b. Derivation of duo 11 ku 24 "aunt"

Lexical Representation	<table style="border-collapse: collapse; margin: 0 auto;"> <tr> <td style="padding: 5px;">[H,hl]</td> <td style="padding: 5px;">[H,1h]</td> </tr> <tr> <td style="padding: 5px;">duo</td> <td style="padding: 5px;">ku</td> </tr> </table>	[H,hl]	[H,1h]	duo	ku
[H,hl]	[H,1h]				
duo	ku				

Tone Adjustment (47b)	<table style="border-collapse: collapse; margin: 0 auto;"> <tr> <td style="padding: 5px;">[L,hl]</td> <td style="padding: 5px;">[H,1h]</td> </tr> <tr> <td style="padding: 5px;">duo</td> <td style="padding: 5px;">ku</td> </tr> </table>	[L,hl]	[H,1h]	duo	ku
[L,hl]	[H,1h]				
duo	ku				

Tone Mapping	<table style="border-collapse: collapse; margin: 0 auto;"> <tr> <td style="padding: 5px;">[L,hl]</td> <td style="padding: 5px;">[H,1h]</td> </tr> <tr> <td style="text-align: center;"> </td> <td style="text-align: center;"> </td> </tr> <tr> <td style="padding: 5px;">duo</td> <td style="padding: 5px;">ku</td> </tr> </table>	[L,hl]	[H,1h]			duo	ku
[L,hl]	[H,1h]						
duo	ku						

Sandhi Rule (47)	<table style="border-collapse: collapse; margin: 0 auto;"> <tr> <td style="padding: 5px;">[L,l]</td> <td style="padding: 5px;">[H,1h]</td> </tr> <tr> <td style="text-align: center;"> </td> <td style="text-align: center;"> </td> </tr> <tr> <td style="padding: 5px;">duo</td> <td style="padding: 5px;">ku</td> </tr> </table>	[L,l]	[H,1h]			duo	ku
[L,l]	[H,1h]						
duo	ku						

Since (46b) is not restricted to any environment, [H,hl] lowers to [L,hl] in phrase-initial position (cf. (49b)). It surfaces as the low even tone [L,l].

13. The tone [L,h] surfaces as 13. See footnote 11.

Tone in Phonological Representation

We now consider (46c), which is like (46a) in that it only applies to tones in phrase-initial position:

(50) Derivation of ɰy 11 ɦu 213 "kettle"

Lexical Representation	<table style="border-collapse: collapse; width: 100%; text-align: center;"> <tr> <td style="padding: 5px;">[L,h]</td> <td style="padding: 5px;">[H,1h]</td> </tr> <tr> <td style="padding: 5px;">ɰy</td> <td style="padding: 5px;">ɦu</td> </tr> </table>	[L,h]	[H,1h]	ɰy	ɦu		
[L,h]	[H,1h]						
ɰy	ɦu						
Tone Adjustment (46a)	<table style="border-collapse: collapse; width: 100%; text-align: center;"> <tr> <td style="padding: 5px;">[L,h]</td> <td style="padding: 5px;">[L,1h]</td> </tr> <tr> <td style="padding: 5px;">ɰy</td> <td style="padding: 5px;">ɦu</td> </tr> </table>	[L,h]	[L,1h]	ɰy	ɦu		
[L,h]	[L,1h]						
ɰy	ɦu						
Tone Mapping	<table style="border-collapse: collapse; width: 100%; text-align: center;"> <tr> <td style="padding: 5px;">[L,h]</td> <td style="padding: 5px;">[L,1h]</td> </tr> <tr> <td style="padding: 5px;">⋮</td> <td style="padding: 5px;">⋮</td> </tr> <tr> <td style="padding: 5px;">ɰy</td> <td style="padding: 5px;">ɦu</td> </tr> </table>	[L,h]	[L,1h]	⋮	⋮	ɰy	ɦu
[L,h]	[L,1h]						
⋮	⋮						
ɰy	ɦu						
Tone Sandhi (47)	<table style="border-collapse: collapse; width: 100%; text-align: center;"> <tr> <td style="padding: 5px;">[L,l]</td> <td style="padding: 5px;">[L,1h]</td> </tr> <tr> <td style="padding: 5px;">⋮</td> <td style="padding: 5px;">⋮</td> </tr> <tr> <td style="padding: 5px;">ɰy</td> <td style="padding: 5px;">ɦu</td> </tr> </table>	[L,l]	[L,1h]	⋮	⋮	ɰy	ɦu
[L,l]	[L,1h]						
⋮	⋮						
ɰy	ɦu						
Voicing	<table style="border-collapse: collapse; width: 100%; text-align: center;"> <tr> <td style="padding: 5px;">[L,l]</td> <td style="padding: 5px;">[L,1h]</td> </tr> <tr> <td style="padding: 5px;">⋮</td> <td style="padding: 5px;">⋮</td> </tr> <tr> <td style="padding: 5px;">ɰy</td> <td style="padding: 5px;">ɦu</td> </tr> </table>	[L,l]	[L,1h]	⋮	⋮	ɰy	ɦu
[L,l]	[L,1h]						
⋮	⋮						
ɰy	ɦu						

In this derivation, the tone adjustment rule (46a) applies to lower the second tone, but (46c) does not apply; the underlying tone [L,h] surfaces as [L,l] after tone sandhi rule (47). The L-registered tone causes the initial segment to voice. In the following derivation, (46c) applies to the second tone, but not to the first tone:

Tone in Phonological Representation

(51) Derivation of *h̃y ll suo 55* "umbrella"

Lexical Representation	<table style="border-collapse: collapse; margin: 0 auto;"> <tr> <td style="padding: 5px;">[L,h]</td> <td style="padding: 5px;">[L,h]</td> </tr> <tr> <td style="padding: 5px;"><i>h̃y</i></td> <td style="padding: 5px;"><i>suo</i></td> </tr> </table>	[L,h]	[L,h]	<i>h̃y</i>	<i>suo</i>
[L,h]	[L,h]				
<i>h̃y</i>	<i>suo</i>				

Tone Adjustment (46c)	<table style="border-collapse: collapse; margin: 0 auto;"> <tr> <td style="padding: 5px;">[L,h]</td> <td style="padding: 5px;">[H,h]</td> </tr> <tr> <td style="padding: 5px;"><i>h̃y</i></td> <td style="padding: 5px;"><i>suo</i></td> </tr> </table>	[L,h]	[H,h]	<i>h̃y</i>	<i>suo</i>
[L,h]	[H,h]				
<i>h̃y</i>	<i>suo</i>				

Tone Mapping	<table style="border-collapse: collapse; margin: 0 auto;"> <tr> <td style="padding: 5px;">[L,h]</td> <td style="padding: 5px;">[H,h]</td> </tr> <tr> <td style="text-align: center; padding: 5px;"> </td> <td style="text-align: center; padding: 5px;"> </td> </tr> <tr> <td style="padding: 5px;"><i>h̃y</i></td> <td style="padding: 5px;"><i>suo</i></td> </tr> </table>	[L,h]	[H,h]			<i>h̃y</i>	<i>suo</i>
[L,h]	[H,h]						
<i>h̃y</i>	<i>suo</i>						

Tone Sandhi (47)	<table style="border-collapse: collapse; margin: 0 auto;"> <tr> <td style="padding: 5px;">[L,l]</td> <td style="padding: 5px;">[H,h]</td> </tr> <tr> <td style="text-align: center; padding: 5px;"> </td> <td style="text-align: center; padding: 5px;"> </td> </tr> <tr> <td style="padding: 5px;"><i>h̃y</i></td> <td style="padding: 5px;"><i>suo</i></td> </tr> </table>	[L,l]	[H,h]			<i>h̃y</i>	<i>suo</i>
[L,l]	[H,h]						
<i>h̃y</i>	<i>suo</i>						

As a result the onset segment of the second syllable does not voice.

The voicing and devoicing effects of tone sandhi can be seen as autosegmental spreading of the register of tone after it has been segmentalized. I state the tone segmentalization rule as follows:¹⁴

(52) Segmentalization of Tone

Link tone to the laryngeal node of the nucleus segment

14. It is possible to formulate the segmentalization rule as involving the head of the syllabic constituent which serves as the tone-bearing unit. If we view syllabic structure as the projection of vowels (sonorants), then vowels are heads in the same way that a verb is the (lexical) head of VP.

Tone in Phonological Representation

(52) maps (53a) to (53b), which is equivalent to (53c):

(53) a.

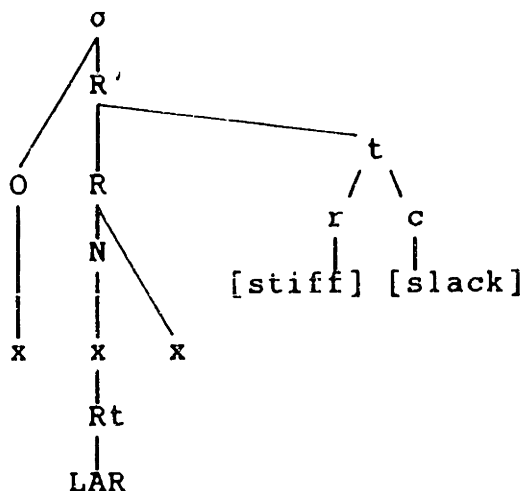

b.

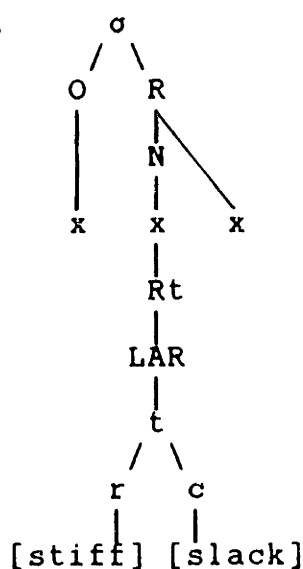

c.

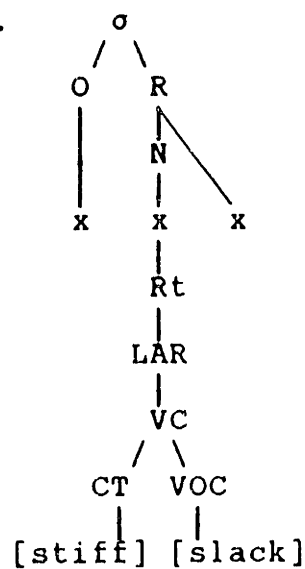

After the segmentalization of tone, voicing and devoicing may take place. These are assimilatory phenomena involving the spreading of the r node (i.e. the CT node) from the vowel to the preceding onset segment, as shown in (54). The derivation starts after the sandhi rule (47) (Rt=root, LAR=laryngeal, st=stiff):

Tone in Phonological Representation

(54) Continuation of (48a) tuo 55 sy 213

Segmentalization

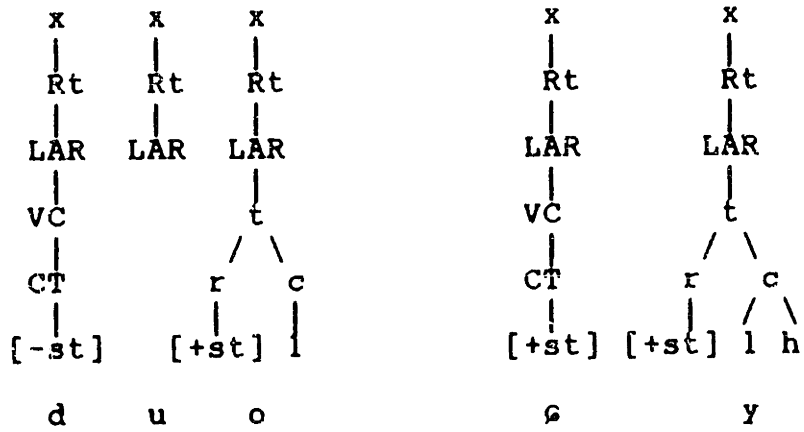

Devoicing

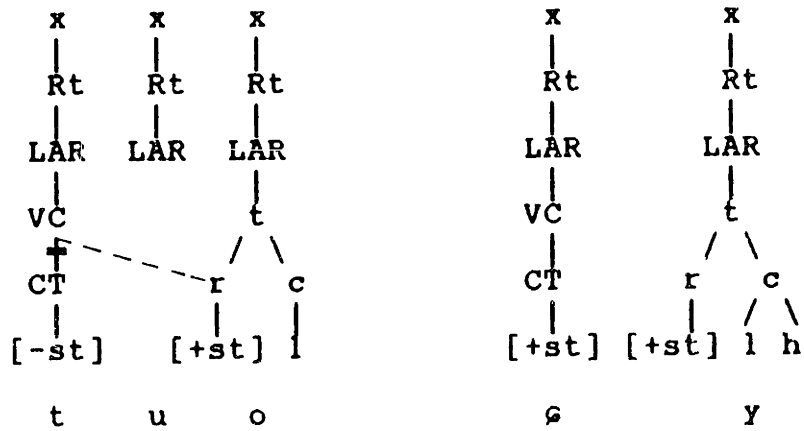

Tone in Phonological Representation

(55) Continuation of (50) əy ll ñu 213

Segmentalization

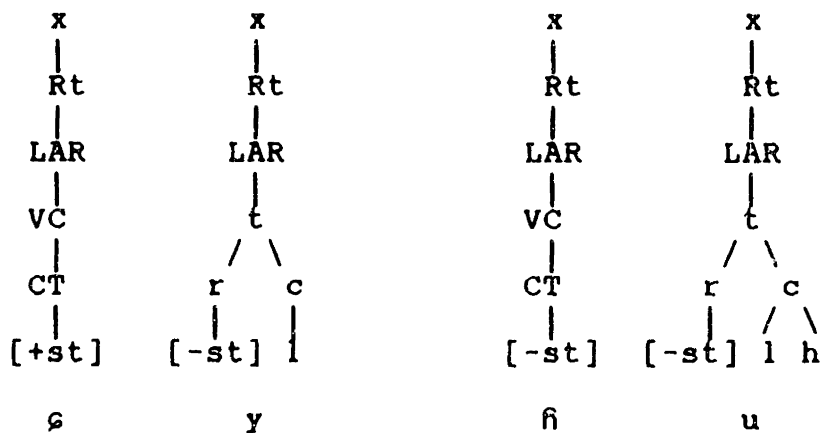

Voicing

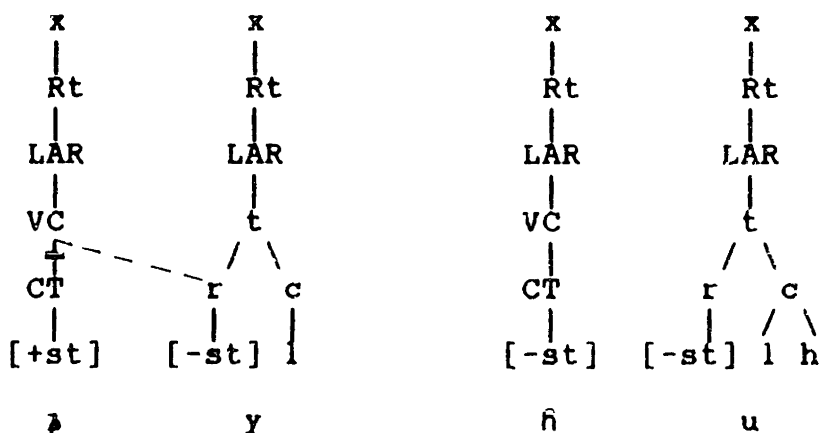

In (50), I only give the relevant details of the structure; the vowel's laryngeal node dominates t, which is intended to bring out the fact that it is the segmentalized tone. Note that in (50a) the glide is not specified for the VC node. The voicing and devoicing results from the same phonological process. Tonal registers influence onset segments.

5.4 Phonological Processes of Tone Sandhi

Clements (1989) lists eight what he calls elementary operations, which are reproduced below:

(56) Elementary Operations:

- | | |
|-----------------|---------------|
| a. spread X | b. delink X |
| c. insert X | d. delete X |
| e. break X | f. fuse X, Y |
| g. permute X, Y | h. map X to Y |

In tonal phonology, we have seen rules involving the elementary operations of spreading and delinking (as in contour assimilation), insertion (as in contour formation), deletion (as in the deletion of lexical tones), permutation (as in contour metathesis). Tone mapping, which involves the elementary operation of mapping, is interpreted as adjunction to a syllabic constituent. I have not been able to find unequivocal cases of tone fission (i.e. (56e)) and fusion (i.e. (56f)). In this section I will recapitulate the phonological processes which operate in tone sandhi by focusing on their formal properties. Specifically, I will discuss the formal properties of assimilation and dissimilation in contour systems. Due to the complexity of tonal geometry in a contour systems, these processes often manifest themselves in different ways, and a formal elucidation is called for.

Tone in Phonological Representation

5.4.1 Assimilation

We have seen four types of assimilation in tone sandhi: tone assimilation, register assimilation, contour assimilation and feature assimilation. They are exemplified as follows:

(57) a. Tone assimilation

Changzhi:

xæ təʔ "child"

24 535 > 24-24

b. Register assimilation

Pingyao:

xei tsue "river flood"

13 53 > 35 423

c. Contour assimilation

Weining Miao:

ku nu "oxen's horn"

55 35 > 55 55

d. Feature assimilation

Gao'an:

siu p'i "repair"

55 33 > 53 33

In terms of formal operations, tone, register and contour assimilation involves the simultaneous operation of spreading and delinking, while feature assimilation only

Tone in Phonological Representation

involves the elementary operation of spreading. Consider now the spreading operation involved in the assimilation cases enumerated in (57). They are shown in (58):

(58) a. Tone assimilation

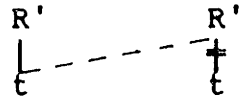

b. Register assimilation

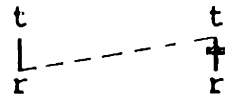

c. Contour assimilation

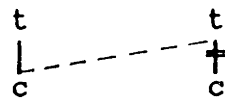

d. Feature assimilation

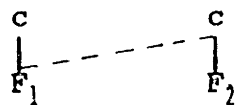

In (58a), (58b) and (58c) the target node must delink as a result of spreading. In (58d), spreading does not induce delinking of the target node. The first three instances of spreading involves non-terminal nodes, whereas the last instance of spreading involves terminal nodes. This property of assimilation can be attributed to the well-formedness condition which is motivated for segmental phonology as well. Sagey (1986:50) stipulates that only terminal nodes may branch (for a different approach to constraining

branching configuration of nodes, see Clements (1989)). The stipulation is stated as follows:

- (59) Contour segments may branch for terminal features only. No branching class nodes are allowed.

In addition to contour tones, contour segments include affricates and pre-nasalized stops. The tonal geometry I introduced satisfies the condition (59) since the branching nodes are the terminal feature [slack], dominated by the c node:

- (60)
- ```

 c
 / \
 [αslack] [-αslack]

```

Sagey (1986) gives the structures in (61) for affricates and pre-nasalized stops:

- (61) a. Affricates

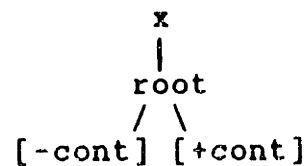

- b. Pre-nasalized stops

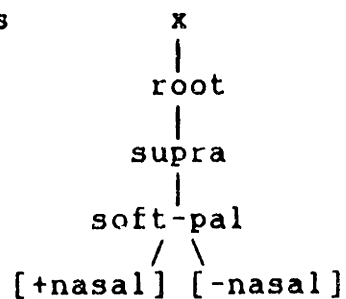

where *supra* is the supralaryngeal node, and *soft-pal* is the

soft palate articulator. Like contour tones, the sequence of terminal features is temporally significant: in affricates, [-continuant] must precede [+continuant] in time; and in pre-nasalized stops, [+nasal] must precede [-nasal]. Another property contour segments have in common is the fact that the contour in a contour segment can only be specified by a binary branching of the relevant features. No segment has the structure below:

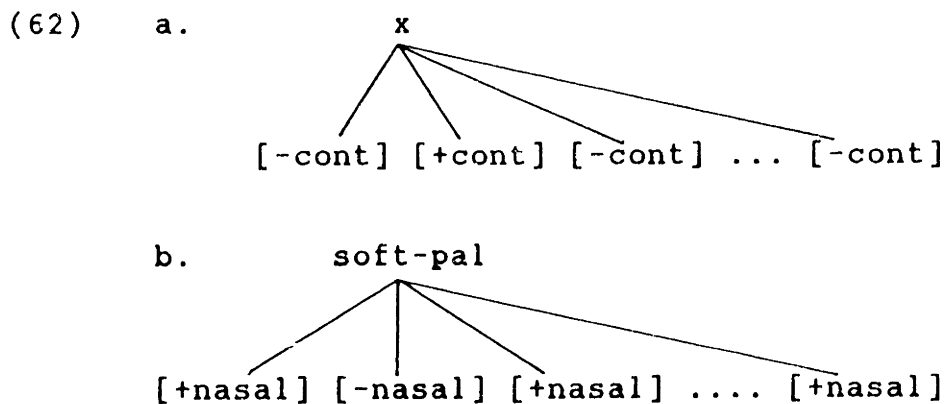

We need a supplemental constraint on the branching configuration, which I state as follows:

- (63) Only binary branching of terminal features is allowed

In §3.1 (6), Chapter Three, I stipulated that *c* nodes are binary. This can now be seen as a special case of the stipulation (63).

There is a major difference between contour tones and affricates. Segments with structures in (64a) do not occur

*Tone in Phonological Representation*

in natural languages, but contour tones may have either of the two structures in (64b):

- (64) a. 
$$\begin{array}{c} \text{root} \\ / \quad \backslash \\ [+cont] \quad [-cont] \end{array}$$
- b. 
$$\begin{array}{c} \text{c} \\ / \quad \backslash \\ [+slack] \quad [-slack] \end{array} ; \quad \begin{array}{c} \text{c} \\ / \quad \backslash \\ [-slack] \quad [+slack] \end{array}$$

In other words, the elementary operation of permutation is possible on contour tones, but not on affricates and pre-nasalized stops. When contours are permuted, the falling contour becomes rising, and the rising contour becomes falling. Such operation is behind the sandhi rule which I called contour metathesis. I will return to contour metathesis in §5.4.2.

Sagey's condition rules out structures in which a non-terminal node dominates two non-terminal nodes of the same type, but allows two non-terminal nodes of different types to be sisters under the same node:

- (65) a. inadmissible 
$$\begin{array}{c} \text{supra} \\ / \quad \backslash \\ \text{soft-pal} \quad \text{soft-pal} \\ | \quad | \\ [+nasal] \quad [-nasal] \end{array}$$
- b. admissible 
$$\begin{array}{c} \text{supra} \\ / \quad \backslash \\ \text{soft-pal} \quad \text{place} \end{array}$$

Tone in Phonological Representation

c. admissible

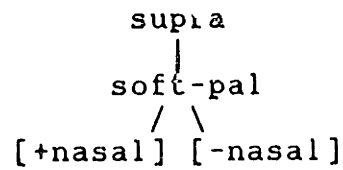

A branching class node is allowed as long as its daughters are not of the same type (65b). With respect to tone, the condition makes the following restrictions:<sup>15</sup>

(66) admissible

a.

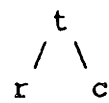

b.



inadmissible

c.

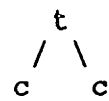

d.

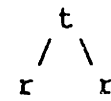

where F and F' are instances of [slack]. In (66a), the structure is admissible because the non-terminal node t dominates two non-terminal nodes of different types, r and c. The structures (66c,d) are not admissible because the t node dominates a sequence of two c nodes (66c) or a sequence of two r nodes (66d). The elementary operation of spreading involving the c node or r node creates precisely the ill-

---

15. A branching r node would be well-formed since it dominates two terminal nodes:

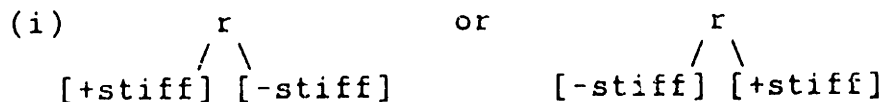

The two structures in (i) are ruled out conceptually: the tonal geometry expressly states that only the c node branches, cf. §3.1, Chapter Three.

formed structures (66c) and (66d). The well-formedness condition (59), however, does not include a repair strategy which will "prune" ill-formed trees to make them well-formed. A condition such as (65), proposed by Halle and Vergnaud (1982:80), is needed:

- (67) If the application of a rule results in a violation of the conditions -- either universal or language-specific -- which must be met by well-formed representations in the language in question, the violation is removed by deleting links between autosegments and core phonemes established by earlier rules or conventions.

Due to this condition, when spreading creates an ill-formed structure such as (66c,d), delinking is triggered automatically to remove the original autosegmental linkage. But if spreading involves features, creating the structure (66b), delinking is not invoked.<sup>16</sup> This property of

---

16. The Halle-Vergnaud convention is rewritten as the Branch Pruning Convention by Clements (1989):

Branch Pruning Convention

Given a branching configuration (5), remove the older of the two branches.

The configuration (5) is the No Branching Condition as follows,

- (5) No Branching Condition

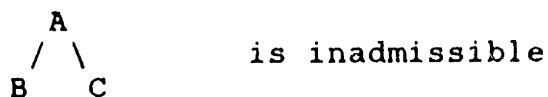

where A is a non-terminal node, B and C are either terminal or non-terminal. I adopt the Halle-Vergnaud condition

assimilation is observed not only in tonal assimilation, but in segmental assimilation as well. Place assimilation, for instance, necessarily induces the delinking of the target place node.<sup>17</sup>

To summarize, assimilation in tonal phonology has the following formal properties:

- (68) a. spreading and delinking, if the assimilating node is non-terminal
- b. spreading, if the assimilating node is terminal

I have shown that the properties of tonal assimilation

---

because the c node is ruled out as inadmissible by the No Branching Condition. This condition works only when B and C are non-terminal of the same type.

17. In fact, to satisfy Sagey's condition, either deletion or delinking will do. Both operations result in a singly linked non-terminal node:

- (i) Result of delinking

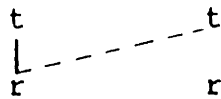

- Result of deletion

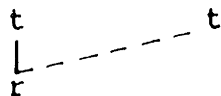

Delinking creates a floating tone, but deletion does not. A floating tone is not equivalent to a deleted tone, and some phonological phenomenon, notably downdrift, is triggered by the presence of a floating tone (cf. Pulleyblank (1986)). In this study, however, nothing hinges on whether illegal nodes are deleted or merely delinked.

follows from well-formedness condition of Sagey (1986) (in (59)) and the Halle-Vergnaud convention (in (65)).

5.4.2 Dissimilation

Given the tonal geometry in (69),

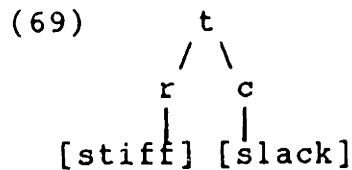

we predict three kinds of dissimilation. First, the non-branching specification of the c node may dissimilate; second, the register may dissimilate; and third, since the c node is possibly branching, the c node may dissimilate. These dissimilation cases are illustrated by the structures in (70):

(70) Contour dissimilation

a. Pingyao:

pu ta<sub>0</sub> "hatch an egg"

13 35 > 31-35

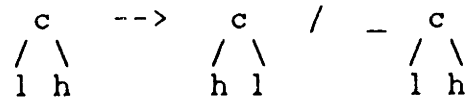



b. Tianjin:<sup>18</sup>

kau ʃan "high mountain"

21 21 > 213 21

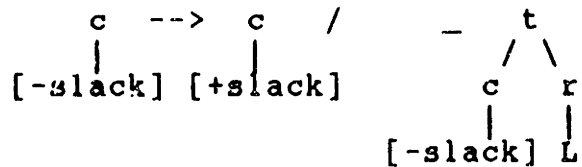

(71) Register dissimilation

Luoyang (W. He (1984)):

iaŋ ma "raise horses"  
 lo mi "old rice"

53 53 > 31 53

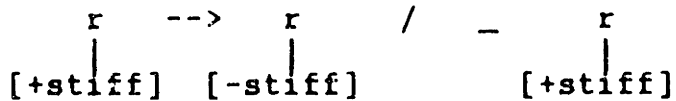

Dissimilation involving a branching c node is a simple case of the elementary operation of permutation, as (70a) shows. (70b) and (71) illustrate the same process of a feature-changing operation. This operation is not considered as elementary by Clements (1989), since it is not in the list in (56). Feature-changing operation may be considered as a composite of the elementary operations of deletion and insertion, as illustrated by register lowering in (72):

18. I assume that underlyingly Tianjin has only even tones, so the surface contours in the examples result from a feature-inserting rule which creates the contour of rising. For Tianjin data, see Li and Liu (1985), M. Chen (1986a), Hung (1987), Tan (1987) and Z.-S. Zhang (1987).

Tone in Phonological Representation

|           |   |          |          |   |
|-----------|---|----------|----------|---|
| (72)      | [ | r        | r        | ] |
|           |   |          |          |   |
|           |   | [+stiff] | [+stiff] |   |
| Deletion  | [ | r        | r        | ] |
|           |   |          |          |   |
|           |   |          | [+stiff] |   |
| Insertion | [ | r        | r        | ] |
|           |   |          |          |   |
|           |   | [-stiff] | [+stiff] |   |

In (72), the H register is first deleted; to be followed by the insertion of the L register. This view of feature-changing process is problematic; there is no principled way to guarantee that the feature being inserted can only be the deleted feature with a different value. I consider feature-changing operation as elementary.

5.4.3 Other Sandhi Effects

In addition to assimilation and dissimilation, we also find the following processes in tonal phonology:

(73) a. Contour Formation

Pingyao:

xei tsue "river flood"

13 53 > 35 423

|     |     |     |             |
|-----|-----|-----|-------------|
| r   | --> | t   | (insertion) |
| / \ |     | / \ |             |
| h l |     | hlh |             |

## Tone in Phonological Representation

### b. Contour Simplification

Xiamen:

bə 35 "no" > bə 55 cī 35 "no money"

35 > 33

$$\begin{array}{ccc} c & \text{-->} & c \\ / \quad \backslash & & | \\ l \quad h & & l \end{array} \quad \text{(deletion)}$$

### c. Feature-filling

Changzhi:

Default rules:

[ ] --> [-stiff]

[ ] --> [-slack]

$$\begin{array}{ccc} t & \text{-->} & t \\ / \quad \backslash & & / \quad \backslash \\ r \quad c & & r \quad c \\ & & | \quad | \\ & & [+stiff] \quad [+slack] \end{array} \quad \text{(insertion)}$$

The sandhi processes illustrated in (73) can be accounted for in terms of insertion, as in contour formation and feature-filling processes; and delinking (or deletion), as in contour simplification.

Chapter Six

The Mid Tone

The tone model introduced in Chapter Three makes available four even-contoured tones. They have the structures in (1):

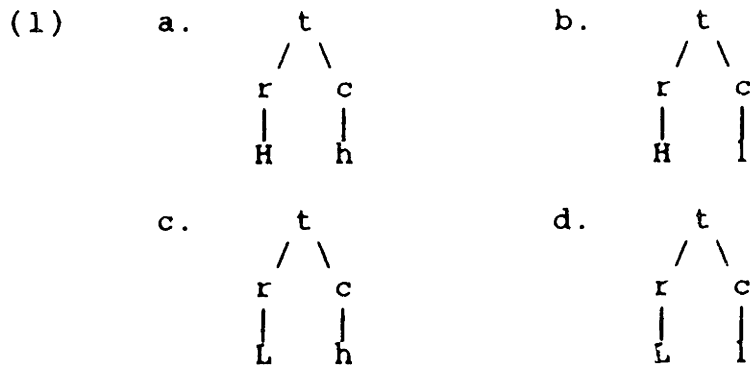

The two structures (1b) and (1c) formally encode tones which phonetically occupy the mid-range of the pitch scale - - the former being higher in pitch than the latter. In languages which make use of four even tones, all the structures in (1) surface as distinctive tones. However, in cases where there are fewer than four even tones there is a degree of indeterminacy concerning the structure of the mid tone. This state of affairs arises when we consider a tonal inventory such as (2):

(2)      55    33    11

We can assign the structure (1a) to 55, and (1d) to                      But

we have two structures available for the mid tone 33: it can be either [L,h] (1c) or [H,l] (1b). The indeterminacy can be resolved by its sandhi behavior. Suppose that R is a register-sensitive rule. If 55 and 33 undergo or trigger R but 11 does not, then 33 must be a H-registered tone; on the other hand, if 33 and 11 undergo or trigger R but 55 does not, we conclude that 33 is a L-registered tone.

The matter, however, is not so simple. For any given register, there are two possible c node specifications. Thus, if 33 is a H-registered tone, it necessarily differs in its c node specification from the other H-registered tone, 55. The c node of 33 is l; and that of 55 is h. 33 as [H,l] would fall in the same class as 11, which is [L,l], by virtue of the c node specification. 55 and 33 belong to the same class by virtue of their registers. The structural indeterminacy of the mid tone 33 often leads to different analyses of the same sandhi phenomenon. We saw in Chapter Three (§3.3.4) the sandhi phenomenon of Gao'an, whose conal inventory contains the three even tones in (2). Recall that in this language 55 becomes 53 when it precedes either 33 or 11. There are two analyses available, depending on the formulation of the sandhi rule and the assumption about the structure of the mid tone 33. Suppose that 33 has the structure (1c), namely [L,h]. 33 and 11 are L-registered tones. The 55>53 sandhi can be viewed as a case of contour

dissimilation: the even contour becomes the falling contour before another even-contoured tone. Formally this can be accounted for by the rule in (3):

$$(3) \quad \begin{array}{c} c \\ | \\ h \end{array} \quad \rightarrow \quad \begin{array}{c} c \\ / \quad \backslash \\ h \quad i \end{array} \quad / \quad \begin{array}{c} t \\ / \quad \backslash \\ r \quad - \\ | \\ H \end{array} \quad \begin{array}{c} t \\ / \quad \backslash \\ c \quad r \\ | \quad | \\ \quad L \end{array}$$

where the second c node is nonbranching (i.e. even contour). The formal significance of this rule is that it refers to the structural property of a nonbranching c node. The terminal nodes it dominates do not figure in the sandhi process.

Alternatively, we assume that 33 has the structure in (1b), [H,1]. 33 and 11 are both 1-contoured tones. The 55>53 sandhi can be viewed as an assimilatory spreading of [+slack]:

$$(4) \quad \begin{array}{c} [ \quad c \quad \quad \quad c \quad ] \\ | \quad \quad \quad \quad | \\ [-slack] \quad [+slack] \end{array}$$

The contour of the first tone becomes falling as a result of l-spreading. The two analyses of the Gao'an sandhi facts are equally plausible. Both are allowed by the theory developed in Chapter Three.

The Gao'an data show the theoretical possibility to analyze the same sandhi phenomenon differently depending on

the structure assumed for the mid even tone 33. Nonetheless, each analysis has a unique structure for the mid tone. In §3.4.3, we saw that the optimal analysis of the so-called Min Circle in Xiamen requires that the two structures [H,l] and [L,h] be realized as 33. Recall that Xiamen has two even tones 55 and 33. As part of the Min Circle, the high even tone 55 lowers to 33. There is a contour simplification process in the derivation of the Min Circle. The rising tone 35 simplifies to 33, and the falling tone 53 simplifies to 55. The 35>33 sandhi fact suggests a derivation of the 55>33 lowering in which [+slack] is first inserted to the c node of 55, yielding the rising tone 35; the rising contour is then simplified, yielding the mid even tone 33. In other words, the derivation process is 55>35>33. The derivation of the three sandhi effects are shown in (5):

- (5) a.  $\begin{array}{c} t \\ / \quad \backslash \\ r \quad c \\ | \quad | \\ H \quad h \end{array} \dashrightarrow \begin{array}{c} t \\ / \quad \backslash \\ r \quad c \\ | \quad / \quad \backslash \\ H \quad l \quad h \end{array} \dashrightarrow \begin{array}{c} t \\ / \quad \backslash \\ r \quad c \\ | \quad | \\ H \quad l \end{array} \quad (55>35>33)$
- b.  $\begin{array}{c} t \\ / \quad \backslash \\ r \quad c \\ | \quad / \quad \backslash \\ H \quad l \quad h \end{array} \dashrightarrow \begin{array}{c} t \\ / \quad \backslash \\ r \quad c \\ | \quad | \\ H \quad l \end{array} \quad (35>33)$
- c.  $\begin{array}{c} t \\ / \quad \backslash \\ r \quad c \\ | \quad / \quad \backslash \\ H \quad h \quad l \end{array} \dashrightarrow \begin{array}{c} t \\ / \quad \backslash \\ r \quad c \\ | \quad | \\ H \quad h \end{array} \quad (53>55)$

The output in (5) indicates that the mid even tone 33 has the structure [H,l] (cf. (5a,b)), which contrasts with [H,h] (cf. (5c)), the structure for the high even tone 55.

In addition to the sandhi effects shown in (5), we see in the Min Circle that the even tone 33 becomes the low falling tone 31. This can be accounted for by a single feature inserting rule if we assume that 33 has the structure [L,h]. The derivation is shown below:

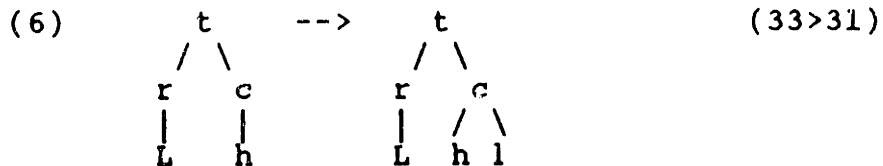

In other words, 33 has the underlying structure [L,h]; and l-insertion results in [L,hl], which is the structure for the low falling tone 31. The analysis of the Min Circle in Xiamen leads to the conclusion 33 is the phonetic manifestation of the two structures [H,l] and [L,h].

The Gao'an and Xiamen data demonstrate the dual status of the mid tone. In the case of Gao'an, the analysis of the sandhi facts depends on the structure assumed for the mid tone 33; in the Min Circle of Xiamen, the two structures [L,h] and [H,l], one underlying and the other derived, are neutralized phonetically. Such dual status is a consequence of the theory, which provides two representations for the phonetically mid tones. This property of the theory is



desirable. Take the Min Circle for example. If the theory does not allow dual characterization of the mid tone, we would need more rules to derive the surface facts of the Min Circle. By shifting the burden from rule to representation, we are able to account for the facts with less use of phonological rule.

This theoretical possibility is further supported by empirical facts concerning the mid tone from Weining Miao, which we first saw in §3.2. Weining Miao has seven tones in citation form, as in (7) (F.-S. Wang (1957); see Appendix for the sound system of the language):

- |     |       |             |       |             |
|-----|-------|-------------|-------|-------------|
| (7) | a. 55 | ku "I"      | b. 33 | ko "root"   |
|     |       |             | c. 11 | ku "be"     |
|     | d. 53 | ly "willow" | e. 31 | la "friend" |
|     | f. 35 | v'ae "that" | g. 13 | v'ae "grab" |

The tones in Weining Miao do not show the effect of syllable-initial consonants. This can be seen in the pairs (7a,c) and (7f,g). The voiceless velar stop /k/ is used with the high even tone 55, the mid event tone 33, and the low even tone 11. Similarly, the voiced aspirated fricative /v'/ is used with both the high and low rising tones. We can not reduce the number of underlying tones on account of the voicing qualities of syllable-initial segments. The tones have the structures in (8):

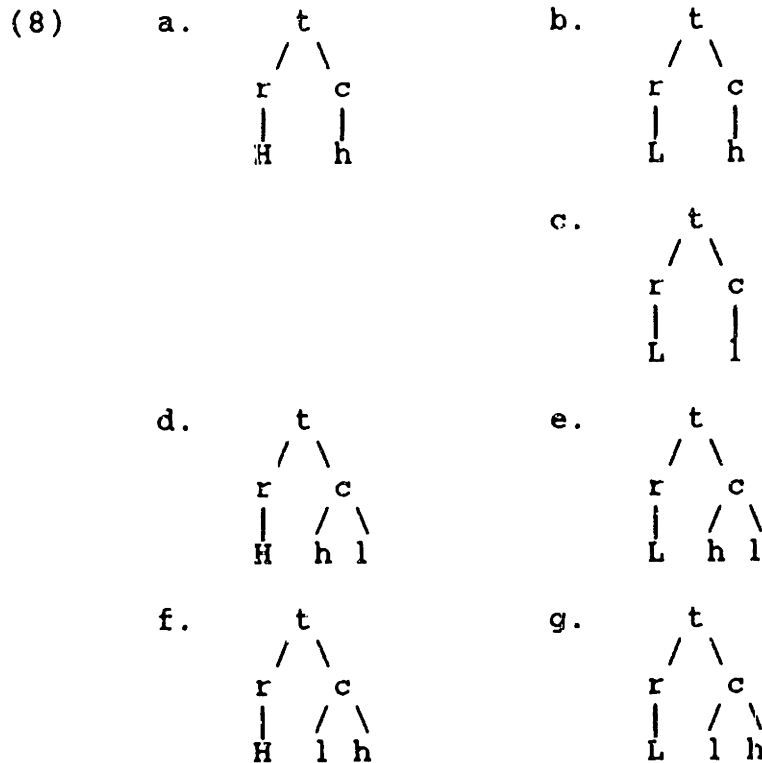

The mid even tone 33 is represented in (8) as [L,h]. Weining Miao has all the theoretically possible tones, except the missing structure in (9):

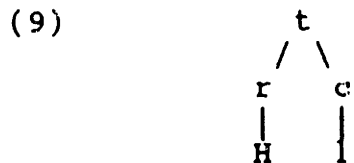

I will argue that the optimal analysis of the sandhi behavior observed in numerals and classifiers in the language leads us to conclude that (9) is the derived structure which surfaces as the mid tone 33. The mid tone is therefore the surface manifestation of two structures, (8b) and (9). Weining Miao's tonal inventory contains all the

theoretically possible tonal contrasts.

The sandhi process which affects the numerals and classifiers in the language has the following general property:

- (10) In numerals,
- a. The mid even tone 33 lowers to the low even tone 11 when the preceding tone is H-registered;
  - b. the low falling tone 31 becomes the low rising tone 13 when the preceding tone is H-registered.

In numeral+classifier phrases,

- c. the high even tone 55 and the mid even tone lower to 33 and 11 respectively, when the preceding tone is H-registered.
- d. The mid even tone 33 does not trigger the sandhi phenomena observed in (a,b,c).

(The classifiers which exhibit the sandhi behavior (10c) belong to the categories II and IV; see §6.2 for details.) The mid even tone 33 and the high even tone 55 exhibit the same sandhi behavior as an undergoer of the lowering process (10a,c); but 33 differs from 55 and other H-registered tones in that it does not trigger the lowering process. In this regard, 33 behaves like a L-registered tone. Details of the sandhi data in Weining Miao's numeral and classifier system and their analysis follow. All Weining Miao data are taken from F.-S. Wang (1957).

## 6.1 The Numerals

The number system in Weining Miao is strictly decimal.

The numbers one through ten are in (11):

|      |                    |         |             |         |
|------|--------------------|---------|-------------|---------|
| (11) | i 55               | "one"   | a 55; ni 31 | "two"   |
|      | ts <sub>1</sub> 33 | "three" | tlau 55     | "four"  |
|      | pw 55              | "five"  | tlau 33     | "six"   |
|      | ɣaw 33             | "seven" | ʃ'i 31      | "eight" |
|      | dʒ'a 35            | "nine"  | g'au 31     | "ten"   |

The tone of g'au 31 "ten" changes to 13 when it is preceded by a H-registered tone, as the data below show:

|      |    |                       |          |
|------|----|-----------------------|----------|
| (12) | a. | ni ng'au              | "twenty" |
|      |    | 21 31 > 21 31         |          |
|      | b. | ts <sub>1</sub> dʒ'au | "thirty" |
|      |    | 55 31 > 55 13         |          |
|      | c. | pw dʒ'au              | "fifty"  |
|      |    | 55 31 > 55 13         |          |
|      | d. | dʒ'a dʒ'au            | "ninety" |
|      |    | 35 31 > 35 13         |          |
|      | e. | ʃ'i dʒ'au             | "eighty" |
|      |    | 31 31 > 31 31         |          |

(The voiced, aspirated velar obstruent /g'/ changes to the prenasalized, aspirated velar stop /ng/ when preceded by ni (12a), and /dʒ'/ otherwise.) The 31>13 sandhi can be captured by the contour metathesis rule formulated in (13):

(13) Contour Metathesis

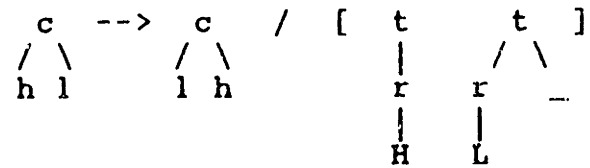

The rule is triggered by the preceding H register. The mid even tone 33 does not trigger Contour Metathesis:

- (14) a. tɬau dɬ'au "sixty"  
           33 31 > 33 31
- b. ɕaw dɬ'au "seventy"  
           33 31 > 33 31

Thus, 33 behaves as if it is a L-registered tone, having the structure in (8b).

The unit number ts'ie 55 "thousand" does not exhibit any sandhi effects: i 55 ts'ie 55 "one thousand." The unit number vau 53 "ten thousand" has similar sandhi behavior as g'au 31 "ten." The data are shown below:

- (15) a. i vau "10,000"  
           55 53 > 55 13 (-v'au)
- b. dɬ'a vau "90,000"  
           35 53 > 35 13 (-v'au)
- c. pi dɬau vau "tens of thousands"  
           55 53 53 > 55 53 13 (-v'au)
- d. tɬau vau "60,000"  
           33 53 > 33 31 (-v'au)

- e.    ts<sub>1</sub> d<sub>ɓ</sub>'au vau            "300,000"  
        33 31 53 > 33 13 31
- f.    i pa vau                    "1,000,000"  
        55 33 53 > 55 11 31 (-v'au)

(As a result of tone sandhi the initial obstruent of vau becomes aspirated.) As we can see, the tone for the word vau is 31 if the preceding tone is L-registered (15d,e,f); but 13 if the preceding tone is H-registered (15a,b,c). This suggests that the high falling tone 53 in citation form is not the underlying tone; the low falling tone 31 is. The citation tone 53 can be derived by a L>H raising rule which applies to numerals in citation form. Contour Metathesis derives the tone patterns observed in (15).<sup>2</sup> Note again that 33 does not trigger Contour Metathesis (cf. (15d)).

The word van 53 "ten thousand" has some idiosyncratic sandhi patterns. If it is preceded by a single lexical tone 31, Contour Metathesis applies as well (16a); but if it is preceded by the sequence 33 31, Contour Metathesis is blocked (16b) (I give 31 as the tone of vau, instead of 53):

---

2. If 31 is the underlying tone for vau, underlyingly the initial obstruent [v] must also be aspirated. The derivation of the citation form vau 53 involves raising the register and de-aspirating the initial obstruent.

- (16) a.    ʔ'i vau                    "80,000"  
           31 31 > 31 13 (-v'au)
- b.    tlau dʔ'au vau            "600,000"  
           33 31 31 > 33 31 31 (-v'au) <sup>3</sup>

(16b) is the expected result; (16a) is not. I take this to be a lexical idiosyncrasy of the word vau 53 "ten thousand."

In (15f), the unit pa 33 "hundred" lowers to pa 11 when it follows a 55 tone. More data concerning the word follow:

- (17) a.    a pa                        "200"  
           55 33 > 55 11
- b.    dʔ'a pa                       "900"  
           35 33 > 35 11
- c.    pi dʒau pa                    "several hundred"  
           55 53 33 > 55 53 11
- d.    ʔ'i pa                        "800"  
           31 33 > 31 33
- e.    tlau pa                        "600"  
           33 33 > 33 33
- f.    ʔaw pa                       "700"  
           33 33 > 33 33

---

3. F.-S. Wang (1957:77) gives 11 31 31 as the tone pattern for "600,000." The pattern shows the lowering of the phrase-initial tone 33 to 11. I do not use this form for two reasons: First, 33 does not lower to 11 in this position elsewhere, cf. (14); secondly, it is not crucial for the purpose at hand.

The Mid Tone

Descriptively the mid even tone 33 lowers to the low even tone 11. Like Contour Metathesis, the 33>11 lowering is triggered by the preceding H-registered tone (17a,b,c), but not L-registered tones (17d). Again, 33 does not trigger the lowering (17e,f). With respect to contour metathesis and lowering, 33 behaves like a L-registered tone. Given the structure [L,h] (cf. (1b)), the lowering process can be formally captured by the rule in (18):

(18) C-lowering

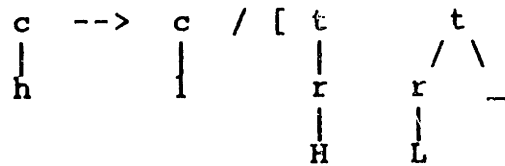

The rule derives [L,l] (i.e. 11) from [L,h] (i.e. 33). In the number system of Weining, H-registered tones trigger sandhi processes which involve the c node, namely Contour Metathesis and C-lowering.

Alternatively, we can view the 33>11 sandhi as a case of register dissimilation. Given the structure in (19a) we can formulate the rule in (19b), which lowers the register from H to L:

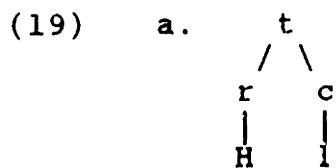



## b. R-lowering

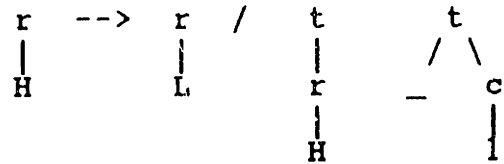

The two lowering rules, C-lowering in (18) and R-lowering in (19b), are comparable in terms of formal complexity; both are rules which change feature values. Despite that fact that they are able to derive the 33>11 sandhi, the two rules have different empirical consequences. Since the C-lowering analysis assigns [L,h] as the structure of 33,<sup>3</sup> it provides a ready explanation for the fact that the mid-even tone 33 does not trigger Contour Metathesis or C-lowering. The R-lowering analysis fails to capture this fact. Since 33 has the structure [H,l], the R-lowering analysis predicts that 33 would trigger Contour Metathesis or C-lowering, just like as other H-registered tones. This prediction is not correct. The sandhi facts of the numerals appear to support the C-lowering analysis.

We now turn to the sandhi phenomenon of the classifiers.

---

3. I will call the analysis which postulates the C-lowering rule as the C-lowering analysis; and the analysis which postulate the R-lowering rule as the R-lowering analysis.

## 6.2 The Classifiers

F.-S. Wang (1957:78) groups the classifiers into seven categories, depending on their initial consonants and tones. The seven categories are as follows:

## (20) Categories Attributes

|     |                                    |
|-----|------------------------------------|
| I   | voiceless initials; high even tone |
| II  | voiced initials; high rising tone  |
| III | voiceless initials; high even tone |
| IV  | voiceless initials; mid even tone  |
| V   | voiced initials; mid even tone     |
| VI  | voiced initials; high falling tone |
| VII | voiced initials; high even tone    |

Note that classifiers with voiceless initials and the high even tones fall into two categories, (20I) and (20III). The difference between them is their sandhi behavior. The high even tone exhibits tone sandhi effect in Category (20I); but not in Category (20III). In fact this is the only criterion used by Wang for deciding the category of a classifier with a voiceless initial and the high even tone. Some classifiers are shown in (21) (F.-S. Wang (1957:113-118)):

|      |    |       |                      |                     |
|------|----|-------|----------------------|---------------------|
| (21) | a. | 55    | faw                  | for plants          |
|      |    |       | so                   | for bee hives, etc. |
|      |    |       | tɛ                   | for flowers; leaves |
|      |    |       | nts <sub>1</sub>     | slice               |
| b.   | 35 | dz'o  | for ropes, etc.      |                     |
|      |    | nd'aw | section (as of rope) |                     |

The Mid Tone

|    |    |     |                    |
|----|----|-----|--------------------|
| c. | 33 | lo  | for sentences      |
|    |    | ti  | layer              |
|    |    | baw | for rivers         |
|    |    | mw  | litter (of pigs)   |
|    |    | di  | handful            |
| d. | 53 | zae | pair               |
|    |    | ʔi  | family (of people) |
|    |    | dla | for books; letters |

No classifier has the tone 11, 31, or 13. If the mid even tone 33 is H-registered, the distribution of tones among the classifiers can be stated as follows:

(22) Tones of classifiers are H-registered

However, we saw in §6.1 that the rule of C-lowering in numerals is triggered by H-registered tones, and 33 does not trigger the lowering process. This means that 33 is L-registered. Therefore the proposition in (22) is not compatible with the conclusion we were led to make with respect to the sandhi behavior of the mid even tone in numerals.

The sandhi behavior of the mid even tone is also observed in the classifiers. The phrases under consideration has the form Numeral+Classifier+Noun. The tone sandhi patterns of classifiers of the categories (20III) and (20IV) are given in (23) (the horizontal axis represents tones of the numerals; and the vertical axis, tones of the

classifiers):<sup>5</sup>

| (23)   | a  | b  | c  | d  | e  | f  | g  | h     | i    |
|--------|----|----|----|----|----|----|----|-------|------|
|        | 55 | 33 | 31 | 35 | 13 | 11 | 53 | 33-31 | x-55 |
| III 55 | 33 | 55 | 55 | 33 | 55 | 55 | 33 | 55    | 33   |
| IV 33  | 11 | 33 | 33 | 11 | 33 | 33 | 11 | 33    | 11   |

We observe that when the preceding numeral has a H-registered tone, 55 lowers to 33 and 33 lowers to 11 (Columns (23a,d,g,i)). No lowering takes place when the preceding tone is L-registered (Columns (23c,e,f,h)). The mid even tone 33 does not trigger lowering either (Column (23b)), indicating that 33 is a L-registered tone. Relevant data are given in (24):

|      |    |               |           |
|------|----|---------------|-----------|
| (24) | a. | a tɕaw        | two kinds |
|      |    | 2 CL          |           |
|      |    | 55 55 > 55 33 |           |

5. Other tonal combinations also show sandhi effects; the complete table of tone sandhi in the numeral+classifier system in Weining Miao is reproduced in the Appendix. Note that in Columns (23h,i) two tones of the numerals are listed as the trigger of C-lowering. The effect of this is not obvious in the sandhi patterns of Categories III and IV classifiers, since 33-31 does not trigger lowering, and x-55 does, as expected. In Category V classifiers, the mid even tone 33 becomes 13, and the initial obstruent of the classifier is aspirated, when the preceding numeral has the tone 31; it becomes 31 when the preceding numerals have the tone sequence 33-31. Therefore it not sufficient to refer to the immediately preceding tone to handle the sandhi behavior of Category V classifiers.

- b.    ts<sub>1</sub> tə                    three (flowers)  
        3    CL
- 55 55 > 55 33
- c.    ts<sub>1</sub> tso so                three threads  
        3    CL
- 55 33 55 > 55 11 55
- d.    ɣaw tso                    seven pieces  
        7    CL
- 33 33 > 33 33
- e.    i ts'ae nG'ae            one piece of meat  
        1 CL        meat
- 55 33 35 > 55 11 35

I am not able to find more examples in F.-S. Wang's corpus of data. The tone sandhi effects in (23) as exemplified in (24) take place in numeral+classifier phrases only. In other types of phrase 55 and 33 are not lowered, as the following examples show:

- (25) a.    n'au ts'ae nG'ae  
           eat CL        meat  
           eat the piece of meat
- 35 33 35 > 35 33 35
- b.    ti lw ni  
           few CL this  
           these (people)
- 55 55 55 > 55 55 55

In (25a), 33 does not lower to 11 even though it follows a H-registered tone 35; and in (25b) the high even tone 55 does not lower to 33 following another 55. Both the high

The Mid Tone

rising tone 35 and the high even tone 55 trigger lowering on the following even tones in numeral+classifier phrases.

In §6.1 we saw that the mid tone 33 of the numeral pa 33 "hundred" lowers to 11 when it follows a H-registered tone (cf. (17)). We noted that the 33>11 sandhi can be accounted in terms of the C-lowering (cf. (18)) if we assign the structure [L,h] to the mid even tone, or R-lowering (19b) if we assign the structure [H,l]. Both rules derive [L,l] (i.e. 11) from their respective input structures. In the numeral+classifier construction, the mid even tone 33 lowers in the same tonal environment. Thus, the lowering process observed in numeral+classifier phrases is the same process which can be observed in the numerals. Again, we have two possible analyses, the C-lowering analysis and the R-lowering analysis. Both rules need to be modified to accommodate the lowering of 55:

- (26) a. C-lowering
- $$\begin{array}{cccc}
 c & \text{-->} & c & / & t & t \\
 | & & | & & | & | \\
 h & & l & & r & - \\
 & & & & | & \\
 & & & & H & 
 \end{array}$$
- b. R-lowering
- $$\begin{array}{cccc}
 r & \text{-->} & r & / & t & t \\
 | & & | & & | & / \quad \backslash \\
 H & & L & & r & c & - \\
 & & & & | & | & \\
 & & & & H & & 
 \end{array}$$

where the c node of the second tone (that of the classifiers) in the formulation of R-lowering (26b) is non-

branching. Formally C-lowering is not as complex as R-lowering since the latter rule must refer to the c node as well. In the formulation of C-lowering, the r node is superfluous. Due to its formal simplicity, the C-lowering analysis is to be preferred.

To be sure, both analyses derive the sandhi effects correctly from the underlying structures assumed for the tones in question. The derivation is shown below:

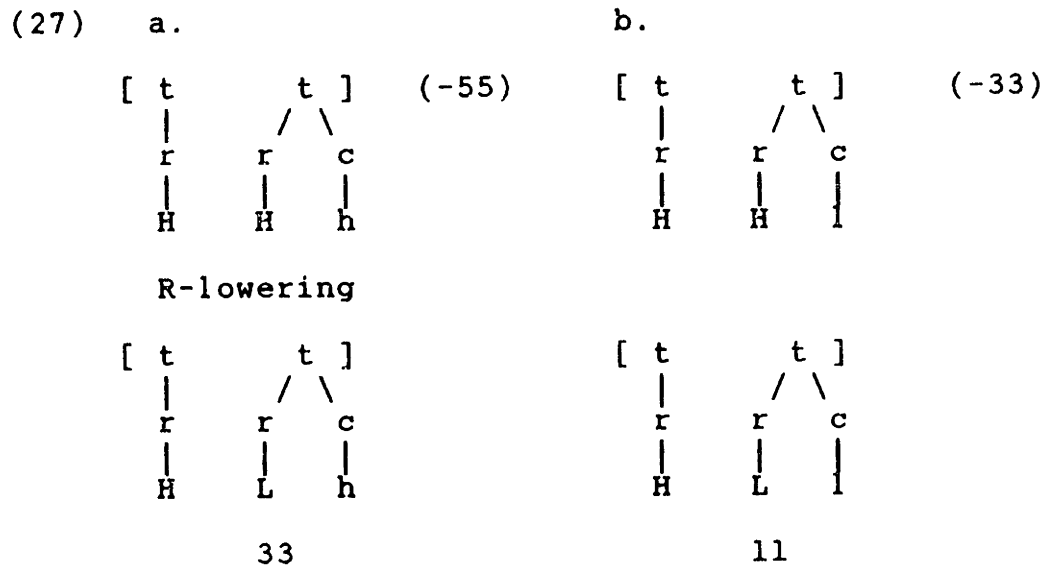

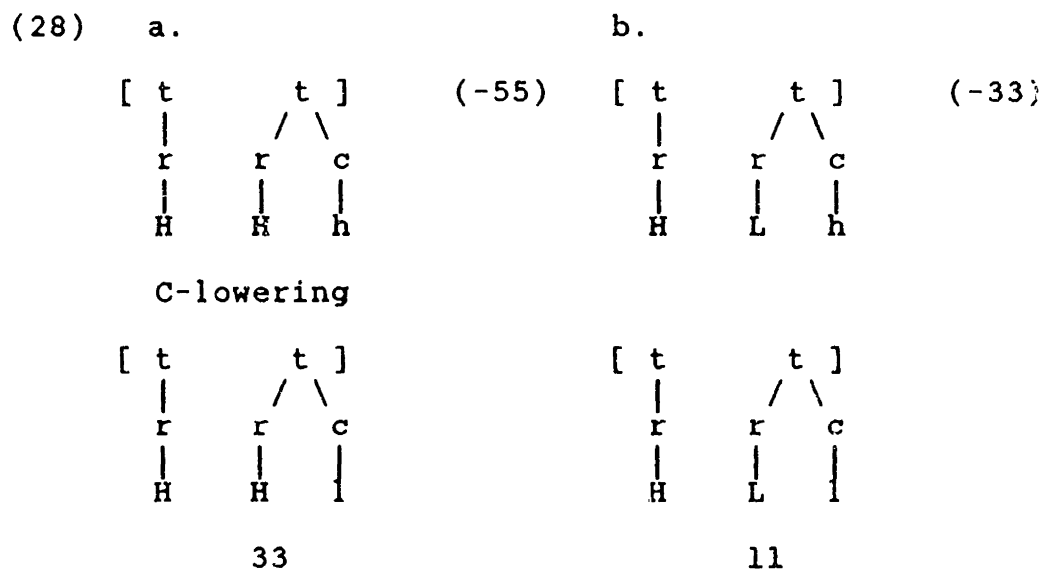

(The first tone is only specified for the H register.) In the R-lowering analysis (27), 33 is the phonetic realization of [H,l] and [L,h]; [H,l] being the underlying structure (cf. (27b)), and [L,h] the derived structure (cf. (27a)). In the C-lowering analysis (28), [H,l] and [L,h] are also neutralized phonetically to 33; but in this case [L,h] is the underlying structure (cf. 28b)), and [H,l] derived (cf. (28a)). As a result of the structures they postulate for the mid even tone, the two analyses make different empirical predictions. In the R-lowering analysis, the mid even tone 33 is H-registered; it therefore predicts that when a numeral with the tone 33 precedes a Category III or Category IV classifier, it would trigger lowering. But we have seen that 33 does not trigger lowering. Thus, *ɕaw 33 tso 33* "seven pieces (thread)" (cf. (24d)) does not surface as \**ɕaw 33 tso 11*. But the R-lowering analysis predicts otherwise:



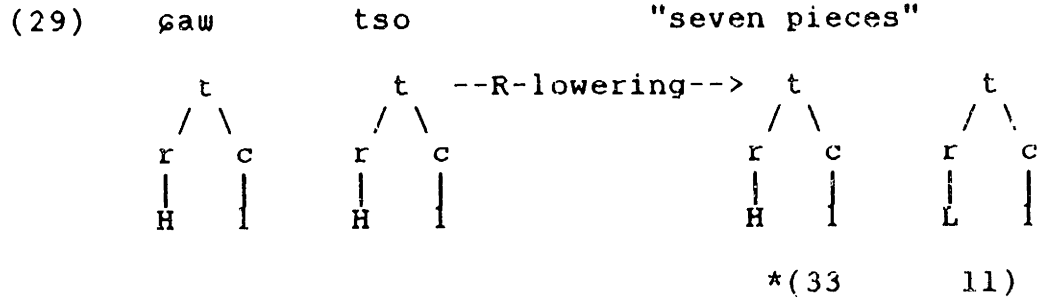

The C-lowering analysis makes the right prediction. The underlying structure for the mid even tone is [L,h], therefore it does not trigger lowering. However, the proposition stated in (22) can not be maintained. It is seen as an accidental fact about Weining Miao that no classifier has the tone 13, 31 or 11.

### 6.3 R-lowering Re-considered

The tone sandhi facts which need to be captured are summarized below:

- (30) In numerals,
- a. 31 metathesizes to 13 when it follows 55, 35, 53
  - b. 33 lowers to 11 when it follows 55, 35, 53
- In numeral+classifier phrases,
- c. 55 lowers to 33 when it follows 55, 35, 53
  - d. 33 lowers to 11 when it follows 55, 35, 53
  - e. classifiers only have 53, 35, 53, 33

The trigger of contour metathesis (30a) and lowering (30b,c,d) is a preceding H-registered tone. Our focus will be on lowering, namely the sandhi behavior of 55 and 33,

particularly the latter. The peculiar behavior of the mid even tone 33 is that it does not serve as a trigger, suggesting that it is a L-registered tone; yet it undergoes lowering in the same environment as the H-registered even tone 55, suggesting that it is a H-registered tone. The apparently contradictory behavior can be attributed to the possibility of characterizing the mid even tone as either [H,l] or [L,h].

Intuitively, the lowering involving 55 and 33 is a case of register dissimilation, since lowering only occurs when the preceding tone is H-registered. The R-lowering analysis is therefore more intuitively appealing than the C-lowering analysis. In numeral+classifier phrases, the R-lowering analysis is the preferred analysis. This is so because, by assuming that the mid even tone we see in classifiers has the structure [H,l], we are not only able to account for the lowering by R-lowering (19b), repeated below,

(19) b. R-lowering

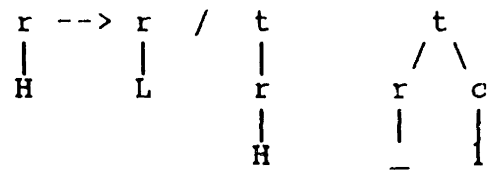

but also the generalization (22) (cf. (30e)). The assumption that the mid even tone in classifiers is H-registered can not be tested, since a classifier does not precede another

classifier, which would enable us to see whether the first 33 triggers the second 33 to lower. A sequence of two 33s can not come from a sequence of two classifiers. In numeral+classifier phrases, if both the numeral and the classifier have the tone 33, the second 33 does not undergo R-lowering. This will then force us to assume that the mid even tone in the numerals is L-registered; namely it has the structure [L,h]. If so, we have to use C-lowering to derive the 33>11 tone sandhi in numerals. This is the consequence which threatens the plausibility of the R-lowering analysis, as I pointed out in §6.2. The 33>11 tone sandhi is exactly the same phenomenon in numerals as in numeral+classifier phrases. It would thus be natural to assume that the same phonological process is responsible for it.

To provide a unified account of the tone lowering phenomenon in numerals as well as in numeral+classifier phrases, let us suppose that classifiers which surface in the mid even tone 33 have underlyingly the tone [H,l]; and the numerals which surface with the mid even tone 33 are underlyingly unspecified for tone. The following rule assigns either [H,l] or [L,h] prior to R-lowering (Num=numeral), depending on the environment:

(31) Tone Assignment

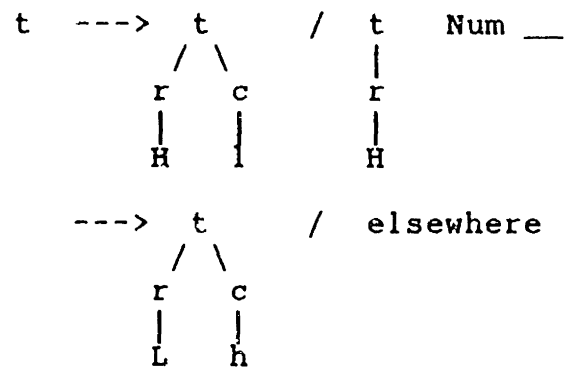

This rule assigns [H,l] to a toneless numeral just in case it follows a H-registered tone. R-lowering then applies.

Sample derivations of numerals follow:

(32) a. a pa "200" (17a)

[H,h]

Tone Assignment (31)

[H,h] [H,l]

R-lowering (19b)

[H,h] [L,l]

(55 ll)

b. dɔ'a pa "900" (17b)

[H,lh]

Tone Assignment (31)

[H,lh] [H,L]

R-lowering (19b)

[H,lh] [L,L]

(35 ll)

The Mid Tone

d. tlau pa "600" (17e)

Tone Assignment (31)

[L,h] [L,h]

(33 33)

The following are the derivations of some of the tone patterns of numeral+classifier phrases:

(33) a. ts<sub>1</sub> tø "3 (flowers)" (24b)

[H,h] [H,h]

Tone Assignment (31) Not Applicable

R-lowering (19b)

[H,h] [L,h]

(55 33)

b. ts<sub>1</sub> tso so "3 pieces of thread" (24c)

[H,h] [H,l] [H,h]

Tone Assignment (31) Not Applicable

R-lowering (19b)

[H,h] [L,l] [H,h]

(55 33 55)

c. saw tso "7 pieces" (24d)

[H,l]

Tone Assignment (31)

[L,h] [H,l]

R-lowering (19b) Not Applicable

(33 33)

The Mid Tone

d. i ts'ae nG'ae "1 piece of meat" (24e)  
[H,h] [H,l] [H,lh]  
Tone Assignment (31) Not Applicable  
R-lowering (19b)  
[H,h] [L,l] [H,lh]  
(55 11 35)

With the assumption that the mid even tone is unspecified in numerals, the R-lowering analysis is able to capture all the facts enumerated in (30) in an intuitively appealing way. The lowering process involving the two even tones 55 and 33 is a simple case of register dissimilation.

**Appendix: Sound Systems of Selected Languages**

**Contents**

|                       |     |
|-----------------------|-----|
| 1. Bai .....          | 312 |
| 2. Danyang .....      | 313 |
| 3. Changzhi .....     | 314 |
| 4. Gao'an .....       | 315 |
| 5. Pingyao .....      | 316 |
| 6. Songjiang .....    | 317 |
| 7. Weining Miao ..... | 319 |
| 8. Wenzhou .....      | 322 |
| 9. Wuyi .....         | 323 |
| 10. Xiamen .....      | 325 |
| 11. Zhenjiang .....   | 325 |

## 1. Bai (L. Xu and Y.-S. Zhao (1964))

## Initials

|    |     |   |   |   |
|----|-----|---|---|---|
| p  | ph  | m |   |   |
|    |     |   | f | v |
| t  | th  | n |   | l |
| ts | tsh |   | s |   |
| tɕ | tɕh |   | ɕ | j |
| k  | kh  | ŋ | x | ɣ |

## Finals

|      |        |        |
|------|--------|--------|
| i, ĭ | ao     | ui, uĭ |
| e, ě |        |        |
| ɛ, ĕ | iɛ, iĕ | ue, uĕ |
| a, ǎ | ia, iǎ | ua, uǎ |
| o, ǒ | io, iǒ |        |
| u    |        |        |
| w, ũ | iw, iŭ |        |
| ɤ, ǥ |        |        |

|       |       |    |    |    |    |
|-------|-------|----|----|----|----|
| Tones | Lax   | 33 | 31 | 55 | 35 |
|       | Tense | 42 | 44 | 21 | 55 |



## 2. Danyang (S.-X. Lü (1980))

## Initials

|    |     |   |   |   |
|----|-----|---|---|---|
| p  | p'  | m | f | v |
| t  | t'  | n |   | l |
| ts | ts' |   | s | z |
| tɕ | tɕ' | ɲ | ʂ |   |
| k  | k'  | ŋ | x |   |

In addition, Danyang has the zero-initial.

## Finals

|    |      |     |      |
|----|------|-----|------|
| ɿ  | i, I | u   | y, Y |
| a  | ia   | ua  | ya   |
| æ  |      | uæ  | yæ   |
| e  | ie   | ue  | ye   |
| ə  |      |     |      |
| ɔ  | iɔ   |     |      |
| ɔ̃ | iɔ̃  |     | yõ  |
| aɔ | iaɔ  | uaɔ | yaɔ  |
| eɔ | ieɔ  | ueɔ | yeɔ  |
| ɔ̃ | iɔ̃  |     |      |
| oɔ |      |     |      |
|    | iʔ   |     | yʔ   |
| aʔ | iaʔ  | uaʔ | yaʔ  |
| æʔ | iæʔ  | uæʔ | yæʔ  |
| ɔʔ | iɔʔ  |     |      |

Appendix

|       |    |    |    |   |   |
|-------|----|----|----|---|---|
| Tones | 55 | 33 | 11 | 4 | 3 |
|       | 24 |    |    |   |   |

3. Changzhi (J.-Y. Hou (1983))

Initials

|    |     |   |   |   |
|----|-----|---|---|---|
| p  | p'  | m | f | l |
| t  | t'  | n |   |   |
| ts | ts' |   | s |   |
| tʃ | tʃ' |   | ʃ |   |
| k  | k'  |   | x | 0 |

Finals

|    |     |     |     |
|----|-----|-----|-----|
| a  | ia  | ua  |     |
| ə  | iE  | ue  | yE  |
| ɪ  | i   | u   | y   |
| æ  |     | uæ  |     |
| ɔ  | io  |     |     |
| ei |     | uei |     |
| eu | iəu |     |     |
| aŋ | iaŋ | uaŋ | yaŋ |
| əŋ | iŋ  | uŋ  | yŋ  |
| aʔ | iaʔ | uaʔ | yaʔ |
| əʔ | iəʔ | ueʔ | yəʔ |

|       |     |    |    |           |
|-------|-----|----|----|-----------|
| Tones | 213 | 24 | 44 | 53        |
|       | 535 |    |    | <u>54</u> |

## 4. Gao'an (S. Yan (1981))

## Initials

|    |     |   |   |
|----|-----|---|---|
| p  | p'  | m | f |
| t  | t'  | l |   |
| ts | ts' | s |   |
| tʃ | tʃ' | ʃ |   |
| k  | k'  | ŋ | h |
| 0  |     |   |   |

## Finals

|    |    |     |    |     |     |     |     |     |     |     |
|----|----|-----|----|-----|-----|-----|-----|-----|-----|-----|
| a  | o  | ɛ   | i  | u   | y   | ai  | ɛi  | au  | ou  | eu  |
| ua | uo | ue  | ui |     |     | uai | uei |     |     |     |
| ia | io | iɛ  |    | iu  |     |     |     |     |     | ieu |
| am | om | ɛm  |    | an  | on  | ɛn  | ən  | aŋ  | oŋ  |     |
|    |    |     |    | uan |     | uen | un  | uaŋ | uoŋ | uŋ  |
|    |    | iɛm | im | ian |     | iɛn | in  | iaŋ | ioŋ | iŋ  |
|    |    |     |    |     | yon |     | yn  |     |     |     |
| ap | op | ɛp  |    | at  | ot  | ɛt  | ət  | ak  | ok  |     |
|    |    |     |    | uat |     | uet | ut  | uak | uok | uk  |
|    |    | iɛp | ip | iat |     | iɛt | it  | iak | iok | iuk |
|    |    |     |    |     | yot |     | yt  |     |     |     |

Note: Gao'an has three syllabic nasals [m, n ŋ] as well.

Tones        55    33    11    3    1  
               24    42

## 5. Pingyao (J.-Y. Hou (1980))

## Initials

|    |     |    |   |   |
|----|-----|----|---|---|
| p  | p'  | m  |   |   |
| t  | t'  | n  |   | l |
| ts | ts' | nz | s | z |
| tʃ | tʃ' | n  | ʃ | ʒ |
| tɕ | tɕ' | ɲ  | ɕ |   |
| k  | k'  | ŋ  | x |   |

Note: In addition, Pingyao has the zero initial.

## Finals

|    |     |     |     |
|----|-----|-----|-----|
| a  | ia  | ua  | ya  |
| ɛ  | iɛ  |     | yɛ  |
|    |     | uə  | yə  |
| æ  |     | uæ  |     |
| ɔ  | iɔ  |     |     |
| ɿ  | i   | u   | y   |
| ɿ  |     | ɿ   |     |
| ər |     |     |     |
| ei |     | uei |     |
| eu | iəu |     |     |
| ɑŋ | iɑŋ | uɑŋ |     |
| əŋ | iŋ  | uŋ  | yŋ  |
| ʌʔ | iʌʔ | uʌʔ | yʌʔ |

Tones      13      35      53      23      54

## 6. Songjiang (Jiangsu...(1960))

## Finals

|    |     |     |     |
|----|-----|-----|-----|
| i  | i   | u   | y   |
| e  |     | ue  |     |
| ɛ  | iɛ  | ue  |     |
| a  | ia  | ua  |     |
| ɸ  |     |     | yɸ  |
| ɣ  | iɣ  |     |     |
| o  |     |     |     |
| ɔ  | io  |     |     |
|    | iu  |     |     |
| ər |     |     |     |
| ã  | iã  |     |     |
| ǎ  |     | uǎ  |     |
| eŋ | iŋ  | ueŋ | yŋ  |
| oŋ | ioŋ |     |     |
|    | iI? |     | yI? |
| ɛ? | iɛ? | ue? |     |
| a? | ia? |     |     |
| ə? | iə? | ue? |     |
| ɔ? |     | uo? |     |
| o? | io? |     |     |

## Initials

|    |    |     |     |    |
|----|----|-----|-----|----|
| p  | t  | ts  | tɕ  | k  |
| p' | t' | ts' | tɕ' | k' |
| b  | d  |     | dʒ  | g  |
| m  | n  |     | ɲ   | ŋ  |
| f  |    | s   | ɕ   | h  |
| v  |    | z   |     | ʃ  |

Note: In addition, Songjiang has the zero initial.

## Tones

|      |    |    |    |   |
|------|----|----|----|---|
| yin  | 53 | 44 | 35 | 5 |
| yang | 31 | 22 | 13 | 3 |

## Tones and Initials

|                                                          | 53 | 31 | 44 | 22 | 35 | 13 | 5 | 3 |
|----------------------------------------------------------|----|----|----|----|----|----|---|---|
| p t<br>p' t'<br>f s<br>ts tɕ<br>ts' tɕ'<br>ɕ h<br>k k' 0 | +  | -  | +  | -  | +  | -  | + | - |
| m n<br>l ɲ ɳ                                             | +  | +  | +  | +  | -  | +  | - | + |
| b d<br>dʒ g ʃ<br>v z                                     | -  | +  | -  | +  | -  | +  | - | + |

Note: + indicates co-occurrence; - otherwise.

## 7. Weining Miao (F.-S. Wang (1957))

## Consonants - oral

|     |      |     |      |
|-----|------|-----|------|
| p   | p'   | b   | b'   |
| t   | t'   | d   | d'   |
| t̥  | t̥'  | d̥  | d̥'  |
| k   | k'   | g   | g'   |
| q   | q'   | ɠ   | ɠ'   |
| ts  | ts'  | dz  | dz'  |
| tɕ  | tɕ'  | dʒ  | dʒ'  |
| tɕ̥ | tɕ̥' | dʒ̥ | dʒ̥' |
| tl  | tl'  | dl  | dl'  |
| f   |      | v   | v'   |
| s   |      | z   | z'   |
| ɕ   |      | ʒ   | ʒ'   |
| ɕ̥  |      | ʒ̥  | ʒ̥'  |
| x   |      | ɣ   | ɣ'   |
| χ   |      |     |      |
| h   |      | ɦ   |      |
| l   |      | l   | l'   |
|     |      | w   |      |

## Consonants - nasal

|     |      |     |      |
|-----|------|-----|------|
| mp  | mp'  | mb  | mb'  |
| nt  | nt'  | nd  | nd'  |
| nɿ  | nɿ'  | ndɿ | ndɿ' |
| nk  | nk'  | ng  | ng'  |
| nq  | nq'  | nG  | nG'  |
| nts | nts' | ndz | ndz' |
| ntʂ | ntʂ' | ndʒ | ndʒ' |
| ntɕ | ntɕ' | ndʑ | ndʑ' |
| ntl | ntl' | ndl | ndl' |
| m   |      | m   | m'   |
| n   |      | n   | n'   |
|     |      | n   | n'   |
| ɲ   |      | ɲ   | ɲ'   |
| ŋ   |      | ŋ   | ŋ'   |

## Vowels

## Monophthongs

i a o u y w ɪ ɨ w ʏ

Diphthongs ie ae au aw œy

Glides i (u y)

Tones 55 33 11

53 31

35 13



## Tone Sandhi in Numeral-Classifier Phrases

|       | ᳵ  | ᳶ  | ᳷  | ᳸  | ᳹  | ᳺ  | ᳻  | ᳼  | ᳽  | xᳵ |
|-------|----|----|----|----|----|----|----|----|----|----|
| I ᳵ   | ᳵ  | ᳵ  | ᳵ  | ᳵ  | ᳵ  | ᳵ  | ᳵ  | ᳵ  | ᳵ  | ᳵ  |
| III ᳵ | ᳶ  | ᳵ  | ᳵ  | ᳶ  | ᳵ  | ᳵ  | ᳶ  | ᳵ  | ᳵ  | ᳶ  |
| IV ᳶ  | ᳺ  | ᳶ  | ᳶ  | ᳺ  | ᳶ  | ᳶ  | ᳺ  | ᳶ  | ᳶ  | ᳺ  |
| II ᳸  | ᳵ  | ᳸  | ᳸  | ᳵ  | ᳸  | ᳸  | ᳵ  | ᳸  | ᳸  | ᳵ  |
| V ᳶ   | ᳷  | ᳶ  | ᳸' | ᳸' | ᳷  | ᳷  | ᳷  | ᳷  | ᳷  | ᳸' |
| VI ᳻  | ᳸' | ᳷' | ᳸' | ᳸' | ᳷' | ᳷' | ᳸' | ᳷' | ᳷' | ᳸' |
| VII ᳵ | ᳵ  | ᳸  | ᳸  | ᳵ  | ᳸  | ᳸  | ᳵ  | ᳸  | ᳸  | ᳵ  |

Note: Classifiers in Classes I, III, IV have voiceless onset initials; those in Classes II, V, VI and VII have voiced onset initials. The horizontal axis is the tone of the numerals; the vertical axis is the tone of classifiers. The tone letter and numeric notation correspondence is as follows:

ᳵ = 55      ᳶ = 33      ᳺ = 11      ᳻ = 53  
᳷ = 31      ᳸ = 35      ᳹ = 13

The ' sign after a tone letter indicates aspiration which the syllable-initial consonant acquires as a result of tone sandhi. The two tones in the last two columns together trigger the sandhi process; x is any tone.

## 8. Wenzhou (of the city variety, Zhengzhang (1964b))

## Initials

|    |     |   |    |    |    |   |   |
|----|-----|---|----|----|----|---|---|
| p  | p'  |   | m̃ | x  | b  | m |   |
|    |     | f |    | ṽ |    |   | v |
| t  | t'  |   | ñ | l̃ | d  | n | l |
| ts | ts' | s |    | z̃ | dz |   | z |
| tɕ | tɕ' | ɕ | ɲ̃ | j̃ | dʒ | ɲ | j |
| k  | k'  |   | ŋ̃ |    | g  | ŋ |   |
|    |     | h |    | ʔ  |    |   | ɦ |

Note: ~ indicates voicelessness.

## Finals

a    ɛ    e    ɤ    ɐ    o  
u    y    i    ɿ  
iɛ    yɐ    yɔ    uɔ  
ai    au    eu    ei  
ɤy    ɿu  
aŋ    eŋ    oŋ

Tones    a. 44    b. 45    c. 42    d. 323  
          A. 31    B. 34    C. 22    D. 212

## Bisyllabic Tone Patterns

| Tone Melodies         | Source Tones                              |
|-----------------------|-------------------------------------------|
| A. 22-33              | (a,A)-(a)                                 |
| B. 42-33<br>B'. 21-33 | (b,B,c,C)-(a)<br>(d,D)-(a)                |
| C. 22-2               | (a,A,c,d,D)-(A)                           |
| D. 43-34<br>D'. 21-34 | (a,A,b,B,c,C)-(b,B)<br>(d,D)-(b,B)        |
| E. 213-43             | (a,A)-(c,C)                               |
| F. 42-21<br>F'. 21-42 | (b,B,c,C)-(c)<br>(b,B,C)-(A)<br>(d,D)-(c) |
| G. 42-22<br>G'. 21-22 | (b,B,c,C)-(C)<br>(d,D)-(C)                |
| H. 43-12<br>H'. 21-12 | (a,A,b,B,c,C)-(d,D)<br>(d,D)-(d,D)        |

Note: the tone 213 is a variant of 22.

## 9. Wuyi (G.-T. Fu (1984))

## Initials

| I  | II | I   | II    |
|----|----|-----|-------|
| p  | b  | p'  | pf̃   |
| t  | d  | t'  | t̃f̃  |
| ts | dz | ts' | ts̃f̃ |
| tɕ | dʒ | tɕ' | tɕ̃f̃ |
| k  | g  | k'  | k̃f̃  |
| ʔ  | ŋ  | h   | hf̃   |

Appendix

| I | II | I  | II |
|---|----|----|----|
| f | v  | ʔm | ʔm |
|   |    | ʔn | ʔn |
| s | z  | ʔl | ʔl |
| ʃ | ʒ  | ʔɒ | ʔɒ |
|   |    | ʔɔ | ʔɔ |

Finals

|      | i, ɿ       | u            | y   |
|------|------------|--------------|-----|
| ɣ, w | ie         |              | ye  |
| a    | ia         | ua<br>uo, wo | ya  |
| au   | ieu<br>iau | uei          |     |
| əɔ   | iɔ         | ueɔ          | yeɔ |
| ɑɔ   | iaɔ        | uaɔ          | yaɔ |
| oɔ   | ioɔ        |              |     |
| æʔ   | iæʔ        | uæʔ          | yæʔ |
| ɣʔ   | ieʔ        |              | yeʔ |
| aʔ   | iaʔ        | uaʔ          |     |
|      |            | uoʔ          | yaʔ |
| oʔ   | ioʔ        | uoʔ          |     |
| auʔ  | iauʔ       |              |     |

Tones      With Class I initials

            yin            24    55    53    5

            With Class II initials

            yang            213   13    31    212

## 11. Xiamen (R. Cheng (1968))

## Consonants

|           | Obstruents | Affricates | Spirants |
|-----------|------------|------------|----------|
| vl.unasp. | p t k      | c          | s        |
| vl.asp.   | ph th kh ʔ | ch         | h        |
| vd.       | b l g      | j          |          |

Note: /b l g/ surface as [b l g] initially  
before oral vowels; [n m ŋ] elsewhere

Vowels i e a o u ə

Tones 55 35 53 31 33

## 10. Zhenjiang (H.-N. Zhang (1985))

## Initials

|    |    |     |     |    |
|----|----|-----|-----|----|
| p  | t  | ts  | tʂ  | k  |
| ph | th | tsh | tʂh | kh |
| m  | n  |     |     |    |
|    | l  |     |     |    |
| f  |    | s   | ʂ   | h  |
| w  |    | ʒ   | j   |    |

Note: In addition, there is the so-called zero  
initial.

## Finals

|          | i, ɿ, ĭ | u    | y, ȳ |
|----------|---------|------|------|
| a        | ia      | ua   |      |
| ɛ        | iɛ      | ue   |      |
| ɐr, o, ɔ | io      |      |      |
| ei       |         | uei  |      |
| eu       | iəu     |      |      |
| ɛ̃n      | iɛ̃n    | uɛ̃n |      |
| ən       |         | uən  |      |
| ũn       |         |      |      |
| aŋ       | iaŋ     | uaŋ  |      |
| iŋ       |         |      | yŋ   |
| oŋ       | ioŋ     |      |      |
| aʔ       | iaʔ     | uaʔ  |      |
| ɐʔ       | iʔ      | ueʔ  | yʔ   |
| oʔ       | ioʔ     | uoʔ  |      |

Tones      42    31    35    55    5

## References

- Alipour-Haghighi, F. I.R. Titze, A.L. Perlman (1989)  
"Tetanic Contraction in Vocal Fold Muscle." *Journal of Speech and Hearing Research* 32.2, 226-231.
- Anderson, S.R. (1978) "Tone Features." In Fromkin (1978).
- Anderson, S.R. (1982) "Differences in Rule Type and their Structural Basis." In H. van der Hulst and N. Smith (eds) *The Structure of Phonological Representations (part II)*. Foris, Dordrecht.
- Archangeli, D. (1985) "Yokuts Harmony: Evidence for Coplanar Representation in Nonlinear Phonology." *Linguistic Inquiry* 16.3, 335-373.
- Archangeli, D. and D. Pulleyblank (1989) "Yoruba Vowel Harmony." *Linguistic Inquiry* 20.2, 173-218.
- Bai, W.-R. (1989) "Guangzhou hua zhong de shengluo xing bianyin" (The Changed Tone under Deletion in Guangzhou) *Fangyan* 1989.2, 114-120.
- Bao, Z.-M. (1990) "Fangjie Languages and Reduplication." *Linguistic Inquiry* 21.3.
- Bogers, K., H. van der Hulst and M. Mous (eds.) (1986). *The Phonological Representation of Suprasegmentals*. Dordrecht, Foris.
- Cao, J.-F. and I. Maddieson (1989) "An exploration of phonation types in Wu dialects of Chinese." *UCLA Working Papers in Phonetics* 72, 139-60.
- Chao, Y.-R. (1930/80) "A System of Tone-Letters." *La Maitre Phonétique* 45, 24-47. Reprinted in *Fangyan* 1980.2, 81-82.
- Chao, Y.-R. (1931) "Fangjie ye ba zhong (Eight Varieties of Languages Based on the Principle of Fangjie)," *Bulletin of the Institute of History and Philology, Academic Sinica* 2, 320-354.
- Chao, Y.-R. (1947) *Cantonese Primer*. The Harvard-Yenching Institute, Cambridge, Massachusetts.

## References

- Chao, Y.-R. (1956) "Formal and Semantic Discrepancies between Different Levels of Chinese Structure." *Bulletin of the Institute of History and Philology, Academia Sinica*, vol 28.1, 1-16.
- Chao, Y.-R. (1968) *A Grammar of Spoken Chinese*, University of California Press, Berkeley, California.
- Chan, M. K.-M. (1989) "Contour-Tone Spreading and Tone Sandhi in Danyang Chinese," ms., The Ohio State University, Columbus. Paper presented as the First Northeast Conference on Chinese Linguistics.
- Chen, M. (1984) "Abstract Symmetry in Chinese," *Linguistic Inquiry* 15, 167-170.
- Chen, M. (1986a) "The Paradox of Tianjin Tone Sandhi," *CLS* 22, 98-154.
- Chen, M. (1986b) "An Overview of Tone Sandhi Phenomena across Chinese Dialects," ms. UCSD.
- Chen, M. (1987a) "Introductory Remarks," *Journal of Chinese Linguistics* 15, 203-227.
- Chen, M. (1987b) "The Syntax of Xiamen Tone Sandhi," *Phonology Yearbook* 4, 109-149.
- Cheng, C.-C. (1973) *A Synchronic Phonology of Mandarin Chinese*. Mouton, The Hague.
- Cheng, R. (1968) "Tone Sandhi in Taiwanese," *Linguistics* 41.
- Chomsky, N. and M. Halle (1968) *Sound Patterns of English*. Harper and Row, New York.
- Clements, G.N. (1983) "The Hierarchical Representation of Tone Features." In *Dihoff* (1983), 145-176.
- Clements, G.N. (1985a) "The Geometry of Phonological Features," *Phonology Yearbook* 2, 225-252.
- Clements, G.N. (1985b) "The Problem of Transfer in Nonlinear Morphology," *Cornell Working Papers in Linguistics* 7.
- Clements, G.N. (1989) "On the Representation of Vowel Height." ms., Cornell University.



## References

- Clements, G. and J. Goldsmith (eds.) (1984) *Autosegmental Studies in Bantu Tone*. Foris, Dordrecht.
- Clements, G. and S.J. Keyser (1983) *CV Phonology*. MIT Press, Cambridge, Massachusetts.
- Collier, R. and C.E. Gelfer (1984) "Physiological Explanations of  $F_0$  Declination," *Proc. of the Tenth International Congress of Phonetic Sciences*, edited by M.P.R. van den Broecke and A. Cohen. Foris, Dordrecht.
- Dihoff, I.R. ed. (1983) *Current Approaches to African Linguistics* (vol. 1). Foris, Dordrecht.
- Duanmu, S. (1990) "Against Contour Tone," ms. Massachusetts Institute of Technology, Cambridge, Massachusetts.
- Fromkin, V.A. (1972) "Tone Features and Tone Rules." *Studies in African Linguistics* 3.1, 47-76.
- Fromkin, V.A. (1974) "On the Phonological Representation of Tone." *Studies on Tone from the UCLA Tone Project. UCLA Working Papers in Phonetics* 27.
- Fromkin, V.A. (1978) *Tone: a Linguistic Survey*. Academic Press, New York.
- Fu, G.-T. (1984) "Wuyi fangyan de lianxü biandiao" (Tone Sandhi in the Wuyi Dialect). *Fangyan* 1984.2, 109-127.
- Fujimura, O. (1977) "Control of the Larynx in Speech," *Phonetica* 34, 280-288.
- Fujimura, O. (1981) "Body-Cover Theory of the Vocal Fold and its Phonetic Implications." In Stevens and Hirano (1981).
- Gandour, J. (1974) "Consonant Types and Tone in Siamese." *Studies on Tone from the UCLA Tone Project. UCLA Working Papers in Phonetics* 27.
- Goldsmith, J. (1976a) *Autosegmental Phonology*, Doctoral dissertation, MIT, Cambridge, Massachusetts.

## References

- Goldsmith, J. (1976b) "An Overview of Autosegmental Phonology," *Linguistic Analysis* 2.1, 23-68
- Halle, M. (1983) "On Distinctive Features and Their Articulatory Implementation," *Natural Language and Linguistic Theory* 1, 91-105.
- Halle, M. (1986) "On Speech Sounds and Their Immanent Structure," ms. MIT, Cambridge, Massachusetts.
- Halle, M. (1989) "The Intrinsic Structure of Speech Sounds," ms. MIT, Cambridge, Massachusetts.
- Halle, M. (1990) "An Approach to Morphology," ms. MIT, Cambridge, Massachusetts.
- Halle, M. and K. Stevens (1971) "A Note on Laryngeal Features," *Quarterly Progress Report* 101, MIT.
- Halle, M. and J.-R. Vergnaud (1980) "Three Dimensional Phonology," *Journal of Linguistic Research* 1.1, 83-105.
- Halle, M. and J.-R. Vergnaud (1982) "On the Framework of Autosegmental Phonology," in van der Hulst and N. Smith (eds).
- Hammond, M. (1988) "On Deriving the Well-Formedness Condition," *Linguistic Inquiry* 19, 319-325.
- Harvey, N. and P. Howell (1980) "Isotonic Vocalis Contraction as a Means of Producing Rapid Decreases in  $F_0$ ." *Journal of Speech and Hearing Research* 23, 576-592.
- Haudricourt, A.G. (1954) "De l'origine des Tons en Vietnamien." *Journal Asiatique* 242, 69-82.
- He, W. (1984) "Luoyang fang yan ji lui" (Notes on the Luoyang Dialect) *Fangyan* 1984.4, 278-299.
- Hewitt, M. and A. Prince (1990) "OCP, Locality, and Linking: the N. Karanga Verb," ms. Brandeis University, Waltham, Massachusetts.
- Hirano, M. (1981) "The Function of the Intrinsic Laryngeal Muscles in Singing." In Stevens and Hirano (1981).

## References

- Hirano, M., S. Kurito and T. Nakashima (1981) "The Structure of the Vocal Folds." In Stevens and Hirano (1981).
- Hirose, H. (1976) "Electromyography of the Larynx and Other Speech Organs." In Sawashima and Cooper (1976).
- Hirose, H. and M. Sawashima (1981) "Functions of the Laryngeal Muscles in Speech." In Stevens and Hirano (1981).
- Hombert, J. (1976) "Consonant Types, Vowel Height and Tone in Yoruba" *Studies on Production and Perception of Tones: UCLA Working Papers in Phonetics* 33.
- Hombert, J., J. Ohala, W. Ewan (1979) "Phonetic Explanations for the Development of Tones" *Language* 55.1, 37-58.
- Hòu, J.-Y. (1980) "Pingyao fangyan de liandu biandiao (Tone Sandhi in the Pingyao Dialect)," *Fangyan* 1980.1, 1-14.
- Hou, J.-Y. (1983) "Changzhi fangyan jilu" (Notes on the Changzhi Dialect) *Fangyan* 1983.4, 260-274.
- Hou, J.-Y., et al (1986) "Shanxi fangyan de feng qu" (Distribution of Shanxi Dialects) *Fangyan* 1986.2, 81-92.
- Hung, T. (1987) "Tianjin Tone Sandhi: towards a Unified Approach." *Journal of Chinese Linguistics* 15, 274-305.
- Hyman, L. ed. (1973a) *Consonant Types and Tone. Southern California Occasional Papers in Linguistics No. 1. University of Southern California, Los Angeles.*
- Hyman, L. (1973b) "The Role of Consonant Types in Natural Tonal Assimilations." In Hyman (1973a).
- Hyman, L. (1975) *Phonology - Theory and Analysis. Holt, Rinehard and Winston, New York.*
- Hyman, L. (1986) "The Representation of Multiple Tone Heights." In Bogers et al (1986), 109-152.

## References

- Hyman, L. (1989) "Register Tones and Tonal Geometry," ms., University of California, Berkeley. To appear in *The Representation of Tonal Register*, edited by Keith Snider and Harry van der Hulst. Foris, Dordrecht.
- Hyman, L. and R.G. Schuh (1974) "Universals of Tone Rules: Evidence from West Africa." *Linguistic Inquiry* 5.1, 81-115.
- Inkelas, S. (1987) "Tone Feature Geometry," in *Proceedings of NELS 18*.
- Jiangsu he Shanghai fangyan diaocha zhidao zu (The Investigation Group of Dialects in the Province of Jiangsu and the City of Shanghai) (1960) *Jiangsu sheng he Shanghai shi fangyan gaikuang* (An Outline of the Dialects in the Province of Jiangsu and the City of Shanghai), Jiangsu People's Press, Nanjing.
- Kao, D.L. (1971) *Structure of the Syllable in Cantonese*. Mouton, The Hague.
- Ladefoged, P. (1975) *A Course in Phonetics*. Harcourt Brace Jovanovich, New York.
- Lehiste, I. (1970) *Suprasegmentals*. MIT Press, Cambridge, Massachusetts.
- Levin, J. (1985) *A Metrical Theory of Syllabicity*, Doctoral dissertation, MIT, Cambridge, Massachusetts.
- Li, P. J.-K. (1985) "A Secret Language in Taiwanese," *Journal of Chinese Linguistics* 13, 91-121.
- Li, R. (1979) "Wenling fangyan de liandu biandiao" (Tone Sandhi in the Wenling Dialect) *Fangyan* 1979.1, 1-29.
- Li, X.-J. and Liu, S.-X. (1985) "Tianjin fangyan de lian du bian diao" (Tone Sandhi in Tianjin Dialect) *Zhongguo Yuwen* 184, 76-80.
- Li, Y.-S. et al (1959) "Miao yu sheng mu he sheng diao zhong de ji ge wenti" (Some Issues in the Consonants and Tones in Miao) *Language Research* 4, 65-80.

## References

- Lin, H.-B. and B.H. Repp (1989) "Cues to the Perception of Taiwanese Tones." *Language and Speech* 32.1, 25-44.
- Lin, Y.-H. (1988) "Nasal Segments in Taiwanese Secret Language," ms., University of Texas, Austin.
- Lü, S.-X. (1980) "Danyang fangyan de shengdiao xitong" (The Tonal System of the Danyang Dialect). *Fangyan* 1980.2, 85-122.
- McCarthy, J. (1979) *Formal Problems in Semitic Phonology and Morphology*. PhD Dissertation, MIT, Cambridge, Massachusetts.
- McCarthy, J. (1981) "A Prosodic Theory of Nonconcatenative Morphology," *Linguistic Inquiry* 12, 373-418.
- McCarthy, J. (1989a) "Linear Order in Phonological Representation," *Linguistic Inquiry* 20, 71-99.
- McCarthy, J. (1989b) "Gutturals," ms. University of Massachusetts, Amherst, Massachusetts.
- MacNeilage, P.F. (1983) *The Production of Speech*. Springer-Verlag, New York.
- Maddieson, I. (1974) "A Note on Tone and Consonants." *Studies on Tone from the UCLA Tone Project*. UCLA Working Papers in Phonetics 27.
- Marantz, A. (1982) "Reduplication," *Linguistic Inquiry* 13, 483-545.
- Matisoff, J. A. (1973) "Tonogenesis in Southeast Asia," in Hyman (1973a).
- Mei, T.-L. (1970) "Tones and Prosody in Middle Chinese." *Harvard Journal of Asiatic Studies* 30, 86-110.
- Myers, S. P. (1987) *Tone and the Structure of Words in Shona*. Ph.D dissertation, University of Massachusetts, Amherst.
- Odden, D. (1986) "On the Role of the Obligatory Contour Principle in Phonological Theory," *Language* 62, 353-383.

## References

- Ohala, J.J. (1972) "How is Pitch Lowered?" *Journal of the American Society of Acoustics* 52, 124.
- Ohala, J.J. (1977) "Speculations on Pitch Regulation," *Phonetica* 34, 310-312.
- Ohala, J.J. (1978) "Production of Tone," in Fromkin (1978).
- Pike, K. (1948) *Tone Languages*. University of Michigan Press, Ann Arbor.
- Prince, A. (1987) "Planes and Copying," *Linguistic Inquiry* 18, 491-510.
- Pulleyblank, D. (1986) *Tone in Lexical Phonology*. D. Reidel, Dordrecht, Holland.
- Pulleyblank, D. (1988) "Vocalic Underspecification in Yoruba." *Linguistic Inquiry* 19.2, 233-270.
- Pulleyblank, E. (1978) "The Nature of the Middle Chinese Tones and their Development to Early Mandarin." *Journal of Chinese Linguistics* 6.2, 172-203.
- Pulleyblank, E. (1984) *Middle Chinese: a Study in Historical Phonology*. Vancouver, University of British Columbia Press.
- Ramsey, S.R. (1987) *The Languages of China*. Princeton University Press, Princeton.
- Rao, C.-R. (1987) "Fujian Changting (Kejia) fangyan de lianxü biandiao" (Tone Sandhi in the Dialect of Changting, Fujian (Kejia)). *Zhongguo Yuwen* 1987.3, 191-200.
- Sagey, E.C. (1986) *The Representation of Features and Relations in Non-linear Phonology*. PhD Dissertation, MIT, Cambridge, Massachusetts.
- Sagey, E.C. (1988) "On the Ill-Formedness of Crossing Association Lines," *Linguistic Inquiry* 19, 109-118.
- Sawashima, M. and F. S. Cooper (1977) *Dynamic Aspects of Speech Production*. University of Tokyo Press, Tokyo.

## References

- Sawashima, M., H. Hirose (1983) "Laryngeal Gestures in Speech Production." In MacNeilage (1983).
- Shih, C.-L. (1986) *The Prosodic Domain of Tone Sandhi in Chinese*. PhD Dissertation, University of California, San Diego.
- Steriade, D. (1982) *Greek Prosodies and the Nature of Syllabification*. PhD Dissertation, MIT, Cambridge, Massachusetts.
- Steriade, D. (1986) "Locality Conditions and Feature Geometry," *NELS* 17, 595-617.
- Steriade, D. (1988) "Reduplication and Syllable Structure," *Phonology* 5, 73-155.
- Stevens, K. (1977) "Physics of Laryngeal Behavior and Larynx Modes," *Phonetica* 34, 264-279.
- Stevens, K. (1981) "Vibration Modes in Relation to Model Parameters." In Stevens and Hirano (1981).
- Stevens, K. and M. Hirano, eds. (1981) *Vocal Fold Physiology*. University of Tokyo Press, Tokyo.
- Stevens, K. and J.S. Perkell (1976) "Speech Physiology and Phonetic Features." In Sawashima and Cooper (1976).
- Tan, F. (1987) "Tone Sandhi in the Tianjin Dialect." *Journal of Chinese Linguistics* 15, 228-246.
- Trigo, L. (1988) *The Phonological Derivation and Behavior of Nasal Glides*. Doctoral dissertation, MIT, Cambridge, Massachusetts.
- Trubetzkoy, N.S. (1969) *Principles of Phonology*. University of California Press, Berkeley. Translated by C.A.M. Baltaxe.
- Wang, F.-S. (1957) "Guizhou Weining Miao yu liangci" (The Classifiers in the Miao Language in Weining, Guizhou) *Yuyan Yanjiu* 2, 75-122
- Wang, W. S-Y. (1967) "Phonological Features of Tone," *International Journal of American Linguistics* 33.2, 93-105.

## References

- Williams, E. (1971/76) "Underlying Tone in Margi and Igbo," *Linguistic Inquiry* 7.3, 463-484.
- Woo, N. (1969) *Prosody and Phonology*. PhD Dissertation, MIT, Cambridge, Massachusetts.
- Wright, M. (1983) *A Metrical Approach to Tone Sandhi in Chinese Dialects*. PhD Dissertation, University of Massachusetts, Amherst.
- Xia, J.-Q. (1983) "Liuyang Nanxiang fangyan jilue" (A Brief Note on the Liuyang (Nanxiang) Dialect) *Fangyan* 1983.1, 47-58.
- Xu, L. and Y.-S. Zhao (1964) "Bai yu gaikuang" (An Outline of the Bai Language) *Zhongguo Yuwen* 1964.4.
- Yan, S. (1981) "Gao'an (Laowu Zhoujia) fangyan de yuyin xitong" (The Sound System of the Gao'an (Laowu Zhoujia) Dialect) *Fangyan* 1981.2, 104-121.
- Yip, M. (1980) *The Tonal Phonology of Chinese*. PhD Dissertation, MIT, Cambridge, Massachusetts, and Indiana University Linguistics Club.
- Yip, M. (1982) "Reduplication and C-V Skeleta in Chinese Secret Languages," *Linguistic Inquiry* 13, 637-661.
- Yip, M. (1989) "Contour Tones". *Phonology* 6, 149-174.
- Yuan, J.-H. et al (1960) *Hanyu fangyan gaiyao* (An Introduction to Chinese Dialects). Language Reform Press, Beijing.
- Yue, S.-Y. (1979) "Guiyang Huaxi qu Jiading Miao hua de qianjia cheng fen." (Prefixes in the Miao Dialect of Jiading, Huaxi District, Guiyang City) *Minzhu Yuwen* 1979.3, 199-205.
- Yue-Hashimoto, O.-K. (1972) *Phonology of Cantonese*. Cambridge University Press, London.
- Zhang, C.-C. (1980) "Xining fangyan jilue" (Notes on the Xining Dialect) *Fangyan* 1980.4, 282-302.
- Zhang, H.-N. (1985) "Zhenjiang fangyan de liandu biandiao" (Tone Sandhi in the Zhenjiang Dialect) *Fangyan* 1985.3, 191-204.



## References

- Zhang, Z.-S. (1987) "The Paradox of Tianjin: Another Look." *Journal of Chinese Linguistics* 15, 247-273
- Zhengzhang, S.-F. (1964a) "Wenzhou yinxi" (The Sound System of Wenzhou) *Zhongguo Yuwen* 1964.1.
- Zhengzhang, S.-F. (1964b) "Wenzhou fangyan de liandu biandiao" (Tone Sandhi in the Wenzhou Dialect) *Zhongguo Yuwen* 1964.2.
- Zhengzhang, S.-F. (1980) "Wenzhou fangyan er-wei ci de yuyin bianhua" (Sound Change of the er Suffix in the Wenzhou Dialect) *Fangyan* 1980.4, 245-262.
- Zong, F.-B. (1964) "Guanyu Guangzhou hua Yin Ping diao de fenghua wenti" (On the Split of the Yin Ping Tone in Cantonese) *Zhongguo Yuwen* 1964.5, 376-389.