

ACCENT AND SYLLABLE STRUCTURE  
IN PASSAMAQUODDY

by

Philip Stanley LeSourd

S.B., Humanities  
Massachusetts Institute of Technology  
Cambridge, Massachusetts  
1974

Submitted to the Department of Linguistics  
and Philosophy  
in partial fulfillment of  
the requirements for the degree of  
Doctor of Philosophy

at the

Massachusetts Institute of Technology

September 1988

© Philip S. LeSourd 1988

The author hereby grants to MIT permission to reproduce and to  
distribute copies of this thesis document in whole or in part.

Signature of the author: \_\_\_\_\_  
Department of Linguistics  
September 14, 1988

Certified by: \_\_\_\_\_  
Kenneth Hale  
Thesis Supervisor

Accepted by: \_\_\_\_\_  
Wayne O'Neil  
Chairman, Departmental Committee

SEP 30 1988

Vol 1

LIBRARIES

## ABSTRACT

The focus of this study is a set of related problems in the phonology of Passamaquoddy involving stress assignment and syncope. Both of these processes make a distinction between "stressable" and "unstressable" vowels. In essence the stressable vowels are those which are available to the stress rules, while the unstressable vowels may be targets of syncope. Stress is assigned by a right-to-left alternating stress rule and a rule assigning stress to initial syllables; but the surface stress patterns of the language are more complex than one would expect on the basis of these principles alone, since only stressable vowels participate in stress assignment. Matters are further complicated by the fact that particular underlying vowels which are treated as unstressable in some positions come to be treated as stressable when they occur in other contexts.

Whether a basically unstressable vowel is counted or skipped over in assigning stress is determined by a disparate set of conditions. A striking part of this system is a principle which makes an unstressable vowel stressable if it occupies an even-numbered position in a series of such vowels, counting from left to right. Thus stress assignment in Passamaquoddy appears to be determined by syllable counts carried out both from right to left and from left to right. Unstressable vowels which do not become stressable in the course of derivations are subject to syncope in a diverse set of environments, reflecting the application of five distinct rules.

Three theories of the stressable/unstressable distinction are considered in this work. The first theory uses a diacritic feature [strong] to distinguish between stressable and unstressable vowels. The second approach posits an additional level of metrical structure, in addition to the foot and word levels generally assumed in metrical accounts of stress assignment, in order to represent stressable vowels as metrically more prominent than unstressable vowels. The third account exploits the descriptive power of theories of phonology which recognize a distinction between a segmental tier and a CV or timing tier. The central hypothesis of this CV theory of stressability is that unstressable vowels are floating segments at the point in derivations at which the rules of stress assignment and syncope are applicable. Adopting this hypothesis allows us to explain some of the conditions which determine stressability by relating them to the principles of syllabification in Passamaquoddy. The CV account also finds empirical support in the facts of stress and syncope in words which contain underlying vowel sequences.

Other aspects of the phonology of Passamaquoddy which are treated in some detail include the phonetic distribution of long and short vowels, a devoicing process which affects initial non-syllabic sonorants, a morphologically governed system of vowel mutations known as Initial Change, and a rule deleting final vowels which triggers adjustments in stress and intonation.

for Ray Sullivan

## ACKNOWLEDGEMENTS

David Perlmutter is an extraordinary teacher. If there is anything of merit in the work presented here, it is because of what I learned from him. His introductory syntax class at MIT in the fall of 1971 opened a new world for me. For the first time, I understood that the purpose of science is explanation. Within a month, I was hooked on linguistics.

My debt to Ken Hale is equally great. His humanism and his broad and deep understanding of language have been an inspiration to generations of us at M.I.T. It was his enthusiasm for non-Indo-European languages which convinced me to try my hand at field work.

My first introduction to Algonquian came in a class on Mesquakie that Ives Goddard taught at Harvard in 1975. The value of his research for my own studies will be clear from the references to his papers which appear throughout this work. In the spring of 1975, Karl Teeter offered me a chance to go with him to a Maliseet-Passamaquoddy orthography conference in Fredericton, N.B. It was there that I first had the opportunity to hear for myself what Maliseet and Passamaquoddy sound like.

Laura Knecht generously shared with me the results of her field work in Maine in the summer of 1975 and helped me to begin my study of Passamaquoddy that fall. My own work has greatly benefitted from Robert Leavitt's extensive knowledge of the language. Many of the examples that I cite reflect his observations rather than my own.

To Ives Goddard, Jorge Hankamer, David Perlmutter, and Karl Teeter I am grateful for comments on my early work on Mesquakie and Passamaquoddy morpho-syntax. Many of their observations have contributed to my understanding of Passamaquoddy grammar.

I have profited greatly from discussions of the material presented here with Harry Bochner, Nancy Chinchor, Leland George, Wilson Gray, Morris Halle, Robert Ingria, Paul Kiparsky, Jaklin Kornfilt, Karin Michelson, and Tim Stowell. Harry Bochner, Nick Clements, Leland George, Morris Halle, and Karin Michelson have all read drafts of various portions of this work and provided valuable insights, suggestions, and criticisms. I owe special thanks to the members of my committee, Ken Hale, James Harris, Jay Keyser, and Karl Teeter, for their patience with lengthy drafts appearing at lengthy intervals. Dan Leary has provided crucial assistance with the M.I.T. word-processing equipment.

My mother, Margaret S. LeSourd, and my father and step-mother, David A. LeSourd and Margaret A. LeSourd, provided a haven from the world of work and responsibility during crucial periods of the writing of this document.

Above all, I am indebted to the native speakers of Passamaquoddy and Maliseet who have worked with me over the years. First Wayne Newell and then Anna and Albert Harnois not only worked hard to teach me their language, but provided a home for me as well. Philomene Dana, David Francis, Simon Gabriel, Joseph Nicholas, and Peter Paul also put in long hours with me. Some of the many others who have made valuable contributions are listed in Chapter 1.

## TABLE OF CONTENTS

Abstract.....	1
Acknowledgements.....	iii
Chapter 1 Introduction.....	1
1.1 Analytical problems and proposals.....	3
1.2 Sources.....	7
1.3 Plan of the work.....	9
1.4 A note on the writing system.....	12
Notes to Chapter 1.....	13
Chapter 2 Overview of Morphology.....	14
2.1 Grammatical gender.....	16
2.2 Gender selection.....	18
2.3 The structure of stems.....	24
2.4 The inflection of nouns.....	30
2.5 The inflection of verbs.....	39
2.5.1 Passamaquoddy verb modes.....	40
2.5.2 General characteristics of inflection in the various modes.....	49
2.5.3 Aspects of TA and TA+O inflection.....	53
Notes to Chapter 2.....	64
Chapter 3 Phonetics and Orthography.....	66
3.1 Phonemes and allophones.....	68
3.2 Plain, preaspirated and long consonants.....	76
3.3 Vowel length.....	81
3.3.1 Vowel length in Maliseet.....	82
3.3.2 Vowel length in Passamaquoddy.....	90
3.3.3 Vowel length and assimilation.....	93

3.4	Distributional restrictions.....	111
3.5	Accent.....	119
	Notes to Chapter 3.....	130
Chapter 4	Stress Assignment.....	133
4.1	Stress assignment and stress subordination.....	140
4.2	When /ə/ counts for stress placement.....	149
4.2.1	Basic conditions for stressability.....	150
4.2.2	H-Deletion I and I-Backing.....	158
4.2.3	Word-initial /(C)ə [+sonorant]ə /.....	162
4.2.4	Alternating stressability.....	166
4.2.5	Inherently stressable /ə/.....	177
4.3	Stressability as a diacritic feature.....	182
4.4	A metrical theory of stressability.....	190
4.4.1	Three layers of metrical structure.....	191
4.4.2	The representation of stressable and unstressable vowels.....	195
4.4.3	Subfoot formation and foot formation.....	196
4.4.4	Alternating stressability.....	198
4.4.5	Inherently stressable /ə/.....	201
4.4.6	Accent assignment rules.....	203
4.4.7	Strengths and weaknesses of the metrical analysis.....	209
4.5	A CV theory of stressability.....	214
4.5.1	Unstressable /ə/.....	218
4.5.2	V-Epenthesis.....	223
4.5.3	Syllabification.....	226
4.5.4	V-Epenthesis and syllabification.....	230

4.5.5	Final Syllable Epenthesis.....	244
4.5.6	Alternating stressability.....	247
4.5.7	Extrametricality.....	253
4.5.8	S-HS Epenthesis.....	260
4.5.9	Schwa in word-initial /((C)ə [+sonorant]ə)/.	261
4.5.10	Inherently stressable /ə/.....	265
4.5.11	Strengths and weaknesses of the CV theory.	267
4.6	I-Mutation.....	272
4.7	Stress Shift.....	278
	Notes to Chapter 4.....	282
Chapter 5	Syncope of /ə/.....	285
5.1	Arguments for deletion.....	290
5.2	Deletion of /ə/ before obstruents.....	302
5.2.1	Schwa in final syllables.....	309
5.2.2	Cluster effects.....	312
5.2.3	Alternating stressability.....	317
5.2.4	Word-initial /((C)ə [+sonorant]ə)/.....	322
5.2.5	Schwa between /s/ and /hs/.....	323
5.2.6	Inherently stressable /ə/.....	325
5.2.7	Exceptions to pre-obstruent syncope.....	327
5.2.8	Schwa Deletion I.....	334
5.2.9	Schwa Deletion and V-slot epenthesis.....	338
5.2.10	Extrametricality.....	349
5.2.11	The syllabification of /s/.....	352
5.2.12	Syncope after geminates? .....	365
5.2.13	The diacritic alternative.....	370
5.2.14	The metrical alternative.....	375

5.3	Devoicing of initial sonorants.....	377
5.3.1	Devoicing of /m/.....	379
5.3.2	Devoicing of /n/.....	386
5.3.3	Phonetics of the first person prefix.....	396
5.3.4	Devoicing of /w/.....	399
5.3.5	Phonetics of the third person prefix.....	410
5.3.6	The role of syllabification.....	419
5.3.7	Looking back and looking ahead.....	434
5.4	Underlying and derived clusters.....	439
5.4.1	Arguments for underlying clusters.....	440
5.4.2	The underlying forms of the prefixes.....	445
5.5	Deletion of /ə/ before /hV/.....	458
5.5.1	Schwa Deletion II.....	460
5.5.2	VHV Assimilation.....	466
5.5.3	Syncope before /hV/ is schwa-deletion.....	471
5.6	Deletion of /ə/ between /h/ and /m/.....	475
5.6.1	Schwa Deletion III.....	475
5.6.2	H-Deletion II.....	490
5.7	Schwa deletion and geminate formation.....	494
5.7.1	Deletion of /ə/ between sonorants.....	496
5.7.2	Deletion of /ə/ between obstruents.....	505
5.7.3	Deletion in the environment of complex segments.....	509
5.7.4	An additional rule of V-slot epenthesis....	518
5.7.5	Geminate formation.....	523
5.7.6	Leftward Spreading.....	537
5.7.7	Generalizing Geminate Deletion.....	540



5.8	Two rules deleting /h/.....	546
5.8.1	H-Deletion III.....	546
5.8.2	H-Deletion IV.....	554
5.9	Deletion of word-initial /ə/.....	562
5.9.1	Deletion before obstruents.....	565
5.9.2	Deletion before sonorants.....	570
5.9.3	Deletion and stressability.....	575
	Notes to Chapter 5.....	581
Chapter 6	Syncope of /i/, /a/, and /o/.....	584
6.1	Syncopating /i/.....	588
6.2	Syncopating /a/.....	603
6.3	Syncopating /o/.....	620
6.4	Extending the CV theory of syncope.....	623
6.4.1	H-Deletion V.....	626
6.4.2	Generalizing the syncope rules.....	627
6.4.3	V-Epenthesis.....	632
6.4.4	Idiosyncrasies in underlying syllabification? .....	637
6.4.5	Initial Syllable Epenthesis.....	640
6.4.6	Final Syllable Epenthesis.....	643
6.4.7	S-HS Epenthesis.....	644
6.5	An abstract alternative.....	645
6.6	Syncope and palatalization.....	654
6.6.1	Connective /i/.....	655
6.6.2	Palatalization.....	662
	Notes to Chapter 6.....	674

Chapter 7	Epenthesis on the Segmental Tier.....	676
7.1	Epenthetic /ə/.....	678
7.2	Schwa Epenthesis and O-Epenthesis.....	687
7.3	Conclusion.....	695
	Notes to Chapter 7.....	701
Chapter 8	The Treatment of Underlying Vowel Sequences.....	704
8.1	Glide Insertion.....	707
8.1.1	Glide insertion within stems.....	708
8.1.2	Glide insertion in inflection: Conjunct forms.....	711
8.1.3	Further inflectional cases.....	713
8.2	Vowel Elision.....	718
8.3	E-Mutation.....	725
8.3.1	The output of E-Mutation is a floating vowel.....	728
8.3.2	The output of E-Mutation is /i/.....	735
8.4	Questions of rule order.....	739
8.4.1	Vowel Elision and VHV Assimilation.....	740
8.4.2	VHV Assimilation and Schwa Deletion III...	743
8.4.3	Glide Insertion and Vowel Elision.....	746
8.4.4	Consequences for the formulation of Glide Insertion.....	747
8.4.5	Consequences for stress and syncope.....	749
	Notes to Chapter 8.....	758

Chapter 9	Initial Change.....	760
9.1	Effects on /ə/.....	763
9.2	The role of stressability.....	771
9.3	Change in <u>iy</u> and <u>ow</u> .....	777
9.4	Irregular Changed forms.....	785
9.5	Conclusion.....	788
	Notes to Chapter 9.....	791
Chapter 10	Final Vowel Deletion.....	792
10.1	Two conceptions of Passamaquoddy prosodics.....	794
10.2	Final Vowel Deletion.....	797
10.3	Word-final abstract vowels.....	816
	Notes to Chapter 10.....	827
Bibliography.....		829

## Chapter 1

### Introduction

Maliseet-Passamaquoddy is an Eastern Algonquian language of Maine and New Brunswick. Maliseet (or Malecite) is spoken in the area around Houlton, ME, and on six reserves along the St. John River in New Brunswick. Passamaquoddy is spoken in two communities in Maine, one at Pleasant Point, on the coast near Eastport, the other in Indian Township, some thirty miles inland at the headwaters of the St. Croix River. The two dialects are mutually intelligible, although there are many minor differences between them. The present work is primarily concerned with the phonological structure of Passamaquoddy, although some Maliseet material, primarily from Woodstock, N.B., is also brought into the discussion.

The focus of this study is a set of related problems involving stress assignment and syncope. Both of these processes make a distinction between what I call "stressable" and "unstressable" vowels. In essence the stressable vowels are those which are available to the stress rules (although they are not necessarily stressed), while the unstressable vowels may be targets of syncope (provided that certain segmental conditions are met). The same distinction will also be shown to play a role in a variety of other areas of the phonology of Passamaquoddy, including the use of epenthetic vowels, the treatment of

underlying vowel sequences, and certain aspects of the morphologically conditioned vowel mutations known as Initial Change. An account of the nature of the stressable/unstressable distinction and of the system of rules which determine the distribution of stressable and unstressable vowels is the principal analytical contribution of this work.

A second objective of this study has simply been to present a substantial body of data on the phonology of Passamaquoddy in an analytical framework which reveals the major generalizations in this domain, so that other scholars will be able to draw on Passamaquoddy material in their investigations of matters of theoretical interest. For this reason, I have tried as much as possible to present the whole picture, or as much of it as I have been able to see, in areas where there is variation among speakers or within the speech of particular individuals. An account which concentrated on "basic patterns" or "regular cases" would undoubtedly be easier to read, but would run the risk of giving an inaccurate view of the nature of the phonological processes of the language.

Many areas of the grammar of Passamaquoddy are undergoing rapid change, with the result that there are important differences among speakers of different age groups. Some of this variation undoubtedly reflects the decline in the use of the language among the youngest members of the community, but certain types of variation are common even in the speech of my oldest consultants, for whom English was very much a second language. Of course there are also differences between the Passamaquoddy of Pleasant Point and the Passamaquoddy of Indian Township, but I

suspect that differences among extended family groups in fact play a larger role than geography in dialect variation.

### 1.1 Analytical problems and proposals

It is easy to show that the basic principles of stress assignment in Passamaquoddy are a right-to-left alternating stress rule and a rule assigning stress to word-initial syllables. The surface stress patterns of many words are much more complicated, however, than we would expect on the basis of these principles alone, since only stressable vowels participate in the process of stress assignment. Matters are further complicated by the fact that particular underlying vowels which are treated as unstressable in some positions come to be treated as stressable when they appear in other contexts.

Whether or not a basically unstressable vowel should be counted or skipped over in assigning stress is determined by a disparate set of conditions. A striking part of this system is a principle which makes a basically unstressable vowel stressable if it occupies an even-numbered position in a series of such vowels, counting from left to right. Thus stress assignment in Passamaquoddy appears to be determined by syllable counts carried out both from right to left and from left to right.

Basically unstressable vowels which do not become stressable in the course of derivations are subject to syncope in a diverse class of environments. Five distinct, but formally similar rules of deletion appear to be involved. Most of the unstressable vowels which are retained in surface forms are schwas, but I will

argue that underlyingly unstressable occurrences of /i/, /a/, and /o/, as well as /ə/, are subject to two of the rules of syncope.

Three theories of the stressable/unstressable distinction will be considered in this work. The first of these accounts uses a diacritic feature [strong] to distinguish between stressable and unstressable vowels. The second approach posits an additional level of metrical structure, in addition to the foot level and word level generally assumed in metrical accounts of stress assignment, in order to represent stressable vowels as metrically more prominent than unstressable vowels. The third proposal exploits the descriptive power of theories of phonology which recognize a distinction between a segmental tier and a CV or timing tier in phonological representations. The central hypothesis in this account is that unstressable vowels are floating segments -- elements of the segmental tier which are not associated with positions on the timing tier -- at the point in derivations at which the rules of stress assignment and syncope are applicable.

The diacritic theory of stressability is intended as a formalization and extension of the approach which a number of Algonquianists have taken in working on similar problems. Both the account of stress and syncope in Delaware in Goddard (1969) and the analysis of syncope in Maliseet in Sherwood (1983b) make crucial use of a distinction between "weak" and "strong" vowels which is partly lexically determined and partly determined by rule.

Although a descriptively accurate account of the Passamaquoddy data can be presented in a framework of this kind,

the use of a diacritic feature to distinguish between stressable and unstressable vowels implies that the distinction has no phonological basis. This seems highly unlikely, since rule after rule in the phonology of Passamaquoddy refers to the stressable/unstressable distinction.

The metrical theory of stressability is based on a proposal that Nancy Chinchor and I first put forward in 1978, which has since been developed in work by Stowell (1979) and Halle and Vergnaud (1984). Both the original work to which I contributed and the subsequent elaborations of this approach have dealt only with a relatively small range of facts concerning the distribution of stressable and unstressable vowels, essentially limited to the role of a left-to-right syllable count in determining this distinction.

If this were, indeed, the only principle at work in determining when underlyingly unstressable vowels should be counted in stress assignment, then we would undoubtedly want to adopt a metrical account of stressability. This type of syllable counting is, after all, precisely the sort of phenomenon for which metrical theory is best suited. Moreover, there can be little doubt that the stressable/unstressable distinction reflects a distinction between stressed and unstressed vowels at some stage in the history of the language.<sup>1</sup> But a variety of other conditions are also involved in the phonological assignment of stressable status, notably a condition which requires underlyingly unstressable vowels to be treated as stressable after certain consonant clusters. These additional constraints can be incorporated into a metrical account of stressability, but



only at the cost of a heavy reliance on accent assignment rules which stipulate, but do not explain, the facts.

I will argue that a more explanatory account of stress and syncope in Passamaquoddy is available if we make use of the power of a theory like the CV phonology of Clements and Keyser (1983) which allows us to distinguish between segments and timing slots. Once we recognize unstressable vowels as underlying floating segments, several of the constraints on the distribution of stressable and unstressable vowels, including the principle of alternating strong and weak positions, can be directly related to the principles of syllabification which govern the class of possible consonant clusters in Passamaquoddy. This approach is modeled on the account which Michelson (1986) has offered for a formally similar problem in the analysis of stress assignment in Mohawk.

For the most part, the arguments that I will present are based on the relative explanatory power of the metrical and CV accounts of stressability. I know of only one area in the phonology of Passamaquoddy where these two approaches lead to clearly different empirical results. Without ad hoc additional stipulations, a metrical theory leads to incorrect predictions about stress assignment and syncope in certain forms which contain underlying vowel sequences. The same facts follow without additional stipulations from the basic assumptions of the CV approach.

## 1.2 Sources

The principal source of the Passamaquoddy data discussed in this work is my own field notes, collected at Indian Township and at Pleasant Point during several periods of work in Maine: six weeks in June and July, 1976; a week in January, 1977; about fourteen months from the end of May, 1977 to early August, 1978; another four weeks in July, 1979; and several short trips since. I have also made extensive use of the material collected by Laura Knecht at Indian Township during June and July, 1975.

The Passamaquoddy speakers with whom I have worked most closely at Indian Township are Anna Harnois, Philomene Dana, and Simon Gabriel, while my principal consultant at Pleasant Point has been David Francis, Sr. I will occasionally give the initials of one of these speakers when citing forms in the context of discussions of individual variation.<sup>2</sup>

Other speakers who have helped me in my study of the Passamaquoddy language include Albert Dana, Charles Dana, Coleen Dana, Vickey Dana, Lorraine Gabriel, Peter Gabriel, Albert Harnois, Audrey Harnois, Estelle Neptune, Joseph Nicholas, Wayne Newell, George Sockabasin, Mary Ellen Socobasin, Aloysius Sopiél, and Beverly Sopiél.

Most of the Maliseet data which is cited in this study was provided by Peter Lewis Paul of Woodstock, N.B. Other Maliseet speakers who have contributed to my understanding of their language include Veronica Atwin of Kingsclear, N.B., and Maxine Tomah, originally from Tobique, N.B., but for several years a resident of Indian Township, ME.

Early sources which have been especially useful in my study of Passamaquoddy include Joseph Barratt's Key to the Indian Language of New England... (1850), Abby Langdon Alger's "A Collection of Words and Phrases taken from the Passamaquoddy Tongue" (1885), and several of the works of John Dyneley Prince, notably "The Passamaquoddy Wampum Records" (1897), "A Passamaquoddy Tobacco Famine" (1917), and Passamaquoddy Texts (1921).<sup>3</sup> Other sources are mentioned in the text where they are relevant and are listed in the bibliography.

The modern period of linguistic work on Maliseet and Passamaquoddy begins with Karl Teeter's "Preliminary Report on Malecite-Passamaquoddy" (1967) and "The Main Features of Malecite-Passamaquoddy Grammar" (1971). Ives Goddard's "Preliminary Informal Statement of Malecite Prosodics" (1970) suggested an accentual notation for Maliseet-Passamaquoddy from which the system of accent marking that I have used is adapted. Two unpublished papers by Janet Warne, "A Historical Phonology of Malecite" (1977a) and "The Genetic Relationship of Abenaki, Penobscot, and Malecite" (1977b) have provided valuable information of the history of the language. Important contributions to our understanding of the phonetics of vowel length have been made by László Szabó, notably in his Indianisches Wörterbuch (1981). A reasonably complete picture of verbal inflection is now available from the Passamaquoddy-Maliseet Verb Paradigms of Robert M. Leavitt and David Francis, Sr., (1983, 1984) and David Sherwood's Maliseet-Passamaquoddy Verb Morphology (1983b, 1986). The teaching manual Nihtawewest/I Know How to Speak (Leavitt et. al. 1986) contains a great deal of

useful information on noun and verb inflection and many other aspects of the grammar of Maliseet-Passamaquoddy. Leavitt and Francis (1984) is an edited version of my Preliminary Passamaquoddy Dictionary of 1979.

The Wabnaki Bilingual Education Program at Indian Township and its successor, The Passamaquoddy-Maliseet Bilingual Education Program, which now serves the Houlton Band of Maliseet Indians as well as the Passamaquoddy communities of Pleasant Point and Indian Township, have published a large number of texts over the last fifteen years, including re-edited versions of many of the traditional narratives in Prince's Passamaquoddy Texts. (A partial listing of this material is given in Teeter (1978).) I have made extensive use of these publications in my informant work.

### 1.3 Plan of the work

From a morphological point of view, Passamaquoddy is in most respects a typical Algonquian language. Readers who are acquainted with Bloomfield's classic grammars of Menomini (1962) and Eastern Ojibwa (1958) or with Goddard's study of Delaware verbal morphology (1979b) will find themselves on familiar ground. For readers who are less familiar with Algonquian languages, a brief sketch of Passamaquoddy morphology is given in Chapter 2.

Chapter 3 provides a description of the phonetics of Passamaquoddy, with some remarks on Maliseet. Much of the chapter is devoted to an analysis of the distribution of short and long vowels in the two dialects. Vowel length is conditioned

in part by stress, but length and stress do not always occur in the same locations. An understanding of the relationship between these two types of prominence is therefore a prerequisite for any analysis of accentuation.

Chapters 4, 5, and 6 are the core of this work. Chapter 4 provides a descriptive account of the distribution of stressable and unstressable vowels and compares three formal treatments of this distribution in the frameworks sketched briefly above. The rules of stress assignment and stress subordination which apply to the output of the rules determining stressability are also formulated in this chapter. Chapter 5 motivates and formalizes the five rules of syncope which affect underlying /ə/, along with a variety of other phonological processes in the language which modify the output of the syncope rules in various ways. Chapter 6 extends the analysis of Chapter 5 to alternations which involve occurrences of i, a, and o which cannot be derived from /ə/ in a synchronic analysis of Passamaquoddy.

A full account of the phonology of the Passamaquoddy inflectional system would require a discussion of the idiosyncratic properties of a large number of morphemes and is clearly beyond the scope of this work. Chapter 7 presents an analysis of two of the more regular processes in this domain, both of which insert epenthetic vowels before certain suffixes. The rule for the use of epenthetic /ə/ is of particular interest with respect to the central theme of this work, since it introduces unstressable vowels. Given the CV theory of stressability which is proposed and defended in Chapters 4-6,

this rule can be seen as a process which inserts material only on the segmental tier, thus creating floating vowels.

Chapter 8 provides an analysis of several rules which interact in words whose underlying forms contain vowel sequences. I argue here that diacritic and metrical theories of the stressable/unstressable distinction lead to incorrect predictions about patterns of stress and syncope in one class of forms of this type, but that the observed patterns are to be expected if we adopt the CV approach suggested in Chapter 4.

The morphologically conditioned vowel mutations known as Initial Change are an important source of information about underlying forms, since mutation affects underlying vowels which may be deleted in syncope. Chapter 9 presents an analysis of these mutations and demonstrates in particular that one part of this system distinguishes between underlying stressable and unstressable vowels.

Not only stress, but certain aspects of word intonation are distinctive in Passamaquoddy. For the most part, the intonational contrasts of the language appear to have been the historical result a process by which final vowels were lost in many words. Many of the intonational contrasts found in the contemporary language correlate with the application of a synchronic rule of Final Vowel Deletion. This rule and its accentual effects are briefly discussed in Chapter 10. Because there is much that remains mysterious in this area of Passamaquoddy phonology, the analysis presented in this chapter is necessarily quite tentative.

#### 1.4 A note on the writing system

Readers who are familiar with standard Passamaquoddy orthography may wonder how the writing system used here is related to that system. The relationship is in fact quite close: a few simple substitutions will convert any form given in this work into its usual Passamaquoddy spelling. These substitutions are explained in the following paragraphs.

An h before a consonant at the beginning of a word should be replaced by an apostrophe. The [h] sound may occasionally be heard in this position when the word is pronounced together with a preceding word which ends with a vowel, but h in such cases more often represents an effect on the following sound than a sound in its own right.

The letter o should be replaced everywhere by u. The symbol a (schwa) should be replaced by o everywhere except where it is followed by w, where it should also be replaced by u.

The combination kw should be replaced by q, except at the beginning of a word where k is the second person prefix. Here there is a difference between a simple "kw" sound and a sequence of k and w.

The letter k should simply be dropped at the beginning of a word where it is followed by k or kw. The extra k in these forms is written only as a mark of the slightly tenser (more clearly voiceless) pronunciation of initial k or q in paradigmatic forms which take the second person prefix k before other consonants.

-- Notes --

1. Given the widespread occurrence in Algonquian languages of phonological phenomena which reflect a left-to-right syllable count, this stage might even have been Proto-Algonquian. The vowel length alternations of Menomini (Goddard, Hockett, and Teeter 1972; Miner 1981) offer a particularly interesting parallel.

2. Simon Gabriel, born in 1903, is the oldest speaker with whom I have worked. His early years were spent at St. Mary's, outside Fredericton, N.B., and certain characteristics of his speech probably reflect this Maliseet background.

3. Prince's major analytical work, "The Morphology of the Passamaquoddy Language of Maine" (1914) contains much that is of interest but includes many forms which resemble nothing that I have encountered in the language.



## Chapter 2

### Overview of Morphology

The parts of speech in Passamaquoddy are noun, verb, and particle. Both nouns and verbs are highly inflected, largely by suffixation. Verb forms with as many as seven inflectional suffixes are not uncommon.<sup>1</sup> Particles are uninflected (although some have diminutive forms).

The discussion in this chapter is intended only to give the reader an acquaintance with the basic morphological categories of the language and some idea of the structure of stems. The terminology is that of Bloomfield (1946, 1958, 1962), with certain modifications and additions as suggested in Goddard (1969). For aspects of Algonquian morphology not covered in the following remarks, the reader should consult these sources or Sherwood's study of the Maliseet verb (1983b).

The segmentations and glosses of Passamaquoddy forms provided in this work should be considered provisional except where they are specifically discussed in the text. The glosses are meant only to be suggestive. Thus, for example, the reader should not assume that the stem /pask-ən-/ 'break with the hand' consists of a verbal element and an instrumental suffix simply because I have glossed /pask-/ as 'break' and /-ən-/ as 'by hand.' I am not aware of any evidence which would favor such an

analysis over one in which /pask-/ is taken to mean 'broken' and /-ən-/ to mean 'act on with the hand' -- or one in which "verbal meaning" is simply a property of the stem as a whole.

Not all forms are segmented as fully as possible. Moreover, there are many cases in which it is difficult to justify historically plausible morphological analyses on synchronic grounds. I have tried for the most part to be conservative in dividing words into morphemes, indicating morpheme boundaries only where I am aware of some synchronic justification for the analysis. Some plausible analyses are ignored, however, where further segmentation would simply obscure the phonological point under discussion.

As a rule, I gloss grammatical morphemes in capital letters and non-grammatical morphemes in small letters, but there are many cases in which this distinction is made arbitrarily. Derivational suffixes are often glossed only by the gender-selection class of the stems which they derive, as discussed below, even where some abstract meaning might be attributed to them on the basis of a careful analysis of lexical semantics. Glosses are given in parentheses for morphemes which are present in the underlying form of a word but which are not represented in the surface form by any segmental material. Periods are written between words in glosses when more than one word is used to gloss a single morpheme. A list of the abbreviations used in this work is given at the end of this chapter.

## 2.1 Grammatical gender

With certain exceptions, to be noted below, every Passamaquoddy noun is assigned to one of two grammatical genders, conventionally termed animate and inanimate. Gender is reflected both in the inflection of nouns and in verbal agreement. The (proximate) plural forms of animate nouns end in -ək ~ -k ~ -ik while the plural forms of inanimate nouns end in -əl ~ -l ~ -il.

In European languages with grammatical gender, it is not uncommon for synonyms or near synonyms to be assigned to different gender classes, e.g. German die Frau 'the woman' (feminine) but das Weib 'the woman' (neuter). This situation is almost never found in Passamaquoddy. In fact the gender of nouns is entirely predictable within certain semantically defined domains. One semantically based principle assigns all nouns which refer to living, self-moving beings of any kind to the animate gender (hence the name of this class): èl 'doe' (pl. éliyik), éss 'clam' (pl. éssək). Another makes all nouns animate which refer to objects which are conventionally used to hold liquids: émkwan 'spoon' (pl. émkwánək), póhtày 'bottle' (pl. póhtáyak; from French bouteille); compare inanimate mítsòt 'fork' (pl. mítsótiyil), páksis 'box,' (pl. páksísəl; from English box). Nouns which refer to playing cards are also animate: tələpsis 'club' (pl. tələpsís k; from French trèfle), psóhon 'heart' (pl. psóhónək); compare inanimate psóhon 'heart (organ)' (pl. psóhónəl). Other rules of this type undoubtedly exist (mostly assigning nouns to the animate gender). One might,

in fact, take each noun and its near synonyms to define a semantic field with an associated gender rule.<sup>2</sup>

Despite the regularity of gender assignment in some domains, gender is arbitrary in other parts of the vocabulary (apart from the restriction on the gender of synonyms). Thus láləkihíkən 'drill bit' is inanimate (pl. láləkihíkənəl), but kíttəkən 'file (for working wood or metal)' is animate (pl. kíttəkənək); sàht 'blueberry' is inanimate (pl. sàhtiyil), but pskíhkwímíns 'strawberry' is animate (pl. pskíhkwímínsək). In cases like these in which gender is arbitrary we find individual and dialect variation. Thus cíhkihíkən 'broom' is animate (pl. cíhkihíkənək) for most Passamaquoddy speakers, but inanimate (pl. cíhkihíkənəl) for some; təmétos 'tomato' is an inanimate noun in Indian Township (pl. təmétósəl), but an animate noun at Pleasant Point (pl. təmétósək). Occasionally a single speaker will use both animate and inanimate forms of the same noun. Thus one speaker (D.F) reports that nekəson 'sleeping mat' may be either animate or inanimate (pl. nekəsón k or nekəsónəl). It seems clear, then, that the animate/inanimate distinction is truly one of grammatical gender, despite the fact that gender has various semantic correlates.

The suffix /-eya-/ forms nouns which be either animate or inanimate, according to the referent: píléyak 'new things (an.),' píléyal 'new things (in.).' Nouns of this type are frequently used in apposition with other nouns, where they function much like adjectives.

## 2.2 Gender selection

Verbs in Passamaquoddy, as in other Algonquian languages, impose restrictions on the grammatical gender of one of their arguments. For intransitive verbs, the restricted argument is the subject. For transitive verbs, it is the (primary) object. A class of basically intransitive stems may be used with a nominal complement but nonetheless impose gender restrictions on their subjects.

Subjects of Animate Intransitive (AI) verbs must be grammatically animate. Subjects of Inanimate Intransitive (II) verbs must be grammatically inanimate. Thus the animate noun épéskámákən 'ball' (pl. épéskámákənək) may appear as the subject of /əpi-/ AI 'sit, be located,' as shown in (1a), but not as the subject of /əte-/ II 'be located.' On the other hand, the inanimate noun tówhpòt 'table' (pl. tówhpótiyil) may appear as the subject of /əte-/, as shown in (1b), but not as the subject of /əpi-/.

- (1) a. épéskámá-kən əpó pskíhkwi'-hko-k.  
play.ball-NOM sit-(3) blade.of.grass-PL-LOC  
'The ball is on the grass.'
- b. tówi-hp-òt wíkəwám-ək əté.  
through-eat-instrument house-LOC located-(3)  
'The table is in the house.'

The corresponding classes of transitive verbs are the Transitive Animate (TA) verbs, which take only grammatically animate objects, and the Transitive Inanimate (TI) verbs, which

take only grammatically inanimate objects. The examples in (2) are typical. The TA stem /nami-y-/ 'see' is used with animate objects, such as kò 'log' (pl. kówiyk). The TI stem /nami-ht-o-/ 'see' is used with inanimate objects, such as mìp 'leaf' (pl. mípiyil).

- (2) a. n<sup>ó</sup>mi-y-à                      k<sup>ó</sup>wi-hì.  
 (3)see-TA-DIR-(33.OBV) log-33.OBV  
 'He sees the logs.'
- b. n<sup>ó</sup>mi-ht-ó-n- l                      m<sup>í</sup>pi-hil.  
 (3)-see-TI-TI-3IN-33IN leaf-33IN  
 'He sees the leaves.'

Since Passasmaquoddy makes extensive use of "null anaphora," neither subjects nor objects need be phonetically overt. In fact verbs like wá-l-akísk-ət (good-day-II-(3)) 'it is a good day' and cków-ápan (hither-dawn-(3)) 'dawn is coming' never occur with overt subjects. Such verbs may nonetheless be classed as Inanimate Intransitive verbs on the basis of their inflection.<sup>3</sup>

AI and II stems typically come in pairs. (The exceptions are the II stems without overt subjects, which have no AI counterparts.) In some cases, the relationship between corresponding AI and II verbs is simply suppletive. This is true, for example, of the stems /əpi-/ and /əte-/ in (1). More frequently, the stems differ only in their "finals," stem-final morphological units which are single morphemes in the simplest cases but may also be morphologically complex. The stems shown in (3) differ only in their last morpheme: the final in (3a) is /-əsi-/ AI, while that in (3b) is /-ət-/ II. Although these two

suffixes typically form stative verbs, they are essentially formal elements with no concrete meaning. Other finals have more semantic import, as we will see below.

- (3) a. nāmèhs sáláwe-hpók-so.  
 fish salt-taste-AI-(3)  
 'The fish tastes salty.'
- b. píks-èy sáláwe-hpók-ət.  
 pig-meat salt-taste-II-(3)  
 'The pork tastes salty.'

In some cases, the suffix /-(ə)wi-/ is added to an AI stem to form the corresponding II stem:

- (4) a. málíhkí-kən-e skítap.  
 strong-nature(?)-AI-(3) man  
 'The man is strong.'
- b. málíhkí-kən-e-wì-w píye.  
 strong-nature(?)-AI-II-3 beer  
 'The beer is strong.'

A few finals derive both AI and II stems, so that paired stems of these two classes are not always distinct. Thus méhkw-éyi-t (red-AI/II-3AN) 'he who is red' and méhkw-éyi-k (red-AI/II-3IN) 'that which is red' are both based on the stem /mihkw-eyi-/. Both wécków-ya-t (hither-go-3AN) 'he is coming toward here' and wécków-ya-k (hither-go-3IN) 'it is coming toward here' are based on the stem /wəckəwi-ya-/.

TA and TI stems also typically come in pairs which differ only in their finals. The TA stem in (5a) is formed with the

final /-ahp-/ 'taste, eat,' while the TI stem in (5b) is formed with the synonymous final /-aht-əm-/ instead. As in the case of AI and II finals, these finals are distinguished only by the restrictions which they place on the grammatical gender of one argument of the verbs which they derive. Even though wínas 'stomach' can be used to refer to tripe, it cannot replace wínasèy 'tripe' in (5b), since wínas is an animate noun while wínasèy is inanimate.

- (5) a. n-wík-áhp-a      wínas.  
           1-like-taste-DIR stomach  
           'I like (the taste of) tripe.'
- b. n-wík-áht-əm-ən      wínas-èy.  
           1-like-taste-TI-3IN stomach-meat  
           'I like (the taste of) tripe.'
- c. \*n-wik-aht-əm-ən winas.

Many TI finals are morphologically complex, ending in one of the "thematic elements" /-o-/ ~ /-əw-/ or /-əm-/. (The first of these is illustrated in (2b), the second in (5b).) From a historical point of view, these morphemes can probably be analyzed as inanimate object markers. Since they now occur only with particular finals, however, and since inanimate objects are indicated elsewhere in the inflection of Passamaquoddy verbs, it seems better from a synchronic point of view to treat these elements as derivational suffixes. It is not always clear in particular cases whether they should be segmented as separate morphemes. For the most part, I have ignored /-o-/ in glossing examples and indicated the presence of /-əm-/ only where there



seems to be some synchronic evidence in favor of recognizing its continuing independence.

Double Object or TA+O verbs are used with two nominal complements. (Some in fact permit three.) Of these, one must be animate and is reflected in inflection in all paradigms. This is the primary object of the verb. A secondary object is reflected in inflection in some paradigms. It may be of either gender, but is always third person. Two typical examples are shown in (6).

- (6) a. k-míl-í-n-ək                      (nìl) ǎləmóss-ək.  
           2-give-1.OBJ-PEG-33PROX    me    dog-33PROX  
           'You (sg.) give me dogs.'
- b. n-kísi kík-a-h-á-n-əl              píyel kpíson-əl.  
           1-past heal-TA-DIR-PEG-33IN Peter medicine-33IN  
           'I healed Peter with medicines.'

In (6a), the primary object of kmílinək 'you (sg.) give them (an.) to me' is nìl 'me,' the logical goal. The secondary object is ǎləmóssək 'dogs,' the logical theme or patient. Both objects are reflected in verbal inflection in this case, the primary object by the suffix -i- 1.OBJ, the secondary object by the suffix -ək 33PROX. The primary object of nkísi kíkahanəl 'I healed him with them (in.)' in (6b) is píyel 'Peter,' the logical patient, while the secondary object is hpísonəl 'medicines,' the logical instrument. (The secondary objects of verbs of this type are what we might call "thematic instruments" -- instruments which reach and affect the patient.) Here the primary object controls the choice of the suffix -a-, while the secondary object is indexed in the verb by the suffix -əl 33IN. (I will return to

these inflectional affixes below.) Several other classes of double object verbs can be distinguished on the basis of the thematic roles of their complements. In one common type, for example, the primary object is the possessor of the secondary object. In a periphrastic causative construction, the primary object is the "causee" and the secondary object is a clause.

One final class of verbs have the gender-selection properties of AI verbs, and for the most part are based on AI stems, but nonetheless take a nominal complement which is not marked for locative case and which is reflected in verbal inflection like the secondary object of a TA+O verb. These are the Transitivity AI or AI+O verbs. Their complements typically bear thematic roles which are expressed in English by means of prepositions. Like the secondary objects of TA+O verbs, these complements may be of either gender but must be third person. The examples in (7) show /tehsakw-əpi-/ 'sit on' used first as an AI stem, then as an AI+O stem, with an animate complement in (7b) and an inanimate complement in (7c).

- (7) a. téhsák-w-ə-po síps-is skínohs-ís-əl w-éte-k.  
on.top-sit bird-DIM boy-DIM-3.OBV 3-belly-LOC  
'The bird is sitting on the boy's belly.'
- b. n-té<sup>h</sup>hák-w-ə-pi-né-nno-k ápasí-hik.  
1-on.top-sit-PEG-11-33PROX tree-33PROX  
'We (du. exc.) are sitting on the trees.'
- c. n-téhsák-w-ə-pi-né- nno-1 pənápsk-ol  
1-on.top-sit-PEG-11-33IN rock-33IN  
'We (du. exc.) are sitting on the rocks.'

There are no TI+O or II+O verbs which parallel the TA+O and AI+O forms shown above. Thus, for example, there is no alternative to (8) in which /tehsakw-ahte-/ 'be located on top' is used with a non-locative complement in place of máni-hik 'money (loc.).'

(8) wík-hí-ke-w-ey téhsakw-te máni-hik.

write-TA-AI-DA-NF on.top-located-(3) money-LOC

'The pencil is lying on the money.'

### 2.3 The structure of stems

A relatively small number of Passamaquoddy verb stems are synchronically unanalyzable. So, for example, /ate-/ II 'be located,' shown in (1), contains no independently occurring morphological elements. The stem /nəmiḱwəsi-/ ~ /məniḱwəsi-/ AI 'be born' may be historically a lexical passive of /nəmi-y-/ TA 'see,' but neither the meaning of the AI stem nor its variable form supports a synchronic analysis along these lines.

Analyzable verb stems, which are by far in the majority, consist of a sequence of an initial, optionally a medial or sequence of medials, and a final:

(9) Structure of verb stems:

Initial-(Medial)\*-Final-

The semantics of initials is extremely heterogeneous. Medials often have concrete meanings and frequently resemble nouns or noun finals (the latter are discussed below). Finals determine the transitivity and gender-selection class of the stem and may

add concrete elements of meaning as well, although many finals have abstract meanings or are simply formal elements with no clear semantic import.

The examples in (10)-(12) show pairs of verbs whose stems are formed with the same initials and finals. The first stem in each pair is made without a medial, while the second includes one. Note that the semantic contribution of the initial and final need not be the same in the two types of stems.

- (10) a. wá1-əpo  
good-sit-(3)  
'he sits nicely, comfortably; he is well off'
- b. wá1-əwé-po  
good-hair-sit-(3)  
'his hair is nicely fixed'
- (11) a. mí1-əcihté-t-ol  
various-color-3-33IN  
'they (in.) are of various colors'
- b. mí1-cək-əcíhte  
various-messy-color-(3)  
'it is multi-colored'
- (12) a. h-pásk-ə́n-a-1  
3-break-by.hand-DIR-3.OBV  
'he breaks the other with his hand'

b. h-pásk-əcək-ən-a-l

3-break-messy-by.hand-DIR-3.OBV

'he breaks the other (something squishy)  
with his hand'

The examples in (13) illustrate the use of sequences of medials.  
In each case, the medial elements are underlined.<sup>4</sup>

(13) a. áps-alək-sso

small-hole-AI-(3)

'it (an.) has a small hole in it'

b. cípək-alək-ətón-e

loud-hole-mouth-AI-(3)

'he is a loud-mouth'

c. h-pásk-ətóne-htá-h-a-l

3-break-mouth-strike-TA-DIR-3.OBV

'he hits the other, cutting the other's lip'

d. mákəsé-w-aləki-kwe-htá-h-a-l

(3)-dead.coal-DA-hole-face-strike-TA-DIR-3.OBV

'he gives the other a black eye'

Initials and finals may consist of a single morpheme, or they may be morphologically complex. An initial which consists of a single bound morpheme is a root. Thus wəl- 'good,' mil- 'various,' pásk- 'break,' áps- 'small,' and cípək- 'loud,' shown in (10)-(13), are roots. (The initial in (13d), mákəsé-w- 'black,' is not a root, since it is derived from the noun mákəs 'dead coal,' stem /mákəse-/, by the addition of the derivational affix /-w-/.)

Many complex initials and finals are derived from stems. The stem of the verb in (14a) appears as a complex initial in (14b). The stem of the verb in (15a) appears as an initial in (15b), and the stem of the verb in (15b) in turn appears as an initial in (15c).

- (14) a. nísi-katən  
 two-year-(3)  
 'it is two years'
- b. nísi-katən-e  
 two-year-AI-(3)  
 'he is two years old'
- (15) a. wícohké-m-a-l  
 (3)-help-TA-DIR-3.OBV  
 'he helps the other'
- b. wícohké-m-si-kw  
 help-TA-REFLEX-22  
 'help (du.) yourselves!'
- c. wícohké-m-sí-katən  
 help-TA-REFLEX-year  
 'the time comes when someone who has never  
 been willing to do things for himself finally  
 does so'

Examples (16) and (17) show a similar relationship between verb stems and complex finals. The stem of the verb in (16a) appears as a final in (16b). The stem of the verb in (17a) is used as a final in (17b).

- (16) a. lóhk-e (/əlohk-e-w/)  
 work-AI-(3)  
 'he works'
- b. wápal-əlóhk-e  
 improper-work-AI-(3)  
 'he does wrong, acts improperly'
- (17) a. ámik-ətákkó (/amihk-ətəkwkwí-w/)  
 up-jump-(3)  
 'he jumps up'
- b. kís-ámik-ətákkó  
 past-up-jump-(3)  
 'he jumped up'

The structure of noun stems is generally simpler than that of verb stems. Many noun stems are unanalyzable: tòhp 'alder' (underlying /tohpi-/), ákəm 'snowshoe,' pkásən 'shoe' (possessed máksən-əl ((3)-shoe-3.OBV) 'his shoe'). Others can be segmented like verb stems into an initial and a final. The root /mihkw-/ 'red' is combined with a final /-aksən/ 'shoe' in pkw-áksən 'red shoe.'<sup>5</sup> The stems /tohpi-/ and /akəm-/ are initials and /-ahtəkw/ 'stick' and /-ahkw/ 'wood' are finals in tóhpiy-ahtəkw 'alder pole' and ákəm-ahkw 'white ash' (literally "snowshoe wood"). (Compare the medial /-ahkw-/ 'wood, stick' in kín-áhkwi-sámaw-e (large-wood-horn-AI-(3)) 'he has big antlers.')

Like verbal initials and finals, initials and finals in noun stems may be simple or complex. The TA stem /təm-əh-/ 'cut in two' is combined with the noun final /-kən/, a general nominalizer, in təm-hí-kən 'axe.' The stem of təm-hí-kən can in

turn be used as an initial, as in tám-hi-kán-áhtakw 'axe handle.' The stem of ákam-ahkw appears as a complex final in káhk-ákam-ahkw 'brittle white ash.'

Not all complex noun stems can be analyzed as a sequence of an initial and a final. Even though they are inflected forms, verbal participles may be treated as noun stems in inflection for possession. Thus the participle nóci tkw-án-ke-t (occupation arrest-by.hand-AI-3AN) 'he who arrests as an occupation' = 'policeman' may be inflected as a possessed noun, giving nóci tkw-ánké-t-am-əl 'his policeman,' with the possessive suffix -am and the obviative singular suffix -əl. Many nouns which appear to be former participles are not synchronically related to any verb but nonetheless continue to be inflected like verb forms with analyzable suffixes. For example, éhpit 'woman' has obviative forms with -li-, otherwise an agreement suffix of verbs, even though there is no verb stem \*/ehpi-/: éhpi-lí-c-il 'woman (obv.),' éhpi-li-c-ihì 'women (obv.).' (The verbal suffix /-t/ 3AN is regularly palatalized to /-c-/ before the participle endings which begin with /i/. See 6.6.2 for discussion.)

Both verb stems and noun stems may be preceded by loosely joined modifiers known as preverbs and prenouns, many of which are related to verbal and nominal initials. These modifiers are treated as a unit with the word which they modify in inflection and in Initial Change, but may be separated from the modified word by other material within a clause. This usage is particularly common with certain preverbs, such as /əli/ 'thus, there' (Changed form /eli/: éli n-kwəss kəti sákamá-wi-t (thus 1-son future governor-AI-3AN) 'because my son was going to be



(tribal) governor.' A noun together with any preceding pre-nouns is a noun complex; a verb together with any modifying preverbs is a verb complex.

## 2.4 The inflection of nouns

Passamaquoddy nouns are inflected for gender, number, obviation, absentativity, and locative case. Possessed nouns are also inflected for the person and number of the possessor. A few nouns have special vocative forms and nouns which are used as vocatives are pronounced with a distinctive intonation pattern.

Gender is animate or inanimate, as discussed in section 1. Number in nouns is singular or plural. (A dual/plural distinction is made in AI verbs through the use of explicitly plural stems: non-singular AI forms based on stems which are not inherently plural in meaning are normally understood as duals.) The categories of obviation and absentativity require special comment.

If there is only one third person noun or pronoun (expressed or implicit) within a context, this third person is proximate. When there is more than one third person within certain close contexts, one must be selected as proximate; all others are obviative. Thus in (18a) the subject of the verb, pílskwéhsis 'girl,' is proximate, so the object, skínohsísəl 'boy,' is obviative, as shown by the use of the obviative singular suffix -əl. In (18b) the subject, míhtákwsəl 'his father,' is obviative and the object, wásis 'child,' is proximate.

- (18) a. pílskwéhs-is h-kísi ták- m-a-l skínohs-ís-əl.  
 girl-DIM 3-past hit-TA-DIR-3.OBV boy-DIM-3.OBV  
 'The girl hit the boy.'
- b. míhtákws-əl h-ták-am-əko-l wás-is.  
 (3)-father-3.OBV 3-hit-TA-INV-3.OBV child-DIM  
 'The child's father hit him.'

Within a single context of obviation, all nouns or pronouns which are coreferent with a proximate third person will also be proximate.

The third person which is selected as proximate is apparently the discourse topic or in some other sense relatively prominent, while obviative third persons have a secondary status in the discourse; but the precise nature of the distinction or distinctions expressed by means of obviation remains poorly understood. Since an obviative expression is formally secondary to some other third person in a context, I will frequently use forms of "the other" to indicate obviatives in glosses.

The contexts within which obviation is figured are determined by both grammatical and discourse factors, which are again for the most part poorly understood. Only one proximate third person is allowed within a clause, except in the case of conjoined third persons, where all of the conjuncts may be proximate, the conjunction as a whole functioning as a unit in the system of obviation. Individual clauses within a complex sentence are sometimes treated as separate obviation domains. On the other hand, a sequence of sentences in discourse is sometimes treated as a single domain, so that all of the third persons

within a single sentence in discourse may be obviative. (Carrying over obviation across sentence boundaries in this way appears to be relatively uncommon, however.) A special grammatical provision makes any noun obviative if it has a third person possessor, regardless of the relative discourse status of the two expressions. (Nouns which are grammatically obviative but not obviative by virtue of their status in discourse are sometimes treated like proximate nouns in verb agreement.)

Obviation is morphologically expressed in noun inflection only for animate nouns, although a few little used verb forms indicate obviation for inanimate subjects: skà pənápsk-ol pc-íhtó-h-olí-h-kw (not rock-3IN accidentally-strike-TA-OBV-NEG-3NEG) 'if the rocks (obv.) do not strike him (prox.),' with the suffix -olí- indicating that the subject of the verb is obviative.

Absentative inflection is used to indicate several types of distance or absence. Nouns which refer to living beings may be used in an absentative form to indicate that the referent of the noun has died: ətóhk 'deer,' ətòhk (deer-(3AN.ABS)) 'deer (dead)'; n-ítap (1-friend) 'my friend,' n-ítapì (1-friend-(3AN.ABS)) 'my late friend.' Any noun may be used in an absentative form to indicate that the referent was recently present but is now absent:

(19) táma níhtəl htáma-w-éya-kəl?

where those(in.) smoke-DA-NF-3IN.ABS

'Where are those (boxes of) tobacco

(that were here before)?'

Nouns may also be used in absentative forms to indicate that ownership has ceased: n-míhkwátakən (1-knife) 'my knife,' n-míhkwátakən (1-knife-3IN.ABS) 'the knife that I used to own'; h-témis-ə1 (3-dog-3.OBV) 'his dog,' h-témis-kə1 (3-dog-3.OBV.ABS) 'the dog that he used to own.'

Gender, number, obviation, and absentativity are marked together in noun inflection by means of the following suffixes, shown here in their underlying forms. (The underlying form /-ə/ for the obviative plural suffix is speculative. Abstract final vowels -- perhaps empty V-slots -- are postulated for two of the absentative singular suffixes to account for the phonological treatment of stem-final vowels before these endings.)

(20) Suffixes marking nominal categories

	Non-absentative	Absentative
Animate		
Prox. sg.	/-ə/	/-(w)V/
Obv. sg.	/-ə1/	/-kə1/
Prox. pl.	/-ək/	
		/-əkk/ ~ /-kəkk/
Obv. pl.	/-ə/	
Inanimate		
Sg.	/-ə/	/-(w)V/
Pl.	/-ə1/	/-kə1/

The /w/ of the absentative endings with the form /-(w)V/ is used after /a/ (and sometimes after /e/): htámá-w-eyá-w (smoke-DA-NF-3IN.ABS) 'tobacco (abs.).' The suffixes /-əl/, /-ək/, /-kəl/, /-ək/, and /-kək/ have the variants /-il/, /-ik/, /-ikəl/, /-ikk/, and /-ikək/, respectively, in participles and nouns historically derived from participles: éhpi-c-ikk 'women (abs., prox. or obv.).' (A good deal of other variation, particularly in absentative forms, is ignored in this discussion.)

The paradigms given in (21) and (22) illustrate the surface forms of the suffixes in (20) in combination with the stems /əpəsi-/ A 'tree' and /əpəsi-/ I 'stick.'<sup>6</sup>

(21) / p si-/ A 'tree'

prox. sg.	ápəs
obv. sg.	əpəsiyil ~ əpəsihil
prox. abs. sg.	əpəsi
obv. abs. sg.	əpəsikəl
prox. pl.	əpəsiyik ~ əpəsihik
obv. pl.	əpəsi
abs. pl.	əpəsikk

(22) /apasi-/ I 'stick'

sg.	ápàs
abs. sg.	ápàsì
pl.	ápàsíyil ~ ápàsíhil
abs. pl.	ápàsikàl

Possessed nouns are inflected for the person and number of the possessor. Inherently possessed or dependent nouns occur only with such inflection (except that a few dependent nouns occur uninflected as vocatives: kwáss 'son, young man (voc.)', tós 'daughter, young woman (voc.)'). The person of the possessor is marked by one of three personal prefixes: if the possessor includes the second person, the prefix /k(t)-/ is used; if the possessor includes the first person but not the second, the prefix /n(t)-/ is used; if the possessor is third person, the prefix /w(t)-/ is used. The forms of the prefixes without /t/ are used before (underlying) non-syllabics, the forms with /t/ before vowels, except in dependent nouns, where the forms without /t/ are used before vowels as well: n-kát 'my leg,' nt-ákam 'my snowshoe,' n-ítap 'my friend.' The /w/ of the third person prefix is deleted before non-syllabic sonorants and realized as h before obstruents in most environments. (See 5.3 for discussion.) The person of the possessor is marked again by suffixes which indicate plural possessors: if the possessor is plural and includes the first person, the suffix is /-nno-/ (/ -n/ in final position); if the possessor is plural and does not

include the first person, the suffix is /-wa/: n-ítapé-nno-k 'our (exc.) friends,' k-ítapé-wa-k 'your (pl.) friends.' The suffix /-nno-/ has an alternate form /-nəw-/ (also /-n/ in final position) which is normally used with certain dependent nouns but otherwise appears to be archaic. The fact that second person is marked in preference to first in prefixation but not in suffixation results in a distinction between inclusive and exclusive first person plural possessors: k-ítapé-nno-k 'our (inc.) friends.' Both /-nno-/ ~ /-nəw-/ and /-wa/ are preceded by an epenthetic /ə/ after a non-syllabic, presumably through the application of the rule of epenthesis discussed in 7.1.

Part of the possessed paradigm of the dependent noun /-tos/ 'daughter' is shown in (23). Note that the suffixes which indicate person and number of the possessor form an inner layer of inflection, which is followed by a second layer of suffixes, those which mark the nominal categories of the possessed noun itself. Not shown here are the obviative forms for first and second person possessors, which would be used in a context which includes another third person nominal.

(23) /-tos/ A (dependent) 'daughter'

Sg. 1	n-tós	11	n-tós-ə̀n
2	k-tós	12	k-tós-ə̀n
3	h-tós-ə̀l	22	h-tós-ə̀wa
		33	h-tós-ə̀wa-l

Pl. 1	n-tós-ək	11	n-tós-ənów-ək
	2 k-tós-ək	12	k-tós-ənów-ək
	3 h-tòs	22	k-tós-əwà-k
		33	h-tós-əwà
Abs. Sg. 1	n-tòs	11	n-tós-ənò
	2 k-tòs	12	k-tós-ənò
	3 h-tós-kəl	22	k-tós-əwàw
		33	h-tós-əwà-kəl
Abs. Pl. 1	n-tós-kək	11	n-tós-ənò-kk
	2 k-tós-kək	12	k-tós-ənò-kk
	3 h-tós-kək	22	k-tós-əwà-kk
		33	h-tós-əwà-kk

Possessed forms of some nouns are based on a possessed theme rather than directly on the stem. This theme is derived from the stem by the addition of a possessive suffix /-m/ or /-om/ (glossed "POSS"): ht-əpəsi-m-əl (3-tree-POSS-3.OBV) 'his tree.' With some nouns the use of a possessive suffix is optional: ht-ótèn ~ ht-óténe-m 'his town,' stem /otene-/. Dependent nouns do not usually take a possessive suffix.

The suffix /-k/ (/ik/ for nouns derived from participles) makes locative forms of nouns: əpəsi-k 'tree, stick (loc.),' n-ík-əno-k (1-house-11-LOC) 'our (exc.) house (loc.).' The



spatial notion implied by the use of the locative suffix is quite general. More precise specification is often provided by the use of a particle: kwihiw sópék-ok (nearby sea-LOC) 'near the sea.'

The locative suffix and the outer-layer suffixes which mark the grammatical categories of the base noun are mutually exclusive. Thus locative nouns are not marked for gender, obviation, or absentativity: ht-ápasi-m-awa-k (3-tree-POSS-33-LOC) 'their tree (loc.),' cf. ht-áp sí-m-awa-l (3-tree-POSS-33-3.OBV) 'their tree,' with the obviative singular suffix /-əl/. Plural number is indicated for locative nouns by the use of a suffix /-hko-/: ápasi-hko-k 'trees, sticks (loc.).' The material which precedes this suffix is treated like the base for the addition of a derivational affix, adding /i/ if it ends in a non-syllabic, /wi/ if it ends in a vowel other than /i/: pskihkwí-hko-k '(blades of) grass (loc.),' póhtáyawí-hko-k 'bottles (loc.)' (stems /pskihkw-/, /pohtaya-/).<sup>7</sup>

Possessed forms of nouns are sometimes made with repetition of the suffix which marks person and number of the possessor: w-ík-awa ~ w-ík-awa-wa (3-house-33-33) 'their house.'<sup>8</sup> When the first person plural suffix is repeated in a formation of this type, the first occurrence of the suffix is a variant of /-naw-/, the second a variant of /-nno-/: k-ík-an-àn (2-house-11-11) 'our (inc.) house,' k-ík-an-ánno-l (2-house-11-11-33IN) 'our (inc.) houses.' Locative forms derived from such multiply marked possessives are sometimes interpreted as plural: k-ík-an-ánno-k (2-house-11-11-LOC) 'our (inc.) houses (loc.).' Plural locative forms of this type have the plural locative element /-hko-/

between occurrences of the person/number markers. Such forms generally have a distributive sense:

(24) a. skínohs-ís-ə̀k      ápaté-pə-w-ə̀k  
 boy-DIM-33PROX      lean-sit-3-33PROX

ht-ápasí-m-ə̀wáwi-hkó-wa-k.  
 3-tree-POSS-33-PL-33-LOC

'The boys (du.) are sitting and leaning against  
 their trees, each against his own tree.'

b. máciy-alə̀kíttiy-ápasí-ne      k-ík-ə̀nówi-hkó-nno-k.  
 start-intensive-pl.walk-11 2-house-11-PL-11-LOC

'Let's get the hell out of here, each of us going  
 to his own house!'

A few nouns have special vocative forms: n-òhkəm-í (1-grandmother-VOC) 'my grandmother!' (cf. n-óhkəməss (1-grandmother) 'my grandmother'), wás-is-tók (child-DIM-VOC.PL) 'children!' (cf. wás-ís-ə̀k (child-DIM-33PROX) 'children'). Both these nouns and others which do not have special vocative forms are pronounced with a distinctive pattern of stress and intonation when used as vocatives: ə̀hpít 'woman!' (cf. éhpit 'woman').

## 2.5 The inflection of verbs

With the exception of a few defective verbs, every verb in Passamaquoddy is inflected in some fifty paradigms. On the basis of formal similarities and, to some extent, shared syntactic

distributions, these paradigms are grouped into three orders: Independent, Conjunct, and Imperative. The Independent and Conjunct Orders are each divided into several modes. Within each mode, several tense/aspect distinctions are made. (The principal distinctions are between an unmarked tense, a preterite, and a dubitative or non-personal-knowledge form. Future tense is indicated by means of a particle ə̀c or òhc, which may be suffixed to any word as -hc, -c after non-syllabics. There is also a conditional particle ə̀p with a suffixed form -(h)p.) Each tense/aspect paradigm in turn has distinct sets of positive and negative endings. Positive and negative endings are also distinct in the Imperative Order, but there is only a single mode in which no tense or aspect distinctions are made. Imperative forms are considerably more heterogeneous than those of the other orders. Negative imperative and "hortatory" or third-person imperative forms resemble forms of the Conjunct Order.

### 2.5.1 Passamaquoddy verb modes

Independent and Conjunct forms have different syntactic distributions. As a first approximation, we may say that Independent forms are used in main clauses and Conjunct forms in subordinate clauses. Thus the first verb in (25a) is a Conjunct form, the second an Independent form. But in (25b), where two main clauses are conjoined, both verbs are Independent forms.

(25) a. *Étəl-əlohk-é-t-pən, wəl-ápesó-hpən.*  
 ongoing-work-AI-3AN-PRET good-paid-(3)-PRET  
 'When he was working, he was well paid.'

b. *təl-lohk-é-hpən náka óli*  
 ongoing-work-AI-(3)-PRET and (3)-good  
  
*pkwá-hto-n mən.*  
 earn-TI-SUBORD money

'He was working and making good money.'

Independent forms are used in certain types of subordinate clauses, however, and Conjunct forms are sometimes found in main clauses. Complements of verbs of wanting, for example, use Independent verb forms, as shown in (26), and the Conjunct may replace the Independent in (27a), apparently with a difference in sense:

(26) *n-páwa-t-əm-ów-a-n nt-əpkwehsím-ohtá-ko-n*  
 1-want-TI-TI-TA-DIR-PEG 1-rest.head-TA-INV-SUBORD  
  
*náka h-kówi-n.*  
 and 3-sleep-SUBORD

'I want him to lay his head down on me and go to sleep.'

(27) a. cków-ye            píyel.

hither-go-(3) Peter

'Peter is coming toward here.'

(He is on his way, but could be any distance away.)

b. wécków-ya-t        píyel.

hither-go-3AN Peter

'Peter is coming toward here.'

(e.g. coming down the road -- you can see him)

Both the Independent Order and the Conjunct Order are divided into modes which again have somewhat different syntactic distributions. The Independent Order includes an Indicative Mode and three Subordinative Modes. (The latter are formally similar and might be classified as three submodes of a single mode.) The Conjunct Order includes three modes whose forms are made with Initial Change, a modification of the first vowel of the verb complex, and one Unchanged mode. The Changed modes are the Changed Indicative, the Changed Subjunctive, and the Participle. The Unchanged mode is the Unchanged Subjunctive.<sup>9</sup>

The Independent Indicative is the principal mode used in independent main clauses or main clauses which begin a discourse. Clauses which state propositions which are taken to follow temporally or logically on some other statement typically have verbs which are inflected in the primary Subordinative mode (the Subordinative I). In a sequence of conjoined clauses, the first typically contains an Independent Indicative form, the others a Subordinative I form:

- (28) a. *cílk-ensk-ǎso*      *náka h-kín-apsk-ǎsi-n.*  
 short-body-AI-(3) and 3-large-round-AI-SUBORD  
 'He is short and fat.'
- = b. *kín-apsk-ǎso*      *náka h-cílk-ensk-ǎsi-n.*  
 large-round-AI-(3) and 3-short-body-AI-SUBORD  
 'He is fat and short.'<sup>10</sup>

Both verbs in the conjoined subordinate clauses in (26) are Subordinative I forms. This mode is also used in purpose clauses and in complement clauses in causative constructions, while the Independent Indicative is used in subordinate clauses with the preverb hsámi 'because.' Both the Indicative and the Subordinative I occur in questions with táma 'where, somewhere.' Questions with táyawe 'when, sometime' use the Indicative, while questions with tán 'how' require the Subordinative I.

The Subordinative II may be used in main clauses in place of the Indicative, but appears to have a different aspectual sense. The same aspectual meaning may be expressed in third person forms by the use of absentative inflection, which in this usage does not imply an absentative reading for the nominal indexed by the absentative agreement marker. The verb in (29a) is an Independent Indicative form formally inflected for a proximate animate absentative singular subject (suffix -a); (29b) is essentially equivalent in meaning but has a verb inflected in the Subordinative II.

(29) a. nékəm tē-hp      tk-áhsəmo-w-à

he      EMPH-COND cold-swim-3-3AN.ABS

skàt tóci      tk-éyi-nòhk      hsámákwan.

not      extreme cold-II-3IN.NEG water

'He would have gone swimming if the water had not  
been so cold.'

b. nékəm tē-hp      h-táhk-áhsəmi-nè

he      EMPH-COND 3-cold-swim-SUBORD-(ASPECT)

skàt tóci      tk-éyi-nòhk      hsámákwan.

not      extreme cold-II-3IN.NEG water

'He would have gone swimming if the water had not  
been so cold.'

The endings of the Subordinative II resemble absentative object forms of the TI and AI+O paradigms and may reflect a reanalysis of such forms which led to the creation of a new aspectual paradigm. Note, for example, the final w of the verb in (30b) which is lacking in the Subordinative I form in (30a) and is reminiscent of the w which is added to noun stems ending in /a/ in absentative singular forms. (Subordinative I forms may be used as futures and as polite commands. The latter usage is reflected in (30a).) I will assume here that the last morpheme of the Subordinative II endings is an abstract aspectual suffix which triggers allomorphy in certain preceding morphological elements. This suffix is also presumably responsible for the grave accent on the final syllable of these forms, another

respect in which they resemble absentatives. (See 3.5 for a discussion of the accentual contrasts of Passamaquoddy.)

(30) a. kíləwəw k-táhk-ahsəmi-ni-ya  
you(pl.) 2-cold-swim-SUBORD-22

kwéni nílòn óténe-kási-yek.  
length we(exc.) town-AI-11

'You (du.) go swimming while we (du. exc.) go shopping in town.'

b. kíləwəw əp k-táhk-ahsəmi-ni-yəw  
you(pl.) COND 2-COLD-SWIM-SUBORD-22-(ASPECT)

skàt kəmiwəw-onòhk.  
not rain-3IN.NEG

'You (du.) would have gone swimming if it had not rained.'

The Subordinative III appears to be used primarily with the particle táne(hk) 'ever since,' but seems to be interchangeable with the Subordinative II in this use. All Subordinative III forms end with a suffix -hk:



(31) a.                     $\left. \begin{array}{l} \text{k-táh-k-áhsami-ni-yàw} \\ \text{k-táh-k-áhsami-ni-yà-hk} \end{array} \right\} \begin{array}{l} \text{tane-hk} \\ \text{how-ASPECT} \end{array}$                      $\left. \begin{array}{l} \text{2-cold-swim-SUBORD-22-ASPECT} \end{array} \right\}$

ánsa kt-áli-nó-l-pa                    nǎméhs-ək.  
 like 2-thus-look-2.OBJ-22 fish-33PROX

'Ever since you (du.) first went swimming, you  
 have looked like fish to me.'

The system of vowel mutations which distinguishes the three Changed modes of the Conjunct Order from the Unchanged Subjunctive is discussed in detail in Chapter 9, where a few additional examples of the use of these modes are also given. Here we may simply note that the Changed Indicative and Changed Subjunctive are both frequently used in subordinate clauses which translate into English as "when," "while," or "as" clauses. The Subjunctive forms appear to end in an abstract vocalic element. I will argue in 10.3 that this suffix consists only of an empty V-slot. Changed Subjunctives appear to have a perfective meaning, while Changed Indicatives are imperfective. I therefore gloss the abstract final suffix of the Subjunctives as "PERF." The examples in (32) show first a Changed Indicative form of /ǎlami-ya-/ 'go away,' then a corresponding Changed Subjunctive (that is, perfective) form:

(32) a. má te námi-y-óko-w-ən éləmi-ya-yek.

not EMPH (1)-see-TA-INV-11 away-go-11

'He did not see us (exc.) as we (du. exc.) left.'

b. má te námi-y-okó-w- n éləmi-ya-yèk.

not EMPH (1)-see-TA-INV-NEG-11 away-go-11-(PERF)

'He did not see us (exc.) when we (du. exc.) left.'

Participles are used in relative structures and in content questions with forms of wèn 'someone, who' and kèkw 'something, what.' The latter are probably best analyzed as equational structures containing a headless relative clause. A set of participle suffixes marks the nominal categories of the semantic head of the relative clause, animate, obviative, and singular in (33a,b).

(33) a. ətóhk n-tátat néhpa-h-á-c-il

deer 1-father kill-TA-DIR-3AN-3.OBV

kə̀màc kín-kil.

very large-size-(3)

'The deer that my father killed is very big.'

b. nékam téhsákw-ə̀pə pém-ákw-ə̀pi-lí-c-il

he on.top-sit-(3) along-wood-sit-OBV-3AN-3.OBV

stáhkwan-ok.

tree-LOC

He is sitting on a tree which is lying on the ground.'

Participles are also sometimes used in main clauses in place of Changed Indicative forms in sentences like (27b) above. Conversely, Changed Indicative forms (that is, forms lacking participle suffixes) are sometimes used in place of participles in relative clauses and questions.

Unchanged Subjunctive forms, like Changed Subjunctive (perfective) forms, are made with a final abstract suffix, which I gloss as "SUBJ." They are used in various types of conditional ("if") clauses:

(34) má tè-hp nāmí-y-okò

not EMPH-COND (1)-see-TA-INV-(NEG)

álamí-ya-yan sítəm-ək.

away-go-1-(SUBJ) shore-LOC

'He would not see me if I went down to the shore.'

The single mode of the Imperative Order consists of a heterogeneous set of forms which are used in various kinds of direct and indirect commands:

- (35) a. wícohkè-m-s  
 help-TA-REFLEX  
 'help yourself!'
- b. mósa míl-á-hk-ekw  
 don't give-DIR-NEG-22  
 'don't (pl.) give it to him!'
- c. mós-oc  
 cut-hair-UNSPEC/3(3)  
 'have him get his hair cut!'

## 2.5.2 General characteristics of inflection in the various modes

The inflection of verbs in the Independent Order resembles that of possessed nouns, although there are a number of differences as well, notably the fact that /pən/ 11 and /-pa/ 22 are used in place of /-n/ ~ /-nno-/ 11 and /-wa/ 22 at various points in the Indicative paradigms and that /-wa/ as a third person plural marker is restricted to proximates. A suffix /-w/ indexes third person subjects in AI and II Indicative forms, but occurs on the surface in word-final position only after i. (For some discussion of the phonology of third person forms with /-w/, see 4.6 and 8.1.3.) The personal prefixes are used, sometimes as subject markers, sometimes as object markers: if either the subject or the primary object (if any) of a verb includes the second person, the prefix /k(t)-/ is used; if either the subject or the primary object includes the first person but not the

second, the prefix /n(t)-/ is used; the prefix /w(t)-/ is used in some forms which involve only third persons, but the use of this prefix varies with the gender-selection and transitivity class of the verb. (No prefix is used in II inflection in any mode. The third person prefix is not used in the Independent Indicative of AI verbs and is optional, although preferred, in AI+O Independent Indicative forms. The third person prefix is never used in unspecified subject forms, whether transitive or intransitive.) As in noun inflection, the prefix allomorphs with /t/ are used before vowels, the allomorphs without /t/ before non-syllabics.

The three Subordinative modes use endings which include a mode marker /-n/ or /-ne/. In the Independent Indicative, a homophonous element is used in TA inflection as an inanimate subject marker and in TI inflection as an inanimate object marker. Another element with the same form appears in Independent forms which are inflected in agreement with a secondary object (AI+O and TA+O verbs). Here the suffix appears to be purely a structural element or "peg" morpheme with no specific meaning. Examples of /-n/ ~ /-ne/ in various formations are given in (36). (An epenthetic /ə/ is added before /-ne/ (36d), where it follows a non-syllabic.) In Subordinative forms with inanimate subjects or objects or with inflection for a secondary object, where one might expect two occurrences of /-n/ ~ /-ne/, only one is found. Examples (25b) and (26) contain Subordinative forms of this type.

(36) a. nílon̄ n-kássa-hà-pən náka nt-ápi-nè-n.  
 we(exc.) 1-in-go-11 and 1-sit-SUBORD-11  
 'We (du. exc.) came in and sat down.'

b. wísək-ihpáso, an n-kácicí-y-a-n  
 very-hot-(3) then 1-know-TA-DIR-SUBORD

élí ksinóhka-t.

thus sick-3AN

'He had a fever, and so I knew he was sick.'

c. hpíson mémhowiw wícohké-m-ko-n.  
 medicine extremely (3)-help-TA-INV-3IN

'The medicine helped him a lot.'

d. má te námi-htó-w-ane-wí-pən-il  
 not EMPH (1)-see-TI-NEG-3IN-NEG-PRET-33IN

təkèc kàhk námi-htó-n-əl.

now EMPH (1)-see-TI-3IN-33IN

'I didn't see them (in.) then, but now I do.'

e. k-ót-owhém-i-né-nəw-ək nánəw-ək psówis- k.  
 2-3-pet-AI-PEG-11-33PROX five-33PROX cat-33PROX

'We (du. exc.) have five cats as pets.'

f. nt-ih-m-a-kó-n-əl nt-ápkw-ásək-ih-íkən-əl.  
 1-have-TI-TA-INV-PEG-33IN 1-open-lock(?)-TA-NOM-33IN

'He has my keys.'

The combination of /-ne/ with the agreement suffix /-wa(w)/ 22 or 33PROX is realized as surface -niya(w). See 8.1.3. for discussion.

The morphology of the Conjunct and Imperative Orders is quite different from that of the Independent modes. No prefixes are used, and apart from the participle suffixes the endings of these orders bear little resemblance to the suffixes used in noun inflection. The agreement markers which are used in Conjunct inflection are more diverse and less regularly distributed than those of the Independent Order, and a number of those used with TA verbs are portmanteau morphemes which index both the subject and the object of the verb.

Many of the Imperative forms which make reference to a third person subject resemble the corresponding forms of the Conjunct Order; but a final /t/ or /k/ in the Conjunct forms is typically replaced by /c/ in Imperatives:

(37) a. wéckow-yá-hti-t                      n-ítàp.

hither-go-33PROX-3AN      1-friend

'My friend is coming here with someone (a member of his family).'<sup>11</sup>

b. cków-yá-hti-c

hither-come-33PROX-3

'have them (du.) come here!'

Third person Imperative forms also share syntactic properties with Conjunct forms, since they may appear in subordinate clauses which are complements to verbs of commanding:

- (38) yáh-à-n      náci-pto-c máni-m.  
tell-DIR-2 go-carry-3 (3)-money-POSS  
'Tell (sg.) him to go get his money!'

### 2.5.3 Aspects of TA and TA+O inflection

Since both subjects and objects are reflected in verb inflection, the most complex verbal paradigms in Passmaquoddy are those of the TA and TA+O verbs. One of the characteristic features of these paradigms is the use of a set of suffixes known as theme signs which occupy the innermost suffix position, immediately following the stem. The use of the theme signs is partially governed by the relationship between the subject and the (primary) object of the verb in terms of a hierarchy which involves person, gender, and obviation: first and second persons outrank third, animates outrank inanimates, and proximate animates outrank obviative animates. If the subject outranks the object on this hierarchy, the form is direct. If the object outranks the subject, the form is inverse. (If both the subject and the object are animate obviatives, the form may be either direct or inverse.)



(39) Hierarchy of persons, gender, and obviation

DIRECT -->

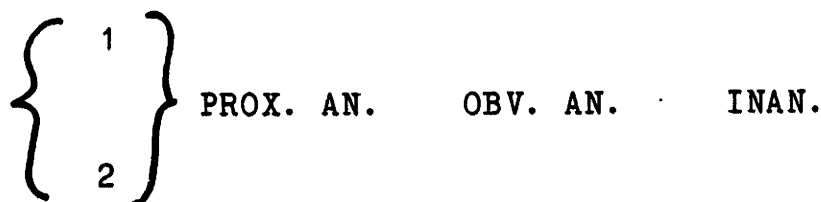

<-- INVERSE

The terms "direct" and "inverse" are appropriate for these categories, since the roles of the personal prefixes, the gender/number suffixes, and an outer layer of suffixes marking the grammatical properties of third person participants are reversed in the two sets: the morphemes which agree with the subject in direct forms agree with the object in inverse forms, and vice versa.

In the Independent Order, direct forms are made with a suffix /-a/, while inverse forms instead take /-ko-/ ~ /-kw/. The inverse marker is preceded by an epenthetic /ə/ or /o/ under conditions discussed in Chapter 7. Forms with unspecified subject and third person object resemble direct forms, since they are also made with a suffix /-a/, but the two /-a/ suffixes are treated differently in the assignment of word intonation. (A distinctive low pitch is associated with the /-a/ of unspecified subject forms in final syllables when no other pitch assignment rule takes precedence.) Forms with unspecified subject and first or second person object resemble inverse forms, taking a suffix /-ke/ which is preceded by epenthetic /ə/ or /o/ on the same pattern as /-ko-/. Bloomfield refers to unspecified subject

forms as "passives," and I will adhere to this terminology in glossing the theme sign /-a/ of unspecified subject forms as "3PASS" and the theme sign /-ke/ as "PASS." The English passive also provides a convenient translation for unspecified subject forms in many cases. These glosses are not intended, however, to imply any conclusions about the syntactic analysis of unspecified subject forms.

Examples of the use of these theme signs are given in (40). Note that the second person prefix /k-/ indexes the subject of the direct form (40a) but the object of the inverse form (40c), while the first person prefix /n-/ indexes the object of the unspecified subject form (40d). The person/number markers /-nno-/ 11 and /-wa/ 22 also index the subject in (40a) but the object in (40c) and (40d). The proximate plural suffix /- k/, on the other hand, agrees with the object in (40a) but the subject in (40c). In TA+O forms like (40d), the outermost suffix is an agreement marker for the secondary object, here /- l/ 33IN. (The reduction of /-ək/ and /-əl/ to -k and -l in forms like those shown here is discussed in 8.1.3.)

- (40) a. k-námi-y-á-nno-k  
 2-see-TA-DIR-11-33PROX  
 'we (inc.) see them'
- b. nāmi-y-â  
 see-TA-3PASS  
 'he is seen'
- c. má te k-námi-y-óko-wí-wa-k  
 not EMPH 2-see-TA-INV-NEG-22-33PROX  
 'they do not see you (pl.)'
- d. n-míl-ke-né-nno-l  
 1-give-PEG-11-33IN  
 'they (unspec.) give them (in.) to us (exc.)'

Forms with first person subjects and second person objects and forms with second person subjects and first person objects differ in structure from both direct and inverse forms. The prefix is /k(t)-/ for forms of both types. When the object is first person, the theme sign /-i/ is used. When the object is second person, the theme sign is /-l/ (with variants /-əl/ and /-ol/ as a result of epenthesis.) I gloss /-i/ as a first person object marker and /-l/ as a second person object marker, rather than taking these morphemes to index both subject and object in some fashion, since these or related morphemes are used in some Conjunct and Imperative forms with third person subjects. Examples of Independent forms with these theme signs are given in (41).

- (41) a. má te k-námí-y-ì-h-pān  
 not EMPH 2-see-TA-1.OBJ-NEG-11  
 'you (sg. or pl.) do not see us (exc.)'
- b. má te k-námí-y-ol-óh-pa  
 not EMPH 2-see-TA-2.OBJ-NEG-22  
 'I did not see you (pl.)'

There are no TA forms which express reflexive or reciprocal action. Instead, AI derivatives of the appropriate TA stem are used, formed with the finals /-si-/ REFLEX and /-ti-/ RECIP. Some discussion of reflexive and reciprocal forms will be found in 6.6.1 and 7.2.

The direct theme sign /-a/, the inverse marker /-ko-/, and the "passive" suffix /-ke/ are used in the Conjunct and Imperative Orders as well as in the Independent Order, but with somewhat different distributions. There is a good deal of variation in the form of the endings for the more marked combinations of subjects and objects. Conjunct forms with /-a/, /-ko-/, and /-ke/ are given in (42), Imperative examples in (43). (Example (43b) was provided by a Maliseet speaker. Since Imperative forms with third person subjects are particularly variable, this form may well diverge from typical Passamaquoddy usage.)

- (42) a.  $\acute{n}\acute{e}m\acute{i}-y-\underline{a}-t$   
 see-TA-DIR-3AN-(PERF)  
 'when he saw the other'
- b.  $sk\grave{a}t\dots pc-\acute{i}ht\acute{o}-h-\underline{ok\acute{o}}-li-hti-h-kw$   
 not accidentally-strike-TA-OBV-33PROX-  
 NEG-3NEG-(SUBJ)  
 'if the other does not accidentally hit them'
- c.  $sk\grave{a} l-\acute{a}p-\acute{a}m-\underline{a}ke-w-\grave{a}n$   
 not thus-look-TA-PASS-NEG-1-(SUBJ)  
 'if I am not looked at'
- (43) a.  $m\acute{i}l-\underline{a}-n$   
 give-DIR-2  
 'give (sg.) it to him/them!'
- b.  $\acute{e}wep-\acute{a}n-\underline{a}ko-c$   $t\acute{o}wi-hp-\grave{o}t.$   
 up-by.hand(?)-INV-3 through-eat-instrument  
 'Have the table hold you up.'
- c.  $n\acute{a}t-\acute{a}k\acute{e}him-\underline{k}\acute{e}-ne$   
 go-teach-PASS-11  
 'let's go to school!'  
 (literally "let's go be taught")

The direct theme sign is not used before vowel-initial suffixes of the Conjunct Order, but does appear before non-syllabics in related forms. Thus /-a/ is not used in (44a) where it would be followed immediately by the second person singular TA suffix /-ət/, but we do find /-a/ in (44b), where the negative morpheme /-w-/ precedes /-ət/.

- (44) a. némi-y-ət  
 see-TA-2/3(3)-(PERF)  
 'when you (sg.) saw him/them'
- b. wéci skàt tóhki-m-á-w-ət  
 from not awake-TA-DIR-NEG-2/3(3)  
 'so that you (sg.) do not wake him/them up'

Conjunct forms for unspecified subject and third person object are made with a suffix /-ot/ before which no theme sign is used. The corresponding Imperative forms have /-oc/.

- (45) a. él-áp-əm-ot  
 thus-look-TA-UNSPEC/3(3)  
 'he who is looked at'
- b. yáh-à-n      náci míl-oc      máni-m.  
 tell-DIR-2 go give-UNSPEC/3(3) (3)-money-POSS  
 'Tell (sg.) him to go and be given his money.'

The theme signs /-i/ 1.OBJ and /-l/ 2.OBJ are used as in Conjunct and Imperative forms where both subject and object are first or second person, but certain forms with third person subjects are also made with these suffixes. The use of these theme signs corresponds to their use in the Independent Order in the examples in (46), but diverges from the pattern of the Independent in (47). (The form of the theme sign in (47b) is also divergent; it is not clear that the suffix complex in this example is synchronically analyzable.)



Some discussion of the inflectional suffixes of the Conjunct order and their phonological properties will be found in 7.2, 8.1.2, and 10.3.



## ABBREVIATIONS

A, an.	animate
ABS, abs.	absentative
AI	Animate Intransitive
AI+O	transitivized AI
AUG	augment (empty morph)
COND	conditional
DA	derivational affix
DIM, dim.	diminutive
DIR	direct
du.	dual
DUBIT, dubit.	dubitative
EMPH	emphatic particle
exc.	exclusive
FUT	future
I, in.	inanimate
II	Inanimate Intransitive
inc.	inclusive
INV	inverse
LOC, loc.	locative
NF	noun final
NOM	nominalizer
OBJ	object
OBV, obv.	obviative
PART	particle
PASS	passive (i.e., unspecified subject)

PEG	peg (empty) morpheme
PERF	perfective
PL, pl.	plural (= non-dual plural in AI and II verbs)
POSS	possessive
PRET	preterite
PROX, prox.	proximate
RECIP	reciprocal
REFLEX	reflexive
SUBJ	Subjunctive
SUBORD	Subordinative
TA	Transitive Animate
TA+O	double object verb
the other(s)	obviative sg./pl.
TI	Transitive Inanimate
UNSPEC	unspecified subject
1	first person; first person singular
2	second person; second person singular
3	third person; third person singular
11	first person plural; first person plural exclusive
12	first person plural inclusive
22	second person plural
33	third person plural

3PASS

unspecified subject form

with third person

object

2/3 etc.

second person subject with

third person object

(and similarly for

other combinations)

-- Notes --

1. Sherwood (1983b) postulates eleven suffix positions for verbs, but several of these are filled by "morpheme partials" with dubious synchronic status.

2. Most of these observations about gender assignment are due to Robert M. Leavitt.

3. We might in fact postulate phonetically null inanimate subjects for such verbs. In some Algonquian languages (notably in Cree), verbs of this type may be used with inflection for an obviative subject. Since the conditions which govern obviative inflection in these cases appear to parallel those which determine when overt obviative subjects are possible, we can presumably account for the distribution of obviative forms of these verbs by postulating null subjects for them which participate in the system of obviation just like overt noun phrases. I have not encountered such examples in Passamaquoddy, however, where obviation is only rarely indicated for inanimate subjects in verbal inflection.

4. In Bloomfield's terminology, the element -hta- in (13c,d), underlying /-ihte-/, might be classified as a "pre-final," that is as part of a complex final, rather than as a medial, since it is used only with a few finals and is not related to any noun or noun-forming suffix.

5. The underlying forms of maks n- and -aksən may be /maks n/ and /-aksən/. See the discussion of these elements at the end of 6.2.

6. In the meaning 'tree,' épa's has been replaced by stáhkwan at Pleasant Point. At Indian Township, stáhkwan is 'fir.'

7. Nouns which refer to semantically animate beings do not have singular locative forms, but nonetheless have plural locatives: \*skitape-k is out, but we do find skítápewí-hko-k 'among men.'

8. Verb forms with similar repetition of agreement markers are also attested, but the facts are not clear.

9. Sherwood (1983b:135-136) also reports an Unchanged Indicative Mode in Maliseet, but I have found no clear examples of the use of such a mode in Passamaquoddy.

10. Apparently it is possible, although less natural, to use Independent Indicative forms in both clauses in cases of this kind, but the resulting sentence would be making two independent assertions rather than providing a single description: "He's short and he's fat" rather than "He's short and fat."

11. The use of a dual form with a singular noun as subject apparently implies that the subject is accompanied by another individual who is closely connected with him.

## Chapter 3

### Phonetics and Orthography

This chapter introduces the surface phonemes of Passamaquoddy and describes their distribution. If the analyses offered in the remainder of this work are correct, then the underlying or systematic phonemic inventory of the language is essentially the same as this surface inventory, except that certain marginal distinctions of length (in vowels) and voicing (in consonants) are introduced in the course of derivations. Because the same rules introduce distinctive length in some vowels and non-distinctive length in others, no point in the derivation of the surface forms of Passamaquoddy words has the properties of the classical phonemic level.

Section 1 presents the phonemes of Passamaquoddy and their major allophones. For the most part, the phonemic analysis which I propose agrees with those which have been assumed in other recent work on Maliseet and Passamaquoddy, but two areas of controversy require special attention.

In his early work on Maliseet, Teeter (1967, 1971) proposed an analysis of preaspirated stops as unit phonemes and did not distinguish between preaspirated consonants and geminate clusters. Similar analyses have been adopted by Warne (1977a,b) and Szabo (1981). The contrast between preaspirated and geminate

consonants was demonstrated for Maliseet in Teeter and LeSourd (1983). Similar evidence for Passamaquoddy is presented in section 2. An analysis of preaspirated consonants as clusters with prior member h is also motivated in this section.

The question of vowel length is taken up in section 3. Szabo (1972a, 1972b, 1979, 1981) has presented an extensive body of data on the distribution of short and long vowels in Maliseet, which he regards as phonemically distinct. The long vowels of Passamaquoddy are not as salient as those of Maliseet, since they are generally not as long, but their distribution appears to be similar in most respects.

Teeter and LeSourd (1983) argued that vowel length is entirely predictable from context, once accentual differences and the distinction between preaspirated and geminate consonants are taken into account. Sherwood (1983b:63) has since noted, however, that there is a restricted contrast between [u<sup>v</sup>] and [u<sup>v</sup>·] which was not accounted for in our study.<sup>1</sup>

This contrast is found only before w in open penultimate syllables which are stressed or followed by a stressed final syllable. Since /ə/ always remains short in these environments, while other vowels are usually lengthened here, Sherwood proposed that the phonemic distinction in these cases is one of vowel quality rather than length: he writes ə and ɔ for [u<sup>v</sup>] and [u<sup>v</sup>·] before w. He also accounts for the fact that [i] does not undergo lengthening before y by analyzing [i] as ə in this environment.

I will argue on phonological grounds that these proposals of Sherwood's cannot be maintained. I conclude instead that

Maliseet-Passamaquoddy [u<sup>v</sup>] and [u<sup>v</sup>.] before w are in fact o and o., contrasting only in length, and that [i] before y is i. The observed restrictions on lengthening in ow and iy reflect a formulation of the lengthening rules which makes them inapplicable in certain structures in which an element of the segmental tier is linked to more than one position on the CV or timing tier. The same constraint on lengthening may also result in marginal contrasts between short and long vowels before hV.

The remainder of this chapter describes the surface distribution of the phonemes (section 4) and introduces the accentual system of Passamaquoddy (section 5).

### 3.1 Phonemes and allophones

The phonemic inventory of Passamaquoddy includes five syllabic elements and twelve non-syllabics:

#### (1) Syllabic phonemes

i	o
e	a

#### (2) Non-syllabic phonemes

p	t	c	k	kw
	s			h
m	n			
	l			
w	y			

Two additional non-syllabics, ŋ and r, have a marginal status. Still other phonemes, syllabic and non-syllabic, would probably

have to be recognized in a full account of borrowings. A morphological condition which governs voicing in obstruents after word-initial n is discussed below and in 5.3.3. The restricted length contrasts in vowels which were noted above are treated separately in section 3 of this chapter.

Several examples of vowel contrasts are given in (3). The major non-syllabic phonemes are shown in initial position in (4).

(3) áhpit 'he keeps on sitting'<sup>2</sup>  
 éhpit 'woman'  
 íhpit 'where he usually sits'

yàt 'that (an., distant)'

yèt 'that (in., distant)'

yòt 'this (in.), here'

máttahàt 'if he beats the other'

máttihít 'if he beats me'

máttohòt 'if he is beaten'

máttahàt 'if you (sg.) beat him'

mésənəmánpən 'when I got it'

mésənəmánp n 'when you (sg.) got it'

wèt 'intestinal worm'

wàt 'this (an.); his belly'

nít 'that (in.), there, then'

nàt 'that(an.); my belly'



- (4) pàht 'blood clot'  
 tàp 'bow (weapon)'  
 cáls 'grasshopper'  
 kát 'leg (including the foot)'  
 kwákwsəss 'fox'  
 sàht 'blueberry'  
 hàw 'O.K., go ahead'  
 máhkwan 'maple syrup, maple sugar'  
 nàkskw 'young woman'  
 lap 'look (sg.) there!'  
 wawən 'egg'  
 yàkw 'he, they say; it is said'

i is a high, front, unrounded vowel, varying between [i] and [I]. It has its highest and tensest realizations before y, is often quite lax before clusters other than hC or the combinations yy and yw, and is often somewhat centralized before w.

e is a non-high front unrounded vowel. In most environments it is a lax mid vowel [ɛ], but it is [e] before y and is usually [æ] before hC other than hy, hh. (Because vowels are generally long before hC, this low allophone appears only long.) Before l and m and when lengthened at the end of a word, e is often intermediate in height between [ɛ] and [æ].

a is a central vowel, unrounded except before w, and varies in height from mid to high, frequently approaching [ʌ] word-initially and before hC (which is essentially always hkw after a). Before w, a is often rounded to [u<sup>v</sup>]. It is often quite short (except perhaps before hC), and under conditions which have

not been fully determined it may be omitted altogether. In Chapter 4 I draw a distinction between "stressable" and "unstressable" vowels: the former are available to the rules of stress assignment (although they do not necessarily receive stress), while the latter are invisible to the stress rules and thus do not figure into the syllable counts which determine stress placement. In 4.5 I suggest that phonetic reduction or deletion is characteristic of unstressable ə and is a function of syllable timing, which is mediated by the metrical grid. As a rule, I transcribe ə wherever there is a potential for the pronunciation of this vowel. In certain environments, however, notably after hC or ss and between non-syllabic sonorants, unstressable ə is omitted more often than not, except in slow or deliberate speech.<sup>3</sup> Tautosyllabic sequences of ə and a sonorant and certain sequences of the form ə-sonorant-ə are typically realized as a syllabic version of the sonorant.

o is a non-low back round vowel. It is generally intermediate in height between [o] and [u], but is probably best interpreted as a phonologically high vowel, since various occurrences of o are the result of the assimilation of /ə/ to /w/ or of the contraction of /w / (see 3.3.3 below and 5.3.4). o is relatively tense before w and before hC; but it is generally fairly high before w, while variants as low as [o] are sometimes heard before hC, especially from older speakers. Before clusters other than hC or the combinations ww and wy it is frequently a lax [U].

o and ə do not appear to contrast before w, although we will see in section 3 that the distinction between o and o<sup>•</sup> in this

environment frequently reflects an underlying distinction between /ə/ and /o/. While unstressable ə varies between [ɨ<sup>v</sup>] and [u<sup>v</sup>] before w, the phonetic reflexes of stressable /ə/ are fairly consistently rounded in this context. Thus there appears to be no phonetic basis for a distinction between stressable ə and ɔ before w, and I have chosen to transcribe all occurrences of stressable [u<sup>v</sup>] as ɔ. In section 3 I offer a phonological justification for this decision.

a is usually a low back vowel, but it varies considerably in height. Relatively low variants are generally heard before hC, but in other environments variants approaching [ʌ] are common. After labials a is a weakly rounded [ɔ]. It is quite lax in all environments.

For the most part, the non-syllabic phonemes have the points of articulation which the orthography suggests, except that ç is an alveopalatal affricate (i.e. ç). The coronal consonants t, n, and l, are alveolar, but s is an apico-dental spirant. The velar stops k and kw have the same primary point of articulation, but kw is pronounced with a labial release. h is a glottal fricative or a voiceless glide in most positions, but is sometimes phonetically realized only through its effects on adjacent segments, as discussed below.

ç and kw are shown to be unit phonemes by the fact that they have tense, lax, voiced, and aspirated allophones on the same pattern as other single obstruents, as we will see below. They appear in clusters in essentially the same positions as t and k (examples in section 4) and pattern like single segments with respect to the conditions which determine the distribution of

stressable and unstressable vowels. We find long vowels before c and kw under appropriate accentual conditions, whereas only short vowels appear before clusters other than hC: nmícin [nmi·ʃin] 'I eat it,' míkwəl [mi·gwəl] 'he is a crybaby,' but mítso [mIt·suʷ] 'he eats.'

The unit phoneme kw is distinct from a sequence of k plus w: the k of k-wík (2-dwell) 'you (sg.) dwell' is tense, while the kw of kwín 'really' is lax. Little ambiguity is introduced, however, if we do not distinguish between the sequence and the segment in our orthography, since the sequence kw occurs only word-initially where the second person prefix k- is added before w. Thus for typographical convenience I write the unit phoneme kw without raised w.

The aspiration of p, t, k, and kw in preconsonantal and word-final position and the spirantization of k and kw between vowels which Sherwood (1983b:58-59) has noted in Tobique Maliseet are not found in Passamaquoddy or in Woodstock Maliseet.

All of the non-syllabic segments except h are long between a vowel and another non-syllabic, and word-final s is long after a non-syllabic. Otherwise the non-syllabics are short, except that geminate clusters are realized as long versions of the corresponding single segments. This length is phonetically realized in the stop component of geminate or preconsonantal c or kw.

The obstruent phonemes are p, t, c, k, kw, and s. Geminate obstruents are tense, and single obstruents are tense before another non-syllabic and following h, s, or any of the non-syllabic sonorants. s is also tense after any non-syllabic

segment. Elsewhere the obstruents are usually lax, and p, t, k, and kw are partially or fully voiced between vowels for most speakers. (Some speakers voice c and s intervocalically as well.) The labial component of kw is voiceless before a voiceless segment or a pause, but voiced before a voiced segment.

After the n of the first person prefix n(t)-, any single obstruent (including c and kw) is fully voiced for all speakers: n-cals-m [nʃal·sm] (1-grasshopper-POSS) 'my grasshopper.' (The initial obstruent of a cluster in this environment is completely voiceless or only partially voiced: n-sp-əp [nspɫ<sup>v</sup>b] (1-above-sit) 'I sit up high.'). Since the n of the prefix is frequently omitted, except in careful speech, the voicing which it triggers is often its only phonetic reflex. Obstruents are voiceless after word-initial n from other sources, so that voicing has a marginally distinctive status in these consonants, although it is not indicated in the orthography used here. See 5.3.3 for examples of contrastive voicing and a discussion of the phonology of the first person prefix.

h is pronounced with glottal friction when it precedes a vowel, but this friction is frequently omitted where h follows a vowel before another non-syllabic. In this position, h is often realized as a voiceless continuation of the preceding vowel, but it may instead be reflected by the pronunciation of this vowel with creaky voice or only by the relatively greater length which is characteristic of vowels before hC.

Word-initial clusters of h and an obstruent have special phonetic properties. (Initial clusters of h and a sonorant do not occur.) Utterance-initially, h is realized as aspiration of

a following p, t, c, k, or kw, but is reflected only by the phonetic tenseness of a following s. When h in word-initial hC is syllabified with a preceding vowel, it has the usual range of phonetic realizations for h in VhC, but leftward syllabification of h across a word boundary appears to be optional. When it is not carried out, h has the same phonetic realization here as in utterance-initial hC. When h in word-initial hC follows a word ending in a non-syllabic, it can apparently either be deleted (the usual treatment of underlying /h/ in clusters of the form /ChC/ which arise in the course of derivations; see 6.4.1) or be realized again as aspiration or tenseness of the following consonant. The phonology of word-initial hC is considered in detail in 5.3.

Word-initial clusters of the form Ch are uncommon. In n-hésis (1-older.brother) 'my older brother,' where n is the first person prefix, h is pronounced with glottal friction. In khákən 'door,' h is realized as a strong aspiration of the preceding k, distinct from the relatively weak aspiration of k heard in the utterance-initial pronunciation of h-káhákən (3-door) 'his door.' In the few attested clusters of the form CCh, h is sometimes phonetically realized as aspiration of the preceding consonant, sometimes as [h]. See 4.5.5 for an analysis of this variation in terms of differences in syllabification.

m and n appear to be much the same in Passamaquoddy as in English,<sup>4</sup> but l is velarized in all positions and Passamaquoddy w is less rounded than English w.

Some speakers usually have a velar nasal ŋ where others have n before k or kw within a morpheme (always after e or a in native

words), but all speakers have n before a velar consonant across a morpheme boundary: ápéŋk-e (pay-AI-(3)) 'he pays,' sáŋkew-po (calm-sit-(3)) 'he sits still,' áŋkw-ətkóho (further(?)-jump-(3)) 'he jumps from place to place'; but móselèn-k 'Moose Island (loc.),' pán-kamík-e (open-land-II-(3)) 'there is a clearing.' The sequence əŋ is often realized only as a nasalized a: áŋkwəc [əkwə<sup>v</sup>ʃ] 'sometimes.' Even speakers who consistently have ŋk in other morphemes have nk in -anko 'teen': hs-ánko 'thirteen,' nán-ánko 'fifteen.' On the other hand, all speakers use ŋ in borrowings from English: síŋk-ək (sink-LOC) 'in the sink,' k-káti mihtíŋ-ə wí-pa? 'are you (du.) going to have a meeting?'

French and English r have been replaced by l in older borrowings: téhkəleps 'pancake' (from des crêpes), pálcísəl 'pants' (from britches), lélotəwt 'railroad' (from railroad plus əwt 'road, path'). This replacement is still commonly made as borrowing from English continues (álanəcis 'orange (fruit)'), but English r is often retained in nonce borrowings (paráhs 'brush') and some forms with r have undoubtedly become established words (síkarétsək 'cigarettes'). One "slang" coinage containing r was current at Indian Township when I was working there in 1978: kənatiri [gndiri] 'no.'

### 3.2 Plain, preaspirated, and long consonants

Phonetically plain, preaspirated, and long obstruents contrast both in Maliseet and in Passamaquoddy. Plain, preaspirated, and long sonorant consonants also contrast in Passamaquoddy and in some Maliseet dialects, but the preaspirated

sonorants have merged with the long sonorants in the Maliseet of Woodstock, N.B. For the sequences hy, yy, and w, see section 4.

Teeter (1967, 1971) suggested that preaspirated obstruents should be analyzed as single segments and set up a series of phonemes to accommodate them, which he regarded as distinguished from the plain obstruents principally by the feature of tenseness. He analyzed phonetically long obstruents as non-contrastive variants of the tense obstruents and did not distinguish between length and preaspiration in sonorant consonants since he was working primarily with Woodstock material.

Warne (1977a,b) and Szabó (1981) take essentially the same position as Teeter (1971) with respect to length and preaspiration. Sherwood (1983b), on the other hand, assumes that preaspirated consonants are clusters with prior member h and that long consonants are geminate clusters. I will argue here that the latter position is correct.

The contrast of plain, preaspirated, and long obstruents was reported for Maliseet in Teeter and LeSourd (1983). Passamaquoddy examples are given in (5).

- (5) mácépo 'he starts to sit up (said of children)'  
mácéhpo 'he starts to eat'  
éwéppo 'he sits up, he is located at a height'
- skítáhkwem 'outer wood'  
píhtákme 'it is a long lake'  
kíttákən 'file (for working wood or metal)'



wíciyémal 'he goes around with the other'  
píhciyétol 'they (in.) go far'  
wíccicképiyil 'bandages'

póspékihkèk 'when the grass was wet'  
ntótenèhk 'I go shopping in town'  
wálákwèkk 'they (du.) are already in bed'

píkwənewátpe 'he has bushy hair'  
wíhkwənal 'he takes hold of the other'  
wíkwəat 'the tide goes out'

ntásitémal 'he answers the other'  
htásihpílal 'he gives the other medicine'  
ássihkáwe 'he meets someone'

Passamaquoddy also distinguishes between plain, preaspirated, and long sonorant consonants, although hn occurs only in a few stems. Examples are given in (6).

(6) máwəman 'he calls the others together  
(Subordinative)'

étəlihtəmən 'when I was hitting it'  
təmmət 'when he bit the other in two'

má te wəhkaŋò 'no one uses it anymore'  
mənahnòk 'Grand Manan Island (loc.)'  
knícannòk 'our (inc.) children (abs.)'

mácélan 'it starts to rain'  
mácéhlal 'he moves the other'

éllátak 'the way he breathes'

The comparisons in (7) and (8) reveal the merger of hm, hn, and hl with mm, nn, and ll in Woodstock Maliseet.<sup>5</sup>

(7) a. Pass. htámmal: W.Mal. wtámmal

'he bites the other in two'

b. Pass. nícánnok: W.Mal. nícánnok

'our (exc.) children'

c. Pass. kmíllan: W.Mal. kmíllan

'I give it to you (sg.)'

(8) a. Pass. hkísánóhman: W.Mal. wkísánómmán

'he bought it'

b. Pass. náhnákan: W.Mal. nánnákan

'it is light in weight'

c. Pass. hpásséhlal: W.Mal. wpásséllal

'he skins the other'

Many of the preaspirated consonants of Maliseet-Passamaquoddy reflect Proto-Algonquian clusters, while others have resulted from syncope in pre-Maliseet-Passamaquoddy \*hVC (Warne 1977a). For example, PA \*a'skikwa 'seal' (Siebert 1967:19) gives Passamaquoddy áhkikw, while PA \*a?lapyá 'net' (Siebert 1967:19) gives Passamaquoddy áhp, in which h is the expected reflex of \*?l. Thus the hypothesis that preaspirated obstruents are unit phonemes in Maliseet-Passamaquoddy requires us to suppose that there has been a reanalysis of earlier hC clusters as single segments. There are several reasons to believe that no such reanalysis has taken place.

First, clusters of h and an obstruent are expected on distributional grounds. We will see in section 4 that two-place clusters in which the second segment is an obstruent are quite free in Maliseet-Passamaquoddy. If we analyze preaspirated obstruents as single segments, we will have to postulate an otherwise unmotivated constraint to rule out h-obstruent clusters.

Second, the phonetic tenseness of preaspirated obstruents is what we expect of obstruents in clusters in which the first member is a continuant. For example, although k is lax (and voiced) in nsókiwán [nʒiːʷgiːwiːn] 'my urine,' it is tense in skiwán [skiːwiːn] 'urine,' where it follows g as a result of syncope. Thus it is not necessary to set up a separate series of tense obstruents in order to account for the distribution of phonetically tense and lax segments.

Finally, it is clear that most occurrences of hm are synchronically derived by syncope: compare Passamaquoddy íkatáham 'he yawns,' íkatéhmok 'they (du.) yawr.' (For an analysis of syncope between /h/ and /m/, see 5.6.) Thus hm, at least, is clearly a phonological cluster. Presumably it is also a phonemic cluster. But the phonetics of preaspiration are much the same for hm as for other preaspirated consonants. Thus it seems best to regard all of the preaspirated consonants as clusters. (Sherwood derives a variety of preaspirated consonants in addition to hm from underlying /hVC/, but it is difficult to motivate synchronic syncope in most such cases. See 4.6 for discussion of one class of examples which bear on this question.)

We will see in Chapter 4 that most clusters of the form hC pattern like single segments within the system of conditions that determines the distribution of stressable and unstressable vowels, although hl patterns like a cluster in this respect. In 4.5.4, however, I suggest an explanation for this fact in terms of the principles which govern syllabification. If this account is accepted, then the conditions which determine stressability do not provide evidence for an analysis of preaspirated consonants as unit phonemes.

The analysis of long consonants as geminate clusters is easily motivated, since they frequently arise at morpheme boundaries where two plain consonants are brought into sequence: compare éwép-po (up-sit-(3)) 'he sits up, he is located at a height' with éwép-te (up-located-(3)) 'it is located at a height,' mét-témo (finish-cry-(3)) 'he stops crying' with tál-ətémo (ongoing-cry-(3)) 'he is crying,' h-kís-s-a-l (3-past-cut-DIR-3.OBV) 'he cut the other' with kís-ətémo (past-cry-(3)) 'he cried.' A detailed discussion of the phonology of geminate consonants is given in 5.7.

### 3.3 Vowel length

Since the phonemic status of vowel length in Maliseet has been a subject of controversy, I will consider the distribution of short and long vowels in both Maliseet and Passamaquoddy in some detail in this section. I will argue that vowel length is phonologically predictable in both dialects, but that a condition on the rules by which long vowels are derived results in the

introduction of certain restricted length contrasts in surface forms.

Short and long vowels are distributed along similar lines in the two dialects, although there are a few significant points on which they differ. Sherwood's description of the phonetics of Tobique Maliseet suggests that this variety of the language may differ somewhat from those with which I am more familiar with respect to length in both vowels and consonants. The fact that Karl Teeter and I have found substantial agreement on vowel length between Woodstock Maliseet and the dialect reported by Szabo suggests, however, that the account of the distribution of vowel length given here should hold for a wide range of Maliseet speakers.

To facilitate discussion of the determinants of vowel length, I will distinguish between short and long vowels throughout this section by marking the long vowels with a raised dot. Elsewhere in this work, vowel length is generally indicated only to distinguish o and o<sup>•</sup> before w, where they contrast.

### 3.3.1 Vowel length in Maliseet

All of the Maliseet vowels except a occur both short and long.<sup>6</sup> While there is a good deal of variation in the phonetic length of vowels in all contexts, it is clear that short vowels are the norm in some environments and long vowels in others.

In the speech of my principal Maliseet consultant, Peter Lewis Paul of Woodstock, N.B., long vowels are frequently

rearticulated and long i and o may be interrupted by a voiced h-like glide: nwísakè.ləm [n̥wizəgɛ̀ɛlm] 'I laughed hard,' ci.kən [ʃi.gn̥] ~ [ʃiɦʲign̥] 'apple,' əpó.nəl [əbuˈuːn̥l̥] ~ [əbuɦʲuˈuːn̥l̥] 'beds.' Similar pronunciations are probably the motivation for the alternate spellings which Szabo lists for wí.k 'his house' and htó.l 'his boat': for the former he gives both "wiyik" and "wiik," for the latter both "'towol" and "'tool" (1981:250, 230). Haas (1936) noted rearticulation of long vowels in both Penobscot and Passamaquoddy in the speech of Andrew Dana of Indian Island, ME. I have not encountered this type of pronunciation in contemporary Passamaquoddy, however.

If we assume that the short vowels are basic, we can account for the distribution of the long variants of i, e, o, and a by postulating rules which lengthen these vowels in several specific contexts, most of them involving accent. (Any attempt to account for the distribution of short and long vowels by means of shortening rules instead of lengthening rules would clearly be much more cumbersome, since there is no simple way to state the complement of the class of environments in which long vowels are found.)

First, i, e, o, and a are lengthened before any cluster of the form hC (an environment from which ə is generally excluded). Sherwood (1983b:64) suggests that lengthening in this environment is limited to stressed vowels in Tobique Maliseet, but I hear long vowels before hC in all positions in Woodstock:<sup>7</sup>

- (9) sákəmə́·hk 'where the chief is'  
 é·hpit 'woman'  
 pí·htiná·hk<sup>é</sup>wem 'arm'  
 wéno·hcəwàtəwe he speaks English'  
 káskwé·hso·hs 'old woman'  
 skát wí·hk<sup>é</sup>wé·hto·hti·hk<sup>é</sup>w 'if they do not  
 pick it up'

Before other clusters, including geminates, we find only short vowels:

- (10) ní·hkanátpa 'head (of an organization)'  
 mácéphal 'he takes the other away'  
 kətá·ma nó<sup>é</sup>tak<sup>é</sup>wsiw 'he is not heard from'
- (11) sákəmə́kk 'chiefs (abs.)'  
 étalí ksak<sup>é</sup>kassit 'where he is going across'  
 panékwé<sup>é</sup>ssó 'he comes down'

For Peter Paul, e is occasionally [ɛ] rather than [æ] before hs: tək<sup>é</sup>wəhs, 'twin,' má·htək<sup>é</sup>wəhs 'rabbit,' má·htək<sup>é</sup>wəhsəwəl 'rabbit (obv.).' But Szabó (1981:217, 109) gives "təkweehs" and "maahtəkweehs," suggesting that his consultants have long e before hs in these words.

The geminate sonorants of Woodstock are preceded by short vowels even when they correspond to hC in other dialects: wcánéllal 'he stops the other (motion),' wkísənòmman 'he bought it,' nánnák n 'it is light in weight'; cf. Passamaquoddy hcáné·hlal, hkísənó·hm n, ná·hná·k n. Szabó generally reports short vowels before "hl" but long vowels before "hm" in such

cases: "'cənehlal" 'he stops him,' "mənoohmən" 'he buys it' (1981:43, 124). Perhaps, then, hl has merged with ll for Szabo's consultants, but hm and mm have remained distinct. (I have found no examples of "hn" in Szabo's work.)

Vowels other than ə are also typically lengthened in open penultimate syllables if either of two accentual conditions is met: (i) the penultimate syllable is itself stressed, (ii) the word-final syllable is stressed. Stressed penultimate syllables may be either high-pitched or low-pitched (indicated with the acute accent or the grave accent, respectively). In all cases relevant to (ii), the word-final syllable bears the grave accent. (Such syllables are low-pitched when followed by further material but pronounced with rising intonation before a pause. See section 5 for further discussion.) Three types of words are systematic exceptions to both generalizations.

Case (i) is illustrated by the forms in (12). Compare táke 'he hits,' where ə remains short in a stressed open penult.

- (12) ná.tá.me 'he goes fishing'  
 tá.llá.təm 'he is breathing'  
 lé.yo 'it happens thus'  
 é.hpí.cik 'women'  
 sà.kəm 'chief, tribal governor'  
 wí.sahò.la 'he is taken by boat hurriedly'  
 nmíl.hə.mà.pən 'we (du. inc.) do various things (at an event)'



Case (ii) is illustrated in (13). These forms may be compared with ato·hk 'deer' and nekamaw 'they (an.),' where a again remains short.

- (13) ka·ta·ma ná·ta·mêw 'he does not go fishing'  
 lo·hke·wîn 'worker'  
 mó·wi·nêw 'bearskin'  
 kó·sa·mí ma·nîm 'you (sg.) have too much money'

Forms like ski·táp 'man,' ski·cîn 'Indian,' and sa·ki·ht 'look (sg.) at it!' fall under both generalizations, since both the penult and the ultima are stressed in these words.

The systematic exceptions to (i) and (ii) involve vowels before glides: i before y, o before w, and the first vowel in certain sequences of the form VhV. In the first case, lengthening is consistently blocked, so that long i does not occur before y:

- (14) pa·mi·ye 'he travels (by water)'  
 ə·lə·mi·ye 'he goes away'  
 wti·yal 'he tells the other'  
 wti·ya 'he tells the others'

Many occurrences of o before w also fail to undergo lengthening, but others do lengthen, resulting in the marginal contrast between o and o· in this environment which was noted above:

- (15) méskówat 'he who finds the other'  
 ápátkawátówak 'they (du.) return'  
 pócakwəssímsowà 'he (abs.) has drowned himself'  
 but: mó·wín 'bear'

The first vowel in VhV is generally exempt from lengthening if it is the same as the second, but lengthening proceeds regularly if the two vowels are different:

- (16) kséhe 'he enters'  
 nkəssáha 'I enter'  
 yáhàn 'tell (sg.) him!'  
 but: mácé·həm 'he swims away'

Note also á·hà 'yes,' apparently an exceptional form.

I will return to these conditions in 3.3.3, where I will argue that most of the restrictions on lengthening can be explained if the lengthening rules are formulated so that they are not applicable in the kind of multiply linked structures which result from assimilation by feature spreading.

Lengthening in penultimate syllables is frequently neglected in certain common words with special grammatical functions, especially when they are used in connected discourse rather than cited in isolation: kátá·ma ~ kátáma 'not,' ná·ka ~ náka 'and'; cf. ná·kà 'that (an., abs.),' in which the first a seems to be more consistently long.

Where the vowel of a stressed open penult remains short, a vowel other than ə is lengthened in an immediately preceding open syllable:

- (17) pé·ciye 'he arrives'  
pəné·kwiye 'it falls down'  
péci nátsa·kiyal 'he comes to see the other'  
pəmáwsówi·nówak 'people'  
má·céhe 'he leaves'  
óci má·cáhan 'he goes away (Subordinative)'

Some Maliseet speakers appear to have a more general lengthening rule, so that they have long vowels in open antepenultimate syllables in a broader range of cases in which the penult is stressed.

There seems to be some hesitation or uncertainty about penultimate lengthening before hV in those cases where it is permitted, but apparently antepenultimate lengthening is carried out regularly in such cases when penultimate lengthening is blocked: nmáce·həm ~ nmá·céhəm 'I swim away.'

The vowel of a monosyllabic word is lengthened if it bears the acute accent and is followed by at most one consonant: wí·k 'his house,' hkwá·t 'his foot,' wtó·l 'his canoe'; compare wèn 'someone, who,' màn 'money,' wtòl 'his canoe (abs.).' I have no example of a Maliseet monosyllable where the vowel bears the acute accent and is followed by a cluster other than hC, but Szabó (1981:254) gives "witkw" 'eyebrow' with short i; cf. Passamaquoddy witkw 'eyebrow, his eyebrow.' I know of no monosyllabic words with the vowel ə where this vowel bears the acute accent.

Word-final vowels are occasionally lengthened, especially before a pause: ksá·te 'it (weather) is hot,' náka 'and...'

It should also be noted that iy and ow are phonetically [i•] and [u•] before h, w, or y: ntíywa [ndi•wɔ] 'I have him.' The sequence iy is distinguished from lengthened i before w by the higher and tenser pronunciation of the former.

Perhaps other environments in which lengthening is more or less likely could be identified, but those given here appear to account for the vast majority of the long vowels noted in Szabo's works. Some of those which remain may be the result of emphatic lengthening or may simply reflect the variability of phonetic length. It is also possible that his recordings sometimes reflect his sensitivity to finer distinctions of length than those which I have considered here. A probable example of the latter type is provided by the forms which Szabo (1981:105, 32) lists as "lapotihiike" 'he looks through a telescope, binoculars, etc.' and "alapotihiike" 'he looks around with binoculars.' The stress rules developed in Chapter 4, which appear for the most part to be appropriate for Maliseet as well as for Passamaquoddy, will produce the stress patterns for these words shown in (18).

- (18) a.    2    3            1  
           l a p o t i h i • k e
- b. 2            2            1  
           a l a p o t i h i • k e

On the basis of the generalizations about vowel length given above, we will predict long vowels only in the penultimate syllables of these forms. Since it seems likely, however, that greater stress is generally accompanied by greater phonetic

length in open syllables in all positions, it seems reasonable to suppose that the distinction which Szabo makes between "o" and "oo" in these examples reflects a difference in length between o bearing tertiary stress in (18a) and o bearing secondary stress in (18b).

### 3.3.2 Vowel length in Passamaquoddy

Vowels are lengthened in Passamaquoddy in several of the same environments as in Maliseet, but not in all of them. Moreover, the long vowels of Passamaquoddy are generally not as long as those of Maliseet, so that vowel length is less salient overall in the Passamaquoddy dialect.

Lengthening of i, e, o, and a before hC is illustrated in (19). While the sequence hkw occurs in several verb endings, I am not certain of the length of    in these cases.

- (19) e'hpit 'woman'  
 hpi'htina'hwé'mə] 'his arms'  
 kəskwé'hso'hs 'old woman'  
 nkisi'hpí'hpən 'I ate'  
 wíco'hké'mal 'he helps the other'

As in Maliseet, vowels other than a are lengthened in an open penultimate syllable if (i) this syllable is itself stressed or (ii) the word-final syllable is stressed. Despite a number of accentual differences between the dialects, it is still the case in Passamaquoddy that penultimate syllables which undergo

lengthening by (i) may bear either the acute or the grave accent, while the word-final syllable always bears the grave accent in words which undergo penultimate lengthening by (ii).

The two generalizations are illustrated in (20) and (21). Schwa remains short in táke 'he hits,' ətó·hk 'deer,' and nékamàw 'they,' as in Maliseet.

- (20) ná<sup>á</sup>ta·me 'he goes fishing'  
 élé·yik 'the way it happened'  
 nté·hpí·tem 'my woman, my wife'  
 ná<sup>á</sup>táke·hkí·mâ 'he goes to school'  
 ntákwakwíptinà·pàn 'we (du. exc.) have dirty hands'

- (21) má àpc náta·mèw 'he will not go fishing again'  
 nóma·nim 'I have money'  
 máni·míw 'he has money'

Once again, words like skí·táp 'man' and skí·cìn 'Indian' fall under both generalizations, as does sá·kam 'chief, tribal governor' as well, since both syllables of this word are stressed in Passamaquoddy, rather than just the first as in Maliseet.

As before, we find systematic exceptions to penultimate lengthening involving i before y, o before w, and the first vowel in VhV when it is the same as the second. A marginal contrast between o and o· before w results from the fact that some occurrences of o do undergo lengthening in this environment.

- (22) á<sup>á</sup>lamiye 'he goes away'  
 ká<sup>á</sup>tawitáwíye 'he wants to fly'  
 htí<sup>á</sup>yal 'he tells the other'

(23) síkte·hpáyoltówək 'they (pl.) are very  
frightened'

pskówá 'he is found'

pamáwsowin 'person'

but: mó·win 'bear'

(24) kséhe 'he enters'

kné·hpihi 'you (sg.) kill me'

yáhan 'tell (sg.) him'

but: ési·hək 'when he watered it'

A few words have irregular reduced forms which may reflect sporadic exceptions to lengthening like those noted above for Maliseet: naka 'and' is frequently [ŋga], while mósa 'don't!' is almost always heard as [m̩za] in the common expression témanò mósa pəl 'just a minute' (literally "later don't first").

The antepenultimate lengthening which is characteristic of Maliseet forms like pé·cíye 'he arrives' apparently does not take place in Passamaquoddy: I hear no special length in the underlined positions in the words in (25).

(25) pé·cíye 'he arrives'

má·cáhan 'he leaves (Subordinative)'

nátsakíyal 'he goes and sees the other'

skicinówək 'Indians'

The lengthening which is typical of Maliseet monosyllables which bear the acute accent is also lacking in Passamaquoddy. Thus we have short vowels in wík 'his house' and kát 'leg (including the foot),' as well as in wèn 'someone, who' and màn

'money.' There does not appear to be any difference in vowel length which corresponds to the difference in accent in pairs like ntól 'my canoe' and ntòl 'my canoe (abs.).'

On the other hand, word-final vowels are frequently rather long in Passamaquoddy: até.te 'it (abs.) was there,' má te 'not' (the latter with the mild emphatic te, which is usually treated as an enclitic after another particle). As before, the sequences iy and ow are phonetically [i<sup>•</sup>] and [u<sup>•</sup>] before a non-syllabic: htíywal [t<sup>h</sup>i.wɔl] 'he has the other,' kówwà [g<sup>•</sup>u.wɔ] 'he (abs.) is asleep,' ckówye [ɔku<sup>•</sup>.yɛ] 'he comes toward here.' Vowels are frequently lengthened for emphasis in positions in which length would not otherwise be found, especially in initial syllables: é.lápəmit 'he looked at me.'

### 3.3.3 Vowel length and assimilation

Three classes of systematic exceptions to lengthening in penultimate syllables were identified above: i is never lengthened before y; many occurrences of o before w do not undergo lengthening, although some do; and the first vowel in VhV is not usually subject to lengthening if it matches the second. These exceptions to lengthening appear to reflect a formulation of the lengthening rules which makes them inapplicable in certain structures in which a single element of the segmental tier is associated with more than one position in the CV skeleton. It may ultimately be possible to provide an explanation for the restrictions in question in terms of a universal constraint on



rule application in multiply linked structures along the lines of those proposed by Hayes (1984, 1986a,b) and by Schein and Steriade (1986) in recent work on the blocking effects of geminates. Neither of these proposals appears to have quite the right properties, however, to account for the facts of lengthening in Maliseet-Passamaquoddy.

Since I have more complete data for Passamaquoddy than for Maliseet, I will discuss only Passamaquoddy examples in this section. It seems likely, however, that the arguments given here could be duplicated straightforwardly with Maliseet material. (Many of the crucial examples may be found in Szabo (1981).)

The occurrences of ow in which lengthening is permitted are those which are derived from underlying /ow/. Thus, for example, the /o/ of the TI final /-hto-/ is subject to penultimate lengthening before the negative suffix /-w-/, and the /o/ of the inverse theme sign /-əko-/ undergoes lengthening before the agreement marker /-wa-/ 33PROX. The examples in (26) and (27) first show these morphemes separately and then in the combinations which permit lengthening in /ow/.

(26) a. námi'-hto-n

(3)-see-TI-3IN

'he sees it'

b. má te ht-ówe·hká'-w-ən

not EMPH 3-use-NEG-3IN

'he does not use it'

c. má te námi'-htó'-w-ən  
 not EMPH (3)-see-TI-NEG-3IN  
 'he does not see it'

(27) a. n-síkté'-hpawəl-əkó-n  
 1-to.death-frighten-INV-33PROX-3.OBV  
 'it really frightens me'

b. ht-íy-á'-wa-l  
 3-tell-DIR-33PROX-3.OBV  
 'they tell the other'

c. h-síkte'-hpawəl-əkó'-wa-l  
 3-to.death-frighten-INV-33PROX-3.OBV  
 'the other really frightens them'

We may also assume that ow ~ o·w represents underlying /ow/ in mówiní-hil (bear-3.OBV) 'bear (obv.)' and mó·win 'bear,' since apart from the length alternation this sequence is invariant. Within the framework of CV phonology, then, we can represent those occurrences of ow in which lengthening is applicable as shown in (28), where o and w are represented as distinct elements of the segmental tier. (I assume, in fact, that o and w have identical representations on the segmental tier, although I will generally maintain an orthographic distinction between them in CV representations simply to make it easier to relate these representations to transcriptions of the corresponding forms. I return to this matter immediately below.)

(28) V C  
 | |  
 o w

Those occurrences of ow in which lengthening is not applicable are derived by rules of assimilation from either of two phonological sources: /əw/ and /oh/. (We will see in 4.6 that some occurrences of /əw/ are derived from /iw/ by the morphologically governed rule of I-Mutation.) If we analyze assimilation as a process of "feature spreading" by which an element of the segmental tier comes to be associated with more than one position on the CV tier, then ow from either of these sources will be represented in surface forms as shown in (29). (Here it is not possible to maintain an orthographic distinction between o and w.)

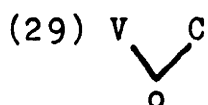

To distinguish the right cases for lengthening, then, it is sufficient to formulate the lengthening rules so that they are applicable to structures like (28) where each element of the segmental tier is independently linked to the CV tier, but not in multiply linked structures like (29).<sup>8</sup>

The failure of lengthening where ow is derived from /əw/ can be seen in appropriate forms of the TA verbs /mæsk-əw-/ 'find' and /nəsət-əw-/ 'understand,' which have surface stems psk-ow- and nəst-ow-, as shown in (30). The rules of syncope and devoicing which give psk- and nəst- for /mæsk-/ and /nəsət-/ in these examples will be discussed in Chapter 5. What is relevant in the present context is the fact that o remains short in all of these examples in environments in which penultimate lengthening is usually applicable.

- (30) a. psk-ow-â  
 find-TA-3PASS  
 'he is found'
- b. má te psk-ow-à-w  
 not EMPH find-TA-3PASS-NEG  
 'he is not found'
- c. n<sup>á</sup>st-ow-a-l  
 (3)-understand-TA-DIR-3.OBV  
 'he understands the other'

The motivation for setting up underlying /əw/ for the TA final which shows up as -ow- in (30) comes from the fact that the same element surfaces as -əw- in forms like (31), and more generally from the fact that the vowel of this final patterns like /ə/ with respect to the conditions which determine when the presence of /ə/ is taken into account by the rules of stress assignment.

- (31) n<sup>ó</sup>t-əw-a-l  
 (3)-hear-TA-DIR-3.OBV  
 'he hears the other'

The underlying identity of -ow- and -əw- is shown by the fact that all of the TA stems in (30) and (31) correspond to TI stems in /-əm-/, and by the fact that they are all subject to a rule which replaces stem-final /-əw-/ with /a/ before certain suffixes (see 7.2 for discussion).

- (32) a. psk-əm-ən  
 find-TI-1-(SUBJ)  
 'if I find it'
- b. nəst-əm-ən  
 (3)-understand-TI-3IN  
 'he understands it'
- c. not-əm-ən  
 (3)-hear-TI-3IN  
 'he hears it'
- (33) a. psk-ə-hc  
 find-TA-3(3)OBV/3PROX  
 'have the other(s) find him!'
- b. nəst-a-kw  
 (1)-understand-TA-INV  
 'he understands me'
- c. not-a-kw  
 (1)-hear-TA-INV  
 'he hears me'

The surface distribution of -ow- and -w- is dictated by the rules which determine when /ə/ counts for stress placement, which will be formulated in Chapter 4. Stressable /ə/ is typically represented by [u<sup>✓</sup>] before w, suggesting that it becomes o in this position. Unstressable /ə/ is only optionally rounded before w, so I will assume that it remains ə in this environment. (Since there are no surface occurrences of unstressable o, however, it would be possible to write o everywhere for the surface realization of /ə/ before w.)

If we suppose that o is phonologically a high vowel, then o and w differ only in syllabicity, not in terms of distinctive features. The change of /w/ to /ow/ can thus be represented as a process by which the features of /ə/ are deleted and the features of /w/ come to spread onto the V position left empty by this deletion, creating a multiply linked structure. Using the notational conventions suggested above, this change can be represented as follows.<sup>9</sup>

(34) Schwa Rounding

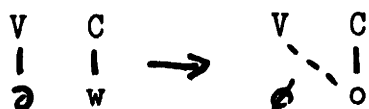

Now in Chapter 4 I will argue that stressable schwas are schwas which are associated with V-slots at the point in derivations when stress is assigned, while unstressable schwas are floating vowels at this point. Unstressable schwas which are not subject to syncope are supplied with V-slots late in derivations by the rule of Schwa Support. Thus if Schwa Rounding is ordered prior to Schwa Support it will have the effect of changing just those schwas which are stressable into o before w.

Because surface ow in nástówal 'he understands the other' is derived from /əw/ by Schwa Rounding, this word has the surface form shown in (35), in which the segment o is linked to two positions on the CV tier. Compare the representation of námi·htó·wən 'he does not see it' prior to the application of the lengthening rules, which is given in (36). Here ow is a sequence on the segmental tier as well as on the CV tier.

(35) C V C C V C V C  
 | | | | V | |  
 n ə s t o a l

(36) C V C V C C V C V C  
 | | | | | | | | | |  
 n ə m i h t o w ə n

It is clear, then, that penultimate lengthening will be blocked as required in nástówal, but will nonetheless be applicable in námí·htó·wə́n, if the lengthening rules are not applicable in multiply linked structures.

Of course, if no occurrences of [u<sup>v</sup>] except those derived from /ə/ failed to undergo lengthening before w, then this analysis of the restrictions on lengthening would be beside the point: we could simply analyze [u<sup>v</sup>] and [u<sup>v</sup>.] as phonemic ə and o, since ə does not undergo penultimate lengthening in any case. This is essentially the position adopted by Sherwood (1983b).

As it happens, though, o also fails to undergo lengthening in ow which is derived from /oh/. This is why o is short in (37a) and (38a). The underlying stems of these verbs are /mənoh-/ TA 'buy' and /nəsəto-h-/ TA 'mention,' as a comparison with the (b) forms reveals. The derivational pattern seen in these examples is one in which TA stems in /-h-/ are matched by TI stems in /-h-əm-/: compare (39a,b). (For the deletion of /ə/ in /həm/, see 5.6.) Examples (37c) and (38c) show that the TA stems for 'buy' and 'mention' do not end in underlying /əw/, since they do not undergo the rule which changes this sequence to /a/. (Instead, an epenthetic /ə/ is added before /-kw/, the word-final allomorph of the inverse theme sign, as discussed in 7.2.)

- (37) a. mánó-w-a-l  
 (3)-buy-TA-DIR-3.OBV  
 'he buys the other'
- b. mánó'-h-m-ən  
 (3)-buy-TI-TI-3IN  
 'he buys it'
- cf. c. n-kís-ənó-w-ək  
 1-past-buy-TA-INV  
 'he bought me'
- (38) a. nástó-w-a-l  
 (3)-mention-TA-DIR-3.OBV  
 'he mentions the other'
- b. nástó'-h-m-ən  
 (3)-mention-TI-TI-3IN  
 'he mentions it'
- c. nástó-w-ək  
 (1)-mention-TA-INV  
 'he mentions me'
- (39) a. h-pát-tá-h-a-l  
 3-accidentally-strike-TA-DIR-3.OBV  
 'he hits the other accidentally'
- b. h-pát-té'-h-m-ən  
 3-accidentally-strike-TI-TI-3IN  
 'he hits it accidentally'

Since there is no motivation for a rule which would change /o/ to /ə/ in the derivations of mánówal 'he buys the other' and



nástówal 'he mentions the other,' it seems clear that these words must have surface representations with ow. Note, however, that nástówal 'he mentions the other' is phonetically identical with nástówal 'he understands the other.' Thus it seems reasonable to assume that [w] is surface ow in the latter as well.

The rule which gives ow for /oh/ in (37) and (38) can again be formulated as a process of assimilation by feature spreading, and might be stated as follows.

(40) H-Assimilation



Sherwood (1983b:35-36) reports that this process applies only before vowels other than /o/ for his Maliseet consultants, and I suspect that the same restriction holds for some Passamaquoddy speakers. Others, however, have apparently generalized the rule so that it applies before any vowel: wéci k'ís-anó-w-ok (from past-buy-TA-1/3(3)) 'why I bought it/them (an.)' (A.H.).

Given the rule of H-Assimilation as formulated in (40), the surface representation of n stowal 'he mentions the other' will be that shown in (41), identical with the surface representation of n stowal 'he understands the other,' given as (35) above.



Prohibiting lengthening in multiply linked structures will again produce the right results.

The failure of lengthening in iy can also be brought under this generalization, but apparently only at the cost of postulating a rule for which there is no independent justification. What is needed is a rule which will turn all occurrences of iy into multiply linked structures, removing all such sequences from the domain of the lengthening rules.

Sherwood's account of H-Assimilation in Maliseet provides a basis for supposing that some occurrences of iy in that dialect are represented as multiply linked structures, since his rule not only changes /h/ to /w/ after /o/ but also turns /h/ into /y/ after /i/ (before vowels other than /i/). This analysis seems plausible for Maliseet, and there are some alternations which attest the former application of a similarly general rule in Passamaquoddy, but there are counterexamples in the contemporary language which suggest that the rule changing /h/ to /y/ has now been morphologized.

An alternation between /h/ and /y/ is found in the abstract TA final /-h-/ ~ /-y-/ and in the AI and II final /-ha-/ ~ /-ya-/ 'go,' as shown in (42)-(44).

(42) a. nípa'-h-a-l

(3)-at.night-TA-DIR-3.OBV

'he makes the other at night'

cf. b. nípa'-hto-n

(3)-at.night-TI-3IN

'he makes it at night'

(43) a. h-kí-sí-y-a-l  
 3-past-TA-DIR-3.OBV  
 'he made the other'

cf. b. h-kí-sí'-hto-n  
 3-past-TI-3IN  
 'he made it'

(44) a. k-ká-ssa-há'-pa  
 2-in-go-22  
 'you (du.) enter'

b. kt-á-li-yá'-pa  
 'you (du.) go there'

Underlying /ihV/ is maintained on the surface, however, in forms like pám-ákámí'-həm (along-snowshoe-AI-(3)) 'he goes along on snowshoes.' (Compare Woodstock Maliseet pám-ákə mí-yəm 'he goes along on snowshoes' and pám-ákəmí-mm-ok 'they (du.) go along on snowshoes,' both presumably reflecting a stem /pám-akəmi-həm-/.) In (45) and (46), /h/ undergoes assimilation to /o/ but surfaces unchanged after /i/ under entirely parallel conditions. (Here compare Woodstock ápci pám-ákəmí-yə-k 'while he goes along on snowshoes.')

(45) a. méno'-h-m-àn  
 buy-TI-TI-1-(PERF)  
 'when I bought it'

b. méno-w-ə-k  
 buy-TI-TI-3AN-(PERF)  
 'when he bought it'

- (46) a. ési<sup>•</sup>-h-m-à<sup>̀</sup>n  
 give-drink-TI-TI-1-(PERF)  
 'when I watered it'
- b. ési<sup>•</sup>-h-ə<sup>̀</sup>-k  
 give.drink-TI-TI-3AN-(PERF)  
 'when he watered it'

Since the change of /h/ to /y/ after /i/ appears to be an idiosyncratic property of certain morphemes in contemporary Passamaquoddy, I will assume that alternations like those in /-h-/ ~ /-y-/ and /-ha-/ ~ /-ya-/ are stated as rules of allomorphy and do not reflect a phonological process of assimilation. It is not obvious that such allomorphy rules would generate multiply linked structures, and I will not explore this possibility here.

In any case, the failure of penultimate lengthening in iy is not tied to the application of particular rules, as is the comparable blocking of lengthening in ow. Lengthening does not affect i before y even in non-derived environments, whereas basic morpheme-internal ow may undergo lengthening: compare tí<sup>•</sup>htiyas 'bluejay' with mó<sup>•</sup>wín 'bear.' Sherwood encodes this restriction by phonemicizing all occurrences of [I] before y in Tobique Maliseet as ə, a move which is possible because ə and i do not contrast in this environment. In order to maintain this position, however, he must postulate a rule which changes underlying /i/ to /ə/ before /y/ (1983b:38): in a word like pé<sup>•</sup>bí<sup>•</sup>-ye (arrive-go-(3)) 'he arrives,' which Sherwood transcribes as "pecəye," the second vowel must be underlying /i/ both because it

causes palatalization of the preceding /t/ in /pet-/ 'arrive' (see 6.6) and because it is followed by /-ya-/ rather than /-ha-/ 'go' (see 8.1.3 for the change of /-ya-/ to /-ye-/ in this form). Since Passamaquoddy (and Woodstock Maliseet) i has its highest and tensest realizations before y, Sherwood's proposed phonemicization would require us to derive [i] from /i/ via a simply in order to account for the failure of lengthening in iy.<sup>10</sup>

A more direct approach, and one which allows us to phonemicize all occurrences of [i] as i, is to suppose that a general rule ordered prior to lengthening converts any sequence of i and y into a structure in which a single element of the segmental tier is linked to two successive timing slots. Since i and y, like o and w, differ only in syllabicity and not in terms of features, this operation amounts to conflating two successive occurrences of the features of i into one:

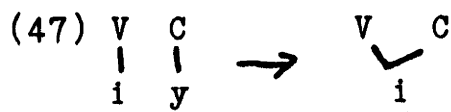

Our hypothesis that penultimate lengthening is not applicable in multiply linked structures will now cover iy as well as the appropriate cases of ow.

The restriction on lengthening in VhV can also be handled by constraining the application of lengthening in multiply linked structures, and in this case no special stipulation is required. In 5.5 we will see that there is extensive evidence for a rule by which a non-high vowel is assimilated to a following vowel across /h/. This rule takes /n-kasse-ha/ to n-késsá-ha (1-in-go) 'I

enter,' but leaves the sequence /ihə/ unchanged in ési<sup>•</sup>-h-ə̀-<sup>̀</sup>k (give.drink-TI-TI-3AN-(PERF)) 'when he watered it.' (For underlying /e/ in /kəsse-/ 'in,' cf. h-kəssé<sup>•</sup>-hl-a-l (3-in-TA-DIR-3.OBV) 'he lets the other in.')

Assimilation in this case may be viewed as the spreading of the non-laryngeal features of the second vowel in /VhV/ onto both the preceding /h/ and the V before it. The output in this case will again be a multiply linked structure, although one of a different form from that postulated above for ow and iy, since three timing positions are involved here and the laryngeal features of h remain distinct from those of the adjacent vowels.

The VhV sequences which result from assimilation have special phonetic properties. The first vowel in such a sequence is usually quite short and is often weakly articulated. In fact, it seems that stress is often phonetically realized on the second vowel in the sequence even when it is phonologically assigned to the first. Thus a word like nkəssáha is frequently heard with stress on the first and third syllables, rather than on the first and second as the accentual notation employed here might suggest. Nonetheless, the pitch contours of such words are consistent with accent assignment as marked. I will therefore assume that phonetic stress patterns which diverge from the expected alignment of stress and pitch in these cases are the result of a low-level rule of stress displacement.

However this may be, it is clear that the first V in VhV does not undergo penultimate lengthening when it has assimilated to the second. Lengthening takes place before hV, however, where assimilation is not applicable, as in ési<sup>•</sup>-h-ə̀-<sup>̀</sup>k 'when he watered

it.' (For another type of case in which assimilation does not take place in VhV, see 8.4.2.)

For the cases at hand, we will again obtain the right results by supposing that penultimate lengthening is not applicable in multiply linked structures. Note, however, that this proposal would allow lengthening of the first V in VhV where the two vowels are the same "by accident," rather than as the result of assimilation. This situation may, in fact, be instantiated by Maliseet á·há 'yes' (and perhaps by some pronunciations of Passamaquoddy áhá, although the variable phonetics of this expression make it difficult to be certain of vowel length here). A long vowel is expected in the first syllable of this word if both a's are underlying and assimilation is blocked for some reason here. (But compare áhá·hs 'horse,' where non-derived aha has a short, weakly articulated first a in both dialects, as expected.) In principle, then, a fully explicit orthography might have to provide for the indication of vowel length before hV as well as for the marginal contrast between o and o· before w.

Let us suppose, now, that a constraint on lengthening in multiply linked structures is the right way to account for the failure of lengthening in iy, ow, and VhV. Two questions then remain: why should there be such a constraint, and how should it be formally implemented?

The proposed restriction is tantalizingly similar to the constraints which Hayes (1984, 1986a,b) and Schein and Steriade (1986) have proposed to account for the well known fact that geminate structures often resist the application of phonological

rules (Kenstowicz and Pyle 1973). If the Passamaquoddy case could be brought under the kind of universal principle that these authors have discussed, then it might be possible to provide a real explanation for the facts that we have been considering. Unfortunately, however, it appears that neither of the proposals which they have put forward is adequate in the present case.

The lengthening of vowels in open penultimate syllables in Passamaquoddy might plausibly be stated in two rules as follows. (For present purposes, we may write an asterisk over a syllable to indicate that it is stressed.)

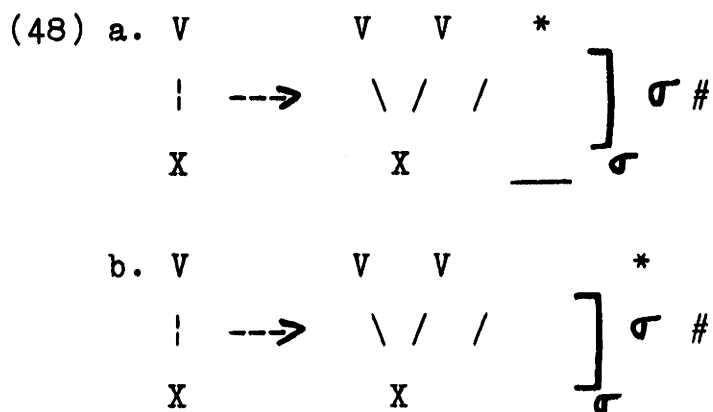

A condition to the effect that  $X \neq \underline{\text{e}}$  must be imposed in some manner on both rules.

The solution to the problem of geminate blocking which Hayes has proposed is the linking constraint: Association lines in structural descriptions are interpreted as exhaustive (Hayes 1984). This constraint will correctly prevent the application of either of the rules of (48) in the multiply linked structures proposed above for iy and ow, and will also correctly rule out lengthening before hV where assimilation has taken place. In each of these cases, the segmental material of the potential



target vowel is linked to more positions on the CV tier than are specified in the structural descriptions of the rules.

The problem with this approach is that the Linking Constraint will also block the application of (48a,b) to the second vowel in a sequence of the form VhV to which assimilation has applied. Since it is the features of this vowel which spread leftward in the assimilation process, this segment will also be multiply linked in the output of assimilation. But penultimate lengthening is applicable to the second V in VhV: n-kássa-há-pàn (1-in-go-11) 'we (du. exc.) enter,' wíco·hke-tahá-m-a-l ((3)-help-think-TA-DIR-3.OBV) 'he thinks of helping the other.'

The constraint proposed by Schein and Steriade is quite different in nature from that suggested by Hayes, although it covers many of the same cases. The details of their proposal need not concern us here. The point which is relevant in the present context is that their Uniform Applicability Condition is explicitly stated so that it is relevant only to rules which change the content of some node in phonological representations (i.e. some feature, segment, etc.) and not to rules which simply alter the "temporal span" of some node (1986:727-728). Since the penultimate lengthening rules (48a,b) are precisely rules of the latter type, Schein and Steriade's constraint cannot help us to explain the observed blocking effects.

It appears, then, that the approaches which are currently available fail to provide an explanation for the constraints on lengthening in multiply linked structures that we find in Passamaquoddy. It is not difficult, however, to encode these restrictions in language-specific rules. Perhaps the most

straightforward way to do this is to formulate the penultimate lengthening rules as shown in (49), so that they require a sequence of distinct segments in the relevant structures.

(49) Penultimate Lengthening

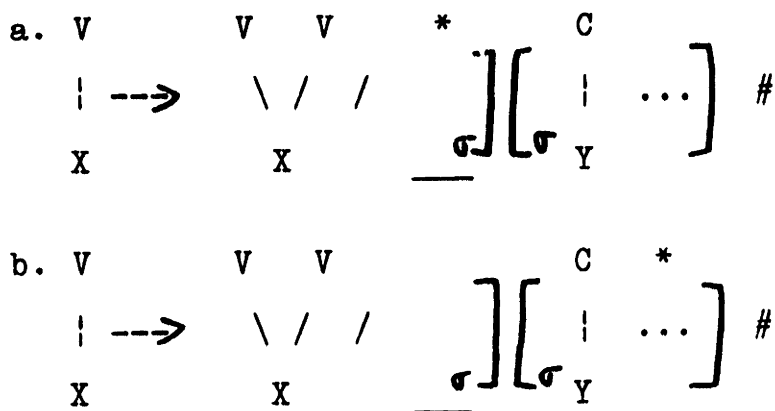

Conditions: X, Y are segments and X is not a.

These rules will not be applicable in multiply linked iy and ow precisely because these structures do not contain distinct i and y or distinct o and w to be analyzed as X and Y. The first V in multiply linked VhV is also ineligible for lengthening by either rule because it is not associated with a segment distinct from that linked to h. The second V in VhV, on the other hand, is linked to a segment which is distinct from that associated with the following C, so both (49a) and (49b) will be applicable in this position. Clearly, then, it is possible to give a descriptively adequate account of penultimate lengthening along these lines, although an explanation of the conditions under which lengthening takes place remains elusive.

### 3.4 Distributional restrictions

Several restrictions on the surface distribution of the phonemes of Passamaquoddy are stated in this section. Additional

regularities of this kind could undoubtedly be discovered. The generalizations which are stated here are primarily those which are relevant to later discussions.

All of the phonemes except ə and h occur initially, medially, and finally in the word. Schwa occurs initially and medially but never ends a word. While h is common medially, it occurs initially before a vowel only in a few words (e.g., həw 'O.K., go ahead,' hək 'body,' həsis 'older brother') and is never found word-finally. Initial hC is common, but h is phonetically [h] in such clusters only when it is syllabified with the final vowel of a preceding word, as discussed in section 1.

No vowel sequences occur within words at the level represented in transcriptions, but iyV and owV are sometimes pronounced with no phonetic glide (frequently so in Maliseet). Some speakers optionally insert h between identical vowels at a word boundary: má (h)əpc 'not again' (P.D.), táma (h)əl 'somewhere or other' (A.H.). Some of these speakers apparently have a more general rule: k-kətóhp-a həpán? (2-want.to.eat-DIR bread) 'Do you (sg.) want some bread?' (P.D.); cf. əpán 'bread' (all speakers). A phonetic glottal stop is also heard between vowels at a word boundary in careful speech, and is common before utterance-initial vowels as well.

The sequences wo and yi do not occur word-initially for most speakers, although some elderly speakers apparently have yíh-i-n for the more common íh-i-n (tell-1.OBJ-2) 'tell (sg.) me!' (Compare yáh-a-n (tell-DIR-2) 'tell (sg.) him/them!') The sequences əw, ow, and iy are excluded word-finally for all speakers, and oy does not occur in any position (although owy is

phonetically [u<sup>v</sup>.y]). The sequence ow does not occur before obstruents, since /ow/ surfaces as oh in this environment: compare cków-ápən (hither-dawn-(3)) 'it is dawn,' ckóh-pé-he (hither-liquid-go-(3)) 'the tide is coming in.'

All speakers have ihi in certain words: ksí-kíhin (intense-sharp-(3)) 'it is sharp,' nt-íhi-n (1-have-3IN) 'I have it,' má te íhi-w (not EMPH be.located-(3)-NEG) 'he, it is not there.' Some speakers also have ihi, optionally or obligatorily, where others have iyi: w-ítápi-yil ~ w-ítápi-hil (3-friend-3.OBV) 'his friend,' má te íhí-wi-yik ~ má te íhí-wi-hik (not EMPH be.located-(3)-NEG-33PROX) 'they (du.) are not there.' The i which follows y ~ h in these examples is derived from /ə/ by a morphologically governed rule which is triggered by a preceding /y/, showing that y is basic in this alternation; compare ətóhk-əl 'deer (obv. sg.),' ətóhk-ək 'deer (prox. pl.).' This rule, too, is optional for a few speakers, who therefore allow w-ítápi-yəl for 'his friend.'<sup>11</sup> In 8.1 we will see that many of the alternating y's are inserted by a rule of epenthesis.

Sequences of two obstruents are subject to few restrictions and may occur initially, medially, or finally. The examples in (50) show something of the range of clusters of this type. A more complete survey of the attested two-member clusters of the language is given in Sherwood (1983b:71-79).

- (50) a. ptáhám 'he hooks a fish'  
tpítaháso 'he thinks'  
cpáhkátám 'he is married'  
pcássalèwèy 'the last one'  
ktákwhámohs 'old man'  
tkéyo 'he, it is cold'  
kwsáwéyo 'it sticks out'  
skwéhkikws 'female animal'
- b. lámíptin 'palm (of the hand)'  
átpe 'the water level changes'  
éckockw 'pumpkin'  
némiyékcik 'they (an.) whom we (exc.) saw'  
níktək 'those (an.)'  
átkíkwe 'he has wrinkles on his face'  
ékwtákwso 'he stops making noise (e.g. talking)'  
cípiyátkwis 'cross (dim.)'  
kíste 'it is finished'
- c. apc 'again'  
nítkw 'my eyebrow'  
póktéwick 'liquor'  
wíkp 'brown ash'  
cíhkanakwc 'turtle'  
nmíhtakws 'my father'  
pílaskw 'paper'  
wást 'snow'  
míts 'eat (sg.)!'

There are special restrictions on the occurrence and phonetic realization of initial clusters of a sonorant and an obstruent as a result of the application of Initial Devoicing. These are discussed in some detail in 5.3. Medial and final clusters of this type are relatively free, however. The examples in (51) show various non-syllabic sonorants before p and k.

- (51) a. t<sup>h</sup>álpáyo 'he is scared'  
 lámpek<sup>w</sup> 'underwater'  
 sín<sup>h</sup>pisiye 'he turns blue'  
 pk<sup>h</sup>átewpiw 'there is mist over the water'  
 np<sup>h</sup>ássànp 'I am full (from drinking)'  
 ímiyèw<sup>p</sup> 'holy water'

- b. w<sup>h</sup>á<sup>h</sup>lkil 'he is nice and big'  
 á<sup>h</sup>m<sup>h</sup>ke 'he plays a game, runs for political office'  
 kí<sup>h</sup>nkás<sup>h</sup>ane 'he has big shoes'  
 w<sup>h</sup>écawawká<sup>h</sup>m<sup>h</sup>n 'he nears it'  
 á<sup>h</sup>ps<sup>h</sup>ák<sup>h</sup>ilk 'when he was small'  
 ná<sup>h</sup>t<sup>h</sup>akehkí<sup>h</sup>nk 'go (sg.) to school!'  
 k<sup>h</sup>emí<sup>h</sup>wk 'when it rained'

Clusters of y and an obstruent do not occur in native words but are sometimes heard in recent borrowings: ht-ápareýt-am-ów-y-a-l (3-operate-TI-AI-TA-DIR-3.OBV) 'he operates on the other (surgically).' (Compare the older borrowing nóspéhpəl 'newspaper,' in which English yp has been replaced by hp.)

Initial and medial clusters of the form hC have been discussed in preceding sections. Final clusters of h- and a sonorant are generally excluded. See 4.5.4 for discussion.

Initial Ch occurs only in a few words: khákən 'door,' nhək 'my body.' Medial Ch is well attested, however:

(52) sáphótin 'injections are being administered'

hpáthámən 'he hooks it'

sákhiye 'he comes into view'

nekwhəm 'he coughs'

hcíshal 'he scrapes the other'

álhəm 'he swims around'

támhikən 'axe'

mánhámən 'hw skims it off'

htáwhike 'he is a good shot'

Most non-geminate clusters ending in a sonorant are excluded, except where they arise initially through the use of one of the personal prefixes /n-/, /k-/, and /w-/. (See 5.3, 5.4 for examples.) The sequences iyw, owy, and owh also occur, but iy and ow are usually realized as long vowels in such combinations.<sup>12</sup> Occasionally there is a schwa-like transition between w and h: sówhéwik [z<sub>o</sub>˥˥·hɛ·wig] ~ [z<sub>o</sub>˥˥w<sup>h</sup>ɛ·wig] 'pack sled.'

All of the non-syllabics except h occur in geminate clusters for all speakers, and some have hh optionally or obligatorily before i. The same speakers have hy in place of yy before other vowels, but in these cases yy is always an option. (The speakers who use variants with h here are those who have ih for iyi, as

noted above, and the speakers for whom hh is obligatory before i are those for whom ih is obligatory for iyi. Some speakers occasionally have yh rather than hh before i. The rules which govern the use of these variants have not been worked out in detail.) Examples of geminate consonants were given in 3.2. The geminate glides and their major variants are illustrated in (53).

- (53) htáwwikhíke 'he knows how to write'  
 péciyyik ~ pécihhik 'they (du.) arrive'  
 máceyyik ~ mácehhik 'they (du.) leave'  
 táláyye ~ táláhye 'he is playing'  
 máceyyà ~ mácehyà 'he (abs.) has left'

True geminates occur only medially and finally, with geminate sonorants restricted to medial position. When the first person prefix /n-/ is added to a stem beginning with /n/, resulting /nn/ is simplified to n: compare nán-am ((1)-know-TI) 'I know a lot,' nán-am (know-TI-(3)) 'he knows a lot.' When the second person prefix /k-/ is added to a stem beginning with /k/ or /kw/, the result is as short consonant, even after a vowel-final word; but this segment seems to be somewhat more tense than a simple initial k or kw before a vowel. I therefore write initial kk and kkw in such cases: k-kísis 'your (sg.) aunt,' k-kwátákən 'your (sg.) throat.'

Clusters of three non-syllabics are usually of the form CsC, with k or kw as the final C in almost all cases.<sup>13</sup> They may occur initially, medially, or finally. Most of the attested types are illustrated in (54).



- (54) a. pskihkw 'blade of grass'  
pskwəcis 'war club'  
kspison 'belt'  
kskəmihike 'he takes a shortcut'  
kskwəpəhsan 'it rains and snows at the same time'
- b. nipskətəwe 'he curses'  
sísəlapskwehtikən 'frying pan'  
kəkskos 'cedar'  
ntekskwin 'I sneeze (Subordinative)'  
nəkwsikwéssəss 'woodcock'  
nímskéhe 'he drops by to visit'  
əmskwəcéhkan 'doll'  
málskwəsítəl 'beans'  
siwskowaso 'he is tired of waiting'
- c. pənapskw 'rock'  
nəksw 'young woman'  
nisinsk 'twelve'  
skəlonskw 'bullet lead'  
ksiwsk 'hemlock'

Clusters of the form CCh are attested in a handful of stems:  
h-pésk-h-a-l (3-shoot-TA-DIR-3.OBV) 'he shoots the other,'  
sónkháhso 'he (a dog) rolls around in the dirt' (analysis  
unknown), kákawí nkhapó-hpən (nearly(?) blind-(3)-PRET) 'we was  
more nearly blind.' An additional item of this type and a single  
example of a four-place cluster were given by one speaker (A.H.)  
for whom the AI plural final -həti- appears to have undergone

analogical extension into phonological contexts where it is otherwise excluded: n-póc-cák-p-hatì-p n (1-wet-messy-liquid-PL-11) 'we (pl. exc.) get all wet,' sómskw-háta-w-ək (spit-PL-3-33PROX) 'they (pl.) spit.' (See 4.6 for some discussion of the plural finals and their usual distributions.)

The cluster sks is attested in tál-ask-s-áwe (ongoing-grass(?)-cut-AI-(3)) 'he is cutting grass' and l-ásk-s-awá-kən (thus-grass(?)-cut-AI-NOM) 'scythe,' but some speakers instead have ks in these words: tálaksáwe, laksawákən (A.H.). For some speakers, reanalysis of the output of syncope in certain stems has lead to the creation of novel initial clusters in prefixed forms: n-sp-p (1-above-sit) 'I sit up high,' for older nt-ásp-əp; n-cpáhkatəm (1-married) 'I am married,' for older n-cápkátəm (all forms A.H.). These initial clusters are usually eliminated, however, by dropping the prefix consonant.

### 3.5 Accent

Both the location of the stressed syllables in a word and the pitch or pitch contour associated with stressed syllables in certain positions in the word are distinctive in Passamaquoddy. In addition, unstressed final syllables, which are usually pronounced on a relatively high pitch in utterance-final position, are distinctively low-pitched in a small class of verb forms.

The accentual notation which I use here is adapted from one which Ives Goddard (1970) proposed for Maliseet, although my use of this notation differs considerably from his. (A comparison of the two systems is given in Chapter 10.) The acute accent (´)

indicates a relatively high-pitched stressed syllable. The grave accent ( ` ) indicates a relatively low-pitched stressed syllable, except that word-final syllables which bear this accent are pronounced with a rising intonation before a pause. The circumflex accent ( ^ ) indicates a distinctively low-pitched final unstressed syllable.

The examples in (55)-(67) illustrate the types of accentual contrasts which are found in the language. To make it easier to see how the intonation pattern of the word can be determined from the notation, I have provided a schematic diagram of the pitch contour of each form. (There is some dialect variation in the details of these pitch contours, as discussed below.)

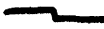
(55) a.   
           tá'k-e  
           hit-AI-(3)  
           'he hits'

b.   
           təké  
           'now'

(56) a.   
           kát  
           'leg (including the foot)'

b.   
           kát  
           'eel'

(57) a.   
nót-əm  
(1)-hear-TI  
'I hear'

b.   
n-ótəm  
1-smoke  
'I smoke'

(58) a.   
n-tól  
1-canoe  
'my canoe'

b.   
n-tól  
1-canoe-(3.IN.ABS)  
'my canoe (abs.)'

(59) a.   
əpo  
sit-(3)  
'he sits'

b.   
əpo  
sit-(3)-(33.OBV)  
'the others (du.) sit'

(60) a.   
n-mihtakws  
1-father  
'my father'

b.   
n-mihtakws  
1-father-(3.AN.ABS)  
'my father (abs.)'

(61) a.   
was-is  
child-DIM  
'child'

b.   
was-is  
child-DIM-(33.OBV)  
'children (obv.)'

c.   
was-is  
child-DIM  
'child (voc.)'

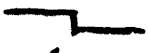

(62) a.   
 mil-a-n  
 (3)-give-DIR-PEG  
 'he gives it to the other'

b.   
 mil-a-n  
 give-DIR-2  
 'give (sg.) it to him!'

(63) a.   
 ma apc nat-ame-w  
 not again (1)-go-fish-NEG  
 'I will not go fishing again'

b.   
 ma apc nat-ame-w  
 not again go-fish-(3)-NEG  
 'he will not go fishing again'

(64) a.   
 n-kisi-hpi-hpən  
 1-past-eat-PRET  
 'I ate'



b.  ~   
 n-kisi-hpi-h-pən ~ n-kisi-hpi-h-pən  
 1-can-eat-NEG-11  
 'we (du. exc.) cannot eat'

(65) a.   
 é<sup>ˈ</sup>lǝmi-ya<sup>ˈ</sup>-li-t  
 away-go-OBV-3AN  
 'when the other goes away'

b.   
 é<sup>ˈ</sup>lǝmi-ya<sup>ˈ</sup>-li-t  
 away-go-OBV-3AN-(PERF)  
 'when the other went away'

(66) a.   
 nat<sup>ˈ</sup>-ǝkehkim<sup>ˈ</sup>-ke-n  
 (1)-teach-PASS-SUBORD  
 'I go to school (Subordinative)'  
 ("I go somewhere to be taught")

b.   
 nat<sup>ˈ</sup>-ǝkehkim<sup>ˈ</sup>-kè-n  
 go-teach-PASS-2  
 'go (sg.) to school!'  
 ("go somewhere to be taught!")

- (67) a.   
 nát-əkehkím-a  
 (1)-go-teach-DIR  
 'I go somewhere to teach him'
- b.   
 nát-əkehkím-à  
 (3)-go-teach-DIR--(33.OBV)  
 'he goes somewhere to teach the others'
- c.   
 nát-əkehkím-â  
 go-teach-3PASS  
 'he goes to school'  
 ("he goes somewhere to be taught")

Cases in which lexical items are distinguished by accent, as in (55)-(57), are relatively rare. More frequently, accentual differences distinguish particular inflected forms of a single lexical item, as in (58)-(67). The items in (55) are the only words that I have found which are distinguished solely by the position of the acute accent. Typically, accentual contrasts involve a difference between the pitch of stressed syllables or differences in both the location and pitch of stressed syllables. Except in vocatives like (61c), which have a special intonation pattern, the grave accent occurs only on the rightmost stressed syllable of a word. The circumflex accent occurs only on the final syllables of certain third person "passive" forms of the



Independent Order (those which are made with the suffix -a 3PASS where this morpheme is subject to no accentual modifications).

Unstressed initial syllables are usually pronounced on a fairly high pitch, as are unstressed syllables which follow the last stressed syllable of the word, apart from those final syllables which bear the circumflex accent. Thus words like əpán 'bread' and ítəmok 'they (du.) say' are pronounced with nearly level intonation, as are both items in (55) above. Unstressed syllables between stressed syllables which bear the acute accent are relatively low-pitched, so that the syllables of a word like wícohkétahámál 'he thinks of helping the other' are alternatively relatively high and relatively low, except that there is only a slight drop in pitch onto the final syllable of this word.

Passamaquoddy speakers fall into two groups with respect to the treatment they accord unstressed syllables between a syllable bearing the acute accent and one bearing the grave accent in words like nátəkéhkimkèn 'go (sg.) to school!', éləmíyalìt 'when the other went away,' and nátəlohkiyà 'he (abs.) has gone to work.' My consultants from Indian Township have high pitch on these syllables, while those from Pleasant Point have low pitch here. (The schematic pitch contours shown in (63)-(65) represent the speech of the Indian Township group, while those in (66)-(67) are typical of forms that I have recorded at Pleasant Point.) Since my consultants come from a relatively small number of families, however, it is possible that differences between extended family groups rather than geographical dialects are reflected in this split.

Maliseet dialects generally appear to make accentual distinctions among the same lexical items and grammatical categories as Passamaquoddy, although the particular phonetic contrasts are not always the same in the two branches of the language. Sherwood (1983b:63-68) has suggested that stress and pitch are not contrastive for some Maliseet speakers from the Tobique reserve, although Tobique speakers whom I have heard seem to use essentially the same patterns of stress and intonation as speakers from Woodstock and Kingsclear, N.B., or from the vicinity of Houlton, ME, all areas where accent is clearly distinctive. The status of accentual contrasts in Maliseet clearly merits a thorough study.

The phonetic correlates of accent are somewhat different in Maliseet and Passamaquoddy. A few comparative remarks may therefore be helpful for interpreting the Woodstock material which is cited at various points in this work.

While a Passamaquoddy monosyllable like wík 'his house' which bears the acute accent is pronounced on a high pitch with level intonation (and a short vowel), the same word in Woodstock Maliseet is pronounced with a sharply falling intonation (and a long vowel). Monosyllables which bear the grave accent are pronounced in the same fashion in the two dialects, however: on a low pitch, with level intonation before further material but with rising intonation before a pause (and with a short vowel in either case).

In a disyllabic word like skítap 'man' in Passamaquoddy, the first syllable is level and high and there is a sharp drop onto the second syllable, which again has a rising intonation before a

pause. In Woodstock Maliseet, on the other hand, skítap is pronounced with a sharply falling intonation on the first syllable. (In both dialects, the first syllable of this word has a long vowel.) The Passamaquoddy word sákəm 'chief' has the same stress and intonation as Passamaquoddy skítap. In Woodstock Maliseet sákəm, however, the first syllable starts on a low pitch and is pronounced with a rising intonation, while the second is unstressed and moderately high.

In Woodstock Maliseet étəlíhtemman 'when I was hitting it,' the two syllables which bear the acute accent are relatively high in pitch, while the syllable between them is relatively low. The unstressed penultimate syllable is pronounced with a falling intonation, while the stressed final syllable has a rising intonation. Schematically:

(68) —      —      \      /  
           é    tə   líh    tem    mán

Compare nicannok 'our (exc.) children,' with rising intonation on the penultimate syllable:

(69) —      /      —  
           ni    can    nok

One characteristic feature which distinguishes Maliseet intonation patterns from those of Passamaquoddy results from a general rule of Antepenultimate Lowering: high pitch is replaced by low pitch on an antepenultimate stressed syllable, provided that it is the last stressed syllable in the word. Thus we have

Woodstock Maliseet ítámok 'they (du.) say,' ímiyewikáwam 'church' for Passamaquoddy ítámok, ímiyewikáwam. There are some traces of a comparable process in the phonology of Passamaquoddy, perhaps now morphologically governed. I have occasionally recorded forms with low pitch on an antepenultimate stressed syllable where the usual intonation patterns of the language would call for high pitch: nt-ówhém-əno-k (1-pet-11-33PROX) 'our (exc.) pets,' k-míl-1-əni-ya (2-give-2.OBJ-PEG-22) 'I give it to you (pl.).'

Woodstock Maliseet forms which correspond to Passamaquoddy passives with final low-pitched unstressed syllables are pronounced with low pitch on the last stressed syllable of the word instead, and are therefore written with the grave accent rather than the circumflex: Passamaquoddy pécí-ph-â, Woodstock Maliseet pécí-ph-a (arrive-carry-3PASS) 'he arrives by vehicle' (literally "he arrives by being carried").

Goddard (1970:1-2) hypothesized that writing one accent per word would usually be sufficient to distinguish among the contrasting prosodic patterns of Maliseet, although he noted that it might sometimes be necessary to mark additional accents in words in which certain "short-vowel syllables" (syllables with the vowels "ə" and "ʌ," both transcribed here as ə) receive irregular treatment in accent assignment. The cases in question involve schwas which are always stressable regardless of their phonological context. In Chapter 4 we will see that such "inherently stressable" schwas are in fact quite common. Thus a minimal accentual notation will indeed require marking more than one accent in a substantial number of words.

I have not attempted to reduce accent marking to a minimum in this work, however. Since it is precisely the rules by which accent may be predicted which will concern us in much of what follows, the use of a minimal notation would inevitably leave the reader to carry out complicated calculations in many cases in order to determine the data which are under discussion. Thus it has seemed better for expository purposes to mark accent as fully as possible. In future work on Maliseet and Passamaquoddy, however, it will undoubtedly be desirable to develop a more economical system for transcribing accent.

Phrase and sentence level stress and intonation are largely ignored in this work. I should point out, however, that a distinctive sentence-final high pitch occurs in questions of all types, where it causes a general raising of the pitch of the last stressed syllable and any following unstressed syllables in the sentence.

-- Notes --

1. Sherwood reports [U] and [U ] before w, the relevant environment, but I hear tenser vowels in this position in Passamaquoddy and in Woodstock Maliseet than this notation suggests. I also hear high, tense [i] before y in Passamaquoddy and Woodstock Maliseet, while Sherwood (1983b:63) reports [I] in this context.

2. áhpi and íhpi are irregular (?) contractions of áhtal-ápi-t (keep.on-sit-3AN) 'he keeps on sitting (Conjunct)' and íhtal-ápi-t (usually-sit-3AN) 'where he usually sits,' respectively.

3. The decision to write ə in these cases might well be questioned, since there are undoubtedly words in which I have transcribed ə where I have never actually heard this vowel. There seems to be no sharp line, however, between words like matahkamikok 'Peter Dana Point,' which I have heard with phonetic ə in hkam only in singing, and others like pəsənot 'basket,' whose second ə is usually retained except in rapid speech.

4. Note, however, that the cluster which results when a is phonetically omitted in initial pam is realized as an m initiated by a sudden lowering of the velum.

5. Initial h in Passamaquoddy forms like (7a) is derived from /w/ by Initial Devoicing (see 5.3.5). This rule is optional in the speech of Peter Lewis Paul, who provided the Maliseet forms. The accentual differences between the Maliseet and Passamaquoddy examples given here appear to reflect the application of the Maliseet Antepenultimate Lowering rule (discussed in section 5 below) at a stage in derivations prior to the application of the rules of syncope which give rise to the geminate sonorants in most of these examples. This proposal is developed in further detail in LeSourd (1982).

6. Possibly a undergoes lengthening in ahC in the Conjunct negative endings where such sequences occur. See 6.5 for ahC in Passamaquoddy.

7. Phonologically, [V•hC] might be taken to represent [Vh•C], if we suppose that h is lengthened before another non-syllabic as other non-syllabics are. As it stands the statement of lengthening given in section 1 makes h an exception in this regard.

8. Note that we must suppose that morpheme-internal ow is not subject to a restriction like the Obligatory Contour Principle of McCarthy (1986), since the long vowel of mó•win 'bear' shows that ow is not necessarily a multiply-linked structure within a morpheme.

9. If /a/ is represented as a root node without any associated features, then no deletion operation will be required to set the stage for feature spreading. If, on the other hand, /a/ is underlyingly fully specified, then it seems likely that only the features that distinguish this vowel from /o/ are deleted and that only these feature of /o/ spread. The output of assimilation will then be a multiply linked structure of a more complex type than that shown in (29). These observations do not affect the point of the argument in the text, however.

10. Sherwood apparently also intends his phonemicization of [Iy] as ay to account for the fact that i before y is sometimes treated like (underlyingly unstressable) a by the rules of stress assignment. We will see in Chapter 8, however, that the treatment of i before y is not uniform in this respect. Thus Sherwood's proposed rule changing /i/ to /a/ before /y/ makes incorrect predictions about stress placement.

11. The suffixes -akw (a word-final allomorph of the Inverse theme sign) and -at (second person singular on third person, Conjunct) are exempt from fronting after /y/ for all speakers: nami-y-akw ((1)-see-TA-INV) 'he sees me,' nami-y-at (see-TA-2/3(3)) 'he whom you (sg.) see.'

12. The sequence ym occurs in Changed forms of the verb /ih-am-aw-/ TA+O 'have X of Y's': ey-m-a-ht (have-TI-TA-3(3)OBV/3PROX-(PERF)) 'when the other had something of his.' ey replaces iy in Changed forms of ht-iy-w-a-l (3-have-TA-DIR-3.OBV) 'he has the other'; ey-w-a-t (have-TA-DIR-3AN-(PERF)) 'when he had the other,' ey-a-ht (have-TA-3(3)OBV/3PROX-(PERF)) 'when the other had him.' (See 9.3 for some discussion of these verbs.)

13. I have encountered one example of a three-place cluster with final member t: cik~~ə~~nakwstek 'it (skin) is hard' (Mikcic, pp. 15, 26). The analysis of this form is not known to me. It appears to be a pun on cihk~~ə~~nakwc 'turtle.'

## Chapter 4

### Stress Assignment

Within a large class of cases, the stress patterns of Passamaquoddy words can be predicted on the basis of two simple principles, which may be stated as a rule assigning stress to word-initial syllables and a right-to-left alternating stress rule:

(1) Initial Stress Rule (ISR)

Stress the first syllable of a word.

(2) Alternating Stress Rule (ASR)

Stress the even-numbered syllables of a word, counting from right to left.

These rules can in fact be collapsed into a single statement if we adopt a theory of stress which recognizes the foot as a constituent of metrical structure. Even without this reduction, however, the stress system represented by (1) and (2) is a simple and natural one.

Despite the fact that (1) and (2) are easily motivated, the surface stress patterns of the language are much more complex than we would expect on the basis of these principles alone. Sometimes a word-initial syllable remains unstressed and the second syllable of the word is stressed instead. Sometimes one



or even two extra syllables must be skipped over in assigning alternating stress. A close examination of these cases reveals a regular but quite disparate set of conditions which determine when a particular syllable will be counted in assigning stress and when it will be skipped over or left "out of the count."

The central purpose of this chapter is to identify these conditions and to explore three hypotheses about the nature of the system from which they follow. As we will see in following chapters, the principles of this system not only play a central role in the process of stress assignment in Passamaquoddy, but in fact serve to organize much of the phonology of the language.

One potentially misleading point of terminology should be made clear at the outset. I will refer to vowels which are "visible" to the stress rules, either in the sense that they are available for stress assignment or in the sense that their presence is taken into account in figuring stress placement, as stressable vowels. Those vowels which are "invisible" to the stress rules -- whose presence is simply ignored in assigning stress -- I term unstressable vowels. The reader should bear in mind that stressable vowels, in this sense, are not necessarily stressed. (We will see, however, that certain assumptions about the nature of the stressable/unstressable distinction might lead us to say that all stressable vowels bear some degree of stress.)

In surface forms, unstressable vowels are usually ə, although some occurrences of i before y are also skipped over in stress assignment. As we will see, however, the unstressable vowels which appear in surface forms are a subset of the segments which must be classed as "underlyingly unstressable." In this

chapter, we will be concerned primarily with unstressable /ə/. In later chapters, I will argue that some underlying occurrences of /i/, /a/, and /o/ are unstressable as well. Many underlyingly unstressable vowels become available to the stress rules ("become stressable") as the result of phonological operations. Others are subject to syncope. (Unstressable vowels are also sometimes introduced by rule.)

The /ə/ of the stem /kəlol-/ TA 'argue with' may serve as an example. This segment is ignored when stress is assigned in the reciprocal form kəlól-tó-w-ək (argue-RECIP-3-33PROX) 'they (du.) argue with each other,' so that stress is assigned to the second syllable of this word by the ISR. We will account for this fact by postulating an underlying form for /kəlol-/ in which this /ə/ is an unstressable vowel. No rules are applicable in the derivation of kəlól-tó-w-ək which change the status of this segment, so it remains invisible when stress is assigned. The situation is different in the related form h-kəlól-tí-ni-ya (3-argue-RECIP-PEG-33PROX) 'he argues with the other.' Here the /ə/ of /kəlol-/ follows an underlying cluster which triggers a phonological rule that makes underlyingly unstressable vowels stressable. This /ə/ is therefore visible when the stress rules are applied, so the first syllable of h-kəlól-tí-ni-ya receives stress. Note, however, that the i of the "peg" or filler morpheme -ni- is unstressable here. (We will see in Chapter 8 that this vowel is a stressable /e/ in underlying forms but becomes an unstressable /i/ through another phonological process.) Because this i is not accessible to the stress rules,

stress is assigned to the antepenultimate syllable of h-kálol-tí-ni-ya by the Alternating Stress Rule.

Now it is important to note that unstressable vowels are not in general epenthetic (although we will see in Chapter 7 that some of them are). We find unstressable ə in əpó (sit-(3)) 'he sits' and təké 'now,' for example, but these schwas must be present in underlying forms: any number of words start with p, and tk is a common initial cluster, so no general rule can be responsible for inserting these segments. The unstressable vowels that we find within stems must be present in underlying forms if we are to account for the distribution of connective /i/, the epenthetic vowel which breaks up underlying clusters at stem-internal boundaries. (The rule which inserts connective /i/ is discussed in 6.6.1.) Note also that unstressable ə alternates with stressable ə in the derivatives of /kəlol-/ which were cited just above. Clearly, then, we are not dealing here with a situation in which stress is assigned before the insertion of a class of epenthetic vowels, which therefore never "count" for stress placement. (In Chapter 5 we will look at cases in which ə alternates with zero under conditions which involve the stressable/unstressable distinction. We will see in 5.1, however, that these alternations reflect the application of a class of deletion rules, not a complementary process of epenthesis.) Our theory of "stressability" must accommodate the fact that the same underlying segment may count in stress placement in some words but not in others.

Three accounts of the distribution of stressable and unstressable vowels will be developed in this chapter. All three

are based on the assumption that generalizations (1) and (2) should be stated within some type of metrical theory of stress assignment. (The choice of a particular variant of metrical theory will not in fact play a crucial role in the discussion.) They differ only in the mechanisms which they posit in order to account for stressability. In effect, we will be trying to decide among competing theories of the system of rules which construct the representations which then serve as inputs to (1) and (2).

The first of these accounts uses a diacritic feature [strong] to distinguish between stressable and unstressable vowels. This treatment is intended as a formalization of the descriptive practice of a number of Algonquianists who have worked on similar problems in various languages, notably Ives Goddard (working on Delaware) and David Sherwood (working on Maliseet).

In the second analysis, the metrical theory which accounts for (1) and (2) is augmented by positing an additional level of metrical structure which states the stressable/unstressable distinction in terms of relative metrical prominence. This hypothesis represents a tradition of work within the metrical framework which goes back to hypotheses that Nancy Chinchor and I first put forward in 1978.

The third proposal exploits the power of CV phonology, which allows us to distinguish between floating segments and segments which are linked to positions on the CV or timing tier. (Once again, most details of the theoretical framework are not crucial. Any theory of the timing tier which permits us to have floating

segments would probably work as well.) Here the central hypothesis is that unstressable vowels are vocalic segments which are not associated with slots on the CV tier at the point in derivations at which the stress rules apply: they are invisible to the stress rules because stress is assigned either directly to elements of the timing tier or to syllables, which are organized in terms of elements of the timing tier. Stressable vowels are segments which are linked to V-slots at this stage. The leading ideas of this approach are derived from the work of Michelson (1986) on stress in Mohawk.

All three of these models can handle the basic facts of stress assignment. I will argue, however, that the three proposals are not equivalent in explanatory power. It is relatively easy to show that the theory which uses a diacritic feature to state the distribution of stressable and unstressable vowel cannot be right. The complex manipulations of the feature [strong] which turn out to be required on this account should undoubtedly be ruled out by any theory of grammar which places substantive restrictions on the kinds of phonological patterning which can be called regular. It is more difficult to choose between the metrical and CV theories of stressability. I believe, however, that a consideration of the role of syllabification in the conditions which determine stressability favors the CV approach.

Because comparing the explanatory force of the metrical and CV theories of the stressable/unstressable distinction does not provide as clear a basis as we would like for choosing one over the other, we would prefer to find a way to distinguish between

them on empirical grounds. In Chapter 8 I will demonstrate that there is in fact empirical evidence which favors the CV-theory over both the diacritic and metrical accounts. The evidence in question comes from words whose underlying forms contain sequences of a stressable vowel and an unstressable vowel. This evidence can only be interpreted, however, after we have seen how we would want to handle syncope within the different frameworks. This issue is taken up in Chapters 5 and 6.

The discussion in this chapter is limited to forms in which all stressed syllables are high-pitched. In Chapter 10 we will see that the stress patterns of words containing low-pitched stressed syllables are phonological transforms of stress patterns like those discussed here.

The present chapter is organized as follows. Section 1 presents evidence that (1) and (2) do in fact state important generalizations about stress assignment in Passamaquoddy and then provides a formalization of these generalizations, together with the machinery which accounts for stress subordination in pre-pausal forms. Section 2 states the facts about the distribution of stressable and unstressable vowels which any theory of Passamaquoddy stress must account for. Sections 3, 4, and 5 develop the three alternative analyses of the stressable/unstressable distinction which I will consider in this study. Section 6 is concerned with I-Mutation, a morphologically governed rule which derives unstressable /ə/ from stressable /i/ before /w/. A rule of Stress Shift which accounts for the pattern of stress subordination found in non-final forms is formulated in section 7.

#### 4.1 Stress assignment and stress subordination

Applied together, the Initial Stress Rule and the Alternating Stress Rule produce stress patterns like those shown in (3).

- (3) a. wícohké-m-a-l  
(3)-help-TA-DIR-3.OBV  
'he helps the other'
- b. wíc\_óhke-kémo  
help-AI-(3)  
'he helps out'
- c. wícohké-tahá-m-a-l  
(3)-help-think-TA-DIR-3.OBV  
'he thinks of helping the other'

The role of a right-to-left syllable count in stress assignment is clear from examples like (4)-(6), in which the stress of non-initial syllables varies with the addition of suffixes.

- (4) a. wás-is  
child-DIM  
'child'
- b. wás-ís-ək  
child-DIM-33PROX  
'children'

- (5) a. tópkwan  
       'dirt, soil'  
       b. tópkwán-amkw  
           dirt-particulate  
           'dirt, soil'

- (6) a. pé-m-skót-e-k  
       along-field-II-3IN  
       'field'  
       ("where a field is located through a length")  
       b. pé-m-skot-é-k-il  
           along-field-II-3IN-33IN  
           'fields'

Adding syllables at the beginning of a word does not induce comparable stress shifts. Stress remains on the penultimate syllable wes in (7a-c) regardless of the number of syllables which precede it.

- (7) a. l-éwéstó  
       thus-speak-(3)  
       'he speaks'  
       b. wík-ewéstó  
           like-speak-(3)  
           'he likes to talk'  
       c. séhtáy-ewéstó  
           backwards-speak-(3)  
           'he speaks while walking backwards'<sup>1</sup>



The basic principles of stress assignment represented by the Initial Stress Rule and the Final Stress Rule could probably be formulated equally readily in terms of metrical trees, metrical grids, or a combination of the two. Metrical accounts of stressability have generally assumed that metrical structure is organized into constituents. I will therefore adopt a tree-based framework in discussing proposals of this type in 4.4. On the other hand, if the distinction between stressable and unstressable vowels is better expressed in non-metrical terms, as I argue in 4.5, then the theory of stressability will not in itself provide evidence either for or against constituent structure in metrical representations.

The grid-based stress theory of Selkirk (1984) appears to offer certain advantages for the analysis of stress and stress-related phenomena in Passamaquoddy. I suggest in 4.5.1 that the properties of the grid as a representation of timing relationships provide the basis for an explanatory account of the phonetic reduction of unstressable a. The rule of Stress Shift discussed in 4.7 is easily stated as an operation on grids, but a statement of the rule in terms of trees would require us to postulate more structure for word trees than otherwise appears to be motivated. I will therefore tentatively adopt Selkirk's framework here, although I will also try to note points in the analysis where it might be useful to allow reference to metrical constituent structure.

Following the procedures which Selkirk has suggested, the first step in constructing the metrical grid for a word is to align each of its syllables with a grid position or "demibeat."

Consider, for example, the word téhsákw-apas-ol'tí-ne (on.top-pl.walk-PL-11) 'let's (pl.) walk around on top.' In (8), each syllable of this word has been aligned with a demibeat, indicated by an "x."

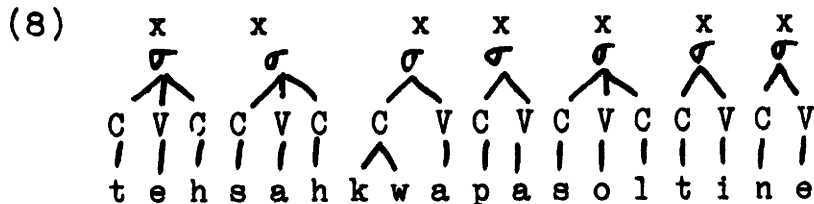

The ISR and the ASR are restated in (9) and (10) as rules which align particular demibeats in a word with "beats," positions in the metrical grid above the demibeat level.

(9) Initial Stress Rule

Align the first demibeat of a word with a beat.

(10) Alternating Stress Rule

Align every other demibeat in a word with a beat, starting with the penultimate demibeat and working leftward.

Applying these two operations to the representation shown in (8), we derive (11).

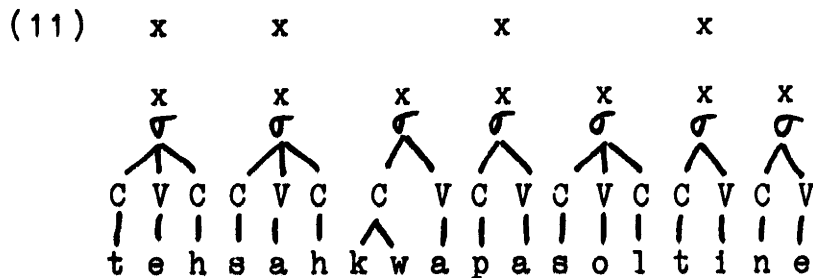

This gives us the right distribution of stressed and unstressed syllables for this word.

Note that (9) and (10) can be combined into a single statement if we introduce the notion of the metrical foot into our analysis: we need only construe the ASR as a rule which assigns binary-branching feet from right to left in a word as far as possible, then designates any remaining word-initial syllable as a foot in itself. If the left-hand (or only) syllable in each foot is stressed, we obtain the same stress pattern for téhsáhkwápasoltíne as that shown in (11). Since it is not clear to me that there is any other work for the foot to do in Passamaquoddy, however, I will not pursue this matter here. Our principal concern will be with the system of rules which construct the input to stress assignment. For this purpose, it is not necessary to determine the status of the foot in metrical theory.

Now the stresses assigned by (9) and (10) are not all realized with equal strength. Primary stress occurs on the rightmost stressed syllable of a word in pre-pausal position. This fact is stated as the Main Stress Rule (12). (A rule of Stress Shift, formulated in 4.7, is applicable in non-final forms.)

(12) Main Stress Rule

Align the rightmost beat in a word with a beat  
on the next higher metrical level.

The result of applying (12) to (11) is (13)

(13)

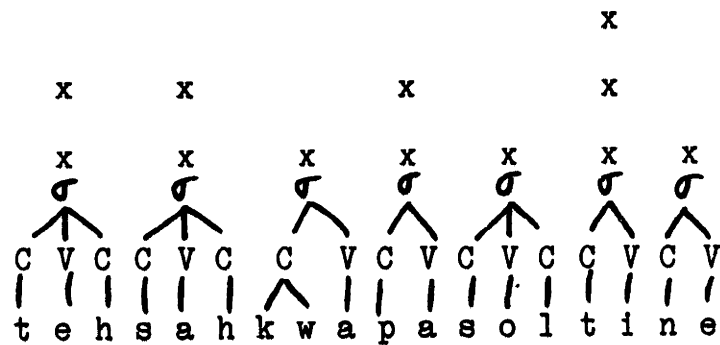

The structure in (13) contains a stress clash: the first two beats in the word are equally strong and are not separated by a grid position on the next lower metrical level. This clash is often, but not obligatorily, eliminated by giving the first of the clashing beats greater prominence than the second.<sup>2</sup> It is not really clear whether this effect is achieved by increasing the strength of the first beat or by reducing that of the second. I will assume here that the first of these options is taken.

The required grid adjustment is stated in (14), a rule which aligns the first of two clashing beats with a third-level grid position. By convention, in Selkirk's system, a rule like (14) is not permitted to eliminate the relative prominence of a beat which was promoted to the third level by a rule like our Main Stress Rule (12). The latter is automatically aligned with a beat on the fourth level upon the promotion of another beat to the third level. If we adopt this convention for Passamaquoddy, then the effect of applying (14) to (13) will be (15). This result is empirically correct: the rightmost stress in the utterance-final pronunciation of téhshákwapásoltíne is the strongest, regardless of the relative prominence of the first two syllables of the word.



Prince (1983:72), I will assume that the generally increasing pitch of the secondarily stressed syllables in a form like this is a reflection of intonational principles alone and does not indicate increasing metrical prominence. Thus only stresses promoted to greater prominence by the Main Stress Rule and Clash Avoidance are distinguished from other stresses in the metrical structures assumed here.

Finally, I should note that the domain of stress is sometimes larger than the word. In particular, a preverb or prenoun may form a single stress domain with the word it modifies, provided that the two are adjacent, although these collocations are presumably phrasal, since they can usually be interrupted by other words in a clause.<sup>4</sup> The final stress of the preverb kisi 'past, finished' and the pre nouns ktamaki 'poor, unfortunate' and sokəl-is-i 'candy' in (16) is unexpected if any of these elements forms a stress domain by itself, but this pattern is predicted in each case if the modifier and the following word are stressed as a single unit.

- (16) a. n-kísi' not-əm-ən-əl  
 1-past hear-TI-3IN-33IN  
 'I heard them (in.)'
- b. ktámaki' skitápi-hil  
 poor man-3.OBV  
 'the poor man (obv.)'
- c. sókəl-is-í' apətó-h-on  
 sugar-DIM-PN lean-TA-NOM  
 'candy cane'

A combination of this kind may be treated like a single word for the purpose of stress assignment even when other phonological processes treat the modified noun or verb as a word in itself. The examples in (17) are a case in point. Initial Devoicing, a rule which will be discussed in 5.3, has the effect of changing word-initial n to h before a voiceless consonant, but does not affect medial n. Yet n alternates with h in these forms, despite the fact that the preverb noci 'as an occupation or regular activity' forms a single stress domain here with the following verb.

- (17) nóci'            ntop-t-áhsi-t  
 ~ nóci'            htop-t-áhsi-t  
 occupation catch-TA-AI-3AN  
 'catcher (in baseball)'

Thus the rules and conventions which have been formulated above as governing the stress patterns of words should probably be

recast in terms of stress phrases. For expository convenience, however, I will continue to speak of the stress rules as applying to words except where the distinction between words and phrases is directly relevant.

#### **4.2 When /ə/ counts for stress placement**

Departures from the stress patterns that we expect on the basis of (1) and (2) are found in words in which there are one or more "unstressable vowels," usually /ə/, whose presence is simply ignored in assigning stress. It is often possible to determine on the basis of general principles whether a given occurrence of /ə/ will be included in figuring syllable counts for stress placement. In certain morphemes, however, particular occurrences of /ə/ are always counted as stressable. These schwas are treated just like the majority of non-schwa vowels in stress assignment: they figure into the syllable counts which determine stress placement regardless of the phonological contexts in which they occur. I will refer to vowels like these which are stressable in all environments as "inherently stressable."

Schwa is always treated as stressable if it occurs in any of the following environments:



- (18) a. it is the last vowel of a word
- b. it follows a cluster of non-syllabics other than /hC/ (with some exceptions involving geminates)
- c. it follows /hl/
- d. it stands between /s/ and /hs/
- e. it is the first /ə/ in a word-initial sequence of the form /((C) ə [+sonorant] ə / in which the second /ə/ is unstressable
- f. it is in an even-numbered position, counting from left to right, in a maximal series of /C<sub>n</sub>ə/ sequences in which no /ə/ falls under conditions (a)-(e) or is inherently stressable.

These conditions are explored in detail in the following pages.

#### 4.2.1 Basic conditions for stressability

The first clause of (18) is illustrated in (19)-(21). The examples in (19) and (20) show how the stress of the non-initial syllables of a word changes with the addition of a suffix containing /ə/. In (21) a similar shift in stress takes place when the suffix /-t/ ʒAN is replaced by /-mək/ UNSPECIFIED SUBJECT. In each case, the /ə/ of the suffix is a stressable vowel in the sense that its presence affects the way in which the stress rules apply. Of course none of these schwas is itself in a position to receive stress by either the ISR or the ASR.

- (19) a. tóhsan  
           'shed'  
       b. tóhsán-ək  
           shed-LOC  
           'shed (loc.)'
- (20) a. píhtin-ákwem  
           hand-stick  
           'arm (excluding the hand)'  
       b. h-píhtin-ákwém-əl  
           3-hand-stick-33IN  
           'his arms'
- (21) a. él-ápi-t  
           thus-look-3AN  
           'the way he looks (at something)'  
       b. él-apí-mək  
           thus-look-UNSPEC  
           'when they (unspecified) look there'

A /ə/ which is stressable because it is the last vowel of a word will be treated as unstressable when a suffix containing a vowel is added. Schwa counts for stress placement, for example, in the last syllable of táli-kən (ongoing-grow-(3)) 'it is growing'; but the corresponding vowel is skipped over in stress assignment in táli-kən-əl (ongoing-grow-(3)-33IN) 'they (in.) are growing.'

The underlined schwas in (22) do not occupy any of the environments in (18), and all are skipped over by the Alternating

Stress Rule. In (a)-(c) the result is primary stress on the antepenultimate syllable of the word. In (d), secondary stress is retracted one syllable further than we would expect on the basis of a simple alternating pattern.

- (22) a. sók-əlan  
 pour-rain-(3)  
 'it pours (rain)'
- b. wícohké-t-əm-ən  
 (3)-help-TI-TI-3IN  
 'he helps it'
- c. pét-ék-əpo  
 arrive-sheetlike-sit-(3)  
 'it (an., e.g. cloth) comes to be located here'
- d. kís-ámik-ətákkó  
 past-up-jump-(3)  
 'he jumped up'

In (23), the corresponding schwas follow clusters of non-syllabics which are not of the form /hC/. Here these schwas are taken into account in assigning stress, so that we have main stress on the penult in (a)-(c) and secondary stress on the second syllable before the primary stress in (d).

- (23) a. písk-əlan  
 dark-rain-(3)  
 'it rains so hard that it is dark or hard to see'
- b. mǝsk-əm-ən  
 (3)-find-TI-3IN  
 'he finds it'
- c. sp-əpo  
 above-sit-(3)  
 'he sits up high'
- d. amálh-ətǝkko  
 fancy-jump-(3)

Geminate clusters usually pattern with other clusters in their effects on stressability, so that a following /ə/ is counted in assigning stress:

- (24) a. cǝn-éssən-ol  
 stop-move-(3)-33IN  
 'they (in.) stop'
- b. tékk-əpi-t  
 as.far-sit-3AN  
 'as far away as he sits'
- c. h-kǝpp-ətoné-n-a-l  
 3-close-mouth-by.hand-DIR-3.OBV  
 'he holds the other's mouth shut'

We will see below, however, that unstressable /ə/ is regularly permitted after /ss/ derived from underlying /hs/. There also appear to be some cases in which /ə/ is treated as unstressable

after underlying geminate consonants. Since the clearest examples of this kind involve effects on syncope, the relevant examples are discussed in 5.2.12 and 6.4.4.

After clusters of /h/ and an obstruent, /ə/ may remain unstressable. The underlined schwas in (25) are ignored when stress is assigned by the ASR.

- (25) a. cə́hcələkws  
           'gland'
- b. təkəneps  
           'monkey'
- c. ht-ə́tóhk-əm- 1  
           3-deer-POSS  
           'his deer'
- d. kɪni-hpən-e  
           large-potato-II-(3)  
           'it is a big potato'
- e. mə́skɪ-htəw-e  
           stink-whiskers-AI-(3)  
           'he has smelly whiskers'
- f. átpáhkənikéhsəw-ək  
           inchworm-33PROX  
           'inchworms'

After /hl/, on the other hand, /ə/ is always treated as stressable. Thus we have penultimate stress in (26), where the underlined schwas may not be skipped over in counting syllables.

- (26) a. pəm-éhləkwe  
 along-float-(3)  
 'it floats along'
- b. ác-ehl-əso  
 change-TA-REFLEX-(3)  
 'he changes himself'

The /ə/ of the reflexive suffix /-əsi-/ is basically unstressable: compare kál-so 'he hides himself,' from /kal-əsi-w/ (hide-REFLEX-3), in which this vowel is subject to syncope. In Chapter 7 I will argue that this /ə/ is epenthetic and that epenthetic schwas in general are basically unstressable. There are no examples of /ə/ (underlying or epenthetic) after underlying /hm/, /hn/, or /hy/, which are all quite rare. (These clusters and /hl/ are the only combinations of /h/ and a non-syllabic sonorant which occur in underlying forms.)

Schwa is always stressable when it stands between /s/ and /hs/. This principle has a rather restricted range of application, however, since the only relevant examples involve epenthetic / / before the diminutive suffix /-hs-/ (or the homophonous pejorative suffix). Underlying /hs/ becomes ss after /ə/ by a rule which will be formalized in 4.2.2, so /səhs/ surfaces as səss in all forms to which (18d) is relevant.

The diminutive suffix appears on the surface in its basic form after vowels other than ə, as shown in (27) and (28). Non-diminutive forms with the locative suffix /-k/ are given for comparison.

- (27) a. póhtáya-k  
 bottle-LOC  
 'bottle (loc.)'  
 b. póhtayá-hs-is  
 bottle-DIM-DIM  
 'bottle (dim.)'
- (28) a. pápskǎte-k  
 stove-LOC  
 'stove (loc.)'  
 b. pápskǎté-hs-is  
 stove-DIM-DIM  
 'stove (dim.)'

In productively formed nominal diminutives like those in (27) and (28), both the general diminutive suffix /-hs-/, which also occurs in verb forms, and the nonimal diminutive suffix /-is/ are added to the stem. When the same morphemic material is added to a stem which ends in a consonant other than /s/, an epenthetic ǎ appears before the suffix /-hs-/ just in case this ǎ is in a position where it must be stressable. Thus we find ǎ between stem and suffix in (29b), with ss in the suffix for underlying /hs/. Where epenthetic /ǎ/ remains unstressable, it is subject to syncope, /h/ is lost beteen consonants, and /hs/ surfaces as s, as shown in (30b).

- (29) a. khákaṇ  
           'door'  
       b. khákaṇ-əss-is  
           door-DIM-DIM  
           'door (dim.)'

- (30) a. émkwan  
           'spoon'  
       b. émkwán-s-is  
           spoon-DIM-DIM  
           'spoon (dim.)'

The underlined ə in (29b) is stressable by case (f) of (18), as we will see below.

In diminutive forms of stems ending in /s/, epenthetic /ə/ is always stressable before /-hs-/ and is therefore not subject to syncope. Note the penultimate stress of (31b).

- (31) a. skánis  
           'bone'  
       b. skánis-əss-is  
           bone-DIM-DIM  
           'bone (dim.)'

Schwa is also stressable in all examples of surface səss in which ss is not in alternation with hs: áthosəssəw-əl (snake-3.OBV) 'snake (obv.)'. Since this generalization is not involved in any alternations, however, it is possible to analyze ə as inherently stressable in these cases. While there are no examples of syncope between /s/ and /ss/, we will see in Chapter



5 that /ə/ is sometimes subject to syncope between /s/ and a single /s/, so /ə/ is not necessarily stressable in the latter environment.

#### 4.2.2 H-Deletion I and I-Backing

The change of /hs/ to /ss/ after /ə/ can be analyzed as a process of compensatory lengthening. We need only suppose that the segmental material of /h/ is deleted between /ə/ and /s/, leaving behind an empty position on the CV tier. I call the rule in question H-Deletion I, since it is only one of several rules deleting /h/ which will be formulated in the course of this study.

(32) H-Deletion I

$$h \rightarrow \emptyset / \underline{\text{ə}} \_ s$$

If this rule affects only the segmental tier, then it will make the first of the two changes shown in (33). In 5.7.6 I will demonstrate that there is independent motivation for a rule which links an empty C-slot with segmental material associated with a C-slot on its right. This rule will complete the change from /hs/ to /ss/.

$$(33) \begin{array}{ccc} V & C & C \\ | & | & | \\ \text{ə} & h & s \end{array} \rightarrow \begin{array}{ccc} V & C & C \\ | & | & | \\ \text{ə} & \_ & s \end{array} \rightarrow \begin{array}{ccc} V & C & C \\ | & | & \vee \\ \text{ə} & \_ & s \end{array}$$

H-Deletion I is triggered not only by epenthetic /ə/ but also by the output of a rule which backs /i/ to /ə/ before /hs/:

(34) I-Backing

i ---> ə / \_\_\_ h s

I will illustrate this process with examples in which a consonant-final root adds connective /i/ before one of the finals /-hsin-/ 'lie, come to rest' and /-hsəmi-/ 'drink.'

These finals appear with surface hs after roots ending in /a/ or /e/:

(35) a. kwsə́ká-hsin

across-lie-(3)

'he lies across something'

b. síkté-hsin

to.death-lie-(3)

'he dies in a fall or crash'

(36) a. nákká-hsəmin

(3)-all-drink-PEG

'he drinks all of it'

b. mácé-hsəmo

start-drink-(3)

'he starts drinking'

The roots /al-/ 'around' and /pəm-/ 'along' surface in their basic, consonant-final forms before vowel-initial finals:

- (37) a. á<sup>́</sup>l-asóke  
 around-wade-(3)  
 'he wades around'
- b. p<sup>ə</sup>m-ásóke  
 along-wade-(3)  
 'he wades along'

Before consonant-initial finals like /-ph-/ 'carry,' they add connective /i/.

- (38) a. ht-á<sup>́</sup>l<sup>́</sup>i-ph-a-l  
 3-around-carry-DIR-3.OBV  
 'he carries the other around'
- b. h-p<sup>ə</sup>m<sup>́</sup>i-ph-a-l  
 3-along-carry-DIR-3.OBV  
 'he carries the other along'
- cf. c. má<sup>́</sup>cé-ph-a-l  
 (3)-start-carry-DIR-3.OBV  
 'he takes the other away'

Roots which end in /t/, like /nat-/ 'come, go' and /meht-/ 'stop, finish,' also add /i/ before a consonant; and this /i/ triggers palatalization of the root-final /t/:<sup>5</sup>

- (39) a. nat-əl<sup>́</sup>óhke  
 go-work-(3)  
 'he goes somewhere and works'
- b. ná<sup>́</sup>cí-ph-a-l  
 (3)-go-carry-DIR-3.OBV  
 'he goes somewhere and gets the other'

- (40) a. méht-əlóhke  
 finish-work-(3)  
 'he stops working'
- b. méhcí-kətən  
 finish-year-(3)  
 'the year ends'

When /al-/, /pəm-/, /nat-/, or /meht-/ is combined with /-hsin-/ or /-hsəmi-/, connective /i/ is inserted, but /ihs/ surfaces as əss:

- (41) a. álə-ssin  
 around-lie-(3)  
 'he lies around'
- b. pəmá-ssin  
 along-lie-(3)  
 'he is lying down'
- c. nacá-ssin  
 go-lie-(3)  
 'he goes somewhere and lies down'
- d. méhcá-ssəmo  
 finish-drink-(3)  
 'he stops drinking'

The fact that root-final /t/ shows up as c in (41c) and (41d) confirms that connective /i/ is the source of the following ə in these examples. The change of /i/ to /ə/ is accounted for by I-Backing. H-Deletion I is responsible for the realization of /əhs/ as əss.

Schwas derived by I-Backing are always stressable, whether or not they fall into one of the categories listed in (18). The role of these vowels in stress assignment is presumably to be attributed to the fact that all occurrences of /i/ which undergo I-Backing are stressable.

#### 4.2.3 Word-initial /((C)ə [+sonorant]ə /

We come now to clause (e) of (18), which requires the first /ə/ in word-initial /((C)ə [+sonorant]ə/ to be counted for stress placement when the second /ə/ in this configuration is unstressable. The effects of this provision can be seen in (42), where ə in the first syllable of each word is stressed and ə in the second syllable has been skipped over in counting syllables for the assignment of alternating stress.

- (42) a. ə́ləmoss  
           'dog'  
       b. ə́lənahkw  
           'iron'  
       c. mənəkwan  
           'rainbow'  
       d. nə́ləmək  
           'upriver'

Compare mənihkw 'island,' where ə is unstressable in a word-initial syllable but the next vowel of the word is stressable.

The same point can be made by considering the treatment which roots like /kəl-/ 'hold fast,' /wəl-/ 'good,' and /pəm-/ 'along' receive in stress assignment. The schwas of these roots are underlyingly unstressable. Thus, for example, the ə of pəm- remains unstressed in pəm-áwso (along-live-(3)) 'he is alive' or pəmí-ph-â (along-carry-3PASS) 'he is carried along.' Schwa is available for stress assignment in these roots, however, when the following morpheme begins with an unstressable /ə/:

- (43) a. kəl-əco  
 hold-cold-(3)  
 'he freezes'
- b. kəl-ətən  
 hold-cold-(3)  
 'it freezes'
- (44) a. wəl-əpo  
 good-sit-(3)  
 'he sits nicely, comfortably; he is well off'
- b. wəl-əwe  
 good-hair-(3)  
 'he has nice hair, fur'
- (45) a. pəm-əka  
 along-dance-(3)  
 'he dances'
- b. pəm-əkohóke  
 along-float-(3)  
 'he floats along (in a current)'

A root which begins with a sequence which meets the requirements of (18e) will always be stressed on its initial syllable:

(46) a. álám-apása-w-ək  
 away-pl.walk-3-33PROX  
 'they (pl.) walk away'

b. álami-təwíye  
 away-fly-(3)  
 'he flies away'

(47) a. álək-w-ewésto  
 direction-speak-(3)  
 'he speaks in that direction; he walks in that direction while speaking'

b. áləkwi-təwíye  
 direction-fly-(3)  
 'he flies in that direction'

When the second /ə/ in word-initial /(C) ə [+sonorant] ə / is inherently stressable, (18e) is not applicable and the first /ə/ in the sequence is free to be unstressable. Thus the word álək-w-ə-təwákən 'article of clothing,' in which the second /ə/ is ordinarily unstressable, has a by-form álək-w-ə-təwákən, in which the second /ə/ is inherently stressable. The result of this idiosyncrasy is that the first and third schwa\_s in this alternate form remain unstressable and are subject to syncope. (Compare the possessed forms ht-álək-w-ə-təwákən-əl and ht-álək-w-ə-təwákən-əl 'his clothes,' which show that both alternates

of the stem begin with underlying /ə/.) The first /ə/ of words like pəmə́-ssin 'he is lying down' (from /pə mi-hsin-w/- along-lie-3) and cəmə́-ssəmo 'he stops drinking' (from /cəni-hsəmi-w/ stop-drink-3) likewise remain unstressable, since the second /ə/ in each of these words is derived by I-Backing and is therefore inherently stressable.

The first /ə/ in word-initial /(C)ə Cə/ is also free to be unstressable when the second C in the configuration is an obstruent. In such cases, however, unstressable /ə/ is regularly subject to syncope: underlying /kətək-wəni-w/ (over-AI-(3)) yields ktək-wəno 'he stays over (in a place)' (cf. n-kətək-wən 'I stay over').

An apparent counterexample to principle (18e) as it is stated is the objectless TI form nən-əm (know-TI-(3)) 'he knows a lot.' Since the /ə/ of the TI formative /-əm-/ is the last vowel here in underlying /nən-əm-w/, it is stressable by (18a). We might then expect the /ə/ of /nən-/ 'know' to be unstressable, giving us \*nən-əm. Unfortunately, however, there are no other forms in which /nən-/ might be expected to surface with unstressable ə. There is accordingly nothing to bar us from setting up inherently stressable /ə/ in this morpheme, which would allow us to derive the observed stress pattern for nən-əm without reference to principle (18e). Thus it is not in fact clear that the stress pattern of nən-əm bears on the correct formulation of (18e). I know of no other forms in which there is a potential interaction between (18a) and (18e).



#### 4.2.4 Alternating stressability

When no other condition which determines stressability takes precedence, stressable and unstressable schwas are distributed in an alternating pattern: counting from left to right, odd-numbered schwas are unstressable and even-numbered schwas are stressable in a series if /C<sub>0</sub>ə/ sequences which is chosen to be as long as possible without including any /ə/ which falls under (18a-e) or is inherently stressable.

In (48), each of the underlined schwas occurs in a one-vowel span which satisfies these conditions. Since each of these schwas is in an odd-numbered position in this span (the first of one), it is skipped over in stress assignment and the forms receive antepenultimate stress.

- (48) a. h-péhk-ə́n-a-l  
 3-completely-by.hand-DIR-3.OBV  
 'he takes all of it (an.); he takes everything  
 from the other'
- b. k'is-ə́lan  
 past-rain-(3)  
 'it rained'
- c. sítam-ək  
 shore-LOC  
 'shore (loc.)'
- d. épahsí-kə́tan  
 half-year-(3)  
 'it is half a year'
- e. ápock-əl-ə́po  
 upside.down-sit-(3)  
 'he is upside down'

There is only one /ə́/ in (48a,b). Since this vowel is not in a word-final syllable, follows a single consonant, and does not stand between /s/ and /hs/, it is free to be unstressable. In (48c) there are two schwas, but the second is the last vowel of the word, so it falls under (18a) and is stressable regardless of its status with respect to alternating stressability. The situation in (48d) is similar. In (48e) there are again two schwas, but here the first is excluded from consideration under the principle of alternating stressability because it follows the cluster /ck/.

The underlined schwas in (49) are also free to be unstressable, those in (a) and (b) because they follow a single consonant, those in (c) and (d) because they follow a cluster of /h/ and an obstruent. In the first of these examples, secondary stress occurs on the second syllable preceding the primary stress because the underlined schwas are ignored by the ASR. In (49d), secondary stress is retracted over two extra syllables by skipping two unstressable schwas in the syllable count.

- (49) a. ní-sék-əpí-si-t  
 two-sheetlike-sit-AI-3AN  
 'ghost'  
 ("that which is two layers of cloth"?)
- b. nákkahsəw-éhto-n  
 (3)-extinguish-TI-3IN  
 'he puts it (light, fire) out'
- c. méht-ən-askí-ye  
 finish-by.hand(?)-event(?)-go-(3)  
 'it is all over'
- d. ákənotəmá-kən  
 tell.story-NOM  
 'story'

In a series of two schwas, neither of which is obligatorily stressable on other grounds, the first is unstressable and the second is stressable. Thus the second of the underlined schwas receives stress in each of the following examples, and the first of the underlined schwas in (50c) is not counted by the ASR in assigning secondary stress.

- (50) a. kínəw-əso  
 particular-AI-(3)  
 'he is a certain one'
- b. h-péhk-ən-əm-ən  
 3-completely-by.hand-TI-3IN  
 'he takes it all'
- c. tətəm-ask-ówi-kətán-e  
 equal-event(?)-II-year-AI-(3)  
 'his birthday falls on the day of the week  
 on which he was born'

The examples in (51) show that /ə/ is not inherently stressable in /əlohk-/ 'work, do' and /əkehki-/ 'teach,' since the underlined vowels in these examples are ignored in assigning alternating stress.

- (51) a. nís-əlohk-ám-a-l  
 (3)-two-work-TA-DIR-3.OBV  
 'he works with the other'
- b. nát-əkehki-m-a-l  
 (3)-go-teach-TA-DIR-3.OBV  
 'he goes somewhere and teaches the other'

The /ə/ of each of these morphemes counts as stressable, however, when it is the second of two schwas that fall under (18f):

- (52) a. étəl-əlóhk-é-c-ik  
 ongoing-work-AI-3AN-33PROX  
 'they (du.) who are working'
- b. íhtəl-əkehki'-m-ot  
 usually-teach-TA-3PASS  
 'where he goes to school'

Of course whether or not a stressable /ə/ actually receives stress depends on its position in the right-to-left syllable count. In (53a,b) the second underlined ə is in a stressable position within its series of schwas, but it is not stressed because it is in an odd-numbered syllable, counting from the end of the word.

- (53) a. étəl-əlóhk-e-t  
 ongoing-work-AI-3AN  
 'he who is working'
- b. íhtəl-əkehki-tí'-mæk  
 usually-teach-RECIP-UNSPEC  
 'where school is held'

In a series of three schwas that satisfies the conditions for alternating stressability, the first and third are unstressable and the second is stressable. Thus the second of the underlined schwas receives stress by the ASR in (54a) and the three underlined schwas in (54b) have the value of one syllable for alternating stress assignment.

- (54). a. kinəw-əsə-w-ək  
 particular-AI-3-33PROX  
 'they (du.) are certain ones'
- b. ásəw-əcək-áhte  
 ~ áhsəw-əcək-áhte  
 oblique-messy-be.located-(3)  
 'it is flopped over to one side'

While the variation between s and hs in (54b) has no effect on the position of stress, the cluster sk in (55a-c) makes the following ə stressable in each of these forms. This ə is excluded from the series within which alternating stressability holds, so that stressability is determined by even and odd position among the underlined schwas.

- (55) a. h-pásk-ən-əm-ən  
 3-break-by.hand-TI-3IN  
 'he breaks it with his hand'
- b. k-pásk-ə cək-ən-a  
 2-break-messy-by.hand-DIR  
 'you (sg.) break ním, it (an., squishy)  
 with your hand'
- c. h-pásk-əcək-ən-əm- n  
 3-break-messy-by.hand-TI-3IN  
 'he breaks it (squishy) with his hand'

These examples may be compared with (48a) and (50b), where the /ə/ of /-ən-/ 'by hand' is treated as unstressable.

The examples in (56) are similar to those in (55), except that here the first of a series of schwas must be excluded from participating in alternating stressability not because it follows a cluster but because it is the first /ə/ in word-initial /((C) ə [+sonorant] ə/ and is therefore stressable by (18e). The alternating pattern of stressability holds among the underlined schwas in (56a,b).

(56) a. ələkwətewəkən-əl

clothing-33IN

'articles of clothing'

b. təhpo... kwəni                      əl-ən-əm-əw-a-t

only            at.that.point thus-by.hand-TI-TA-DIR-3AN

'he just handed it to the other (e.g. without being asked)'

Two forms in which alternating stressability can be observed in a series if four schwas are given in (57). There are relatively few examples like these in which all of the vowels surface in a long series of schwas within which alternating stressability holds. More frequently, one or more of the unstressable schwas is subject to syncope.

(57) a. əsəw-əcək-əpo

oblique-messy-sit-(3)

'it (an.) is flopped over to one side'

b. ht-ətəl-ət-əm-ən-əl

3-ongoing-eat-TI-3IN-33IN

'he is eating them (in.)'

The first of these examples is straightforward, but (57b) requires some commentary. The third person prefix, underlyingly /w-/ ~ /wt-/, is subject to Initial Devoicing. This rule has the effect of converting word-initial /wt/ to /ht/ in (57b). While word-internal /hC/ is equivalent to a single consonant in its effects on stressability, the clusters which surface as hC as the result of the application of Initial Devoicing pattern with non-laryngeal clusters in this respect, so that a following /ə/ is treated as stressable. Thus the first /ə/ of htátalətamánəl is stressable by virtue of the preceding cluster and is excluded from the series of schwas within which alternating stressability is figured.

Utterance-initial /w/ is always devoiced before a voiceless consonant, but Initial Devoicing is not always applied where /w/ at the beginning of a word can be syllabified with a preceding vowel:

(58) ksé-he	náka	{	wt-ápi-n.
			ht-əpi-n.
in-go-(3) and			3-sit-SUBORD
'He comes in and sits down.'			

As (58) illustrates, /ə/ is stressable after the third person prefix whether or not Initial Devoicing is applied.

The /w/ of the prefix is not subject to Initial Devoicing before a non-syllabic sonorant, but in this environment a second rule is applicable which may delete this /w/ altogether. Like



Initial Devoicing, this rule is not always applied where /w/ may be syllabified with a preceding vowel:

- (59) má te { w-nán-əw-á-wi-yil.  
 nán-əw-á-wi-yil.  
 not EMPH 3-know-TA-DIR-NEG-3.OBV  
 'He does not know the other.'

Here again the /w/ of the prefix forms a cluster with the initial segment of the stem after which /ə/ must be treated as stressable, whether or not this segment is retained on the surface. Thus the /ə/ of /məs-/ 'get' is stressed in both (60a) and (60b) and is not included with the underlined schwas in figuring alternating stressability in either case. (The /ə/ of this morpheme cannot be inherently stressable, however, since it is subject to syncope in forms like máke ms-ə́n-ə́m-ə́n ((3)-much get-by.hand-TI-3IN) 'he gets a lot of it.')

- (60) a. mécimí te w-má's-ə́n-ə́m-ə́n.  
 always EMPH 3get-by.hand-TI-3IN  
 'He always gets it.'  
 b. má's-ə́n-ə́m-ə́n  
 (3)-get-by.hand-TI-3IN  
 'he gets it'

Both Initial Devoicing and the rule which deletes /w/ in (59) and (60) are discussed in detail in 5.3.

Now the patterns of alternating stressability which we just surveyed are highly reminiscent of patterns of alternating

stress. It seems more than likely that the distribution of stressable and unstressable vowels in Passamaquoddy reflects the stress rules of an earlier stage in the history of the language, and that the current Initial Stress Rule and Alternating Stress Rule represent a process of stress assignment which has been imposed on the output of this earlier system. The choice between the metrical and CV theories of the stressable/distinction which will be our central concern in much of the rest of this work is essentially a matter of deciding how much of this historical course of events continues to be reflected in the procedures for the construction of metrical structures which form part of the synchronic grammar of Passamaquoddy. In particular, does the persistence of alternating patterns of stressability indicate that a process which assigns metrical structure from left to right continues to operate in the contemporary language, in addition to the right-to-left process represented by the Alternating Stress Rule?

It may also be appropriate here to raise a second question concerning the relationship between the historical origins of the conditions on stressability and their implementation in a synchronic analysis. I noted above that unstressable schwas are regularly subject to syncope in certain environments. The deletion of the /ə/ of /məs-/ 'get' in máke mə-ə́n-ə́m-ə́n 'he gets a lot of it' is a typical example. The /ə/ of /-ə́n-/ 'by hand' is stressable in this form because it is the second /ə/ in underlying /məs-ə́n-ə́m-/. But note that this vowel also follows the cluster /ms/ in the output of syncope. We might wonder, then, whether we could reduce the apparent effects of clusters on

stressability to the effects of alternating stressability by deriving all of the clusters after which /ə/ must be treated as stressable from underlying sequences of the form /CəC/. (Such a reduction is in fact assumed by Sherwood (1983b:32), who does not recognize any autonomous cluster effects.)

It seems entirely possible that the synchronic principles which make /ə/ stressable after clusters have their historical origins in the derivation of clusters through vowel deletion. Consider, for example, the word éspəns-əl (raccoon-3.OBV) 'raccoon (obv.).' Here we find a stressable ə after the cluster sp. But sp in this word reflects earlier \*səp: compare Penobscot ésəpanəss 'raccoon' (Siebert 1967:21). Before \*ə was lost in this word, there would have been no need to appeal to cluster effects to account for the distribution of stressable and unstressable vowels in the ancestor of éspənsəl.

In contemporary Passamaquoddy, however, the cluster sp never alternates with səp in any form of éspəns 'raccoon.' Many other morphemes also contain non-alternating clusters after which /ə/ is always treated as stressable. Morphemes of this kind which may be found in the examples cited above include pisk- 'dark,' -məsk- 'find,' sp- 'above,' and aməlh- 'fancy' in (23), tekk- 'as far,' and kəpp- 'close' in (24), the TA final -əhl- in (26), and pəsk- 'break' in (55). All of these morphemes may be followed by occurrences of /ə/ which are demonstrably not inherently stressable, so that their effects on stressability result in clear surface alternations. Evidence will be presented in 5.4 which demonstrates that there are many cases in which derivations of clusters with comparable effects on stressability are not only

unmotivated but actually inconsistent with the conditions which otherwise govern syncope in the contemporary language.

#### 4.2.5 Inherently stressable /ə/

The distribution of stressable and unstressable /ə/ is not fully predictable. Certain occurrences of /ə/ are inherently stressable: they are available to the stress rules even in environments in which other schwas would be invisible. The first /ə/ of əpasi-k 'tree, stick (loc.)', for example, is stressable, although a similarly situated /ə/ in pəsanòt 'basket' (underlying /əpəsanote/) is unstressable and subject to syncope. (Compare ht-əpəsanòt (3-basket) 'his basket.')

By contrast, there appear to be virtually no cases of irregularly unstressable /ə/, /ə/ which is not available to the stress rules even though it occurs in an environment in which this vowel is otherwise treated as stressable.<sup>6</sup>

Inherently stressable /ə/ is quite common in initial syllables, as in the following examples:

- (61) a. tá-k-e  
 hit-AI-(3)  
 'he hits'
- b. kwəcám-ək  
 outdoors-LOC  
 'outdoors'
- c. kətáwi-táwíye  
 want-fly-(3)  
 'he wants to fly'
- d. məte-hté-hsin  
 be.heard-strike-lie-(3)  
 'he is heard to fall with a crash'
- e. mətapé-hte  
 downhill-be.located-(3)  
 'it is situated facing downhill'
- f. məkásew-álohkí-ye  
 black-cloud-go-(3)  
 'there are black clouds'

Schwa is unstressable in comparable environments in other words. For example, the ə of také 'now' is unstressable, so that this word receives final stress rather than the penultimate stress that we find in tá-k-e 'he hits.' Unstressable /ə/ is usually subject to syncope before obstruents, however, so that forms like these in which there is a surface contrast between stressable and unstressable ə before an obstruent under identical segmental conditions are quite rare. (The ə of také 'now' is a synchronic

exception to syncope.) See 5.2.6 for further discussion of this point.

Inherently stressable /ə/ is found in non-initial syllables in the examples given in (62). (Both shəwə are inherently stressable in the forms in (62b).)

- (62) a. áhsəsəwən  
       ~ áhsosəwən  
       'hat'
- b. nəmihkwəso  
    ~ mə.ihkwəso  
       be.born-(3)  
       'he is born'

The first /ə/ of /-hpənəsi-/ 'fight' is optionally treated as inherently stressable, with the result that we may have either penultimate stress or antepenultimate stress in (63). (Alternating stressability makes the second /ə/ of /-hpənəsi-/ stressable in the second of these forms.)

- (63) máce-hpənəsó  
       ~ máce-hpənəsó  
       start-fight-(3)  
       'he starts to fight'

Like other stressable schwas, inherently stressable schwas are not necessarily stressed: the underlined vowel in (64) enters into the syllable count which determines how stress is assigned, but does not itself receive stress.

(64) étóci námíhkwəsi-t-pən  
 extreme be.born-3AN-PRET  
 'when he was born'

Like schwas which are stressable under clauses (a)-(e) of (18), inherently stressable schwas are excluded from consideration in determining alternating stressability. The third ə of ták-am-əso (hit-TA-REFLEX-(3)) 'he hits himself' is stressable rather than the second because the ə of tək- 'hit' is inherently stressable.

For the most part, if /ə/ is inherently stressable in one occurrence of a morpheme, it is inherently stressable in all of its occurrences. Thus the /ə/ of /tək-/ is inherently stressable not only in ták-e 'he hits' and ták-am-əso 'he hits himself' but also in ták-ət-am (hit-TI-TI-(3)) 'he hits, he bats (in baseball)' and in nóci ták-ətí-ke-t (occupation hit-TI-AI-3AN) 'boxer.' Not surprisingly, there are some irregularities. The first /ə/ of /əpəsi-/ 'warm' appears to be inherently stressable and the second unstressable in əpəso (warm-(3)) 'he has a fever,' but the first /ə/ of this morpheme is unstressable and the second (predictably) stressable in wəl-əpəso (good-warm-(3)) 'he is nice and warm.' Schwa is inherently stressable in the initial syllables of kətək-ik (other-33PROX) 'others (an.)' and kətək-il (other-33IN) 'others (in.),' but not in the first syllable of kətək 'other (an. or in.).'

There are certain regularities in the distribution of inherently stressable /ə/. Unpredictably stressable /ə/ is common before obstruents, for example, but rare before sonorants. Schwa is always stressable in forms like əptan '(a woman's) coat'

where it precedes an underlying cluster other than /sC/ or a geminate. No alternations are based on this generalization, however, so it seems best to analyze all such occurrences of /ə/ as underlyingly stressable.

We might also choose to analyze /ə/ as inherently stressable when its position within a morpheme guarantees that it will always fall under one of the generalizations of (18). The /ə/ of /apockəl-/ 'upside down,' for example, will always be treated as stressable, since it follows the cluster /ck/. (Of course this /ə/ can be unstressed as it is in ápockəl-éssó (upside.down-move-(3)) 'he falls over.'). The morphology of Passamaquoddy provides no circumstances under which the second /ə/ of /-kətən-/ 'year' is not either the last vowel of a word (épahsi-kətən (half-year-(3)) 'it is half a year') or in a position to be stressable by alternating stressability (nísi-kətən-e (two-year-AI-(3)) 'he is two years old'). There would seem to be no empirical consequences to the claim that vowels like these are underlyingly unstressable and become stressable through the application of one or another rule.

Pervasive and continuing processes of paradigm leveling seem, in fact, to involve taking more and more occurrences of /ə/ to be inherently stressable. Consider, for example, the root /ətəl-/ 'ongoing,' whose first /ə/ is stressable after a personal prefix (ht-ətəlí-na-n (ongoing-die-SUBORD) 'he is dying (Subordinative)') but unstressable and subject to syncope in unprefixated forms (təlí-ne (ongoing-die-(3)) 'he is dying'). Recutting of the prefixed forms has led to the creation of a new root /tətəl-/ whose shape is invariant in the prefixing modes.



The first /ə/ of this root is inherently stressable: tátali-ne (ongoing-die-(3)) 'he is dying,' tátal-ətémó (ongoing-cry-(3)) 'he is crying.'

#### 4.3 Stressability as a diacritic feature

In his discussion of Delaware morphophonemics, Goddard distinguishes between "weak" and "strong" vowels as follows:

Every vowel is labeled as either weak (<sup>WK</sup>) or strong (<sup>ST</sup>). Automatically <sup>VST</sup> are long vowels and vowels before consonant clusters... In a sequence of one or more syllables each of which contains a short vowel followed by a C or a combination Cw, the odd numbered vowels are <sup>VWK</sup> and the even numbered <sup>VST</sup>. Irregularly some short vowels are <sup>VST</sup> even though in a weakening environment... (1969:21)

He then states the basic principle which determines the location of (primary) stress in the following terms:

The last nonultimate <sup>VST</sup> is stressed (or a final-syllable <sup>VST</sup> if it is the only one in the word)... (1969:21)

The distinction between weak and strong vowels figures in his formulation of various other morphophonemic processes as well, including several rules of syncope.

The stressable/unstressable distinction of Passamaquoddy and the strong/weak distinction of Delaware are clearly based on similar principles. In both languages, particular vowels are unpredictably strong. A principle of alternating strength holds in a similar range of cases. Not all of the details of the two systems match, however. For example, in Passamaquoddy /ə/ is not obligatorily stressable before all types of clusters. (In

Chapter 6 we will see that underlyingly unstressable /i/, /a/, and /o/ are found only before certain consonant clusters.)

Sherwood (1983:32-35) has proposed an analysis of Maliseet syncope in which he distinguishes two underlying "short" vowels, /ǎ/ and /ə/, and four underlying "long" vowels, /i/, /e/, /o/, and /a/. "Weak" and "strong" occurrences of /ǎ/ and /ə/ are determined by a version of the principle of alternating stressability.

While his inventory of underlying segments allows Sherwood to set up underlying representations which are similar to those which Goddard has proposed for Delaware, both his morphophoneme /ǎ/ and the distinction between short and long vowels which he employs are wholly abstract in Maliseet. Short /ǎ/ always either undergoes syncope or merges with /ə/ or /a/ in surface forms. There is no correlation between underlying length and the highly restricted surface length distinctions of the language.<sup>7</sup> Because he does not recognize any of the determinants of stressability apart from a principle of weak and strong positions, Sherwood's proposal is in any case not sufficiently articulated to permit an account of the full range of facts of stress.

The purpose of the present section is to develop a formal account of the stressable/unstressable distinction along the lines which Goddard has suggested that is at once sufficiently concrete to be plausible and sufficiently detailed to permit comparison with the proposals which are developed in the following two sections. I will consider more of the particulars of Sherwood's analysis of syncope in Chapters 5 and 6.

As a point of departure for the discussion which follows, I will take it as given that the underlying vowels of Passamaquoddy are /i e o a ə/ and that vowel length is not distinctive in underlying representations. The idea that vowels are labeled as weak or strong can then be formalized by introducing a diacritic feature [strong].<sup>8</sup>

We may assume for present purposes that underlying /i e o a/ are always specified as [+st<sup>o</sup>ng] in lexical entries, perhaps by a lexical redundancy rule. (The underlying occurrences of unstressable /i o a/ which will be introduced in Chapters 6 and 8 may be viewed as exceptions to this lexical redundancy rule.) Underlying /ə/ may be lexically specified either as [+strong] or as [-strong]. Schwas which are underlyingly [+strong] are inherently stressable. Schwas which are underlyingly [-strong] may surface as unstressable vowels, may undergo syncope, or may become [+strong] in the course of phonological derivations.

On these assumptions, all of the vowels in a word like póhtáya-k 'bottle (loc.),' píhtin-áhk<sup>w</sup>em 'arm,' or téhsáhk<sup>w</sup>-apás-oltí-ne 'let's (pl.) walk around on top' will be [+strong]. The schwas in words like m<sup>a</sup>níhk<sup>w</sup> 'island,' sók-əlan 'it pours (rain),' and nís-ek-əpí-si-t 'ghost' will be [-strong], while the inherently stressable schwas of words like námíhk<sup>w</sup>áso 'he is born' will be [+strong]. For these cases, all that we need to do to insure that stress assignment proceeds correctly is to write our stress rules so that they look only at [+strong] vowels:

(65) Stress rules (diacritic version)

- i) ISR: Stress the first [+strong] vowel in a word.
- ii) ASR: Stress every other [+strong] vowel in word, beginning with the penultimate [+strong] vowel and working from right to left.

To incorporate these rules into a grid-based account of stress like that presented in section 1, we can interpret (i) and (ii) as rules for aligning particular demibeats with beats on the second metrical level.

To make this approach work in general, however, it is necessary to postulate phonological rules which will change the strength specification of any underlyingly [-strong] vowel to [+strong] in the environments listed in (18), since all of the generalizations given there correspond to observable alternations in the behavior of particular morphemes with respect to stress assignment. Thus, for example, the [-strong] specification of the /ə/ of /-əlan-/ 'rain' (which is required by sók-əlan 'it pours' and kís-əlan 'it rained') must be changed to [+strong] when this vowel follows a consonant cluster if we are to account for the penultimate stress of písk-əlan 'it rains so hard that it is dark or hard to see' or étót-əpsk-əla-k 'it rains very big drops.'

The need for a rule changing [-strong] to [+strong] is not as apparent in the case of (18a) as it is for (18b-f), since it

is not immediately obvious that a /ə/ in the last syllable of a word must be made stressable prior to stress assignment. Consider, for example, the word kísi-kən (finish-grow-(3)) 'it is full-grown, mature.' The /ə/ of the II final /-kən-/ 'be or become of a kind or nature, grow' must be underlyingly [-strong], since it is skipped over by stress assignment in forms like táíí-kən-ol (ongoing-grow-(3)-33IN) 'they (in.) are growing.' As far as the assignment of the rightmost stress in a word is concerned, however, we will achieve the correct results in stress placement regardless of the status of final syllables if we adopt a formulation of our stress rule like the one quoted above from Goddard's description of Delaware: the last nonultimate [+strong] vowel is stressed or a final-syllable [+strong] vowel if it is the only one in a word. On this account, the rightmost stress will fall on the second syllable of kísi-kən whether or not the /ə/ of /-kən-/ is made [+strong].

When we take the distribution of secondary stress into account, however, it is clear that stress in fact falls on every other stressable vowel from the end of the word. A formulation of stress assignment in Passamaquoddy in terms of the last nonultimate strong vowel simply shifts reference to the final syllable of the word from the conditions on the values of the feature [strong] into the statement of the stress rule itself. Thus the ASR receives a simpler statement if we postulate a rule which makes a [-strong] vowel [+strong] if it is the last vowel of a word:

(66) V ---> [+strong] / \_\_\_ C<sub>0</sub> #

We will see in Chapter 5 that the facts of syncope confirm the need for some operation with the effect of (66): while syncope is permitted in positions where /ə/ may remain unstressable, /ə/ is regularly exempt from syncope where it is the last vowel of a word.

The full set of rules which will be needed to make underlyingly weak /ə/ strong in cases (a)-(f) of (18) is given in (67).

(67) V → [+strong]/

a. \_\_\_ C<sub>0</sub> #

b.            C            C \_\_\_  
              |  
             [-laryngeal]

c. h l \_\_\_

d. s \_\_\_ h s

e. # (C) \_\_\_ [+sonorant] [-strong]

f. [-strong] C \_\_\_ (left-to-right iterative)

Case (a), as we have seen, will make the /ə/ of /-kən-/ 'grow' [+strong] in kísí-kən 'it is full grown.' Case (b) will make underlyingly [-strong] /ə/ [+strong] in písk-əlán 'it rains so hard etc.' Case (c) will make epenthetic /ə/ [+strong] in ác-ehl-əso 'he changes himself' and case (d) will likewise make epenthetic /ə/ [+strong] in skənís-əss-is 'bone (dim.)' Case (e) accounts for stressable /ə/ in the first syllable of pəm-əka 'he dances' and other words which begin with

/((C)ə [+sonorant]ə/. Finally, (f) accounts for cases in which [-strong] /ə/ becomes [+strong] through alternating stressability, as does the /ə/ of /əpi-/ 'sit' in ásəw-əcək-épo 'it (an.) is flopped over to one side.'

At least (67b) and (67e) must be applied before the first applications of (67f), since /ə/ following a cluster other than /hC/ and the first /ə/ in word-initial /((C)ə [+sonorant]ə/ must be excluded from any series of schwas within which alternating stressability is to be calculated: the first /ə/ in pásk-əcək-én-a-l 'he breaks the other (squishy) with his hand' or ələkʷətewakən 'article of clothing' does not figure into alternating stressability. The order of application of (67a) and (67f) does not matter, however. Whichever rule applies first can be allowed to make the last /ə/ stressable in forms like sítəm-ək 'shore (loc.).'

Clearly it is possible to describe the facts set forth in section 2 in terms of a theory which uses a diacritic feature to distinguish between vowels which are available to the stress rules and vowels which are not. Nonetheless, this account has a number of properties which make it clearly unsatisfactory.

First of all there is simply the fact that this approach makes use of a diacritic feature. Any account which would instead refer to some independently motivated phonological property which all stressable or all unstressable vowels have in common would clearly be preferable, particularly if it could be shown that the behavior of this class of vowels in stress assignment follows from this phonological property.

Second, we have been led to assign a value of the feature [strong] to every vowel in every word in the language. Any attempt to restrict the expressive power of grammars by articulating a theory of the evaluation metric should surely attach a high cost to the use of diacritic features. Otherwise there are essentially no limits to the types of phonological patterning which can be called regular. On these grounds, the solution to the problem of the Passamaquoddy stress system that I have sketched in this section should be very costly indeed.

Next, we note that six different phonological rules change the value of the feature [strong] in the various phonological contexts listed in (67). Perhaps by using alpha variables or angled brackets we could collapse (67b) and (67c), the rule for clusters other than /hC/ and the special rule for /hl/. Presumably with enough angled brackets we could collapse one or another of the other possible pairs of rules. The fact remains, however, that we are manipulating an arbitrary feature in a diverse set of contexts. In two cases, (67e) and (67f), the feature [strong] is also used to specify the environment of a rule. Once we permit ourselves to manipulate diacritics in terms of diacritics, we have pretty much abandoned any attempt at limiting the class of phonological systems.

Finally, the form of the individual rules in (67) must be regarded as arbitrary as long as their structural change consists only in altering the value of a diacritic feature. Why should /ə/ count in stress placement because it is the last vowel of a word? Why should /ə/ be stressable after two consonants, rather than only after three? Why is /ə/ always stressable after /hl/



but not after /hk/? Not every aspect of the phonology of a language necessarily has a basis in phonological substance, but an analysis of the stressable/unstressable distinction as a diacritic property necessarily rules out in advance any possibility of finding a phonological explanation for the observed distribution of stressable and unstressable vowels.

#### 4.4 A metrical theory of stressability

Two characteristics of the principle of alternating stressability make a metrical analysis of at least this part of the distribution of stressable and unstressable /ə/ look promising: the principle clearly reflects a process in which some procedure is repeated while the word is scanned from left to right, and this procedure appears to involve gathering up vowels in pairs. Both iterative application and syllable-counting are common features of metrical rules. As part of a general program to restrict the expressive power of grammars, we will undoubtedly want to restrict the class of rules which may share these properties. Thus a demonstration that stressability in Passamaquoddy is best analyzed as a metrical property would certainly be welcome.

Nancy Chinchor and I worked out a preliminary metrical analysis of alternating stressability in 1978. Stowell (1979) then reworked our account and developed it further within a general theory of stress rules. More recently, Halle and Vergnaud (1984) have adapted Stowell's proposals within a different framework for the analysis of stress.

None of these accounts recognizes any of the determinants of stressability except the principle of alternating stressable and unstressable schwas, since the other generalizations in this domain had not yet come to my attention in 1979. Moreover, all of them make certain assumptions about the underlying forms of Passamaquoddy words which I now believe must be abandoned. For example, Stowell (1979:61) writes ə for unstressable i in the second syllable of mə́tiyakwásəkəníke 'he is heard walking in brush,' reflecting our hypothesis about the source of this vowel; but it now appears neither necessary nor desirable to derive unstressable i from /ə/. (See Chapter 8 for discussion.) The assumption that the personal prefixes n-, k-, and w- are underlying /nə-/, /kə-/, and /wə-/ is crucial to his account; but it now seems clear that there are no schwas in the underlying forms of these morphemes. (See 5.4.)

In this section I will develop a metrical theory of the stressable/unstressable distinction which covers the same range of facts as the diacritic account set out in the preceding section and is consistent with what is now known about other aspects of Passamaquoddy phonology. I will argue, however, that this approach ultimately fails to provide the insight which it at first appears to offer.

#### 4.4.1 Three layers of metrical structure

Metrical theories of stress assignment have generally postulated two essential "layers" of tree structure or two

corresponding steps in the establishment of metrical grids: a first round of structure assignment establishes the location of stress in a word, while a second round determines stress subordination. The metrical account of stressability works not by designating some vowels as accessible to the stress rules and others as inaccessible, but by postulating an additional round of structure assignment which precedes the other two. It is convenient to discuss this process in terms of the establishment of constituents in metrical structure, rather than attempting a purely grid-based analysis, since both Stowell's proposals and those of Halle and Vernaud assume such structure.

The constituents of the first layer of metrical structure, which I will call "subfeet," will consist either of one syllable or of two (or of one or two vowels, respectively, if we construct our representations over vowel projections).<sup>9</sup> The right-hand (or only) element in each subfoot is designated as the "head" of that subfoot. If we assign subfeet correctly, we can achieve the effects of the stressable/unstressable distinction by having the rules which construct the second level of metrical structure look only at the heads of subfeet -- or, equivalently, by having the rules of the second level look only at subfeet and interpreting prominence assigned to a subfoot as prominence of its head.

Suppose, for example, that the syllables of the word ákanot, mákan 'story' are organized into subfeet as follows. (The head of each metrical constituent is indicated by a vertical line.)

(68)

a kə no tə ma kən

If we now assign metrical prominence to the second and fourth subfeet, counting from the end of the word, we will establish the syllables a and ma as the most prominent syllables in the word. For present purposes, we can represent this second layer of metrical structure in terms of feet:

(69)

a kə no tə ma kən

The relative prominence of feet can then be identified by means of a word-level tree, the third layer of metrical structure.

(70)

a kə no tə ma kən

For the syllables a and ma, the results that we obtain by counting subfeet are the same as those which we achieved before by counting syllables from the end of the word, skipping over the syllables kə and tə in the count because they contain unstressable schwas. Prominence is assigned to the second and sixth syllables in the word in either case.

More levels of metrical prominence are assigned by this method, however, than we have recognized in our earlier descriptions. Four levels of prominence are represented in a structure like (70). The most prominent syllable in this case is ma: the constituent containing this syllable is the head at each metrical level and it is the head of its subfoot. The next most prominent syllable in a: the subfoot which contains this syllable is the head of its foot, and a is the head of this subfoot. Finally, all syllables which are heads of subfeet (all syllables with stressable vowels) are more prominent than syllables which are non-heads (syllables with unstressable vowels). If we interpret all degrees of metrical prominence as degrees of stress, we will say that all stressable vowels bear some degree of stress, while unstressable vowels are unstressed.

This conclusion is not in itself implausible. Unstressable vowels which are not eliminated by phonological syncope are often subject to phonetic reduction or even deletion -- a process which we might call "phonetic syncope." Given a theory in which all and only unstressable vowels are stressless, we can correctly delimit the domain of phonetic syncope by restricting the process to unstressed vowels. See 4.5.1, however, for an alternative analysis of phonetic syncope in terms of syllable timing.

#### 4.4.2 The representation of stressable and unstressable vowels

To function correctly, the rule which assigns subfeet in structures like (70) must be able to distinguish between /ə/ and the other Passamaquoddy vowels. Stowell, like Sherwood, proposes that the relevant distinction is one of length: /ə/ is short, while /i e o a/ are long. Apart from the fact that i, e, o, and a, can phonetically be either long or short (and that the shorter allophones appear to be basic), this proposal provides us with no natural way to represent inherently stressable /ə/. Certainly inherently stressable schwas are not phonetically distinct from schwas which are stressable by virtue of their positions in alternating patterns of stressability, which Stowell takes to be short.

Halle and Vergnaud choose instead to distinguish /i e o a/ and inherently stressable /ə/ from /ə/ which is not inherently stressable by means of "the diacritic mark accent," which "identifies the effective boundary of the domain; i.e., the left boundary in the case of left-headed constituents and the right boundary in the case of right-headed constituents..." (1984:[38]). Syllables with one of the vowels /i e o a/ and syllables with inherently stressable /ə/ are accented in the lexicon. (As before, certain occurrences of /i o a/ must be exempted from this provision.) Subfoot construction will respect these "previously given boundaries," by convention (p.[38]).

Halle and Vergnaud explicitly mark vowels in the lexicon as heads of subfeet, rather than making essentially diacritic-use of length distinctions. Since this approach seems preferable on methodological grounds, I will adopt it here. I return below to the question of the relative merits of accents, in the sense of Halle and Vergnaud, and of the diacritic feature [strong].

#### 4.4.3 Subfoot Formation and Foot Formation

The metrical rule which accounts for alternating stressability may now be stated as follows:

##### (71) Subfoot Formation

Construct maximally binary right-headed subfeet from left to right over the syllables in a word.

With Halle and Vergnaud, I assume that subfoot construction respects the boundaries imposed by lexical accents, so that accented syllables may only appear as heads of subfeet.

In the case of our example áka<sub>2</sub>not<sub>2</sub>máka<sub>2</sub>n, lexical accents are distributed as indicated by asterisks in (72).

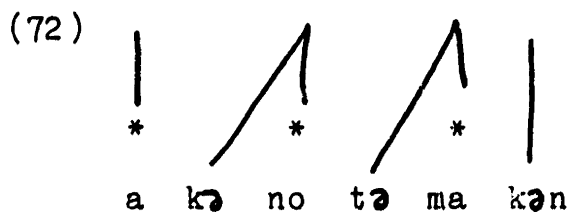

Since the accented syllable a must be the head of a subfoot, the first subfoot assigned here by (71) may not branch. The second

syllable kə is not accented, however, so it need not be the head of the second subfoot of the word, which is therefore branching. Similarly, the syllable tə is not accented, so it too is grouped with the following syllable in a subfoot. While the syllable kən is not accented, it cannot be paired with a following syllable because it is the last syllable of the word. It therefore forms a subfoot by itself, of which it is by definition the head.

Thus the procedure given in (71) will suffice to construct the subfoot structure previously assumed for the word ákanotəmakən. We have already seen that the correct relative prominence of the subfeet in (72) can be established on the basis of a right-to-left count. Let us formalize this process as a rule constructing metrical feet:

### (73) Foot Formation

Construct maximally binary left-headed feet  
from right to left over the heads of the subfeet  
in a word.

It is easy to see that this rule will group the subfeet in (72) into two binary feet, as shown in (69). Following Halle and Vergnaud, I will assume that an unbounded right-headed word tree is constructed over the heads of feet. This procedure will complete the derivation of (70). (Their framework employs grids as well as trees. I will accordingly assume that Clash Avoidance and Stress Shift are stated in grid terms, and not discuss them further in this section.)



In a word like pohtayak 'bottle (loc.),' which contains an odd number of subfeet, the first subfoot will constitute a foot of its own under (73):

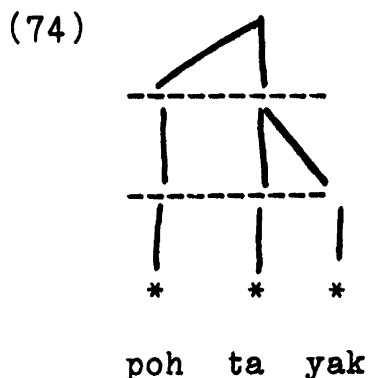

Thus we correctly continue to attribute the metrical prominence of the head of a foot to the first stressed vowel of every word, duplicating the effect of the Initial Stress Rule in the grid-based account of stress given in section 1.

#### 4.4.4 Alternating stressability

We are now in a position to see how Subfoot Formation can account for the phenomenon of alternating stressability. Consider first the word kinəw-əsə-wək (particular-AI-3-33PROX) 'they (du.) are certain ones.' The first syllable of this word is accented, as shown in (75). (In 8.1.3 I will suggest that the /ə/ of the suffix /-ək/ 33PROX is also inherently stressable, but this fact has no consequences for the present discussion, as we will see directly.)

(75) \*

ki   nə   wə   sə   wək

Subfoot Formation will set off the accented syllable ki as a subfoot by itself, then pair the other syllables of this word into right-headed subfeet as shown:



Foot Formation and the construction of a word tree convert (76) into (77), correctly designating wə as the syllable bearing primary stress and ki as the next most prominent syllable in the word.

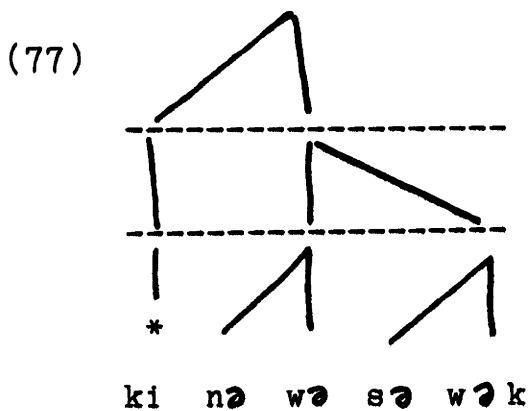



Foot Formation "sees" the schwas of the syllables wə and wək because these syllables are heads of subfeet constructed according to (71). The schwas of the syllables nə and s are "ignored" by the rule of Foot Formation because they are not heads of subfeet. Thus Subfoot Formation makes the first and third schwas in kínəwəsək unstressable while making the second and fourth schwas stressable.

The fourth /ə/ of kínəwəsək does not fall under the principle of alternating stressability as this was formulated in (18f). Because it is the last vowel in the word, it will be

stressable regardless of its even or odd position in a series of schwas, as stated in (18a). By postulating the rule of Subfoot Formation as the mechanism underlying (18f), however, we make it unnecessary to include (18a) as a separate stipulation. A word-final syllable with the vowel /ə/ will either be on the right branch of a binary subfoot, as in kínəwəsəwək above or in sítəm-ək (shore-LOC) 'shore (loc.),' or it will be left over after all of the syllables to its left have been gathered into subfeet and will therefore constitute a non-branching subfoot by itself, as in sítəm 'shore' or h-péhk-ən-əm-ən (3-completely-by.hand-TI-3IN) 'he takes it all.'

(78) a.   
 si tə mək

b.   
 si təm

c.   
 w peh kə nə mən

We see, then, that a metrical theory of the stressable/unstressable distinction allows us to account for the two generalizations (18a) and (18f) with a single statement, thus offering a potential explanation for the special treatment of /ə/ in word-final syllables. In the CV theory of stressability which

will be developed below, alternating stressability is instead brought under the same generalization as cluster effects, and (18a) requires a separate stipulation.

#### 4.4.5 Inherently stressable /ə/

The fact that inherently stressable /ə/ is excluded from patterns of alternating stressability also follows without any additional stipulation from the statement of Subfoot Formation in (71), given the device of accent marking. The initial syllables of kwácam-ək (outdoors-LOC) 'outdoors (loc.)' and ták-əm-áso (hit-TA-REFLEX-AI-(3)) 'he hits himself' are lexically accented. The treatment of these words in metrical structure assignment therefore parallels that of sítəm-ək and h-péhk-ən-ám-ən. (At the point in the derivation when metrical structure is assigned, ták-əm-áso is represented as /tək-əm-əsə-w/, from underlying /tək-əm-əsi-w/. For the change of /i/ to /ə/ before the third person suffix /-w/ and the effects of this change on stress assignment, see 4.6.) Subfoot Formation assigns metrical structure in kwácamək and tákaməsə as follows.

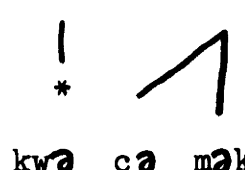
(79) a. 
  
kwə cə mək

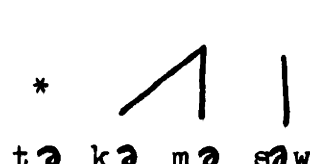
b. 
  
tə kə mə səw

Thus the first and third schwas are stressable in each form, rather than the second, as we would expect if alternating stressability held throughout the entire series of schwas in each case. (The fourth /ə/ of /təkəməsəw/ is stressable, of course, because the last syllable of this word is a subfoot by itself.)

A more complex example is furnished by the form més-ən-əm-ən-pən 'when you (sg.) got it,' which is derived by syncope from /mes-ən-əm-ən-əpən/ (get-by.hand-TI-2-PRET). The /ə/ of the second person singular suffix /-ən/ is inherently stressable. Representing this fact by means of accent marking gives us (80a) as the underlying representation of this word.<sup>10</sup> Subfoot Formation converts (80a) into (80b).

- (80) a.     \*                             \*
- me sə nə mə nə pən
- b.            |                             |
- \*                             \*
- me sə nə mə nə pən
- 

Here we see that the specification of a lexical accent interrupts the assignment of alternating stressability, which is taken up again to the right of the accented syllable. The assignment of foot structure and a word tree derives (81) from (80b), correctly designating the first and fourth syllables of mésənəmənpən as those which bear the heaviest stress.

(81)

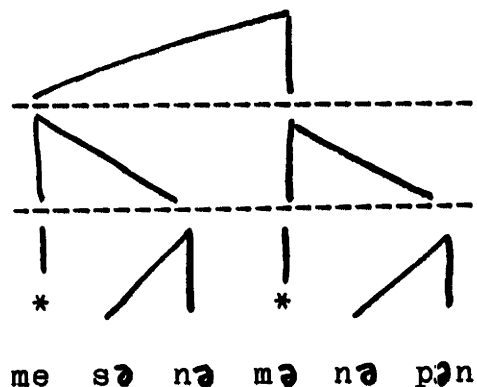

#### 4.1.6 Accent assignment rules

We see, then, that the metrical theory of stressability offers a possible explanation for the special treatment of /ə/ in word-final syllables and can easily accommodate the fact that inherently stressable /ə/ is excluded from consideration in determining alternating stressability. This approach fares no better than the diacritic theory of section 3, however, in handling the generalizations given in (18b-e). There are a variety of conditions in addition to the final-syllable condition and alternating stressability which determine when /ə/ must be treated as stressable. Not only inherently stressable /ə/ but /ə/ which is stressable by any of these conditions must be excluded from any sequence within which alternating stressability holds.

Consider, for example, the word h-pásk-ə́n-ə́m-ə́n (3-break-by.hand-TI-3IN) 'he breaks it with his hand.' We know that the /ə/ of /-ə́n-/ 'by hand' is not inherently stressable, since it is unstressable in words like h-pə́hk-ə́n-ə́m-ə́n (3-completely-by.hand-TI-3IN) 'he takes it all.' The /ə/ of /-ə́n-/ is stressable in

páskənəmən because it follows the cluster /sk/ of /pask-/ 'break,' an instance of (18b). Since we have made no provision for this generalization in our metrical theory, Subfoot Formation will proceed in hpáskənəmən just as it does in hpəkənəmən. Foot Formation and the assignment of a word tree will yield the metrical structure shown in (82), representing incorrect \*hpáskənəmən.

(82)

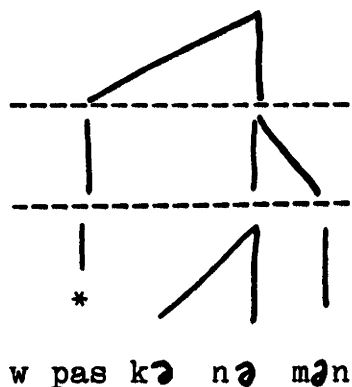

There are two ways in which we might seek to correct this defect in our metrical theory. We can postulate still another round of metrical structure assignment, one which precedes Subfoot Formation, or we can postulate rules of accent marking.

If we take the first approach, what we will need is a rule which will set up the syllable kə in hpáskənəmən as a subfoot by itself before the application of Subfoot Formation. This will give us (83a) as the input to Subfoot Formation and (83b) as its output, since this rule respects "previously given boundaries." The metrical structure (83c) which will then result is appropriate to the stress pattern of hpáskənəmən.

(83) a.

\* |

w pas kə nə mən

b.

! | / |

\* | |

w pas kə nə mən

c.

/ |

---

| | / |

---

! | |

\* | |

w pas kə nə mən

The alternative is to postulate a rule which supplies an accent for the syllable kə but does not actually build metrical structure. It is easy to show that this move will have the same effect as the procedure outlined in (83). The accent of our accent assignment rule will be (84a). Since accents define right boundaries of subfeet, the output of the application of Subfoot Formation to (84a) is (84b), equivalent to (83b).

(84) a.

\*   \*  
w pas kə nə mən

b.

!   !   / |

\*   \*   | |

w pas kə nə mən



Since there are more possible ways to build metrical structure than there are to assign accents, the first of these approaches involves considerably more arbitrariness than the second. We might ask, for instance, why we should build a non-branching subfoot over the syllable which contains a /ə/ following a cluster. Why not, say, a left-headed binary subfoot, a branching structure with this syllable as its head? (Such an alternative would, among other things, make the final syllable unstressable in məsk-əm-ən ((3)-find-TI-3IN) 'he finds it,' thereby incorrectly throwing primary stress back to the antepenult in this form.) By restricting ourselves to modifying accent marking, we limit the possible types of subfeet to those which can be constructed by Subfoot Formation. Accent marking therefore seems like the better choice for a mechanism to use in extending the metrical theory of stressability to accommodate (18b-e).

A possible formulation of the accent assignment rule needed to express the effect of (18b) is given in (85). (Here I assume that assigning accent to a vowel is equivalent to assigning accent to the syllable which contains that vowel. We will not need such a convention if we choose to construct metrical structure over vowel projections.)

\*

$$(85) V \dashrightarrow V / \quad C \quad C \quad \underline{\quad}$$

[-laryngeal]

We will have occasion below to consider whether this rule might better be formulated in terms of syllable structure.

We will also need accent assignment rules corresponding to (18c-e). Schwa must be accented after /hl/, or we will derive \*ac-ehl-əso (or perhaps \*ac-el-so) in place of ac-ehl-əso (change-TA-REFLEX-(3)) 'he changes himself.' Schwa must be accented between /s/ and /hs/, or we will derive \*skənís-əss-is (or \*skənís-s-is) rather than skənís-əss-is (bone-DIM-DIM) 'bone (dim.)'. Finally, the first /ə/ in word-initial / (C)ə [+sonorant]ə / must be accented, or we will derive \*pəm-əka instead of pəm-əka (along-dance-(3)) 'he dances.' The required accent rules are given in (86).

- \*
- (86) a. V --> V / h l \_\_\_\_
- \*
- b. V --> V / s \_\_\_\_ h s
- \*
- c. V --> V / # (C) \_\_\_\_ [+sonorant]  $\check{V}$

In (86c), I use the notation " $\check{V}$ " to indicate an unaccented vowel.

The last of these rules is particularly interesting from the point of view of a metrical framework. Since two unaccented vowels are involved here, it might seem appropriate to build a left-headed binary subfoot over the syllables involved rather than simply to accent the first. Alternatively, we might say that what is really going on in these cases is that the first right-headed subfoot constructed in the words which fall under (18e) is subject to a reversal in parity, becoming a left-headed subfoot through a sort of segmentally conditioned stress shift rule:

(87)

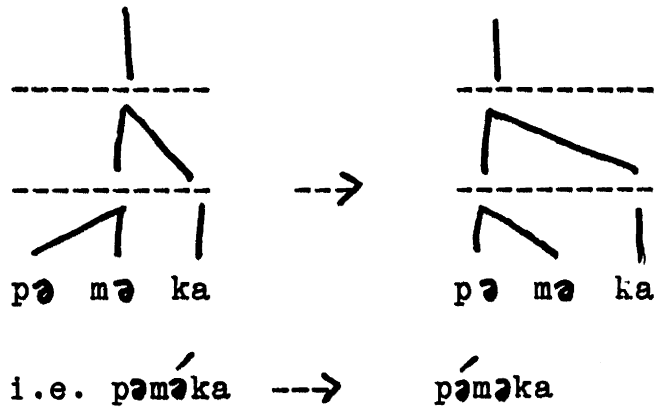

Both of these proposals make incorrect predictions, however, in cases where a longer series of schwas is involved. For example, if the first two syllables of the word əl-ən-əm-əw-a-t (thus-by.hand-TI-TA-DIR-3AN) 'he hands it to the other' are grouped into a left-headed subfoot, we will build the following tree. The stress pattern of the word is then incorrectly derived as \*ələnəmówat (with ə for /ə/ in stressable position before /w/).

(88)

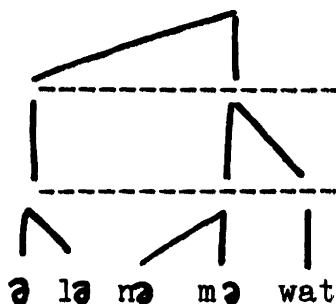

What we want instead is the tree shown in (89). This is the result we obtain by accenting the first /ə/ in this word, thus obliging Subfoot Formation to build a non-branching subfoot in this location.

(89)

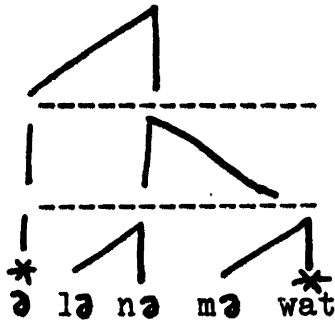

By restricting ourselves to using accent marking to handle the generalization given in (18e), we again correctly limit the class of metrical structures that can be constructed.

#### 4.4.7 Strengths and weaknesses of the metrical analysis

The rules which have been proposed in this section to model the stressable/unstressable distinction in metrical terms are summarized in (90), following the format of the descriptive statement (18).

(90) a. /ə/ in final syllables: falls under (f)

\*

b. V → V / C C \_\_\_\_  
[-laryngeal]

\*

c. V → V / h l \_\_\_\_

\*

d. V → V / s \_\_\_\_ h s

\*

e. V → V / # (C) \_\_\_\_ [+sonorant]  $\check{V}$

f. Subfoot Formation (71)

This system of rules has two principal advantages over the corresponding set of rules ((67) above) required in the diacritic theory of section 3. First, it permits us to eliminate one rule, since the special treatment of /ə/ in final syllables, generalization (18a), is now simply a case of the rule which is motivated by (18f), alternating stressability. Second, it permits us to rationalize the iterative character of the rule for alternating stressability, and the apparent syllable-counting which this rule involves, by referring these properties to general principles of the metrical framework. This framework also permits us to avoid explicit reference to diacritic properties of the representations which are inputs to the assignment of alternating stressability, since the role of accents in regulating the application of Subfoot Formation follows from general conventions and need not be stated in the rule itself.

The accent is, moreover, arguably superior to the feature [strong] as a diacritic device. There is no reason, in principle, why [strong] could not be a feature of consonants as well as of vowels, permitting an even greater variety of rules determining the distribution of stressable vowels. For example, we might imagine a rule of "assimilation" which would make a "weak" vowel "strong" just in case it precedes a "strong" consonant. Since an accent is not a diacritic feature, but rather a device specific to metrical theory, it can in principle be assigned only to syllables (or to vowels, the "heads" of syllables).

Our metrical theory nonetheless continues to make extensive use of a diacritic device, at least if accents are regarded as a way of encoding directions for the later assignment of metrical structure. Note, however, that we might instead take accents to be boundaries of metrical constituents, provided that we are willing to accept the idea that such constituents can have, say, a right boundary but no left boundary (for part of a derivation). On this view, accents might be regarded as structural features of phonological representations, on a par with segments or syllables, and not as diacritics at all.

Yet this proposal would commit us to manipulating constituent boundaries in novel ways which essentially recapitulate the complex adjustments in the values of the feature [strong] for which we criticized the diacritic theory above. Under such an interpretation, the four accent assignment rules given in (90) would represent processes which assign right boundaries of subfeet without actually constructing the subfeet

themselves. Moreover, (90e), the rule for initial /((C)ə [+sonorant]ə /, must still assign an accent in the environment of an unaccented vowel. This rule must therefore explicitly refer to the absence of a constituent boundary.

Nor does the metrical theory offer any greater insight than the diacritic approach into the nature of the environments which trigger accent assignment. Why should /ə/ be accented after clusters other than /hC/? Why after /hl/ if not after other /hC/ clusters? Why is /ə/ accented by (90e) in the environment of an unaccented /ə/ which is then incorporated into a different metrical constituent?

Since (90b) has the effect of accenting the vowel of a syllable which follows a closed syllable, we might hope to gain some insight into this process by formulating the rule in these terms (although it would seem more natural for a metrical system to result in stress on a closed syllable rather than stress on one which follows). But (90b) must in any case be applicable where / / follows a word-initial cluster, where a restatement of this type would not be possible. This is true for all speakers in words like (w)-m<sup>́</sup>s-ən-əm-ən (3-get-by.hand-TI-3IN) 'he gets it,' where the use of a personal prefix produces an initial cluster. Many speakers also have word-initial clusters as a result of reanalysis of initials which formerly began with a syllable containing a syncope vowel. (An example is /sp-/ 'above,' earlier /asp-/ with syncope /a/. Speakers who have maintained the older underlying form have nt-ásp-ə̀p (1-above-sit) 'I sit up high,' while speakers who also or instead use the reanalyzed initial allow n-sp-ə̀p in the same meaning. But

speakers of both groups have sp-ápo (above-sit-(3)) 'he sits up high,' with a stressable surface vowel for the underlyingly unstressable /ə/ of /əpi-/ 'sit.')

A more general criticism can also be lodged against the metrical theory of stressability: this analysis essentially requires us to stipulate the outcome of subfoot formation in the unmarked cases, while treating the marked cases as the norm.

It is clearly the unmarked case for a Passamaquoddy vowel simply to be stressable: most occurrences of /i/, /a/, and /o/ are inherently stressable, as are some occurrences of /ə/. Paradigm leveling and other types of reanalysis frequently involve the establishment of new occurrences of inherently stressable vowels. But our rule which establishes subfeet mentions no specific vowels; and indeed it must not, since this rule must be able to treat underlyingly unstressable /i/, /a/, and /o/ like underlyingly unstressable /ə/ if we are to account for the cases of syncope of i, a, and o which will be discussed in Chapter 6.

Our formal statement of subfoot formation thus makes an implicit claim that alternating stressability is the normal situation for Passamaquoddy vowels: without some additional provision, we would incorrectly produce alternating patterns of stressability throughout all Passamaquoddy words. We avoid this consequence by introducing lexical accents (and accent assignment rules). But it is precisely the role of lexical accents to stipulate the boundaries of metrical constituents. Thus to insure the proper assignment of metrical structure by Subfoot Formation we must stipulate for the majority of vowels in



underlying representations in Passamaquoddy that this rule does not apply to them in the expected way. The marked cases -- underlyingly unstressable vowels -- are handled without any special stipulations.

This is clearly an undesirable result. The device of accent marking makes it possible to handle cases of marked or exceptional structure assignment within otherwise general systems of metrical rules. To use accent marking to handle unmarked cases of structure assignment is thus to fail to recognize their unmarked status. Presumably, in fact, the evaluation metric should attach a high cost to the use of accents, just as it will to the use of diacritic features. In any case, a theory in which unstressable vowels have a marked status should certainly be preferred over one in which we must stipulate for every inherently stressable vowel that it does not receive the treatment of an unstressable vowel. The CV theory of stressability which is developed in the following section treats underlyingly unstressable vowels as marked.

#### **4.5 A CV theory of stressability**

Michelson (1986) has shown that the stress rule of Mohawk skips over certain vowels because they are not associated with slots on the CV or timing tier at the point in derivations when stress is assigned. In this section I will develop a theory of the stressable/unstressable distinction in Passamaquoddy which is based on a similar proposal: stressable vowels are segments which are linked to V-slots in the structures to which the stress rules are applicable, while unstressable vowels are floating

[-consonantal] segments at this point in derivations. Because stressable and unstressable vowels are structurally distinct in this analysis, no diacritic device is needed to distinguish them. Since the stress rules assign prominence to syllables (or to vowels, if we formulate them in terms of vowel projections), the invisibility of unstressable vowels follows from the nature of the representations that we have given them: segments which are not associated with timing slots have no representation on the CV tier and are therefore not accessible to rules of syllabification or stress assignment, since these rules are defined, directly or indirectly, over elements of the timing tier.

V-slots are introduced for certain underlying floating segments, making them stressable, under conditions which are partially determined by syllabification: the inserted V-slots typically make it possible to syllabify underlying C positions which could not otherwise be incorporated into a syllable. Thus the formal distinction between floating segments and segments which are linked to V-slots gives us a way to relate the conditions which determine stressability in Passamaquoddy to the principles which define the class of well-formed syllables of the language and does not merely constitute a diacritic use of phonological structure.

I will assume that all segments in the underlying representations of Passamaquoddy words except underlyingly unstressable vowels are linked to timing slots. It is certainly the unmarked case in languages in general for all of the segments in a word to be associated with slots on the timing tier. Let us therefore suppose that the slots associated with underlyingly

stressable vowels come "for free," while the evaluation metric will always assign an extra "cost" for each floating vowel in an underlying representation.<sup>11</sup>

For the most part, an underlying distinction between segments which may be marginal elements in syllables and segments which function as syllabic nuclei is sufficient to assure that the rules which I will propose will apply correctly. The CV phonology of Clements and Keyser (1983) accordingly provides a convenient framework for our analysis, since their theory of the timing tier postulates elements of just these two types (represented as C's and V's respectively). Although there are a few exceptional cases in which it is necessary to stipulate the syllabification of certain C-slots in underlying forms, I know of no rule in the phonology of Passamaquoddy which must be stated in terms of the constituent structure of syllables. For this reason, I will also follow Clements and Keyser in postulating a "flat" or non-hierarchical structure for the syllable in Passamaquoddy, although nothing in the proposed analysis depends upon this assumption.

The status of most underlying segments as C's or V's is predictable from their feature composition, but the distribution of high vowels and glides is not predictable in underlying forms. Obstruents and sonorant consonants are always linked to C-slots in underlying forms, although syllabic l, m, and n occur in phonetic representations. There are no /e/, /a/, or /ə/ glides at any level of representation, so all such segments (except for unstressable /a/ and /ə/) are linked to V-slots. I assume that regularities of this kind, like the fact that all segments have

slots in the unmarked case, can be stated by means of redundancy rules over underlying representations which are fully specified in the relevant respects. Segments with the features of /i/ and /u/ may be associated with either C's or V's in underlying forms. In particular, underlying /w/ may function as an unsyllabified C-slot in triggering rules of V-slot epenthesis.

Five rules which insert V-slots on the timing tier will be proposed in this chapter. All are "phoneme driven" in the sense that they insert slots only in positions where there are floating segments. Four are ordered before the stress rules and therefore serve to derive stressable vowels from underlyingly unstressable vowels.<sup>12</sup> It is these rules which account for the generalizations of (18) in the CV theory of stressability. One is ordered after stress assignment and serves to provide slots for those underlying floating vowels which are not subject to syncope and therefore appear as unstressable vowels in surface forms.

I will argue below that this CV theory provides a more explanatory account of the distribution of stressable and unstressable vowels than either of the alternative accounts of the last two sections. Nevertheless, the proposed reanalysis requires us to abandon two attractive features of the metrical theory. The rule of V-Epenthesis, which accounts for alternating stressability in the CV theory, must apply iteratively. If this is the right way to represent the left-to-right dependencies which the data clearly reflect, then iterative application cannot be restricted to metrical rules. The special treatment of /ə/ in word-final syllables, which can be neatly derived from

alternating stressability under the assumptions of the metrical framework, requires a separate rule of epenthesis in the CV theory.

On the other hand, the effect of counting off schwas by pairs can be derived, in the CV analysis, from the interaction of epenthesis and syllabification. Thus the CV theory of stressability does not require us to attribute the power of syllable counting to non-metrical rules. Moreover, if the CV theory is accepted, then there is no need to postulate three-tiered metrical structures in order to account for the facts of stress assignment in Passamaquoddy. Eliminating such three-tiered systems in general would permit an important reduction in the expressive power of metrical theory.

#### 4.5.1 Unstressable /ə/

In the grid based stress theory developed in section 1, the stress pattern of a word like póhtáya-k 'bottle (loc.)' is derived as shown in (90). First we align each syllable of the word with a demibeat, or grid position on the lowest metrical level. Then the first demibeat in the word is aligned with a beat on the second metrical level by the Initial Stress Rule and the penultimate demibeat in the word is aligned with a beat by the Alternating Stress Rule. Finally the right-hand beat is aligned with a third-level grid position by the Main Stress Rule.

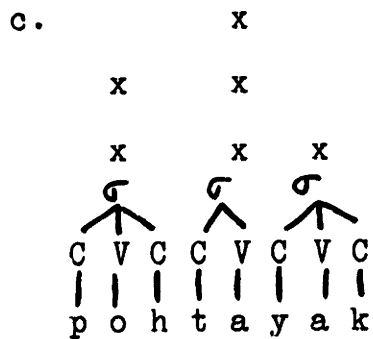
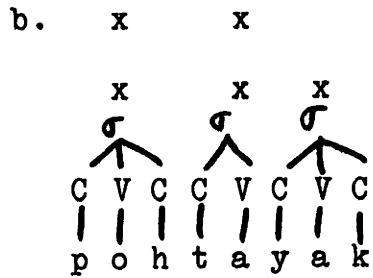
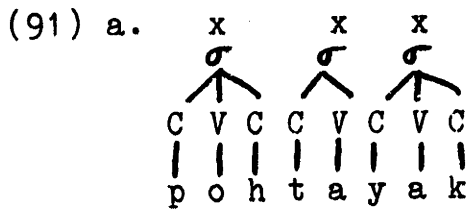

If we apply the same procedure to the word sók-əlán (pour-rain-(3)) 'it pours (rain)' in terms of its surface syllabification, we will incorrectly derive \*sók-əlán, since there is nothing to distinguish this word from póhtáyak:

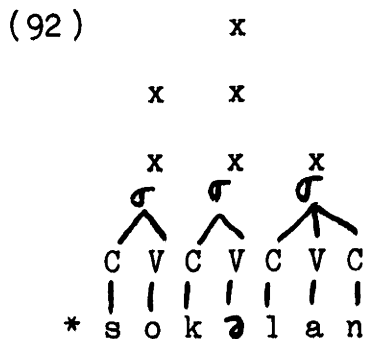

Suppose, however, that there is no V-slot associated with the /ə/ of sók-əlán at the point in the derivation of this word when the

stress rules apply. Since rules of syllabification organize a word in terms of its CV structure, sók-əlan will be a bisyllabic word at this point:

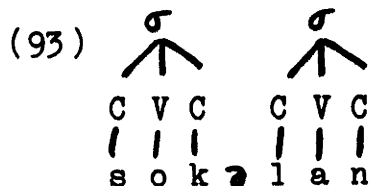

Our procedure for constructing a metrical grid looks only at a sequence of syllables, not at the segmental structure of a word. We will accordingly treat sókəlan like any other bisyllabic word in assigning stress. Stress and ultimately main stress will be assigned to the first syllable of the word: its /ə/ is invisible to stress assignment.

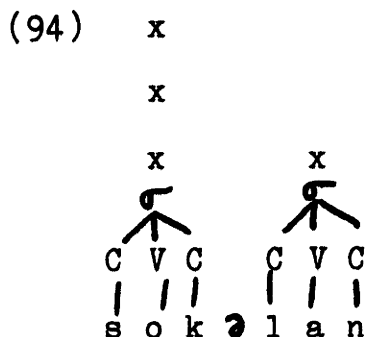

At least in deliberate speech, the k of sókəlan forms the onset of a syllable of which the following ə is the nucleus. To derive this result, we need a rule which is ordered after stress assignment and which provides a V-slot for the floating /ə/ in (94). If we circle an element to indicate that it is not associated with any unit of the CV tier, we can write this rule as follows:

(95) Schwa Support

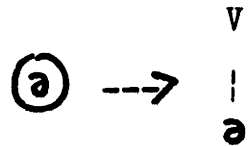

If /k/ is subject to resyllabification after the application of Schwa Support, then (95) will convert (94) to (96).<sup>13</sup>

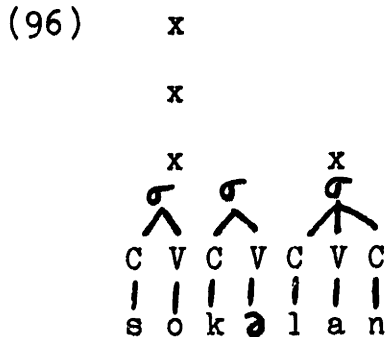

This is the right result: we now have stress on the first syllable of a trisyllabic word with no stress on the second syllable.

One problem remains, however. The syllable kə of (96) is not aligned with a grid position. In Selkirk's framework, the metrical grid is the mechanism which accounts for syllable timing. But we do not want to say that no time is allotted for the pronunciation of the second syllable of sókəlan: it has not been deleted. A similar problem arises with the initial syllable in a word like pəmi-ph-â (along-carry-3PASS) 'he is carried along.' Since this syllable contains an unstressable vowel, it too will remain without a grid position if unstressable vowels are floating segments at the point in derivations when syllables are aligned with demibeats.



Now of course we could simply adopt a convention which would supply additional grid positions for syllables which arise late in derivations. A more interesting solution is possible, however, one which invokes the status of unstressable vowels in metrical grids to account for their special phonetic properties.

Let us suppose that a syllable which is not itself aligned with a demibeat is allotted part of the timing interval assigned to an adjacent syllable, according to the following principle:

(97) Shared Timing Principle

A syllable which is not aligned with a demibeat is assigned a share of the time allotment of the preceding syllable, if there is one, otherwise of the following syllable.

If we follow this procedure, the syllable kə of sókəlan will share a timing interval with the syllable so, which precedes it. Since no syllable precedes pə in pəmíphâ, this syllable will share a timing interval with the syllable mip, which follows it.

Given this principle, and reasonable assumptions about what it might mean to share a timing interval, we can make certain predictions about the phonetic realization of unstressable ə. In particular, it seems natural to suppose that the actual phonetic length of an unstressable ə will vary with the phonetic length of the syllable whose timing interval it must share. After a phonetically long syllable, an unstressable ə should be relatively short; but a phonetically short syllable should be followed by a relatively fully pronounced ə. This prediction

appears to be borne out by the facts, at least in its broad outlines. In a word like psehpan-ək 'onions,' for example, in which e is phonetically a long vowel [æ̃] because of the following hC, the ə of the next syllable is generally quite short and frequently omitted altogether. After the relatively short a of ákam-ək 'snowshoes,' however, unstressable ə is comparatively long and would not ordinarily be deleted except at a high rate of speech. Thus the Shared Timing Principle provides a plausible basis for an explanatory account of the phonetic properties of unstressable surface ə. Note, too, that this account in no way depends on an assumption that stressable schwas are distinguished from unstressable schwas in phonetic representations by bearing minimal stress.

#### 4.5.2 V-Epenthesis

Consider next the word písk-əlán (dark-rain-(3)) 'it rains so hard that it is dark or hard to see.' Since this final contains the same final /-əlán-/ 'rain' as sók-əlán, we may assume that its underlying form is (98). (I will ignore the third person suffix here and below where its presence has no effect on stress placement.)

(98) C V C C    C V C  
       | | | |    | | |  
       p i s k ə l a n

Suppose, now, that písk-lan is initially syllabified as shown in (99), as a bisyllabic word in which one C remains unsyllabified.

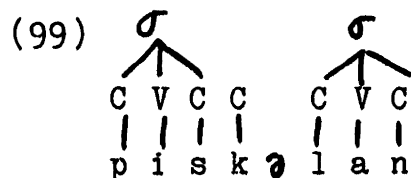

If everything now precedes as in the derivation of sok-əlan, we will again end up with stress only on the initial syllable of the word, an incorrect result in this case.

Suppose, however, that (99) is subject to rule (100), which associates an epenthetic V-slot with a floating vowel which follows an unsyllabified C-slot (noted C').

(100) V-Epenthesis

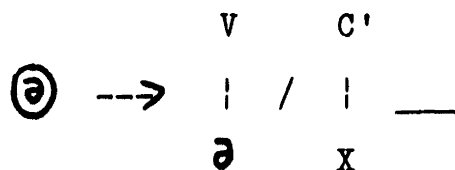

Here X is a variable over arbitrary feature matrices. This variable is required in order to state the relative positions of the C' and the floating /ə/ which trigger the rule, since the elements of one tier are not ordered with respect to those of another except in terms of relationships established by association lines. I have formulated V-Epenthesis so that it will insert a V-slot only where there is a floating /ə/, because there are a variety of reasons (as we will see below) to postulate extrasyllabic consonants which are not followed by floating vowels and which do not trigger the rule.

V-Epenthesis will add a V-slot where an extrasyllabic C is followed by a floating vowel, making it possible to associate



### 4.5.3 Syllabification

Clusters of two non-syllabics are fairly free in Passamaquoddy, even initially and finally in a word: ptahma 'he hooks a fish,' tpéltam 'he owns,' nítkw 'my eyebrow,' nékw 'one.' Clusters of three non-syllabics, on the other hand, are virtually always of the form CsC, although these too may occur initially, medially, or finally: pskwácis 'war club,' kspíson 'belt,' nékwskikwéssoss 'woodcock,' mácmiskíhkwál 'poison ivy (pl.),' ksiúwsk 'hemlock,' panápskw 'stone.' Clusters of more than three non-syllabics are generally excluded. (See 3.4 for further examples, some additional restrictions, and a handful of sporadic exceptions to these generalizations. One regular class of exceptions is discussed below.)

Now if sequences like tkw or wsk can end a syllable and sequences like pt or pskw can begin one, then we might expect to find medial clusters like tkwpt or wskpt or even wskpskw: these would simply consist of a possible syllable-final sequence followed by a possible onset. But of course no such clusters are possible. Clearly, then, some provision is required which permits more non-syllabic segments to begin a word than can ordinarily begin a syllable and permits more non-syllabic segments to end a more than can ordinarily end a syllable.

We can achieve the required effect as follows. Suppose first of all that a single unsyllabified C is permitted at either margin a a word, but not medially. This restriction can be expressed as the filter (103). (At this point we are concerned

only with distributional facts. A static template, rather than a filter, might seem appropriate for these cases. I will suggest in 4.6, however, that a constraint like (103) may also be function to rule out certain derivations.)

(103) Unsyllabified Consonant Filter (UCF)

$$* \left[ \begin{array}{ccc} X & C' & Y \\ \text{Word} & & \end{array} \right], \text{ unless X or Y is null.}$$

The UCF will mark as deviant any word in which a C position remains unsyllabified, unless it is marginal in the word. (I will assume that this filter applies only late in derivations: we will see below that it is useful to postulate underlying and intermediate phonological representations for many words which contain unsyllabified C-slots.)

C positions are permitted where they can be syllabified by one of the following rules:

(104) a.

$$\begin{array}{ccc} \sigma & & \sigma \\ | & \dashrightarrow & / \backslash \\ C & V & C & V \end{array}$$

b.

$$\begin{array}{ccc} \sigma & & \sigma \\ | & \dashrightarrow & / \backslash \\ V & C & V & C \end{array}$$

(105) a.

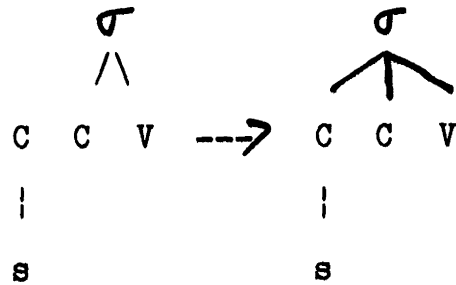

b.

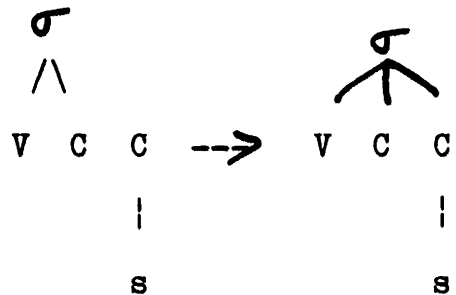

The first two rules will incorporate any non-syllabic segment into a syllable if it immediately precedes or immediately follows a vowel. The second two rules will incorporate an additional /s/ at the beginning or end of any syllable which can be formed by applying one or both of the first two.

I will assume that (a) takes precedence over (b) in the rules of either set: to this extent, onsets are maximized. Thus VCV will be syllabified V.CV and VCsCV as VC.sCV. I will further assume, however, that VsCV is syllabified as Vs.CV, that is that (104b) takes precedence over (105a). The syllable boundaries that we will set up in this way are consistent with the fact that s is phonetically long in a word like épeskóme 'he plays ball,' but not, for example, in pápskótek 'stove (loc.).' (Here the second p is long instead.) It appears that the rule which determines phonetic length of the consonants in these cases lengthens a syllable-final non-syllabic segment before another non-syllabic.

Initially in a word, the constraints imposed by the syllabification rules (104)-(105) and the UCF will permit a single extrasyllabic segment followed by a syllable-initial cluster sC. Thus the longest initial clusters are of the form CsC. Medially, we could in principle have Cs followed by sC, for a maximum of CssC. But single consonants and geminates are not distinct in clusters, so this case, too, reduces to CsC. (In practice, then, (105b) is applicable only in the last syllable of a word, since s in medial CsC will always be syllabified by (105a).) Word-finally we can have syllable-final Cs plus an additional extrasyllabic C: again CsC. Thus (103)-(105) correctly constrain the class of possible clusters of non-syllabics in Passamaquoddy.

A process of reduction which affects certain initial clusters provides additional evidence that some words begin with an extrasyllabic segment. Word-initial k is frequently omitted before another consonant, especially by younger speakers: kpáhmon ~ páhmon 'shut (sg.) it!'; ktáhkəmikw ~ táhkəmikw 'land'; kskəcəkəkən ~ skəcəkəkən 'it is wide.' Other consonants are also sometimes omitted under comparable circumstances, although perhaps not as often: ptéwələn ~ téwələn 'person with supernatural powers.' The frequent omission of the personal prefixes n- and k- before a consonant might plausibly be attributed to the same cause. Initial s is not subject to this type of deletion, however. We do not, for example, hear \*kənis for skənis 'bone.' If we formulate the rule in question so that it deletes initial 'C', this distinction will follow automatically: k, p, n, etc. will be candidates for deletion



because they remain unsyllabified word-initially before another non-syllabic, but s will not, since s can be syllabified before a C at the beginning of a word by (105a).

#### 4.5.4 V-Epenthesis and syllabification

Let us return to our example pisk-əlan 'it rains so hard etc.' If we again ignore the third person suffix, the underlying form of this word is as shown in (106): all of the segments except the underlyingly unstressable /ə/ of /-əl-an-/ are associated with slots on the CV tier.

(106) C V C C C V C  
 | | | | | | |  
 p i s k ə l a n

The application of (104a) converts (106) to (107a), and (104b) gives (107b). The rules of (105) are not applicable.

(107) a.  $\sigma$   $\sigma$   
 / \ / \  
 C V C C C V C  
 | | | | | | |  
 p i s k ə l a n

b.  $\sigma$   $\sigma$   
 / \ / \  
 C V C C C V C  
 | | | | | | |  
 p i s k ə l a n

The resulting structure is the same as the one that we posited in 4.5.2 as the input to V-Epenthesis. Applying this rule, we derive (108). (With Clements and Keyser, I assume that the

introduction of a V position introduces a syllable node, by convention.)

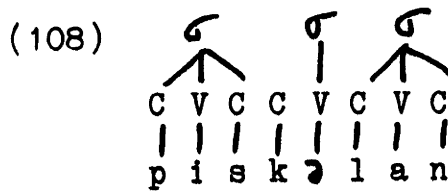

As we noted before, we must now assume that syllabification can take place after the application of V-Epenthesis. In particular, (104a) applies to (108) to give (109).

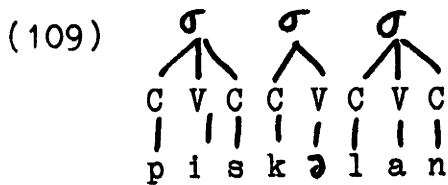

The resulting trisyllabic word is now submitted to the stress rules, giving piskalan. We see, then, that the syllabification rules of (104), which were motivated solely on distributional grounds, provide a principled basis for postulating V-Epenthesis as a way of stating the fact that underlyingly unstressable /ə/ becomes stressable after /sk/.

We can handle the effects of a variety of other types of clusters in the same way. For example, in tekk-əpi-t (as.far-sit-3AN) 'as far away as he sits,' the underlyingly unstressable /ə/ of /əpi-/ 'sit' will become stressable through the application of V-Epenthesis. The underlying form of this word is given in (110a). Syllabification rules (104a) and (104b) will turn this structure into (110b): the second C-slot associated with the geminate /k/ of /tekk-/ cannot be syllabified.

(110) a. C V C C C V C  
 | | | | | | |  
 t e k ə p i t

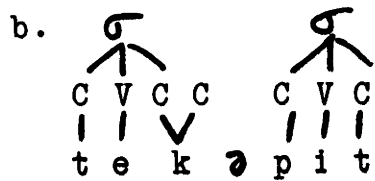
b. 

Here again V-Epenthesis is applicable and turns tékkəpit into a trisyllabic word in the input to stress assignment, thus accounting for its stress pattern:

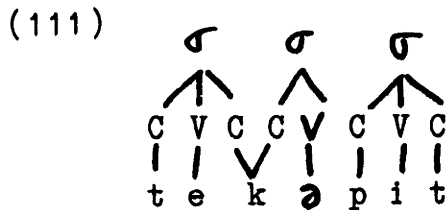
(111) 

Clusters of the form /hC/, however, do not have the effect on stressability that we would expect on this account in those cases in which C is an obstruent. Consider, for example, the word hpehk-ən-a-l 'he takes all of it (an.)', from /w-pehk-ən-a-l/ (3-completely-by.hand-DIR-3.OBV). Given the representation in (112a), the rules of syllabification that we have postulated up to this point will yield (112b).

(112) a. C C V C C C V C  
 | | | | | | |  
 w p e h k ə n a l

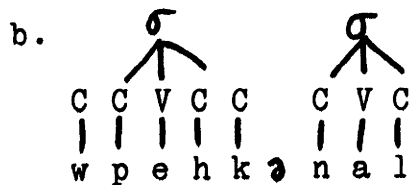
b. 

But if (112b) is the input to V-Epenthesis, then the stress rules will see apply to this word in the form shown in (113).

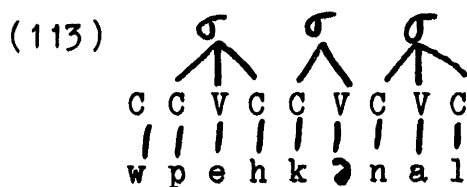

The result, after Initial Devoicing, will be the incorrectly stressed form \*hpehkənal.

This derivation goes astray because the /k/ of /pehk-/ is left unsyllabified in (112b). If this consonant were syllabified as shown in (114), V-Epenthesis would not be applicable.

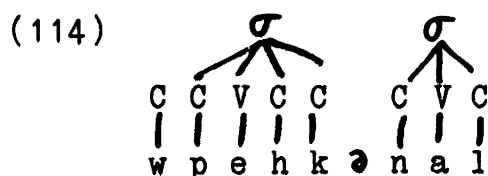

The result of applying the ISR and the ASR to (114) is (115a). If this structure then undergoes Schwa Support and (104a) is allowed to reapply, the result will be (115b). This is an appropriate representation for hpehkənal in the input to Initial Devoicing.

(115) a.

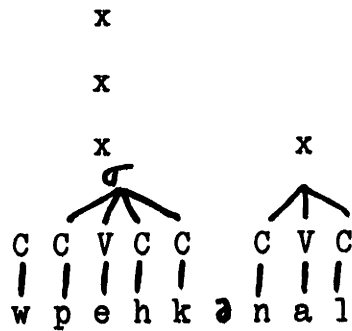

b.

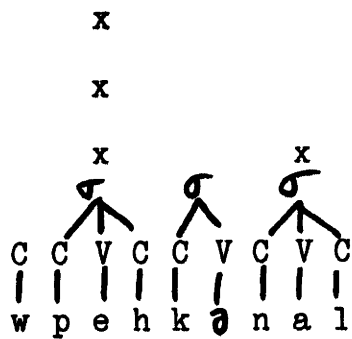

It is clear, then, that the fact that /ə/ remains unstressable after clusters of /h/ and an obstruent can be accounted for by postulating a rule which will permit syllable-final /hC/ clusters:

(116)

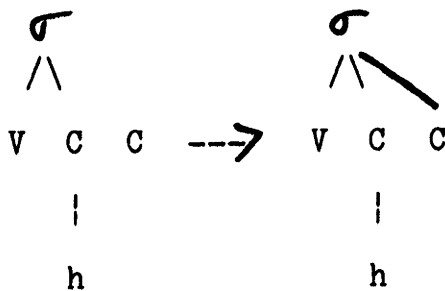

Is there any independent evidence for such a rule?

The first point to note is that word-final clusters of h and an obstruent are quite common: tələhp 'playing card,' kísi təkəmiht 'he whom the other hit,' pskəhc 'have the other find him,' ətóhk 'deer,' skà étələlohkəwəkw 'we (du. inc.) who are not working,' kísohs 'sun, moon, month.' We see, then, that

there is a large class of forms which can plausibly be interpreted as exemplifying just the kind of syllable-final clusters that (116) would admit into the Passamaquoddy canon.

Of course, adopting (116) would also open up the possibility of various medial clusters of the form hCC or even hCsC: these would be made up of syllable-final hC followed by syllable-initial C or sC. There are two points to consider here. First, such clusters are for the most part excluded on independent grounds. Second, one class of clusters of this type is regularly permitted by some speakers.

For all speakers, /h/ is deleted before clusters by a rule which I call H-Deletion III, which will be discussed in detail in 5.8.1. For example, underlying /pehsəwəhsəwəhsək-il/ (flower-33IN) becomes /pehsəwəhsə<sup>w</sup>əshsk-il/ by syncope, but surfaces as péhsəwəhsəwésk-il 'flowers' as the result of the application of H-Deletion III.

For many speakers, H-Deletion III eliminates all potential sequences of the form hCC. Some speakers, however, apparently have an optional rule which reduces certain occurrences of VhV to (hV) and is ordered after H-Deletion III. (This rule too will be considered in more detail in 5.8.1.) Clusters of the form hCh which result from this reduction are retained on the surface: speakers in this group have tóhpihil ~ tóhphil 'alders,' sáhtihil ~ sáhthil 'blueberries.'

Now the second h in clusters of this type is phonetically [h]. These regularly derived hCh clusters contrast in this respect with the CCh clusters that we find in a handful of exceptional items like sonkháhso 'he (a dog) rolls around in the

dirt,' where the non-canonical cluster nkh is phonetically [nk<sup>h</sup>]. We can account for the differing phonetics of post-consonantal h in these two classes of cases -- and at the same time explain how items of both types escape the Unsyllabified Consonant Filter -- if we suppose that hCh in the output of the reduction of VhV is syllabified hC.h, while CCh in exceptional forms like sónkháhsó is syllabified C.Ch. In the first case, we will have syllable initial h, which is ordinarily realized as phonetic [h]. In the second case, we will have syllable-initial Ch, a plausible source for an aspirated consonant. We may assume that a form like sónkháhsó is listed in the lexicon with idiosyncratic syllabification: it is precisely the fact that there is no general rule which will permit full syllabification of medial /nkh/ which is responsible for the exceptional character of this form. The syllabification of words like tónphil and sáthil which, in this way, will allow us to accommodate the phonetics of h in these cases, is that provided by the proposed syllabification rule (116). Thus the phonetics of these forms thus provides additional evidence for a rule with the effect of (116).

As we seen, the introduction of (116) will allow us to derive the stress patterns of words like hpehk nal without complicating the statement of V-Epenthesis. Forms in which underlyingly unstressable /ə/ follows /hl/ now become a problem, however. Given (116) as stated, the word ác-ehl-əso (change-TA-REFLEX-(3)) 'he changes himself' will be syllabified as follows in the input to stress assignment:

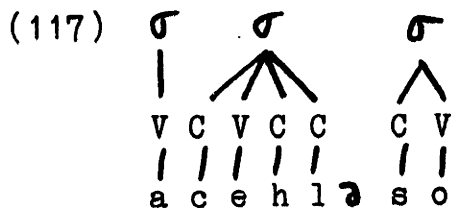

The result will be \*ácehləso or ácelso, depending upon whether or not syncope takes place. Neither form is acceptable.

To derive the right stress pattern for ácehləso, what we need instead is the syllabification shown in (118).

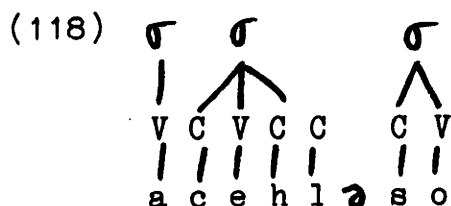

If /l/ remains unsyllabified here, it will trigger V-Epenthesis, giving (119a). The stress rules will then yield (119b), ácehləso as required.

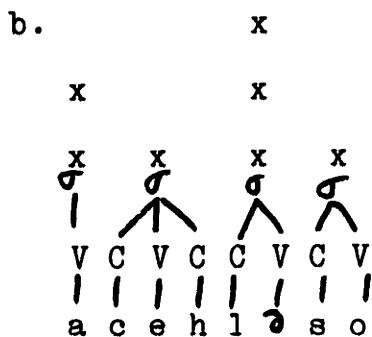
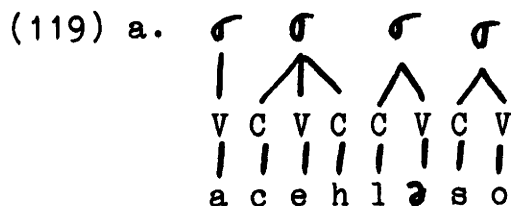



The syllabification shown in (118) will result if we modify rule (116) so that it will only incorporate an obstruent into a syllable which ends in /h/:

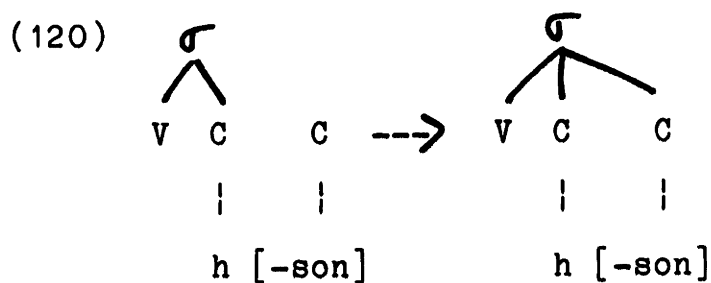

Of course, if we make this change we will not only exclude /hl/ from syllable-final position, but bar other clusters of /h/ and a sonorant from this position. We might therefore expect to find cases in which underlyingly unstressable / $\emptyset$ / becomes stressable after /hm/, /hn/, or /hy/, since the second member of any of these clusters should trigger V-Epenthesis. As it happens, however, no relevant cases arise, since these clusters are all very rare in underlying forms. (Although hm is common in surface forms, almost all occurrences of this cluster are derived by syncope from underlying /h $\emptyset$ m/, as we will see in 5.6.1.)

The evidence of surface segmental distributions is also consistent with the proposed revision of (116). I have encountered no cases of hCh in which C is a sonorant. The word that I know of which ends in an h-sonorant cluster is n $\emptyset$ hm, a by-form of n $\emptyset$ m 'turkey.' (Underlying /h/ is regularly deleted when it comes to stand before word-final /m/ in the course of a derivation. See 5.6.2 for discussion.) Restricting (116) to obstruents thus insures that the rule will only construct syllables of types which are regularly found in surface forms.

Given the syllabification rules (104) and (120), we can explain why clusters of /h/ and an obstruent pattern like single segments with respect to the conditions which determine stressability, and why /hl/ is singled out for special treatment. When /C/ in /hC/ is an obstruent, both segments can be syllabified with a preceding vowel. Thus neither C-slot remains unsyllabified and neither triggers V-Epenthesis. When /C/ in /hC/ is a sonorant, however, only /h/ may be syllabified with a preceding vowel. Because an unstressable vowel is not associated with a V-slot, a sonorant consonant in an /hC/ cluster remains unsyllabified before it, V-Epenthesis is applicable, and the floating vowel receives a V-slot, becoming stressable. Only /hl/ receives this treatment because only /hl/ is ever followed by an unstressable vowel in underlying forms. This is an important result, since the special status of /hC/ clusters and the apparently anomalous position of /hl/ were left unexplained under the metrical account of stressability developed in the last section.

Despite this success, we have not yet accounted for the full range of cluster effects. Certain cases involving /s/ remain problematic. If the two special rules for the syllabification of /s/, (105a) and (105b) above, are allowed to apply at the same point in derivations as our other rules of syllabification, we will incorrectly predict that /s/ should be able to remain unstressable after /Cs/ clusters.

Consider, for example, the word aps-əkil (small-size-(3)) 'he is small.' The /ps/ of aps- is presumably an underlying cluster, since it does not alternate with any other sequence.

The /ə/ of /-əkil-/ must be underlyingly unstresable, since it undergoes syncope in forms like kín-kil (large-size-(3)) -'he is big.' Thus the underlying form of ápsəkíl will be (121), ignoring the suffix /-w/ as before.

(121) V C C    C V C  
       | | |    | | |  
       a p s ə k i l

Now let us suppose for the moment that the only syllabification rules are those of (104): a syllable may contain one initial and/or one final consonant. The representation in (121) will then be syllabified as (122).

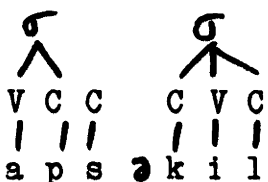
(122)   
       V C C    C V C  
       | | |    | | |  
       a p s ə k i l

If this structure is the input to V-Epenthesis, the result will be (123a). Stress assignment and stress subordination will then give (123b): ápsəkíl, just like póhtáyak.

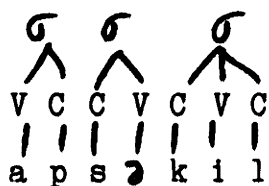
(123) a.   
       V C C V C V C  
       | | | | | | |  
       a p s ə k i l

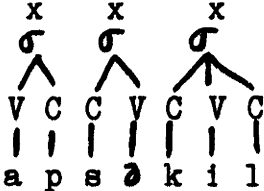
b.            x  
               x    x  
  
               x    x    x  
                 
       V C C V C V C  
       | | | | | | |  
       a p s ə k i l

Things seem to go wrong, however, as soon as we take the rules of (105) into account. Given (124a), the output of the rules for CVC syllables, both (105a) and (105b) are potentially applicable. If we apply (105a), we will derive (124b). If we apply (105b) instead, we obtain (124c).

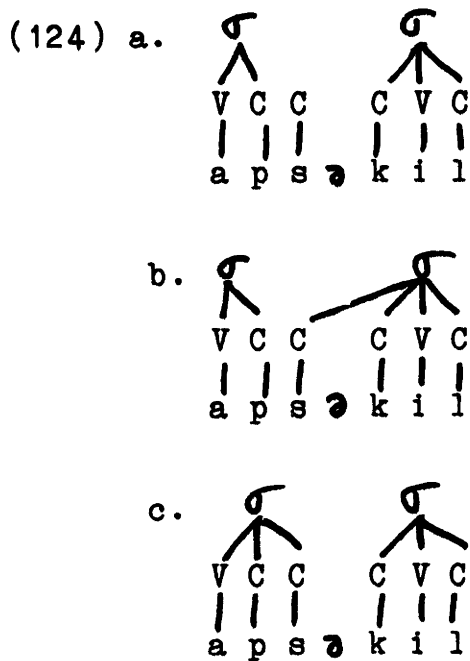

In either case, no C-slot remains unsyllabified to trigger V-Epenthesis. Since unstressable /ə/ regularly undergoes syncope in /-əkil-/ 'be a size,' both derivations yield incorrect \*ápskil.

But there is an easy way to avoid this dilemma: delay the application of the rules which provide for the syllables with the shapes /sCV/ and /VCs/ until after the application of V-Epenthesis. This will leave of /s/ unsyllabified at the point in derivations when V-Epenthesis is applicable unless it (1) immediately precedes or immediately follows a (stressable) vowel, where (104a,b) will incorporate it into a syllable, or (2) follows a /Vh/ sequence, where it will be syllabified by (120)

instead. Ordering (105a,b) after V-Epenthesis thus predicts that all clusters of /s/ and another nonsyllabic, with the exception of /hs/, should pattern with non-laryngeal clusters like /ck/ in their effects on underlyingly unstressable /ə/. This is just the right result.

The syllabification rules of (104), which create basic CVC syllables, and rule (120), which sanctions syllable-final h-obstruent clusters, must be allowed to precede V-Epenthesis. Yet we have already seen that at least (104a) must also be applicable after V-Epenthesis, since it must incorporate the C-slot which triggers epenthesis into the syllable which is introduced with the inserted V-slot. The special rules for /s/, on the other hand, must not be applied before V-Epenthesis. To account for these ordering relationships, I propose that the syllabification rules of Passamaquoddy are in fact divided into two sets as follows, and that the rules of the two sets are different in character. The rules of the first set, which I call "basic syllabification," apply throughout derivations whenever their structural descriptions are met. Those of the second set are applicable only late in derivations, after the application of all rules inserting epenthetic V (and perhaps apply only once).

(125) Basic Syllabification

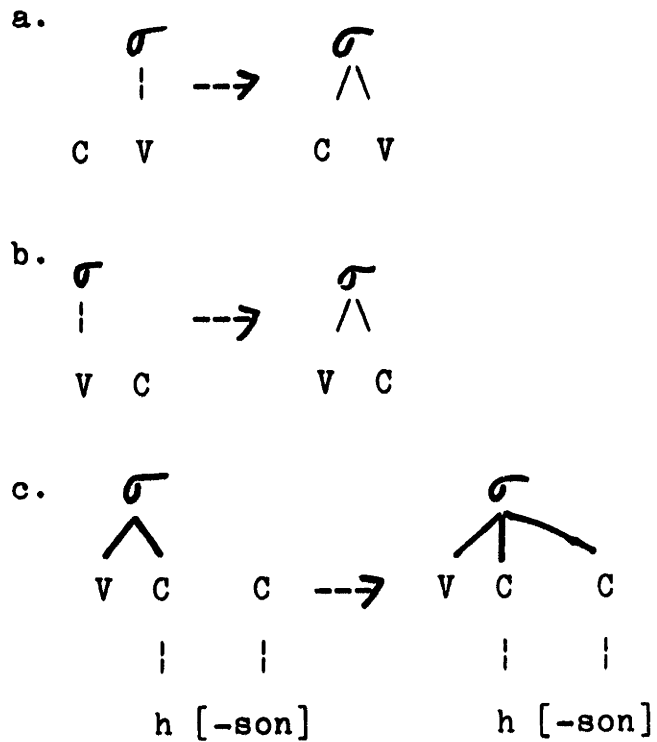

(126) Adjunctions of /s/

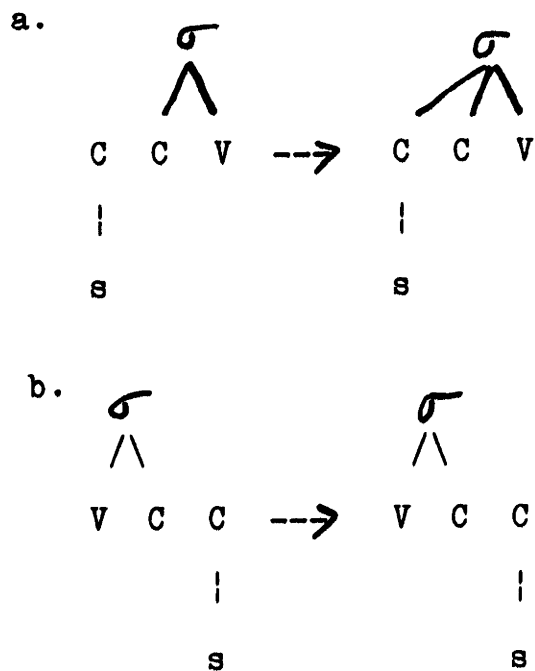

As before, (a) takes precedence over the other rules in either set and the rules in (125) take precedence over those in (126).

The consequences of this system of assumptions will become clear when we look at the role of V-Epenthesis in alternating stressability in 4.5.6.

#### 4.5.5 Final Syllable Epenthesis

The  $\sigma$  of sítəm 'shore' must be underlyingly unstressable, since we find unstressable ə in sítəm-ək 'shore (loc.)'. Thus the hypothesis that unstressable /ə/ is floating /ə/ requires us to postulate (127) as the underlying form of the former.

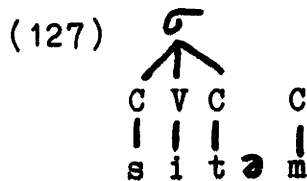

Since the C-slot associated with /t/ in (127) is syllabified, V-Epenthesis is not applicable here. Thus there is nothing in the CV theory of stressability as we have developed it to this point which will account for generalization (18a): /ə/ is always stressable when it is the last vowel of a word. To express this generalization, we must postulate an additional rule, which I call Final Syllable Epenthesis:<sup>14</sup>

#### (128) Final Syllable Epenthesis

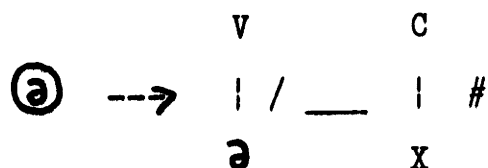

Here again the use of the variable  $\underline{X}$  is required to state the relative positions of floating /ə/ and the following C. In Chapter 6 I will argue that (128) should be generalized to apply to floating vowels other than /ə/. The generalized rule must be able to apply before final clusters of the form /hC/, but there do not appear to be any cases in which a floating /ə/ which triggers the rule is followed by more than a single non-syllabic element.

Final Syllable Epenthesis will convert (127) to (129), given the assumption that the basic syllabification rules are applicable throughout derivations.

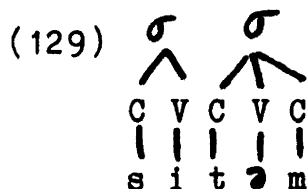

In just the same way, Final Syllable Epenthesis will convert (130a) to (130b) in the derivation of tóhsán-ək 'shed (loc.).'

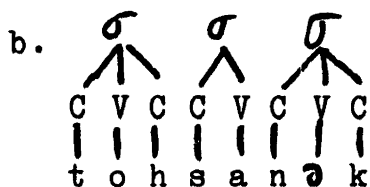
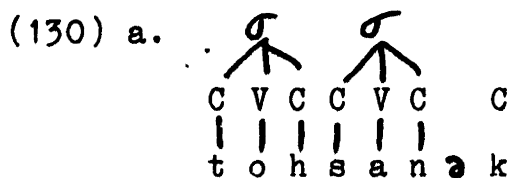

Since the syllable which it creates always figures into the "count" which determines stress placement, Final Syllable Epenthesis, like V-Epenthesis, must precede stress assignment.



Which of these two epenthesis rules should be considered to be applicable is indeterminate in certain cases. Given the representation of sita<sup>ˈ</sup>m-ək 'shore (loc.)' shown in (131a), either rule will give (131b).

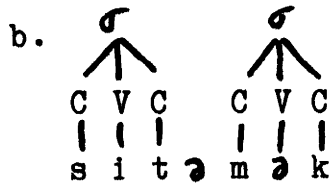
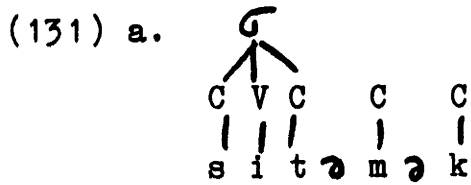

For expository convenience, I will assume that Final Syllable Epenthesis precedes V-Epenthesis, so that (131b) is derived by the former. The derivation is completed by the application of the stress rules, followed by Schwa Support and resyllabification, giving (132).

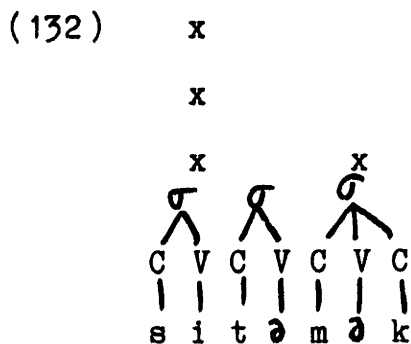

Final Syllable Epenthesis always has the effect of making an unsyllabifiable consonant syllabifiable, but the rule need not be stated to make specific reference to C'. The rule cannot be reformulated, however, to make to apply without regard to the presence of a floating vowel. An epenthetic V-slot is not

inserted, for example, in the derivation of n-ítkw (1-eyebrow) 'my eyebrow,' despite the fact that the final consonant of this word cannot be incorporated into a syllable by the basic syllabification rules.

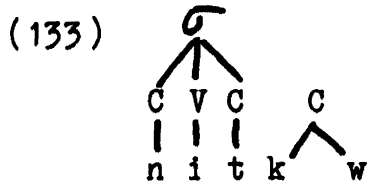

#### 4.5.6 Alternating stressability

If we consistently represent underlyingly unstressable /ə/ as a floating vowel, then the underlying representations of many words will contain sequences of unsyllabifiable C-slots, sometimes quite long ones. The underlying form of ásəw-əcək-po (oblique-messy-sit-(3)) 'it (an.) is flopped over to one side' is /asəw-əcək-əpi-w/. Underlying /i/ becomes unstressable /ə/ by the rule of I-Mutation, which will be motivated in 4.6. In the output of this rule, ásəwəcəkəpo is represented as follows.

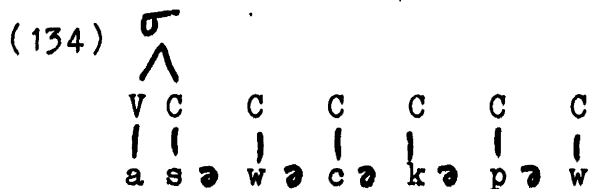

Only one C-slot is syllabified in this representation, although the application of Final Syllable Epenthesis will convert (134) into a structure in which two more C-slots can be syllabified, as shown in (135).

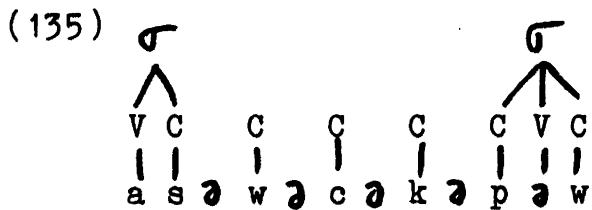

Three C-slots remain unsyllabified in this representation and are thus potential triggers of V-Epenthesis. In principle, there are a variety of ways in which this rule might be applied. Let us suppose, however, that the rule applies first as far to the left in the word as possible. The result will be (136a). But we have proposed that the basic syllolabification rules apply throughout derivations whenever their structural descriptions are met. Thus (136a) will immediately be syllabified as shown in (136b).

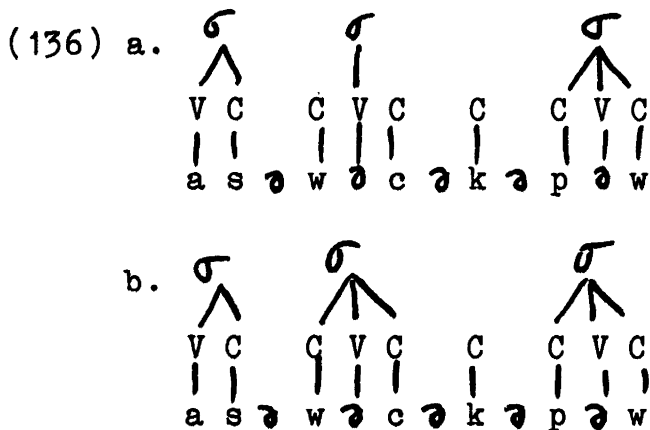

Although the C' associated with the /w/ of /asəw-/ was the trigger of this application of V-Epenthesis, both this C' and that associated with the /c/ of /-əkək-/ are syllabified in the output of the rule.

Suppose, now, that V-Epenthesis is allowed to apply again -- in other words, that the rule applies iteratively, from left to right. The C associated with the /c/ of /-əkək-/ is no longer



Word-final / w/ surfaces as o, and the result is ásawacakápo, stressed as required.

This derivation suggests how iterative application of V-Epenthesis can be used to account for alternating stressability. A series of unstressable schwas is a series of floating vowels. Because these vowels lack V-slots, the consonants which come between them cannot be syllabified. But each application of V-Epenthesis permits the syllabification of two of these consonants. Allowing the basic syllabification rules to reapply throughout derivations has the effect that each application of V-Epenthesis eliminates the next following C' as a potential trigger of the rule:

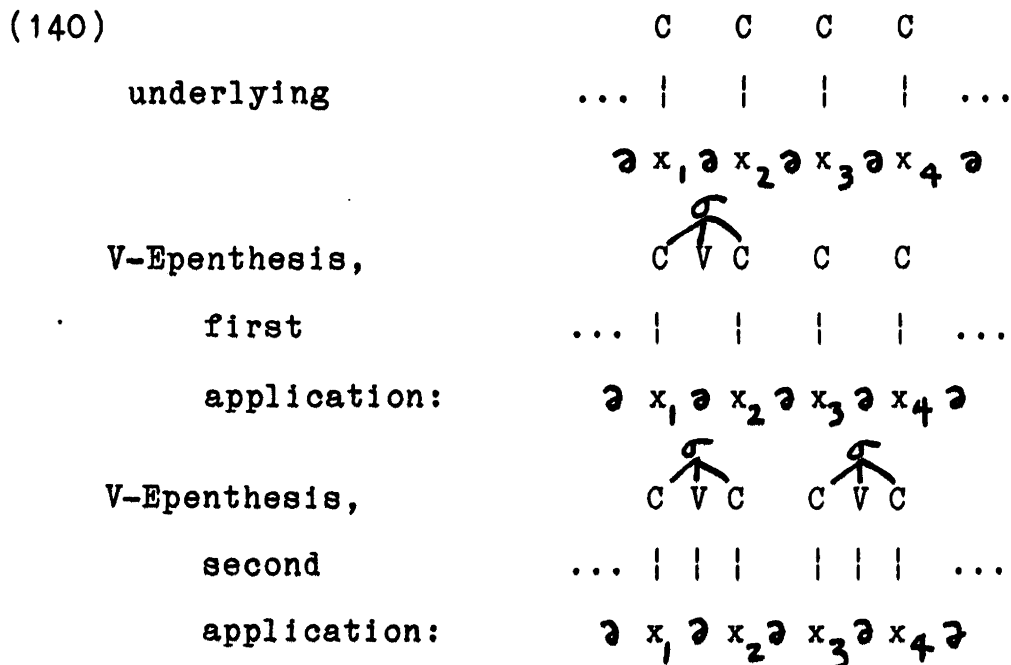

The result is that every other floating /ə/ receives a V-slot: alternating stressability.

Now this analysis of alternating stressability requires us to postulate the directional, iterative application of V-Epenthesis, a non-metrical rule. Notice, however, that there is

no need in this analysis to establish an explicit pairing of schwas, or even to mention more than one /ə/ in the rule which creates alternating patterns of stressability. The effect of counting off schwas by pairs is achieved indirectly, by linking C positions to syllable nodes two at a time. This linking is not accomplished by V-Epenthesis, however, but by the basic syllabification rules.

Because V-Epenthesis is the mechanism of alternating stressability in this account, no additional provisions are required to introduce the effects of various types of consonant clusters in determining where alternation begins. In this connection, we may compare the derivations of h-péhk-ən-əm- n 'he takes it all' and h-pásk-ən-əm-ən 'he breaks it with his hand.'

The syllabified underlying form of hpéhkənəmən is shown in (141a). The application of Final Syllable Epenthesis gives (141b).

(141) a.



b.

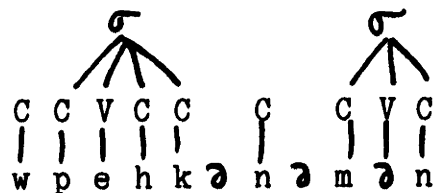

One potential trigger of V-Epenthesis remains, the /n/ of /-ən-/ 'by hand.' The output of the rule, after syllabification, is (142).

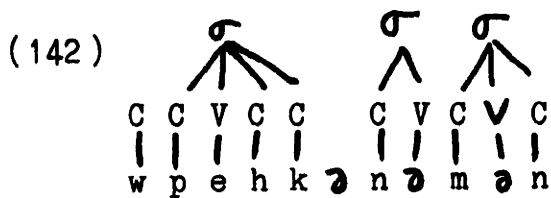

Here the /ə/ of /-ən-/ remains unstressable, while that of the TI element /-əm-/ is stressable, as the principle of alternating stressability demands. Stress is assigned to the penultimate and initial syllables in (142) correctly giving us hpéhkanámən.

The syllabified underlying form of hpáskánámən is (143a). Again Final Syllable Epenthesis is applicable. Its output is syllabified as shown in (143b).

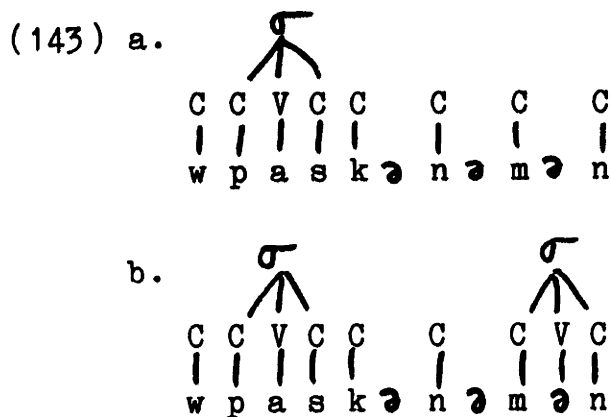

This time there are two potential triggers of V-Epenthesis. The one on the left is the C associated with the /k/ of /pask-/ 'break.' The output of V-Epenthesis and syllabification is (144).

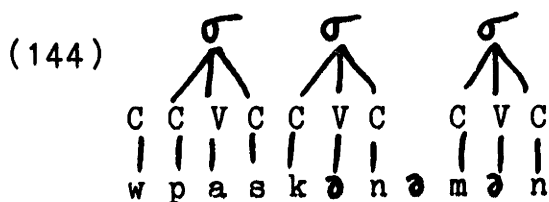

Since the /n/ of /-ən-/ is now syllabified, it is no longer available to trigger epenthesis. The /ə/ of /-əm-/ therefore

remains unstressable here. The result is what we described in 4.2. by saying that the /ə/ of /-əɾ-/ is taken "out of the count" in determining alternating stressability because it follows the cluster /sk/ of /pask-/. The /ə/ of /-əɱ-/ is then left in "first position" position in a series of schwas within which alternating stressability holds. From the perspective of the CV theory of stressability, a /ə/ is in an odd-numbered position in such a series if the preceding C-slot is not a trigger of V-Epenthesis. Because the /ə/ of /-əɱ-/ remains a floating vowel when stress is assigned, it is "skipped over" by the ASR, which assigns stress to the syllable /k n/ as the penultimate syllable in (144). The result, correctly, is hpáskə́nəɱən.

#### 4.5.7 Extrametricality

The preceding discussion has raised the possibility of reducing alternating stressability and the effects of clusters on stressability to a single principle, V-Epenthesis. As we have seen, the proposed rule has the right consequences where potential triggers are medial in a word. Cases involving word-initial consonant clusters present a problem, however.

The first syllable of pə́mí-ph-â (along-carry-3PASS) 'he is carried along' is unstressed. By hypothesis, the /ə/ of /pəɱ-/ must be a floating vowel at the point in the derivation of this word when stress is assigned. The first /ə/ of underlying /məs-ə́n-əɱ-/ is subject to syncope in ps-ə́n-əɱ-ə́n (get-by.hand-TI-2-(SUBJ)) 'if you (sg.) get it.' Thus this /ə/, too, must remain unstressable. In both words, a word-initial unsyllabified



consonant is followed by a floating /ə/ but fails to trigger V-Epenthesis.

The syllabified underlying representation of pəmíphâ is shown in (145). Compare the underlying representation of h-pəmí-ph-a-l (3-along-carry-DIR-3.OBV) 'he carries the other along' in (146). Here the /p/ of /pəm-/ must be assumed to trigger V-Epenthesis, giving (146b), since the first syllable of this word is stressed.

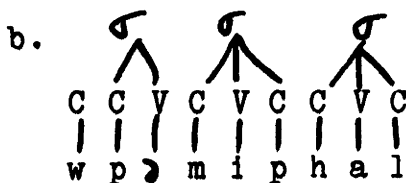
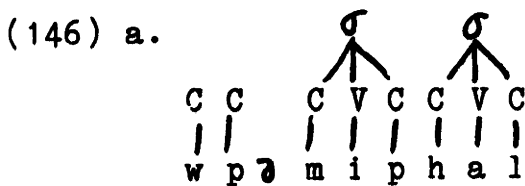
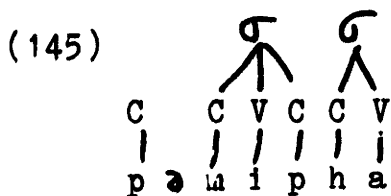

An unsyllabified /p/ in a word-initial cluster must also be taken to trigger V-Epenthesis in the derivation of sp-ápo (high-sit-(3)) 'he sits up high' for those speakers who have reanalyzed /asp-/ 'up high' as /sp-/. For these speakers, the output of Final Syllable Epenthesis in the derivation of sp-ápo is (147a). V-Epenthesis derives (147b).

(147) a.

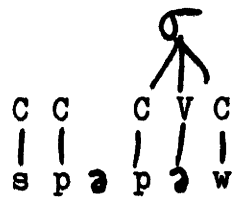

b.

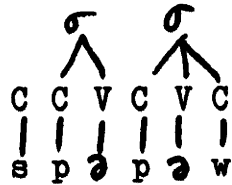

Why should unsyllabified /p/ trigger V-Epenthesis here and in (146), but not in (145)?

What distinguishes the unsyllabified /p/ of (145) is simply the fact that it is initial in the word: unstressable /ə/ becomes stressable after a word-initial cluster but not after a single word-initial C. In the terms of the CV theory of stressability, this means that word-initial C' must be excluded as a trigger of V-Epenthesis.

We can certainly obtain this result by complicating our statement of V-Epenthesis. Using angled brackets, we could formulate the rule as in (148).

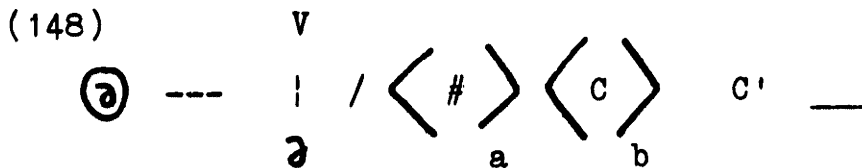

Condition: a implies b.

But of course such a formulation simply stipulates a property of the epenthesis process which we would prefer to explain. A more promising approach makes use of the concept of extrametricality.

Following Liberman and Prince (1977), Hayes (1980, 1982), Harris (1983), and Selkirk (1984), I assume that a single constituent (segment, syllable, etc.) may be designated as extrametrical within a particular domain if it occurs at the left or right margin of that domain. For Passamaquoddy, let us suppose that word-initial extrasyllabic C's are uniformly designated as extrametrical. (I will indicate extrametricality by means of parentheses.)

(149) Extrametricality

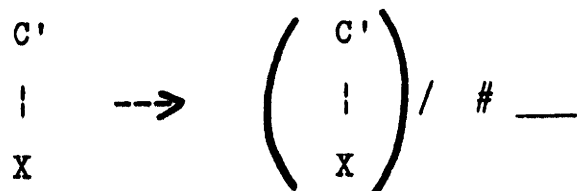

In the case of pamíphá and hpámíphal, the results are as follows.

(150) a.

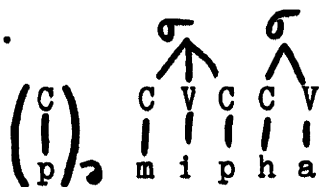

b.

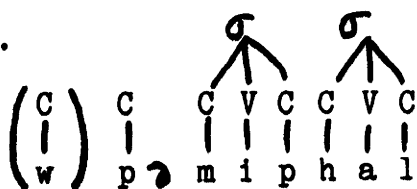

By convention, an extrametrical constituent can neither block nor trigger any phonological rule. Thus the /p/ of /pəm-/ is excluded as a trigger of V-Epenthesis in (150a). The /ə/ which following this segment remains a floating vowel when stress is assigned. Eventually this /ə/ receives a V-slot by Schwa Support, since it is not subject to syncope. Word-intial /p/

will be syllabified with this /ə/ at the phrase level, since /p/ is extrametrical only on the word domain.

In (150b), it is the prefix consonant which is designated as extrametrical. Because the /p/ of /pəm-/ is not initial in this word, it remains accessible to phonological rules. In particular, it is available to trigger V-Epenthesis.

Consider, now, the underlying representation of təli-təwiye (ongoing-fly-(3)) 'he is flying,' shown in (151). (I am again ignoring the suffix /-w/, which in this case is responsible for triggering a morphologically governed rule which changes the /a/ of underlying /-t wiya-/ 'fly' to /e/.)

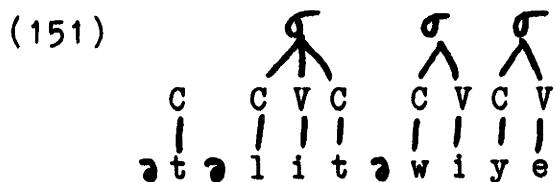

Since the C-slot associated with the /t/ of /ətəl-/ is word-initial on the CV tier, we might expect this element to be designated as extrametrical here. The constituent which consists of this C-slot and the associated segment is not marginal on all tiers, however, since it is preceded by a floating /ə/ on the segmental tier. The requirement that extrametrical constituents be peripheral thus makes it impossible to formulate (149) in such a way that it would assign extrametricality in this case. This is a desirable result, since we must assume that V-Epenthesis converts (151) to (152) in order to account for the observed stress pattern of təlītəwiye. (Initial /ə/ remains unstressable in this word and is subject to syncope.)

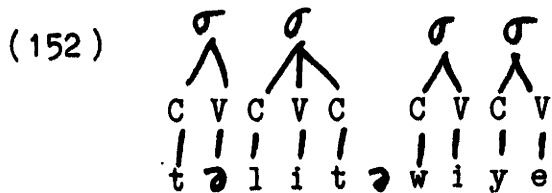

Now it is a striking fact that eliminating word-initial C' as a trigger of V-Epenthesis allows a consonant to remain unsyllabified just where an unsyllabified C-slot is permitted in surface forms by the Unsyllabified Consonant Filter, repeated here as (153).

(153) Unsyllabified Consonant Filter

\* # X C' Y #

unless X or Y is null.

Furthermore, if word-initial C' is extrametrical, then this statement of the UCF is more complicated than it needs to be. No provision for word-initial unsyllabified C is required in the statement of the filter: as a rule which is applicable on the word domain, the filter will not in any case be sensitive to the presence of initial C'. In fact, if we could designate all occurrences of word-final C' as extrametrical as well, then we could simply restate the UCF as (154).

(154) Unsyllabified Consonant Filter (revised)

\* # ... C' ... #

The special status of peripheral C' with respect to V-Epenthesis and the UCF would be reduced to extrametricality in both cases.

It is not clear, however, that assuming final-consonant extrametricality is consistent with other aspects of Passamaquoddy phonology. The rule which inserts epenthetic /ə/ on the segmental tier (Chapter 7) must have access to word-final C' in certain suffixes. Moreover, final C which cannot be syllabified by the rules that we have been operating with arise in the course of derivations through the application of Final Vowel Deletion (Chapter 10). In view of these problems, it seems better not to suppose that word-final C' is designated as extrametrical.

There is, however, another way in which we can reduce the UCF to (154). Suppose that a word-final C which remains unsyllabified after the application of other word-level rules is subject to a late rule which incorporates it into the last syllable of the word.<sup>15</sup> This rule would have the same effect as final-consonant extrametricality as far as the UCF is concerned: it would eliminate word-final C' in the structures subject to the filter. Such a rule would also make it possible to give a simpler account of the reduction of word-initial clusters which was noted in 4.5.3. Instead of stating a rule which deletes word-initial C', we can simply say that C' is subject to deletion wherever it occurs (presumably at the phrase level, where word-initial C' will no longer be extrametrical).

I will tentatively adopt this proposal here. Thus I will assume that the UCF may be stated as in (154), even though we do not have a rule which will designate word-final C' as extrametrical. I will assume that word-initial C' is extrametrical, however, so that no change in the statement of V-

Epenthesis is required in order to account for the fact that single word-initial consonants do not trigger the rule.

#### 4.5.8 S-HS Epenthesis

Neither V-Epenthesis nor Final Syllable Epenthesis will insure that /ə/ is always stressable between /s/ and /hs/. This fact requires an independent stipulation in any of the frameworks that we have been considering. This stipulation can be stated in CV terms as a third rule inserting V:

(155) S-HS Epenthesis

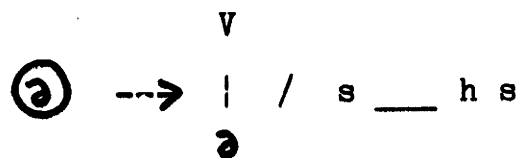

I assume that S-HS Epenthesis should be formulated as a rule which "supports" certain occurrences of /ə/ because this rule, like our other proposed rules of V-slot epenthesis, only inserts V in positions in which a floating /ə/ can be motivated on other grounds. (In any case, we will see in 6.4 that S-HS Epenthesis must not be applicable where /s/ and /hs/ are separated by a floating /a/.) All of the schwas for which S-HS Epenthesis provides slots are epenthetic. See Chapter 7 for the argument that epenthetic schwas are inserted on the segmental tier prior to the insertion of slots on the CV tier for some of them.

S-HS Epenthesis will convert (156a) to (156b) in the derivation of skənís-əss-is (bone-DIM-DIM) 'bone (dim.).'

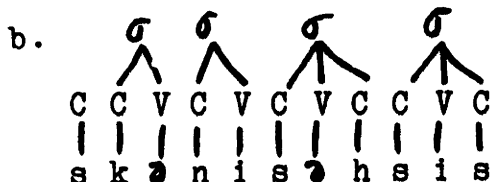
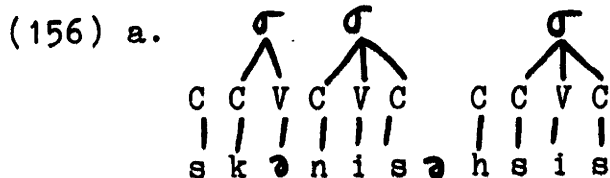

The resulting structure is appropriate to serve as the input to stress assignment. H-Deletion I and the leftward spreading of /s/ onto the C position which this deletion leaves vacant will then complete the derivation of skənissəhsiss.

#### 4.5.9 Schwa in word-initial /(C)ə [+sonorant] ə/

Only one of the generalizations of (18) remains to be stated in CV terms: the fact that the first /ə/ in word-initial /(C)ə [+sonorant] ə/ is always stressable if the second /ə/ is not. Both of the previous formulations of this generalization that we have attempted have had to mention the two vowels in this environment explicitly. Moreover, one required us to write a diacritic in a diacritically specified environment, while the second involved a comparable manipulation of accents, raising the question of how the power admitted into linguistic description by the use of such devices can be constrained. The CV theory of stressability can handle this case with a rule which mentions only one vowel and makes no reference to diacritic features or to accents. I call this rule Initial Syllable Epenthesis.



When both schwas in word-initial / (C)ə [+sonorant]ə / are unstressable, neither the first C in this sequence (if any) nor the non-syllabic sonorant which stands between the two schwas is syllabifiable. The underlying form of pám-əka (along-dance-(3)) illustrates this point:

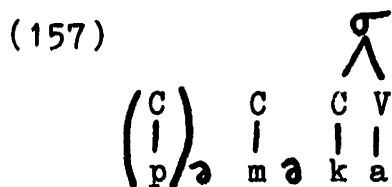

Since the initial C' of a word like this will be designated as extrametrical, we can simply ignore it in formulating Initial Syllable Epenthesis. We can pick out the class of cases in which a sonorant stands between unstressable vowels by specifying that this segment is unsyllabified:

(158) Initial Syllable Epenthesis

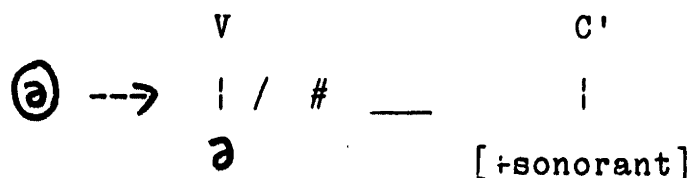

Initial Syllable Epenthesis will derive (159a) from (157). Stress assignment, Schwa Support, and phrase-level syllabification will then give (159b) from (159a).

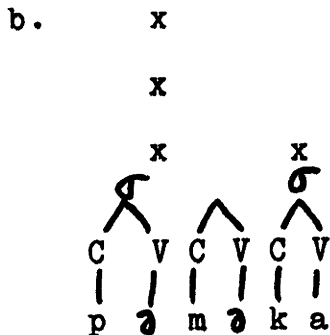
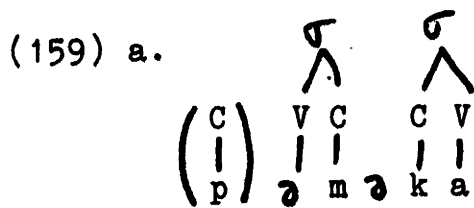

Initial Syllable Epenthesis is not applicable in a word in which the second /ə/ in initial /(C) ə[+sonorant]ə/ is stressable, because the non-syllabic sonorant in the sequence will be syllabified in any such form. Consider, for example, the word ləkwtəwəkən 'article of clothing,' the variant form of ələkwtəwəkən in which the second /ə/ in underlying /ələkwtəwəkən/ is inherently stressable. Because this stressable /ə/ is associated with a V-slot, /l/ is syllabified in this word in the input to Initial Syllable Epenthesis:

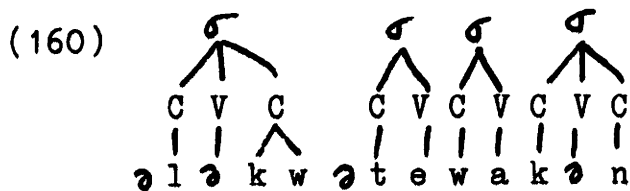

Since there is no unsyllabified C-slot in this representation, Initial Syllable Epenthesis is simply not applicable. No explicit mention of the status of the second /ə/ of the word is needed to produce this result. Both floating schwas in (160) are ultimately subject to syncope.

As we noted in 4.2.4, the first /ə/ in word-initial /-(C)ə[+sonorant]ə/ must be excluded from a series of -schwas within which alternating stressability is figured. This fact can be accounted for by ordering Initial Syllable Epenthesis before V-Epenthesis. Given this ordering, the derivation of əl-ən-əm-əw-a-t (thus-by.hand-TI-TA-DIR-3AN) 'he hands it to the other' proceeds as follows. The syllabified underlying form is (161a). Initial Syllable Epenthesis gives (161b). V-Epenthesis derives (161c). Stress assignment and Schwa Support then yield (161d), the correct surface representation for this word.

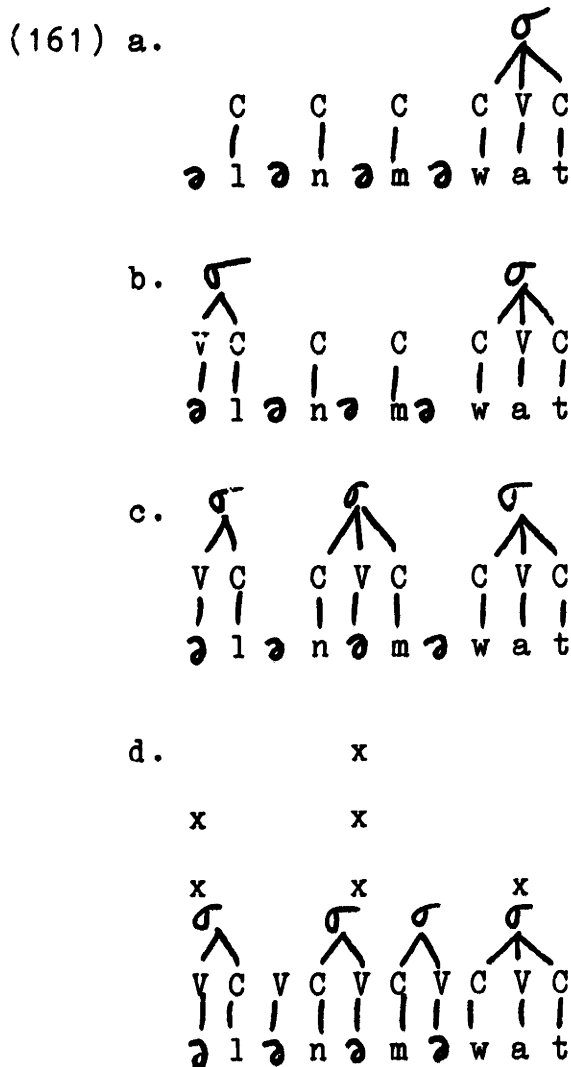

Initial Syllable Epenthesis sets up the input representations for V-Epenthesis in this account just as accent assignment sets up the input to Subfoot Formation in the metrical theory of 4.4.

#### 4.5.10 Inherently stressable /ə/

Inherently stressable /ə/ can also be accommodated within the CV theory without the use of diacritics or accents: an inherently stressable /ə/ is simply a /ə/ which is associated with a V-slot in underlying representations. The root /kətəw-/ 'want' provides an example, since the first /ə/ of this morpheme is always treated as stressable. On the assumption that this segment is underlyingly associated with a V-slot, the syllabified underlying form of kətəw-i-təw-iye (want-fly-(3)) 'he wants to fly' will be as shown in (162).

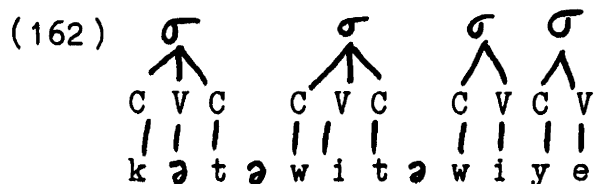

Neither V-Epenthesis nor any of the other rules inserting epenthetic V is applicable here, so (162) is the input to stress assignment, giving (163a). Schwa Support and resyllabification then give (163b), the correct surface representation for kətəw-i-təw-iye.

(163) a.

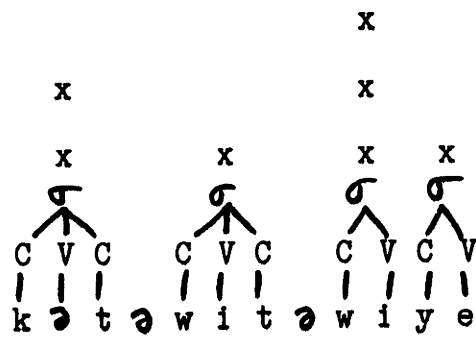

b.

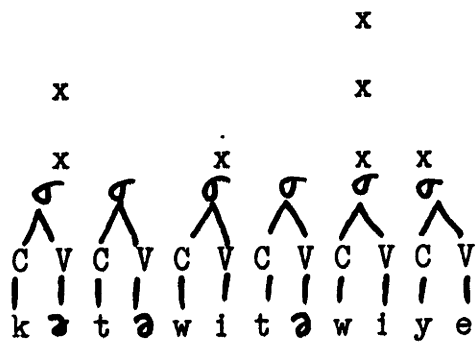

The fact that inherently stressable schwas are excluded from sequences within which alternating stressability holds follows immediately if these vowels are associated with V-slots in underlying representations. Consider, for example, the word kətəw-ələn (want-rain-(3)) 'it is going to rain,' where the underlyingly unstressable /ə/ of /-ələn-/ 'rain' becomes stressable because it is the second /ə/ after the inherently stressable /ə/ of /kətəw-/. Given the underlying representation shown in (164a), the /w/ of /kətəw-/ will serve as a trigger from V-Epenthesis, which gives (164b). The /ə/ of /-ələn-/ thus makes a syllable which is available for stress assignment here, just as it does in písk-ələn 'it rains so hard that it is dark or hard to see.'

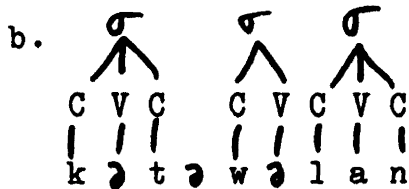
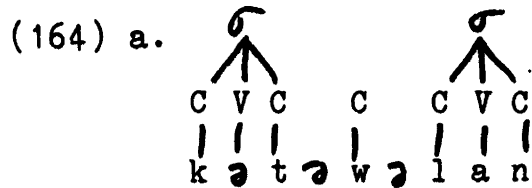

#### 4.5.11 Strengths and weaknesses of the CV theory

The rules which I have proposed above to account for the generalizations of (18) within the CV theory of stressability are summarized in (165).

(165) a. /ə/ is stressable when it is the last vowel of a word by Final Syllable Epenthesis:

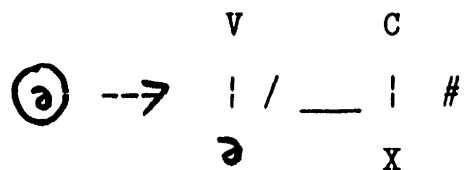

b. /ə/ is stressable after clusters other than /nC/ by V-Epenthesis:

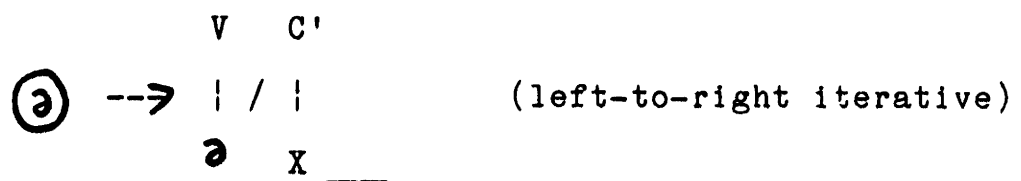

c. /ə/ after /hl/: also stressable by V-Epenthesis

d. /ə/ is stressable between /s/ and /hs/  
by S-HS Epenthesis:

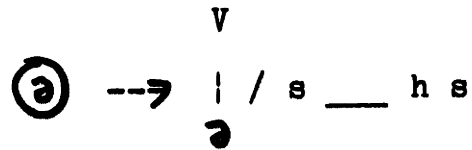

e. The first /ə/ in word-initial /((C)ə [+sonorant] ə/  
is stressable (when the second is not) by  
Initial Syllable Epenthesis:

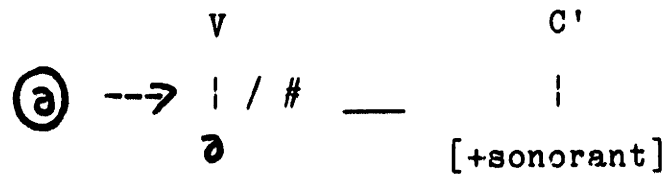

f. alternating stressability: follows <sup>from</sup> the interaction  
of V-Epenthesis and the basic syllabification  
rules

The diacritic theory requires six rules and the metrical theory five to do what is here accomplished by four. In this sense, the CV theory permits a simpler statement of the conditions governing stressability than either of the alternative accounts that we have considered.

The rules of (165) are not the only devices that we have invoked in the CV theory of stressability, however. We have also made extensive use of a system of syllabification rules, proposed a rule which makes word-initial C' extrametrical, and postulated the rule of Schwa Support to insure that unstressable schwas which remain in surface forms after the application of the

syncope rules are linked to positions on the CV tier. The syllabification rules are for the most part independently motivated by distributional considerations (although the division of these rules into two sets with different ordering properties is not). The extrametricality of word-initial C' may have independent justification in the simplification of the Unsyllabified Consonant Filter to which it contributes. The rule of Schwa Support is only required, however, because we have hypothesized that unstressable schwas lack V-slots in underlying representations. It is not obvious, therefore, that the CV theory is preferable to the metrical theory on the grounds of simplicity alone.

Moreover these two approaches lead us to different conclusions about what groupings of the descriptive statements in (18) can be subsumed under broader generalizations. From the point of view of the metrical theory, the fact that /ə/ is stressable in word-final syllables follows automatically from the procedure by which alternating stressability is assigned, the rule of Subfoot Formation. In the CV theory, alternating stressability instead falls together with the effects of various clusters: both sets of phenomena follow from the fact that V-Epenthesis inserts a V-slot after an unsyllabified consonant. Cluster effect require special accent assignment rules in the metrical theory; the status of /ə/ in final syllables requires a special rule in the CV account. Since these theories make different claims about what should be counted as a generalization, it is important to see whether there are



considerations other than overall simplicity which can be used to decide between them.

One important consideration which favors the CV theory over either of its competitors is the fact that it allows us to distinguish between stressable and unstressable vowels without introducing any device solely for this purpose. CV phonology postulates a system of distinct tiers, including a timing tier and a segmental tier. The possibility that elements of the segmental tier may not always be matched by elements of the timing tier is implicit in the claim that these tiers are autonomous. By exploiting this possibility, we not only provide a structural basis for the distinction between stressable and unstressable vowels, but give unstressable vowels a representation from which their treatment in stress assignment follows automatically. If stress is assigned on the basis of vowel projections, then unstressable vowels will not be stressed because they will not be projected. If stress is instead assigned to syllables, unstressable vowels will still remain invisible, since rules of syllabification organize the elements of the timing tier.

Of course there is also an intrinsic difference between accented and unaccented vowels which insures that they will receive different treatment in the assigning metrical structure. Yet the claim that the stressable/unstressable distinction reflects a process of metrical structure assignment is seriously undermined by the fact that the majority of vowels in most words must be marked -- either lexically or by rule -- to prevent them from undergoing Subfoot Formation "regularly."

In any account of stressability, we are going to have to make some set of stipulations in underlying forms to distinguish between inherently stressable vowels and underlyingly unstressable vowels. In the metrical theory, we make this distinction by marking all inherently stressable vowels with accents. But this seems inappropriate, as we noted in 4.4.7, since it requires us to stipulate the behavior of those vowels whose treatment in stress assignment should clearly be viewed as the unmarked case. In the CV theory, it is precisely the marked cases -- underlyingly unstressable vowels -- whose status must be stipulated. Since the unmarked situation is one in which every segment is associated with a timing slot, we do not need to make any special stipulations to account for the status of inherently stressable vowels. Rather, it is the underlyingly unstressable vowels whose marked status must be stipulated in underlying forms.

Note, too, that this approach will allow us to view paradigm leveling as a process which reduces the number of stipulated properties of underlying forms. An underlying form which contains an inherently stressable vowel is less marked than a corresponding representation with an underlyingly unstressable vowel, if we adopt the CV analysis of stressability. We therefore predict, correctly, that linguistic change will result in the elimination of alternations in stressability. On the metrical account, this type of change is puzzling, since it involves multiplying the stipulated properties of underlying segments.

Finally, the substance of the rules needed in the CV framework makes it possible to explain some of the generalizations in (18) in ways which are not available in the other models. Accent assignment lets us state the classes of clusters after which /ə/ becomes stressable, but these statements remain essentially arbitrary. In the CV account, the status of /ə/ after non-laryngeal clusters and the seemingly anomalous treatment of /ə/ after /hl/ follow from basic principles of syllabification which are clearly reflected in the surface distributions of various types of non-sylabics. The fact that two unstressable vowels are required to trigger the special treatment of the first /ə/ in word-initial /((C)ə[+sonorant]ə/ must simply be stipulated in the diacritic and metrical accounts of stressability, but need not be explicitly stated in the rule of the CV theory which accounts for this class of cases. Thus the CV theory provides greater insight into the nature of the conditions on stressability than we obtain from either a diacritic or a metrical approach.

#### 4.6 I-Mutation

Many stems ending in /i/ are subject to a rule which replaces /i/ with /ə/ before certain suffixes beginning with /w/. It is not in general possible to predict whether a particular combination of a stem and a suffix will undergo this replacement. Not all suffixes beginning with /w/ trigger the change and some stems undergo the replacement before some trigger suffixes but not others.<sup>16</sup> In this section I want to look briefly at cases in

which "I-Mutation" is triggered by the third person Buffix /-w/ of the AI and II Independent Indicative paradigms.

We will see below that the /ə/ which results from I-Mutation may be either stressable or unstressable, following the same rules in this regard as underlyingly unstressable /ə/. This situation is easily accommodated if we assume that I-Mutation replaces stressable /i/ with unstressable /ə/ prior to the application of the rules which determine the distribution of stressable and unstressable /ə/ in the input to the stress rules. (Compare I-Backing, rule (34) of section 4.2.2, which derives stressable /ə/ from /i/.) In CV terms, the rule may be stated as follows:

(166) I-Mutation

V	ə	C	
	-->	/	___ +   (morphologically governed)
i		ə	w

Schwa which is derived in this way will be subject to the same rules of V-slot epenthesis as basic unstressable /ə/.

If I-Mutation is given a phonological statement like (166), then both the triggers and the targets of the rule must be diacritically specified. It would probably be preferable for this reason to state I-Mutation as a redundancy relation among lexical items in a word-based model of the Passamaquoddy lexicon. It is convenient, however, to discuss forms containing the suffix /-w/ in terms of a rule which changes stressable /i/ to unstressable /ə/ in the course of phonological derivations, and I

will continue to treat I-Mutation as a phonological rule for expository purposes.

Whether a particular stem undergoes I-Mutation before /-w/ depends on its final morpheme. Thus stems ending in the AI and II final /-eyi-/ are regularly subject to mutation: píhc-éy<sub>a</sub>-w-əl (long-II-3-33IN) 'they (in.) are long,' pkw-éy<sub>a</sub>-w-əl (red-II-3-33IN) 'they (in.) are red'; cf. méhkw-éyi-k (red-II-3IN) 'that (in.) which is red.' On the other hand, the AI final /-i-/ which forms verbs of possession usually does not undergo mutation: ht-ówhem-í-w (3-pet-AI-3) 'he has a pet,' máni-m-í-w-ək ((3)-money-POSS-AI-3-33PROX) 'they (du.) have money.'

As we saw in Chapter 3, a and o are, for the most part, not distinct before w. Following the convention established in 3.3, I write a consistently for unstressable vowels before w which vary phonetically from [ə] to [u]. In stressable positions, where the more rounded variants are the norm, I write o instead. Thus the surface segment which represents the output of I-Mutation is interpreted as o in əpó-w-ək (sit-3-33PROX) 'they (du.) sit' but as a in ápáté-p<sub>a</sub>-w-k (lean-sit-3-33PROX) 'they (du.) sit leaning against something'; cf. kt-ápí-pa 'you (du.) sit,' ht-ápáté-pi-n 'he sits leaning against it.'

Word-final /əw/ resulting from I-Mutation is realized simply as o: əpó (sit-(3)) 'he sits,' ápáté-po (lean-sit-(3)) 'he sits leaning against something.' This situation is plausibly interpreted as a result of the change of /ə/ to /o/ before /w/ (since /ə/ is always stressable in a word-final syllable), followed by the deletion of word-final /w/ after /o/ (since surface ow does not occur at the end of a word). The rule

responsible for this deletion can probably be identified with that which gives i for word-final /iy/, as in the derivation of nt-əlī (1-thus-(go)) 'I go there' (from /nt-əli-ya/ via /nt-əli-y/ by Final Vowel Deletion); cf. nt-əlī-ya-w (1-thus-go-NEG) 'I do not go there.'

The factors which determine whether the /ə/ derived by I-Mutation surfaces as a stressable vowel are the same as those which determine whether underlying unstressable /ə/ comes to be counted as stressable. The /ə/ from stem-final /i/ is unstressable after a stressable vowel and a single consonant in l-ákótə-w-ək (thus-related-3-33PROX) 'they (du.) are related' (cf. kt-əlákotì-pən 'we (du. inc.) are related'); but /ə/ in the output of I-Mutation is stressable, surfacing as o, after the cluster /lt/ in əp-óltó-w-ək (sit-pl-3-33PROX) 'they (pl.) sit' (cf. kt-əp-oltí-pa 'you (pl.) sit'). Schwa from I-Mutation surfaces as o in an even-numbered position governed by alternating stressability in skíci-kapə wó-w-ək (surface-stand-3-33PROX) 'they (du.) stand on the surface' and kəlól-tó-w-ək (argue-RECIP-3-33PROX) 'they (du.) argue with each other' (earlier /kəlól-ətə-w-ək/). (For stem-final /i/ in these forms, compare n-óskicí-kapəwì-p n 'we (du. exc.) stand on the surface' and h-kəlól-tí-ni-ya-l 'he argues with the other.')

Schwa from I-Mutation surfaces as unstressable ə in an odd-numbered position governed by alternating stressability in ksələm-ətə-w-ək (like-RECIP-3-33PROX) 'they (du.) like each other,' from /kəsələm-əti-w-ək/. Word-final /əw/ resulting from I-Mutation consistently figures into the syllable counts which determine stress placement, as we would expect.

In 5.7 we will see that unstressable /ə/ is subject to syncope between identical non-syllabics. By this test, ə in the output of I-Mutation must be an unstressable vowel: the stem-final /i/ of n-kówi-pən 'we (du. exc.) sleep' is replaced by /ə/ and ultimately deleted in ków-w-ək 'they (du.) sleep' and ków-w-à 'he (abs.) has gone to sleep.'

Irregularly, the AI plural finals -hti-, -ahti-, and -ohti- have stressable o before the third person suffix, even though unstressable \_ is expected after ht: htáma-htó-w-ək 'they (pl.) smoke' (singular htáma, htáme from stem /watama-/), séhk-ahtó-w-ək 'they (pl.) stand' (singular séhke from stem /sehke-/), əp-óhtó-w-ək 'they (pl.) sit' (singular əpó from stem /əpi-/). These finals have i in non-mutating environments, as shown by k-ótama-htí-pa 'you (pl.) smoke,' kt-əp-ohtí-pa 'you (pl.) sit.'

The historical explanation for these anomolous cases of mutation is clear: hti in the plural finals continues earlier \*həti. In fact -həti- remains as a plural final, one of the regular options for stems ending in /e/, which drop this vowel when -həti- is added: páshákwe 'he collects wood for crafts,' plural páshakw-hətə-w-ək. If the distribution of the various plural finals continued to be phonologically predictable, we would undoubtedly want to derive hti from /həti/ in a synchronic analysis of these elements. (This is in fact the approach that Sherwood takes (1983b:21-22, 167).) But the original distribution of these morphemes has been obscured by a wealth of new formations. Indeed the forms htáma-htó-w-ək 'they (pl.) smoke' and séhk-ahtó-w-ək 'they (pl.) stand' are innovations which now coexist with the historically expected forms htám-hət -

w-ək and sék-hətə-w-ək. The verb áme 'he fishes' has not only the synchronically regular plurals ám-hətə-w-ək and ám-ahtó-w-ək, but also (for some speakers) the irregular plural ám-ohtó-w-ək. Other irregular or analogical forms abound. Thus it seems better, from a synchronic point of view, to treat -hti-, -ahti-, and -ohti- as nonderived forms with irregular treatment in I-Mutation. (The allomorphs under I-Mutation should probably be analyzed as /-htə-/, /-ahtə-/, and /-ohtə-/ with inherently stressable /ə/. We would expect long o from underlying /o/ before /w/, rather than short o as observed. See 3.3 for a discussion of vowel length in this environment.)

Most AI stems in /e/ form plurals in both -ahti- and -həti-, dropping the /e/ in either case. But stems in /CCe/ other than /hCe/ usually lack plurals in -həti-. This restriction on the distribution of -həti- is reminiscent of the cluster effect in the distribution of stressable /ə/ and undoubtedly reflects the historical role of syncope in this plural formation. Synchronically, however, it is not necessary to complicate the analysis of stems in -həti- to rule out CCh clusters. This restriction follows independently from the Unsyllabified Consonant Filter, since clusters of the form CCh cannot be properly syllabified. The fact that some speakers find a few forms which violate this restriction to be marginally acceptable suggests that this is the right approach. One consultant (A.H.) gives póc-cək-p-hətə-w-ək (wet-messy-liquid-PL-3-33PROX) 'they (pl.) are soaking wet' and sómskw-hətə-w-ək (spit-PL-3-33PROX) 'they (pl.) spit' (both with [h] for h, not aspiration of the preceding stop) as variants of póc-cək-p-ahtó-w-ək and sómskw-



ahtó-w-ək (singulars póc-cək-pe, sómskwe). These appear to be cases in which analogical pressure overrides the UCF. I do not know of any comparable irregularities in clusters which are clearly derived by syncope.

#### 4.7 Stress Shift

When a word is final in an utterance, its rightmost stressed syllable is its most prominent syllable. (In the metrical theory of 4.3, in which all stressable vowels are taken to be stressed, we would say that the rightmost foot is the most prominent.) When a word or longer stress phrase is followed by other material in connected speech, however, the penultimate stressed syllable (penultimate foot) is the most prominent. The syllable which bears the greatest stress in the utterance-final form is relatively weakly stressed in the non-final form and does not correspond to a local high (or low) in the intonation contour. It might, in fact, be argued that this syllable is destressed in the non-final form, although I will assume here that some degree of stress is retained in these cases.

A few examples may help to clarify the situation. Since the word order of Passamaquoddy sentences is relatively free, the paired expressions which follow are essentially equivalent. I have indicated the location of primary stress in each word by doubling the appropriate accent mark.

(167) a. ʔləm-apasə-w-ək      was-is-ək.  
 away-pl.walk-3-33PROX child-DIM-33PROX  
 'The children (pl.) walk away.'

= b. was-is-ək ʔləm-apasə-w-ək.

(168) a. ʔlami-təwiye    cíhpəlákən.  
 away-fly-(3) eagle  
 'The eagle flew away.'

= b. cíhpəlákən ʔlami-təwiye.

There are only two stresses in each of the words in (167) and (168). By considering longer words, however, we can see that main stress is only retracted as far as the penultimate stressed syllable, even when there are other stressed syllables to the left:

(169) a. téhsákw-apás-oltí-ne.  
 on.top-pl.walk-PL-11  
 'Let's (pl.) walk around on top.'

b. téhsákw-apás-oltí-ne    téməno.  
 on.top-pl.walk-PL-11    later  
 'Let's (pl.) walk around on top later.'

In an appropriate stress phrase, main stress may be retracted across a word boundary:

(170) a. ákənotə́má-kə́n-ə́l                      n-kísi' not-ə́m-ə́n-ə́l  
 tell.story-NOM-33IN 1-past hear-TI-3IN-33IN  
 'I heard stories.'

= b. n-kísi' not-ə́m-ə́n-ə́l ákənotə́má-kə́n-ə́l.

Stress retraction may be formalized in terms of grid alignments as follows:

(171) Stress Shift

$$\left[ \begin{array}{ccc} & & x \\ Y & & \\ & x & x \end{array} \right] Z \longrightarrow \left[ \begin{array}{ccc} & & x \\ Y & & \\ & x & x \end{array} \right] Z$$

where [...] is a stress phrase and  $Z \neq \emptyset$ .

This rule should be interpreted so that it applies in any non-final stress phrase in which there are two grid-adjacent beats, the first of which is one level lower than the second. The rule will then convert the metrical grid for cíhpə́lakə́n shown in (172a) to that shown in (172b).<sup>17</sup>

(172) a.                      x  
                                   x            x  
                                   x            x    x  
 c i h p ə l a k ə n

b.                      x  
                                   x            x  
                                   x            x    x  
 c i h p ə l a k ə n

If we allow Stress Shift to follow Clash Avoidance (14), then we will incorrectly permit retraction to the initial syllable in a word like téhsáhkwapásoltíne:

```

(173)
      x
      x
      x      x      x      x      x
      x      x      x      x      x      x
t e h s a h k w a p a s o l t i n e

      x
      x
      x      x      x      x
      x      x      x      x      x
* t e h s a h k w a p a s o l t i n e

```

I will therefore assume that Stress Shift precedes Clash Avoidance. Main Stress will then only be retracted to the penultimate stressed syllable in this word, as shown in (174).

(174) Main Stress Rule

```

                                     x
      x      x          x          x
      x      x      x  x  x      x
t e h s a h k w a p a s o l t i n e
```

Stress Shift:

```

                                     x
      x      x          x          x
      x      x      x  x  x      x
t e h s a h k w a p a s o l t i n e
```

Clash Avoidance:

```

                                     x
      x          x
      x      x          x          x
      x      x      x  x  x      x
t e h s a h k w a p a s o l t i n e
```

This appears to be a correct result.

-- Notes --

1. Apparently a nonce form, not an established word of the language.

2. This adjustment is probably not truly optional. I suspect, in fact, that it depends in some way on the phonetic length of the two stressed syllables in question and whether or not they are separated by a syllable containing an unstressable vowel. For this reason, a treatment of this process in terms of rhythmic intervals, rather than clashing stresses (cf. Hayes and Puppel (1985)) should probably not be excluded.

3. The final unstressed syllable of this word is also pronounced at a relatively high pitch in utterance-final

position. See 3.5 for some discussion of the general features of word-level intonation in Passamaquoddy.

4. This treatment is not always possible, however: sometimes a preverb or prenoun must be treated as a separate stress domain even when it is adjacent to the word it modifies. Sometimes either treatment is possible. The conditions which govern this choice remain undetermined.

5. For more on palatalization, see 6.6.2.

6. I know of one possible example of a morpheme which contains an irregular /ə/ of this kind. The AI and II final /-əpe-/ 'liquid' apparently begins with /ə/, since connective /i/ is never inserted before this morpheme: we have at-pe (change-liquid-(3)) 'the water level changes,' for example, not \*aci-pe. (We also find surface ə in the historically related morphemes like /-əpi/ 'liquid': kəmiwən-əpi-k (rain-liquid-LOC) 'rainwater (loc.).') This putative underlying /ə/ must be assumed to undergo syncope in all environments, however, since it never appears on the surface, even where it is otherwise obligatory to treat /ə/ as stressable. For example: while /ə/ would regularly undergo syncope in underlying /at-əpe-w/, we would expect /ə/ to surface after /sakh-/ 'into view,' where it would regularly be stressable. Indeed I have recorded Maliseet səkh-əpe 'water is showing through, coming through,' with -əpe- as expected. From Passamaquoddy speakers, however, I have recorded only -pe- after /sakh-/, with loss of /h/ between consonants: sək-pe 'water is coming into view; it projects into view out of water'; sək-pé-t-ol 'they (in.) project into view out of water.'

Forms containing /-əpe-/ are irregular in another way as well: a /ə/ in the syllable which precedes /-əpe-/ is always treated as stressable, whether or not it is in a position in which this treatment would otherwise be expected. Thus, for example, the second /ə/ of /cələk-/ 'squeeze' is treated as stressable in cələk-pe (squeeze-liquid-(3)) 'it is oozing, leaking,' although the second /ə/ in word-initial /((C)ə [+sonorant] ə/ is regularly treated as unstressable. (The second /ə/ of /cələk-/ must be underlyingly unstressable, since the /ə/ of /-ən/ 'by hand' is stressable by alternating stressability in h-cələk-ən-a-l (3-squeeze-by.hand-DIR-3.OBV) 'he squeezes the other (something soft).')

7. In Sherwood's analysis, there is no distinctive length in surface forms in Maliseet, since he writes ə and o for what I analyze as ɔ and ɔ• before w. (See 3.3 for discussion.) While ə is always phonetically short, Sherwood derives some occurrences of surface i from /ə/ and some occurrences of surface a from /ā/. These vowels, like i from /i/ and a from /a/, can be phonetically either long or short. (For discussion of these aspects Sherwood's analysis, see 5.2.13 and 6.5.)

8. Goddard, Hockett, and Teeter (1972) and Miner (1981) have analyzed vowel length alternations in Menomini which depend on a left-to-right syllable count -- and which may well be cognate with the strong/weak alternations of the Eastern Algonquian languages -- by means of a rule which assigns a diacritic feature [tonic].

9. Halle and Vergnaud use the term "feet" for metrical constituents of the lowest metrical level (my "subfeet") and call

the constituents of the second level "cola." I have chosen to reserve the term "foot" for constituents of the second level because these correspond to what we would presumably want to call "feet" in an analysis of Passamaquoddy stress which posited metrical constituent structure but did not treat the stressable/unstressable distinction metrically.

10. The initial /ə/ of /-əpən/ is in fact epenthetic rather than underlying, but nothing turns on this point here.

11. In a detailed proposal of this kind, we would probably want to assign different costs for underlying floating vowels in different contexts. This would give us a way to state, for example, that inherently stressable /ə/ is common before obstruents but uncommon before sonorants. We could also assign greater cost to underlyingly unstressable /i, a, o/ than to underlyingly unstressable /ə/. For discussion of a model of the lexicon in which it might be possible to state such generalizations, see Bochner (1988).

12. An additional rule of this type is motivated in 5.7.4.

13. It would probably be more accurate to say that the k of sokəlan becomes ambisyllabic after the application of Schwa Support. In sufficiently rapid speech for the ə of this word to be deleted altogether, this k presumably remains part of the syllable sok.

14. The symbol "#" is used in the statement of this rule simply as a convenient way to indicate the edge of a word domain. My use of the symbols "#" and "+" in various rules and representations in this work is not intended to imply any claims about the status of boundaries in phonological representations.

15. This rule should presumably be restricted to obstruents. With the exception of the hm of exceptional nehm 'turkey' there are no cases of word-final clusters in which the last segment is a sonorant.

16. The negative suffix /-w(i)-/ never triggers mutation: má te əpí-wi 'he does not sit.' The stem /wisi-/ 'be named' undergoes mutation both before the third person suffix /-w/ and before the nominalizer /-wən/: lí-wiso 'he is named thus,' k-wísə-w n 'your (sg.)name.' On the other hand, the stem /pikti-/ 'break wind' undergoes mutation before /-w/ but not before /-wən/: píkto 'he breaks wind,' píkti-wən 'anus.'

17. Note that Stress Shift, as I have formulated it here, is not a "rhythm rule" in the sense of Hayes and Puppel (1985), since it is applicable in any stress phrase which is not final in an utterance, regardless of metrical context. It is not in fact clear, however, that the rule is equally applicable in all non-final environments. It would not be surprising if there are further conditions which govern the applicability of this process.

## Chapter 5

### Syncope of /ə/

The role of the stressable/unstressable distinction in the phonology of Passamaquoddy is not limited to stress assignment. Vowel/zero alternations in a large number of morphemes are also governed by conditions which involve stressability. We will see, for example, that the medial -əcək- 'messy' appears with an initial ə in h-pásk-əcək-ən-a-l (3-break-messy-by.hand-DIR-3.OBV) 'he breaks the other (something squishy) with his hand' because this vowel is in a stressable position, following the cluster sk. In míl-cək-əcíhte (various-messy-color-(3)) 'it is multi-colored,' where the conditions which govern stressability would permit the initial ə of -əcək- to remain unstressable, we find -cək- instead.

Alternations like that seen in -əcək- are found in a diverse set of environments in Passamaquoddy and appear to reflect the application of five different rules. I will use the term "syncope" to refer to any of the rules of the language which produce vowel/zero alternations and are conditioned by stressability, with the exception of Vowel Elision, a rule deleting the second of two adjacent vowels if it is unstressable, which will receive separate treatment in Chapter 8.



Most of the vowels which alternate with zero in syncope either appear as ə when they surface or can straightforwardly be derived from underlying /ə/. The present chapter is primarily concerned with these. In Chapter 6 I will argue that certain occurrences of syncoating i, a, and o are not derived from /ə/, but instead reflect underlyingly unstressable /i/, /a/, and /o/.

Schwa/zero alternations for which stressability is a conditioning factor are found in the following environments:

- (1) a. before obstruents
- b. before /h/
- c. between /h/ and /m/
- d. between identical non-syllabics
- e. at the beginning of a word

The rules which produce these alternations are discussed below, as are several other phonological processes of Passamaquoddy which are reflected in the surface forms of words which have undergone syncope.

I argue in this chapter that the vowel/zero alternations found in the environments in (1) require us to postulate five distinct rules which delete unstressable /ə/. We will see in Chapter 6 that there is reason to believe that the rules for environments (a) and (b) should be generalized so that they are also applicable to unstressable vowels other than /ə/. In section 7 of this chapter I suggest that one of the rules which is involved in the derivation of geminate structures from sequences of identical non-syllabics can be generalized to account for syncope in environment (d).

Now without some way of representing stressability as a property of individual segments, the alternations of (1a-e) would be very puzzling indeed, since we would then be obliged to repeat the complex set of conditions under which underlyingly unstressable /ə/ comes to count for stress placement in each of five deletion rules. On the other hand, any theory which gives us a way to distinguish between stressable and unstressable vowels will allow us to formulate the rules of syncope without this undesirable repetition. Thus any of the accounts of stressability which we considered in the preceding chapter will permit us to give a reasonably straightforward analysis of syncope.

These alternative theories of syncope are not equivalent in explanatory force, however. First, it is easy to see that an analysis which is based on a diacritic theory of the stressable/unstressable distinction is unsatisfactory. Why should five deletion rules, as well as the process of stress assignment, be sensitive to the value of a diacritic feature like [strong]? Either a metrical or a CV theory of stressability is clearly preferable to such a diacritic approach. In a metrical theory, we can state the rules of syncope so that they delete unstressed vowels. Within the CV framework, we will instead make floating vowels the targets of deletion. In either case, potential targets of syncope can be identified on a structural basis.

I will argue in 5.2, however, that the CV theory of stressability is preferable to a metrical account for the analysis of syncope because it postulates an intimate connection between the conditions for stressability and the basic

syllabification rules of Passamaquoddy. The significance of this connection is revealed by the fact that syncope takes place only where the output of deletion is consistent with independent conditions on surface syllabification.

In 4.5 we saw that an unsyllabified C-slot is permitted at the beginning of a word in Passamaquoddy (and possibly also at the end), but that medial segments must be syllabified in surface forms. The syllabification rules, together with the rule which deletes /h/ before clusters, have the result that triconsonantal clusters are generally of the form CsC, while longer sequences of non-syllabics are regularly excluded. Correspondingly, there are forms like kpácale (hoarse-(3)) 'he is hoarse' in which syncope takes place after an initial consonant and leaves that consonant unsyllabifiable (cf. n-káp-acàl (1-hoarse) 'I am hoarse'), but syncope never results in an unsyllabifiable medial consonant. The longest clusters produced by syncope (after h-deletion and certain adjustments to geminates) are triconsonantal clusters of the permitted type CsC. We noted, for example, that the initial a of -acək- is not subject to syncope in h-pásk-acək-ən-a-l. Because this a is retained on the surface, the impermissible cluster skc does not arise in the derivation of this form.

It is not the case, however, that syncope is permitted wherever its output does conform to the requirements of surface syllabification. Syncope is blocked, for example, in a word like áps-əkíhkwan (small-size-(3)) 'it is small,' where the initial a of /-əkíhkwan-/ II 'be a size' is stressable because it follows the cluster in /aps-/ 'small.' (Compare kín-kíhkwan (large-size-(3)) 'it is big.'). But there is nothing wrong with the

sequence psk in itself. In fact words containing psk are common: apskapo 'he opens his eyes,' kínapskóso 'he is fat,' sákətiy-ápske 'it is a flat rock,' pskáhc 'have the other find him.' Nor would the cluster mk be in any way anomalous if the first /ə/ of /-əkihkwən-/ were deleted in nátəm-əkihkwən (fairly.big-size-(3)) 'it is fairly big.' In fact, syncope produces just this cluster in hsám-kíhkwən (too-size-(3)) 'it is too big,' where the presence of a full vowel instead of /ə/ in the syllable preceding /-əkihkwən-/ allows the underlying initial /ə/ of this final to remain unstressable. Thus the observed restrictions on syncope cannot be recast in terms of output conditions. To explain the fact that clusters in the output of syncope conform to the same restrictions as those in non-alternating forms, we need a theory of syncope which relates stressability to syllabification. The CV analysis of stressability provides the basis for such an account.

A problem for the CV approach arises in connection with the analysis of deletion in environment (1e). I argued in 4.5.7 that word-initial unsyllabified C's are extrametrical and thus invisible to word-level rules. But the rule which deletes unstressable /ə/ at the beginning of a word is blocked by an initial C. Thus on the CV account this rule must be permitted to analyze initial segments which should be unsyllabifiable and hence extrametrical. This problem can be resolved, however, by assigning the syncope rule in question to the phrase level, since initial C' is extrametrical only on the word domain. Two possible variants of this solution are considered in 5.9.

The chapter is organized as follows. Section 1 presents several arguments that syncope results from the application of deletion rules rather than a complementary process of epenthesis. Section 2 provides a detailed analysis of pre-obstruent syncope and compares the explanatory value of our three competing models of the stressable/unstressable distinction in this domain. Section 3 discusses Initial Devoicing and several other rules which account for the reduction of word-initial sonorants in clusters which result from the application of syncope or from the addition of one of the personal prefixes to C-initial stems. Section 4 sets out to determine the underlying forms of these prefixes and provides a critique of the idea that most or all surface sequences of non-syllabics in Passamaquoddy can be derived by syncope. Section 5 introduces the second syncope rule, which deletes unstressable /ə/ before /h/. Section 6 deals with syncope between /h/ and /m/. The phonology of geminate clusters is discussed in section 7, which argues that syncope between identical non-syllabics is the result of a more general process which is involved in geminate formation. Section 8 analyzes two rules which delete /h/, one which is applicable to the output of syncope and one which is applicable only in certain words which are exceptions to pre-obstruent syncope. The deletion of word-initial unstressable /ə/ is discussed in section 9.

### 5.1 Arguments for deletion

The first point that we need to consider in analyzing syncope in Passamaquoddy is whether the alternations in question

reflect epenthesis or deletion. I will sketch five arguments in this section which favor a deletion analysis of syncope. Ultimately, of course, we will see that syncope is not a unitary process. Not all of the arguments given here can in fact be made for each of the rules of syncope. The more detailed discussions of the various syncope rules which follow in later sections will make it clear, however, that one or more of these arguments can be made in each case.

In Chapter 7 we will see that some of the segments which undergo syncope are in fact derived by an earlier process of epenthesis. Thus vowel/zero alternations in certain forms actually reflect both epenthesis and deletion. Within the CV analysis of syncope for which I will be arguing, there is another sense as well in which epenthesis is involved in syncope, since in this analysis the role of the stressable/unstressable distinction in syncope is derived from the interaction of segmental deletion processes with the rules of V-slot epenthesis which were formulated in Chapter 4. Nonetheless, it remains the case that five deletion rules are required to account for the alternations that we find in the environments in (1).

The first argument for deletion that I will consider here is based on the fact that the quality of a vowel which alternates with zero in syncope cannot always be predicted from its phonological context. Consider, for example, the underlined i of (2a) and the underlined a of (3a). Both vowels are subject to syncope, as a comparison with the (b) forms indicates. Yet the two vowels occur in the same phonological environment, between g and hk.

- (2) a. ps-ihkə-k  
 wear(?)-by.body-3AN-(SUBJ)  
 'if he wears it'
- b. h-pas-kəm-ən  
 3-wear(?)-by.body-3IN  
 'he wears it'
- (3) a. psahk-éyo  
 sorry-AI-(3)  
 'he is sorry about something'
- b. mask-éyi-n  
 (3)-sorry-AI-PEG  
 'he is sorry about it'

Of course, the syncopating i of (2a) is morpheme-initial while the syncopating a of (3a) is morpheme-internal; but we will see in Chapter 6 that alternating vowels of both types can occur in either position. Since there does not appear to be any phonological basis for predicting whether i or a will show up in the alternating morphemes in (2) and (3), the vowel which actually occurs must be lexically specified in some way. One way to do this is to set up underlying forms which contain the unpredictable vowels: /pas-ihkəm-/ 'wear,' /masahk-eyi-/ 'be sorry.' We can then derive both the (a) and the (b) forms in (2) and (3) if we can write rules which will delete the appropriate vowels in each case. I will argue in Chapter 6 that this is in fact the right approach to the analysis of these forms. (The loss of /h/ between consonants in (2b) and (3b) and the alternation of m with p in (3) result from independent rules.)

Syncopating ə is never found on the surface before hC. On the other hand, both syncopating ə and syncopating a occur before sC. Here again, the quality of a vowel which is subject to syncope cannot be predicted from phonological context. For example, both the alternating ə of -məsk- 'find' and the alternating a of -askot- 'field' may occur between m and sk:

(4) a. məsk-ʒm-ən  
 (3)-find-TI-3IN

'he finds it'

b. psk-əm-ən  
 find-TI-1-(SUBJ)

'if I find it'

(5) a. nátəm-askót-e  
 fairly.big-field-II-(3)

'it is a fairly big field'

b. kín-skót-e

large-field-II-(3)

'it is a big field'

Setting up underlying /məsk-/ 'find' and /-askot-/ 'field' gives us a way to specify the unpredictable vowels of these morphemes. But of course this solution requires us to postulate a rule to delete /ə/ and /a/ in (4b) and (5b).

A second argument for deletion comes from the fact that the positions in which alternating vowels are found are not always predictable. In this connection, consider the examples in (6)



and (7). Here a ə appears at the beginning of the root in prefixed forms, but not in unprefixed forms.

(6) a. ht-əsakí-y-a-l  
3-look-TA-DIR-3.OBV  
'he looks at the other'

b. sakí-y-à-n  
look-TA-DIR-2  
'look (sg.) at him!'

(7) a. ht-əsi-h-m-ów-a-l  
3-give.drink-TI-TI-TA-DIR-3.OBV  
'he gives the other something to drink'

b. sí-h-m-ow-à-t  
give.drink-TI-TI-TA-DIR-3AN-(SUBJ)  
'if he gives the other something to drink'

Now there can be no general rule which inserts ə after a prefix and before /s/, since most roots that begin with s do not add ə in such cases. The roots sakəl- 'hard, firm' and sikte- 'to death, extremely' are typical in this respect. Neither adds ə after the third person prefix in (8) or (9). (Note also that the prefix appears in its pre-vocalic form with t in (6) and (7), but lacks this t in (8) and (9).)

- (8) a. sákəl-éyo  
 hard-AI-(3)  
 'it (an.) is hard'
- b. h-sákəl-ən-əm-ən  
 3-hard-by.hand-TI-3IN  
 'he holds it tight'
- (9) a. síkte-hpáyo  
 to.death-scared-(3)  
 'he is very scared'
- b. h-síkte-hpáwəl-a-l  
 3-to.death-scare-DIR-3.OBV  
 'he scares the other to death'

The ə which follows the prefix in (6a) and (7a) is an unpredictable property of the roots in these forms. Again it seems appropriate to attribute this ə to underlying forms: /əsaki-y-/ 'look at,' /əsi-h-əm-əw-/ 'give (someone) something to drink.' But such an analysis presupposes a rule of deletion which will remove word-initial /ə/ in (6b) and (7b). We will take another look at the question of predictable and unpredictable sites of alternation in 5.4 in connection with the question of the status of underlying consonant clusters.

The distribution of connective /i/ provides the basis for a third argument in favor of a deletion analysis of syncope. We noted in 4.2.2 that roots which end in a non-syllabic add /i/ before an element which begins with a non-syllabic. (A more detailed discussion will be found in 6.6.) But connective /i/ is not used before morphemes in which an initial vowel is subject to

syncope. If we suppose that syncope involves the deletion of an underlying vowel, we can account for this fact.

Consider, for example, the forms in (10).

- (10) a. pám-skót-e  
along-field-(3)  
'there is a field'
- b. wál-kil  
good-size-(3)  
'he is nice and big'

Since both pám- and wál- end in consonants, we would expect these roots to add /i/ before the apparently consonant-initial material which follows them in (10). The absence of connective /i/ in these forms is therefore surprising. But a comparison with (11) shows that the medial -skot- 'field' and the final -kil- 'be a size' have the vowel-initial alternants -askot- and -kil-. (For the former, compare also the examples in (5).)

- (11) a. áps-askót-e  
small-field-II-(3)  
'it is a small field'
- b. áps-ákil  
small-size-(3)  
'he is small'

If we assume that -skot- and -kil- are underlyingly vowel-initial in (10) as well, and that the distribution of connective /i/ is determined by these underlying representations, then the absence of connective /i/ in (10) is explained. But this explanation

requires us to suppose that a rule of deletion applies in the derivations of the forms in (10).

We reach the same conclusion if we consider the use of connective /i/ in derivatives of /ʔsaki-y-/ and /ʔsi-h-əm-əw-/ in which these stems are used as complex finals, as shown in (12).

(12) a. ná-t-sakí-y-a-l

(3)-go-look-TA-DIR-3.OBV

'he goes somewhere and sees the other'

b. h-kís-si-h-m-ów-a-l

3-past-give.drink-TI-TI-TA-DIR-3.OBV

'he gave the other something to drink'

Postulating underlying /ʔ/ in /ʔsaki-/ 'look at' and /ʔsi-/ 'give drink' accounts for the fact that connective /i/ is not used before these elements after /nat-/ 'come, go' or /kis-/ 'past,' so that we find nat- and kis- in (12) rather than naci- and kisi-, the usual preconsonantal forms of these roots. It is an important point as well that this argument from the distribution of connective /i/ points to underlying vowels in the same locations as the argument from unpredictable surface ʔ which was given above. The convergence of distinct criteria for underlying forms in cases like these gives us reason to believe that the alternations which we have grouped together as syncope are still integrated into a coherent system in the grammar of Passamaquoddy and have not been reduced to a set of independent allomorphic relationships. (See the introduction to 6.4 for discussion of the kinds of alternations that we find where speakers have

apparently abandoned phonological analyses of syncope for particular morphemes.)

A fourth argument for the deletion analysis comes from Initial Change, the system of vowel mutations which characterizes certain Conjunct verb paradigms. The most frequent expression of Change is the shift of /ə/ to /e/ in the first syllable of a verb or preverb, as shown in (13). (For further discussion, see Chapter 9, especially 9.1.)

- (13) a. h-pá1-tá-h-a-l  
3-miss-strike-TA-DIR-3.OBV  
'he misses the other (with a blow)'
- b. pé1-ta-h-a-t  
miss-strike-TA-DIR-3AN-(PERF)  
'when he missed the other'

It is not always possible to predict the Changed form of a root by inspecting the Unchanged surface form. For example, the verb in (14a) is formed on the root tə1- 'ongoing.' By analogy with the root pə1- 'miss' of (13a), we might expect to find Changed forms with \*te1-, corresponding to pe1- in (13b). The form which actually occurs, however, is etə1-:

- (14) a. tǎlí-ne  
ongoing-die-(3)  
'he is dying'
- b. étǎlí-ne-t  
ongoing-die-3AN  
'where he is dying'

But notice that etəl- is what we would expect as the Changed form of a root ətəl-. Or, to put the matter differently, we can predict the Changed form of təl- if we assume that the underlying form of this root is /ətəl-/ and the the surface form təl- results from the deletion of underlying /ə/ in word-initial position.

We saw above that /ə/ is dropped at the beginning of a word but retained after the third person prefix in /əsaki-y-/ 'look at' and /əsi-h-əm-əw-/ 'give (someone) something to drink.' If we set up underlying /ətəl-/ 'ongoing' to account for the Changed form etəl-, we will therefore expect to find -ətəl- in prefixed forms. This prediction is correct:

- (15) nít    te    wt-ətəlí-na-n.  
           there EMPH 3-ongoing-die-SUBORD  
           'He is dying right there.'

Here again we see that different criteria for the choice of an underlying form lead to the same conclusion: evidence from Initial Change and from vowel alternations under prefixation generally converges on an underlying representation from which all of the inflected forms of a verb may be derived. There are a few roots whose prefixed, unprefixed, and Changed forms require partially distinct underlying representations, but the vast majority are regular. Thus the schwas of the roots /pəs-/ 'wear(?)' and /məsahk-/ 'sorry,' which we set up in underlying representations on the strength of the fact that they occur in surface forms like h-pəs-kəm-n 'he wears it' and məsk-éyi-n 'he

is sorry about it,' are confirmed by Changed forms like those in (16) in which e occurs in their place.

- (16) a. pés-kə̀-k  
wear(?)-by.body-3AN-(PERF)  
'when he wore it'
- b. mésk-eyì-t  
sorry-AI-3AN-(PERF)  
'when he was sorry about it'

In (17), Initial Change gives e for the initial schwas of /ə saki-y-/ and /ə si-h-əm-əw-/, which we attributed to the underlying forms of these stems to account for their shape after prefixes and for the fact that roots ending in non-syllabics do not add connective /i/ before them.

- (17) a. ésaki-y-à-t  
look-TA-DIR-3AN-(PERF)  
'when he looked at the other'
- b. ési-h-m-ów-a-t  
give.drink-TI-TI-TA-DIR-3AN  
'when he gives the other a drink'

This convergence of criteria for the choice of underlying forms generally holds even where some of the forms of a paradigm show variation. So, for example, the root kwakw- 'dirty,' shown in its word-initial form in (18a), appears in prefixed forms both as kwakw- and as əkwakw-, as shown in (18b). The first of these prefixed alternants suggests underlying /kwakw-/, while the second instead suggests /əkwakw-/. Now if both underlying forms

are possible, then we should find both kwakw- and ekwakw- in Changed forms. And indeed we do, as illustrated in (18c):

- (18) a. kwákwi-ptín-e  
 dirty-hand-AI-(3)  
 'he has dirty hands'
- b. n-kwákwi-ptin-à-pən  
 ~ nt-əkwakwí-ptin-à-pən  
 1-dirty-hand-AI-11  
 'we (du. exc.) have dirty hands'
- c. kwákwi-ptin-à-t  
 ~ əkwakwí-ptin-à-t  
 dirty-hand-AI-3AN-(PERF)  
 'when he had dirty hands'

The form of the three surface shapes of the root 'dirty,' the distribution of these surface alternants, and the fact that variation is found only at certain points in paradigms can all be explained by postulating two alternative underlying forms for this morpheme, provided that we adopt a deletion analysis of syncope.

The last argument for deletion that I will offer here is based on syncoating vowels with idiosyncratic properties. In 5.2.7 we will see that a number of morphemes contain schwas which must be marked as exceptions to case (1a) of syncope, syncope before obstruents. Some of the same vowels must be marked as exceptions to case (1e), syncope in word-initial position, as we will see in 5.9. The /ə/ of /əpi-/ 'sit' is an exception of both types: this vowel is retained on the surface, contrary to the



usual patterns of syncope, in əpó (sit-(3)) 'he sits' and in sáŋkew-əp (calm-sit-(3)) 'he sits still.' (Compare sáŋkew-əp (calm-sit) 'sit (sg.) still!', with irregular retention of the /ə/ of /pi-/ 'sit,' and ímiyə-w-p (pray-DA-liquid) 'holy water,' with regular pre-obstruent syncope in /-əpi/ 'liquid.'). Case (1d) of syncope, on the other hand, is exceptionless: unstressable /ə/ is consistently deleted between identical non-syllabics. Thus /əpi-/ 'sit' surfaces without its initial /ə/ in éwép-po (up-sit-(3)) 'he sits up.' Now in 5.2.7 we will see that particular vowels must be marked as exceptions to syncope rules: exceptionality cannot be a property of morphemes as a whole, since a single morpheme may contain one /ə/ which participates regularly in vowel/zero alternations and another which is exceptional. But at least syncope between identical non-syllabics must therefore involve a process of deletion. Since /ə/ must be present in the underlying form of a morpheme like /əpi-/ 'sit' to be marked as exceptional, the geminate consonant that we find in a form like éwép-po must be derived from an underlying sequence in which identical non-syllabics are separated by an intervening /ə/.

## 5.2 Deletion of /ə/ before obstruents

The most frequently encountered schwa/zero alternations in Passamaquoddy are those produced by the deletion of unstressable /ə/ before obstruents. I will examine these alternations in some detail in this section with an eye to bringing out the issues which bear on the choice of a theory of stressability. A simple statement of the deletion rule in question can in fact be

given under any of the accounts of stressability which were developed in Chapter 4. I will argue, however, that the CV analysis provides a better basis for an explanation of the nature of pre-obstruent syncope than either of that alternatives that we have considered.

Of course, our theory of stressability must also accommodate several other types of syncope. For the most part, though, the other syncope rules of the language present the same analytical problems as the rule of pre-obstruent syncope. In presenting formal analyses of these processes in the sections which follow, I will generally assume that the CV model of stressability is right, rather than trying to develop parallel accounts in each case. Possible alternatives will be discussed only where the choice of an analytical framework appears to make a difference for the empirical import or the explanatory force of the resulting analysis.

Schwa/zero alternations before obstruents are particularly common in initial syllables. Several typical examples follow.

- (19) a. n-p<sup>á</sup>t-hí-k  
           1-hook-TA-AI  
           'I hook fish'
- b. p<sup>t</sup>-íhí-ke  
           hook-TA-AI-(3)  
           'he hooks fish'

- (20) a. h-tápi-tahá-t-əm- n  
 3-heed(?)-think-TI-TI-3IN  
 'he thinks about it'
- b. tpi-tahá-t-əm  
 heed(?)-think-TI-TI-(3)  
 'he thinks'
- (21) a. n-kápacàl  
 1-hoarse  
 'I am hoarse'
- b. kpácále  
 hoarse-(3)  
 'he is hoarse'
- (22) a. n-kás-éhl-əkw  
 1-intense-TA-INV  
 'he hurts me'
- b. ks-éhl-a-t  
 intense-TA-DIR-3AN-(SUBJ)  
 'if he hurts the other'
- (23) a. n-káskəmihík  
 1-take.shortcut  
 'I take a shortcut'
- b. kskəmihíke  
 take.shortcut-(3)  
 'he takes a shortcut'

- (24) a. h-pəkkika-1-a-1  
 3-grab-TA-DIT-3.OBV  
 'he grabs the other'
- b. pkika-1-a-t  
 grab-TA-DIR-3AN-(SUBJ)  
 'if he grabs the other'

There are also a number of morphemes in which /ə/ is deleted before an obstruent in a medial syllable. Examples of the resulting alternations are given in (25)-(27). The alternating schwas are underlined.

- (25) a. áps-əkíhkw n  
 small-size-(3)  
 'it is small'
- b. kíñ-kíhkwən  
 large-size-(3)  
 'it is big'
- (26) a. másk-əsít-e  
 smelly-foot-AI-(3)  
 'his feet stink'
- b. kwákw-sít-e  
 dirty-foot-AI-(3)  
 'he has dirty feet'

(27) a. h-kwətákən

3-throat

'his throat'

b. píəwi-kwtákən-e

different-throat-AI-(3)

'his voice is changing (said of teenagers)'

For the most part, ə does not alternate with zero before sonorants in environments otherwise comparable to those in which pre-obstruent syncope takes place. In (28) and (29), for example, ə is retained before l and m in initial syllables in both prefixed and unprefixed forms. (Compare (19) and (20) above for deletion after a single consonant before t and p.) The examples in (30) and (31) show the loss of /ə/ before obstruents after /kis-/ 'past' and /pet-/ 'arrive,' then the retention of /ə/ before sonorants after these initials.

(28) a. h-kəlól-tí-ni-ya-l

3-argue-RECIP-PEG-33PROX-3.OBV

'he argues with the other'

b. kəlól-tó-w-ək

argue-RECIP-3-33PROX

'they (du.) argue with each other'

- (29) a. h-pámí-ph-a-l  
 3-along-carry-DIR-3.OBV  
 'he carries the other along'
- b. pámí-ph-â  
 along-carry-3PASS  
 'he is carried along'
- (30) a. h-kís-si-h-m-ów-a-l (/w-kis-asi-h-am-aw-a-al/)  
 3-past-give.drink-TI-TI-TA-IDR-3.OBV  
 'he gave the other something to drink'
- b. h-kís-anoh-m-an  
 3-past-buy-TI-3IN  
 'he bought it'
- c. n-kís-awéhka-n  
 1-past-use-3IN  
 'I used it'
- (31) a. pét-kil (/pet-akil-w/)  
 arrive-size-(3)  
 'he reaches a size (in growth)'
- b. pét-an-am  
 arrive-by.hand(?)-TI-(3)  
 'he gets there'

In 5.7 we will see that /ə/ is subject to syncope between identical sonorants as well as between like obstruents. We will also see in 5.9 that word-initial /ə/ may undergo syncope before either a sonorant or an obstruent. I will argue, however, that the rules which account for these cases of syncope are distinct

from the process which produces the alternations that we find in examples like (19)-(27). The latter rule deletes /ə/ only before an obstruent consonant.

Now what is most striking about pre-obstruent syncope is that it is subject to conditions which parallel those under which schwa may be skipped over by the stress rules. Six environments in which schwa is always counted as stressable were identified in 4.2. These are repeated here in (32).

(32) Schwa is always stressable if

- a. it is the last vowel of a word
- b. it follows a cluster of non-syllabics  
other than /hC/
- c. it follows /hl/
- d. it stands between /s/ and /hs/
- e. it is the first /ə/ in a word-initial sequence  
of the form / (C) ə [+sonorant] ə / in which the  
second /ə/ is unstressable
- f. it is in an even-numbered position, counting from  
left to right, in a maximal series of / C ə /  
sequences in which no /ə/ falls under (a)-(e)  
or is inherently stressable

As we will see below, pre-obstruent syncope is applicable only to schwas which are not inherently stressable and which are not in one of the environments in (32). In other words, /ə/ is deleted before obstruents only if it would not be counted in figuring stress placement if it were retained on the surface.

This tight relationship between syncope and the conditions for stressability is demonstrated in detail in subsections 1-6. Subsection 7 introduces a class of exceptions to pre-obstruent syncope which will figure prominently in several later discussions. Subsections 8-11 set out an analysis of pre-obstruent syncope within the framework of the CV theory of the stressable/unstressable distinction. Apparent cases of syncope after geminate clusters which present a potential problem for this analysis are discussed in subsection 12. The CV analysis of pre-obstruent syncope is compared with alternative accounts within the diacritic and metrical frameworks in subsections 13 and 14.

### 5.2.1 Schwa in final syllables

In 4.2.1 we saw that a ə which is not counted by the stress rules when it occurs in a medial syllable is always treated as stressable when it occurs in a word-final syllable. Thus we have penultimate stress in tá'lí-kən (ongoing-grow-(3)) 'it is growing,' showing that the /ə/ of /-kən-/ has been taken into account in assigning stress to this form, even though the corresponding vowel is skipped over by the Alternating Stress Rule when stress is assigned in the derivation of tá'lí-kən-ol (ongoing-grow-(3)-33IN) 'they (in.) are growing.'

The same pattern of weak and strong positions shows up in syncope: a /ə/ which may be deleted in medial position is always retained on the surface when it is the last vowel in the



underlying form of a word. This special treatment of final syllables results in alternations like those shown in (33)-(36). In (33)-(35) the last vowel of a stem is retained where no suffix follows but is subject to syncope when a suffix containing a vowel is added. A similar alternation in a suffix is shown in (36).

- (33) a. atóhk-átap  
 deer-head  
 'deer's head'
- b. atóhk-átp-əl  
 deer-head-33IN  
 'deer's heads'
- (34) a. nícalakw  
 (1)-father's.brother  
 'my father's brother'
- b. nícalk-ol  
 (3)-father's.brother-3.OBV  
 'his father's brother'
- (35) a. sísakw  
 'face, eye'
- b. sísk-ol  
 eye-33IN  
 'faces, eyes'

- (36) a. k<sup>́</sup>eti nípw-oltí-mək  
 future marry-PL-UNSPEC  
 'where there is going to be a marriage'
- b. k<sup>́</sup>eti nípw-ólti-mk-əpən  
 future marry-PL-UNSPEC-PRET  
 'where there was going to be a marriage'

In (33)-(36), /ə/ is obligatorily retained before a word-final consonant. It is not the case, however, that syncope is always blocked before a surface word-final consonant. In (37a), for example, /ə/ is deleted in the noun final /-əpi/ 'liquid' even though the following consonant surfaces in word-final position. The /ə/ of the reflexive suffix /-əsi-/ is deleted in (38a), where the following /s/ is word-final in the surface form. The full forms of these morphemes are shown in the (b) examples. (The /ə/ of /-əsi-/ is probably epenthetic. See 7.2 for discussion.)

- (37) a. ímiye<sup>̀</sup>-w-p  
 pray-DA-liquid  
 'holy water'
- b. kəmiwən-əpi-k  
 rain-liquid-LOC  
 'rain water (loc.)'

(38) a. kəlól-s

argue-REFLEX

'argue (sg.) with yourself!'

b. náci kəs-pa-hl-əsi-n

(1)-go wash-liquid(?)-TA-REFLEX-SUBORD

'I will go somewhere and wash myself (Subord.)'

The (a) examples in (37) and (38) are distinguished from those in (33)-(36) by the underlying presence of a word-final vowel: ímiyə-w-p is derived from /imiya-w-əpi/, kəlól-s from /kəlól-əsi/. In both cases, this underlying vowel is subject to Final Vowel Deletion. I will return to the question of the interaction of syncope and Final Vowel Deletion in Chapter 10. For present purposes, however, it is enough to note that the constraint which blocks schwa-deletion in word-final syllables in examples like ətóhk-átəp and nícáləkw will not be violated by syncope in forms like ímiyə-w-p and kəlól-s if it is stated in terms of a stage in derivations prior to the application of Final Vowel Deletion.

### 5.2.2 Cluster effects

After most types of consonant clusters, pre-obstruent syncope is blocked. We can see this effect in the examples in (39)-(42), which illustrate schwa/zero alternations in the finals /-əkil-/ AI 'be a size' and /-ətənim-/ TA 'hire' and the medials /-acək-/ 'messy' and /-əton(e)-/ 'mouth.' Each of these morphemes retains its initial /ə/ in case (a), where it follows a

sequence of non-syllabics, but loses this vowel in the other examples, where the preceding morpheme ends in a single non-syllabic. The roots /aps-/ 'small,' /sakh-/ 'into view,' and /pask-/ 'break' all contain non-alternating clusters which are presumably present as such in underlying representations. (See 5.4 for arguments against an alternative analysis which would derive such clusters through syncope.)

(39) a. áps-ǎkil

small-size-(3)

'he is small'

b. kín-kil

large-size-(3)

'he is big'

c. él-kil-ǎk

thus-size-3AN

'how big he is'

(40) a. h-sákh-ǎtamím-a-l

3-into.view-hire-DIR-3.OBV

'he appears, calls on the phone, etc. and hires  
the other'

b. ht-áp-támím-a-l

3-go-hire-DIR-3.OBV

'he goes somewhere and hires the other  
(and returns)'

c. nát-támím-a-l

(3)-go-hire-DIR-3.OBV

'he goes (or comes) and hires the other'

- (41) a. h-pásk-əcək-ə́n-a-l  
 ʒ-break-messy-by.hand-DIR-ʒ.OBV  
 'he breaks the other (something squishy)  
 with his hand'
- b. míl-cək-ə́cíhte  
 various-messy-color-(3)  
 'it is multi-colored'
- c. məc-cəkí-ptiné-hl-a-l  
 (3)-messy-hand-TA-DIR-ʒ.OBV  
 'he gets the other's hand(s) dirty'
- (42) a. h-pásk-ətóne-htá-h-a-l  
 ʒ-break-mouth-strike-TA-DIR-ʒ.OBV  
 'he hits the other, cutting the other's lip'
- b. kín-tón-e  
 large-mouth-AI-(3)  
 'he has a big mouth'

After clusters of /h/ and an obstruent, pre-obstruent syncope is permitted, just as it is after a single non-syllabic. The /hCC/ clusters which result from syncope do not surface, however, since /h/ is deleted before a sequence of non-syllabics. (The rule which deletes /h/ in this environment will be formalized in 5.8.1.)

In (43a) and (44a), /ə/ surfaces in final /hCəC/ because it is the last vowel of a word. With the addition of suffixes in (43b) and (44b), this constraint on syncope no longer comes into play, and /ə/ is deleted after /hC/. The resulting /hCC/ clusters are then reduced to surface CC.

- (43) a. p<sup>á</sup>ssiya<sup>é</sup>ntéhs<sup>ə</sup>tk  
           'window'  
       b. h-p<sup>á</sup>ssiya<sup>é</sup>ntésk-om  
           3-window-POSS  
           'his window'

- (44) a. cípiya<sup>á</sup>ht<sup>ə</sup>kw  
           cross  
       b. cípiya<sup>á</sup>tkw-is  
           cross-DIM  
           'cross (dim.)'

The examples in (45) show first the root /meht-/ 'finish' and the final /-əka/ 'dance,' then their combination, in which underlying /ht k/ is reduced to tk by syncope and h-deletion. Those in (46) provide similar evidence for syncope and h-deletion where /epahs-/ 'half' is combined with /-əs-/ 'by cutting edge.' The medial /-ahkw-/ 'wood,' the abstract AI final /-əsi-/, and their combination, with kws for underlying /hkw s/, are shown in (47).

- (45) a. méht-ewésto  
 finish-speak-(3)  
 'he finishes speaking'
- b. skícina<sup>á</sup>w-áka  
 Indian-dance-(3)  
 'he does an Indian dance'
- c. mé<sup>á</sup>t-ka  
 finish-dance-(3)  
 'he finishes dancing'
- (46) a. ht-é<sup>á</sup>phsi-ks<sup>á</sup>m-án  
 3-half-saw-3IN  
 'he saws it in half'
- b. pt-ás-óso  
 accidentally-cut-REFLEX-(3)  
 'he cuts himself accidentally'
- c. ht-é<sup>á</sup>pás-s-a-l  
 3-half-cut-DIR-3.OBV  
 'he cuts the other in half'
- (47) a. píht-ákw-át  
 long-wood-II-(3)  
 'it (stick-like) is long'
- b. píht-ensk-áso  
 long-body-AI-(3)  
 'he is tall'
- c. píht-ákw-so  
 long-wood-AI-(3)  
 'it (an., stick-like) is long'

Once again we see that the restrictions on syncope parallel the conditions under which /ə/ must be counted in stress placement: /ə/ following h-obstruent clusters is distinguished from /ə/ following other clusters in both cases. This parallelism is continued by the fact that /ə/ does not undergo syncope after /hl/, just as /ə/ after /hl/ is always "visible" to the stress rules. Compare (48a), with syncope in the inverse theme sign /-əko-/ after plain /l/, and (48b), where the /ə/ of /-əko-/ is retained after /hl/. (Here again the /ə/ which undergoes syncope has its source in epenthesis; see 7.2 for details.)

- (48) a. k-míl-ko-né-nno-l  
 2-give-INV-PEG-11-3.OBV  
 'he gives the other to us (inc.)'
- b. məskw... kt-əkwéci l-éhl-əkó-w- n  
 not.yet 2-try thus-TA-INV-NEG-SUBORD  
 'he has not yet tried to treat you (sg.) thus'

Similar treatment of the /ə/ of the reflexive final /-əsi-/ after /l/ and /hl/ is shown in (38) above.

### 5.2.3 Alternating stressability

If it is only unstressable /ə/ which is subject to syncope, then we should find alternating patterns of deletion which are complementary to the alternating patterns of stressability which were described in 4.2.4. That is, if even-numbered schwas in a



series are stressable, then the odd-numbered schwas in the series should be deletable (provided that the other conditions for syncope are met). Such alternating patterns of syncope are in fact well attested.

Consider, for example, the following forms of the stem /kətəkʷ-əni-/ 'stay over, spend the night (as at someone's house),' in which the root /kətəkʷ-/ 'over' is combined with an AI final otherwise unknown to me.<sup>1</sup> (The example is due originally to Teeter (1971:195).)

- (49) a. n-kətəkʷ-ən  
 1-over-AI  
 'I stay over'
- b. n-kisi' ktəkʷ-ən  
 1-past over-AI  
 'I stayed over'
- c. ktəkʷ-əno  
 over-AI-(3)  
 'he stays over'
- d. kətəkʷ-əni-t  
 over-AI-3AN  
 'he who stays over'

In (49a), the first /ə/ of underlying /kətəkʷ-əni/ is stressable because it follows the cluster /nk/ which is created by the addition of the first person prefix. Both the second and the third schwas of the stem follow a single consonant, and neither is inherently stressable, so both are included in a span within which alternating stressability holds. Thus the first of these

schwas is unstressable and the second is stressable. As expected, the stressable first /ə/ of /kətəkʷ-/ is retained on the surface, while the unstressable second /ə/ of this root is subject to pre-obstruent syncope.

In (49b) and (49c), all three schwas in /kətəkʷ-əni-/ are included in a single span for alternating stressability, since none of them follows a cluster. The first and third schwas therefore remain unstressable here, while the second becomes stressable. (The /ə/ of /-əni-/ surfaces as a stressed vowel in (49b) as a result of accentual adjustments triggered by the application of Final Vowel Deletion. More on this in Chapter 10.) Since the status of the two schwas of /kətəkʷ-/ is reversed in these examples with respect to the pattern in (49a), the first vowel of the root is deleted here rather than the second.

The first /ə/ of /kətəkʷ-/ has been replaced by the stressable vowel /e/ in (49d) as a result of Initial Change. Since the second vowel of the root is unstressable in the Changed stem /kətəkʷ-əni-/, this vowel is subject to syncope here just as it is in (49a).

The forms in (50) show a comparable pattern of alternations under prefixation in the root /pətəkʷ-/ 'round.' The combination of /ətəl-/ 'ongoing action' with the final /-əsəkwe-/ 'check traps' produces a series of four underlying schwas within which the patterns of alternating stressability work themselves out, with results for syncope as shown in (51). The underlying form of the stem is given first in each set of examples.

(50) a. /pətəkwi-lce-/

b. ptəkwi-lc

round-hand

'fist'

c. h-pətəkwi-lc

3-round-hand

'his fist'

(51) a. /ətəl-əsəkwe-/

b. təl-səkwe

ongoing-check.traps-(3)

'he is checking traps'

c. nt-ətəl-əskwè-pən

1-ongoing-check.traps-11

'we (du. exc.) are checking traps'

d. étəl-əskwe-t

ongoing-check.traps-3AN

'he is checking traps (Conjunct)'

Examples (49)-(51) illustrate the role of alternating stressability in schwa/zero alternations within paradigms. Comparable effects can be traced in derivationally related forms. In (52)-(54) the final /-əkikhwən-/ II 'be a size' and the medials /-əsit(e)-/ 'foot' and /-əton(e)-/ 'mouth' drop their initial schwas after a syllable containing a full vowel but retain them where the vowel of the preceding syllable is an unstressable /ə/, as we expect on the basis of alternating stressability.

- (52) a. tót-kíhkwan  
 extreme-size-(3)  
 'it is big to such an extent'<sup>2</sup>
- b. nátm-əkíhkwan  
 fairly.big-size-(3)  
 'it is fairly big'
- (53) a. lám-sit-á-wan  
 inside-foot-AI-NOM  
 'sole of the foot'
- b. panaw-əsít-e  
 open(?)-foot-AI-(3)  
 'his feet point out when he walks'
- (54) a. kéc-tón-a-t  
 edge-mouth-AI-3AN  
 'the edge of his mouth'
- b. məc-álək-ətón-e  
 bad-hole-mouth-AI-(3)  
 'he has a dirty mouth (uses bad language)'

(In the last of these examples, we might expect the /ə/ of /-alək-/ 'hole' to undergo syncope, since it is unstressable and precedes an obstruent. This morpheme is one of several exceptions to pre-obstruent syncope which will be discussed in 5.2.7.)

#### 5.2.4 Word-initial /((C)ə [+sonorant])ə/

We saw in 4.2.3 that the first /ə/ in word-initial /((C)ə [+sonorant])ə/ is ordinarily treated as stressable. Alternating stressability then begins with the second /ə/ in this configuration, which is therefore typically unstressable. Given our hypothesis that it is unstressable /ə/ which is subject to syncope, we expect to find that the second /ə/ in initial /((C)ə [+sonorant])ə/ is regularly deleted before an obstruent. This prediction is correct.

The pattern of syncope in question is illustrated in (55b,c) and in (56b), where the initial schwas of /-əkil-/ AI and /-əkikhwən-/ II 'be a size' are underlyingly the second vowels in appropriate word-initial sequences. The (a) forms are given for comparison.

- (55) a. áps-ə́kil  
 small-size-(3)  
 'he is small'
- b. wá1-kil (/wá1-ə́kil-w/)  
 good-size-(3)  
 'he is nice and big'
- c. ə́l-kil (/ə́l-ə́kil-w/)  
 thus-size-(3)  
 'he is big by so much'

- (56) a.  $\acute{a}ps-\mathfrak{a}k\acute{i}hk\mathfrak{w}\mathfrak{a}n$   
 small-size-(3)  
 'it is small'
- b.  $\mathfrak{a}l-k\acute{i}hk\mathfrak{w}\mathfrak{a}n$  ( $/\mathfrak{a}l-\mathfrak{a}k\acute{i}hk\mathfrak{w}\mathfrak{a}n-w/$ )  
 thus-size-(3)  
 'it is big by so much'

Pre-obstruent syncope is permitted under comparable conditions when the final  $/-\mathfrak{a}ka-/$  'dance' follows the root  $/p\mathfrak{a}m-/$ , 'along,' but in this case syncope is optional, an idiosyncratic property of this combination of morphemes:  $p\mathfrak{a}m-\mathfrak{a}ka \sim p\mathfrak{a}m-ka$  (along-dance-(3)) 'he dances.'

#### 5.2.5 Schwa between /s/ and /hs/

Since /hs/ surfaces as ss after  $/\mathfrak{a}/$ , we might expect some occurrences of  $/\mathfrak{a}/$  between underlying /s/ and /hs/ to be subject to pre-obstruent syncope. Alternatively, some occurrences of  $/\mathfrak{a}/$  in this environment might be expected to undergo the rule of syncope before /h/ which will be discussed in 5.5. In fact, however,  $/\mathfrak{a}/$  never undergoes syncope between /s/ and /hs/, just as  $/\mathfrak{a}/$  is always accessible to the stress rules in this context. Alternations to which this generalization is relevant are found only in diminutive and pejorative formations, however, where epenthetic  $/\mathfrak{a}/$  is inserted before suffixes of the form  $/-hs-/$ .

This epenthetic  $/\mathfrak{a}/$  is deleted in forms like (57b), where it follows a single non-syllabic other than /s/. In (58b) and (59b), on the other hand,  $/\mathfrak{a}/$  is maintained before the diminutive

suffix /-hs-/ because the stem ends in /s/. Similarly, epenthetic /ə/ is always maintained between occurrences of /-hs-/, as in the second diminutive shown in (60b).

(57) a. kát

'leg (including the foot)'

b. kát-s-is

leg-DIM-DIM

'leg (dim.)'

(58) a. káwis

'burdock (plant or seedpod)'

b. káwis-əss-is

burdock-DIM-DIM

'burdock (dim.)'

(59) a. wás-is

child-DIM

'child'

b. wás-əss-is

child-DIM-DIM

'child (dim.)'

(60) a. píł-eyá-hs-is

new-NF-DIM-DIM

'new baby'

b. píł-éya-hs-əss-is

new-NF-DIM-DIM-DIM

'new baby (dim.)'

See also examples (27)-(31) of 4.2.1 and the accompanying discussion.

### 5.2.6 Inherently stressable /ə/

Section 4.2.5 introduced a number of forms which contain inherently stressable schwas. These vowels are available to the stress rules even though schwas in comparable environments in other words are invisible to the rules of stress assignment. Inherently stressable schwas also fail to undergo deletion where other schwas are subject to pre-obstruent syncope.

Consider, for example, the items in (61), repeated from (61) of Chapter 4. The underlined schwas are inherently stressable. In each case, the underlined vowel meets all of the segmental conditions for deletion: it follows a single non-syllabic, precedes an obstruent, etc. Yet none of these vowels undergoes syncope. Compare the forms marked (a) in (62)-(64), where the underlined clusters are derived by syncope of /ə/ in environments which parallel those in (61a-e). (The forms marked (b) in (62)-(64) show that /ə/ surfaces in the roots of the corresponding (a) examples when the conditions for syncope are not met.)



- (51) a. kwácam-ək  
 outdoors-LOC  
 'outdoors'
- b. kətáwi-táwiye  
 want-fly-(3)  
 'he wants to fly'
- c. məté-hté-hsin  
 be.heard-strike-lie-(3)  
 'he is heard to fall with a crash'
- d. mətapé-hte  
 downhill-located-(3)  
 'it is situated facing downhill'
- e. məkásew-álohkí-ye  
 black-cloud-go-(3)  
 'there are black clouds'

- (62) a. kwáka-hsin (/kwəsaka-hsin-w/)  
 across-lie-(3)  
 'he lies across something'
- b. h-kwásaka-hsín-ən  
 3-across-lie-PEG  
 'he lies across it'

- (63) a. ktámak-éyo (/katamak-eyi-w/)  
 poor-AI-(3)  
 'he is poor'
- b. n-kátamak-èy  
 1-poor-AI  
 'I am poor'

- (64) a. pk-ə́n-à-t (/mək-ə́n-a-t-V/)  
 choose-by.hand-DIR-3AN-(SUBJ)  
 'if he picks out the other'
- b. mək-ə́n-a-l  
 (3)-choose-by.hand-DIR-3.OBV  
 'he picks out the other'

Of course, given our characterization of syncope as a process which deletes unstressable /ə/, these facts are hardly surprising. The underlined schwas in (61) are stressable, so they are not potential targets of deletion regardless of their segmental environments.

### 5.2.7 Exceptions to pre-obstruent syncope

Inherently stressable schwas like those in (61) are not exceptions to pre-obstruent syncope, since syncope affects only unstressable vowels. True exceptions to this rule do exist, however. In fact, they are fairly common.

Consider, for example, the medial /-alək-/ 'hole.' The /ə/ of this morpheme is clearly ignored in assigning stress to the forms in (65), since two syllables separate the last two stresses in both of these examples. Moreover, the /ə/ of /-ə́ton-/ 'mouth' is not subject to syncope in (65b) precisely because it follows a syllable containing an unstressable vowel, the /ə/ of /-alək-/. Although the /ə/ of this medial meets all of the conditions for pre-obstruent syncope, it is never deleted.

(65) a. kín-aləkí-kw-e  
large-hole-face-AI-(3)

'he has big eyes'

b. m<sup>á</sup>c-álək-ətón-e

bad-hole-mouth-AI-(3)

'he has a dirty mouth (uses bad language)'

The medial /-əcək-/ 'messy' contains one /ə/ which undergoes syncope regularly and one which is an exception to deletion:

(66) a. m<sup>án</sup>-cəkí-ptiné-ph-a-l

(3)-off-messy-hand-carry-DIR-3.OBV

'he knocks something out of the other's hand'

b. <sup>ásə</sup>w-əcək-ahté-t-ol

oblique-messy-be.located-3-33IN

'they (in.) are flopped over to one side'

In (66a) the first /ə/ of /-əcək-/ is unstressable and is therefore deleted by pre-obstruent syncope. The second /ə/ of this medial is stressable here, so its retention is regular. In (66b), however, the first /ə/ of /-əcək-/ is stressable, so the second /ə/ is unstressable. This status is confirmed by the fact that we again find two syllables between stresses. The second /ə/ of /-əcək-/ is not deleted in this form, however: here we have an exception to pre-obstruent syncope.

The root /kwəsəka-/ 'across' provides a parallel example of regular and irregular treatment of two schwas in the same morpheme, as we can see from the forms given in (62) above. Example (62a) shows that the first /ə/ of /kwəsəka-/ undergoes

pre-obstruent syncope regularly, giving us kwsəka- in this form. In (62b) however, the second /ə/ of /kwsəka-/ is retained on the surface before an obstruent, even though this vowel is clearly skipped over in counting syllables for alternating stress assignment.

Since one /ə/ in a morpheme may be an exception independently of others, it is clear that exceptionality cannot be treated as a property of a morpheme as a whole. We are thus led to attribute to individual segments the property of being an exception to a particular phonological rule.

Under the usual assumptions of generative phonology, this conclusion requires us to make use of some sort of diacritic device such as a rule exception feature. For concreteness, I will assume that particular occurrences of /ə/ in underlying forms are marked with a diacritic feature which blocks their deletion by pre-obstruent syncope. (In principle, I suppose, we might instead mark particular obstruents as exceptional non-triggers of syncope. This alternative should probably be rejected, however, since it would make it possible to mark individual obstruent-initial suffixes so that a preceding epenthetic /ə/ would be treated as an exception to syncope. As we will see in Chapter 7, the treatment of epenthetic /ə/ in syncope appears to be quite regular.)

Exceptions to pre-obstruent syncope are by no means rare. A number of examples with exceptional schwas were cited in Chapter 4, simply because the constraints on the distribution of unstressable /ə/ are most easily observed where syncope does not take place. The forms in (67) are typical. Both of the

underlined schwas are ignored in assigning alternating stress, yet neither is deleted.

- (67) a. nísi-katán-e  
two-year-AI-(3)  
'he is two years old'
- b. ál<sub>ə</sub>kwi-tawí-ye  
direction-fly-(3)  
'he flies in that direction'

Note also the exceptionally retained schwas in atóhk 'deer,' and také 'now,' where a must be unstressable since it remains unstressed in an initial syllable, and in man<sub>ə</sub>kwan 'rainbow,' where the first a is stressable and the second unstressable, as expected in word-initial /(C)a [+sonorant]a/.

In a class of examples which will figure in several discussions in following sections, a morpheme-initial /a/ irregularly fails to undergo deletion. This group includes several finals and several stems which may do service as finals: /-acassi-/ AI and /-acihte-/ II 'be a color,' /-atemi-/ AI 'cry,' /-at<sub>ə</sub>kwkwi-/ AI 'jump,' /akehkim-/ TA 'teach,' /akeləh-/ TA 'encourage to stay,' /akisi-/ AI 'read,' /akim-/ TA 'read, count, instruct,' and /api-/ 'sit.' Examples showing the retention of unstressable /a/ in these formatives are given in (68).

- (68) a. wá1-acá1sso  
 good-color-(3)  
 'he is of a good color'
- b. wá1-acihte  
 good-color-(3)  
 'it is of a good color'
- c. wéskew-atemi-t  
 easily-cry-3AN  
 'he who is always crying'
- d. ámik-atá1kko  
 up-jump-(3)  
 'he jumps up'
- e. ná1-akehkim-ke-kw  
 go-teach-PASS-22  
 'go (pl.) to school!'
- f. h-kis-akeloh-óko-1  
 3-past-encourage.to.stay-INV-3.OBV  
 'the other encouraged him to stay'
- g. níhtaw-akis  
 (1)-know.how-read  
 'I know how to read'
- h. á1-akim-ali-c  
 thus-instruct-2.OBJ-3  
 'have him tell you (sg.) (what to do)!'
- i. ó1-api-yá-ni-ya  
 (3)-good-sit-PL-SUBORD-33PROX  
 'they (pl.) sit comfortably (Subordinative)'

For the most part, a particular /ə/ either undergoes pre-obstruent syncope in all occurrences of a given morpheme or is a consistent exception to this rule. In a few morphemes, however, the treatment of /ə/ is variable. One case of this type was noted in 5.2.4, where we observed that the /ə/ of /-əka-/ 'dance' is an optional exception to syncope in the stem /pəm-əka-/. In other stems, the /ə/ of this final undergoes syncope regularly, so that we have, for example, mét-ka (finish-dance-(3)) 'he finishes dancing,' but not \*met-əka. See note 1 for comparable examples of idiosyncratic treatment of /ə/ in /-əkil-/ AI and /-əkikhwən-/ II 'be a size.'

The /ə/ of the medial /-əkisk-/ 'day' is usually treated as an exception to pre-obstruent syncope, but sporadically undergoes deletion, as we see in the following examples:

- (69) a. wəl-əkísk- t  
 good-day-II-(3)  
 'it is a good day'
- b. tən əl-əkísk-ət?  
 how thus-day-II-(3)  
 'How is the weather?'
- c. pém-kísk-ah-k  
 along-day-II-3IN  
 'today'  
 ("as the day goes along")
- d. mét-əkísk-ət  
 ~ mét-kísk-ət  
 finish-day-II  
 'the day comes to an end'

Finally, /ə/ appears to be consistently an optional exception to pre-obstruent syncope in /-əs-/ TA and /-əs-əm-/ TI 'by cutting edge':



- (70) a. tʰl-ʷs-óso  
 ~ tʰl-s-óso  
 ongoing-cut-REFLEX-(3)  
 'he is cutting himself (deliberately)'
- b. ht-ʷl-ʷs-ʷm-ʷn  
 ~ ht-ʷl-s-ʷm- n  
 ʷ-thus-cut-TI-ʷIN  
 'he cuts it (with a knife)'
- c. h-tʷm-ʷs-ʷm-ʷn  
 ~ h-tʷm-s-ʷm- n  
 ʷ-in.two-cut-TI-ʷIN  
 'he cuts it into two pieces'

### 5.2.8 Schwa Deletion I

If we adopt the CV theory of the stressable/unstressable distinction, then the rule of pre-obstruent syncope may be formalized as shown in (71). I will call this rule Schwa Deletion I, since four other rules of a similar form will be proposed in following sections of this chapter.

(71) Schwa Deletion I

② --> ∅ \_\_\_\_ [-sonorant]

To see how we can use this rule to account for the vowel/zero alternations that we find before obstruents, consider the derivations of h-sakh-ʷtʷmim-a-1 (ʷ-into.view-hire-DIR-ʷ.3.OBV) 'he appears, calls on the phone, etc. and hires the other' and ht-ʷp-

təmím-a-1 (3-go-hire-DIR-3.OBV) 'he goes somewhere and hires the other (and returns).' In the first example, the initial /ə/ of /-ətəmím-/ 'hire' is retained on the surface after a consonant cluster. In the second, the corresponding vowel follows a single consonant and is subject to syncope. The difference between these forms parallels that between písk-əlán (dark-rain-(3)) 'it rains so hard that it is dark or hard to see,' where the /ə/ of /-əlán-/ 'rain' is available for stress placement, and sók-əlán (pour-rain-(3)) 'it pours,' where this vowel is "invisible." This difference can be explained in the same way in both cases: V-Epenthesis is triggered by an unsyllabified second consonant in a cluster, but not by a syllabified post-vocalic consonant.

Suppose that we represent both schwas in /-ətəmím-/ as underlying floating vowels. The syllabified underlying form of hsákhətəmíməl will then be as shown in (72). (I ignore here the reduction of /-əl/ 3.OBV to /-l/ after /a/. For discussion of this process, see 8.1.3.)

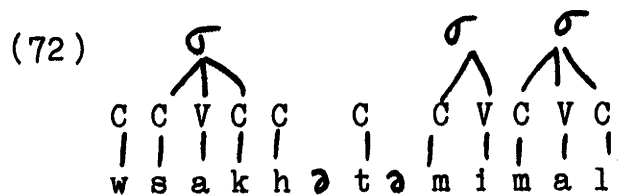

The leftmost unsyllabified C in (72) which is followed by a floating /ə/ is the C associated with the /h/ of /sakh-/. This C' triggers V-Epenthesis, which inserts a V-slot after it, linking the inserted slot with the initial /ə/ of /-ətəmím-/. Since the basic syllabification rules reapply throughout derivations, the result of applying V-Epenthesis to (72) is (73).

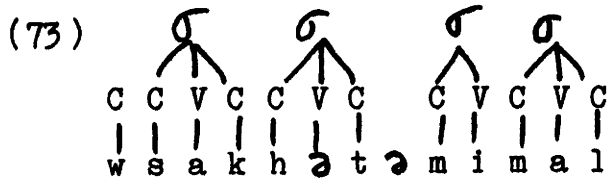

If (73) is now the input to Schwa Deletion I, no deletion will take place: the only floating /ə/ which remains in (73) is the second vowel of /-ətənim-/, which does not precede an obstruent. Since this vowel does not occur in a position in which it is subject to syncope, it is retained as an unstressable /ə/.

This is just the result that we need in order to derive secondary stress three syllables to the left of primary stress in hsakhatətmimal. Applying the Alternating Stress Rule and the Main Stress Rule to (73), we derive the metrical grid shown in (74a). Schwa Support and resyllabification then give us (74b).

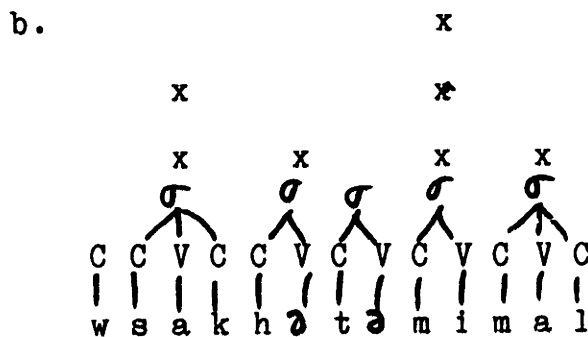
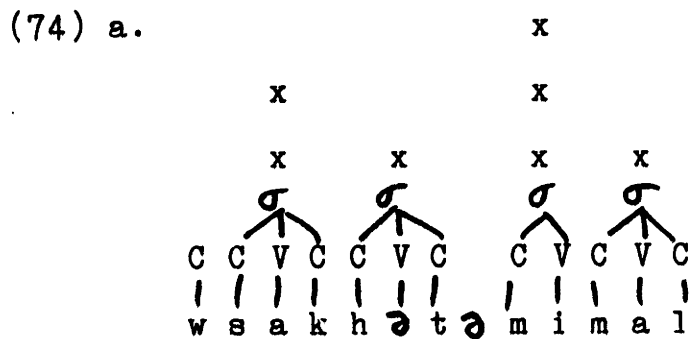

The initial /w/ of this form might be pronounced as such by an elderly Passamaquoddy speaker when the word follows a vowel, but most younger speakers will convert /w/ to h here.

If we make the same assumptions in setting up the underlying form of htaptəmímal, we will have the following representation (after initial syllabification):

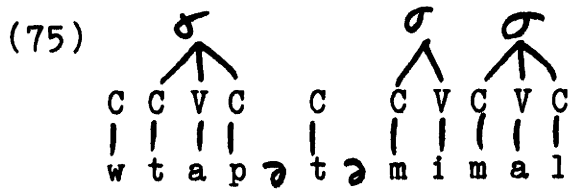

Here the leftmost C which is a potential trigger of V-Epenthesis is the one which is associated with the /t/ of /-ətəmim-/. V-Epenthesis adds a V-slot after this C, giving (76).

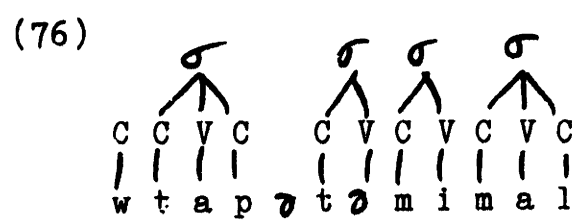

Again one /ə/ remains unstressable, but this time it is the first /ə/ of /-ətəmim-/. Since this /ə/ does precede an obstruent, Schwa Deletion I is now applicable. Application of this rule derives (77) from (76).

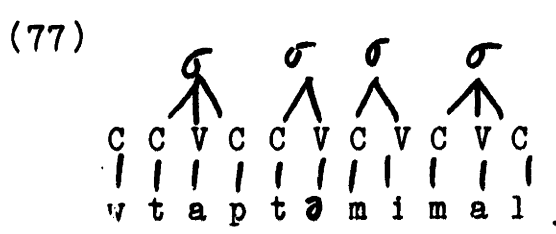

From this representation, the derivation of the surface form of htapt mimal is straightforward.

These two derivations illustrate the strategy that I will be pursuing in trying to account for the role of stressability in schwa/zero alternations: if we assume that the rules of syncope are operations which delete floating /ə/, then ordering these rules after the rules of V-slot epenthesis proposed in Chapter 4 will allow us to predict correctly that /ə/ will be deleted only where it would not be counted in assigning stress if it were retained on the surface.

### 5.2.9 Schwa deletion and V-slot epenthesis

The derivations of hsakhətə<sup>ˈ</sup>mɪmɪl and htaptə<sup>ˈ</sup>mɪmɪl given above suggest why certain clusters have the effect of preventing the deletion of a following /ə/ before an obstruent: the last segment of the clusters in question remains unsyllabified in underlying forms and triggers V-Epenthesis, so that the following /ə/ is no longer a floating vowel at the point in derivations when Schwa Deletion I is applicable. To account for the full range of conditions on pre-obstruent syncope, however, we must look further at the effects of V-Epenthesis and then consider the interaction of Schwa Deletion I with the other V-slot insertion rules of Chapter 4, Initial Syllable Epenthesis, Final Syllable Epenthesis, and S-HS Epenthesis.

First, consider the fact that syncope is permitted after clusters of /h/ and an obstruent, even though it is blocked after other sequences of non-syllabics. This special treatment of h-obstruent clusters follows directly from the fact that both

members of such clusters can be syllabified with a preceding vowel.

The basic syllabification rules which were motivated in 4.5.3 and 4.5.4 are repeated here as (78).

(78) a.

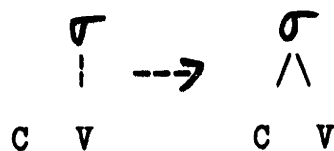

b.

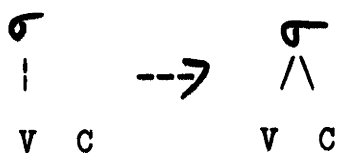

c.

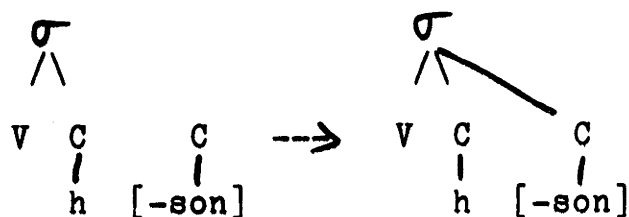

Given these rules, underlying /meht-əka-w/ (finish-dance-3) will be syllabified as shown in (79): the /ə/ of /-əka-/ is underlyingly unstressable, so both /h/ and /t/ in /meht-/ are syllabified with the /e/ which precedes them.

(79)

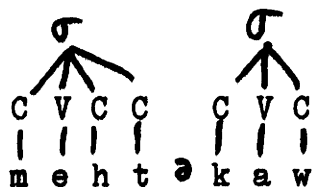

Since no C-slot remains unsyllabified here, V-Epenthesis is inapplicable. Schwa Deletion I eliminates the floating /ə/ of /-əka-/, giving /mehtkaw/. The deletion of /h/ before /CC/ and

the deletion of the third person suffix in final position then give mét-ka 'he finishes dancing.'

The situation is different where a floating /ə/ follows /hl/, as it does in (80a), the underlying representation (following the insertion of epenthetic /ə/) of the second word in the verb complex kt-əkwéci l-éhl-əkó'-w- n (2-try thus-TA-INV-NEG-SUBORD) 'he does not try to treat you (sg.) thus.' Final Syllable Epenthesis converts (80a) into (80b).

(80) a.

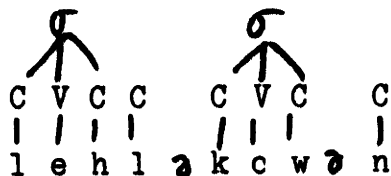

b.



Since /l/ is a sonorant, syllabification rule (78c) is not applicable here, and the /l/ of /-ehl-/ remains unassociated with a syllable node. This segment is therefore available to trigger V-Epenthesis, which turns (80b) into (81).

(81)

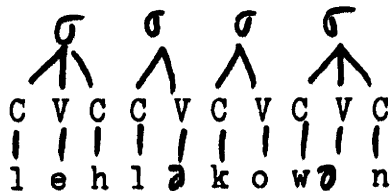

Once again V-Epenthesis bleeds Schwa Deletion I: the /ə/ of the inverse theme /-əkə-/ is no longer a floating vowel in (81), so it is not subject to syncope. The initial floating /ə/ in this representation is not in a position to undergo Schwa Deletion I,

but it fails to surface because it is subject to another syncope rule, which will be discussed in 5.9. The surface form l-éhl-əko'-w-ən also reflects the application of Penultimate Lengthening (3.3.3), which is applicable here because the /o/ of /-əko-/ is not derived from /ə/ by assimilation to the following /w/.

V-Epenthesis accounts for the role of alternating stressability in pre-obstruent syncope as well as for the restrictions imposed by clusters. We can see the relevant effects by comparing the derivations of kin-kíhkwən (large-size-(3)) 'it is big' and nátəm-əkihkwən (fairly.big-size-(3)) 'it is fairly big.' More complex examples involving alternating stressability will be discussed in the following subsection.

In kin-kíhkwən, the first /ə/ of /-əkihkwən-/ 'be a size' is subject to syncope, since it follows a stressable vowel and a single consonant. The corresponding vowel in nátəm-əkihkwən is retained on the surface because it is in a stressable position by alternating stressability. The syllabified underlying form of kin-kíhkwən is (82a). By hypothesis, the syncopating initial /ə/ of /-əkihkwən-/ is an underlying floating vowel. Final Syllable Epenthesis converts (82a) to (82b), but no further rules of V-slot insertion are applicable here, so the first /ə/ of /-əkihkwən-/ remains a floating vowel. Schwa Deletion I deletes this segment because it precedes an obstruent, and we are left with (82c).



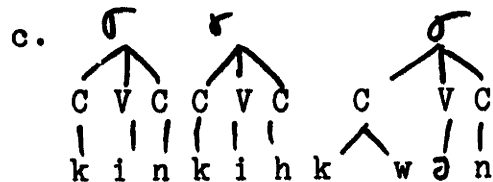
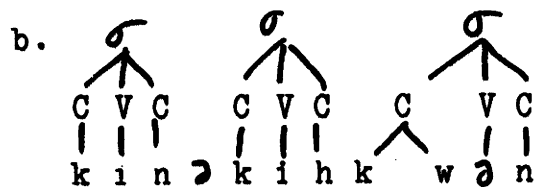
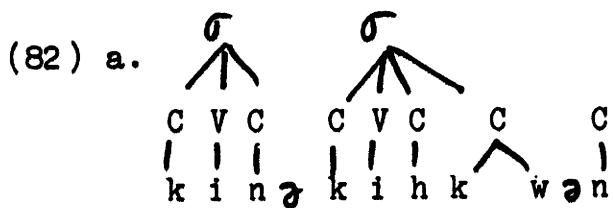

After the application of Final Syllable Epenthesis, natəm-əkíhkwən is represented as shown in (83a). In this case, one C remains unsyllabified -- the C associated with the /m/ of /natəm-/. This C' triggers V-Epenthesis just as if it were the unsyllabified second C in a cluster: as far as the applicability of V-Epenthesis is concerned, a /CəC/ sequence in which /ə/ is a floating vowel is equivalent to a consonant cluster. The output of V-Epenthesis is (83b).

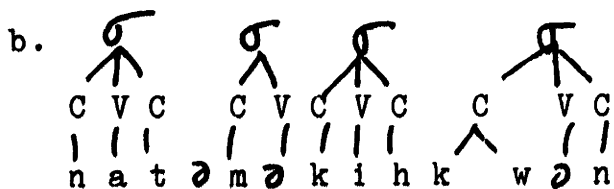
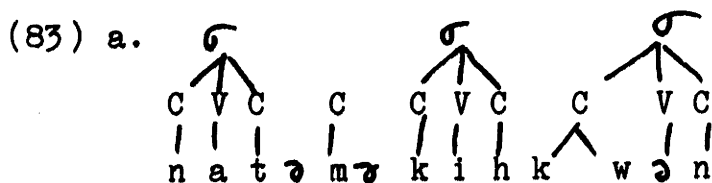

Now the initial /ə/ of /-əkíhkwən-/ is associated with a V-slot, so it is not subject to Schwa Deletion I. The /ə/ of /natəm-/

remains a floating vowel, but here Schwa Deletion I is inapplicable, since the following segment is a sonorant. This vowel is retained on the surface but is skipped over in figuring alternating stress, with the result that two surface syllables separate the stressed vowels of natəm-əkíhkwan.

Patterns of syncope in word-initial /((C)ə [+sonorant]ə / depart from what we would expect on the basis of alternating stressability alone, just as patterns of stress placement do. The reason, of course, is that Initial Syllable Epenthesis eliminates certain potential triggers of V-Epenthesis in such sequences. This is the case, for example, in the derivation of əl-kíhkwan (thus-size-(3)) 'it is big by so much.' The output of Final Syllable Epenthesis in the derivation of this word is (84a). Initial Syllable Epenthesis inserts a V-slot before the unsyllabified /l/ that we find here. Since this /l/ can now be syllabified with the preceding /ə/, as shown in (84b), it is no longer available to trigger V-Epenthesis. The result is that the initial /ə/ of /-əkíhkwan-/ remains unassociated with the CV tier and is eliminated by Schwa Deletion I, giving (84c).

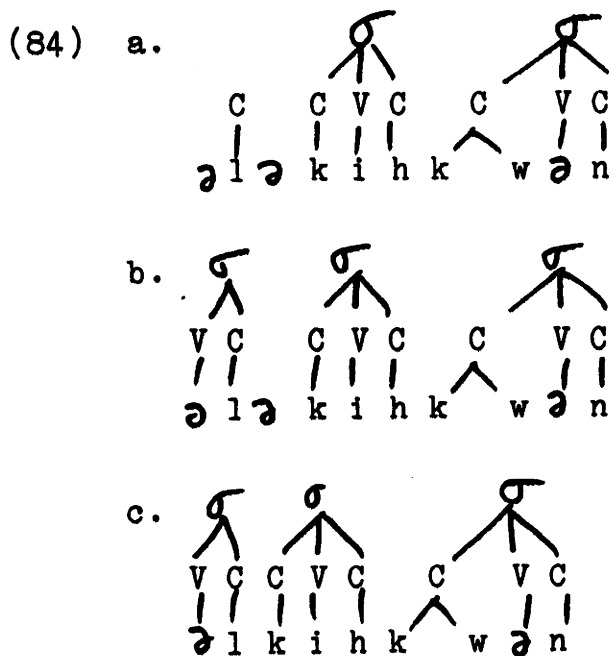

Note that ordering Initial Syllable Epenthesis before V-Epenthesis is crucial if this derivation is to proceed correctly: allowing V-Epenthesis to apply first would make the /l/ of /əlk-/ a trigger of this rule, which would give the initial /ə/ of /-əlkɪhkwən-/ a V-slot and prevent it from undergoing syncope. Early application of Final Syllable Epenthesis, on the other hand, is assumed here only for expository convenience. We would obtain the same results in all of the examples that we have looked at if we assumed that Final Syllable Epenthesis follows Initial Syllable Epenthesis or V-Epenthesis.

Final Syllable Epenthesis must, however, be ordered before Schwa Deletion I. It is the application of Final Syllable Epenthesis which prevents the deletion of /ə/ before word-final obstruents in forms like ətóhk-átəp (deer-head) 'deer's head' and cípiyahtək 'cross.' In suffixed forms of these words, where Final Syllable Epenthesis is not applicable, the corresponding segments are subject to syncope.

The derivations of cípiyahtəkw and the diminutive form cípiyatkw-is are shown in (85) and (86).

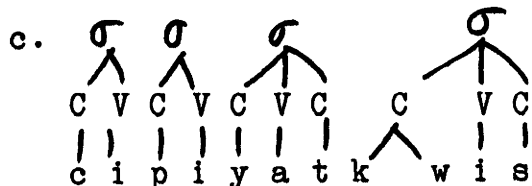
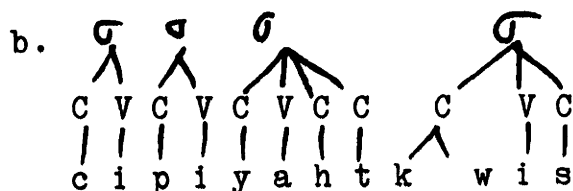
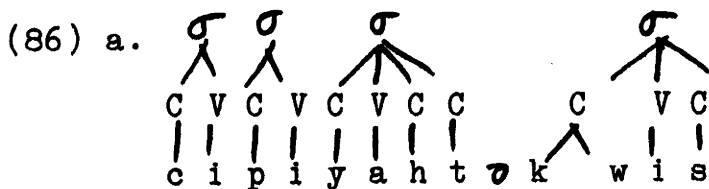
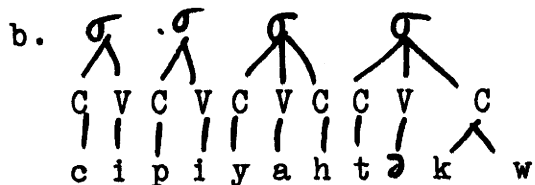
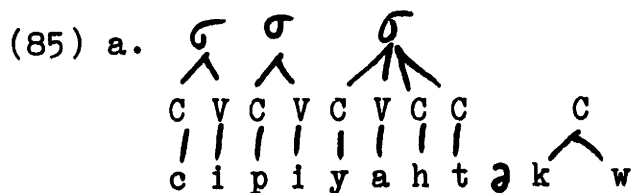

The syllabified underlying form of cípiyahtəkw is (85a). Final Syllable Epenthesis converts this structure to (85b), where no /ə/ remains unassociated with the CV tier and Schwa Deletion I is therefore inapplicable. With the addition of the diminutive suffix /-is/ in (86a), the floating /ə/ of /cípíyah t ə k w/ is no longer a trigger of Final Syllable Epenthesis. Since no other rule of V-slot epenthesis is applicable here either, this /ə/ remains a floating vowel and undergoes Schwa Deletion I, so that

we obtain (86b). The deletion of /h/ before /CC/ and the application of the stress rules give us the surface form cípiyátkwis.

We noted in 5.2.1 that /ə/ is subject to syncope before a surface word-final obstruent in forms which are derived through Final Vowel Deletion, so that underlying /imiya-w-əpi/, for example, gives surface ímiyè-w-p (pray-DA-liquid) 'holy water.' Such forms require us to state the constraint which syncope in words like cípiyahtəkw over representations at a stage in derivations prior to the loss of final vowels. In the present framework, we can accomplish this end simply by ordering Final Syllable Epenthesis before Final Vowel Deletion. The underlying form of ímiyè-w-p (following the morphologically governed mutation of the final vowel of /imiya-/ 'pray') is (87).

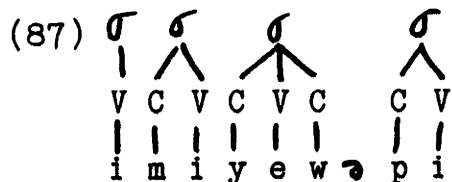

If this structure is the input to Final Syllable Epenthesis, no V-slot will be inserted, since the floating /ə/ of /-əpi/ 'liquid' does not precede a word-final consonant here. We thus correctly predict that this /ə/ will undergo Schwa Deletion I.

Given the hypothesis that the syncope rules of Passamaquoddy are rules which delete floating /ə/, postulating the rule of S-HS Epenthesis will guarantee that /ə/ will not be subject to syncope between /s/ and /hs/, so long as syncope follows V-slot epenthesis. After epenthetic /ə/ is inserted before the diminutive suffix /-hs-/, the representation of

wás-əss-is 'child (dim.)' is (88a). S-HS Epenthesis converts this structure into that shown in (88b).

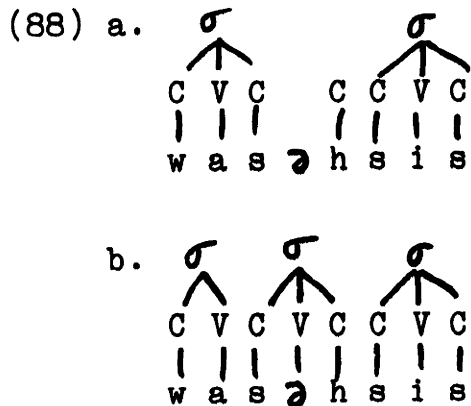

Even though /əhs/ ultimately surfaces as əss in this form, Schwa Deletion I can never apply here, since no floating /ə/ remains after the application of S-HS Epenthesis.

Note finally that inherently stressable schwas are not potential targets of Schwa Deletion I, since they are associated with V-slots in underlying forms. In the underlying representation of kətawi-tawiye (want-fly-(3)) 'he wants to fly,' for example, the first /ə/ of /kətaw-/ 'want' is linked to a V-slot:

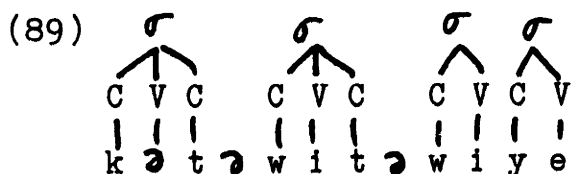

Schwa Deletion I is accordingly not applicable to this segment. The two floating schwas in (89) are followed by sonorants, so they do not undergo syncope either. Two unstressable schwas are retained on the surface, with the result that three syllables separate the stressed vowels of kətawitawiye.

We see, then, that it is not necessary to incorporate any of the conditions which determine stressability into our formal statement of pre-obstruent syncope. The application of Schwa Deletion I can be appropriately restricted simply by ordering this rule after the rules of V-slot epenthesis proposed in Chapter 4. Two other ordering relationships are also crucial if Schwa Deletion I is to account for the full range of cases of pre-obstruent syncope: Initial Syllable Epenthesis must precede V-Epenthesis and Final Syllable Epenthesis must precede Final Vowel Deletion. The rules which interact to produce the phenomenon of pre-obstruent syncope and the ordering relationships which must be imposed on them in the account given here are summarized in (90).

- (90)           Final Syllable Epenthesis  
                  Initial Syllable Epenthesis  
                  V-Epenthesis  
                  S-HS Epenthesis  
                  Schwa Deletion I  
                  Final Vowel Deletion

While the rules of V-slot epenthesis must precede both the stress rules and Schwa Deletion I, the relative order of stress assignment and syncope cannot be determined. Since the segments deleted by Schwa Deletion I are floating vowels, they will be invisible to the stress rules even if they are not deleted until after stress is assigned.

### 5.2.10 Extrametricality

An adequate account of pre-obstruent syncope in terms of the CV theory of stressability requires the same assumptions about extrametricality as the theory of stress presented in Chapter 4. In particular, word-initial unsyllabified C's must be designated as extrametrical, since they must be excluded as triggers of V-Epenthesis.

The need for this appeal to extrametricality can be seen most clearly where patterns of syncope change with the shifts in alternating stressability which result from prefixation. The derivations of ktákw-əno (over-AI-(3)) 'he stays over' and n-kátkw-ən (1-over-AI) 'I stay over' may serve as examples. The crucial difference between these forms is the site of syncope in underlying /kətəkʷ-/ 'over.'

Following the application of Final Syllable Epenthesis, the representation of ktákwəno is (91a). If the initial unsyllabified C in this representation is available to trigger V-Epenthesis, the first application of this rule will give (91b) and the second will yield (91c). Schwa Deletion I will then delete the second /ə/ of /kətəkʷ-/, since this segment remains unassociated with the CV tier, and we will derive the incorrect form \*kətkwəno.



(91) a.

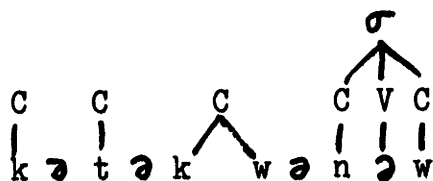

b.

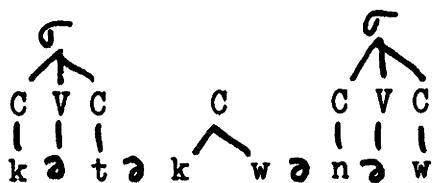

c.

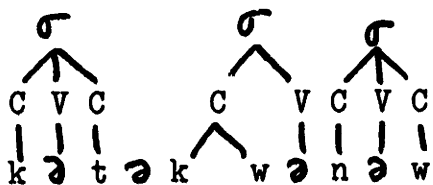

d.

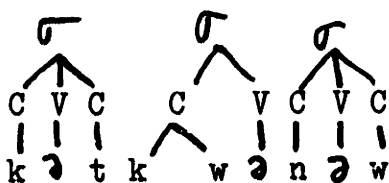

If, instead, the initial C' in /kətək-w-ənə-w/ is designated as extrametrical, as shown in (92a), then the leftmost C which can trigger V-Epenthesis is the C which is linked to the /t/ of /kətək-w-/. V-Epenthesis will therefore convert (92a) into (92b). Schwa Deletion I will now delete the first /ə/ of /kətək-w-/, giving (92c).

(92) a.

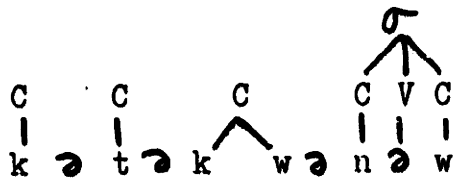

b.

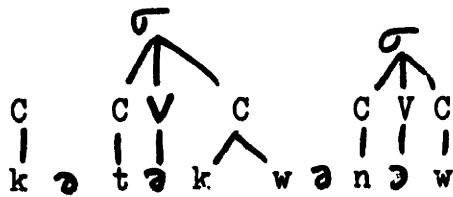

c.

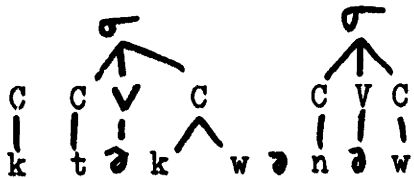

Stress assignment, Schwa Support, and the realization of final /əw/ as o will then correctly derive surface ktəkwan<sub>o</sub>.

Since only an element which is peripheral in the relevant domain may be extrametrical, the initial /k/ of /kətək w-/ cannot be excluded as a trigger of V-Epenthesis when it follows one of the personal prefixes. In (93a), the /n/ of the first person prefix is extrametrical instead. The first application of V-Epenthesis will therefore convert this structure into (93b). A second application of the rule will then derive (93c).

(93) a.

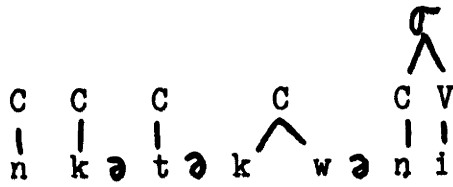

b.

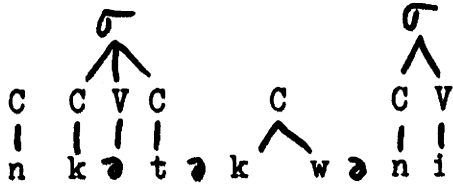

c.

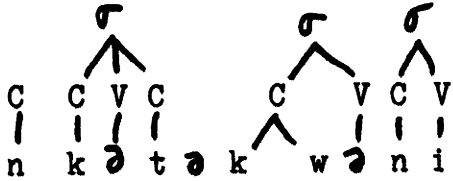

Here the second /ə/ of /kətəkwan/ remains a floating vowel, so it is deleted by Schwa Deletion I. The word-final /i/ of (93c) is eliminated by Final Vowel Deletion, and we are left with nkətəkwan, as required.

We see, then, that the patterns of syncope that we find in word-initial syllables are readily accommodated within the framework of the CV theory or stressability, but only if we maintain the assumption that initial C' is extrametrical.

### 5.2.11 The syllabification of /s/

We noted in 4.5.3 that two rules in addition to the basic syllabification rules of (78) are needed to account for the distribution of s in clusters. These are repeated here as (94).

(94) a.

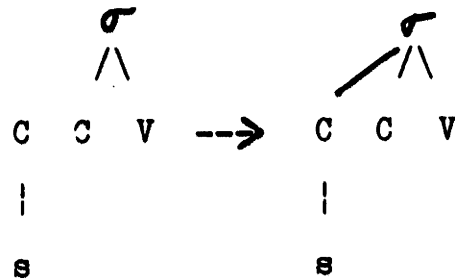

b.

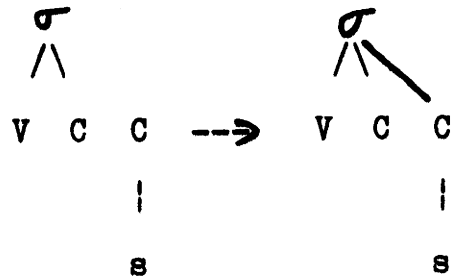

In 4.5.4 I argued that these rules for the syllabification of /s/ must be applicable only late in derivations, after the rules of V-slot epenthesis which determine the distribution of stressable and unstressable /ə/, if we are to account for the stress patterns of words like áps-ə́kil (small-size-(3)) 'he is small.' Once again the theory of syncope requires the same assumptions as the theory of stress.

Consider, for example, the word n-sáki-wán (1-urinate-NOM) 'my urine.' The unpossessed form ski-wán 'urine' shows that the first /ə/ of the stem /səki-wən/ is subject to syncope.<sup>3</sup> Thus the underlying form of n-sáki-wán must be (95a). Applying the basic syllabification rules gives us (95b). If rule (94a) is applicable to this structure, we will derive (95c): the C-slots associated with the /s/ and /k/ of /səki-/ are adjacent on the CV tier, and this is all that (94a) requires.

(95) a. C C C V C C  
 | | | | | |  
 n s ə k i w ə n

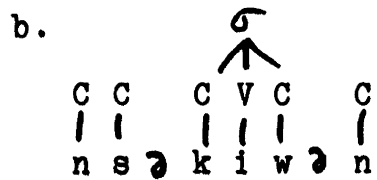
b.   
 C C C V C C  
 | | | | | |  
 n s ə k i w ə n

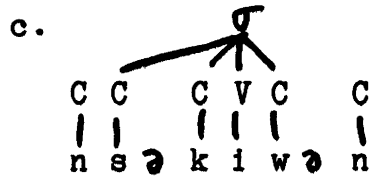
c.   
 C C C V C C  
 | | | | | |  
 n s ə k i w ə n

Final Syllable Epenthesis will convert (95c) to (96a), but no other rule of V-slot epenthesis is applicable here: the /s/ of /səkɪ-/ is not a possible trigger of V-Epenthesis, even though it is followed by a floating vowel, since it is already associated with a syllable node. Schwa Deletion I will therefore derive (96b) from (96a). The result is the ungrammatical form \*nskiwan.

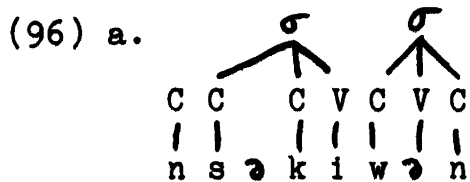
(96) a.   
 C C C V C V C  
 | | | | | |  
 n s ə k i w ə n

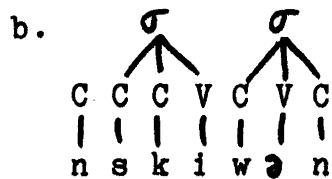
b.   
 C C C V C V C  
 | | | | | |  
 n s k i w ə n

The derivation will not go astray in this way, of course, if the formation of complex onsets is delayed until after the application of the V-slot epenthesis rules. Given this assumption, the result of resyllabification in the output of Final Syllable Epenthesis is (97a). Since the /s/ of /səkɪ-/

remains unsyllabified here, it triggers V-Epenthesis, giving (97b). No floating /ə/ remains in this representation, so Schwa Deletion I is inapplicable, and we correctly derive nsákiwən.

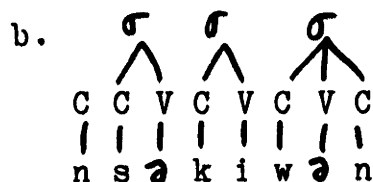
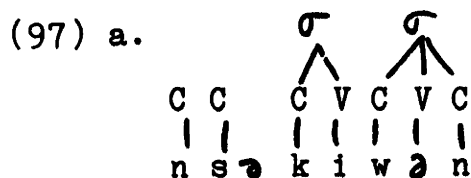

It is not sufficient, however, to delay only the formation of complex onsets. Both of the rules of (94) must be prevented from applying before V-Epenthesis. We can see this by looking at the derivation of təl-səkwe (ongoing-check.traps-(3)) 'he is checking traps.' The stem of this verb must be /ətəl-əsəkwe-/, since we find prefixed forms like nt-ətəl-əsəkwe-p n (1-ongoing-check.traps-11) 'we (du. exc.) are checking traps.' Thus the underlying form of təl-səkwe (ignoring the third person suffix) is (98).

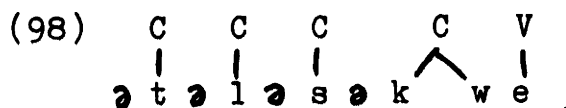

If (94a) as well as the basic syllabification rules may apply in initial syllabification, the result will be (99a). V-Epenthesis will then derive (99b). (Recall that the /t/ of /ətəl-/ cannot be extrametrical because it is not marginal on all tiers.)

(99) a.

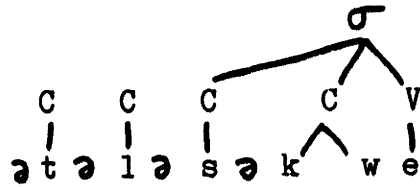

b.

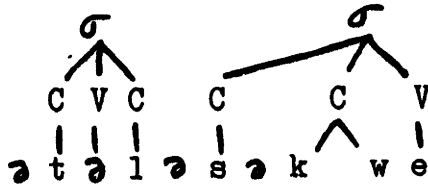

No C-slot remains unsyllabified, so V-Epenthesis is not applicable again. Three schwas remain unassociated with the CV tier and are therefore subject to Schwa Deletion I. Thus we derive \*təlskwe, not təlsəkwe as required.

Suppose, now, that (94a) does not apply in initial syllabification, or at any point in derivations prior to the application of V-Epenthesis. The initial syllabification of təlsəkwe will then be as shown in (100a). The application of V-Epenthesis and the basic syllabification rules to this structure gives (100b). If (94b) is allowed to apply at this point in the derivation, the result will be (100c).

(100) a.

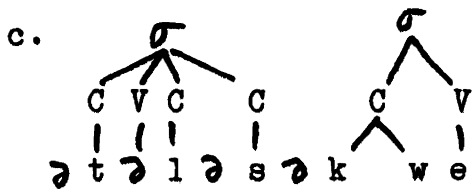
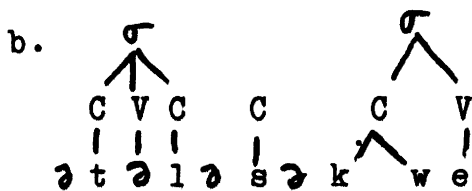

Here again no C-slot remains unsyllabified to trigger a second application of V-Epenthesis. We again derive the ungrammatical form \*təlskwe.

If the application of both (94a) and (94b) is delayed until after all applications of V-Epenthesis, the derivation of təlsəkwe will proceed correctly. Initial syllabification gives (101a). V-Epenthesis now applies twice. It is triggered first as before by the /t/ of /təl-/, then by the /s/ of /-əsəkwe-/, since this segment remains unsyllabified after reapplication of the basic syllabification rules in the wake of the first application of V-Epenthesis:



(101) a.

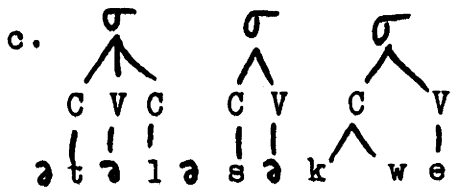
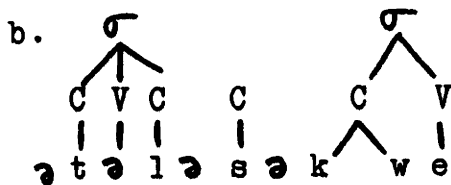
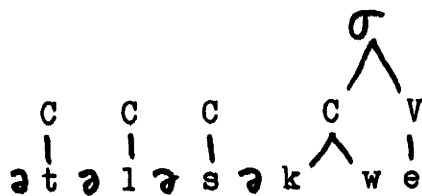

Only the first and third schwas in the resulting representation remain unassociated with V-slots. It is therefore just these two segments which are deleted by Schwa Deletion I, just as we expect on the basis of the principle of alternating stressability. We are left with surface tálsəkwe, as desired.

The proposed distinction between "basic syllabification rules" and the rules which are specific to /s/ solves the problem raised by forms like nsəkíwən and tálsəkwe by keeping /s/ unsyllabified where it is followed by a floating /ə/ until V-Epenthesis can supply a slot for the floating vowel. Other solutions to the problem might also be proposed.

For example, we might impose a condition like (102) on rules of syllabification, therefore directly excluding unwanted applications of the rules in (94).

(102) If two adjacent slots in the CV tier are  
incorporated into the same syllable, then  
the segments associated with them must also  
be adjacent.

A proposal of this kind is open to a variety of objections, however. First, it claims generality for the problem at hand, while in fact only the syllabification of /s/ is involved. More seriously, it undermines the proposed explanation for the role of /ə/ in stress placement, which is based on the idea that floating /ə/ is invisible to the rules of syllabification. Finally, we will see in 8.4.5 that certain applications of the basic syllabification rules must violate (102). I will therefore continue to assume that the syllabification rules of Passamaquoddy are divided into two sets with sharply different ordering properties.

Note finally that the delayed syllabification of some occurrences of /s/ requires us to maintain the "phoneme-driven" formulation of V-Epenthesis proposed in Chapter 4, which is repeated here as (103a). We cannot insert V-slots without reference to the location of floating schwas, as an alternative rule like (103b) would do, without making incorrect predictions about the derivations of items like kspíson 'belt' and kín-  
ap<sup>h</sup>sk-əso (large-round-AI-(3)) 'he is fat.'

- (103) a.            V   C'
- (ə) ---> | / |
- ə   X    \_\_\_
- b.    ϕ ---> V / C'    \_\_\_

Possessed forms like h-káspison (3-belt) 'his belt' show that kspison is derived by syncope from /kəspison/, where /ə/ is an underlying floating vowel.<sup>4</sup> Given the assumption that the syllabification rules which are specific to /s/ apply only late in derivations, the syllabified underlying form of kspison must be (104a). Initial unsyllabified /k/ in this structure will be marked as extrametrical, so it will not trigger V-Epenthesis regardless of how the rule is formulated. Given (103b) as the statement of V-Epenthesis, however, the C associated with the following /s/ will trigger V-Epenthesis, since it has not yet been syllabified. The result is (104b). Schwa Deletion I will delete the /ə/ before this /s/, so that we will ultimately obtain (104c). This is incorrect: kspison is a two-syllable word.

(104) a.

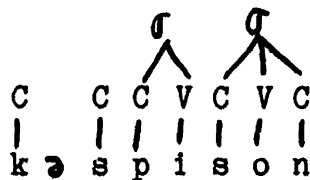

b.

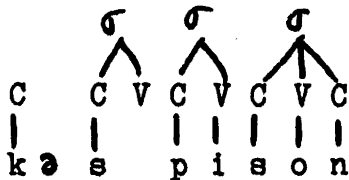

c.

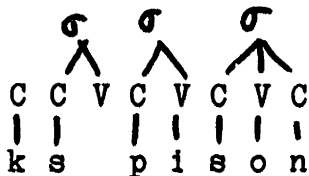

The situation is even worse in the case of kín-apsk-əso 'he is fat.' The last element of the stem in this word is the common AI final /-əsi-/. Numerous other words containing this final show that its initial /ə/ may undergo syncope: kín-takw-so (large-sound-AI-(3)) 'he talks big.' Thus the syllabified underlying form of kínapskəso must be (105a), ignoring the suffix phonology. The leftmost extrasyllabic C in (105a) is the C associated with the /s/ of /-apsk-/, which remains unsyllabified by hypothesis. If V-Epenthesis is formulated as in (103b), this C' will trigger it, giving (105b). Schwa Deletion I will then turn (105b) into (105c).

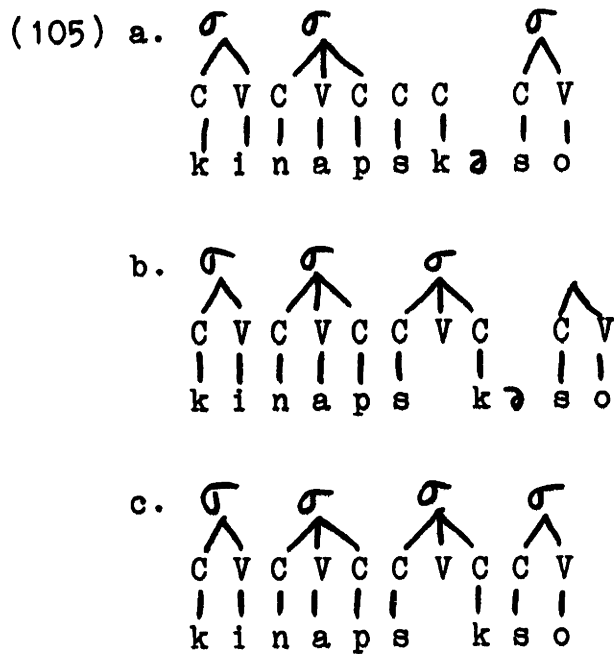

Now we have deleted the first vowel of /-əsi-/ when we need to retain it, while introducing a syllable without a vowel.

The derivations of kspɪson and kɪnapskəso have both come to grief in the same way: we have allowed V-Epenthesis to introduce a V-slot where there is no floating vowel to be linked with it. By adopting the formulation of V-Epenthesis proposed in 4.5.2, which requires a floating /ə/ in the triggering environment, we avoid this problem. Given rule (103a), the underlying form of kspɪson contains no trigger of V-Epenthesis. Schwa Deletion I correctly derives (106b) from (106a). The late syllabification of /s/ then gives (106c), in which only initial /k/ remains unsyllabified.

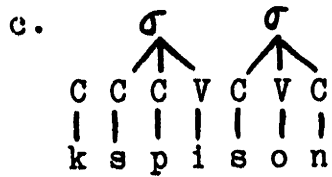
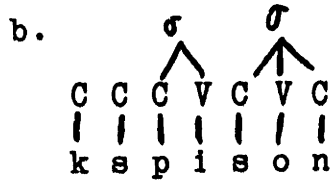
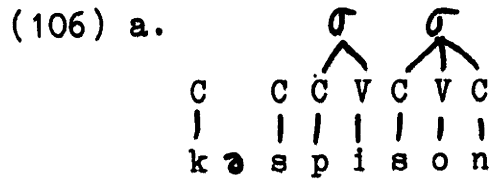

The derivation of kinapskəso proceeds as shown in (107). Only the /k/ of /-apsk-/ triggers V-Epenthesis. This application of the rule provides a slot for the /ə/ of /-əsi-/, which is accordingly retained on the surface. Again the derivation is completed by the late application of syllabification rule (94a).

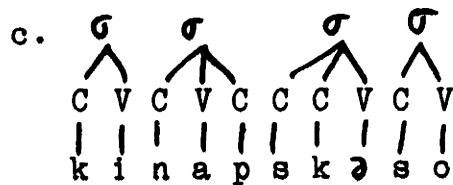
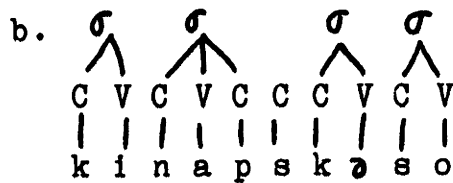
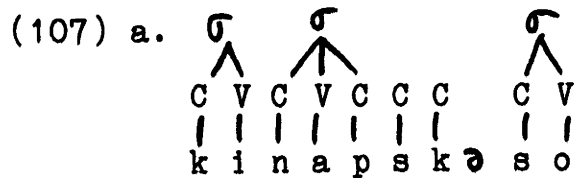

The phoneme-driven version of V-Epenthesis receives some independent support from forms in which syncope takes place before geminates, although it is possible that an adequate account of the blocking effect of geminates might prevent the application of V-Epenthesis here in any case. Comparing pkíhkən 'fishhook' with the possessed form mákkíhkən ((3)-fishhook) 'his fishhook,' we can see that the former is derived by syncope from underlying /mǝkkihkən/. (The change of /m/ to p is a regular reflex of Initial Devoicing.) Thus the underlying representation of pkíhkən, after Final Syllable Epenthesis, is (108).

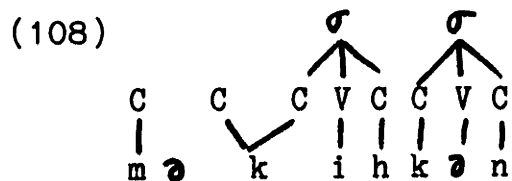

Now initial unsyllabified /m/ is extrametrical here, so it will not trigger V-Epenthesis under either formulation. But if V-Epenthesis is stated as in (103b), and no independent principle prevents its application in geminate structures, then it will insert a V-slot after the first C associated with the geminate /k/ in (108), clearly an undesirable consequence:

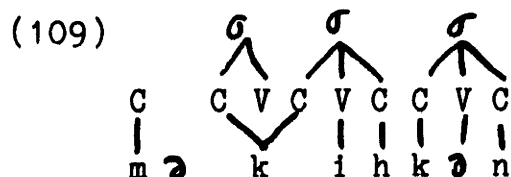

Our original statement of V-Epenthesis encounters no such difficulties: the C' in question is not followed by a floating /ǝ/, so the rule is not applicable. The one floating /ǝ/ in (108) is eliminated by Schwa Deletion I, since it precedes an

obstruent, with the result shown in (110a). Initial Devoicing gives p for /m/. The following geminate may be assumed to undergo a shortening process, since geminates are not distinct from single segments after a non-syllabic. (See 5.3.2 for some discussion of degemination in this environment.) The output of these operations is (110b).

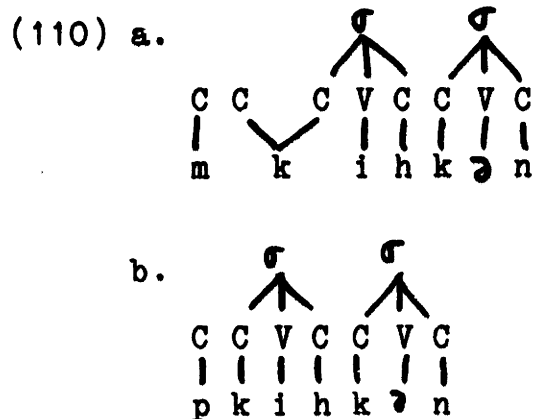

Many other examples attest to the generality of syncope before geminates: képp-ətə-k 'when it was frozen' (with Initial Change), but kp-ətan 'it is frozen' (stem /kəpp-ətən-/ close-freeze); n-pəkkwəm-om 'my ice,' but pkwəm 'ice' (stem /pəkkwəm/); n-kəssa-hə-pən 'we (du. exc.) go in,' but kse-he 'he goes in' (stem /kəsse-hə-/ in-go).

#### 5.2.12 Syncope after geminates?

The syllabification rules which I have proposed for Passamaquoddy make no distinction between geminate and non-geminate clusters. They do, however, include a special provision which permits syllable-final clusters of /h/ and an obstruent. Since V-Epenthesis is triggered by unsyllabified C-slots, we are



led to predict that /ə/ will always be treated as stressable where it follows an underlying geminate, including /ss/, but that unstressable /ə/ should be permitted after ss which is derived from /hs/.

The reason is that the second C-slot associated with an underlying geminate cannot be syllabified with a preceding vowel and is therefore available to trigger V-Epenthesis, whereas both C-positions associated with underlying /hs/ can be syllabified with a preceding vowel, and /ss/ derived from /hs/ can inherit this syllabification.

Thus we find penultimate stress in cán-essó-w-ək (stop-move-3-33PROX) 'they (du.) stop,' even though I-Mutation presumably derives a floating /ə/ from the final /i/ of /-essi-/ 'move' in this form, as shown in (111).

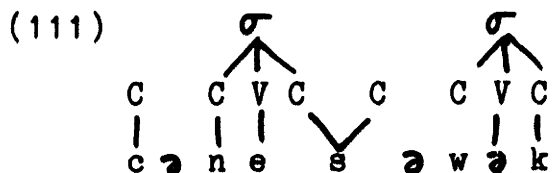

The unsyllabified second C of the geminate /s/ in this representation triggers V-Epenthesis, making the penultimate vowel of cánessówək available to receive stress:

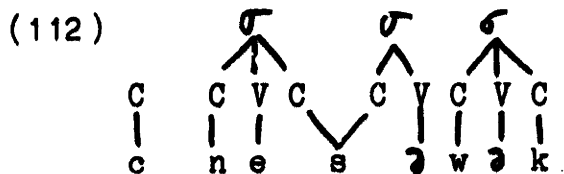

Stressable /ə/ before /w/ is then realized as o.

We find antepenultimate stress in cánə-ssəmo (stop-drink-(3)) 'he stops drinking,' because ss in this form

represents /hs/ in underlying /cəni-hsəmi-w/. The output of I-Mutation and Final Syllable Epenthesis in the derivation of this word is syllabified as shown in (113a). Now we have been operating with syllabification rules, not with well-formedness conditions on syllable structure. Thus there is nothing in the proposed analysis which will prevent the syllabification of /ihs/ in (113a) from being carried over after this sequence is converted to /əss/, as shown in (113b).

(113) a.



b.

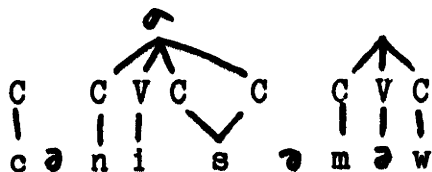

We therefore predict, correctly, that the penultimate /ə/ in cəniəsəmo will remain unstressable, since V-Epenthesis will not be applicable at any point in the derivation of this form.

Given the relationship between stressability and syncope which has been demonstrated above, we expect that /ə/ will always be maintained into surface forms after geminates, except in cases where /ss/ is derived from /hs/. For the most part, this is the case. Thus, for example, the underlyingly unstressable /ə/ of /-əsit(e)-/ 'foot' is retained after underlying /ss/ in kəs-s-əsitə-n-s (wash-foot-by.hand-REFLEX) 'wash (sg.) your feet!' Nonetheless, there are a few problematic items in which syncope does appear to take place after underlying geminates. The

clearest examples of this type involve the deletion of underlyingly unstressable /i/. Discussion of these cases must be postponed until 6.4.4. Here I summarize the facts concerning two possible examples of the deletion of /ə/ after geminates. In both of these cases, alternative analyses which do not involve exceptional syncope appear plausible.

A comparison of h-káppi-htané-n-a-l (3-close-nose-by.hand-DIR-3.OBV) 'he holds the other's nose shut' and h-káp-toné-n-a-l (3-close-mouth-by.hand-DIR-3.OBV) 'he covers the other's mouth with his hand' suggests that the /ə/ of /-əton(e)-/ 'mouth' is deleted after /pp/ in the latter. (Since any non-syllabic is long as the first member of a cluster, we will have phonetic [p·] in this form regardless of the underlying length of this segment.) But in fact it seems that /kəpp-/ 'close' has an alternate underlying form /kəp-/, so this analysis is not certain. For example, if we insert the medial /-aləkittiye-/, indicating anger or intensity, into h-káp-toné-n-a-l, we may have either h-kəpp-aləkittiye-toné-n-a-l or h-kəp-aləkittiye-toné-n-a-l, the former with pp, the latter with p.<sup>5</sup> Given underlying /kəp-/, we can derive h-káp-toné-n-a-l without postulating syncope after /pp/. Indeed, the existence of an alternate (although apparently less common) form h-kəpp-ətoné-n-a-l, in which the /ə/ of /-əton(e)-/ is stressable and does not undergo syncope, would appear to confirm this approach.<sup>6</sup>

The plural of éskətássek 'cucumber' is éskətásék-il, apparently reflecting the deletion of /ə/ between /ss/ and /k/. Now the use of the participial suffix /-il/ 33IN with this noun, rather than the usual nominal suffix /-əl/, shows that it is a

verbal form in origin. Presumably it reflects an earlier diminutive participle with the underlying form \*/esk-ət-asihs-ən-k/ (raw(?)-eat-II-DIM-3IN), meaning something like 'that (dim) which is eaten raw.' Of course if we could derive əss from /ihs/ in a synchronic analysis of éskátasássak, then syncope in suffixed forms of this word would not be problematic: the representation of éskátasáskil in the input to V-Epenthesis would be something like (114), so syncope would be expected here.

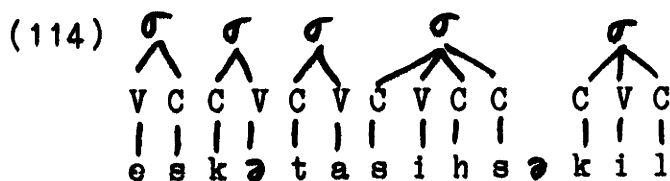

No verb \*esk-ət-aso or \*sk-ət-aso is attested in the contemporary language, however, and in any case the meaning of éskátasássak has drifted quite far from any ordinary verbal notion. Thus it seems quite arbitrary to postulate /ihs/ in the underlying form of this noun. Given these difficulties, it may be best simply to analyze /eskátasásk-/ as an irregular non-final allomorph of the stem /eskátasássak/, so that the two are not in fact related by syncope. One elderly consultant (S.G.) uses a singular form éskátasásk which appears to reflect the kind of generalization of one stem alternate at the expense of another that we might expect on the basis of the allomorphy solution. However this may be, it seems clear that the apparent case of syncope after underlying /ss/ that we find in éskátasáskil does not provide a serious counterexample to the analysis of syncope proposed above.

### 5.2.13 The diacritic alternative

I noted in the introduction to this chapter that a reasonably straightforward account of syncope can be given in any framework which provides us with a way to distinguish between stressable and unstressable vowels. In the diacritic theory of stressability which was developed in 4.3, this distinction is modeled by introducing a diacritic feature [strong] and a set of rules which adjust its values in particular contexts. These rules are analogous to the rules of V-slot insertion in the CV model, and they will allow us to identify the same set of vowels as unstressable in all of the examples that we have considered up to this point. (Some differences in the predictions of the two theories will be discussed in Chapter 8.) Under the assumptions of the diacritic theory of stressability, then, the analogue of Schwa Deletion I can be stated as rule (115).

$$(115) \quad \text{ə} \quad \text{--->} \quad \emptyset / \text{ \_\_\_ } [-\text{sonorant}] \\ \text{[-strong]}$$

Now (115) is no more complicated than Schwa Deletion I. Nonetheless, an account which incorporates a rule of this type seems fundamentally inadequate. The use of a diacritic feature to distinguish two classes of segments implies that there is no phonological basis for the distinction. It must therefore be regarded as highly surprising if several different phonological processes make the same distinction. But we have already seen that stress assignment must distinguish between stressable and

unstressable /ə/. All five of the syncope rules which are motivated in this chapter must also be sensitive to this difference. A rule deleting /h/ will be discussed in 5.8.2 which requires an unstressable /ə/ in its environment. The vowel elision rule formulated in 8.2 deletes an unstressable vowel. Unstressable vowels receive special treatment in Initial Change, as we will see in 9.2. Clearly the distinction between stressable and unstressable vowels cannot be phonologically arbitrary.

The theory of syncope which Sherwood (1983b:32-35) has proposed for Maliseet is couched in terms of a diacritic distinction between strong and weak vowels and is therefore open to the same criticisms as a theory based on the account of stressability given in section 4.3 of this work. Sherwood in fact proposes eight rules which delete weak vowels in various environments. (I count as two rules one pair which he collapses by means of braces but which share no part of their environments.) Two of these rules could undoubtedly be eliminated if his account of epenthesis is modified, since neither produces any surface alternations and both serve only to eliminate putative epenthetic vowels in the environment of particular morphemes. The remaining system would still be quite complicated, however. For example, the rule which accounts for most of the cases of pre-obstruent syncope in Sherwood's analysis is stated as follows:

$$(116) \quad \overset{WK}{a} \dashrightarrow \emptyset \quad / \left. \begin{array}{c} \# \\ \\ V(h) \end{array} \right\} C \text{ --- } C^{obs} V$$

(obs = obstruent)

The complexity of this formulation is due to the fact that it directly stipulates that syncope is permitted after a single non-syllabic or a cluster of the form /hC/, but not after other clusters, and that /ɔ/ is not subject to syncope when it is the last underlying vowel in a word. (No provision is made for the special status of /hl/ because Sherwood derives all occurrences of hl from /həl/, despite the fact that hl never alternates with həl on the surface.) These constraints must be incorporated into the formal statement of pre-obstruent syncope in Sherwood's system because he recognizes only a version of the principle of alternating stressability as a determinant of the distribution of strong and weak vowels. (The same conditions must be repeated in some of his other syncope rules.)

Sherwood's statement of alternating stressability is given in (117).

(117) In a sequence of syllables each containing the short vowels /a/ or /ə/, vowels in odd-numbered syllables are weak and subject to syncope. Syllable counting begins over after each long vowel. (1983:32)

This formulation assumes an underlying system of four "long" vowels /i, e, o, a/ and two "short" vowels /ə/ and /ǎ/, where /ǎ/

is an abstract morphophoneme which underlies all occurrences of a which alternate in syncope and some occurrences of ə which do not.

There are two basic problems with this proposed vowel system. First, the underlying distribution of long and short vowels which it presupposes is not related in any way to the phonetic distribution of long and short vowels in either Maliseet or Passamaquoddy. (In fact, all underlying length distinctions will presumably have to be eliminated before phonetic length is determined, since long vowels in both dialects reflect the application of lengthening rules, not shortening rules, as we saw in 3.3.) Second, all occurrences of /ǎ/ are subject to neutralization rules: /ǎ/ always merges with /a/ before /hC/ and with /ə/ elsewhere.

The use of an abstract underlying segment may be justified in cases in which more than one rule makes the same abstract distinction. Sherwood apparently assumes that his use of /ǎ/ can be justified on these grounds, although he does not explicitly make such an argument. (To a large extent, his analysis recapitulates the history of the language. For some remarks on of the history of the Passamaquoddy vowel system in this connection, see 6.5.)

Deriving some occurrences of ə from /ǎ/ appears at first to have this kind of justification in Sherwood's system. His rule which accounts for syncope before obstruents, rule (116) above, deletes /ə/ but not /ǎ/. By deriving some occurrences of surface ə from /ǎ/, he is able to account for forms in which unstressable ə is retained before obstruents without introducing the exception



features that I postulated in 5.7: any occurrences of  $\text{ə}$  which appear to be exceptions to syncope are simply derived from  $/\text{ǣ}/$ .<sup>7</sup>

Now (116) does not account for cases where initial  $/\text{ə}/$  alternates with zero, which are instead handled by (118), a diacritic version of the rule deleting initial unstressable vowels which I will formulate within the CV framework in 5.9. Note that this rule also deletes  $/\text{ə}/$  but not  $/\text{ǣ}/$ .

(118)  $\text{ə}^{\text{WK}} \text{ ---} \rightarrow \emptyset / \# \text{ \_\_\_ } \text{C}$

Since certain morpheme-initial schwas can appear either initially or medially in a word, some schwas are potential targets of both (116) and (118), in different forms. If apparent exceptions to one rule are also apparent exceptions to the other, within this class of cases, then this fact can be explained by deriving the non-alternating schwas from  $/\text{ǣ}/$ . We would then appear to have justification for postulating abstract  $/\text{ǣ}/$ , since two rules would make the same distinction between two kinds of surface schwas.<sup>8</sup>

As it turns out, however, some occurrences of  $/\text{ə}/$  are exceptions to pre-obstruent syncope but not to syncope in word-initial position. Thus, for example, the  $\text{ə}$  of  $\text{əkəkɪm-}$  'teach' is retained medially in forms like  $\text{nát-əkəkɪm-â}$  (go-teach-3PASS) 'he goes to school,' but is dropped at the beginning of a word, as in  $\text{kékɪm-â}$  (teach-3PASS) 'he is taught.' (I return to this matter in 5.9.) This fact seems to me to show quite conclusively that the class of segments which are exceptions to pre-obstruent syncope, unlike the class of unstressable vowels, is phonologically arbitrary. I therefore reject Sherwood's proposal

to derive non-alternating a from /ǎ/. His use of /ǎ/ as the source of syncope a will be discussed in 6.5.

#### 5.2.14 The metrical alternative

An account of syncope in Passamaquoddy which is based on a metrical theory of stressability like that developed in 4.4 is not open to the same kind of criticism as an account which uses a diacritic feature [strong], since it can provide a principled basis for a distinction between stressable and unstressable vowels: all stressable vowels, in this theory, occupy more prominent position in metrical structures than unstressable vowels. If all degrees of metrical prominence are interpreted as degrees of stress, we can say that only stressless vowels are subject to syncope -- surely a natural condition to place on deletion rules.

Despite the apparent naturalness of the syncope rules themselves in this account, an important property of the system of syncope as a whole remains unexplained. The lowest level of metrical structure in the theory of 4.4 is constructed by the rule of Subfoot Formation, whose application is governed by the distribution of accents, some of the lexical, some assigned by rule. Because the rule which assigns accents to vowels which follow clusters other than /hC/ has no intrinsic connection with the rules of syllabification -- or any other aspect of the phonology of Passamaquoddy -- it is essentially an accident in this analysis that vowels which follow these clusters always bear

some degree of stress and are therefore prevented from undergoing syncope. We have already seen, in the introduction to this chapter, that the rules of syllabification do not function in any meaningful sense as a system of output conditions on syncope. Thus we have no explanation, within the metrical theory, for the fact that the conditions on syncope have the effect of preventing the derivation of any surface sequences which would violate the constraints on surface syllabification imposed by the Unsyllabified Consonant Filter, rule (154) of Chapter 4.

The observed relationship between the principles which govern syllabification and the conditions on syncope follows directly from the assumptions of the CV theory. Only unstressable /ə/ is subject to syncope. But underlyingly unstressable /ə/ becomes stressable where the rules of V-slot epenthesis are applicable. The rule of V-Epenthesis is directly conditioned by syllabification: it inserts a V-slot to support a floating vowel just in case a preceding non-syllabic is unsyllabifiable without this slot. The result is that syncope is never permitted where deletion would leave a non-syllabic in a position where it could not be incorporated into a syllable. The only exceptions, both for V-Epenthesis and for the Unsyllabified Consonant Filter, involve word-initial non-syllabics. The explanation is the same in both cases: word-initial C' is extrametrical.

The conditions on syncope are more restrictive than the conditions on surface syllabification: some schwas are retained, even though the surrounding non-syllabics would be syllabifiable if they were deleted. This effect has two sources. First, some

occurrences of /s/ which could in principle be incorporated into syllable-initial or syllable-final clusters nonetheless trigger V-Epenthesis, because the rules which syllabify /s/ in clusters apply only late in derivations. This is why syncope does not take place in the derivation of a word like áps-ǎkil (small-size-(3)) 'he is small,' even though there would be nothing anomalous about surface psk if the derivation led to \*aps-kil instead. Second, a /CǎC/ sequence, where /ǎ/ is a floating vowel, is equivalent to a cluster in triggering V-Epenthesis. Thus pre-obstruent syncope is blocked in a form like nátǎm-ǎkil (fairly.big-size-(3)) 'he is fairly big,' even though there would be nothing anomalous about surface mk if syncope were permitted to derive \*natǎm-kil.

The CV theory of stressability allows us to understand how syncope and syllabification are related, while the metrical account provides no insight into this connection. The CV theory is therefore to be preferred for its greater explanatory force. We would have more confidence in this decision, however, if it could be shown that there are also empirical grounds for preferring the CV alternative. An argument of this kind is offered in Chapter 8.

### 5.3 Devoicing of initial sonorants

A variety of rules which affect word-initial non-syllabic sonorants are discussed in this section. An understanding of these processes is important for the larger issue of stressability primarily because the alternations which they produce obscure the effects of syncope in many words. Three of

these rules also provide evidence which bears on the correctness of the analysis of syllabification in Passamaquoddy which was offered in Chapter 4, since they are best formulated so that their targets are unsyllabified C's.

The most important of the rules that I will consider here is a process of Initial Devoicing. Underlying /m/, /n/, and /w/ are subject to devoicing before an obstruent at the beginning of a word. Since the other non-syllabic sonorants of the language do not occur in this position, devoicing can be formulated as a general rule affecting non-syllabic sonorants. The frequency with which this rule is applied varies greatly according to the identity of the target segment, the details of the segmental environment, and the age of the speaker.

The voiceless sonorants derived by this process usually undergo further modification: voiceless /m/ is replaced by p; voiceless /n/ and /w/ become h, which then has a variety of phonetic realizations according to context. Voiceless m may still be heard from elderly speakers, however, and voiceless w is apparently also still possible for some Passamaquoddy speakers. (It is well attested in Maliseet.)

In the speech of my oldest consultants, the /w/ of the third person prefix optionally triggers the rounding of a following /k/ to /kw/. This rule is no longer applied by middle-aged and younger speakers and has presumably been dropped from the grammars of speakers of the youngest generations, although a few scattered forms which are used by all speakers reflect the application of a general rule affecting word-initial /wk/ at an earlier stage in the history of the language.

The /w/ of the third person prefix is lost altogether in certain environments. Initial /w-wə/ regularly surfaces as o through the application of two rules, one by which /wə/ contracts to /o/ after a word-initial non-syllabic and another by which initial /w/ is deleted before /o/. Initial /w/ is also frequently deleted before a non-syllabic sonorant.

Because the treatment of word-initial non-syllabic sonorants varies so much according to the age of the speaker, it is not always easy to see what the grammatical systems of the different age groups have in common. Some discussion of the antecedents of the contemporary Passamaquoddy situation, as reflected in nineteenth and early twentieth century recordings, are discussed in the last part of this section. It seems likely that many of the alternations in question have become morphologized for the youngest Passamaquoddy speakers, but not enough data is available from young speakers to establish any conclusions in this area with certainty.

### 5.3.1 Devoicing of /m/

Since /m/, /n/, and /w/ are the only non-syllabic sonorants which occur word-initially in clusters, it is not necessary to mention these segments explicitly in our statement of Initial Devoicing. It is also unnecessary to mention explicitly that triggers of devoicing are always obstruents, since the only voiceless segments which occur in underlying forms are

obstruents. Initial Devoicing can therefore be given a preliminary formulation as follows.

(119) Initial Devoicing (preliminary)

$$\begin{array}{ccc}
 C & & C \\
 | & \longrightarrow & [-\text{voiced}] / \# \text{ \_\_\_\_\_\_ } | \\
 [-\text{sonorant}] & & [-\text{voiced}]
 \end{array}$$

For all but the youngest speakers, devoicing is optional in at least some contexts. In general, older speakers are more likely to retain m, n, and w, while younger speakers are more likely to apply devoicing. Application of the rule is most likely for all speakers where a potential target is initial in an utterance or follows a non-syllabic, while retention of a word-initial voiced sonorant in the environment for devoicing is most likely after a word ending in a vowel. I will suggest below that these effects on the applicability of the rule are readily explained if we revise (119) so that targets of the rule are required to be unsyllabified rather than word-initial. This restatement will make crucial use of the restrictions on the distribution of unsyllabified segments in derived forms in Passamaquoddy which were proposed in Chapter 4.

Voiceless m in the output of Initial Devoicing is sometimes retained in phonetic forms by speakers in their sixties or older. More often, however, these speakers replace /m/ with p. For younger speakers, this adjustment is obligatory. The rule which changes /m/ to p may be stated as follows.

$$(120) \begin{bmatrix} +\text{labial} \\ -\text{voiced} \end{bmatrix} \rightarrow [-\text{nasal}]$$

I assume that a [+stop, -nasal] segment, as /m/ will become through the application of (120), is automatically marked [-sonorant] by convention. Thus /m/ becomes p by (120).

Phonetic voiceless w is now only rarely heard in Passamaquoddy, and voiceless /n/ is consistently eliminated by all speakers. Both are replaced by h in surface forms. This change can plausibly be viewed as the deletion of all but the laryngeal features of either segment, but I will not attempt a formalization of this idea here.

Rules (119) and (120), taken together, produce alternations like those in (121).

- (121) a. mkw-éyo  
 ~ pkw-éyo  
 red-AI/II-(3)  
 'he, it is red'
- b. msáhk-éyo  
 ~ psáhk-éyo  
 sorry-AI-(3)  
 'he is sorry about something'

Only the oldest speakers (roughly, those over 60) use the m-initial alternants of such words when pronouncing them in isolation. Devoicing is apparently not obligatory for these speakers, even in cases of this kind, but it is primarily in such



isolated pronunciations that I have heard partially or fully devoiced [m] from these speakers.

For speakers in the age group from about 30 to 60, alternants with initial voiced m are possible when there is a preceding word which ends in a vowel. Such forms are common in this environment in the speech of those over 60. Thus forms like those in (122) are possible for speakers over 30, who would not generally use the m-initial alternants in (121), and are more likely than the latter forms even for speakers in the oldest age group.

- (122) a. <sup>é</sup>li mkw-<sup>é</sup>yi-k  
          thus red-II-3IN  
          'the way it is red'
- b. <sup>kí</sup>si <sup>msahk</sup>-<sup>é</sup>yo  
          past sorry-AI-(3)  
          'he was sorry about something'

Retention of stem-initial m is perhaps most likely when the preceding word in a preverb or prenoun, as in (122). But devoicing is possible in this position, just as it is at the beginning of a noun or verb complex. In (123), /m/ is devoiced after the preverb kisi 'past,' but retained after -atəli 'ongoing action.' The two examples were provided by the same speaker (D.F.).

- (123) a. k'isi pk-án-ot-sápan-ik  
 past choose-by.hand-UNSPEC/3(3)-DUBIT-33PROX  
 'they (an.) who had been picked out, chosen'
- b. ht-átali mk-án-a-l  
 3-ongoing choose-by.hand-DIR-3.OBV  
 'he is picking the other out'

The position following a preverb or prenoun is sharply distinct in this respect from word-internal position. There is no devoicing in word-internal clusters:

- (124) a. ámke  
 play-(3)  
 'he plays a game, runs for political office'
- b. hsám-kíhkwən  
 too-size-(3)  
 it is too big'
- c. náci-simsá-ne  
 go-collect.firewood.by.boat-11  
 'let's go out in the canoe and collect firewood'

The particle psí, psíw 'all, every' is sometimes pronounced msí, msíw by the oldest speakers.<sup>9</sup> Younger speakers seem always to use to the forms with p, except in the common phrase nít te msíw 'that's all,' which I have heard with m even from one speaker who is now in his early twenties. This exception aside, the replacement of /m/ by p in the environment for devoicing appears to be obligatory for speakers younger than about 30.

All of the clusters in which Initial Devoicing is applicable are historically derived from CVC or CVhC sequences, and most are synchronically derived through syncope. The deleted vowel may be /a/, /i/, or /ə/. Examples involving syncope of /a/ and /i/ will be discussed in 6.1. and 6.2. Examples involving the deletion of /ə/ after /m/ are given in (125)-(128).

- (125) a. mək-ən-a-l  
 (3)-choose-by.hand-DIR-3.OBV  
 'he picks the other out'
- b. pk-ən-a-t  
 choose-by.hand-DIR-3AN-(SUBJ)  
 'if he picks the other out'
- c. mək-ən-a-t  
 choose-by.hand-DIR-3AN-(PERF)  
 'when he picked the other out'

- (126) a. n-məs-ən-əke-nè-hk  
 1-get-by.hand-PASS-SUBORD-ASPECT  
 'ever since I got caught'
- b. n-kísi ps-ən-ke-nè-hk  
 1-past get-by.hand-PASS-SUBORD-ASPECT  
 'ever since I got caught'
- c. mès-ən-əki-yàn  
 get-by.hand-PASS-1-(PERF)  
 'when I got caught'

- (127) a. mətkwápi-m  
 (3)-bag-POSS  
 'his bag'  
 b. ptəkwàp  
 'bag'

It is clear from paradigms in which p does not alternate with m that /m/ must be underlying where the two segments do alternate. Examples like (128) exclude any general rule which would change /p/ to m in unsyncoated forms.

- (128) a. h-pəkwa'-hto-n  
 3-earn-TI-3IN  
 'he earns it'  
 b. óli pkwa'-hto-n man  
 (3)-good earn-TI-3IN money  
 'he earns good money'

Some occurrences of p in the output of Initial Devoicing have apparently been reanalyzed as underlying /p/ by some speakers. Thus some speakers have forms like (129) for 'fishhook' and its derivatives, while others have (130).

- (129) a. mkíhkən  
 ~ pkíhkən  
 'fishhook'  
 b. məkkihk n  
 (3)-fishhook  
 'his fishhook'

- (130) a. pkihkən  
           'fishhook'  
       b. h-pəkkihkən  
           3-fishhook  
           'his fishhook'

### 5.3.2 Devoicing of /n/

Devoicing of word-initial /n/ shows age-grading similar to that for the devoicing of /m/: retention of n where devoicing is possible is most common among the oldest speakers; devoicing appears to be obligatory for speakers under thirty. However, it appears that retention of n before an obstruent is possible in utterance-initial position for speakers in the middle age category who would not ordinarily pronounce m in this position.

At the beginning of an utterance, voiced n is optionally retained before an obstruent by speakers in their thirties or older. In the alternative pronunciations, where devoicing has applied, underlying /n/ is reflected by tenseness and aspiration of a following stop and by tenseness of a following s, without aspiration. These phonetically tense obstruents are distinct from utterance-initial plain stops and s, which are voiceless but lax before a vowel. Thus the tense initial consonants of the second alternants in (131) contrast with the lax initial segments of the corresponding forms in (132).

- (131) a. npíson  
 ~ [p<sup>h</sup>]íson  
 'medicine'
- b. nkámás-te  
 ~ [k<sup>h</sup>]ámás-te  
 easy-be.located-(3)  
 'it is easy to get at'
- c. nsáwát-əm  
 ~ [s]áwát-əm  
 careful-TI-(3)  
 'he is careful'
- (132) a. [b]ís-əkəní-ke  
 into-brush(?)-AI-(3)  
 'he walks into high grass, brush, etc.'
- b. [g]əmíwən  
 rain-(3)  
 'it rains'
- c. [z]áwe wtáme  
 often smoke-(3)  
 'he smokes often'

After a word which ends in a vowel, retention of voiced n before an obstruent is again optional for speakers over 30. There are two phonetic treatments, however, where devoicing has taken place. Underlying /n/ may be reflected in these cases by tensing/aspiration of the following obstruent, just as in utterance-initial position; but phonetic [h] (typically a voiceless continuation of the preceding vowel) is also be heard

in place of /n/ in this context. The obstruents which follow [h] in cases of this kind are tense but unaspirated, just like obstruents which follow /h/ in word-internal position:

- (133)             $\left. \begin{array}{l} \text{npíson.} \\ \text{[hp]íson.} \end{array} \right\}$   
           má te  
           not EMPH medicine  
           'There is no medicine.'

- (134) wǎlí nsawat-ǎm  
        ~ wǎlí [hs]awat-ǎm  
           good careful-TI-(3)  
           'he is very careful'

Note that the sequence /ihs/ is not replaced by ǎss in (134). Thus we must either restrict H-Deletion I (section 4.2.2) to word-internal environments or order it before the rule which derives [h] from devoiced /n/.

Since phonetic tenseness is characteristic of obstruents in hC clusters, it seems appropriate to suppose that the tense obstruents which result from devoicing in initial /nC/ are represented as clusters of the form hC at the point in derivations which is reflected in our transcriptions. The fact that phonetic [h] is a possible reflex of /n/ in examples like (133) and (134) offers confirmation for this analysis, which I have therefore adopted in transcribing initial tense obstruents in this work.

This hypothesis requires us to suppose that phonetic rules convert initial h-stop clusters into aspirated stops and delete initial h before s under appropriate conditions. We might suppose that the effect of aspiration results from the metathesis of h with the following consonant, since initial stop-h clusters are also realized as aspirated stops: khákə̀n [k<sup>h</sup>a'gɪn] 'door' (underlying /kə̀həkə̀n/; see 5.5). At least for some speakers, however, initial Ch is typically realized with heavier aspiration than initial hC, so I have chosen to maintain an orthographic distinction between these two classes of clusters in all environments.

Presumably there is phonetic overlap between initial h-stop and stop-h clusters for all speakers. The verb [k<sup>h</sup>]ápo 'he is blind' has two sets of forms, used by different speakers, probably as a result of this phonetic ambiguity:

- (135) a. níkhə̀p  
 (1)-blind  
 'I am blind'
- b. nékhapí-t  
 blind-3AN-(PERF)  
 'when he was blind'
- c. kákawí nkhapó-hpə̀n  
 nearly(?) blind-(3)-PRET  
 'he was more nearly blind'
- d. [k<sup>h</sup>]ápo = khápo  
 blind-(3)  
 'he is blind'



- (136) a. níhkàp  
 (1)-blind  
 'I am blind'
- b. néhkapi-t  
 blind-3AN-(PERF)  
 'when he was blind'
- c. [k<sup>h</sup>]ápo = hkápo  
 blind-(3)  
 'he is blind'

The forms in (135) presumably reflect underlying /nikhapi-/ 'blind', while those in (136) reflect /nihkapi-/. Both forms of the root contain syncoating /i/. In the case of (135d), we may suppose that initial /h/ is lost before /CC/ in the cluster /hkh/ which results from devoicing. In (136c), /h/ is deleted between two consonants in the cluster /nhk/ which results from syncope. Word initial /nk/ becomes hk. Both kh and hk may be realized as aspirated stops. We expect some difference in the degree of aspiration of this segment according to the analysis of the stem adopted by a particular speaker, but this effect cannot be confirmed at present.

When /n/ is devoiced in initial /nC/ after a word which ends in a non-syllabic segment, the resulting /h/ may be lost without a trace. This result is expected, since /h/ is consistently deleted word-internally in clusters of the form /ChC/ which arise in the course of derivations (see 6.4.1 for discussion). It also appears to be possible, however, for /h/ to be reflected by tenseness/aspiration of the following obstruent in these cases,

just as it is in initial position; although it may be that this type of pronunciation is excluded when the two words involved are truly pronounced in a connected fashion. Many of the phonetic details of forms which have undergone devoicing remain to be clearly established.

There is no trace of /h/ from underlying /n/ where a consonant cluster follows, as in (137). The following segment (s in almost all cases) will be tense in any event, since any obstruent is tense before another obstruent within a word.

(137) (n)skáwe-wí-ntow-ákən

perform.greeting.ceremony-DA-sing-NOM

'ceremonial greeting song'

Note the retention of n in the word-internal nt cluster. As in the case of /m/, devoicing of /n/ takes place only in word-initial clusters.

In almost all cases, the clusters in which n may be replaced by h appear to be synchronically derived through syncope. An example involving the deletion of /i/ was given in (135)-(136). Other cases of this kind will be discussed in 6.1. (I do not know of any words in which the deleted vowel is /a/.) More frequently, the deleted vowel is /ə/, as shown in (138)-(142). The underlying form of the stem is given first for each set of examples.

- (138) a. /nəpison/  
           'medicine'
- b. nəpíson  
           (3)-medicine  
           'his medicine'
- c. skícínəw-i npíson  
           Indian-PN medicine  
           'Indian medicine'
- d. hpíson  
           'medicine'
- (139) a. /nəpakət-əw-/  
           'lie to'
- b. nəpakət-ów-a-l  
           (3)-lie-TA-DIR-3.OBV  
           'he lies to the other'
- c. éli kisi npakət-à-sk  
           thus past lie-TA-3(3)/2-(PERF)  
           'the way he lied to you (sg.)'
- d. hpákət-əw-à-t  
           lie-TA-DIR-3AN-(SUBJ)  
           'if he lies to the other'
- e. népakət-əw-à-t  
           lie-TA-DIR-3AN-(PERF)  
           'when he lied to the other'

- (140) a. /nəkəmas-əpi-/  
 'be (physically) accessible'
- b. nəkə́mās-əpi-n  
 (3)-easy-sit-SUBORD  
 'he is accessible (Subordinative)'
- c. hkə́mās-əpo  
 easy-sit-(3)  
 'he is accessible'
- d. nəkə́mas-əpì-t  
 easy-sit-3AN-(PERF)  
 'when he was accessible'
- (141) a. /nəkwt-ól-əm-/  
 'travel alone by canoe; have one point  
 (in the traditional dice game)'
- b. k-nəkwt-ól-əm  
 2-one-canoe-AI  
 'you (sg.) canoe alone, have one point'
- c. hkwt-ól-əm  
 one-canoe-AI-(3)  
 'he canoes alone, has one point'
- d. nəkwt-ól-ə-k  
 one-canoe-AI-3AN  
 'he who canoes alone, has one point'

(142) a. /nəss-ol-əm-/

'have three points (in the traditional dice game)'

b. nəss-ól-əm

(1)-three-canoë

'I have three points'

c. ns-ól-əm

~ hs-ól-əm

three-canoë-AI-(3)

'he has three points'

d. nəss-ól-ə-k

three-canoë-AI-3AN

'he who has three points'

In all of the examples that I have found in which /n/ becomes h before /s/, the /s/ is either geminate, as in (142), or the first member of a cluster, as in (137). (Forms like nəssawát-əm-ən ((3)-careful-TI-3IN) 'he is careful with it, about it' show that ns ~ hs is derived from /nəss/ in (131c) and (134).) Since s is tense in clusters in any case, it might be argued that the tenseness of initial [s] from /ns/ is due to its position in an underlying cluster, rather than to the phonetic effects of h, as I have suggested above.

It should be noted, however, that an underlying geminate stop has the same phonetic realization as an underlying single stop in utterance-initial position after a site where /n/ has undergone devoicing. In either case, the remaining segment is short, tense, and aspirated. Thus the phonetic segment which results from syncope, devoicing, and the replacement of /n/ by h

in /nəkkek-/ 'all day' in (143b) is indistinguishable from the phonetic segment which results from the application of the same rules in underlying /nəkəmas-/ 'easy' in (140b). Both are [k<sup>h</sup>].

- (143) a. nəkkek-əlòhk  
 (1)-all.day-work-(AI)  
 'I work all day'
- b. hkék-əlòhk-e  
 all.day-work-AI-(3)  
 'he works all day'
- c. nékkek-əlòhk-e-t  
 all.day-work-AI-3AN  
 'he who works all day'

Now it is quite generally the case that a geminate consonant is shortened after another consonant. For example, the underlined p in (144a) is short (and lax), even though it is derived from an underlying geminate, as a comparison with (144b) reveals.

- (144) a. kp-ásəka-h-m-òn  
 close-lock-TI-TI-2  
 'lock (sg.) it!'
- b. h-kəpp-asəká-h-m- n  
 3-close-lock-TI-TI-3IN  
 'he locks it'

It seems reasonable to attribute the shortening of /kk/ in (143b) to the same process. But /ss/ is also shortened after another consonant (although s is tense in this position). Thus the /ss/

of /k<sub>ə</sub>ssə-/ 'in' is shortened in (145\b), where it follows /k/ in the output of syncope.

- (145) a. h-k<sub>ə</sub>ssé-hl-a-l  
3-in-TA-DIR-3.OBV  
'he lets the other in'
- b. k<sub>ə</sub>ssé-hl-a-t  
in-TA-DIR-3AN-(SUBJ)  
'if he lets the other in'

Thus the phonetic tenseness of utterance-initial [s] from /ns/ cannot be attributed to its derivation from underlying /ss/, but must result from the presence of another preceding consonant at the point in derivations at which the phonetic rule which determines the phonetic tenseness of s in clusters applies. This consonant could either be the underlying /n/ itself or the h which is derived from it. Since h seems like the most likely trigger for the aspiration of stops after sites of devoicing, I assume that it is also h which accounts for the tensing that we find in the corresponding cases with s.

### 5.3.3 Phonetics of the first person prefix

A class of apparent exceptions to the devoicing of initial /n/ results from the application of a voicing rule which is triggered only by the /n/ of the first person prefix n(t)-. These seeming exceptions are easily accommodated by ordering the special voicing rule for the prefix before Initial Devoicing.

This result is surprising, however, since apart from the first person forms in question voicing is not distinctive in Passamaquoddy.

After the /n/ of /n(t)-/ FIRST PERSON (the only prefix which contains this segment), any obstruent is voiced before a vowel. Some examples are given in (146). Note that the /t/ of /nt-/, the pre-vocalic form of the prefix, is always in a position to undergo voicing. This /t/ is therefore always phonetically [d], as in (146f).

- (146) a. n-[b]óhtáya-m  
1-bottle-POSS  
'my bottle'
- b. n-[d]ák-əm-a  
1-hit-TA-DIR  
'I hit him'
- c. n-[ʃ]áls-əm  
1-grasshopper-POSS  
'my grasshopper'
- d. n-[g]ápəcəl  
1-hoarse  
'I am hoarse'
- e. n-[z]íw  
1-relative  
'my relative; my buddy'
- f. n[d]-ákəm  
1-snowshoe  
'my snowshoe'



Obstruents other than s and c are voiced between vowels by most Passamaquoddy speakers, but the voicing induced by the first person prefix is noticeably stronger, affects s and c as well as the other obstruents, and is found in the speech of all members of the community. Except in careful speech, the n of the prefix is often dropped, especially by younger speakers, leaving the voicing which it triggers as the only mark of its presence: [ziw] 'my buddy.' The position following the /n/ of the prefix is the only environment in Passamaquoddy in which voicing is not predictable on the basis of segmental conditions alone. In all other clusters in which a non-syllabic sonorant is followed by an obstruent, the obstruent is voiceless and tense. (The same complex of facts is described for Maliseet by Teeter (1973:196).

Since the voicing rule which it triggers eliminates the conditions for devoicing, the /n/ of the prefix is never devoiced. Neither [h] nor any of the phonetic effects which I have attributed to h are heard in forms with the first person prefix.<sup>10</sup>

We can easily account for the fact that the /n/ of n(t)- is not subject to devoicing by ordering the voicing rule which this prefix triggers before Initial Devoicing. This leaves us with a simple picture of Initial Devoicing, but adds another dimension to the peculiarity of the voicing process illustrated in (146). This rule not only represents an intrusion of morphological conditioning into the system of rules which determine the distribution of an otherwise non-distinctive feature, but also appears to be a rule of phonetic character which must be ordered

among the phonological rules of the language, those which produce alternations between phonemes.

#### 5.3.4 Devoicing of /w/

Voiceless w in the output of Initial Devoicing may be maintained in surface forms even in utterance-initial position in the variety of Maliseet described in Teeter (1973:196), but this segment virtually always undergoes further reduction in the speech of my Passamaquoddy consultants. In fact I have recorded phonetic [w] only once, although the speaker (A.H.), a woman now in her forties, repeated the form upon request, again pronouncing [w] with no hesitation:

- (147) n-kísi [w]tám-hə̀ti-p n  
1-past smoke-PL-11  
'we (pl.) smoked'

Apart from this example, I have recorded only h as the result of the devoicing of /w/, with phonetic reflexes like those of h from /n/.

Even among the oldest Passamaquoddy speakers that I have worked with, the devoicing of /w/ is obligatory in utterance-initial position. After a vowel, w alternates with h before an obstruent for speakers over 30.

- (148) a. mécimí te wtáme  
 always EMPH smoke-(3)  
 'he always smokes'  
 = b. mécimí te htáme

The alternants with w are only common in the speech of those over 60, and speakers younger than 30 apparently never use them. Again there is some indication, from pairs of examples like the following, that retention of the voiced segment is most likely at the boundary between a preverb or prenoun and the word that it modifies (both examples from D.F., a man in his sixties).

- (149) a. má nt-áhcawi wtáma-w.  
 not 1-must smoke-NEG  
 'I do not need to smoke.'  
 b. nt-áhcawi má htáma-w.  
 1-must not smoke-NEG  
 'I must not smoke.'

As expected, devoicing does not take place in word-internal /wk/:

- (150) sákamá-w-ka-n  
 chief-DA-dance-UNSPEC  
 'a governor's ball is held'

At the beginning of an utterance or after a pause, and optionally in other positions, h from /w/ is reflected only by tenseness and aspiration of a following stop and by tenseness of a following s.

(151) [t<sup>h</sup>]əme

smoke-(3)

'he smokes'

(152) a. h-káti wsiki-y-a-l

3-future suffer-TA-DIR-3.OBV

'he makes the other suffer;

he punishes the other'

b. [s]íki-y-à-t

suffer-TA-DIR-3AN-(SUBJ)

'if he makes the other suffer;

if he punishes the other'

As in comparable cases where /n/ undergoes devoicing, there is no phonetic reflex of devoiced /w/ before a cluster, and at least optionally no reflex after a word ending in a nonsyllabic (although utterance-initial treatment of the second word in cases of the latter type may also be possible).

Again the environments in which devoicing takes place are the historical result of vowel deletion. Reanalysis has clearly taken place in some initials, but there are still a number of morphemes which alternate in ways which we can explain by setting up underlying /w C/. (I know of no cases in which /a/ or /i/ is deleted after a word-initial /w/.) This sequence general does not occur in any surface alternant, however. After the personal prefixes, where /ə/ is protected from syncope, /wə/ is usually contracted to o. In Changed Conjunct forms of verbs, initial /wə/ is replaced by /we/.

The result is an alternation, in verbs, of w or h in unprefixes, Unchanged forms with o in prefixed forms and we in Changed forms. The o which results from contraction surfaces in initial position in third person forms as the result of a rule which deletes initial /w/ before /o/. Several stems which alternate according to this pattern are shown in (153)-(156). I give first the underlying form of the stem, then forms showing deletion, contraction, and Change.

(153) a. /wətəma-/  
 'smoke'

b. kisi wtəme  
 past smoke-(3)  
 'he smoked'

c. n-ótə̀m  
 1-smoke  
 'I smoke'

d. wətəma-t  
 smoke-3AN  
 'he who smokes'

- (154) a. /wəsiki-y-/  
 'cause to suffer; punish'
- b. nésipi                      wśiki-y-óc-ik  
 additionally suffer-TA-3PASS-33PROX  
 'they who were inadvertently made to suffer'
- c. ósiki-y-a-1  
 (3)-suffer-TA-DIR-3.OBV  
 'he makes the other suffer;  
 he punishes the other'
- d. wésiki-y-a-t  
 suffer-TA-DIR-3AN-(PERF)  
 'when he punished the other'

- (155) a. /wəcipilkwe-/  
 'have epilepsy'
- b. hcípilkwe  
 epileptic-(3)  
 'he has epilepsy'
- c. n-ócipilkw  
 1-epilectic  
 'I have epilepsy'
- d. wécipilkwe-t  
 epileptic-3AN  
 'he who has epilepsy'

- (156) a. /wət-əs-əm-/  
 'cut a piece from'
- b. ht-əs-ə-k  
 3-from-cut-TI-3AN  
 'if he cuts a piece from it'
- c. ót-s-əm-ən  
 (3)-from-cut-TI-3IN  
 'he cuts a piece from it'
- d. wét-s-ə-k  
 from-cut-TI-3AN  
 'he is cutting a piece from it;  
 where he cut it off'

Before a consonant cluster, the alternation is usually one of zero with o and we:

- (157) a. /wəskəw-eyi-/  
 'spend time (in a place)'
- b. sków-éyo  
 spend.time-AI-(3)  
 'he often spends time there'
- c. n-óskow-èy  
 1-spend.time-AI  
 'I often spend time there'
- d. wésków-eyi-t  
 spend.time-AI-3AN-(PERF)  
 'when he used to spend time there'

In nouns we find an alternation between w, h, or zero in unprefixated forms and o in prefixed forms:

- (158) a. /wətapakən/  
'vehicle'  
b. htápákən  
'car, sled, etc.'  
c. n-ótapákən  
1-vehicle  
'my car, sled, etc.'

- (159) a. /wəskítape-/  
'man'  
b. skítàp  
'man'  
c. óskítapé-m-əwa-l  
(3)-man-POSS-33PROX-3.OBV  
'their man'

Especially in cases where a consonant cluster follows a devoicing site, where underlying /wə/ is not phonetically recoverable, these alternations are not always consistently maintained. Thus one may hear kci wskícìn 'old Indian' (with kci 'big, great') but éskícínəw-í-yek (Indian-AI-11) 'we (du. exc.) who are Indians,' both derivatives of skícìn 'Indian.' The first of these forms suggests an underlying stem beginning with /wə/, while the second points instead to underlying initial /ə/. Some discussion of the attested patterns of variation will be found in 6.2 and in 9.4.



Although the personal prefixes usually take the forms /nt-/, /kt-/, and /wt-/ before vowels, they appear without /t/ before surface o in forms like the (c) examples in (153)-(159). The reason, of course, is that o in these forms is derived from underlying /wə/. The contraction rule which converts /wə/ to o in cases of this kind may be stated as follows, provided that it is ordered after V-Epenthesis, so that underlying floating schwas will have received V-slots in the initial syllables of prefixed forms by the time the rule is applied.

(160) Contraction

C	C	V		C	V
			-->		
	w	ə		o	

Given this formulation of Contraction, the rule will only be applicable to /wə/ in word-initial syllables. There are a variety of word-internal contractions which resemble the process exemplified in (153)-(159), but I will not attempt to pin down the relationships among these alternations here.

The third person prefix /w/ is deleted before /o/ in the output of Contraction. This operation may be formally stated as (161). (If /kw/ is analyzed as a sequence of /k/ and /w/ on the segmental tier, the only [+round] non-syllabic in Passamaquoddy is /w/ and the only [+round] vowel is /o/.)

(161) WO-Reduction

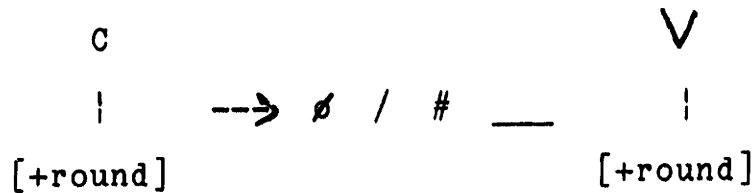

Although /w/ is the third person prefix in all forms which undergo this reduction, (161) can be stated as a general rule, since no Passamaquoddy words begin with wo.

The independence of WO-Reduction and Contraction is confirmed by the inflection of dependent nouns. In nouns of this type, which occur only in possessed forms, the personal prefixes appear without /t/ before vowel-initial stems. The forms in (162) are typical.

- (162) a. n-íkwəss  
1-mother  
'my mother'
- b. k-íkwəss  
2-mother  
'your (sg.) mother'
- c. w-íkwəss-əl  
3-mother-3.OBV  
'his mother'

When the noun stem begins with /o/, as in (163) and (164), the /w/ of the third person prefix is deleted:

- (163) a. n-óhkəməss  
 1-grandmother  
 'my grandmother'
- b. óhkəməss-əl  
 (3)-grandmother-3.OBV  
 'his grandmother'
- (164) a. n-óhsím-is  
 1-younger.sibling-DIM  
 'my younger sibling'
- b. óhsím-ís-əl  
 (3)-younger.sibling-DIM-3.OBV  
 'his younger sibling'

Since o does not alternate in the paradigms of these nouns, and since the absence of /t/ in the prefixes follows here from independent considerations, there is no reason to derive o in these case from underlying /w /.

Both Contraction and WO-Reduction are applicable in paradigms in which the environment for devoicing does not arise. Both rule apply, for example, in the derivation of (165b), where the third person prefix is added before the AI+O stem /wəlamət-əm-/ 'believe.' But /ə/ is not deleted before the sonorant /l/ in (165a), so that underlying /wəl/ appears as such on the surface in this form.

- (165) a. wə́lamsət-ə̀-k  
 believe-AI-3AN-(SUBJ)  
 'if he believes'
- b. ólamsət-əm-ən  
 (3)-believe-AI-PEG  
 'he believes in it'
- c. wə́lamsət-ə̀-k  
 believe-AI-3AN  
 'he who believes'

While WO-Reduction is obligatory, Contraction is often optional, especially when a sonorant consonant follows:

- (166) a. ólí-nəm-ən  
 ~ wəlí-nəm-ən  
 (3)-good-see-3IN  
 'he likes the way it looks'
- b. ón-tém-a-l  
 ~ wən-tém-a-l  
 (3)-distract-strike-TA-DIR-3.OBV  
 'he bothers the other (while the other is talking)'

Examples of optional contraction where an obstruent follows are less common. The uncontracted form in (167b) is unusual in that it provides direct attestation of the /wəC/ sequence which underlies a cluster in which /w/ undergoes Initial Devoicing.

- (167) a. htáhákən  
           paddle  
       b. óthák n  
        ~ wáthák n  
           (3)-paddle  
           'his paddle'

The underlying form of the stem in these examples is probably /wətəhəkən/, with loss of the first /ə/ in unprefixed forms and loss of the second in prefixed forms, as dictated by alternating stressability. (See 5.5 for syncope before /h/.)

### 5.3.5 Phonetics of the third person prefix

In section 4.2.4 I noted that the /w/ of the third person prefix /w(t)-/ is sometimes retained on the surface before a non-syllabic where there is a preceding word which ends in a vowel. Several examples of the retention of /w/ in verb forms were given there. To these may be added the following cases of surface w in noun inflection:



- (170) a. ...ónak-éssi-n,      nà      [h]t-ǎl-ewésto-n.  
 (3)-rise-move-SUBORD in.turn 3-thus-speak-SUBORD  
 '...he rises, and in his turn speaks.'
- b. ...ónak-éssi-n,      [t<sup>h</sup>]-ǎl-ewésto-n...  
 (3)-rise-move-SUBORD 3-thus-speak-SUBORD  
 '...he rises, speaks...'

The prefix /w-/ may also be added to stems which begin with a non-syllabic sonorant. Initial Devoicing is not applicable in this environment, so no phonetic reflexes of /h/ are heard in cases of this kind. Instead the prefix is usually simply deleted. For the oldest speakers, this deletion, like the devoicing of /w/ before obstruents, is optional after a word which ends in a vowel, as in (171), but obligatory after a non-syllabic or after a pause.

- (171) mécimí te      (w)-mǎs-ǎn-ǎm-ǎn  
 always EMPH 3-get-by.hand-TI-3IN  
 'he always gets it'

Speakers in the intermediate age group, however, seem to find it much less acceptable to retain /w/ before a non-syllabic sonorant than before an obstruent.

Since Initial Devoicing will not account for the deletion of initial /w/ in forms like mǎs-ǎn-ǎm-ǎn 'he gets it,' another rule is required for these cases. A preliminary formulation is given in (172). Although it is not necessary to mention the third person prefix explicitly in this rule, there is in fact no other source for clusters of /w/ and a non-syllabic sonorant.

(172) W-Deletion (preliminary)

C		C
	---> ∅ / # _____	
w		[+sonorant]

I will suggest below that this rule, like Initial Devoicing, should be reformulated so that its target is an unsyllabified C.

Teeter has noted a special treatment of /k/ after the third person prefix in Maliseet, "giving as a phonetic result a slightly aspirated labiovelar quite distinct from that of a stem beginning with [the unit phoneme] kw" (1973:196). I have occasionally heard similar pronunciations from some of my Passamaquoddy consultants. A few examples are given in (173)-(176), together with forms which show the same stems with basic stem-initial k.

- (173) a. nít te w-kísáci-n  
then EMPH 3-ready-SUBORD  
'then he is ready'
- b. h-kwísáci-n  
3-ready-SUBORD  
'he is ready (Subordinative)'
- (174) a. tàn h-kéhs-əlóhk-a-n?  
how 3-X.much-work-AI-SUBORD  
'How much did he work?'
- = b. tàn h-kwéhs-əlóhk-a-n?



- (175) a. h-kʰsəm-ə́n-əm-ən  
 ʒ-push-by.hand-TI-ʒIN  
 'he pushes it'  
 = b. h-kwʰsəm-ə́n-əm-ən

- (176) a. h-kʰspíson  
 ʒ-belt  
 'his belt'  
 = b. h-kwʰspíson

Teeter suggested that the labiovelars that we find in comparable Maliseet examples might be derived via metathesis of /wk/ to /kw/. But the aspiration of the resulting phonetic segments which he reports, and which is also typical of the Passamaquoddy forms, suggests instead that /w/ remains in initial position in these cases, where it undergoes devoicing, ultimately becoming h. This is my reason for transcribing initial h in all of the examples in (173)-(176). That this conclusion is correct is confirmed by the fact that w may appear on the surface to the left of a stem-initial labiovelar which is derived from underlying /k/, provided that the context is one in which the devoicing of /w/ is not obligatory:

- (177) a. má te w-kwísi-htó'-w-ən  
 not EMPH ʒ-past-TI-NEG-ʒIN  
 'he did not make it'  
 cf. b. má te n-kísi-htó'-w-ən  
 not EMPH 1-past-TI-NEG-ʒIN  
 'I did not make it'

Of course, if no metathesis rule is involved the derivation of the labiovelars in examples like (173)-(177), then there must be a rounding rule instead. We can give this process a preliminary formulation as shown in (178). Once again the rule must be restricted in some manner so that it is applicable only to initial /wk/, since medial /wk/ is not affected in forms like sak ma-w-ka (chief-DA-dance-(3)) 'he does a (tribal) governor's dance.'

(178) K-Rounding (preliminary)

C		C		C	
	-->	/ \	/ #		—
k		k w		w	

We might seek to explicate this process in terms of autosegmental spreading of the feature [round], but I will not pursue this question here. This rule, like Initial Devoicing and W-Deletion, will be reformulated below in terms of syllabification.

K-Rounding shows even steeper age grading than Initial Devoicing and W-Deletion. Only a few of my oldest consultants (P.D., S.G., D.F.) appear to use forms showing the effects of K-Rounding in spontaneous speech. My principal consultant in the intermediate age group (A.H.) finds forms of this kind quite acceptable but describes them as "old language." I have not heard her use them in ordinary conversation. One of my younger consultants was surprised to hear that some speakers used third person forms with kw for k and commented that she had never heard them. (Her statement is especially interesting, since this young

woman was then living within a few hundred yards of the speakers from whom I heard the most examples of this type.) The rapid decline in the frequency of application of K-Rounding which these comments suggest may be connected with the fact that even those speakers who use the rounded forms most often seem to avoid them in careful speech.

Despite the marginal status of K-Rounding in contemporary Passamaquoddy, it is clear that this rule was once frequently applied. Two stem allomorphies which are found in the speech of all age groups clearly result from reanalysis of earlier surface forms derived by K-Rounding.

The stem of the noun kát 'leg (including the foot)' shows up with k in possessed forms for non-third person possessors, but forms with third person possessors are usually made on a stem /-kwat/, even by speakers who never otherwise use kw for k after the third person prefix:

- (179) a. n-kát-ʔl  
           1-leg-33IN  
           'my legs'
- b. h-kwát  
           3-leg  
           'his legs'
- c. h-kwáti-hkó<sup>l</sup>wa-k  
           3-leg-PL-33-LOC  
           'on their legs'

The shapes in which the stem of the verb 'be angry' shows up in prefixed and Changed forms suggest an underlying form

/wəhkayɪ-/ , but unprefixed forms are always made on a stem /hkwayɪ-/ , again apparently by all speakers.

- (180) a. n-óhkàɪ  
1-angry  
'I am angry'
- b. wéhkayɪ-t  
angry-3AN-(PERF)  
'when he was angry'
- c. hkwáyo  
angry-(3)  
'he is angry'

In the case of this verb, the earlier use of unprefixed forms with initial wk is attested. J.D. Prince (1921) published edited versions of texts which had been written out about 1911 by Lewis Mitchell of Pleasant Point, ME, in an orthography of his own devising. For the most part, Prince did not reproduce Mitchell's original spelling, choosing instead to rewrite the texts in his own orthography. While many forms are undoubtedly clearer as a result of Prince's efforts, certain errors and obscurities appear to have been introduced as a result of his assumptions about initial sonorants. I will return to this matter below. Despite these problems, however, two forms of the verb 'be angry' seem to point clearly to wk where one now hears only kw:<sup>11</sup>

- (181) a. "w'kayoltowuk"  
 = wkáy-oltó-w- k  
 angry-PL-3-33PROX  
 'they (pl.) are angry' (p. 58)
- b. "tan etutci w'kâyt"  
 = tàn étóci wkáyi-t  
 how at.that.point angry-3AN  
 'when he is angry' (p. 72)

The application of K-Rounding and Initial Devoicing to these forms from Prince would give forms of the type found in the contemporary language. Thus it seems reasonable to suppose that the current unprefixated stem /hkwayi-/ results from the reanalysis of an original surface alternant of the stem as an underlying stem allomorph. The allomorphic relationship between /hkwayi-/ and the other stems of this verb has been maintained while the frequency of application of K-Rounding has undergone a steep decline. The possessed stem /-kwat/ 'leg' presumably has a similar history, starting out as a surface variant of -kat after the third person prefix.

It may be worth noting that 'be angry' would have been a particularly likely candidate for reanalysis. The underlying form /wəhkayɪ-/ might appear to have been easily justified in the early years of this century. But in fact I know of no other stem for which a clear case can be made for setting up an underlying form containing /əhC/. (Such sequences are excluded in surface forms except in a few suffixes.) Moreover, /wəhkayɪ-/ would apparently have been the only stem in which syncope produced a

word-initial cluster which was subject to K-Rounding. In the contemporary language, /w/ is the third person prefix in all occurrences of word-initial /wk/ which are potential inputs to this rule. The elimination of the unprefixed forms of hkwáyo as cases of K-Rounding thus produced a state of affairs in which the rule was triggered only by a single morpheme. Or, to put the matter the other way around, taking K-Rounding to be a rule which was specifically applicable to the third person prefix may have entailed the reanalysis of /wəhkayi-/.

### 5.3.6 The role of syllabification

We have now identified three rules for which a word-initial non-syllabic sonorant before another non-syllabic serves either as a target or as a trigger: Initial Devoicing, W-Deletion, and K-Rounding. The first two of these rules are applied more or less often (by middle-aged and older speakers) depending on a variety of environmental factors: application of the rules is favored in utterance-initial position and after a word ending in a non-syllabic, and non-application is most likely after a word ending in a vowel. This complex of facts has a straightforward explanation if the rules are reformulated in terms of syllable structure.

I argued in and 4.5.4 that the output of the word-level phonological rules of Passamaquoddy is subject to a requirement of full syllabification, the Unsyllabified Consonant Filter. Through the device of extrametricality, exceptions are permitted

in just one environment: word-initial position. This special status of initial position is the key to the explanation that I will propose for the shared properties of Initial Devoicing, W-Deletion, and K-Rounding.

Let us first consider some representative words beginning with /w/ as they appear in the input to Initial Devoicing, W-Deletion, and K-Rounding: /wtəme/ > htəme 'he smokes,' /wməsənəmən/ > məsənəm n 'he gets it,' and /wkisacin/ > hkwisacin 'he is ready (Subordinative).' Let us further restrict our attention for the moment to cases in which one of these words begins an utterance or follows a pause. Under these circumstances, the initial /w/ of each of these words must be unsyllabified, since the only complex onsets created by the Passamaquoddy syllabification rules are clusters of the form sC. Our three examples will therefore be represented as shown in (182).

(182) a.

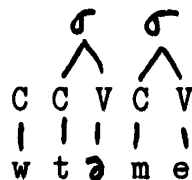

b.

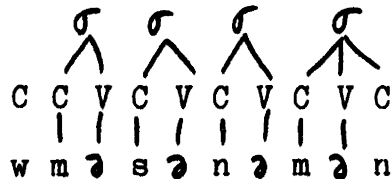

c.

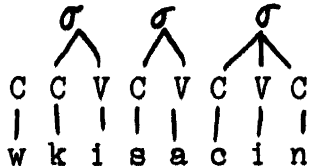

Suppose, then, that we reformulate the rules that we have been considering so that they refer not to word-initial non-syllabic sonorants, but instead to extrasyllabic sonorants. The suggested restatements are given in (183).

(183) a. Initial Devoicing

$$\begin{array}{ccc}
 C' & & C \\
 | & \longrightarrow & | \\
 [+sonorant] & [-voiced] / \_\_ & [-voiced]
 \end{array}$$

b. W-Deletion

$$\begin{array}{ccc}
 C' & & C \\
 | & \longrightarrow & | \\
 w & \phi / \_\_ & [+sonorant]
 \end{array}$$

c. K-Rounding

$$\begin{array}{cccc}
 C & & C & C' \\
 | & \longrightarrow & / \ \ \backslash / \ | & \_\_ \\
 k & & k & w \quad w
 \end{array}$$

Rules (183a-c) will correctly pick out initial /w/ in each of the words in (182), since the appropriate segment is extrasyllabic in each case. In fact, (183a-c) will be precisely equivalent to their prototypes which specify word-initial non-syllabic sonorants, provided that they are ordered after all of the word-level rules of the language, given that unsyllabified segments occur only in initial position in the output of the word-level rules. But Initial Devoicing, W-Deletion, and K-Rounding must be



phrase-level rules in any case: regardless of how we formalize them, these rules affect only segments which are unsyllabifiable at the word level and will therefore be designated as extrametrical and invisible to word-level rules.

Let us consider specifically the rule of Initial Devoicing, restricting our attention for the moment to speakers in the middle and upper age categories. (I will return to the problems presented by the speech of the youngest group below.) We noted above that /w/ is consistently devoiced in utterance-initial position or where it follows a non-syllabic. This fact suggests that Initial Devoicing is an obligatory rule. But if the rule is obligatory, how can we account for the fact that voiced /w/ is optionally retained after a vowel-final word? Once we reformulate devoicing as in (183a), we can give a simple explanation for this fact. We need only suppose that a /w/ which has not been incorporated into a syllable may be syllabified with a preceding vowel across a word boundary. Once a word-initial /w/ is syllabified in this way, it will no longer be a possible target of Initial Devoicing, since the rule is applicable only to unsyllabified segments.

As an example, consider the phrase mécimí te wtəme ~ mécimí te htəme 'he always smokes.' The suggested process of syllabification would have the following effect:

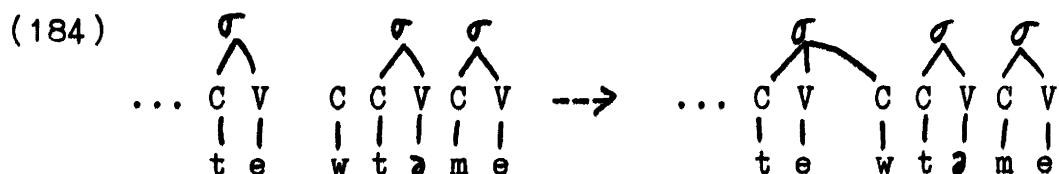

If this operation is carried out before the application of Initial Devoicing, /wtáme/ will no longer contain an unsyllabified /w/ to undergo this rule.

Moreover, we have already postulated a rule to which this change in syllabification can be attributed. Rule (185), the second of the "basic syllabification rules" of 4.5.4, syllabifies a C-slot with an immediately preceding V. I will refer to this process as Leftward Syllabification. If this rule is permitted to apply across word boundaries as well as within words, it will automatically carry out the change shown in (184).

(185) Leftward Syllabification

(part of basic syllabification)

$$\begin{array}{ccc} \sigma & & \sigma \\ | & \dashrightarrow & / \backslash \\ V & C & V & C \end{array}$$

Since we have assumed that the rule which forms onsets of CVC syllables takes precedence over (185), the latter will, in fact, only be applicable to a word-initial C-slot which precedes another non-syllabic.<sup>12</sup>

Now we have assumed that the basic syllabification rules are obligatory in word-internal contexts and that they may be applied at any point in derivations at which their structural descriptions are met. Extending these assumptions to phrase-level applications of Leftward Syllabification, however, leads to incorrect predictions about the contexts in which Initial Devoicing is applicable. By permitting the syllabification of /w/ across word boundaries in cases like (184), we correctly

predict that the application of Initial Devoicing may be avoided here. But if Leftward Syllabification is obligatory in this context, it will always bleed devoicing in cases of this kind. If syllabification may take place at any point in derivations, then we will not be able to escape from this problem by invoking rule ordering. Thus we are left with no way to derive mécimí te htáme, the alternate form of mécimí te wtáme in which /w/ is devoiced and changed to h.

Suppose, then, that we adopt the following convention concerning the application of rules of syllabification:

(186) The application of rules of syllabification is obligatory within a word, but optional across a word boundary.

This convention has several consequences for the interaction of Leftward Syllabification with Initial Devoicing, all of which appear to be correct.

First, the application of Leftward Syllabification before Initial Devoicing makes it possible to retain voiced /w/ after a vowel, as we have already noted. But if Leftward Syllabification is optional in phrasal contexts, then the change in syllabification shown in (184) need not be carried out. When this change is not made, word-initial /w/ will remain unsyllabified in a phrase like /memcimi te wtáme/. Initial Devoicing will then be applicable, and /w/ will be changed to h. Thus we correctly predict the optionality of the devoicing of /w/ in post-vocalic contexts. But if Leftward Syllabification may be applied at any point in a derivation, then it will also be

applicable to the output of Initial Devoicing. Thus Leftward Syllabification may make the change shown in (187) instead of that shown in (184).

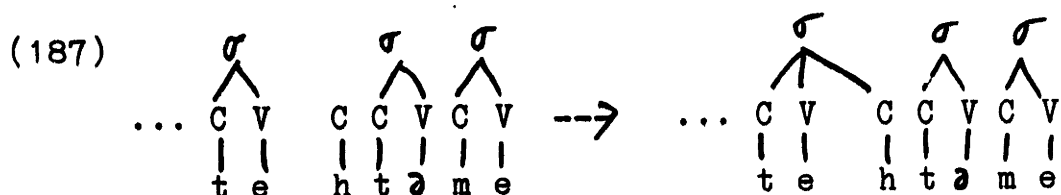

The resulting structure contains a syllable-final h. Thus we expect that the class of phonetic realizations permitted for VhC where h results from Initial Devoicing will include those permitted for VhC in word-internal contexts (a voiceless continuation of the vowel, glottalization superimposed on this vowel, etc.). This again appears to be correct.<sup>13</sup> However, since Leftward Syllabification will again be optional here, the change in syllabification shown in (187) need not be made. Thus we predict that it should also be possible to give word-initial hC the same kind of phonetic treatment after a vowel it obligatorily receives in utterance-initial position. This prediction, too, appears to be correct: word-initial h can apparently be realized in any context only by tensing of a following s, tensing and aspiration of a following p, t, c, k, or kw.

The interaction of Initial Devoicing with Leftward Syllabification accounts well for the surface reflexes of initial /w/ before obstruents, and for their distribution, on the assumption that Initial Devoicing is obligatory but Leftward Syllabification optional (in the relevant domains). Indeed, the fact that the retention of /w/ is relatively favored after a

preverb or prenoun can plausibly be attributed to a greater willingness to apply Leftward Syllabification across a word boundary in these syntactically close collocations.

The situation is more complicated, however, when we take cases involving initial /m/ or /n/ into account. We can easily explain why the devoicing of /m/ and /n/ is optional after a vowel-final word. This effect follows directly from the proposals that we have made for /w/. But for Passamaquoddy speakers in the oldest age group, both /m/ and /n/ may be retained, without devoicing, even in utterance-initial position. Speakers in the middle age category do not retain voiced /m/ in this position, but may retain voiced /n/. Yet we have assumed that Initial Devoicing is an obligatory rule.

Here again, however, a simple explanation is available, once we consider the role of syllabification in devoicing. For when voiced /m/ or /n/ is retained at the beginning of an utterance, the phonetic realization of either of these segments is a syllabic nasal. But a syllabic nasal is, of course, not an unsyllabified segment. If Initial Devoicing is applicable only to unsyllabified segments, then all that we need to do to prevent the devoicing of utterance-initial /m/ or /n/ is to order Initial Devoicing after the rule which makes these segments syllabic.

Within the framework of CV phonology, a syllabic segment is one which is associated with a V-slot. Thus the utterance-initial alternants of mkwéyo 'he, it is red' and npíson 'medicine' with syllabic initial m and n must be represented as shown in (188a). To derive these representations from those shown in (188b), which result from syncope, we need a rule which

changes a C position to a V position. The required rule is stated in (189). (Recall that a rule which introduces a V position on the CV tier automatically introduces a syllable node as well, by convention.)

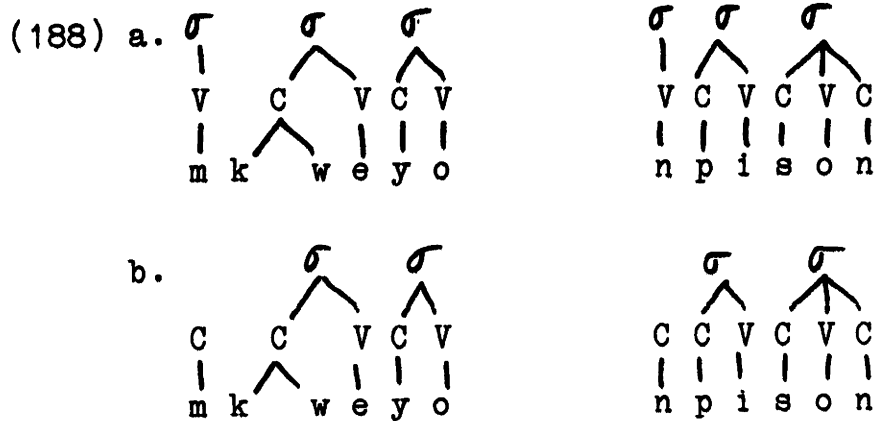

(189) Syllabic Nasal Formation (oldest age group)

$$C' \rightarrow V / \text{ \_\_\_\_\_\_ } \\ | \\ [+nasal]$$

This general rule of Syllabic Nasal Formation will produce the right results for the oldest speakers, provided that it is optional and precedes Initial Devoicing. Where the rule is applied, its output will be a syllabic m or n which will not undergo devoicing. Where the rule is not applied, /m/ and /n/ obligatorily undergo devoicing. For elderly speakers, the rule which changes voiceless /m/ to p is optional, so these speakers will occasionally have [m] in surface phonetic representations. Even for these speakers, however, voiceless /n/ is always replaced by h.

For speakers in the middle age category, rule (189) is too general. These speakers, only /n/ may be exempted from Initial Devoicing in utterance-initial position. For these speakers, then, we can postulate a more specific rule of Syllabic Nasal Formation:

(190) Syllabic Nasal Formation (middle age group)

$$C' \text{ ---} \rightarrow V / \text{ \_\_\_\_\_\_ }$$

$$|$$

$$\left[ \begin{array}{l} +nasal \\ +coronal \end{array} \right]$$

Note that Syllabic Nasal Formation, in either formulation, will derive a syllabic nasal from the /n/ of the first person prefix, as well as from /n/ before an obstruent. This is, in fact, a correct result. Speakers in the middle and upper age groups frequently pronounce the n of the first person prefix as a syllabic segment in those styles of speech in which this consonant is not eliminated through the kind of reduction of initial clusters which was discussed in 4.5.3 and 4.5.4. Since the youngest speakers tend to apply this type of cluster reduction much of the time, it is not clear whether a rule like (190) can be motivated on the basis of the speech of this group. In any case, no such rule appears to be applied by the youngest speakers in positions in which it would bleed Initial Devoicing.

We can now see that it is possible to account for the variation among Passamaquoddy speakers in the details of the application of Initial Devoicing without building any of the

relevant constraints into to rule itself. The oldest speakers, as we have seen, permit both Leftward Syllabification and a general rule of Syllabic Nasal Formation to precede Initial Devoicing, therefore preventing certain applications of the devoicing rule. Speakers in the middle age category also allow Leftward Syllabification to precede Initial Devoicing, but they apparently prefer to apply these rules in the opposite order, since they are more likely than their elders to apply devoicing where Leftward Syllabification is applicable. These speakers apparently also employ a more restricted rule of Syllabic Nasal Formation, with the result that they permit n but not m to escape devoicing in utterance-initial position.

Although the rule system that I have proposed permits a simple account for the seemingly quite complex facts involving the devoicing of word-initial sonorants, it does not seem particularly natural. We noted in 5.3.3 that the voicing rule which is triggered by the /n/ of the first person prefix must precede Initial Devoicing, even though it determines the value of an otherwise non-distinctive feature. Non-distinctive differences in syllabification are adjusted by Syllabic Nasal Formation, yet this rule too must apparently precede Initial Devoicing, even though the latter determines alternations between phonemically distinct segments like m and p. On the other hand, the fact that the treatment of initial non-syllabic sonorants has clearly been undergoing rapid change suggests that the phonological situation represented by the oldest contemporary speakers of Passamaquoddy is indeed marked. I will return to the



question of the historical development of this system in the following subsection.

The youngest Passamaquoddy speakers apparently apply Initial Devoicing as frequently as possible, no longer permitting any rules to bleed the devoicing process. (The phrase nít te msíw 'that is all,' in which voiced m has apparently been retained by at least one young speaker, might be regarded as a phonetic idiom, with lexically specified syllabification.) These speakers may have abandoned Syllabic Nasal Formation altogether. It seems likely, however, that some version of Leftward Syllabification is still in use among speakers of this group. For example, k appears to have the phonetic length associated with syllable-final position in expressions like táma kt-áli? (somewhere 2-thus-(go)) 'Where are you (sg.) going?' for speakers of all ages. Perhaps, then, these speakers have turned the preference for early application of Initial Devoicing that we noted among speakers of the middle age group into an absolute requirement, so that Leftward Syllabification is not allowed by these young speakers to apply freely at any point in derivations in the phrase-level phonology. It is also possible, however, that some or all of the alternations produced by Initial Devoicing have been reinterpreted as non-phonological allomorphy by the youngest speakers.

Let us return now to the two other rules discussed above which involve word-initial extrasyllabic consonants: W-Deletion and K-Rounding. For the oldest speakers, W-Deletion shows the same seeming optionality after a vowel-final word as Initial Devoicing does. If we apply the same explanation in both cases,

we will say that W-Deletion is obligatory but that optional Leftward Syllabification may either precede or follow W-Deletion for these speakers. For speakers in the middle age group, however, there seems to be an even stronger preference for the application of W-Deletion before Leftward Syllabification than there is for relatively early application of Initial Devoicing. Perhaps this preference for the application of W-Deletion is related in some fashion to the fact that the only clusters of w and a sonorant consonant at the level represented in our transcriptions are those in which W-Deletion is applicable. However this may be, Leftward Syllabification never bleeds W-Deletion for speakers in the youngest age category, just as it never bleeds Initial Devoicing for these speakers.

The forms which motivate K-Rounding are heard only from the oldest speakers. The effects of this rule appear to be optional in all environments. The simplest way to account for this situation is to assume that K-Rounding itself is optional. Leftward Syllabification, of course, will bleed K-Rounding, but this situation presents no problem if syllabification across word boundaries is optional. Speakers in the intermediate age group appear to have passive knowledge of K-Rounding, but do not usually use forms derived by this rule. The rule has simply been dropped from the grammar by the youngest speakers.

The rule system that I have proposed for the word-initial phonological effects that we have looked at may be summarized as follows. In addition to the rule of Leftward Syllabification, which applies optionally across word boundaries and has special ordering properties, we have seen evidence for the following

phonological rules, with some variation in obligatoriness or the details of the formal statements of a few of them according to the age of the speaker:

- (191) a. Contraction (160)
- b. WO-Reduction (161)
- c. voicing after the /n/ of /n(t)-/ FIRST PERSON  
(not formalized)
- d. Syllabic Nasal Formation (189) or (190)
- e. Initial Devoicing (183a)
- f. W-Deletion (183b)
- g. K-Rounding (183c)
- h.  $\underset{\circ}{m} \rightarrow p$  (120)
- i.  $\underset{\circ}{n}, \underset{\circ}{w} \rightarrow h$  (not formalized)

For all speakers, Contraction must precede WO-Reduction, since Contraction creates /wo/ sequences which undergo reduction. Contraction must also precede Syllabic Nasal Formation, in either formulation, since the first person prefix n- is never pronounced as a syllabic nasal before o derived by Contraction. Contraction is sporadically optional (especially for young speakers), while WO-Reduction is obligatory.

For all speakers, the voicing rule triggered by the first person prefix must precede Initial Devoicing, since the prefix is never devoiced. For the speakers who have it (all but the

youngest) Syllabic Nasal Formation also precedes and bleeds Initial Devoicing, although only /n/ becomes syllabic in the speech of the intermediate age group.

For speakers over 60, Leftward Syllabification may either precede or follow Initial Devoicing and W-Deletion. Speakers in the 30-60 age group favor the application of Initial Devoicing before Leftward Syllabification and strongly favor the application of W-Deletion before Leftward Syllabification. For speakers younger than about 30, it appears that both Initial Devoicing and W-Deletion must consistently be applied before Leftward Syllabification. Despite the complex age-graded differences in the frequency of application of Initial Devoicing and W-Deletion in different environments, both rules can be given the same formal statement as obligatory processes for all speakers.

For the oldest speakers, K-Rounding is an optional rule which may be applied when /w/ in initial /wk/ does not undergo Leftward Syllabification. Speakers in the intermediate age group know the rule, but generally do not apply it. The rounding rule has been dropped from the grammar by the youngest speakers, although isolated irregularities in certain stems reflecting the former widespread application of the rule remain in use among all speakers.

### 5.3.7 Looking back and looking ahead

Prior to the change of devoiced m to p and of devoiced n and w to h, Initial Devoicing must have been a phonetic rule in the strict sense. The age-graded variation in the surface distribution of devoicing that I have described above appears to reflect a gradual shift in the point of application of the devoicing rule from later to earlier points in phonological derivations. Projecting this trend backward, we can imagine a time in the history of Passamaquoddy when Initial Devoicing always followed the application of Leftward Syllabification. Non-syllabic sonorants would then have undergone devoicing just when they could not be syllabified at the phrase level.

A number of nineteenth-century recordings of Passamaquoddy suggest, however, that the precursor of Syllabic Nasal Formation was not only more frequently applied than the contemporary rule but was also more general: it apparently derived o from /w/ as well as deriving syllabic nasals. Then as now the only extrasyllabic sonorants that could arise in phonological derivations were /m/, /n/, and /w/. For the nineteenth-century language, then, we can formulate a general rule of Syllabic Sonorant Formation:

(192) Syllabic Sonorant Formation (no longer in use)

$$C' \rightarrow V / \quad \underline{\quad}$$

|

[+sonorant]

This rule evidently preceded and bled Initial Devoicing.

A word list compiled in 1854 by Henry Prince contains a number of items which are of particular interest in this connection.<sup>14</sup> Prince noted that w was voiceless in "Whs-kee-tâp'" wskítap 'man' (contemporary skítap), commenting explicitly that "the first syl. is whispered" (1854, no. 4). Forms like "Oo-sku'-nis" oskánis 'bone' (no. 47; contemporary skánis) and "Co-ta-ha'-gun" otáhákən 'paddle' (no. 82; contemporary htáhákən) show the vocalization of /w/, preventing the application of Initial Devoicing. For 'claw' (no. 213), he gives both "Oo-kât'" and "Sheep-sis qat-see-z." The former must be okát 'his leg,' with vocalization of the third person prefix /w-/, while the latter must be sípsis kwátsis or the like, 'a bird's little leg,' showing K-Rounding and the subsequent devoicing and loss of the prefix. It is tempting to regard these last examples as evidence that Syllabic Sonorant Formation bled K-Rounding as well as Initial Devoicing in 1854, but of course we cannot exclude the possibility that forms went unrecorded in which both K-Rounding and the vocalization of /w/ took place.<sup>15</sup>

The dialect spoken by Lewis Mitchell, whose life spanned the turn of the century, apparently preserved the optional rule of Syllabic Sonorant Formation in its general form. Thus some occurrences of initial "o" in Mitchell's texts represented /w/ while others represented /o/. In cases of the first kind, replacing o by w would have given an alternate form of the same word. This fact apparently misled J.D. Prince into rewriting as "w" some occurrences of "o" which represented the result of applying Contraction and WO-Reduction to underlying /w-wə/. The

effects of this decision can be seen by comparing the text of his 1897 edition of "The Passamaquoddy Wampum Record" with that of the version which he included with Mitchell's later work in his 1921 text collection. The earlier version apparently adhered more closely to Mitchell's spelling. The following examples are chosen from a single page of each text (Prince 1897:486, 1921:10).

1897	1921	interpretation	contemporary
-----			
a. w'skittapyik	w'skitapyik	wskítápiyik	skítápiyik
'men (prox.)'			
b. oskittapi	oskitapi	oskítapì	skítapì
'men (obv.)'			
c. oskittapem	oskitap'm	óskitápem	óskitápem
'his men (obv.)'			
d. omaweman	omaweman	omáwéman	máwéman
'he calls the others together (Subordinative)'			
e. omoosketunia	w'musketunya	omóskehtóniya	móskehtóniya
'they take it/them (in.) out (Subordinative)'			
f. oskmaknesum	w'skmaknes'm	ósəmákənəssəm	ósəmákənəssəm
'his warriors (obv.)'			

Here (a) appears to show surface w without vocalization, while (b), (d), (e) reflect the vocalization of /w/ and (c) and (f) reflect Contraction and WO-Reduction. J.D. Prince's analysis of (e) was correct, but his analysis of (f) was wrong, leading to an incorrect revision in his 1921 text. (It is clear that the revision was not based on hearing the word again, since the "k" which must represent a misreading of some vowel letter remains unchanged.) Similar errors were introduced in the spelling of words like óhsimísəl 'his younger sibling,' with o from underlying /wo/, which Prince (1921:72) gives as "w'simis'l" 'his younger brother' (see note 10).

In nineteenth and early twentieth-century Passamaquoddy, every word which was potentially subject to Initial Devoicing must have had three alternate forms, one the result of applying Syllabic Sonorant Formation, one derived by Leftward Syllabification without devoicing, and one in which Initial Devoicing was applied. Initial Devoicing would also have been involved in numerous paradigmatic alternations.

With the restriction and eventual elimination of Syllabic Sonorant Formation and the shift in the point in derivations at which Initial Devoicing is applied, so that it usually precedes Leftward Syllabification, there has been a change in the kind of evidence for Initial Devoicing which is available either to the linguist or to the language learner. The only evidence for this rule in the speech of the youngest Passamaquoddy speakers comes from paradigmatic alternations.

But several types of paradigm leveling have also been taking place during the last century, and at an increasing rate. I



noted above in 5.3.1 that some speakers have reanalyzed underlying /m/ as /p/ in stems where m and p had been in paradigmatic alternation. We also saw evidence in 5.3.3 that the three forms assumed by the stem of hkwáyo 'he is angry' are no longer treated as phonologically related by any speakers. Other cases involve more extreme reanalyses. For example, some speakers (e.g. A.H.) have taken surface forms like hpákət-əw-à-t (lie-TA-DIR-3AN-(SUBJ)) 'if he lies to the other,' reflecting the application of Initial Devoicing to underlying /nəpakət-əw-/, as the basis for a new alternative underlying stem /hpakət-əw/. The result is prefixed and Changed forms made on an invariant stem: hpákət-ów-a-l alongside nəpakət-ów-a-l ((3)-lie-TA-DIR-3.OBV) 'he lies to the other,' hpákət-ow-à-t alongside nəpakət-ow-à-t (lie-TA-DIR-3AN-(PERF)) 'when he lied to the other.' The same speaker accepts méhkvéyo and mákwkwéyo as alternatives to pkvéyo 'he, it is red,' forms which reflect the Changed stem and a version of the prefixed stem of this verb in unhistorical contexts. (These forms are rejected by my older consultants.) Novel forms like these are undoubtedly most frequently used by the youngest speakers, but are not limited to them.

Such radical reanalyses are hardly surprising, since the changes which have affected the output of Initial Devoicing have made the rule highly opaque. As such reanalyses proliferate, it seems inevitable that Initial Devoicing will be lost as a phonological rule, leaving behind scattered sets of allomorphic relationships. This point may already have been reached by some of the youngest speakers. The status of underlying /wəC/ in forms which undergo Initial Devoicing seems especially shaky,

since this sequence generally does not appear as such in any surface alternant of a stem. The underlying form of the third person prefix /w(t)-/ is also quite difficult to motivate on the basis of the forms which are found in the speech of the youngest age group. I will take up the question of the underlying forms of the prefixes in the following section.

#### 5.4 Underlying and derived clusters

It is one of the principal claims of the CV theory of stressability that the effect of alternating stressability results from the application of the same rule which accounts for the effects of clusters on underlyingly unstressable vowels, namely V-Epenthesis. For this claim to have any meaning, of course, it must be the case that underlying forms do in fact contain sequences of non-syllabics which affect the status of a following /ə/. If we could show instead that all surface CC sequences after which underlyingly unstressable/ə/ becomes stressable are derived by syncope from underlying /C C/, there would be no need to recognize any "cluster effects" on stressability. This is essentially the position taken by Sherwood (1983b:32) in his analysis of syncope in Maliseet. If this view of the conditions which determine stressability could be maintained, there would be little to motivate an account of the phonology of Passamaquoddy which attempts to relate the distribution of stressable and unstressable vowels to the principles which govern syllabification.

Four arguments are presented below which demonstrate that cluster effects on stressability are real and cannot be explained

by deriving the clusters in question from underlying /CəC/. Given the reality of such cluster effects, it becomes unnecessary to postulate underlying forms for the personal prefixes n(t)-, k(t)-, and w(t)- ~ h(t)- which contain underlying schwas. In fact the best synchronic account of the phonology of these prefixes will derive them from underlying /n(t)-/, /k(t)-/, and /w(t)-/.<sup>16</sup>

#### 5.4.1 Arguments for underlying clusters

In 4.2.4 we saw that an underlyingly unstressable /ə/ becomes stressable when it follows a morpheme which ends on the surface in a sequence of non-syllabics, provided that the first segment in the cluster is not h. The morphemes which produce this effect include ones like pisk- 'dark,' amalh- 'fancy,' and pask- 'break' which always appear in the same shape in surface forms. For example, the /ə/ of /-ən-/ 'by hand' is treated as stressable in h-pásk-ə́n-əm-ən (3-break-by.hand-TI-3IN) 'he breaks it with his hand,' even though this vowel must be underlyingly unstressable, since the next following /ə/ is stressable by alternating stressability in h-péhk-ən-əm-ən (3-completely-by.hand-TI-3IN) 'he takes it all.'

Additional examples involving syncope were given in 5.2.2., where we saw that syncoating /ə/ is retained on the surface when it follows aps- 'small,' sakh- 'into view,' or pask- 'break' -- again morphemes which are invariant in shape. Thus the initial /ə/ of /-əkil-/ 'be a size' is retained on the surface in

áps-ə́kil (small-size-(3)) 'he is small' but eliminated by Schwa Deletion I in kín-kil (large-size-(3)) 'he is big.'

The special status of hl, as opposed to clusters of h and an obstruent, is also reflected both in stress assignment and in syncope. Thus the /ə/ of the reflexive final /-əsi-/ is retained on the surface and stressed after hl in ác-ehl-ə́so (change-TA-REFLEX-(3)) 'he changes himself'; but this vowel must be underlyingly unstressable, since it undergoes syncope in forms like kál-so (hide-REFLEX-(3)) 'he hides.'

Now we can certainly account for the effects of elements like pask- and aps- on the status of a following /ə/ if we postulate underlying forms for these morphemes in which their surface clusters are represented by underlying /CəC/. Suppose, for example, that the underlying form of aps- is /apəs-/, with unstressable /ə/. Then the underlying form of áps-ə́kil is /apəs-ə́kil-w/. But now the /ə/ of /-kil-/ will be stressable by alternating stressability, since it is in second position in a series of schwas which will fall under this principle in any of the accounts that we have considered.

The problem with this approach is that there is no independent motivation for the underlying form /apəs-/. Because the a of aps- is inherently stressable, the /ə/ of putative underlying /apəs-/ will always undergo syncope. And indeed the root aps- is invariant in form. In the case of morphemes containing hl, the situation is even worse. While alternations between pəs and ps are common in Passamaquoddy, there are no surface alternations between həl and hl. To reduce the effects of hl on a following /ə/ to alternating stressability, then, we

must derive all relevant occurrences of hl by syncope, even though syncope between /h/ and /l/ never results in any surface alternations.

Consider next the ways in which syncope may take place in underlying /CəCəC/. Depending on the larger context, either the first or the second /ə/ in such a sequence may be deleted -- but not both. For example, the first /ə/ in underlying /ləsəkʷ/ is deleted in the derivation of tál-sákwe 'he is checking traps' from /ətəl-əsəkwe-w/ (ongoing-check.traps-3). The second /ə/ in /ləsəkʷ/ is deleted in the derivation of étəl-éskwe-t 'he is checking traps (Conjunct)' from /etəl-əsəkwe-t/ (ongoing-check.traps-3AN). But no form like \*təl-skwe or \*etəl-skwe-t is possible, since the derivation of such a form would require the deletion of both schwas in underlying /ləsəkʷ/. The reason, of course, is that alternating stressability guarantees that the second /ə/ in /CəCəC/ will always be stressable if the first is not.<sup>17</sup>

We see, then, that triconsonantal clusters cannot be derived by syncope from /CəCəC/. Yet such clusters are in fact quite common, many of them do not alternate, and they have the same effect as clusters of two consonants on the status of a following / /. We have seen, for example, that the underlyingly unstressable /ə/ /-ələn-/ 'rain' becomes stressable after the non-alternating cluster psk of -apsk- 'round' in étót-apsk-éla-k (extreme-round-rain-3IN) 'it is raining very big drops.' The same effect can be seen in kín-apsk-əso (large-round-AI-(3)) 'he is fat,' where the underlying unstressable /ə/ of the AI final /-əsi-/ does not undergo syncope because it becomes stressable

after /-apsk-/. (Clearly, of course, -apsk- cannot be derived from /-apsək-/. It is precisely the fact that there are no clusters like /ps/ after which /ə/ may remain unstressable that we are trying to explain.)

Since unstressable /ə/ regularly becomes stressable when it is the last underlying vowel of a word, word-final CC cannot be derived from /CəC/ in words which do not end in an underlying final vowel. For example, final ck in póktéwick 'liquor' cannot represent underlying /cək/, since this word is not pronounced with the final rising intonation which is characteristic of words which have undergone Final Vowel Deletion. But underlyingly unstressable /ə/ becomes stressable after this cluster in forms like h-póktéwick-ə́m-əwa (3-liquor-POSS-33PROX) 'their liquor.' (Compare ht-ə́tóhk-əm-əl 3-deer-POSS-3.OBV) 'his deer,' where the /ə/ of the possessive suffix /-əm-/ remains unstressable.)

There are also medial clusters which affect stressability but cannot be derived from /C C/ because they do not alternate as the conditions on syncope would require. To see this, consider first the forms of /nəsət-əm-/ TI 'understand' given in (193).

- (193) a. nə́st-ə̀m-ən  
 (3)-understand-TI-3IN  
 'he understands it'
- b. hsə́t-ə̀-k  
 understand-TI-3IN-(SUBJ)  
 'if he understands it'
- c. nə́st-ə̀-k  
 understand-TI-3AN-(PERF)  
 'when he understood it'

Here we have another case in which either the first or the second /ə/ in underlying /CəCəC/ may undergo syncope. In (193a), the first /ə/ of the stem is stressable because the third person prefix is used. The second /ə/ of the stem therefore remains unstressable and undergoes syncope. In the unprefix form (193b), the first /ə/ of the stem is unstressable instead, so it is deleted. Initial Devoicing gives hs for /ns/ in the output of syncope. The second /ə/ of the stem is retained, since it is stressable by alternating stressability. In (193c), the first /ə/ of the stem is replaced by the stressable vowel /e/ as a result of Initial Change, so it is again the second vowel of the stem which is deleted.

The pattern of alternations that we see in (193) contrasts with that shown in (194). Here the non-alternating sequence sk appears in place of st ~ sət.

- (194) a. m<sup>́</sup>sk-<sup>́</sup>m-<sup>́</sup>n  
 (3)-find-TI-3IN  
 'he finds it'
- b. psk-<sup>̀</sup>-k  
 find-TI-3AN-(SUBJ)  
 'if he finds it'
- c. m<sup>́</sup>esk-<sup>̀</sup>-k  
 find-TI-3AN-(PERF)  
 'when he found it'

If the stem of m<sup>́</sup>sk-<sup>́</sup>m-<sup>́</sup>n were underlying /m<sup>́</sup>s<sup>́</sup>k-<sup>́</sup>m-/, we would expect to find \*ps<sup>́</sup>k-<sup>̀</sup>-k for (194b), since the morphological structure of this form is exactly parallel to that of (193b). The fact that we do not shows clearly that the stem of m<sup>́</sup>sk-<sup>́</sup>m-<sup>́</sup>n must instead be /m<sup>́</sup>sk-<sup>́</sup>m-/, with underlying /sk/. But note that the /<sup>́</sup>/ of the TI element /-<sup>́</sup>m/ is treated as stressable here, even though this vowel is underlyingly unstressable, as forms like h-p<sup>́</sup>ask-<sup>́</sup>n-<sup>́</sup>m-<sup>́</sup>n 'he breaks it with his hand' attest. This treatment of the /<sup>́</sup>/ of /-<sup>́</sup>m-/ can only be due to the preceding cluster /sk/.

#### 5.4.2 The underlying forms of the prefixes

I have frequently noted in preceding sections that /<sup>́</sup>/ is always treated as stressable in the first syllable of a stem after one of the personal prefixes. The question that I would now like to address is whether this fact should be attributed to alternating stressability or to cluster effects. That is, are



the prefixes underlyingly /nə(t)-/, /kə(t)-/, and /wə(t)-/ or /n(t)-/, /k(t)-/ and /w(t)-/? I will argue here that the latter position is correct.

A third analysis is possible, since there is evidence for a rule of epenthesis in Passamaquoddy which inserts /ə/ between non-syllabics at morpheme boundaries: we could suppose that the underlying forms of the prefixes do not contain /ə/, but that the initial non-syllabic in a prefix triggers epenthesis. (This is in fact the analysis adopted by Sherwood (1983b:34).) I will not discuss this proposal in detail, since it appears to be open to the same objections as an account which posits underlying /ə/ in the prefixes. We will see in Chapter 7 that epenthesis must in any case be formulated as a morphologically governed rule. The restriction of epenthesis to contexts created by suffixation therefore seems unremarkable.

The effects of the prefixes on the location of stressable and unstressable positions are reflected by stress assignment in the forms in (195) and by syncope in those in (196).

(195) a. əpó

sit-(3)

'he sits'

b. kt-ə́pi-n

2-sit-SUBORD

'you (sg.) sit (Subordinative)'

- (196) a. kpácale  
hoarse-(3)  
'he is hoarse'
- b. n-kápəcal  
1-hoarse  
'I am hoarse'

Either hypothesis concerning the underlying forms of the prefixes is consistent with this data. If kt- is underlying /kət-/ in (195b), then the /ə/ of /əpi-/ is stressable in this form because it is the second /ə/ in underlying /kət-əpi-n/. If kt- is underlying /kt-/ instead, then the /ə/ of /pi-/ is stressable in this case because it follows a cluster in underlying /kt-əpi-n/. Similarly, if n- is underlying /n -/ in (196b), then the first /ə/ of /kəpəcale-/ is stressable here because it is the second /ə/ in underlying /nə-kəpəcale/. If, on the other hand, n- is underlying /n-/, then the first /ə/ of /kəpəcale-/ is stressable in (196b) because it follows a cluster in underlying /n-kəpəcale/. In both (195b) and (196b), underlying /ə/ in the prefix would be followed by an obstruent, so it would be deleted by Schwa Deletion I.

Not all of the data from prefixed forms is similarly neutral, however. To begin with, the prefixes surface without ə not only in environments where Schwa Deletion I is applicable, but everywhere. In particular, the surface forms n-, k-, and w-  $\sim$   $\emptyset$  are found before non-syllabic sonorants, but this is not an environment in which any independently motivated rule of syncope is applicable. Examples are given on (197).

(197) a. n-míhtakws

1-father

'my father'

b. k-wícohké-m-a

2-help-TA-DIR

'you (sg.) help him'

c. má te (w)-nán-əw-á-wi-yil

not EMPH 3-know-TA-DIR-NEG-3.OBV

'he does not know the other'

That these words begin with true clusters, not phonetic clusters which result from the phonetic deletion of unstressable ə, is confirmed by the fact that the k of the second person prefix is phonetically tense in forms like (197b). Word-initial k is lax before a vowel, but tense before a non-syllabic.

Occasionally one hears a phonetic ə between the first person prefix and a following m when a form like (197a) or a comparable verb form like n-más-ən-əm-ən-əl (1-get-by.hand-TI-3IN-33IN) 'I get them (in.)' is given a particularly explicit pronunciation. It seems best, however, to handle such cases by means of a late rule which inserts phonetic schwa, since I have also recorded [nəm] with syllabic [n̩] in such cases. Syllabic [n̩] in these forms presumably reflects the application of Syllabic Nasal Formation, which is not otherwise applicable in word-initial nəm, whether or not the ə is treated as stressable.

To derive forms like those in (197), given /nə(t)-/, /kə(t)-/, and /wə(t)-/ as the underlying forms of the prefixes, we will have to postulate a rule which deletes /ə/ in these

morphemes before sonorants as well as obstruents -- and which applies nowhere else. (Sherwood (1983b:34) proposes just such a rule for Maliseet.) In fact we must insure that this rule deletes /ə/ in all occurrences of the prefixes.

To do this, we will have to mark the prefixes as exceptions to the rule which makes the first /ə/ stressable in word-initial /((C)ə [+sonorant]ə /, Initial Syllable Epenthesis in the CV theory, even though this rule is otherwise completely exceptionless. Regular application of Initial Syllable Epenthesis or its equivalent to underlying /nə-məs-ən-əm-əl/ would give \*nəmsənəmənəl, not the form nməsənəmənəl 'I get them (in.)' that we actually find. Similarly, we would expect \*wənsətəmən for nəstəmən 'he understands it' and \*wəmskəmən for məskəmən 'he finds it.' Again this problem is entirely an artefact of the decision to analyze the prefixes as underlying /n:(t)-/, /kə(t)-/ and /wə(t)-/.

To sum up: We do not need schwas in the prefixes to account for their effects on stressability. We can only set up underlying /ə/ in these morphemes at the cost of adding an extra rule of syncope and exempting the prefixes from an otherwise exceptionless generalization. Moreover, these special provisions effectively secure treatment for the prefixes as if no underlying /ə/ were present. On these grounds, it clearly seems preferable to derive the prefixes from underlying /n(t)-/, /k(t)-/ and /w(t)-/.

While these arguments appear to me to be quite strong, there is a further set of facts which might be cited in support of the claim that the underlying form of the third person prefix is

/w (t)-/. The data in question concern the inflection of verbs whose stems contain the third person prefix.

Two types of denominal verbs are formed from possessed themes of nouns, partially inflected forms which consist of a personal prefix, the noun stem, and the possessive suffix (if the noun in question is one with which this suffix is used). In one formation, the AI final /-i-/ is suffixed to the noun theme to derive a verb of possession. In the second type, the AI final /-ne-/ ('die' when used in primary derivation) is suffixed to body-part terms to form verbs with the sense 'have an ache in or a medical problem associated with (the body part named in the stem).'<sup>18</sup>

Some examples of the two types are given in (198) and (199). Note that no prefix is supplied in any of these forms by the verbal morphology, since the third person prefix is not used with AI verbs in the Independent Indicative mode. The prefixes appear without /t/ before vowels in forms like (199a,b) because these verbs are based on dependent nouns.

(198) a. nícan-ì-w  
(3)-child-AI-3  
'he has a child'

b. maní-m-ì-w  
(3)-money-POSS-3  
'he has money'

c. ht-ówhem-ì-w  
3-pet-AI-3  
'he has a pet'

- (199) a. w-ípití-ne  
 3-tooth-ache-(3)  
 'he has a toothache'
- b. w-ániyakáni-ne  
 3-head-ache-(3)  
 'he has a headache'
- c. h-cáɫ kəsse-wí-ne  
 3-ear-DA-ache-(3)  
 'he has an earache'

Compare the possessed nouns in (200).

- (200) a. nícán-əl  
 (3)-child-3.OBV  
 'his child'
- b. máni-m  
 (3)-money-POSS  
 'his money'
- c. ht-ówhém-əl  
 3-pet-3.OBV  
 'his pet'
- d. w-ípit  
 3-tooth  
 'his tooth'
- e. w-ániyakən  
 3-head  
 'his head'

f. h-cálekəss

ʒ-ear

'his ear'

In the case of the verbs of possession, derivation is typically from the third person possessed theme. The third person prefix is usually not overt, of course, in cases like (198a,b), where it is followed by a non-syllabic sonorant. Speakers who permit Leftward Syllabification to bleed W-Deletion may pronounce the w of the prefix in such forms, however, in an appropriate environment:

(201) hsámi w-nícan-ì-w

too ʒ-child-AI-ʒ

'he has too many children'

First and second person forms of the prefixing modes are made by adding the appropriate prefix before the third person prefix in the stem. The second occurrence of the prefix then takes the forms -o(t)-, as shown in (202a,b). In (202c), 'have a pet' is inflected as a transitivized AI (AI+O) verb. Although the third person prefix is not used with AI Independent Indicative forms, it typically does appear in AI+O forms of this mode with third person subjects. Thus the underlying form of (202c) contains two occurrences of this prefix. The combination of the two prefixes surfaces as ot- as a result of the application of Contraction and WO-Reduction.

- (202) a. n-ó-nicàn  
 1-3-child-(AI)  
 'I have a child'
- b. k-ó-mání-m-í-pa  
 2-3-money-POSS-AI-22  
 'you (du.) have money'
- c. ót-ówhem-í-n-l  
 (3)-3-pet-AI-PEG-3.OBV  
 'he has the other as a pet'

In the favored pattern of inflection for body-part verbs, the third person prefix in the stem is replaced by the first or second person prefix where a prefix is called for by the verbal morphology:<sup>19</sup>

- (203) a. n-ípiti-n  
 1-tooth-ache  
 'I have a toothache'
- b. k-íniyakóni-né-pa  
 2-head-ache-22  
 'you (du.) have headaches'

Inflection of body-part verbs on the pattern of verbs of possession gives marginal results. Thus (204a) is preferred to (204b).



- (204) a. n-cálakásse-wì-n  
 1-ear-ache-DA-ache  
 'I have an earache'
- b. ?n-ó-cálakásse-wì-n  
 1-3-ear-DA-ache  
 'I have an earache'

Both verbs of possession and body-part verbs have Changed forms in which the third person prefix in the stem takes the form we-, except that the prefix does not become we- where it is immediately followed by the initial vowel of a dependent noun stem. If the first vowel of the stem is a, however, it may be replaced by e in Changed forms. Examples are given in (205) and (206).

- (205) a. wé-nicán-i-t  
 3-child-AI-3AN  
 'he who has a child'
- b. skát wé-maní-m-i-hti-h-kw  
 not 3-money-POSS-AI-33PROX-NEG-3-(PERF)  
 'when they (du.) do not have money'
- c. wét-owhém-i-t  
 3-pet-AI-3AN  
 'he who has a pet'

- (206) a. neke w-ípíti-ni-yàn  
 then 3-tooth-ache-2-(PERF)  
 'when you (sg.) had a toothache'
- b. w-éniyáka ni-ni-yàn  
 3-head-ache-1-(PERF)  
 'when I had a headache'
- c. wé-cálakássé-wi-ni-yàn  
 3-ear-DA-ache-1-(PERF)  
 'when I had an earache'

The overt expression of Initial Change is optional in body-part verbs, so the forms in (207) are equivalent to those in (206b,c). We will see in 9.1 that blocking or optionality of the expression of Change is characteristic of a variety of types of denominal verbs.

- (207) a. w-əniyáka ni-ni-yàn  
 3-head-ache-1-(PERF)  
 'when I had a headache'
- b. h-cálakássé-wi-ni-yàn  
 3-ear-DA-ache-1-(PERF)  
 'when I had an earache'

Both in verbs of possession and in body-part verbs, the third person prefix which forms part of the verb stem shows a surface alternation of w- (or one of its phonological transforms) with -o- and wé-. This pattern of alternation is the same as the pattern which is characteristic of stems beginning with /wə/ in underlying forms, as we saw in 5.3.4. (Compare, for example, the

paradigm of /wət-əs-əm-/ 'cut a piece from' given above in (156), where /wət-/ 'from' appears as ht- alternating with -ot- and wet-.) Thus the observed alternations in the form of the third-person prefix can be accounted for by independently needed rules if the prefix has the underlying shape /wə(t)-/.

The upshot of this discussion is that different criteria for the choice of an underlying form for the third person prefix lead us to different conclusions. I would like to suggest, however, that the evidence from denominal verbs is not in fact as strong as it at first might appear.

We have already seen evidence (in 5.3.5) that the alternation of initial h with -o- and we- in the stem of the verb hkwayo 'he is angry' is no longer phonologically determined. Other examples of patterns of alternation which resemble those of stems in initial /wə/ but which now appear to represent morphologically governed allomorphy will be discussed in 9.1. A morphological account of the forms in which the third person prefix appears in verbs of possession and in body part verbs would therefore not be unprecedented.

The full range of variants of the prefix in verbs of these types cannot be handled in purely phonological terms in any case. Where the base of the verb is a dependent noun in which the prefixes appear without /t/ before a vowel, prefixed and Changed forms of the verb are typically formed as if the third person prefix were doubled, giving underlying /wəw-/, as shown in (208).<sup>20</sup> Yet we clearly do not want to set up /wəw/ as the underlying form of the prefix in any other context.

- (208) a. n-ów-ikəwəss  
 1-3-mother-(AI)  
 'I have a mother'
- b. wew-ikəwəss-i-t  
 3-mother-AI-3  
 'he who has a mother'

In any event, this special treatment of verbs based on dependent nouns is not consistently maintained. Thus we find both n-ów-ipit and n-w-ípit (1-3-tooth-(AI)) 'I have teeth.' The Changed form of the prefix varies between wew- and ew-, so that ew-ikəwəss-i-t 'he who has a mother' occurs as an alternative to (208b).

Clearly not all of the variants of the third person prefix that appear in denominal verbs can be derived from a single underlying form. We have already seen that setting up underlying /wə(t)-/ for the third person prefix requires us to complicate our analysis of syncope by adding an additional deletion rule and marking the prefixes as exceptions to the usual treatment of initial /(C)ə [+sonorant]ə/. It therefore seems better to attribute the alternations which affect the shape of the third person prefix in denominal verbs to non-phonological allomorphy and derive the three prefixes in other contexts from underlying /n(t)-/, /k(t)-/, and /w(t)-/.

If the allomorphy approach is correct, it has a number of implications for our understanding of some of the rapid changes which have been taking place in Passamaquoddy. If -o(t)- and wə(t)- are not phonologically derived from the same underlying

form as the other surface variants of the third person prefix, then they offer only indirect evidence at best for underlying /w/ in this morpheme. For the youngest speakers, w shows up in the surface form of the prefix only in dependent nouns where it is followed by a vowel other than o. In other contexts, these speakers have only h or zero<sup>2</sup> for this /w/ (and in fact it is doubtful that this h is ever phonetically realized as [h] for these speakers). It would hardly be surprising if young speakers have come to interpret all of the alternations found in the third person prefix as allomorphic. Setting up a zero allomorph for the third person prefix would have far-reaching consequences, however, for the phonology of stem alternations, since it would remove the phonological basis for a distinction between prefixed and unprefixed forms in many cases. The fact that there is evidence of widespread leveling of stem alternations and redistribution of stem alternants might well be taken to indicate that such a reanalysis has taken place.

### 5.5 Deletion of / / before /hV/

Syncope takes place before /h/ in Passamaquoddy as well as before obstruents. Alternating vowels are found both before /hV/ and before /hC/, but alternations in these two environments are rather different in character. The segments which are lost before /hV/ appear to be best analyzed as underlying /ə/; while underlying /i/, /a/, and /o/, but not /ə/, undergo syncope before /hC/. Vowel/zero alternations are also carried out much more consistently before /hV/ than before /hC/. The cases in which deletion takes place before /hV/ are discussed in this section.

An analysis of deletion before /hC/ is given in Chapter 5. We can provide a simple account of syncope in both environments if we posit a general rule which deletes unstressable vowels before /h/. As we will see in Chapter 6, however, there is little reason to choose a unified analysis of syncope before /h/ over an alternative which would treat deletion before /hC/ as an extension of the process of pre-obstruent syncope.

Underlying /əhC/ occurs only in a few suffixes, and all such sequences contain inherently stressable /ə/ (at least if the analysis of syncope before /hC/ given in Chapter 6 is accepted). Syncope before /hV/ can therefore be stated as a rule which deletes floating /ə/ before /h/:

(209) Schwa Deletion II

②  $\rightarrow \emptyset / \_ h$

By ordering this rule, like Schwa Deletion I, after the rules of V-slot epenthesis, we can restrict deletion before /h/ to unstressable /ə/.

This formulation of Schwa Deletion II presupposes that the vowels which alternate with zero before /hV/ are represented as /ə/ in underlying forms. The choice of /ə/ as the underlying segment in these cases is consistent with the available data, but must be regarded as essentially arbitrary. Both syncompating and non-syncompating /e/, /a/, and /ə/ are subject to a rule which assimilates the first vowel in a /VhV/ sequence to the second. Thus the underlying quality of syncompating vowels before /hV/ cannot be directly determined. There is indirect evidence,

however, which favors the choice of underlying / / for the vowel which undergoes syncope before /h/ in a class of stems in which underlying /Vhəm/ is subject to syncope between /h/ and /m/ as well as to Schwa Deletion II. Since underlying /ə/ can be motivated for these cases, I will assume that other syncope vowels before /hV/ also have this source. If Schwa Deletion II is generalized as suggested in Chapter 6, however, it will in fact turn out that the choice of an underlying representation for these syncope vowels has no empirical consequences: the generalized rule will delete any floating vowel, regardless of its quality.

The first subsection below presents the alternations which motivate Schwa Deletion I, the second suggests a formal treatment of vowel assimilation across /h/, and the third states the argument for the choice of /ə/ as the segment which undergoes syncope before /hV/. The rule which deletes unstressable /ə/ between /h/ and /m/ is formalized in the following section.

### 5.5.1 Schwa Deletion II

The environment for syncope before /hV/ apparently arises only in about a dozen morphemes, but for the most part the rule is applied consistently where it is applicable. Three nouns in which a vowel alternates with zero before /hV/ are illustrated in (210)-(212). In each case I give first the hypothesized underlying form of the stem.

(210) a. /kəhəkən/

'door'

b. h-káhákən

3-door

'his door'

c. khákən

'door'

(211) a. /wətəhəkən/

'paddle'

b. htáhákən

'paddle'

c. óthákən

(3)-paddle

'his paddle'

(212) a. /məsəhon/

'heart'

b. psóhon

'heart'

c. məshon

(3)-heart

'his heart'

Comparable alternations in the medial /-əhikw-/ 'bark' and the TA and TI final /-əh-/ are shown in (213)-(215).



- (213) a. nát-ən-ihíkw-e  
 go-by.hand-bark-AI-(3)  
 'he goes and gets birchbark'
- b. mǝn-híkw-e  
 off-bark-AI-(3)  
 'he peels off bark'
- (214) a. pt-ihí-ke  
 hook-TA-AI-(3)  
 'he catches fish'
- b. n-pǝt-hí-k  
 1-hook-TA-AI  
 'I catch fish'
- (215) a. wíphon-h-áso  
 feather-TI-II-(3)  
 'it has a feather or feathers on it'
- b. mǝtewéke n-ah-áso  
 flag-TI-II-(3)  
 'it has a flag on it'

In most morphemes which show such alternations, deletion is obligatory where it is permitted, but there are a few cases in which syncope before /hV/ appears to be optional. For example, some speakers optionally retain an unstressable vowel before /hV/ in /-ǝkelə h-/ 'encourage to stay': ht-ǝkél(a)h-a-l 'he encourages the other to stay.'

It is easy to see that the vowel/zero alternations in (210)-(215) have the character of syncope. In (210), the first

vowel of the stem is retained after a personal prefix, but dropped in an unprefix form. In the other examples, the deletion or retention of the alternating vowels is determined by alternating stressability.

The examples in (216) and (217) show that cluster effects and the constraint on stressability in word-initial /((C)ə [+sonorant] ə/ play the same role in syncope before /hV/ as they do in pre-obstruent syncope. In (216), the initial vowel of /-əhól-/ TA 'ferry, transport by boat' is retained after the final cluster of /sakh-/ 'into view' but dropped after the single final consonant of /al-/ 'around.' In (217), the initial vowel of /-əhəm-/ 'swim' retained after /sakh-/ but dropped after /əl-/ 'thus, there' just as it is after /al-/.

(216) a. h-sákh-ohól-a-l

3-into.view-ferry-DIR-3.OBV

'he ferries the other into view'

b. ht-ál-hól-a-l

3-around-ferry-DIR-3.OBV

'he guides the other around

(i.e. takes the other around by boat  
on a fishing trip)'

- (217) a. sákh-ə́həm  
 into.view-swim-(3)  
 'he swims into view'
- b. ál-həm  
 around-swim-(3)  
 'he swims around'
- c. ə́l-h m  
 thus-swim-(3)  
 'he swims to that place'

The role of stressability in syncope before /hV/ follows from the same considerations as the parallel constraints on syncope before obstruents. Consider, for example, the final /-ə́həm-/ 'swim.' We will see in 5.6 that the second /ə/ of this morpheme is inherently stressable. Thus the syllabified underlying form of ál-həm (ignoring the third person suffix) is (218). No rule of V-slot epenthesis is applicable here, so the initial floating /ə/ of the final remains unstressable and is deleted by Schwa Deletion II.

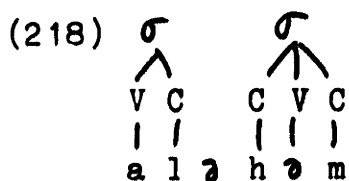

The underlying form of sákh-ə́həm, on the other hand, contains an unsyllabifiable consonant, as shown in (219a). This C-slot triggers V-Epenthesis, which inserts a slot for the first /ə/ of /-ə́həm-/, deriving (219b). Schwa Deletion II is not applicable in the resulting structure, so /ə/ is retained in this form.

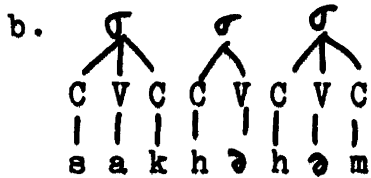
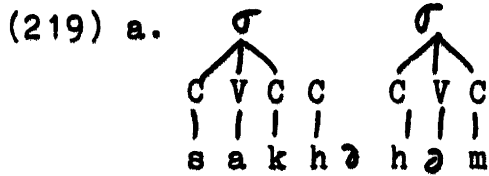

The syllabified underlying form of əl-həm is (220a). In this case, Initial Syllable Epenthesis is triggered by the unsyllabified /l/ of /əl-/, bleeding V-Epenthesis, since no C-slot remains unsyllabified in (220b). The initial /ə/ of /-əhəm-/ thus remains without out a slot and is deleted by Schwa Deletion II.

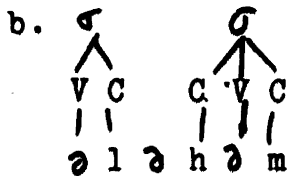
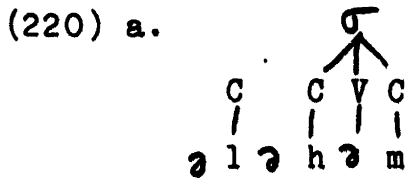

Since word-final /h/ does not occur in Passamaquoddy, either on the surface or in underlying forms, there are no derivations in which Final Syllable Epenthesis bleeds Schwa Deletion II. The remaining rule of V-slot epenthesis from Chapter 4, S-HS epenthesis is also irrelevant for the class of examples that we have been considering.

Given the marked character of floating vowels, we expect to find many morphemes in which syncope does not take place before /hV/. Such morphemes are, indeed, quite common:

- (221) a. áháhsew-ək  
horse-33PROX  
'horses'
- b. kóh-óti-k  
sleep-instrument-LOC  
'bed (loc.)'
- c. tpí-táha-t-áso  
heed(?)-think-TI-II-(3)  
'it is thought about'

These stable vowels generally appear to be stressable, as we would expect, although the first of two like vowels in VhV is typically quite short and weakly articulated, and may be phonetically destressed (see 3.3.3 for discussion).

### 5.5.2 VHV Assimilation

Both stable and syncoating vowels are subject to assimilation to a following vowel across /h/. The examples in (222) show the effects of assimilation in the stem /yVh-/, the allomorph of /-iy-/ TA 'tell' which is used in unprefixated forms. The vowel of /yVh-/ is inherently stressable, but its underlying quality is indeterminate. (The initial /y/ of /yVh-/ is dropped by most speakers when the stem vowel becomes /i/.)

- (222) a. yáh-à-n  
 tell-DIR-2  
 'tell (sg.) him/them!'
- b. yéh-èk  
 tell-11-(PERF)  
 'when we (exc.) told him/them'
- c. ih-í-n  
 tell-10BJ-2  
 'tell (sg.) me!'
- d. yoh-òsk  
 tell-3(3)/2  
 'he who tells you (sg.)'
- e. yáh-àkw  
 tell-12-(PERF)  
 'when we (inc.) told him/them'

In (223) we see the same pattern of assimilation in the stem /pət-əh-/ 'hook (a fish)'. In this case, however, the vowel before /h/ is underlyingly unstressable and is subject to syncope when it is in a position where it remains unstressable, as a comparison with the forms in (224) reveals.

- (223) a. pt-ah-à-t  
hook-TA-DIR-3AN-(SUBJ)  
'if he hooks the other'
- b. pt-eh-èk  
hook-TA-11-(SUBJ)  
'if we (exc.) hook him'
- c. pt-ih-i-hin  
hook-TA-1.OBJ-2-(SUBJ)  
'if you (sg.) hook me'
- d. pt-oh-òk  
hook-TA-1/3(3)-(SUBJ)  
'if I hook him/them'
- e. pt-ah-àt  
hook-TA-2/3(3)-(SUBJ)  
'if you (sg.) hook him/them'
- (224) a. h-pat-h-a-l  
3-hook-TA-DIR-3.OBV  
'he hooks the other'
- b. pet-h-à-t  
hook-TA-DIR-3AN-(PERF)  
'when he hooked the other'

For stable vowels before /h/ there is sometimes evidence from related forms which suggests what the underlying vowel must be. In all case that I have encountered in which there is evidence of this kind, the underlying vowel is /a/ or /e/. The root 'kill' and the medial 'strike' are typical examples. The underlying final vowels of these morphemes cannot be determined

on the basis of TA forms like those in (225) and (226), since these vowels are always subject to assimilation in the TA paradigms. But TI forms like those in (227) point to /nehpa-/ as the underlying form of the root 'kill' and /-ihte-/ as the underlying form of the medial 'strike.'

(225) a. k-néhpá-h-a-l

2-kill-TA-DIR-3.OBV

'you (sg.) kill him'

b. k-néhpí-h-i

2-kill-TA-1.OBJ

'you (sg.) kill me'

c. k-néhpó-h-ol

2-kill-TA-2.OBJ

'I kill you (sg.)'

(226) a. skàt... pc-íhta-h-à-h-kw

not accidentally-strike-DIR-NEG-3AN-(SUBJ)

'if he does not accidentally hit the other(s)'

b. skàt... pc-íhti-h-inəməhkw

not accidentally-TA-3(3)/11or12NEG-(SUBJ)

'if he/it/they does/do not accidentally strike

us (exc. or inc.)'

c. skàt... pc-íhtó-h-okó-li-hti-h-kw

not accidentally-TA-INV-OBV-33PROX-

NEG-3AN-(SUBJ)

'if it/they (in. obv.) does/do not accidentally

hit them (prox. an.)'



(227) a. néhpá-hto-n

(3)-kill-TI-3IN

'he kills it (e.g. a plant)'

b. ht-ətəl-ihté-h-m-ən

3-ongoing-strike-TI-TI-3IN

'he is hitting it'

Although there are few relevant examples, /i/ apparently does not undergo assimilation before /hV/, since underlying /ihV/ remains undisturbed in forms like pəm-ákəmí-həm (along-snowshoe-AI-(3)) 'he goes along on snowshoes' and ési-h-ə-k (give.drink-TI-TI-3AN-(PERF)) 'when he watered it.' There are no clear examples in which /o/ is in a position to undergo assimilation, since /h/ is regularly replaced by /w/ after /o/, as discussed in 3.3.3.

The simplest way to prevent /i/ from undergoing assimilation in /VhV/ is to require targets of assimilation to be [-high]. But an assimilation rule which is formulated in these terms will be applicable to /ə/ as well as to /a/ and /e/, since /ə/ is presumably also [-high]. Thus it is plausible that /ə/ is the phonological source of the vowels which alternate with zero before /hV/.

The choice of a formal statement for the rule assimilation takes place in /VhV/ depends on how we decide to represent /h/. Phonetically, the output of assimilation is a span of three segments which share the same specifications for all of the non-laryngeal features. If only laryngeal features are specified for /h/ in underlying forms, and if these features are represented on a separate tier, then assimilation in this case can be

interpreted as a process by which the non-laryngeal features associated with the second V-slot in /VhV/ spread leftward, so that they come to be associated with three timing slots. We can then state the rule of VHV Assimilation as follows:

(228) VHV Assimilation

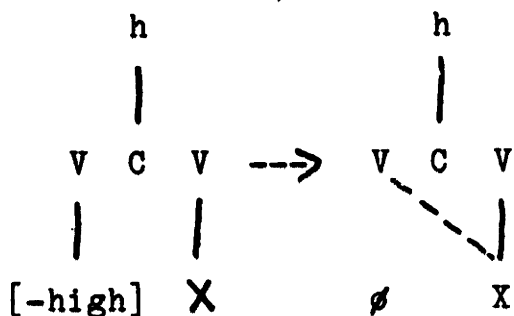

As we saw in 3.3.3, we can account for the fact that the first V in VhV is not subject to Penultimate Lengthening if we assume that the output of VHV Assimilation is a multiply linked structure. Thus there is support for a formulation of this process like that given in (228) from the phonetic properties of the output of assimilation.

**5.5.3 Syncope before /hV/ is schwa-deletion**

A few verb stems contain underlying sequences of the form /Vhəm/ which may undergo either the rule for syncope before /hV/ which we have been looking at in this section or the rule for syncope between /h/ and /m/ which is discussed in the following section. An example is /pət-əh-əm-/ 'hook a fish,' which is formally a TI stem but may also be inflected as an AI verb. The

interesting point about stems of this type is that the V in /Vhəm/ surfaces as a when the following /ə/ is deleted:

- (229) a. pt-əh-əm  
hook-TI-TI-(3)  
'he hooks a fish'
- b. pt-ah-m-ok  
hook-TI-TI-(3)-33PROX  
'they (du.) hook fish'

Compare pet-h-ə-k (hook-TI-TI-3AN-(PERF)) 'when he hooked a fish,' where the vowel before /h/ in this stem undergoes syncope instead.

From a historical point of view, a occurs in these forms simply because Proto-Eastern Algonquian \*a is retained as a before hC in Passamaquoddy, rather than becoming ə as it does in other environments. (See 6.5 for some discussion of the history of the Passamaquoddy vowel system.) A synchronic analysis which recapitulates the history of the forms in question will therefore set up underlying /-ah-/, with underlyingly unstressable /a/, for -əh- ~ -ah- ~ -h-.

Although Schwa Deletion I, as formulated in (209), will not delete underlying /a/, there is nothing to prevent us from formulating a rule which will delete unstressable /a/ as well as (or instead of) unstressable /ə/. As I noted at the beginning of this section, a generalization of Schwa Deletion I with precisely this effect will be proposed on other grounds in Chapter 6.

There is indirect evidence, however, which favors an alternative synchronic analysis which take /-əh-əm-/ to the the

underlying form of the alternating sequence in (229). Surface forms with -ah-m-, in this analysis, reflect the application of a rule which lowers /ə/ to /a/ before /hm/:

(230) ə ----> ə \_\_\_\_ hm

Such a rule would in fact be exceptionless, since ə does not occur before hm in surface forms. (The few Conjunct negative affixes in which əhC is attested all have hkw. See (226b) above for an example.)

The evidence in question comes from verb stems in which an alternation between əhəm and ehm is apparently being replaced by one between əhəm and ahm. Some examples are given in (231) and (232).

(231) a. íkətáhəm  
 yawn-(3)  
 'he yawns'  
 b. íkətéhm-ok  
 ~ íkətáhm-ok  
 yawn-(3)-33PROX  
 'they (du.) yawn'

(232) a. ámskwáhs-okən-áhəm  
 first-day-II-(3)  
 'it is the first day of the month'  
 b. ámskwahs-ókən-ehm-óhpən  
 ~ ámskwahs-ókən-ahm-óhpən  
 first-day-II-(3)-PRET  
 'it was the first day of the month'

Presumably the forms with e reflect underlying /ikətehəm-/ and /amskwahs-okən-ehəm-/, with assimilation across /h/ in (231a) and (232a) and syncope between /h/ and /m/ in the (b) examples. But how should we analyze the alternants with a?

At least for the stem in (231), it appears that forms with e represent the older type, while forms with a are innovations. Karl Teeter and I have recorded íkətèmmok 'they (du.) yawn' for Woodstock Maliseet, with the change of \*hm to mm which is characteristic of this dialect. (Woodstock still has íkətəhəm 'he yawns.') Since Woodstock forms of this type are apparently not subject to the variation that we find in Passamaquoddy, Woodstock íkətèmmok points to /ikətehəm-/ as the original shape of the stem in (231).

Why should ahm be spreading at the expense of ehm, rather than the other way around? One way to make sense of this change is to suppose that it involves reanalysis of underlying /ehəm/ as /əhəm/. This kind of reanalysis will result if the simplest type of third person singular form of the Independent Indicative mode is used as a basis for establishing the underlying form of the stem of a verb like íkətəhəm, since it is precisely in this form that the surface sequence əhəm appears. If speakers have analyzed the alternation between əhəm and ahm as a consequence of the lowering rule (230), then reanalyzing /ehəm/ as /əhəm/ will automatically result in the extension of forms with ahm at the expense of forms with ehm.

We see, then, that the variation between ahm and ehm that we find in contemporary Passamaquoddy lends support to the hypothesis that ahm is synchronically derived from /əhəm/. This

conclusion gives us a reason to postulate underlying /ə/ for some of the vowels which undergo syncope before /hV/. If these cases may serve as a guide, we will derive all of the vowels which undergo syncope in this environment from underlying /ə/.

### 5.6 Deletion of /ə/ between /h/ and /m/

A third rule deleting /ə/ is required to account for the fact that /ə/ alternates with zero between /h/ and /m/. Deletion is again limited to unstressable /ə/, a restriction which we can express as before by formulating Schwa Deletion III so that it applies only to unassociated schwas. Virtually all occurrences of surface hm are synchronically derived by this rule.

Where we expect hm to surface in word-final position as a result of the application of Final Vowel Deletion, we instead find only m. I therefore postulate a rule which follows Final Vowel Deletion and deletes /h/ before word-final /m/.

#### 5.6.1 Schwa Deletion III

The rule which deletes unstressable /ə/ between /h/ and /m/ may be stated as follows.

#### (233) Schwa Deletion III

② --> ø / h \_\_\_\_ [+sonorant]

The sound change which this rule reflects introduced the clusters hl and hn as well as hm, but only hm continues to alternate in the contemporary language.

One type of alternation which results from the application of Schwa Deletion III may be seen in the following examples, which were briefly discussed above in 5.5.3.

(234) a. íkətáhəm

yawn-(3)

'he yawns'

b. íkətéhəm-ok

~ íkətáhm-ok

yawn-(3)-33PROX

'they (du.) yawn'

(235) a. ámskwáhs-okən-əhəm

first-day-II-(3)

'it is the first day of the month'

b. ámskwáhs-ókən-əhm-óhpən

~ ámskwáhs-ókən-ahm-óhpən

first-day-II-(3)-PRET

'it was the first day of the month'

The variation between e and a in the (b) examples in (234) and (235) I have attributed to variation in the underlying form of the stems: 'yawn' is underlyingly either /íkətéhəm-/ or /íkətáhəm-/; 'be the first day of the month' is either /ámskwáhs-okən-əhəm-/ or /ámskwáhs-okən-əhəm-/. Schwa is lowered to /a/ before /hm/ in the output of Schwa Deletion III. Either underlying stem can be the source of the (a) forms, since non-high vowels are assimilated to a following vowel across /h/ by VHV Assimilation.

In (234a) and (235a), we see that /ə/ is not deleted by Schwa Deletion III when it is the last underlying vowel of a word. We can account for this restriction on Schwa Deletion III just as we accounted for the corresponding restriction on Schwa Deletion I: by ordering Schwa Deletion III after Final Syllable Epenthesis. When ikətəhəm is based on the stem /ikətəhəm-/, it has the syllabified underlying form shown in (236a). The deletion of the third-person suffix turns (236a) into (236b). Final Syllable Epenthesis then converts this structure into (236c).

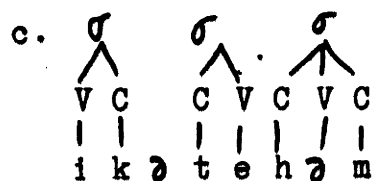
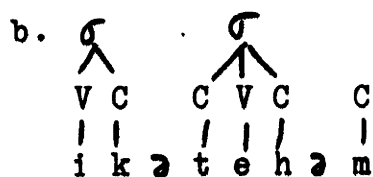
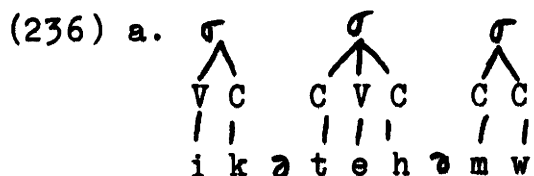

Since the /ə/ between /h/ and /m/ in this form is now associated with a V-slot, Schwa Deletion III is not applicable. If Schwa Deletion I applied regularly in this word, we would derive surface \*iktəhəm. The first /ə/ of /ikətəhəm-/ ~ /ikətəhəm-/ is an exception to this rule, however, so it is not subject to syncope, and Schwa Support derives (237a) from (236c). The application of VHV Assimilation gives (237b).



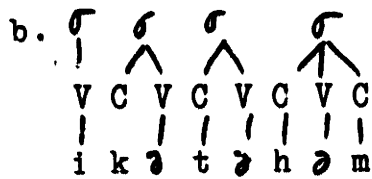
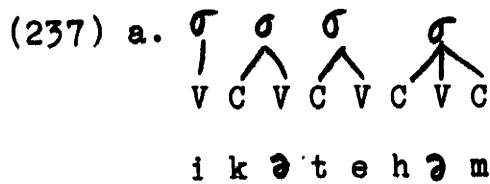

Consider now the derivation of íkətáhm-ok 'they (du.) yawn.' This form is based on the stem alternant /ikətəhəm-/. A plausible representation of the syllabified underlying form of this word is that shown in (238). (The /ə/ of /-ək/ 33PROX is inherently stressable. The second /ə/ of the stem could be analyzed as inherently stressable as well, since the fact that the last vowel before it is unstressable guarantess that it will always be treated as stressable.)

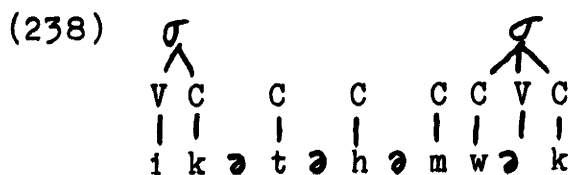

The leftmost unsyllabified C in this representation is the one associated with the /t/ of the stem. This C' triggers V-Epenthesis, with results as shown in (239).

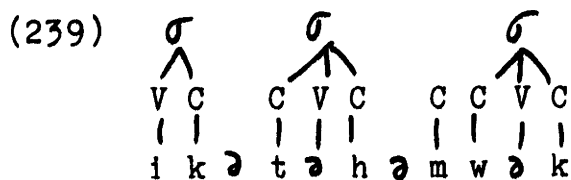

At some point in the derivation of this word, the sequence /wə/ in the ending /-w-ək/ contracts to /o/. After this contraction,

the final /m/ of the stem is syllabifiable. Nothing turns on the ordering of this contraction, however. Since /m/ is not followed by a floating /ə/ in (239), V-Epenthesis is not applicable to this representation, even though it contains an unsyllabified C. Schwa Deletion I does not apply to the first /ə/ in (239) because this vowel is marked as exceptional. Schwa Deletion III is applicable, however. Its output is (240).

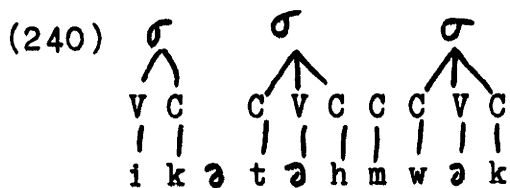

Schwa Support and the contraction of /wə/ to /o/ convert (240) to (241a). The lowering of /ə/ to /a/ before /hm/ then gives (241b). (The order of these last steps is again not crucial.)

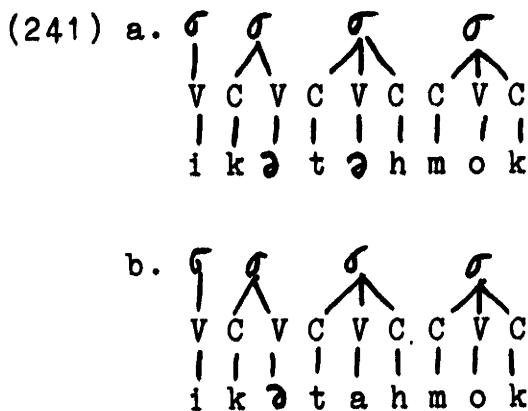

V-Epenthesis may also bleed Schwa Deletion III. A look at the paradigm of the stem /pət-əh-əm-/ TI 'hook (as a fish)' will illustrate the ways in which these rules interact. The examples in (242) show how this stem appears in prefixed, unprefixed, and Changed forms.

- (242) a. h-p<sup>á</sup>t-h-<sup>á</sup>m-<sup>à</sup>n  
 3-hook-TI-TI-3IN  
 'he hooks it'
- b. pt-<sup>á</sup>h-m-<sup>à</sup>n  
 hook-TI-TI-1-(SUBJ)  
 'if I hook it'
- c. p<sup>é</sup>t-h-<sup>à</sup>m-<sup>à</sup>n  
 hook-TI-TI-1-(PERF)  
 'when I hooked it'

In the underlying form of (242a), which is shown in (243a), no segments can be syllabified, since all of the vowels are "invisible." Final Syllable Epenthesis provides a V-slot for the last /ə/ of the word, however, so syllabification begins as shown in (243b).

- (243) a. C C C C C C  
 | | | | | |  
 w p ə t ə h ə m ə n
- b.
- σ
- / \
- C C C C C V C  
 | | | | | | |  
 w p ə t ə h ə m ə n

The leftmost C' in (243b) which is eligible to trigger V-Epenthesis is the one associated with the initial /p/ of the stem. Epenthesis is followed by another application of the basic syllabification rules, with results as shown in (244a). Since the C associated with the /h/ of /-əh-/ remains unsyllabified in the latter structure, V-Epenthesis applies again, deriving (244b).

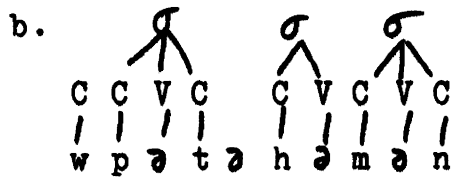
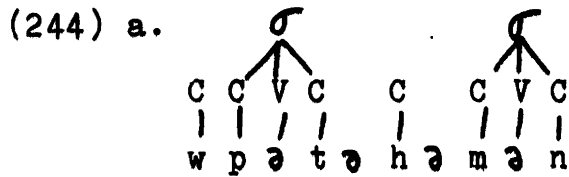

This second application of V-Epenthesis provides a slot for the /ə/ in underlying /həm/, so Schwa Deletion III is not applicable here. The underlying /ə/ of /-əh-/ remains unstressable, however, and is eliminated by Schwa Deletion II:

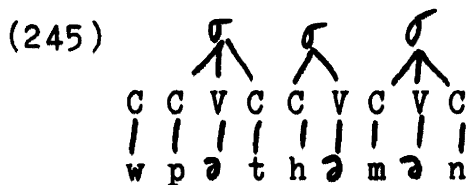

Word-initial /wp/ ordinarily surfaces as hp as a result of the the application of Initial Devoicing.

Both (242b) and (242c) are pronounced with the final rising intonation which is characteristic of words which have undergone Final Vowel Deletion. In Chapter 10 I will argue that forms like these end with modal suffixes which consist only of an empty V-slot, the subjunctive and perfective suffixes. (For a discussion of the perfective/imperfective distinction in Passamaquoddy, see the beginning of Chapter 9.) On this assumption, the syllabified underlying form of (242b) is (246).

(246)

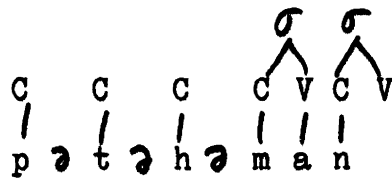

The word-initial unsyllabified /p/ of (246) is extrametrical. Thus the leftmost potential trigger of V-Epenthesis is the second C' in the word. The application of this rule gives (247)

(248)

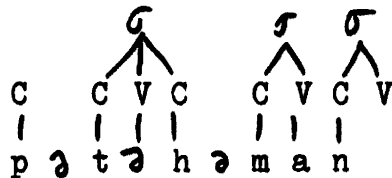

Since /h/ can now be incorporated into a syllable, V-Epenthesis does not apply again. Two floating schwas remain. The first precedes /t/, an obstruent. It is therefore deleted by Schwa Deletion I. The second stands between /h/ and /m/. Here Schwa Deletion III is applicable. The output of these two rules is (249a). Schwa is now lowered to /a/ before /hm/, giving (249b). Word-final empty V must also be deleted, since the /n/ of /-an/ surfaces as the final consonant of the preceding syllable, as shown in (249c).

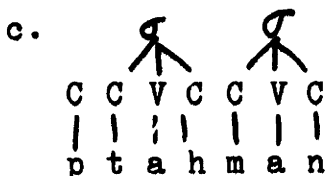
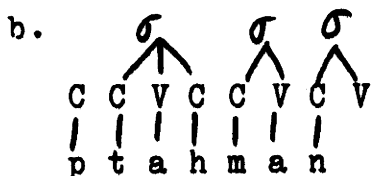
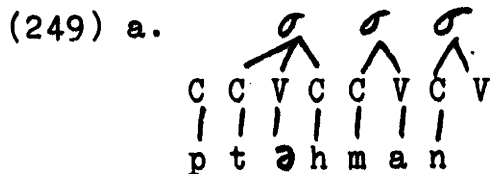

Initial Change gives /pet-/ for /pət-/ in (242c). Like other occurrences of /e/, /e/ derived by Initial Change is stressable. Thus the syllabified underlying form of (242c) is (250).

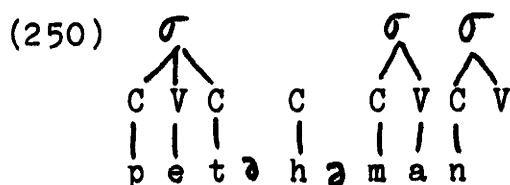

Since the /t/ of /pet-/ is syllabifiable, it does not trigger V-Epenthesis. The /h/ of /-əh-/ remains unsyllabified, however, so it triggers this rule instead, converting (250) into (251a). The /ə/ between /h/ and /m/ is now associated with a V-slot. Schwa Deletion III is therefore inapplicable. Schwa Deletion II applies, however, deleting /ə/ before /h/ as shown in (251b). With the loss of word-final empty V, we derive (251c), as required.

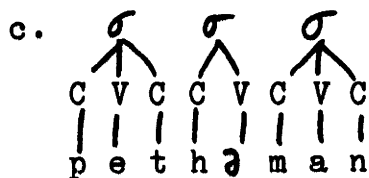
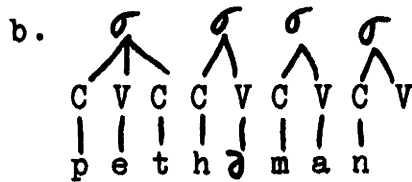
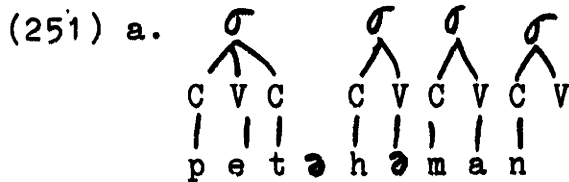

The interaction of V-Epenthesis with Schwa Deletion I, II, and III also accounts for the vowel/zero alternations in the paradigm of hkəphəmən 'he shuts it,' but variation in the underlying shape of /kəp-/ ~ /kəpp-/ 'close' (as discussed in 5.2.12) results in doublets for prefixed and Changed forms:

- (252) a. h-kəp-h-əm-ən  
 ~ h-kəpp-əh-m-ən  
 3-close-TI-TI-3IN  
 'he shuts it'
- b. kp-əh-m-ən  
 close-TI-TI-2  
 'shut (sg.) it!'
- c. kəp-h-ə-k  
 ~ kəpp-əh-ə-k  
 close-TI-TI-3AN-(PERF)  
 'when he shut it'

The first alternant in (252a) has the underlying form shown in (253a.) Final Syllable Epenthesis and two applications of V-Epenthesis derive (253b). Schwa Deletion II then yields (253c).

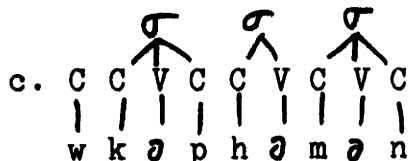
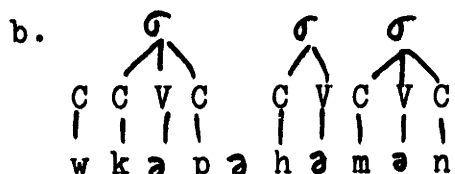
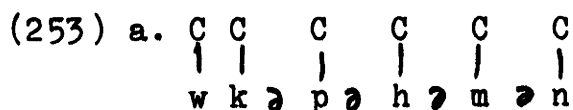

In the underlying form of hk ppahm n, the /p/ of 'close' is associated with two C-slots instead of one:

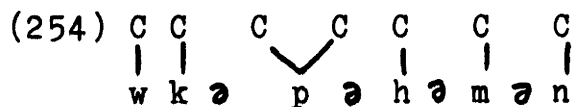

Final Syllable Epenthesis applies as before, yielding (255a). V-Epenthesis again applies twice, but in this case the second application of the rule associates a V-slot with the /ə/ which immediately follows /kəpp-/. A floating /ə/ therefore remains between /h/ and /m/ in (255c) and is deleted by Schwa Deletion III.



(255) a.

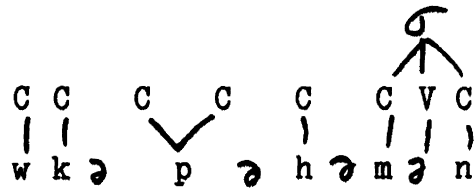

b.

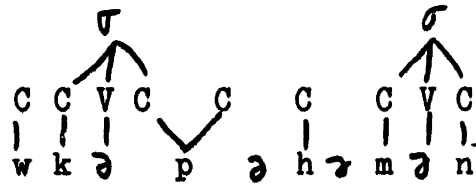

c.

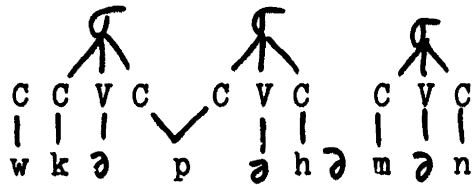

d.

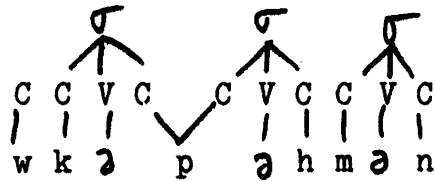

Initial Devoicing and the lowering of /ə/ to /a/ before /hm/ derive hkəppáhman from (255d).

In unprefixated forms like kpáhman 'shut (sg.) it!' the distinction between /kəp-/ and /kəpp-/ is lost, since both are reduced to surface kp-. The alternative underlying forms are shown in (256).

(256) a.

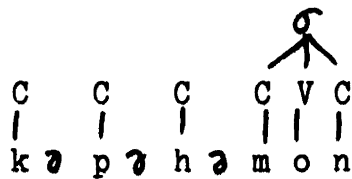

b.

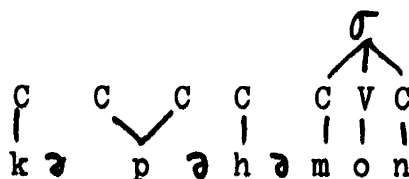

The first C in these forms is not a possible trigger of V-Epenthesis, since it is extrametrical. The second C of (256b) is not a possible trigger either, since it is not followed by a floating /ə/. Thus the second C of (256a) but the third C of (256b) trigger V-Epenthesis, with results as shown in (257).

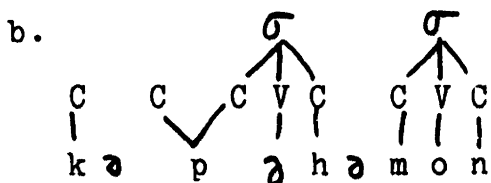
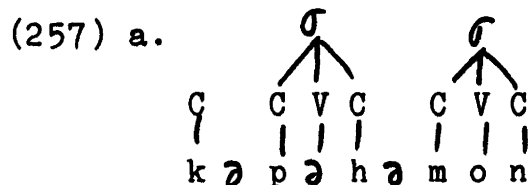

Schwa Deletion I removes the first /ə/ in each form and Schwa Deletion III removes the third:

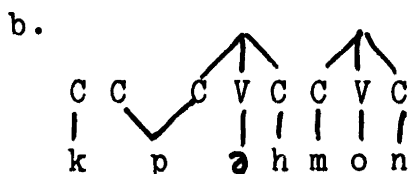
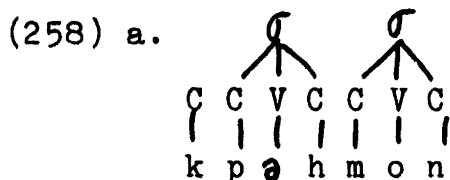

Since /pp/ is reduced to /p/ after another non-syllabic and /ə/ becomes /a/ before /hm/, both forms surface a kpəhmòn. (The grave accent of the final syllable of this word is a lexical property of the imperative singular suffix /-(o)n/.)

Initial Change replaces the unstressable /ə/ of /kəp(p)-/ with stressable /e/ in képhək ~ képpəhək 'when he shut it.'

Schwa is deleted after plain /p/ but retained after /pp/, following the same pattern as in hkəphəməŋ ~ hkəppəh məŋ. Stem-final /m/ is deleted before /-k/ 3AN by the morphologically governed rule of Nasal Deletion. (Regular application of Schwa Deletion I would result in the loss of the last /ə/ in kəppəhək, but the /ə/ of the TI element /-əm-/ is usually treated as an exception to this rule.)

One apparent exception to Schwa Deletion III can be accounted for by analyzing the /ə/ in question as inherently stressable. The final /-əhəm-/ AI 'swim' is shown in its full form in (259a). The loss of the first /ə/ of this morpheme in (259b) is regular, since an unstressable vowel is deleted after a stressable vowel, as we will see in 8.2. The second /ə/ of /-əhəm-/ should also be deleted in this form, however, if it is an underlying floating vowel, since we would expect Schwa Deletion III to be applicable here. Unexpectedly, this /ə/ is retained on the surface -- and stressed. I therefore propose (260) as the underlying representation of /-əhəm-/.

- (259) a. sakh-ə́həm  
 into.view-swim-(3)  
 'he swims into view'
- b. máce-hə́m-əne  
 start-swim-11  
 'let's (du.) swim away'

- (260)     C V C  
           | | |  
           ə h ə m

The treatment of /-əhəm-/ shown in (259b) is apparently the result of a Passamaquoddy innovation: Woodstock Maliseet has máçé-mm-ok (start-swim-(3)-33PROX) 'they (du.) swim away,' presumably reflecting earlier \*máçé-hm-ok with loss of the second /ə/ of /-əhəm-/ by Schwa Deletion III.

If the analyses given above are accepted, then neither the variable pattern of syncope in hkápháman ~ hkáppáman 'he shuts it' nor the retention of /ə/ between /h/ and /m/ in máçéhámáne 'let's (du.) swim away' involves an exception to Schwa Deletion III. In fact this rule seems to be completely general.

Virtually all occurrences of hm in Passamaquoddy appear to be synchronically derived from /həm/. One elderly consultant (S.G.) has non-alternating hm in nəhm 'turkey,' which should probably be analyzed as underlying /nehmi-/ (cf. néhmíyək 'turkeys,' néhmíməl 'his turkey'); but other speakers have m in this word (nəm 'turkey,' némiyik 'turkeys'). Some speakers have múhmum, múhmúmi for 'grandfather,' probably in origin baby-talk forms of múhsumí 'grandfather (voc.).'

It should also be pointed out that some derived occurrences of hm are not in paradigmatic alternation with həm. For example, the hm of ht-ətəl-ihté-h-m-ən (3-ongoing-strike-TI-TI-3IN) 'he is hitting it' alternates with hə in forms like étəl-ihtə-h-ə-k (ongoing-strike-TI-TI-3AN) 'he is hitting it (Conjunct),' but every form of this verb is subject either to Schwa Deletion III or to Nasal Deletion, preventing /həm/ from surfacing as such. The underlying stem /mənoh-əm-/ TI 'buy' can be justified on the basis of mánóh-m-ən ((3)-buy-TI-3IN) 'he buys it' and ménow-ə-k (buy-TI-3AN-(PERF)) 'when he bought it,' given

the rule of H-Assimilation proposed in 3.3.3, but here again /həm/ will never surface without undergoing some modification.

In a word like nápisqwáhma 'he trips,' hm is not in a position to alternate with any sequence containing ə. In some cases of this type, underlying /həm/ can be recovered on the basis of a derivationally related form, but apparently not here: for íkətél a ~ íkətáhma 'he yawns' there is íkətáhəm, in the same meaning; for ptáhma 'he hooks a fish' there is ptáhəm; but there seems to be no \*nápisqwáhəm corresponding to nápisqwáhma. Note also ht-í m-ów-a-n (3-have-TI-TA-DIR-PEG) 'he has that of the other's' and éy-m-ow-i-t (have-TI-TA-1.OBJ-3AN-(PERF)) 'when he had that of mine,' TA+O forms corresponding to TI ht-íhi-n (3-have-3IN) 'he has it' and éyi-t (have-3AN-(PERF)) 'when he had it.' If the suggested segmentations of the former are correct, then the stem of htíhmówan is underlying /-ih-əm-əw-/, with the TI element /- m-/, but the phonology of these forms is obscure.

### 5.6.2 H-Deletion II

Except in nəhm 'turkey' (a by-form of nəm, as noted above), /h/ is deleted before /m/ whenever /hm/ comes to stand in word-final position as a result of the application of Final Vowel Deletion:

(261) H-Deletion II

hm → ø / \_\_\_ m #

The application of this rule is attested only in two categories of verb forms, first person singular Changed Conjunct forms of AI and TI verbs and first and second person singular Independent Indicative forms of AI verbs. Environments for the application of the rule should also arise in singular imperative forms of AI verbs, but I have no relevant examples.

The Conjunct first person singular suffix is underlying /-an-/ before another suffix but /-a/ in word-final position. The perfective morpheme /-V/ counts as a suffix for this choice, so Conjunct perfective and imperfective forms are distinguished not only by the underlying presence or absence of an abstract final vowel but also by the allomorph of /-an-/ which they require. Since the vowel of the word-final allomorph /-a/ is always subject to Final Vowel Deletion, its underlying form is quite abstract as well.

I will return to this complex of phenomena in Chapter 10. For present purposes it is enough to note that first person Conjunct imperfective forms have zero where the corresponding perfective forms have an: imperfective élamiy-yà-y (away-go-1) 'as I left' corresponds to perfective élamí-ya-yàn (away-go-1-(PERF)) 'when I left' (the y of -y ~ -yan- is epenthetic). The first person singular suffix also surfaces without an in final position in participles: participle él-áp-əm-əki (thus-look-TA-PASS-1) 'the way I am looked at' corresponds to perfective él-áp-əm-əki-yàn (thus-look-TA-PASS-1-(PERF)) 'when I was looked at.'

Consider, then, the verb ht-əsi-h-m-n (3-give.drink-TI-TI-3IN) 'he waters it.' By comparing this form with ési-h-ə-k

(give.drink-TI-TI-3AN-(PERF)) 'when he watered it,' we can see that hm arises here by syncope in underlying /həm/. Where the first person suffix /-a/ is reduced to zero by Final Vowel Deletion, /h/ is deleted in resulting word-final /hm/:

- (262) a.  $\acute{e}si-h-m-\grave{a}n$   
 give.drink-TI-TI-1-(PERF)  
 'when I watered it (perfective)'
- b.  $kis-si-\underline{m}$   
 past-give.drink-(TI)-TI-(1)  
 'when I watered it (imperfective)'
- c.  $n\grave{i}l \grave{a}c \ n\grave{i}t \quad \acute{e}si-\underline{m}$   
 I FUT that(in.) give.drink-(TI)-TI-(1)  
 'I am the one who will water it'

Note that H-Deletion II applies in the derivations of (262b,c) because Final Syllable Epenthesis is not applicable in a structure like (263), the syllabified underlying representation of  $\acute{e}sim$ .

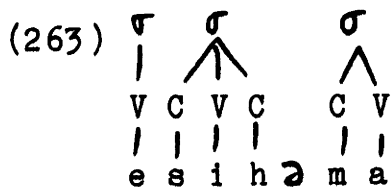

Further examples of the application of H-Deletion II in first person singular Conjunct forms are given in (264)-(266). The first two pairs of examples show the alternation between hm and m in TI forms; the third pair shows the same alternation in AI derivatives of /pət-əh-əm-/ 'hook a fish.'

- (264) a.  $\acute{e}t\acute{a}l-ihte-h-m-\grave{a}n$   
 ongoing-strike-TI-TI-1-(PERF)  
 'when I was hitting it'
- b.  $\acute{e}t\acute{a}l-ihte-m$   
 ongoing-strike-(TI)-TI-(1)  
 'I am hitting it'
- (265) a.  $h-kis-\grave{a}noh-m-\grave{a}n$   
 3-past-buy-TI-3IN  
 'he bought it'
- b.  $kis-\grave{a}no-m$   
 past-buy-TI-(1)  
 'when I bought it (imperfective)'
- (266) a.  $w\acute{e}l\acute{i} pt-ah-m-\grave{a}n$   
 good hook-TI-TI-1-(PERF)  
 'when I caught a lot of fish'
- b.  $\acute{e}t\acute{a}li w\acute{e}l\acute{i} pt-a-m$   
 ongoing good hook-(TI)-TI-(1)  
 'where I had been hooking fish well'

The environment for the application of H-Deletion II also arises in unsuffixed forms of AI verbs, since here too final vowels are subject to deletion. The examples in (267) show hm in alternation with m in an AI Independent Indicative paradigm:



- (267) a. nápískwám  
 (1)-trip  
 'I trip'
- b. k-nápískwám  
 2-trip  
 'you (sg.) trip'
- c. k-nápískwáhmá-pə́n  
 2-trip-11  
 'we (du. inc) trip'

Because the singular imperatives of most AI verbs are also suffixless, similar alternations are expected in imperative paradigms.

### 5.7 Schwa deletion and geminate formation

Unstressable /ə/ is deleted between identical non-syllabics, whether they are sonorants or obstruents, requiring us to postulate a fourth syncope rule, which I will call Schwa Deletion IV. Since Schwa Deletion I regularly deletes unstressable /ə/ before obstruents, it is to be expected that this rule will sometimes generate sequences of identical consonants; but schwas which are exceptions to Schwa Deletion I consistently undergo Schwa Deletion IV, showing that the latter rule is not limited to deleting /ə/ between sonorants. Geminates arising through either deletion process are pronounced as long versions of the corresponding single consonants or glides and are indistinguishable from underlying geminates. Length is

phonetically realized in the stop component of the complex segments c and kw.

A natural approach to this complex of phenomena would be to suppose that both Schwa Deletion I and Schwa Deletion IV may give rise to sequences of identical non-syllabics, which are then subject to a rule of geminate formation. Geminate formation will produce a multiply linked structure for derived geminates identical with that which may be assumed as the base form of underlying geminates.

Two shared peculiarities of geminate formation and Schwa Deletion IV suggest, however, that this initially attractive analysis is incorrect. Both processes treat a sequence of /t/ and /c/ as equivalent to a sequence of /c/ and /c/, but distinguish these from /c/ followed by /t/. Yet both processes treat /k/ and /kw/ as equivalent, so that no corresponding asymmetry shows up in the treatment of these segments.

I will argue below that geminate formation takes place in two steps. When two identical non-syllabics are adjacent, the segmental material of the first is deleted, leaving behind an empty C position. This empty C-slot is then linked with segmental material associated with the C-slot to its right. Schwa Deletion IV, when correctly formulated, can be collapsed with the deletion portion of geminate formation, allowing us to write a single rule for both purposes, which I call Geminate Deletion.

### 5.7.1 Deletion of /ə/ between sonorants

The deletion of unstressable /ə/ between two occurrences of /l/, /m/, or /n/ is illustrated in (268) and (269). The finals /-əlaməŋ-/ 'wind,' /-əlan-/ 'rain,' /-əm-/ 'by mouth,' and /-ən-/ 'by hand' are shown in (268) in environments in which they retain their initial schwas. In (269), where these schwas come to stand between identical consonants, they are deleted.

- (268) a. mən-əlaməŋ  
 off-wind-(3)  
 'the wind blows something off'
- b. kīs-əlan  
 past-rain-(3)  
 'it rained'
- c. ht-ətəl-əm-a-l  
 3-ongoing-by.mouth-DIR-3.OBV  
 'he is eating the other'
- d. h-təm-ən-əm-ən  
 3-in.two-by.hand-TI-3IN  
 'he breaks it in two by hand'

- (269) a. təl-lámsən  
 ongoing-wind-(3)  
 'the wind is blowing'
- b. wəl-lámsən  
 good-wind-(3)  
 'there is a nice breeze, a wind from  
 a good direction, etc.'
- c. təl-lan  
 ongoing-rain-(3)  
 'it is pouring (rain)'
- d. h-təm-m-a-l  
 3-in.two-by.mouth-DIR-3.OBV  
 'he bites the other in two'
- e. mən-n-əm- n  
 (3)-off-by.hand-TI-3IN  
 'he peels it off'

The deletion of unstressable /ə/ in /wəw/ is shown in (270)-(272). (A similar contraction of /yiy/ to yy will be discussed in 8.3.1.) I first give examples of the roots /maw-/ 'together in a group' and /nihtaw-/ 'know how, be good at' in (270). (Syncope of /i/ and Initial Devoicing reduce /nihtaw-/ to htaw- in unprefixated forms.) The medial /-əw(e)-/ 'hair, fur' and the finals /-əwehke-/ 'use' and /-əwikhike-/ 'write, draw, photograph, etc.' are shown in (271). (Both finals are derived from stems; cf. wéhkè-n (use-2) 'use (sg.) it!' and wík-hí-ke (write-TA-AI-(3)) 'he writes, draws, etc.')

The examples in

(272) show the loss of /ə/ in /-əw(e)-/, /-əwehke-/, and /-əwihkhike-/ after /w/.

(270) a. máw-ə́n-à`

(3)-group-by.hand-DIR-(33.OBV)

'he gathers the others'

b. htáw-ə́lónke

know.how-work-(3)

'he is good at doing (some kind of) work'

(271) a. wá́l-ə́wé-n-a-l

(3)-good-hair-by.hand-DIR-3.OBV

'he fixes (arranges, sets, etc.) the other's hair'

b. n-kís-ə́wéhka-n

1-past-use-3IN

'I used it'

c. tá́l-ə́wikhíke

ongoing-write-(3)

'he is writing'

(272) a. máw-é́-n-a-l

(3)-group-hair-by.hand-DIR-3.OBV

'he ties back the other's hair'

b. máw-é́hka-n

group-use-UNSPEC

'it is being used (by a group)'

c. htáw-wikhíke

know.how-write-(3)

'he knows how to write'

Since Schwa Deletion IV affects only unstressable /ə/, shifts in the pattern of alternating stressability induced by prefixation or Initial Change can make a /ə/ a target of the rule in one occurrence of a morpheme and a non-target in another. The /ə/ following /ətəl-/ 'ongoing' is deleted in (273a) and (274a) because it is the third /ə/ in a span within which alternating stressability holds. The addition of a prefix in the (b) examples takes the first /ə/ out of the count, as does Initial Change in the (c) cases. The /ə/ following /ətəl-/, now stressable because it is in second place, is retained in the surface in these forms.

- (273) a. təl-látəm  
 ongoing-breathe-(3)  
 'he is breathing'
- b. nt-ətəl-əlátəm  
 1-ongoing-breathe  
 'I am breathing'
- c. étəl-əlátə-k  
 ongoing-breathe-3AN  
 'he who is breathing'

- (274) a. t<sup>́</sup>əl-l<sup>́</sup>ohke  
 ongoing-work-(3)  
 'he is working'
- b. kt-ə<sup>́</sup>təl-əl<sup>́</sup>ohkè-pən  
 2-ongoing-work-11  
 'we (du. inc.) are working'
- c. étəl-ə<sup>́</sup>lohke-t  
 ongoing-work-3AN  
 'he who is working'

We can easily restrict Schwa Deletion IV to unstressable /ə/ by formulating this rule, like the other rules of syncope proposed above, as an operation deleting floating /ə/. A preliminary formal statement is given in (275).

(275) Schwa Deletion IV (preliminary)

$$\textcircled{\text{ə}} \rightarrow \emptyset \quad / \quad \begin{array}{cc} \text{C} & \text{C} \\ | & | \\ \text{X} & \text{Y} \end{array}$$

Condition: X = Y.

The interaction of (275) with Initial Syllable Epenthesis, V-Epenthesis, and Final Syllable Epenthesis will then account for the way the conditions on stressability determine where syncope takes place between identical non-syllbics.

The role of Initial Syllable Epenthesis and V-Epenthesis may be seen by looking at a series of derivatives of /-əlohke-/ 'work, do': míl-l<sup>́</sup>ohke 'he does various things, causes various

kinds of trouble' (with /mil-/ 'various'), əl-lóhke 'he does thus' (with /əl-/ 'thus'), təl-lóhke 'he is working' (with /ətəl-/ 'ongoing'), and wapəl-əlóhke 'he does wrong' (with /əwap l-/ 'improper').

The syllabified underlying form of míllóhke is (276), ignoring the third person suffix as usual.

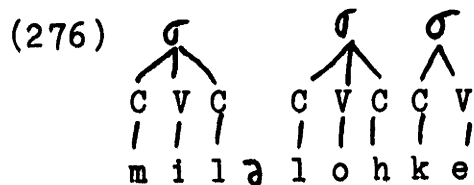

No rule of V-slot epenthesis is applicable here. The floating /ə/ of /-əlóhke-/ thus remains unassociated with a V position and is deleted by Schwa Deletion IV.

The syllabified underlying form of əllóhke is (277).

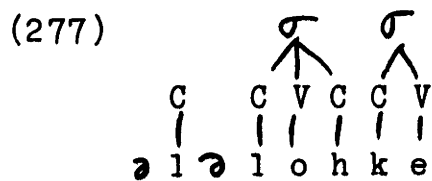

The /l/ of /əl-/ cannot be extrametrical here, since it follows a floating /ə/. As a sonorant in a word-initial sequence of the form / (C) ə [+sonorant] ə /, this segment triggers Initial Syllable Epenthesis, giving (278).

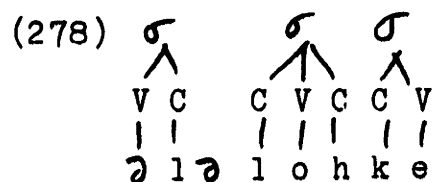

Again the /ə/ of /-əlóhke-/ remains unassociated with a V-slot and is subject to deletion.



In the underlying form of tʰəllohke, the leftmost C which cannot be syllabified is that associated with the /t/ of /təl-/, as shown in (279a). Initial Syllabic Epenthesis is not applicable, but V-Epenthesis is. The resulting structure is (279b).

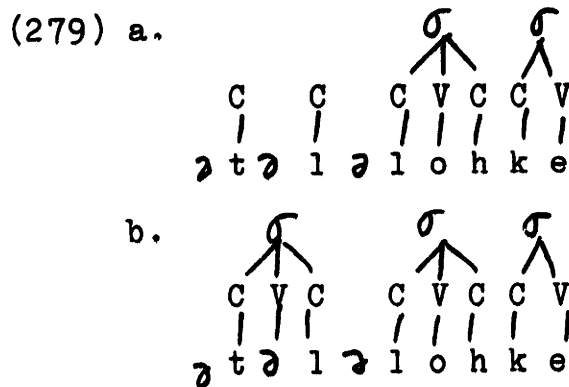

The first /ə/ of /təl-/ is now subject to Schwa Deletion I, while the /ə/ of /-lohke-/ is again deleted by Schwa Deletion IV.

The syllabified underlying form of wapəlohke is (280a). Once again V-Epenthesis is applicable, but this time it is the /ə/ of /-əlohke-/ which receives a V-slot, as shown in (280b).

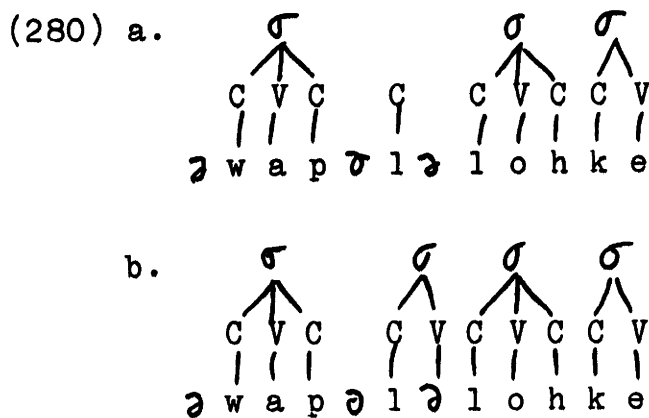

Neither of the unassociated schwas in (280b) is subject to Schwa Deletion I, since both are followed by sonorants. The initial

/ə/ of /əwapəl-/ is deleted by the rule for word-initial syncope, which will be formulated in 5.9. The /ə/ of /-əlohke-/ is not deleted by Schwa Deletion IV this time, since it is now associated with a V-slot. Schwa Support gives (281), as required.

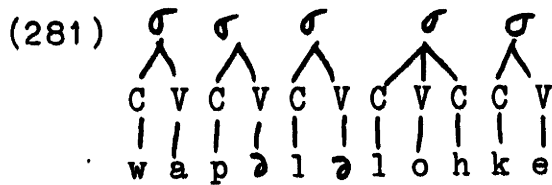

The derivations of étələlátək and étələlókhet are parallel to that of wápələlókhe, except for the loss of initial /ə/ in the latter. The derivations of ntətələlátəm and ktətələlókhepən, on the other hand, involve two applications of V-Epenthesis. The syllabified underlying form of ntətələlátəm is (282a). Final Syllable Epenthesis derives (282b).

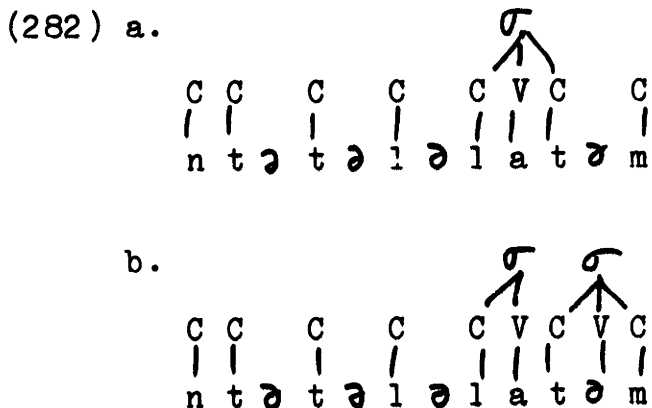

The /n/ of the prefix /nt-/ is not a possible trigger of V-Epenthesis, both because it is extrametrical and because it is not followed by a floating /ə/. The /t/ of the prefix is therefore the leftmost eligible C' in (282b). V-Epenthesis associates a V-slot with the /ə/ which follows this /t/, giving

(283a). The /t/ of /atəl-/ can be syllabified once a V-slot is inserted for the preceding /ə/, but the /l/ of this morpheme remains unsyllabified and triggers a second application of V-Epenthesis. In the resulting structure, the first /ə/ of /-atəm-/ is associated with a V-slot, as shown in (283b). No longer a floating vowel, this /ə/ escapes Schwa Deletion IV. The application of Schwa Support converts (283b) to (283c).

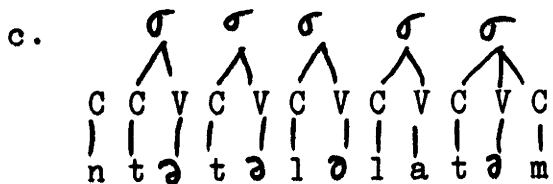
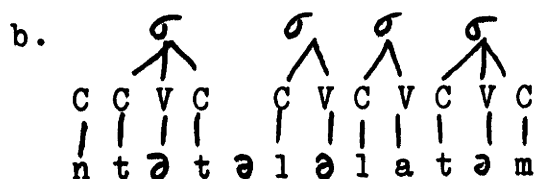
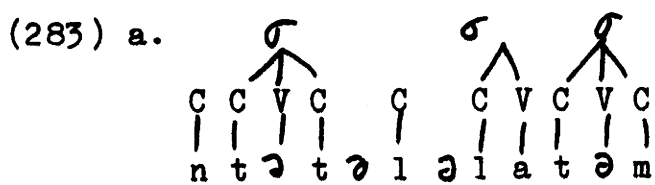

The interaction of Schwa Deletion IV with Final Syllable Epenthesis may be traced in the derivations of w-íləl (3-tongue) 'his tongue' and the corresponding locative form w-ill-ək. The syllabified underlying form of wiləl, given in (284a), is converted to (284b) by Final Syllable Epenthesis, preventing the deletion of /ə/ in this form by Schwa Deletion IV.

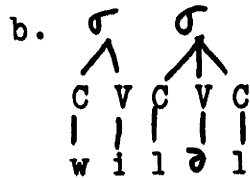
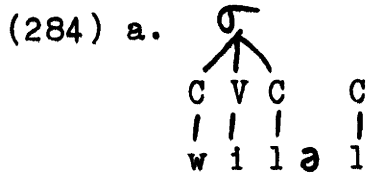

With the addition of a suffix in willək, the /ə/ of /-iləl/ no longer undergoes Final Syllable Epenthesis and Schwa Deletion IV is free to apply.

### 5.7.2 Deletion of /ə/ between obstruents

In many cases in which syncope results in a geminate consonant, the deletion can as plausibly be attributed to Schwa Deletion I as it can to Schwa Deletion IV. We have seen, for example, that the initial /ə/ of /-ətəmim-/ 'hire,' which surfaces after /sakh-/ 'into view' in h-sákh-ətəmím-a-l 'he appears, calls on the phone, etc. and hires the other,' is deleted by Schwa Deletion I after /ap-/ 'go and return' in ht-áp-təmím-a-l 'he goes somewhere and hires the other (and returns).' Thus there is no reason not to assume that Schwa Deletion I is responsible for the loss of /ə/ after /nat-/ 'come, go' and /pet-/ 'arrive' in nat-təmím-al 'he goes somewhere and hires the other' and h-pét-təmím-a-l 'he comes and hires the other.'

Evidence that Schwa Deletion IV must be allowed to delete /ə/ between obstruents as well as between sonorants comes from

exceptions to Schwa Deletion I. As I noted in 5.2.7, the morphemes /əpi-/ 'sit, be located,' /-ətəmi-/ 'cry,' and /-ətəkwwi-/ 'jump' do not usually lose their initial schwas to syncope. All three retain /ə/, for example, after /ehkw-/ 'stop' in (285). (The /h/ of /ehkw-/ is deleted in these forms by a rule which will be discussed in 5.8.2.)

- (285) a. ékw-əpo  
 stop-sit-(3)  
 'he stops sitting, stops being able to sit up'
- b. ékw-ətémo  
 stop-cry-(3)  
 'he stops crying'
- c. ékw-ətákkó  
 stop-jump-(3)  
 'he stops jumping'

These morphemes do undergo syncope, however, when the result is a geminate consonant:

- (286) a. cóp-po  
 ~ cówáp-po  
 into.water-sit-(3)  
 'he sits partway into the water'
- b. éwép-po  
 up-sit-(3)  
 'he sits up, he is located at a height'

- (287) a. mé<sup>́</sup>t-té<sup>́</sup>mo  
 finish-cry-(3)  
 'he stops crying'
- b. pé<sup>́</sup>t-té<sup>́</sup>mo  
 arrive-cry-(3)  
 'he comes crying'
- c. wí<sup>́</sup>t-té<sup>́</sup>mo  
 with-cry-(3)  
 'he cries with someone'
- (288) pá<sup>́</sup>sít-tá<sup>́</sup>kkó  
 over-jump-(3)  
 'he jumps over'

As before, only stressable /ə/ may be deleted. Thus the possibility of deletion varies with prefixation and Initial Change in the AI+0 stem /wət-ətemi-/ 'cry about':

- (289) a. ht-ə<sup>́</sup>temí<sup>́</sup>-n- l  
 from-cry-PEG-33IN  
 'he cries about them (in.)'
- b. ó<sup>́</sup>t-temí<sup>́</sup>-n- l  
 (3)-from-cry-PEG-33IN  
 'he cries about them (in.)'
- c. wé<sup>́</sup>t-té<sup>́</sup>mi-t  
 from-cry-3AN  
 'he is crying about it (Conjunct)'

The underlying form of (289a) is (290a). The extrametrical initial /w/ of this word does not trigger V-Epenthesis, but the following /t/ does, giving (290b).

(290) a.

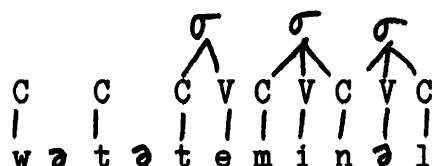

b.

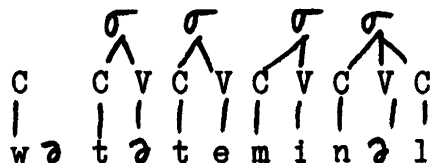

Schwa Deletion I eliminates the /ə/ of /wət-/ and the resulting cluster /wt/ is realized as ht as a result of Initial Devoicing. The /ə/ of /-ətəmi-/ is protected from syncope by the V-slot supplied for it by V-Epenthesis.

In (291a), the third person prefix is used. (Use of the prefix is optional but preferred for Independent Indicative forms of AI+0 verbs with third person subjects.) Because the /w/ of /wət-/ is not initial in this structure, it is not designated as extrametrical here. It therefore triggers V-Epenthesis, which turns (291a) into (291b).

(291) a.

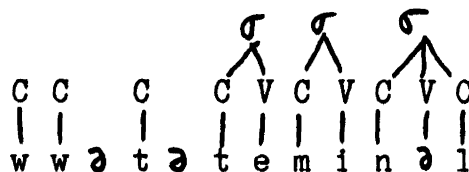

b.

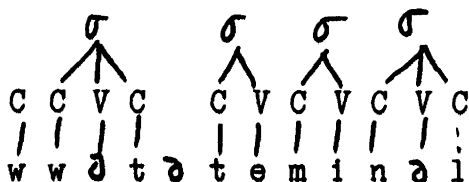

The /ə/ of /-ətəmi-/ is not associated with a V-slot, since the /t/ of /wət-/ is syllabified in (291b). Although this /ə/ is an exception to Schwa Deletion I, it is not an exception to Schwa Deletion IV, and is therefore deleted. Word-initial /wwə/ gives /wo/ by Contraction, ultimately surfacing as o through WO-Reduction. The result is óttémínəl.

Deletion also takes place in wéttémit, because Initial Change replaces the /ə/ of /wət-/ with the stressable vowel /e/:

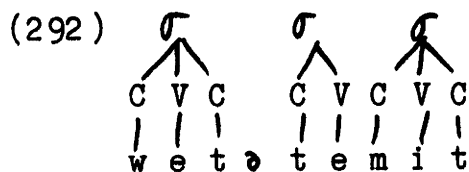

The derivations méttémo and the other examples in (286)-(288) are parallel to that of wéttémit, except for the effects of I-Mutation in underlying final /iw/.

### 5.7.3 Deletion in the environment of complex segments

Up to this point in our analysis of syncope, we have been able to ignore the internal structure of the complex segments /c/ and /kw/. This structure becomes significant, however, when we consider the way in which Schwa Deletion IV applies in the environment of these segments.

Schwa Deletion IV must be able to analyze /c/ as a unit, because schwas which are exceptions to Schwa Deletion I are nonetheless deleted between two occurrences of /c/. The initial schwas of /-əcəssi-/ AI and /-əcihte-/ II 'be a color' are



exceptions of the appropriate type. Neither is subject to Schwa Deletion I in (293), for example, although both are unstressable here:

- (293) a. əl-əcóssso  
 thus-color-(3)  
 'he is colored thus'
- b. míl-əcihté-t-ol  
 various-color-3-33IN  
 'they (in.) are of various colors'

The /ə/ of the root /məc-/ 'bad' is inherently stressable, as derivatives like məc-əw-e (bad-hair-AI-(3)) 'he has messy hair' and məci-hpók-ət (bad-taste-II-(3)) 'it tastes bad' attest. Thus the initial schwas of /-əcəssi-/ and /-əcihte-/ will remain unstressable in all forms of /məc-əcəssi-/ and /məc-əcihte-/ 'be a bad color.' As we see in (294), these schwas are subject to deletion. Since Schwa Deletion I is not applicable in these morphemes, Schwa Deletion IV must be responsible for these cases of syncope.

- (294) a. məc-cóssso  
 bad-color-(3)  
 'he is a bad color'
- b. məc-cíhte  
 bad-color-(3)  
 'it is a bad color'

Schwa Deletion IV must also be able to analyze /c/ as a sequence, because it deletes unstressable /ə/ between /t/ and

/c/. The roots /at-/ 'change' and /tot-/ 'to, at an extreme' end in /t/ in their basic forms, as we see in (295).

(295) a. at-óte

change-move-(3)

'he moves (changes residence)'

b. tót-əpo

extreme-sit-(3)

'he sits a long way off, he is far along'

When either of these roots is followed by /-əcəssi-/ or /-əcihte-/, /ə/ is deleted in the resulting sequence /təc/. This deletion can only be due to Schwa Deletion IV.

(296) a. ac-cəssó

change-color-(3)

'he changes color, he blushes'

b. tóc-cəssó

extreme-color-(3)

'he is dark'

(297) a. ac-cihté-t-ol

change-color-3-33IN

'they (in.) change color'

b. tóc-cíhte

extreme-color-(3)

'it is dark'

The cluster which results from syncope in these forms is written cc because it is phonetically identical with cc from /cəc/. In both cases, cc is a single affricate with a long stop component.

The preliminary statement of Schwa Deletion IV which was given as (275) is repeated here as (298).

(298) Schwa Deletion IV (preliminary)

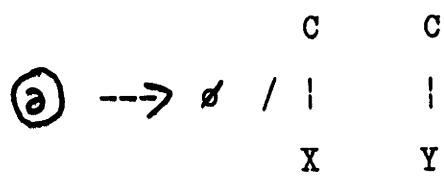

Condition: X = Y.

Given this formulation of Schwa Deletion IV and an analysis of /c/ as a sequence on the segmental tier, the deletion of /ə/ in (296) and (297) is predicted. Underlying tóccíhte, for example, we have (299). The identity condition of (298) is met by the segments labeled X and Y.

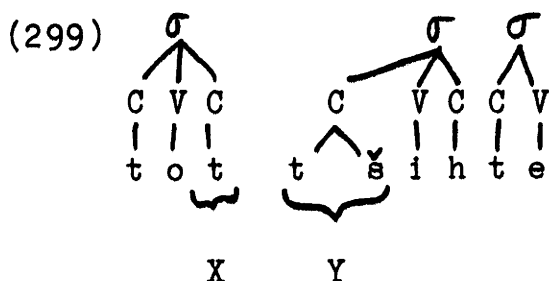

Of course the stop component of /c/ is not phonetically identical with t. It is, instead, homorganic with the fricative component of the affricate. There is nothing to prevent us from setting up /t/ as the first component of /c/ in phonological representations, however, and then accounting for the retracted

articulation of this stop in phonetic forms by a low-level rule of assimilation. In this way, the treatment of /təc/ sequences by Schwa Deletion IV is easily assimilated to the other cases of deletion which have been discussed above.

The analysis of /c/ as a sequence on the segmental tier leads to a further prediction about deletion in the environment of /c/. Since /ə/ is not flanked by identical segments in (300), we predict that Schwa Deletion IV will not apply in the sequence /cət/.

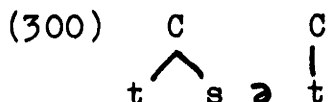

This prediction is borne out by derivatives of /məc-/ 'bad' made with the finals /-ətəmi-/ 'cry' and /-ətəkkwəwi-/ 'jump,' whose initial schwas have already been noted as exceptions to Schwa Deletion I. Schwa Deletion IV does not apply in (301) and underlying /c t/ is retained on the surface.

- (301) a. məc-ətəmo  
 bad-cry-(3)  
 'he (e.g. an actor) cries badly'
- b. məc-ətəkko  
 bad-jump-(3)  
 'he jumps badly'

These forms should be compared with kéc-tón-a-t 'in the corner of his mouth,' from /kəc-əton-a-t/ (edge-mouth-AI-3AN), where Schwa Deletion I applies regularly between /c/ and /t/.

Analyzing /c/ as a sequence on the segmental tier makes it possible to explain why Schwa Deletion IV is applicable in /təc/ but not in /cət/. But why is deletion possible in /cəc/? Given the sequential analysis of /c/, /ə/ is not flanked by identical elements of the segmental tier in (302).

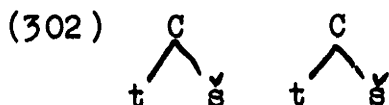

We can accommodate deletion in this structure without giving up our account of deletion between /t/ and /c/ if we interpret "X" and "Y" in the statement of Schwa Deletion IV as variables over strings rather than variables over single segments. Deletion is then possible in (303) because the floating /ə/ of /-əcihte-/ is flanked by identical strings of segments as indicated.

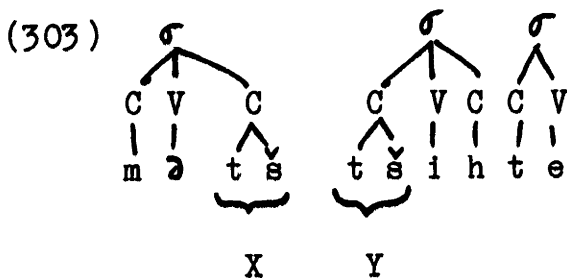

A revised statement of Schwa Deletion IV is given in (304).

(304) Schwa Deletion IV (first revision)

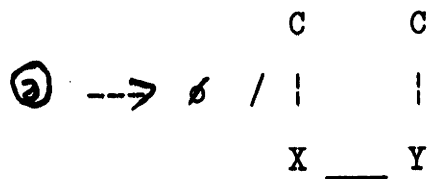

where X, Y are non-null strings of segments  
and X = Y.

In the intended interpretation, the notation (305a) represents any of the structures in (305b), where  $x_1, x_2, x_3$ , etc. are single segments (elements of the segmental tier).

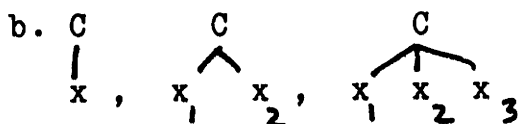
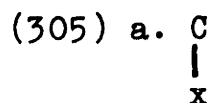

The restriction to non-null X and Y prevents the rule from deleting /ə/ between arbitrary C's. Requiring all of the segments in a string analyzed as X or Y to be associated with a single C prevents the rule from applying in a word like kís-əkíso (can-read-(3)) 'he can read,' where an unstressable /ə/ stands between identical strings of segments each of which is associated with more than one position on the CV tier.

While this revised statement of Schwa Deletion IV handles deletion in the environment of /c/, it is not adequate to account for all of the cases of deletion involving /kw/. If /kw/ has an internal structure comparable to that of /c/, we expect on the basis of (304) that deletion will take place between /k/ and /kw/

and between /kw/ and /kw/, but not between /kw/ and /k/. A possible case of deletion between /k/ and /kw/ will be discussed below. There seem to be no examples which allow us to test whether deletion is possible between /kw/ and /kw/. But two morphemes which begin with /ək/ are consistent exceptions to Schwa Deletion I, making it possible to test the prediction that Schwa Deletion IV will be blocked in /kwək/. The prediction is wrong in both cases.

The examples in (306) show that the initial schwas of /-əkəhkim-/ TA 'teach' and /-əkisi-/ AI 'read' are not subject to deletion by Schwa Deletion I. (See also the discussion of these morphemes in 5.2.7. The final /m/ of /-əkəhkim-/ is dropped before the reciprocal suffix in the impersonal construction illustrated in (306a) and (307a).) Yet the forms in (307) show that these schwas are subject to syncope after /ehkw-/ 'stop' (again reduced to ekw-). Clearly, then, Schwa Deletion IV is applicable to /ə/ between /kw/ and /k/. The cluster which results from deletion in such cases is phonetically realized as a long [k] with a labial release, which I interpret as a geminate kw.

- (306) a. mé-t-əkəhkí-ti-n  
 finish-teach-RECIP-UNSPEC  
 'school is over'
- b. mé-t-əkíso  
 finish-read-(3)  
 'he finishes reading'

- (307) a. ékw-kwéhkí-ti-n  
 stop-teach-RECIP-UNSPEC  
 'school is out'
- b. ékw-kwíso  
 stop-read-(3)  
 'he stops reading'

There are several ways in which we might try to accommodate these facts without further complicating our statement of Schwa Deletion IV. For example, we might analyze /kw/, at a suitably abstract level, as a /k/ on the segmental tier which is linked to an autosegmentally represented occurrence of [+round]. Then the sequence /kw k/ would simply be /k k/ on the segmental tier, and the application of Schwa Deletion IV in this sequence would be predicted:

(308) [+round]

c	c
k	k

Alternatively, we might suppose that /kwək/ is changed to /kwəkʷ/ or to /kəkʷ/ prior to the application of Schwa Deletion IV. In either event, the problematic applications of Schwa Deletion IV would reduce to cases of an expected type. I will argue below that the most viable of these proposals is the last: the metathesis of the /w/ component of /kw/ with a following /k/. Discussion of these alternatives is best postponed, however,



until we take up the question of the proper formalization of geminate formation.

#### 5.7.4 An additional rule of V-slot epenthesis

A further problem for the analysis of syncope between identical non-syllabics can be accounted for without complicating our statement of Schwa Deletion IV, but at the cost of postulating an additional rule of V-slot epenthesis.

In 5.2.1, I noted that Schwa Deletion I regularly applies before a consonant which surfaces in word-final position as a result of the application of Final Vowel Deletion. Deletion takes place, for example, in ímiye-w-p (pray-DA-liquid) 'holy water,' from /imiya-w-əpi/, because the floating /ə/ of /-əpi/ 'liquid' does not precede a word-final consonant at the point in the derivation when Final Syllable Epenthesis is applicable. This analysis of Schwa Deletion I requires that Final Syllable Epenthesis be ordered before Final Vowel Deletion.

Schwa Deletion IV appears to be optional or disfavored before a consonant which is left in word-final position by Final Vowel Deletion. The relevant environment arises only in a few morphemes, but one of these is /əpi-/ 'sit, be located.' The examples in (309) show that the /ə/ of this morpheme is an exception to Schwa Deletion I in forms that undergo Final Vowel Deletion, just as it is elsewhere.

- (309) a. n-mét-ə̀p  
 1-finish-sit  
 'I stop sitting up'
- b. n-téhsakw-ə̀p  
 1-on.top-sit  
 'I sit on top'
- c. kt-ékw-ə̀p  
 2-stop-sit  
 'you (sg.) stop sitting up'

When /ə̀pi-/ follows an initial ending in /p/, we expect Schwa Deletion IV to apply. In unsuffixed forms, however, syncope is optional or disfavored:

- (310) a. n-cówap-ə̀p  
 ~ ?n-cówap-p  
 1-into.water-sit  
 'I sit partway into the water'
- b. k-cówap-ə̀p  
 2-into.water-sit  
 'you (sg.) sit partway into the water'
- (311) a. éwep-ə̀p  
 up-sit  
 'sit (sg.) up, sit at a height!'
- b. kt-éwep-ə̀p  
 \*kt-éwep-p  
 2-up-sit  
 'you (sg.) sit up, sit at a height'

In comparable suffixed forms, where Final Vowel Deletion is not applicable, Schwa Deletion IV is obligatory and exceptionless: cówáp-po, \*cowap-əpo 'he sits partway into the water.'

It is easy to accommodate deletion by Schwa Deletion IV in forms like ncówápp, just as it is to accommodate deletion by Schwa Deletion I in ímiyéwp: Final Syllable Epenthesis precedes Final Vowel Deletion, therefore Final Syllable Epenthesis does not supply a V-slot for /ə/ in word-final /əpi/. What remains to be explained is why Schwa Deletion IV is blocked or disfavored in (310)-(311).

One way to accomplish this end is to postulate an additional rule of V-slot epenthesis which follows Final Vowel Deletion. The rule that we need, which I will call Geminate Epenthesis, is an analogue of Final Syllable Epenthesis, but will supply a V-slot for a /ə/ before a word-final C only if that /ə/ is flanked by identical segments:

(312) Geminate Epenthesis

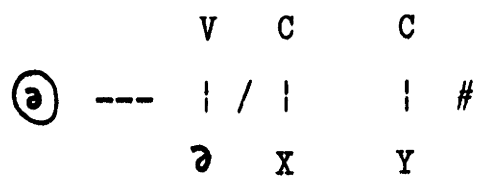

Condition: X = Y.

Alternatives to this statement are possible. In particular, it is not clear that the rule must mention the presence of the floating vowel for which it supplies a V-slot. Notice, however, that the rule as formulated is not applicable in words ending in an underlying geminate consonant, whether or not such clusters

are represented as underlying multiply linked structures. This is a correct result: underlying final geminates remain unchanged in words like tètt 'in that direction,' mówine-kk (bear-33ABS) 'bears (abs.),' and kt-éwep-atàkwkw (2-up-jump) 'you (sg.) jump up.' Geminate Epenthesis must be optional to account for variation like that in (310), but apparently application of the rule is favored.

Since Schwa Deletion IV must follow Geminate Epenthesis, it must also follow Final Vowel Deletion. Schwa Deletion I, on the other hand, need not follow either Geminate Epenthesis or Final Vowel Deletion. Of course both Schwa Deletion I and Schwa Deletion IV must follow the rules of V-slot epenthesis that were proposed in Chapter 4.

All of the forms of the verb 'vomit' can be derived from a stem /səkəkwi-/, provided that we assign this stem the CV structure shown in (313) and provided that both Schwa Deletion IV and Geminate Epenthesis are applicable to /ə/ between /k/ and /kw/. (We must also assume that the second /ə/ of /s k kw i-/ is an exception to Schwa Deletion I.) Several forms from the paradigm of this verb are given in (314).

(313) C V C            C V  
       | | |            / \ |  
       s ə k ə k      w i

(314) n-səkək̄kw ~ n-sək̄kwkw 'I vomit'

k-səkək̄kw ~ k-sək̄kwkw 'you (sg.) vomit'

sək̄kko 'he vomits'

n-səkkwí-pən

'we (du. exc.) vomit'

səkkwí-yàn

'when I vomited'

If Geminate Epenthesis is to apply in n-səkək and k-səkək, however, we will have to suppose that this rule can analyze the structure in (315) as shown and that the presence of an extra /w/ on the segmental tier does not prevent the second C in this structure from counting as word-final.

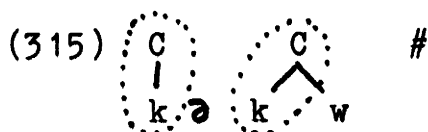

It is also possible, however, that /səkəkwi-/ has simply been reanalyzed as underlying /səkkwí-/, and that n-səkək and k-səkək are no longer phonologically derived from the same stem as other forms of this verb. These are, after all, the only forms (apart from the singular imperative) in which this stem would be unsuffixed and thus subject to Final Vowel Deletion. The fact that the syncopated forms n-səkkw and k-səkkw appear to be fully acceptable would seem to support this view.

A single example suggests that Geminate Epenthesis can apply between sonorant consonants as well as between obstruents and is therefore not applicable only to schwas which exceptionally fail to undergo Schwa Deletion I. The theme sign /-əl/, which indicates a second person object in various TA forms, regularly loses its /ə/ after /l/ by Schwa Deletion IV. (This /ə/ is probably epenthetic rather than underlying; see 7.2 for discussion.) Thus we have /-l/ for /-əl/ in forms like k-míl-l-əni-ya (2-give-2.OBJ-PEG-22) 'I give it to you (pl.).' Schwa

Deletion IV is blocked, however, in míl-əl 'that which I give to you (sg.),' which is derived by Final Vowel Deletion from /mil-əl-a/ (give-2.OBJ-1), where /-a/ is the word-final allomorph of the first person subject marker, non-final /-an-/. This apparent exception to Schwa Deletion IV is explained if Geminate Epenthesis is applicable in the derivation of míl-əl.

### 5.7.5 Geminate formation

Whether they are underlying or derived, geminate consonants in Passamaquoddy are phonetically realized as lengthened versions of the corresponding single consonants. There is no phonetic difference, for example, between the underlying tt of tétta 'in that direction' and the derived tt of mét-tákw-ət 'it stops making a sound' (from /meht-ihtakw-ət-w/ finish-sound-II-3) or between the underlying ss of wíss-ámk-ah-m-ǰni-ya ((3)-cover-particulate-TI-TI-3IN-33PROX) 'they cover it up with dirt) and the derived ss of h-kís-s-a-l 'he cut the other (with a knife)' (from /w-kis-əs-a-əl/ 3-past-cut-DIR-3.OBV).

Within the framework of CV phonology, long consonants have a natural representation as single elements of the segmental tier which are associated with two C positions on the CV or timing tier. Thus tétta and hkíssal may be represented as follows.

(316) a.  $\begin{array}{cccc} C & V & C & C & V \\ | & | & \diagdown & / & | \\ t & e & & & a \end{array}$

b.  $\begin{array}{ccccc} C & C & V & C & C & V & C \\ | & | & | & \diagdown & / & | & | \\ h & k & i & & & a & l \end{array}$

We may assume that non-derived geminate consonants like the tt of tétta are represented as multiply linked structures in underlying forms. Thus (316a) is the underlying representation of tétta. In the case of hkíssal, however, the output of Schwa Deletion I is presumably as shown in (317). (There should also be a derivation of hkíssal involving Schwa Deletion IV, since /-ʔs-/ 'by cutting edge' is an optional exception to Schwa Deletion I (see 5.2.7).)

(317)  $\begin{array}{cccccc} C & C & V & C & C & V & C \\ | & | & | & | & | & | & | \\ w & k & i & s & s & a & l \end{array}$

If (317) is converted into a surface representation like (316b), then there must be a process in the grammar of Passamaquoddy which turns sequences of identical non-syllabics into single long segments, as shown in (318).

(318)  $\begin{array}{ccc} C & C & C & C \\ | & | & \diagdown & / \\ \alpha_F & \alpha_F & & \alpha_F \end{array}$

The need for a rule with this effect is not as clear in the case of geminate glides as it is for geminate consonants: since there is typically no steady state in the pronunciation of geminate glides, representing them as sequences on the segmental tier





(320) a. Geminate Deletion (preliminary)

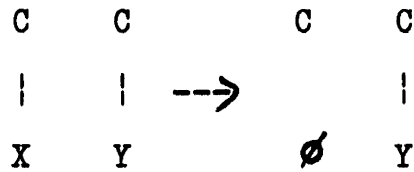

where X, Y are segments and X = Y.

b. Leftward Spreading

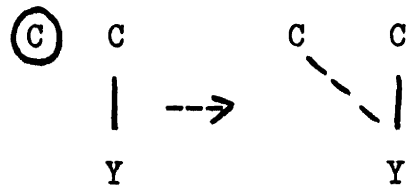

where Y is any segment.

The rules are adequate in this form to derive the correct surface representations of words like hkíssal 'he cut he other' or náttamímal 'he goes somewhere and hires the other' where geminate clusters of non-complex segments arise through the application of Schwa Deletion I. When we turn to cases involving complex segments, however, we encounter exactly the same problems that we ran into in trying to pin down the correct formulation of Schwa Deletion IV.

Underlying /cc/ and /kwkw/ are not common, but wíccickèp 'bandage' and póktéwicc 'liquor' (a variant of póktéwick) provide probable examples of basic /cc/ and méhci-kwkwí-ye (finish-bleed-go-(3)) 'he, it stops bleeding' and éwep-ə́təkwkwí-t (up-jump-3AN-(PERF)) 'when he jumped up' contain morphemes with non-derived /kwkw/.<sup>21</sup> Since it is only the stop components of cc and kwkw that are phonetically long, I assume that the geminate

clusters in these examples are represented as follows, both in underlying and in surface forms.

(321) a.  $cc = \begin{array}{c} C \quad C \\ \diagdown \quad / \\ t \quad s \end{array}$

b.  $kwkw = \begin{array}{c} C \quad C \\ \diagdown \quad / \\ k \quad w \end{array}$

Now surface cc may be derived either from /t/ plus /c/ or from /c/ plus /c/. Several examples showing the derivation of cc from each of these sources via Schwa Deletion IV were given in 5.7.3. An additional example of cc from /t/ plus /c/ is provided by the form h-kéc-cəpské-hl-a-l (3-out-root-TA-DIR-3.OBV) 'he uproots the other,' where ket- represents underlying /ket-/ 'out' (cf. h-két-ápité-hl-a-l (3-out-tooth-TA-DIR-3.OBV) 'he extracts the other's tooth'). Here again /ə/ is probably deleted by Schwa Deletion IV, since the medial /-əcəpske-/ 'root' corresponds to an independent noun wəcəpskw 'root' whose first /ə/ is an exception to Schwa Deletion I. The form məc-cək-e 'it is dirty,' from /məc-əcək-e-w/ (bad-messy-II-3), provides a clear example of cc derived from /cək/ by Schwa Deletion I, since the first /ə/ of /-əcək-/ undergoes this rule regularly, as we noted in 5.2.7.

Let us assume for the moment that geminate formation applies to the output of both Schwa Deletion I and Schwa Deletion IV. (We will have occasion below to revise this assumption with respect to Schwa Deletion IV.) Then the examples just cited show that geminate formation must be able to make both of the

following changes, since cc in both hkéccəpskéhlal and məccəke is phonetically identical with cc in wiccickèp and póktéwicc.

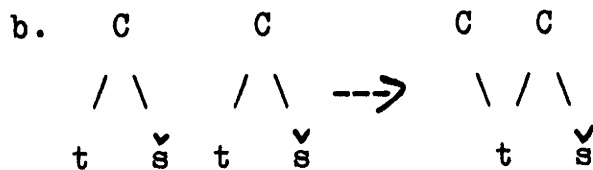
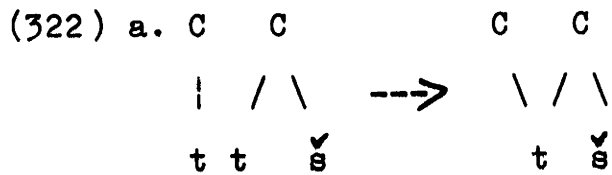

The change shown in (322a) can be effected by Geminate Deletion and Leftward Spreading as formulated in (320). With segments X and Y chosen as shown in (323), Geminate Deletion will eliminate X and Leftward Spreading will link Y to both C-slots, creating the desired multiply linked structure.

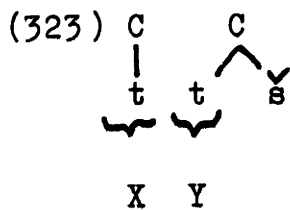

The change shown in (322b) cannot be carried out by the rules of (320), however, since the structure shown in (324) does not contain sequence of two identical units of the segmental tier.

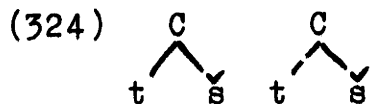

Once again we can obtain the results that we need by introducing string variables in place of variables over segments, this time in our formulation of Geminate Deletion:

(325) Geminate Deletion (first revision)

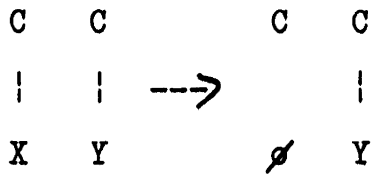

where X, Y are strings of segments and X = Y.

Geminate Deletion, thus formulated, will analyze (326a) as shown and convert this structure into (326b). The result is indistinguishable from the structure which Geminate Deletion derives from (323). Leftward Spreading will accordingly treat both structures alike, giving (326c) in both cases.

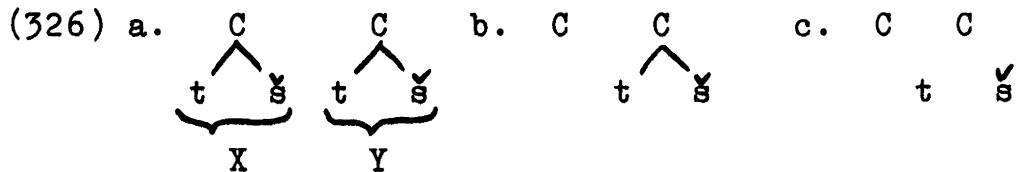

Note that the formulation of Geminate Deletion given in (325) correctly distinguishes /tc/ and /cc/, both of which surface as cc, from /ct/, which surfaces unchanged. Geminate Deletion is not applicable to a structure like that shown in (327), since no adjacent strings of identical segmental material are present.

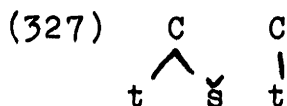

Relevant examples include kéc-tón-a-t 'in the corner of his mouth,' derived by Schwa Deletion I from /k~~e~~c-~~a~~ton-a-t/ (edge-mouth-AI-3AN), and the following forms which result from the

deletion of underlyingly unstressable /i/: mác-ták-w-ət 'it sounds bad' (from /mác-ihtakw-ət-w/ bad-sound-II-3) and cəc-té-hsən 'it hits against something' (from /cəc-ihte-hsən-w/ sudden(?)-strike-come.to.rest-3).

Like /c/, /kw/ raises the same problems for geminate formation as it does for Schwa Deletion IV. On the basis of our first revision of Geminate Deletion, we expect this rule to apply to a sequence of /k/ and /kw/ or to a sequence of /kw/ and /kw/, but not to /kw/ followed by /k/, since (328a) and (328b) contain sequences of identical strings of segmental material, but (323c) does not.

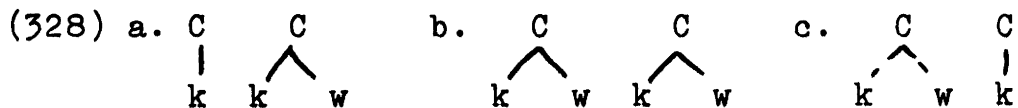

This prediction is incorrect, however, sequences of all three types undergo geminate formation in the same fashion, yielding kwkw, that is (329).

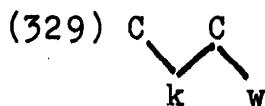

Cases of the expected types are only sparsely represented in my data, although I assume that this fact is accidental. The only possible examples of kwkw from /kw/ that I can cite are the forms nsəkkwk (~ nsəkək) 'I vomit' and ksəkkwk (~ ksəkək) 'you (sg.) vomit' which were discussed in 5.7.4. (As we noted there, geminate kwkw may have been reanalyzed as underlying in these forms.) The derivation of kwkw from /kw/ plus /kw/ is seen in ékw-kwé-po 'he stops being able to sit up,' underlying /ehkw-

ohkwe-pi-w/ (stop-body-sit-3); cf. sákh-ohkwé-po (into.view-body-sit-(3)) 'he sits, protruding into view.'

The problematic case is much better attested. I have already given two examples in connection with the discussion in 5.7.3 of the conditions which govern Schwa Deletion IV: ékw-kwehki-ti-n 'school is out' (from /ehkw-əkehki-ti-n/ stop-teach-RECIP-UNSPEC) and ékw-kwíso 'he stops reading' (from /ehkw-əkisi-w/ stop-read-3). The kwkw of ékw-kwa 'he stops dancing' (underlying /ehkw-əka-w/ stop-dance-(3)) is presumably derived via Schwa Deletion I, since /-əka-/ 'dance' appears to undergo this rule regularly in most combinations (see 5.2.7). Surface kwkw results from the deletion of /a/ in underlying /kwahk/ in éci wəli-nakw-kw-əs 'it looked very beautiful (dubit.),' from /eci wəli-nakw-ah-k-əs/ (very good-look-II-3IN-DUBIT); compare wəli-nakw-ə-k-s 'it looked good (dubit.),' with an alternative pattern of syncope. Syncope of /i/ gives kwkw from /kwihk/ in wikw-kwət 'the tide goes out,' from /wihkw-ihkət-w/ ((take(?)-ebb-(3)); compare ks-íhkət (intense-ebb-(3)) 'the tide is at its lowest (in its monthly cycle).' Syncope of /o/ in underlying /kwohk/ may be involved in the derivation of áhkíkw-kwe 'he hunts seals,' apparently from /ahkíkw-ohke-w/ (seal-acquire-3); compare típs-ohke 'he collects spruce tips,' with English tips. Compare also ətóhk 'deer,' kíyahkw 'seagull,' and ákətálahkw 'alligator' and their respective absentative obviative singulars ətók-kəl, kíyakw-kwəl, and ákətálahkw-kwəl.

In 5.7.3 I briefly introduced three possible ways to get around the fact that our proposed formulation of Schwa Deletion IV will not apply, as it must, in sequences of the forms /kwək/.

The same possibilities come up when we look for an explanation of the fact that geminate formation must be applicable, despite our formalization, to sequences of the form /kwk/.

First, we might propose that the labialization of /kw/ is autosegmentally represented in some fashion, say by linking to an occurrence of the feature [+round] on a separate tier. We would certainly expect geminate formation to apply to the structure shown in (330a).

(330) a. [+round]	b. [+round]
C   C	C   C
	\ /
k   k	k

The problem with this proposal is that the output of geminate formation will be (330b). Here the feature [+round] is linked to the first portion of a long /k/. But kwkw is characterized by a labial release. Either (331a) or (331b) would therefore be a more likely representation for kwkw if rounding is represented autosegmentally.

(331) a. [+round]	b. [+round]
/ \	
C   C	C   C
\ /	\ /
k	k

We might try to derive one of the structures in (331) from (330b), but this would render the autosegmental approach

essentially pointless: if we can find a way to induce labialization in a /k/ which follows /kw/, then we can account for the application of geminate formation to /kwk/ without recourse to autosegmental representations.

Suppose, then, that /k/ is rounded to /kw/ after /kw/. If we maintain our representation of /kw/ as a complex segment, there are two possibilities: a copying metathesis of /w/, as shown in (332a), or metathesis without leaving a copy, as shown in (332b).

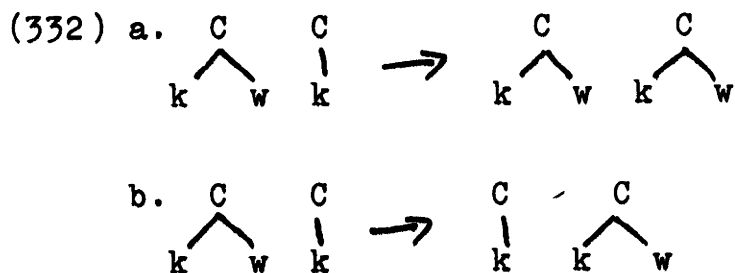

Either operation yields a structure to which Geminate Deletion as currently formulated will apply.

There does not appear to be any particular advantage to copying metathesis in this case, since the copy left behind will always be eliminated by Geminate Deletion. Let us therefore try to formalize the metathesis process shown in (332b). (This is essentially the proposal adopted for Maliseet by Sherwood (1983b:45), although he was not working within a CV framework.)

We do not simply want to say, in our formal statement, that a /w/ disappears on one side of /k/ and a /w/ appears on the other. After all, we could just as easily say, formally, that a /w/ disappears to the left of /k/ and a /t/ appears to its right. Somehow we want to say that a /w/ appears to the right of /k/



because a /w/ disappears on the left. To accomplish this end, our rule must have transformational power. Suppose, then, that we borrow the conventions of transformational notation and formalize metathesis as follows:

(333) Metathesis (preliminary)

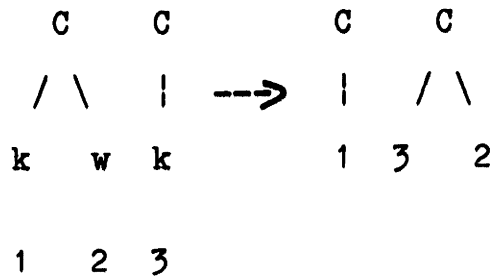

We will need to constrain this rule in some fashion so that it cannot perform the following operation, a metathesis of the /w/ component of /kw/ with the /k/ of a following /kw/:

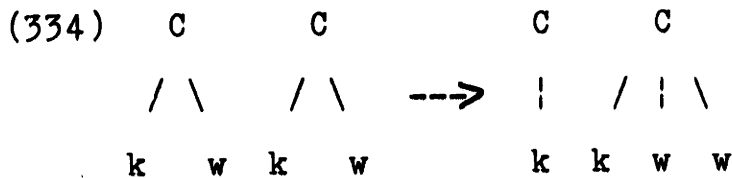

I will return to this matter in 5.7.7.

Rule (333) will solve the problem that we faced in trying to get Geminate Deletion to apply to the sequence /kwk/. A simple change in the statement of Metathesis will also permit this rule to shift the /w/ component of /kw/ rightward across an unstressable /ə/. In this way we can arrange for the application of Schwa Deletion IV as required in underlying /kwək/. All that we need to do is to add a parenthesized floating /ə/ to our statement of Metathesis:

(335) Metathesis (revised)

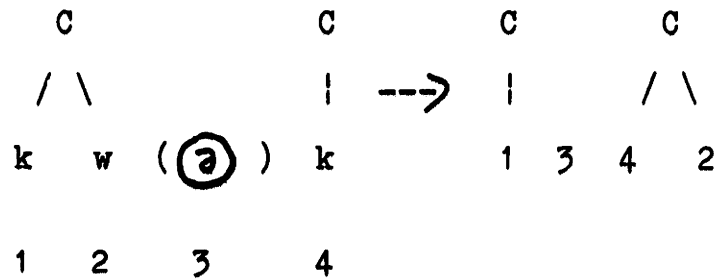

On the assumption that Schwa Deletion IV and Geminate Deletion are distinct rules, and that Metathesis is ordered before either of them, we may sketch the derivation of ékkwíso 'he stops reading' as follows. The underlying form /ehkw- kisi-w/ becomes (336) through the application of I-Mutation and Final Syllable Epenthesis.

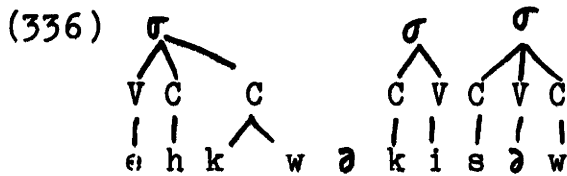

Metathesis converts (336) to (337a), which is then subject to Schwa Deletion IV, giving (337b).

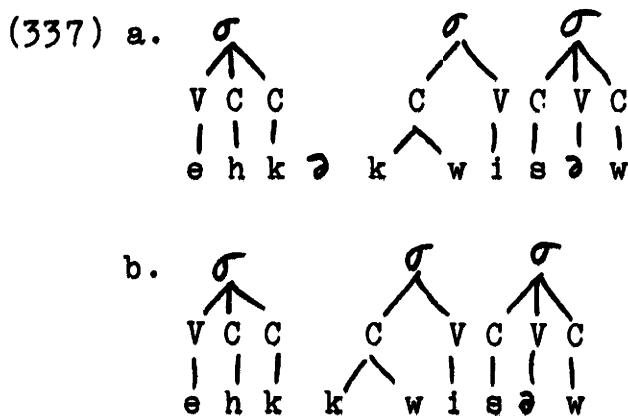

Geminate Deletion followed by Leftward Spreading gives (338a), which is converted to the surface form (338b) by the deletion of

/h/ before /CC/ (to be discussed in 5.8.1) and the replacement of word-final /əw/ by o.

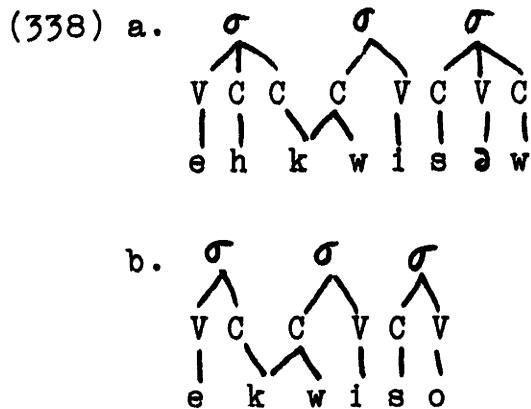

We now have a system that works, in the sense that it generates the right forms. The proposals above can hardly be claimed to have much explanatory force, however. Why does the metathesis of /w/ take place across an intervening segment? Why is /w/ subject to Metathesis only when it is a component of the complex segment /kw/? (Compare sákwamá-w-ka (chief-DA-dance-(3)) 'he does a governor's dance' or pkáte-w-kwí-w (smoke-DA-II-(3)) 'it is hazy,' where no metathesis takes place.) Note also that both Metathesis and Schwa Deletion IV apply only in sequences which are realized on the surface as geminate consonants. Neither of these rules has effects which can be observed independently of those of geminate formation.

I will take up the question of the interrelationship of Metathesis, Schwa Deletion IV, and Geminate Deletion in 5.7.7, after a discussion in the next subsection which is aimed at establishing the independence of Geminate Deletion and Leftward Spreading.

### 5.7.6 Leftward Spreading

It is only by separating Leftward Spreading from Geminate Deletion that we can give a simple account of geminate formation. Moreover, two less general processes by which long consonants are derived share with geminate formation the property that lengthening results from the deletion of the left member of a cluster.

The crucial cases for the analysis of geminate formation are those involving /c/ and /kw/. The fact that the lefthand component of /c/ or /kw/ is lengthened in geminates shows that deletion must take place to the left of one of these segments: leftward rather than rightward spreading is called for. Note further that what is deleted is not always identical to what spreads leftward. When (339a) is converted to (339b), both the /t/ and the /s/ associated with the lefthand C are deleted, but only the /t/ associated with the righthand C spreads leftward. Similarly, when (340a) is converted to (340b), both /k/ and /w/ are deleted on the left, but only the /k/ on the right spreads onto the C position made available by deletion.

(338) a.    C        C            b. C    C  
           / \     / \                \ / \  
           t  š  t  š                    t  š

(339) a.    C        C            b. C    C  
           / \     / \                \ / \  
           k  w  k  w                    k  w

Neither of these operations can be carried out by a rule like (341) which combines deletion and leftward spreading into a single operation, regardless of how we interpret the variables.

$$\begin{array}{cccc}
 (341) & C & C & C & C \\
 & | & | & \text{---}\rightarrow & \backslash / \\
 & X & Y & & Y
 \end{array}$$

where  $X = Y$ .

Formulating Geminate Deletion and Leftward Spreading as separate rules eliminates this problem.

In addition to this essentially formal argument for the independence of Leftward Spreading, it is possible to give an empirical argument on the basis of two processes of compensatory lengthening. One of these was introduced in 4.2, where we noted that /hs/ surfaces as ss after /a/. Consider, for example, álá-ssin 'he lies around,' where /i/ in underlying /ali-hsin-w/ (around-lie-(3)) is changed to /a/ by I-Backing. In 4.2.2 I proposed that (343a) is converted to (343b) by H-Deletion I, repeated here as (342).

(342) H-Deletion I

$$h \text{ ---}\rightarrow \phi / \quad a \quad \underline{\quad} \quad s$$

(343) a. V C V C C V C  
 | | | | | | |  
 a l ə h s i n

b. V C V C C V C  
 | | | | | | |  
 a l ə s i n

c. V C V C C V C  
 | | | | | | |  
 a l ə s i n

Given a rule of Leftward Spreading which is independent of Geminate Deletion, all that H-Deletion I has to accomplish is what is stated in (342); (343b) will be transformed into (343c) by Leftward Spreading. If we were not allowed to invoke Leftward Spreading here, we would have to complicate the statement of H-Deletion I by mentioning the CV tier and explicitly establishing a second association line for the /s/ which triggers deletion.

A second type of compensatory lengthening derives cc as an optional variant of sc. This process evidently reflects a recent innovation: the forms with cc are used by some Passamaquoddy speakers but rejected by others. I have recorded cc for sc most often in kiccəl 'and already,' a variant of the phrase kís cəl ('already' plus 'and, in addition'). We find cc for sc in a word-internal environment in pós-cək-pe ~ póc-cək-pe (wet-messy-liquid-(3)) 'he is soaking wet'; cf. pós-kəsən-e (wet-shoe-AI-(3)) 'he has wet shoes.' Again we can account for the presence of a long consonant in surface forms by postulating a deletion rule which operates on the segmental tier. In this case, deletion must be optional:

(344) s ----> ø / \_\_\_ t <sup>v</sup> s

This rule will delete /s/ in (345a), leaving an empty C position in (345b). This empty C is then filled by Leftward Spreading, resulting in the lengthening of the stop component of the following /c/, as shown in (344c).

(345) a. C V C C V C C V  
 | | | ^ | | | |  
 p o s t s ə k p e

b. C V C C V C C V  
 | | ^ | | | | |  
 p o t s ə k p e

c. C V C C V C C V  
 | | ^ | | | | |  
 p o t s ə k p e

As long as we can appeal to an independent rule of Leftward Spreading, we need not specify the lengthening of /c/ in our statement of (344).

### 5.7.7 Generalizing Geminate Deletion

I noted in 5.7.5 that neither Metathesis nor Schwa Deletion IV has effects which can be observed independently of those of Geminate Deletion: both rules apply only in structures which surface as geminates. My purpose in this section is to propose a simple explanation for this fact: both rules can be collapsed with Geminate Deletion.

Let us begin by comparing Geminate Deletion and Schwa Deletion IV. The most recently revised versions of these rules are repeated in (346).

(346) a. Geminate Deletion

$$\begin{array}{ccc} C & C & C & C \\ | & | & & | \\ X & Y & \emptyset & Y \end{array} \longrightarrow$$

where X, Y are strings of segments  
and X = Y.

b. Schwa Deletion IV

$$\textcircled{a} \longrightarrow \begin{array}{ccc} & C & C \\ \emptyset / & | & | \\ X & \text{---} & Y \end{array}$$

where X, Y are non-null strings of segments  
and X = Y.

Clearly these rules are formally quite similar. Their similarity becomes even more apparent, in fact if we rewrite Schwa Deletion IV in the format of Geminate Deletion, as shown in (347).



(347) Schwa Deletion IV

C	C		C	C
		--->		
X	ⓐ	Y	X	∅ Y

where X, Y are non-null strings of segments  
and X = Y.

By using parentheses we can state the two deletion operations of  
(346) in a single rule:

(348)	C		C		C	C
				--->		
	X	(ⓐ)	Y		∅ ∅	Y

where X, Y are non-null strings of segments  
and X = Y.

Note that (348) directly states that the first of two identical strings of segments is deleted whenever an intervening floating /ə/ is deleted. This is exactly right: Schwa Deletion IV applies only in structures in which Geminate Deletion applies.

Let us now compare (348) with Metathesis, repeated here as (349).

(349) Metathesis

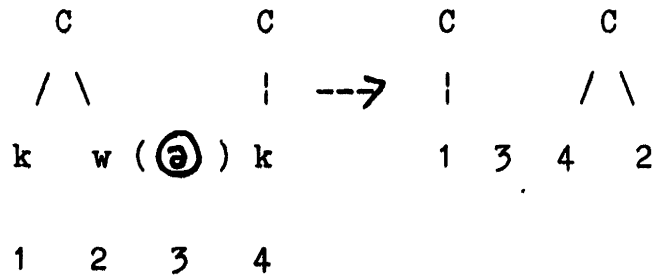

The occurrence of a floating /a/ in parentheses is a striking formal similarity between the two rules, and again they appear even more alike if we state them in the same format. A transformational statement of (348) is given in (350).

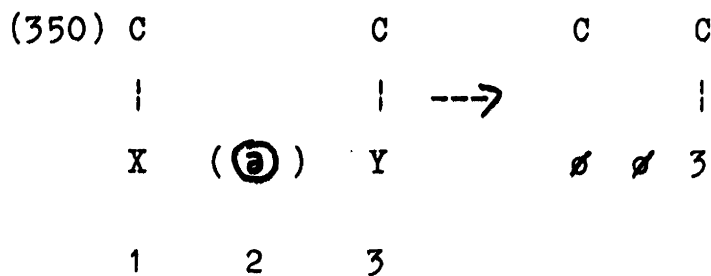

where X, Y are non-null strings of segments  
and  $X = Y$ .

Since we do not need to allow for any cases in which Metathesis applies but Schwa Deletion IV and Geminate Deletion do not, we can again collapse similar rules into a single formal statement:

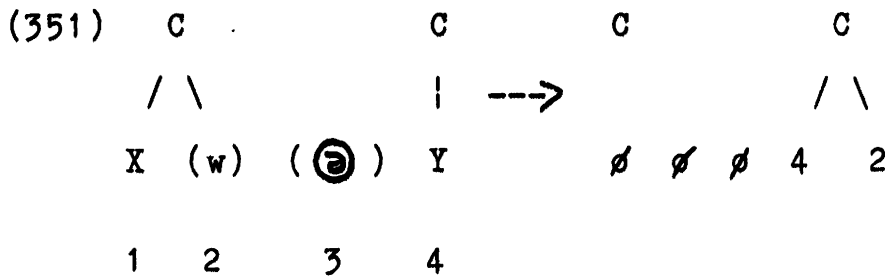

where X, Y are non-null strings of segments  
and  $X = Y$ .

Since /k/ is the only segment which occurs as the first component of a complex segment whose second member is /w/, it is not necessary to mention /k/ specifically in (351).

This combined rule still faces a problem which we noted in connection with our original formalization of Metathesis: it will incorrectly convert (352a) to (352b).

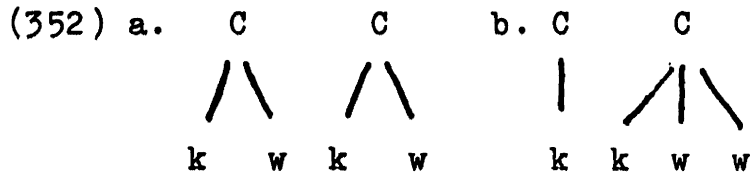

Now, however, there is a simple way to constrain our rule so that it will not have this consequence. The problem with the change shown in (352) is that we have not deleted everything associated with the lefthand C in the input structure which matches something associated with the righthand C: we need to maximize the deletion carried out by the rule. We can accomplish this end by adding a condition to the rule requiring that X be maximal: the /w/ component of /kw/ must be included in the string to be deleted if it may be.

### (353) Geminate Deletion

(final revision: incorporates Schwa Deletion IV  
and Metathesis)

C		C		C		C
/ \			-->		/ \	
X (w) (⊙) Y					∅ ∅ ∅ 4 2	
1 2 3 4						

where X, Y are non-null strings of segments,  
X = Y, and X is maximal.

Now (353) is surely much too cumbersome to be the correct formal statement of geminate formation in Passamaquoddy and the cases of syncope which accompany it. We may hope that a deeper understanding of the nature of geminate formation will make it possible to provide a more straightforward statement of this rule.

A combined statement of Metathesis, Schwa Deletion IV, and Geminate Deletion does, however, have the virtue that it answers several of the questions which have been raised in the course of this discussion. Why does the metathesis of /w/ seem to take place across an intervening segment? Because the rule which effects metathesis in fact deletes that segment. Why is /w/ subject to metathesis only when it is a component of the complex segment /kw/? Because /kwk/ is subject to geminate formation but /wk/ is not. Finally, why do Metathesis and Schwa Deletion IV have no effects which can be observed apart from geminate

formation? Because both of these operations are part of geminate formation. Given the explanatory power of such a combined statement, it seems reasonable to conclude that Schwa Deletion IV is not a rule in itself, but simply a reflection of a more general process by which geminate structures are derived.

### 5.8 Two rules deleting /h/

Two rules deleting /h/ which have been assumed but not formalized in previous sections are discussed here. The first rule removes /h/ before two consonants. In practice, these are either two obstruents or an obstruent followed by /h/. The second rule deletes /h/ before a single consonant, again always an obstruent, which is followed by an unstressable /ə/ and another obstruent. This rule is of interest because it provides evidence that the stressable/unstressable distinction is relevant to aspects of the phonological system of Passamaquoddy apart from stress assignment and syncope.

Despite the formal similarity of these two rules, it appears to be best not to collapse them. The first is obligatory and exceptionless, while the second appears to be sporadically optional and to have some outright exceptions. The two rules thus seem to be different in character.

#### 5.8.1 H-Deletion III

Underlying /h/ is deleted when it comes to stand before two consonants as a result of syncope or through the deletion of /e/

in the morphological derivation of explicitly plural AI and TI stems. (Sherwood (1983:21-22) has proposed that syncope is involved in the latter process as well.) The rule which deletes /h/ before clusters may be stated as follows:

(354) H-Deletion III

$$\begin{array}{c} C \\ | \quad \rightarrow \quad \emptyset / \quad \_ \quad C \quad C \\ h \end{array}$$

In all of the /hCC/ clusters which occur in the input to H-Deletion III, either both C's are obstruents or the first is an obstruent and the second is /h/. (This restriction is due to the fact that syncope does not take place after clusters of /h/ and sonorant.)

Alternations produced by H-Deletion III can be observed in the morphemes /-ahkw/ 'wood' and /-aht~~ə~~kw/ 'stick,' which function both as medials and as noun finals. The full forms are illustrated in (355) and (356).

(355) a. káhk-ákəm-ahkw

brittle-snowshoe-wood

'brittle white ash'

b. píht-ahkw-ət

long-wood-II-(3)

'it is long and stick-like'

c. kín-áhkwí-səməw-e  
large-wood-horn-AI-(3)  
'he has big antlers'

(356) tóhpiy-áhtəkw  
alder-stick  
'alder pole'

In (357), the morphemes /-ahte-/ 'be located,' /-əsi-/ (an AI final), and /-ihte-/ 'strike' occur in positions in which their initial vowels are not subject to syncope. In (358) these morphemes lose their initial vowels after /-ahkw-/ and the /h/ of /-ahkw-/ drops by H-Deletion III.

(357) a. sakh-áhte  
into.view-located-(3)  
'it protrudes into view'

b. piht-atək-əso  
long-line-AI-(3)  
'he is long (lying down)'

c. ks-atək-ihte'-hsin  
intense-line-strike-lie-(3)  
'it (an., string-like) strikes or pounds  
against something'

- (358) a. pəm-ákw-te  
 along-wood-located-(3)  
 'it (stick-like) lies there'
- b. piht-ákw-so  
 long-wood-AI-(3)  
 'it (an.) is long and stick-like'
- c. áŋkɔw-ákw-ti-hí-kən  
 further-wood-strike-TA-NOM  
 'second length of pounding ash from one tree'

In (359), where the /ə/ of /-ahtəkɔw/ is not the last vowel in a word, Schwa Deletion I is applicable, so /h/ is again left in a position where it subject to H-Deletion III.

- (359) a. tóhpiy-átk-ol  
 alder-stick-33IN  
 'alder poles'
- b. wəl-átkw-ənək-əso  
 good-stick-?-AI-(3)  
 'it (an.) is a tree with a good shape'

A number of nouns have singulars ending in /hsək/ but lose the /ə/ in this sequence to syncope in suffixed forms and then dro /h/ by H-Deletion III. These are all II diminutive participles in origin, but some of them either have more specialized meanings than the corresponding verb or no longer correspond to any verb at all. Several examples of this type are shown in (360), first without a suffix and then with the inanimate plural ending /-il/.



(360) péhsəwəhsəwéhs k 'flower'      péhsəwəhsəwésk-il  
 (cf. pskwáhsəwe      (pl.)  
 'it blooms')

pékkiktéhsək 'potato slice      pékkiktésk-il  
 cooked on stove top' (cf.      (pl.)  
 pkikte 'it is scorched,  
 burned)

péskətéhsək 'firecracker,      péskátésk-il  
 bean' (cf. péskáte 'it      (pl.)  
 shoots off, explodes')

pəssiyantéhsək 'window'      pəssiyantésk-il  
 (no corresponding verb)      (pl.)

Nouns stems which end in /hC/ lose the /h/ to H-Deletion III before the diminutive suffix /-hs/. (Epenthetic /ə/ is inserted in this environment and then dropped again; see 4.2.1 for discussion.) Several examples of this kind are given in (361). Unaffixed nouns are on the left, the corresponding diminutives on the right.

(361) təléhp 'playing card'      təlép-s-is 'club (card)'  
 álohk 'cloud'      álok-s-is  
 ətóhk 'deer'      ətok-s-is

ákətálahkw 'alligator'	ákətalákw-s-is
cáhahkw 'butt of a tree'	cáhákw-s-is
pkwáhkw 'grassy former bog'	pkwákw-s-is

Explicitly plural AI stems are made from AI stems ending in /e/ by dropping this /e/ and adding /-həti-/: wík-hí-ke (draw-TA-AI-(3)) 'he draws, writes, etc.'; wík-hi-k-hətə-w-ək (draw-TA-AI-PL-3-33PROX) 'they (pl.) draw, write, etc.' When the base of this formation is a stem ending in /hCe/, H-Deletion III eliminates the first /h/ in the cluster /hCh/ which results from the deletion of /e/: kíhke (plant-(3)) 'he plants,' kík-hətə-w-ək (plant-PL-3-33PROX) 'they (pl.) plant.' The TI stem /-əwehke-/ 'use' forms explicit plurals on the same pattern: ht-ówéhka-n (3-use-3IN) 'he uses it,' ht-ówék-hətí-ni-ya (3-use-PL-3IN-33PROX) 'they (pl.) use it.'<sup>22</sup> Some additional AI examples are given in (362). Third person singular forms are on the left, third person plurals on the right'

(362) tóh-pe	tóp-hətə-w-ək
'it (an.) contains liquid'	
átkóhke	átkok-hətə-w-ək
'he tells an old story'	
l-áhke	l-ak-hətə-w-ək
'he throws, drops'	

lóhke

'he works'

lók-hátə-w-ək

mósó-hke

'he hunts moose'

mós-ok-hátə-w-ək

séhke

'he stands'

sék-hátə-w-ək

wetí-hke

'he has intestinal worms'

wéti-k-hátə-w-ək

sóksáhke

'he cooks'

sóksakw-hátə-w-ək

H-Deletion III is applicable in a variety of other contexts as well. A few examples of the loss of /h/ in the root /ehkw-/'stop' are given in (363). Comparable examples could be given for a dozen other roots.

(363) a. éhkw-amkéle 'it stops burning'

éhkwi-nto 'he stops singing'

b. ékw-hí-ke 'he stops shooting'

ékw-kwa 'he stops dancing'

ékw-tákw-so 'he stops talking'

ékw-ti-hí-ke 'he stops knocking, pounding, etc.'

ékw-tək-ət 'it ends (said of a length)'

Examples of the deletion of /h/ in diminutives of álohk 'cloud' and ətóhk 'deer' were given in (361). Deletion in these stems is clearly not tied to this morphological context, however, as we

can see from forms like pam-álok-te (along-cloud-located-(3)) 'there is a stretch of cloud,' ətók-ke 'deer-acquire-(3)) 'he hunts deer,' and ətók-kəl (deer-3.OBV.ABS) 'deer (obv. abs. sg.).'

A subset of the Passamaquoddy speakers for whom iyi may be replaced by ihi (as discussed in 3.4) also reduce some occurrences of ihi to hi. This reduction sometimes produces clusters of the form hCh, but these clusters are not subject to H-Deletion III. Some typical examples are given in (364). All of these forms were obtained from a single speaker (A.H.).<sup>23</sup>

- (364) a. sahti-yil  
       ~ sahti-hil  
       saht-hil  
       blueberry-33IN  
       'blueberries'
- b. tóhpi-hil  
       ~ tóhp-hil  
       alder-33IN  
       'alders'
- c. élohki-yin  
       work-2  
       'you (sg.) work (Conjunct)'
- i. ətəl-əlóhk-hin  
       ongoing-work-2  
       'you (sg.) are working (Conjunct)'

These surface occurrences of hCh are easily explained if the reduction process which they reflect is ordered after H-Deletion

III. With these cases accounted for, H-Deletion III appears to be exceptionless.

### 5.8.2 H-Deletion IV

A relatively small number of verb stems undergo a rule which deletes /h/ in morheme-final /hC/ before a final or medial which begins with an unstressable /ə/ followed by an obstruent. Since only a small number of morphemes are potential triggers, it is difficult to exclude the possibility that this rule is morphologically governed; but it appears to be possible to give it a general phonological formulation as follows:

#### (365) H-Deletion IV

$$\begin{array}{ccc}
 C & & C & & C \\
 | & \text{---}\rightarrow & \emptyset / \text{---} & | & | \\
 h & & X \textcircled{a} & [-\text{sonorant}] & 
 \end{array}$$

The variable X is required in order to state the relative positions of the associated C and the floating /ə/. X must be allowed to range over strings of segments, since /kw/ may occur in this position.

For the application of H-Deletion IV to be detectable, the /ə/ in the environment of the rule must not be subject to syncope. Otherwise underlying /hC C/ will become /hCC/ and /h/ will be lost in any case by H-Deletion III. Since unstressable /ə/ is regularly subject to syncope before obstruents, it follows that the /ə/ in the environment of H-Deletion IV must be an

exception to Schwa Deletion I in any form in which the application of the rule can be detected on the surface. I have identified six finals and one medial which begin with exceptional schwas and which trigger H-Deletion IV: the finals /-əci-/ 'be cold,' /-əpi-/ 'sit,' /-ətemi-/ 'cry,' /-ətəkkwki-/ 'jump,' /-əkehki(m)-/ 'teach,' and /-əkisi-/ 'read' and the medial /-əkisk-/ 'day.'

Deletion of /h/ by H-Deletion IV is attested in the following eleven roots:

- (366) amihk- 'up'
- cohp- 'into water'
- cowahp- 'into water'
- ehkw- 'stop'
- kehs- 'X much, X many'
- mehs- 'why, (what) for'
- meht- 'stop, finish'
- sahs- 'quickly'
- sehs- 'to tears'
- tehsahkw- 'on top'
- tohk- 'awaken'

The medial /-ahkw-/ 'wood' also alternates in this fashion. (Etymologically, /tehsahkw-/ consists of \*/tehs-/ 'on top' plus /-ahkw-/ 'wood,' but synchronically /tehsahkw-/ appears to be unanalyzable.) Examples of the full forms of the roots are given in (367). (All of the examples are Independent Indicative forms except (e). Verbs forms with /mehs-/ 'why' are used only with Conjunct inflection.) For /-ahkw-/, see (355) above.)

- (367) a. ámihk-éssó  
 up-move-(3)  
 'he gets up (from sitting)'
- b. cóhpí-ye  
 ~ cówahpí-ye  
 into.water-go-(3)  
 'he, it goes, falls into the water'
- c. éhkw-əlóhke  
 stop-work-(3)  
 'he stops working'
- d. kéhs-əlóhke  
 X.much-work-(3)  
 'he works such-and-such an amount'
- e. méhsí-hpi-t  
 why-eat-3AN  
 'why is he eating?'
- f. méht-əlóhke  
 finish-work-(3)  
 'he gets off work, stops working'
- g. sáhs-éssó  
 quickly-move-(3)  
 'it goes back and forth quickly'
- h. séhs-əlóhke  
 to.tears-work-(3)  
 'he works so hard that he is ready to cry'
- i. téhsáhk-əlóhke  
 on.top-work-(3)  
 'he works on a desk, table, etc.'

j. tóhkí-ye  
 awaken-go-(3)  
 'he wakes up'

The attested combinations of roots and finals in which H-Deletion IV is applicable are shown in (368). The semantics of these stems is fairly transparent, with the exception of /sahs-ətemi-/ 'cry.' Here there is no apparent semantic contribution of the root /sahs-/ 'quickly,' so that a synchronic analysis of this stem must be considered doubtful. Note that H-Deletion IV is only applicable (or in any event only detectable) in unsuffixed forms of /cowahp-əpi-/ 'sit partway into the water,' since Schwa Deletion IV (Geminate Deletion) always turns /pəp/ into /pp/ in suffixed forms of this stem. (See 5.7.4 for details.)

(368) a. tók-əco 'he wakes up cold'

b. k-cówap-əp 'you (sg.) sit partway  
 into the water'

ékw-əpo 'he stops being able to sit up'

kés-əpí-hin 'because you (sg.) were  
 sitting for so long'

met-əpo 'he is through sitting down;  
 it (an.) ends there'

téhsákw-əpo 'he sits on top of something'





The explicit restriction of H-Deletion IV to contexts in which the second C in /hCəC/ is an obstruent is required by examples like éhkw-əlóhke, méht-əlóhke, and séhs-əlóhke, cited above, and many others: kísi éhkw-əlatə-k (past stop-breathe-3AN-(PERF)) 'when he had stopped breathing,' séhs-əm-áhti-t (to.tears-by.mouth-DIR-33PROX-3) 'they cause the other to cry by biting him (Conjunct),' méht-əno (finish-II-(3)) 'it is all gone,' méht-əwé-he (finish-hair-go-(3)) 'his hair is falling out.'

By requiring a floating /ə/ in the environment of H-Deletion IV, we will correctly prevent the rule from applying in forms like ks-íhpəte (intense hot-(3)) 'it is very hot' and nəmíhkwəso (be.born-(3)) 'he is born' in which /ə/ is lexically specified as stressable. Cases of this kind also make it clear that an unstressable /ə/ and not merely an unstressed /ə/ is required for deletion. The /h/ of míhkwətəkən 'knife' is retained, for example, even though /ə/ is unstressed here in the sequence /hkwət/, because this /ə/ is inherently stressable, as we can see from the absentative form míhkwətəkən. Similarly, /h/ is not deleted before /kw/ in nəmíhkwəsi-t-pən (be born-3AN-PRET) 'when he was born' because the following /ə/ is stressable.

If we assume that H-Deletion IV follows Final Syllable Epenthesis, then /h/ will also be retained as required in forms like tóhpiy-áhtək 'alder pole' and pəsiyantéhsək 'window,' since /ə/ in word-final /hC C/ will have been provided with a V-slot by the time H-Deletion IV is applicable. If we further assume that H-Deletion IV follows S-HS Epenthesis, then the deletion of /h/ will correctly be blocked in diminutives like

pil-éya-hs-əss-is (new-NF-DIM-DIM-DIM) 'new baby' and  
pilskwehs-əss-is (girl-DIM-DIM) 'little girl,' since epenthetic  
 /ə/ in intermediate /hs-əhs/ always receives a V-slot by this  
 rule.

H-Deletion IV does not apply in derivatives of /-hsəmi-/  
 'drink' or /-hsin-/ 'lie' such as éhkwá-ssəmo (stop-drink-(3))  
 'he stops drinking' or h-téhsákwə-ssín-oltí-ni-ya (30cn.top-lie-  
 PL-PEG-33PROX) 'they (pl.) lie on to of it.' Here again the  
 proposed formulation of H-Deletion IV has the right consequences.  
 The ə of surface əss in these forms is stressable, since it is  
 derived from connective /i/ by I-Backing in /i-hs/.

The application of H-Deletion IV could be prevented in some  
 of these forms even if we did not specify that /ə/ in the  
 triggering environment must be unstressable. A number of cases  
 in which deletion must be blocked could be excluded by requiring  
 that strings which undergo the rule must be of the form /hC+ C/,  
 since no morpheme boundary can be motivated (at least  
 synchronically) in the specified location in forms like  
námihkwáso, míhkwətákən, and tóhpiyáhtək. (An example like  
péskətéhsək 'firecracker' might still be a problem, if this is  
 synchronically derived from /peskəte-hs-ən-k/ (explode-DIM-  
 II-3IN).) Deletion will be blocked in éhkwá-ssəmo and the like  
 if it is possible to order H-Deletion IV before I-Backing. The  
 rule would have to be ordered very early indeed, however, to keep  
 it from being triggered by the epenthetic /ə/ of diminutives like  
pilskwehs-əss-is.

Moreover, even if a formulation of H-Deletion IV and an  
 ordering for the rule could be worked out which would handle all

of the problematic cases, this approach would still fail to provide an explanatory account. The fact is that there are simply no cases of an alternation that we would want to attribute to H-Deletion IV where /ə/ in the environment which triggers deletion counts as stressable. This generalization is expressed straightforwardly in the proposed formulation of the rule.

If V-Epenthesis applies first, then H-Deletion IV as stated in (12) will correctly be prevented from deleting /h/ before /l/ in forms like ác-ehl-əso (change-TA-REFLEX-(3)) 'he changes himself,' since V-Epenthesis provides a V-slot for any floating /ə/ which follows /hl/. It is thus unnecessary to specify in our statement of H-Deletion IV that the first consonant in the environment in which the rule applies is always an obstruent. To build this condition into the rule would in any case require some special provision to permit deletion after /kw/, if we assume that /kw/ is represented as a sequence of /k/ and /w/ in the segmental tier, since /w/ is a sonorant.

Although H-Deletion IV appears to be fairly regular within its restricted domain, there are several morphemes in which deletion appears to be optional (at least in the situation of elicitation). Two of my consultants (D.F. and A.H.) agreed in accepting both éhk-w-əpo and ékw-əpo (stop-sit-(3)) 'he stops being able to sit up' but rejecting \*méht-əpo as an alternative to mét-əpo (finish-sit-(3)) 'he finishes sitting down.' While sáhs-əkíso is apparently an acceptable alternative to sás-əkíso (quickly-read-(3)) 'he reads quickly,' \*séhs-əkíso was rejected (by D.F.) in favor of sés-əkíso (to.tears-read-(3)) 'he reads

until he cries.' In some cases I have received contradictory judgments from the same speaker on different occasions.

There also appear to be a few outright exceptions to the rule. The /h/ of the medial /-ahk-/ 'buttocks' (presumably related in some fashion to /-ahkohk/, the possessed stem of kohk 'buttocks') seems to be maintained consistently in forms like é<sup>1</sup>l<sup>0</sup>m-áhk-əpi-t (away-buttocks-sit-3AN) 'he is sitting with only his buttocks showing (Conjunct).' H-Deletion IV apparently does not apply to the stem of alohk 'cloud' when this is followed by the unstressable /ə/ of the II final /-ət-/ in má te álohk-ət-ò (not EMPH cloud-II-(3)-NEG) 'it is not cloudy.'

While H-Deletion III appears to be consistently obligatory and exceptionless, H-Deletion IV is neither. Thus it seems best not to attempt to collapse these two rules, despite their formal similarities.

### 5.9 Deletion of word-initial /ə/

One environment in which /ə/ is subject to syncope remains to be discussed: word-initial position. Here syncope takes place both before obstruents and before sonorants. If deletion of initial /ə/ before obstruents were limited to morphemes which undergo Schwa Deletion I, then we would only need a rule to account for the cases in which deletion takes place before sonorants. As it turns out, however, some schwas which are consistent exceptions to Schwa Deletion I nonetheless undergo syncope in word-initial position.

Now in analyzing other processes of syncope in Passamaquoddy, we have made crucial use of the assumption that

word-initial unsyllabified C is extrametrical. For example, in deriving ktákw-əno 'he stays over' from /kətək-w-əni-w/, we have assumed that the first /ə/ of /kətək-w-/ 'over' is subject to syncope because the unsyllabified initial /k/ of this root is extrametrical in this form when V-Epenthesis is applicable, so that it is not available to trigger the rule (see the discussion of this word in 5.2.10). In this way, we were able to permit syncope after word-initial consonants while preventing syncope after clusters.

But designating initial unsyllabified C as extrametrical creates a potential problem for the analysis of word-initial syncope. To account for the deletion of word-initial /ə/, we need to be able to make a distinction between schwas which actually begin a word and those which follow a word-initial unsyllabified C: only the former are subject to rule in question. How can we prevent our rule from deleting /ə/ after an initial C if this C has been designated as extrametrical and is therefore invisible to phonological rules?

A solution to this problem is available if we take into account the domain within which the rule in question is applicable. We have supposed that initial unsyllabified C is extrametrical on the domain word. Since extrametricality is tied to particular domains, designating a segment as extrametrical at the word level does not make it extrametrical within a larger domain. Thus a segment which cannot be analyzed by a word-level rule will nonetheless be available to rules which apply at the phrase level. If we assign the rule for word-initial syncope to the phrase level, we can restrict its application appropriately

without contradicting the assumptions about extrametricality which we have made in preceding sections.

Syncope in initial position, like the other syncope processes that we have looked at, affects only unstressable /ə/. We can state this restriction for initial syncope, as we have for our other syncope rules, by formulating a rule which applies only to unassociated schwas. The rule might then be stated as follows:

(370) Schwa Deletion V

⊙ → ø / # \_

Another formulation is possible in this case, however, which was not an option for the analysis of syncope in other environments. On the assumptions of the CV theory of stressability, a stressable vowel in a medial syllable may be stressed or unstressed, depending on its position in the syllable count from the end of the word. A stressable vowel in an initial syllable, however, will always be stressed, since the grammar of Passamaquoddy clearly contains a provision with the effect of the Initial Stress Rule of 4.1. In initial position, then, only an unstressable vowel can remain unstressed. It might therefore be possible to formulate Schwa Deletion V not as a rule which deletes floating /ə/, but as a rule which deletes unstressed /ə/. After the application of Schwa Support, unstressable vowels are vowels in the usual sense -- segments associated with V-slots. Ordering Schwa Deletion V after Schwa Support would therefore allow us to formalize syncope for this class of cases as a

deletion rule of a conventional type, the deletion of an unstressed initial vowel.

I know of only one type of case in which the choice between these two formal alternatives would have empirical consequences. When the stress phrase is larger than the word, it should in principle be possible for a stressable word-initial /ə/ to remain unstressed. If Schwa Deletion V is in fact applicable to any word-initial unstressed vowel, it should be able to delete stressable /ə/ in just this class of cases. Stating syncope as in (370) will continue to restrict deletion to unstressable vowels. No data is presently available which would permit us to choose between these analyses.<sup>24</sup>

### 5.9.1 Deletion before obstruents

In many cases, the deletion of word-initial /ə/ before an obstruent can be attributed to Schwa Deletion I. Some typical examples of this type are given in (371)-(374). I give the underlying form of the stem first in each set of examples, then forms with and without the alternating stem-initial /ə/.

(371) a. /əpəsənote-/

'basket'

b. ht-əpəsənòt

3-basket

'his basket'

c. pəsənòt

'basket'



(372) a. /ətəli-ne-/

'be dying'

b. ht-ətəlí-na-n

3-ongoing-die-SUBORD

'he is dying (Subordinative)'

c. təlí-ne

ongoing-die-(3)

'he is dying'

(373) a. /əkʷət-əp-oti-/

'chair'

b. ht-əkʷt-əp-òt

3-on-sit-instrument

'his chair'

c. kʷət-əp-òt

on-sit-instrument

'chair'

(374) a. /əsi-h-əm-əw-/

'give (someone) something to drink'

b. ht-əsi-h-m-ów-a-l

3-give.drink-TI-TI-TA-DIR-3.OBV

'he gives the other something to drink'

c. sí-h-m-ow-à-t

give.drink-TI-TI-TA-DIR-3AN-(SUBJ)

'if he gives the other something to drink'

Some schwas which are exceptions to pre-obstruent syncope in word-internal contexts are also exceptions to syncope in word-

initial position. The initial schwas of /əpi-/ 'sit, be located,' /əkisi-/ 'read,' and /əkim-/ 'read, count, instruct' show this behavior. These vowels were identified as exceptions to Schwa Deletion I in 5.2.7. The examples in (375) show that they are also exceptions to word-initial syncope.

- (375) a. əpí-n  
           sit-2  
           'sit (sg.)!'
- b. əkíso  
           read-(3)  
           'he reads'
- c. əkím-à-n  
           count-DIR-2  
           'count (sg.) them!'

Now if all of the exceptions to pre-obstruent syncope in medial positions were also exceptions in initial position, we could simply attribute all cases of syncope before obstruents to Schwa Deletion I. As it happens, though, some schwas which are exceptions to syncope in word-internal positions are either optionally or obligatorily subject to syncope at the beginning of a word. For example, the /ə/ of /-əkəkí(m)-/ 'teach' is never subject to pre-obstruent syncope when it does not begin a word, but is consistently deleted when initial:

- (376) a. nát-əkəkím-â  
 go-teach-3PASS  
 'he goes to school'
- b. mét-əkəkí-ti-n  
 finish-teach-RECIP-UNSPEC  
 'school is over'
- (377) a. kékím-â  
 teach-3PASS  
 'he attends school'
- b. kékí-ti-n  
 teach-RECIP-UNSPEC  
 'there is school'

The initial /ə/ of /əkələh-/ 'encourage to stay' is a consistent exception to pre-obstruent syncope within the word. The initial /ə/ of the root /əcəss-/ 'color' is likewise an exception to pre-obstruent syncope in most word-internal environments.<sup>25</sup> Both /əkələh-/ and /əcəss-/ are variably subject to word-initial syncope, however. Thus some speakers use (379a) while others have (379b) and I find both (380a) and (380b) in my notes, but we do not find comparable variation in forms like those in (378), where /əkələh-/ and /əcəss-/ occur within a word.

(378) a. h-kís-əkélah-a-l

3-past-encourage.to.stay-DIR-3.OBV

'he encouraged the other to stay'

b. wəl-əcəl-ə-o

good-color-AI-(3)

'he is of a good color'

(379) a. əkélöh-óti-n

encourage.to.stay-RECIP-UNSPEC

'people are trying to get the guests to stay on'

= b. kélöh-óti-n

(380) a. əcáss-áwe

color-AI-(3)

'he dyes'

b. cáss-í-kən

color-AI-NOM

'dye'

Clearly pre-obstruent syncope and syncope in initial position have different, though overlapping, sets of exceptions. It is interesting, however, that there are no examples of one logically possible type of exception. I know of no morphemes in which /ə/ is an exception to syncope in initial position but undergoes pre-obstruent syncope regularly in word-internal environments.

The observed pattern of exceptions is exactly what we expect if Schwa Deletion I and Schwa Deletion V are distinct rules, either of which may be applicable to a word-initial /ə/ before an

obstruent. If a morpheme-initial /ə/ is an exception to both rules, it will be retained both at the beginning of a word and word-internally. If a morpheme-initial /ə/ undergoes Schwa Deletion I regularly, then it will be subject to syncope both initially and medially. Marking such a /ə/ as an exception to Schwa Deletion V would have no empirical consequences. If a morpheme-initial /ə/ is an exception to Schwa Deletion I but not to Schwa Deletion V, then it will be retained word-internally but not word-initially. No combination of exception features will allow a /ə/ to be retained word-initially but not medially. To be maintained word-initially, the /ə/ would have to be an exception to both Schwa Deletion and Schwa Deletion V. But if this /ə/ is an exception to Schwa Deletion I, then it will be an exception to pre-obstruent syncope in all positions.

### 5.9.2 Deletion before sonorants

Unstressable word-initial /ə/ is deleted before sonorants as well as before obstruents. Deletion before /l/ is especially common. In fact l appears in initial position almost exclusively through the deletion of underlying initial /ə/. Several examples in which -əl- alternates with l- are given in (381)-(384).

- (381) a. nt-əl-àp  
 1-thus-look  
 'I look thus, there'
- b. l-àp  
 thus-look  
 'look (sg.) there!'
- (382) a. ht-əlámí-ptin  
 3-inside-hand  
 'the palm of his hand'
- b. lámí-ptin  
 inside-hand  
 'palm of the hand'
- (383) a. nt-əlòhk  
 1-work-(AI)  
 'I work'
- b. lòhk-e  
 work-AI-(3)  
 'he works'
- (384) a. ht-əláhkap-əm  
 3-cellar-POSS  
 'his cellar'
- b. láhkap  
 'cellar'

For the roots /əl-/ 'thus, there' and /əlòhk-/ 'work, do,'  
 underlying initial /ə/ is confirmed by Changed forms like those in  
 (385)-(386). For /əlòhk-/ there is additional evidence for

underlying /ə/ from stems in which this root forms part of a complex final, as in (387).<sup>26</sup>

(385) éł-ápi-t  
thus-look-3AN  
'the way he looks (at something)'

(386) élohk-è-t  
work-AI-3AN-(PERF)  
'when he worked'

(387) nát-əłóhk-e  
go-work-AI-(3)  
'he goes to work'

Deletion of initial /ə/ before /n/ is attested in the noun /ənekəson/ 'sleeping mat,' which may be either animate or inanimate:

(388) a. ht-ənékəson  
~ ht-ənekəsón- l  
3-sleeping.mat-3.OBV  
'his sleeping mat'  
b. nékəson  
'sleeping mat'

Initial /ə/ is deleted before /w/ in about half a dozen roots, including /əwas-/ 'child,' /əwapəl-/ 'improper,' /əwehk-/ 'use,' /əwik-/ 'write, draw, etc.,' and /əwawik-/ 'mixed.' The last of these has an alternative underlying form without the initial /ə/. Since stressable /ə/ surfaces as o before w,

syncope results in an alternation between ow and w in these roots in (389)-(393).

(389) a. nt-<sup>ó</sup>was-<sup>ís</sup>-<sup>ò</sup>

1-child-DIM-AI

'I am young'

b. <sup>was</sup>-<sup>is</sup>-<sup>əwí</sup>-<sup>w</sup>

child-DIM-AI-3

'he is young'

(390) a. ht-<sup>ó</sup>wap<sup>ə</sup>li-<sup>tahá</sup>-m-a-l

3-improper-think-TA-DIR-3.OBV

'he thinks about the other improperly;

he thinks there is something wrong with the other'

b. <sup>wap<sup>ə</sup>l</sup>-<sup>əlohk</sup>-<sup>e</sup>

improper-work-AI-(3)

'he does something wrong'

(391) a. kt-<sup>ó</sup>wéhk-<sup>á</sup>-ni-ya-l

2-use-TI-3IN-22-33IN

'you (pl.) use them (in.)'

b. <sup>má</sup> te <sup>wéhk</sup>-<sup>á</sup>-w-<sup>ə</sup>n

not EMPH use-TI-NEG-UNSPEC

'it is not being used'



- (392) a. nt-ó<sup>́</sup>wik-hí-k  
 1-write-TA-AI  
 'I write, draw, etc.'
- b. wí<sup>́</sup>k-hí-ke  
 write-TA-AI-(3)  
 'he writes'

- (393) a. ht-ó<sup>́</sup>wáwik-é<sup>́</sup>hto-n  
 ~ wáwik-é<sup>́</sup>hto-n  
 3-mixed-TI-3IN  
 'he mixes it'
- b. wáwik-é<sup>́</sup>htà-kw  
 mixed-TI-3AN-(SUBJ)  
 'if he mixes it'

Underlying initial /ə/ is confirmed, however, by the Changed forms in (394), where this segment is replaced by /e/. Note that the variation in (394e) correlates with that in (393a).

- (394) a. éwás-is-əwí-t  
 child-DIM-AI-3AN-(PERF)  
 'when he was young'
- b. éwapəlí-kə-k  
 improper-kind-3IN  
 'that which is improper'
- c. éwéhk-e-t  
 use-TI-3AN  
 'when he uses it'

- d. éwík-hi-kè-t  
 write-TA-AI-3AN-(PERF)  
 'when he wrote'
- e. éwawík-eh̀ta-kw  
 ~ wawík-eh̀ta-kw  
 mixed-TI-3AN-(PERF)  
 'when he mixed it'

In the case of /əwehk-/ and /əwik-/, there is further support for underlying forms which contain an initial syncopating vowel from stems in which these morphemes occur as non-initial elements. Since /ə/ is not subject to syncope before sonorants except in the environment for Geminate Deletion, the hypothesized schwas appear on the surface in (395).

- (395) a. n-kís-əwéhk-a-n  
 1-past-use-TI-3IN  
 'I used it'
- b. təl-əwik-hí-ke  
 ongoing-write-TA-AI-(3)  
 'he is writing'

### 5.9.3 Deletion and stressability

The initial /ə/ of a morpheme like /əlam-/ 'inside' or /əlohk-/ 'work, do' will always be unstressable at the beginning of a word, since it is always followed by a syllable which contains a stressable vowel. Word-initial /ə/ is therefore

subject to syncope whenever such a morpheme begins a word. The initial /ə/ of a morpheme like /ə́ləm-/ 'away,' /ə́lən-/ 'Indian,' or /ə́ləkw-/ 'direction,' on the other hand, will always be stressable, since it is followed by an unstressable /ə/ in word-initial /(C)ə[+sonorant]ə/. Thus word-initial /ə/ never undergoes syncope in this type of morpheme:

- (396) a. ə́ləm-apáə-w-ək  
 away-pl.walk-3-33PROX  
 'they (pl.) walk away'
- b. ə́lən-áksən  
 Indain-shoe  
 'moccasin'
- c. ə́ləkw-ék-te  
 direction-sheet-located-(3)  
 'it is folded back thus'

A possible case of the same type involving /əw/ is provided by the II verb ə́wən 'it is foggy, misty.' Changed Conjunct forms like ə́wə-k (foggy-3IN-(PERF)) 'when it was foggy' suggest that the underlying stem of the verb may be /ə́wən/. We will see in 9.3, however, that Initial Change is not a reliable test for underlying forms where ow alternates with ew.

The clearest evidence of the role of the stressable/unstressable distinction in word-initial syncope comes from forms which contain the root /ə́l-/ 'thus, there.' When /ə́l-/ is followed by a stressable vowel, its /ə/ is subject to syncope in word-initial position, as shown in (397). When /ə́l-/ is followed instead by an unstressable vowel, as it is in (398), its /ə/ is

stressable because it falls under the generalization which governs stressability in word-initial / $(C)\text{ə}$  [+sonorant]  $\text{ə}$ /, and syncope does not take place.

- (397) a. l-éyo  
 thus-happen-(3)  
 'it happens thus, it is true'
- b. lí-wí-so  
 thus-name-AI-(3)  
 'he is named thus'
- c. l-óhse  
 thus-walk-(3)  
 'he walks thus, there'

- (398) a. ə́l-ə́nók-ət  
 thus-event-II-(3)  
 'it happens thus'
- b. ə́l-ətə́kko  
 thus-jump-(3)  
 'he jumps thus, there'

Word-initial / $\text{ə}$ / is retained in the forms in (399) for the same reason, but here the second / $\text{ə}$ / in / $(C)\text{ə}$  [+sonorant]  $\text{ə}$ / is subject to syncope, obscuring the conditions which determine that the / $\text{ə}$ / of / $\text{ə}l-$ / will be treated as stressable in these forms. In (399a), underlying /- $\text{ə}k\text{ihkw}\text{ə}n-$ / loses its initial / $\text{ə}$ / by Schwa Deletion I, while /- $\text{ə}h\text{ə}m-$ / is reduced to - $h\text{ə}m-$  by Schwa Deletion II in (399b).

- (399) a. ʔ́l-kíhkwən  
 thus-size-(3)  
 'it is big by so much'
- b. ʔ́l-həm  
 thus-swim-(3)  
 'he swims thus, there'

The /ʔ/ of /ʔ́l-/ is subject to syncope in the examples in (400), despite the fact that the next vowel is /ʔ/, because the second /ʔ/ in /ʔ́lʔ/ in these forms is a stressable vowel, the result of the application of I-Backing in underlying /ʔ́li-hsəmi-w/ and /ʔ́li-hsin-w/.

- (400) a. lʔ́-ssəmo  
 thus-drink-(3)  
 'he drinks thus'
- b. lʔ́-ssin  
 thus-lie-(3)  
 'he lies thus, there'

The role of the configuration /((C)ʔ [+sonorant]ʔ/ in determining whether initial /ʔ/ undergoes syncope is the result of the fact that Initial Syllable Epenthesis precedes Schwa Deletion V. We can see this by comparing the derivations of l-ʔ́hse 'he walks thus, there' and ʔ́l-ʔ́nók-ʔ́t 'it happens thus.'

The syllabified underlying form of lʔ́hse is (401). Since none of the rules of V-slot epenthesis is applicable here, the

initial /ə/ of /l-/ remains unstressable here and is deleted by Schwa Deletion V.

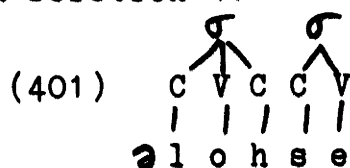

As we noted at the beginning of this section, this deletion must take place at the phrase level. Since Schwa Deletion V does not reduce a word like wəlí-ko (good-kind-(3)) 'it is good (for use)' to \*wli-ko, word-initial unsyllabified C must be able to block the application of this rule. At the word level, however, an initial C which precedes an unstressable /ə/ cannot be syllabified and will therefore be extrametrical and invisible to phonological rules.

The representation of əl-ənók-ət 'it happens thus' after the application of Final Syllable Epenthesis is (402a). Here Initial Syllable Epenthesis is applicable; it converts this structure into (402b). If Schwa Deletion V is formulated as in (370) above, it will not apply in (402b) because the initial /ə/ in this representation is no longer a floating vowel. If Schwa Deletion V is instead formulated as the deletion of an unstressed vowel, it will be inapplicable here because stress is assigned to the first syllable of (402b) by the Initial Stress Rule. In either case, the initial /ə/ of /əl-/ will be retained on the surface in this word.

(402) a.

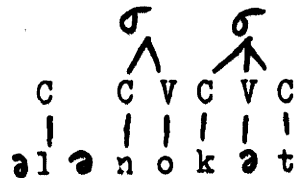

b.

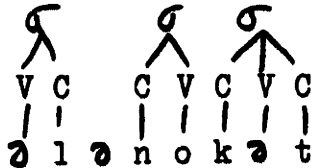

In derivations like this, Initial Syllable Epenthesis bleeds Schwa Deletion V. The other rules of V-slot epenthesis are not applicable to word-initial /ə/.

In 5.9.1 above we noted several morphemes in which a /ə/ before an obstruent must be marked as an exception to Schwa Deletion V. This rule appears to be virtually exceptionless, however, in cases in which a sonorant follows a potential deletion site. Only in the preverb əli 'thus, there,' a derivative of the root /əl-/, is it sometimes possible to retain a word-initial unstressable /ə/ before a sonorant, as in (403a). Compare (403b), in which /əli/ undergoes syncope regularly.

(403) a. cówi əlí pəm-áwsó-w-ək

should thus along-live-3-33PROX

'they should live thus'

b. lí kisi cən-éht-áso

thus can stop-TI-II-(3)

it can be stopped thus'

Schwa Deletion V appears to be optional in this morpheme.

1. Some speakers also use forms based on an alternative stem /kəttək-wəni-/, e.g. n-kəttək-wən 'I stay over.'

2. Some speakers have tət-kil 'he is big to such an extent' and tət-əkikhwən 'it is big to such an extent' instead of tət-kil and tət-kihkwən, apparently taking the initial schwas of /-əkil-/ and /-əkikhwən-/ to be exceptions to pre-obstruent syncope in these stems. Other stems made with these finals show regular patterns of syncope, however, for all of my consultants.

3. The /ə/ of the stem /səki-/ 'urinate' is apparently an exception to pre-obstruent syncope in səko (urinate-(3)) 'he urinates' (accent uncertain), although syncope takes place regularly in the related final: n-táhəwi nácł-sk (1-must go-urinate) 'I have to go somewhere and urinate.'

4. There is also an alternate surface form kəspison, apparently with inherently stressable /ə/.

5. Apparently it is more natural, however, to insert /-aləkittiye-/ after /-əton(e)-/, giving h-kəp-tón-aləkittiyé-n-a-l. The loss of the unstressable /ə/ of /-əton(e)-/ after a stressable vowel in the two alternants in the text is regular; this alternation is discussed in 8.2. The alternation between /-əton-/ and /-ətone-/ reflects a type of allomorphy which is common to a number of medials.

6. Hockett (1957:257) gives \*kep- 'closed, blocked' for Proto-Algonquian in \*kepetone.nə.wa 'he covers his mouth or opening by hand' and a variety of other derivatives. Passamaquoddy /kəp-/ is the expected reflex of PA \*kep-.

7. Note, however, that it is precisely the non-alternating occurrences of ə which are derived from a source other than the /ə/ in this account.

8. Actually, there is a flaw in this argument, apart from the empirical problems noted below: if (116) and (118) had consistent sets of exceptions, there would be no reason to suppose that any occurrences of /ə/ before obstruents are deleted by (118). Under these circumstances, we could simply generalize (116) so that it would also delete word-initial /ə/, leaving only cases of deletion before sonorants to be handled by (118). The apparent argument for an abstract segment would then no longer go through.

9. Cf. the preverb méhsi 'why, (what) for,' which occurs only in Changed forms, in which it bears the change. For the semantic connection between msi and méhsi, cf. the preverb hsámi 'too much, too many; because.'

10. In principle at least, Initial Devoicing might be applicable to the prefix /n-/ in forms based on stems like /sp-əpi-/ 'sit up high' which begin with underlying clusters as the result of reanalysis of syncopated surface stems. In practice, however, the prefix is usually dropped in such forms; and in any case /h/ in the output of devoicing would be deleted before the cluster. There also seems to be some partial voicing of the first obstruent in stem-initial clusters of this kind after /n-/, at least in the rather artificial style in which the prefix is pronounced.



11. Prince also gives "w'keyowak'n'k" 'in his anger' in the same passage as (181b) (1921:72). But this form, which is probably a calque on the English expression, must be ôhkayawâkanak (< /w-wâhkayi-w-akân-k/ 3-angry-DA-NOM-LOC). Cf. "w'simis'l" 'his younger brother' (also p. 72) for ôhsimisal 'his younger sibling.' Prince usually uses "â" to represent the lightly rounded allophone of a which occurs after labial consonants. Perhaps, then, (181b) might be interpreted as showing some rounding of the k in initial wk.

12. Presumably this would include s in initial sC clusters, which should therefore (optionally, as we will see) have the phonetics of medial clusters of this type when following a vowel-final word. The principal difference would be in the phonetic length of s: this segment should be long in syllable-final position before a non-syllabic. I have not attempted to check this prediction.

13. Note, however, that e is phonetically [ɛ̃] rather than [æ̃] before hC across a word boundary. Thus the rule which lowers e before h must either be restricted to word-internal contexts or ordered before Initial Devoicing.

14. I am grateful to Karl Teeter for bringing the Henry Prince material to my attention.

15. Maj. Prince apparently used "â" to represent [a], not [ɔ̃]. Thus his "Oo-kât'" does not indicate a pronunciation of this word with rounding of the k.

16. The short forms of the prefixes are used before non-syllabics and in dependent nouns. The long forms appear elsewhere (i.e. before both stressable and unstressable vowels). I assume that this distribution is stated by means of non-phonological rules of allomorphy. See Bochner (1988) for a non-phonological account of prefix allomorphy in Passamaquoddy in a word-based model of the lexicon.

17. Note once again that the constraint on syncope which prevents the derivation of \*tâl-skwe cannot be reduced to an output condition. Compare pîlskwêhsis 'girl,' mâlskwêsital 'beans,' which show that there is nothing anomalous about the cluster lskw.

18. For an analysis of verbs of possession in Maliseet, see Sherwood (1983a).

19. In forms like those in (203), the verbal morphology makes the use of the first and second person prefixes obligatory. Even in positions where the verbal morphology does not call for the use of a personal prefix, however, the first or second person prefix may replace the third person prefix, if the replacement is semantically appropriate. Thus both n-mâce n-ôniyakânî-n (1-start 1-head-ache) and n-mâce w-ôniyakânî-n (1-start 3-head-ache) are possible in the meaning 'I am starting to have a headache.'

20. This treatment of verbs derived from dependent nouns dates to Proto-Algonquian (Bloomfield 1946, sections 68, 103).

21. Geminate cc sometimes occurs in place of English c in borrowings: riccat 'Richard.'

22. The first of these examples has /a/ for stem-final /e/ as a result of a vowel mutation triggered by the suffix /-n(e)/.

23. The conditions which govern the reduction of /ihi/ to hi have not been fully determined, but it is clear that the rule

involved is not restricted to deleting /i/ after /hC/. For example, one hears wénihi ~ wénihi 'who (obv. pl.).'

24. The relevant forms will all involve vowel sequences across word boundaries, which in any case are subject to various phonetic rules whose nature remains to be determined.

25. Although apparently not after /kis-/ 'past': compare ht-əcəss-əm-n (3-color-TI-3IN) 'he dyes it,' h-kis-cəss-əm-ən (3-past-color-TI-3IN) 'he dyed it.'

26. To handle the schwa/zero alternations in forms like (381)-(384), Teeter (1973:196) proposes a rule which inserts /ə/ after a prefix and before /l/. A complication of his statement of Initial Change (p. 209) then accounts for initial e in examples like (385)-(386). It seems to me that this proposal must be rejected. If we set up underlying /lohk-/ 'work,' for example, then we will incorrectly predict \*nacilohke in place of (387). Surface occurrences of əl- 'thus, there' before l (where the l of l- is stressable; see below) cannot be derived by the proposed "ə-vocalization of the liquid." Nor can Teeter's account of the schwa/zero alternation before /l/ be extended to cases involving n and w like those discussed below, since only a few initials which begin with these segments in their unprefixated forms add a vowel in prefixated and Changed forms.

Nevertheless, Teeter's proposal accounts for an asymmetry in the underlying distribution of /l/ which is here left unexplained. Even in borrowings, initial l is usually taken to be derived from /əl/. Thus lahkap 'cellar,' from French la cave, is derived from /əlahkap/, as we can see from (384). Likewise the stem of lapás-ək 'rubbers (raingear)' must be /əlapas/, since we find possessed forms like nt-əlapas-əm (1-rubber-POSS) 'my rubber.'

## Chapter 6

### Syncope of /i/, /a/, and /o/

Certain occurrences of i, a, and o which cannot be derived from /ə/ by assimilation across /h/ or by lowering before /hm/ nonetheless alternate with zero under conditions which involve the stressable/unstressable distinction. These syncopeating vowels are found in a restricted set of environments. With three or four exceptions, syncopeating i and o occur only before hC, where C is an obstruent, while syncopeating a occurs only before hC or sC. Even in these contexts, non-alternating i and a are much more common than their alternating counterparts. Non-alternating o is also common before hC, while alternating o occurs only in a few morphemes; but non-alternating o is rare before hkw, where alternating o is best attested. Many of the alternations in question are not consistently maintained by younger speakers. Even the speech of my oldest consultants reflects a considerable amount of leveling.

Alternating i, a, and o not only undergo syncope like /ə/, but participate like /ə/ in the assignment of stressability to other segments. I will demonstrate below that this behavior is easily accommodated within the CV theory of stressability by setting up syncopeating i, a, and o as underlying floating /i/, /a/, and /o/. We can then account for their role in determining

stressability by generalizing V-Epenthesis and Final Syllable Epenthesis so that they apply not only to floating /ə/ but to any floating vowel. We can account for the fact that these occurrences of i, a, and o undergo syncope by generalizing Schwa Deletion I and Schwa Deletion II in the same manner. We will see, however, that S-HS Epenthesis must still be restricted to supplying V-slots for schwas, since unstressable /a/ may be deleted between /s/ and /hs/. (Unstressable /i/ and /o/ are not found in this environment.)

The restricted distribution of syncopting i, a, and o remains unexplained in this account. The analysis of syncope proposed by Sherwood (1983b) is of interest in this connection, since it appears to offer an explanation for this distribution. I will argue, however, that Sherwood's proposal faces significant difficulties which suggest that it cannot be maintained.

In Sherwood's analysis, /ə/ and /ǣ/ are the sources of syncopting i and a, respectively, where /ǣ/ is the special <sup>pho</sup> morphoneme, distinct from any surface segment, which he also sets up in underlying forms for surface schwas which do not undergo syncope before obstruents. (In the analysis that I have given in Chapter 5, all of these schwas are derived from underlying /ə/, but some are inherently stressable, and thus regularly fail to undergo syncope, while others are lexically marked as exceptions to Schwa Deletion I and Schwa Deletion V.) He takes both /ə/ and /ǣ/ to be subject to syncope before /hC/. Where syncope does not take place, /ə/ merges with /i/ as /i/ and /ǣ/ merges with /a/ as /a/ before /hC/. Because /ə/ and /ǣ/ become i and a only before /hC/, it follows that syncopting i and a occur only in this

environment. The analysis can be straightforwardly generalized to account for syncope of a before /sC/.

Sherwood's proposal has a clear historical rationale: it essentially reestablishes in underlying forms the conditions which must have obtained when syncope entered the phonology of Maliseet-Passamaquoddy. Nonetheless this analysis is open to serious objections both on methodological and on empirical grounds.

Methodologically, the analysis is suspect because it postulates an abstract segment and a rule of absolute neutralization, the rule which gives surface ə for any /ǎ/ which remains after the conditioned merger of /ǎ/ and /a/. (See 5.2.13 for a discussion of this point.) A further problem results from the fact that /ə/ and /ǎ/ could be systematically exchanged before /hC/ and /sC/ without requiring any significant complication of the analysis. Thus the roles assigned to /ə/ and /ǎ/ in this proposal are essentially arbitrary from a synchronic point of view.

Empirical difficulties arise when we attempt to generalize Sherwood's analysis to account for syncope of o. Since syncope of i, a, and o can all appear in the same environment, syncope of o cannot be derived from either /ə/ or /ǎ/ by any general rule.

Because /ə/ and /ǎ/ become i and a before /hC/ under Sherwood's proposal, surface əhC is excluded. Sequences of this form do occur in Passamaquoddy, however, although they are rare. (Sherwood reports the corresponding Maliseet forms without h, although I have recorded some forms with əhC in Woodstock

Maliseet.) The relevant examples appear to reflect the effects of analogy on allomorphy in certain inflectional suffixes. The fact that analogy has given rise to surface əhC suggest that such sequences are no longer excluded by a phonological constraint.<sup>1</sup>

I conclude that the restricted distribution of syncoating i, a, and o has an historical explanation but no synchronic statement in the phonology of Passamaquoddy.

The chapter is organized as follows. Sections 1-3 provide a summary of the available data on syncoating i, a, and o. Section 4 presents an analysis of the alternations in question within the framework of the CV theory of stressability. Section 5 gives a brief account of the historical basis for an alternative analysis like that proposed by Sherwood, but argues against a synchronic account which recapitulates the history of the forms. Section 6 examines the interaction between the deletion of /i/ in syncope and the palatalization of /t/ to /c/. A careful analysis of the contexts in which palatalization takes place suggests that several distinct morphologically conditioned rules are involved. At least one of these, the rule by which root final /t/ becomes /c/, apparently must be ordered after Schwa Deletion II, a surprising result in view of the fact that this syncope rule can be stated in purely phonological terms. As a preliminary to the discussion of palatalization, a formal statement of the rule for the use of connective /i/ is also proposed in this section.

## 6.1 Syncopating /i/

Non-alternating /i/ is common before /hC/, as shown in (1) and (2).

- (1) a. piht-ákam-e  
long-lake-II-(3)  
'it is a long lake'
- b. kihtahkwé-he  
dizzy-go-(3)  
'he is dizzy'
- c. cihki-hí-ke  
sweep-TA-AI-(3)  
'he sweeps'
- d. mihkwi-táha-m-i-yin  
sudden-think-TA-1.OBJ-2-(SUBJ)  
'if you (sg.) happen to think of me'
- (2) a. ámihk-ésso  
up-move-(3)  
'he gets up (from sitting)'
- b. nátam-ákihkwán  
fairly.big-size-(3)  
'it is fairly big'
- c. məlihki-ptin-e  
strong-hand-AI-(3)  
'he has strong arms, hands'

Syncopating /i/, while not rare, occurs in relatively few morphemes. The examples in (3)-(8) shown i in alternation with

zero in the roots /kiht-/ 'big, great,' /kihtəm-/ 'disinclined,' /mihkw-/ 'red,' /nihtak-/ 'mourn,' /nihtaw-/ 'know how, be good at,' and /nihtop-/ 'catch.' Here /i/ surfaces or undergoes syncope just like an underlyingly unstressable /ə/ as the location of stressable and unstressable positions changes with prefixation. The same pattern appears in noun inflection, as shown in (9). The syncoating forms in the following examples reflect not only the loss of /i/ but also the deletion of /h/ between non-syllabics by a rule which will be formalized in 6.4.1.

(3) a. n-kíhci-kətən  
 1-big-year-(AI)

'I am old'

b. kci-kətən-e  
 big-year-AI-(3)  
 'he is old'

(4) a. n-kihtəm-át-əm-ən  
 1-disclined-TI-TI-3IN  
 'I do not feel like doing it'

b. ktəm-at-ə-k  
 disclined-TI-TI-3AN-(SUBJ)  
 'if he does not feel like doing it'



- (5) a. mihkw-aləki-kw-a-n  
 (3)-hole-face-AI-SUBORD  
 'his eyes are red (Subordinative)'
- b. pkw-aləki-kw-e  
 red-hole-face-AI-(3)  
 'his eyes are red'
- (6) a. nihtək  
 (1)-mourn-(AI)  
 'I am in mourning'
- b. htək-o  
 mourn-AI-(3)  
 'he is in mourning'
- (7) a. nihtaw  
 (1)-know.how-(talk)  
 'I know how to talk'
- b. ntéw-é-hpən  
 ~ htaw-é-hpən  
 know.how-talk-PRET  
 'he knew how to talk'
- (8) a. nihtóp-h-a-l  
 (3)-catch-TA-DIR-3.OBV  
 'he catches the other'
- b. nəkəsa      ntóp-h-a-l  
 ~ nəkəsa      htóp-h-a-l  
 (3)-quickly catch-TA-DIR-3.OBV  
 'he catches the other quickly'

- (9) a. pkáhkəníkən  
           'crooked knife (woodworking tool)'  
 b. h-píhkəhəkən  
           3-crooked.knife  
           'his crooked knife'

Where syncopating /i/ is the first vowel of a stem, it is replaced by /e/ in Initial Change: kéhčí-kətən-è-t (big-year-AI-3AN-(PERF)) 'when he was old.' I will return to this matter in 9.2.

Syncopating /i/ is the second vowel in the roots /nəkihka-/ 'all, completely' and /kəsihka-/ 'lose.' Here /i/ is deleted in prefixed and Changed forms but retained in unprefixed forms without Initial Change, where the preceding /ə/ is syncopated instead.

- (10) a. hkihká-ne  
           all-die-(3)  
           'he is completely dead'  
 b. nəkká-na-n  
           (3)-all-die-SUBORD  
           'he is completely dead (Subordinative)'  
 c. nəkka-nè-t  
           all-die-3AN-(PERF)  
           'when he was completely dead'

- (11) a. ksíhká-hta  
 lose-AI-(3)  
 'he loses something'
- b. h-káská-hta-n  
 3-lose-AI-PEG  
 'he loses it'

Alternations in the stem of the verb hkápo ~ khápo 'he is blind' were discussed in 5.3.2 in connection with the phonetics of word-initial hC and Ch. Some speakers use forms like those in (12), suggesting /nikhapi-/ as the underlying form of this stem. Others have the forms in (13), suggesting underlying /nikhapi-/ instead.

- (12) a. níhkáp  
 (1)-blind  
 'I am blind'
- b. néhkápí-t  
 blind-3AN-(PERF)  
 'when he was blind'
- c. hkápo  
 blind-(3)  
 'he is blind'

- (13) a. níkhàp  
 (1)-blind  
 'I am blind'
- b. nékhapì-t  
 blind-3AN-(PERF)  
 'when he was blind'
- c. khápo  
 blind-(3)  
 'he is blind'

For speakers in the second group, alternating i is not followed by surface hC in this verb, a situation not otherwise attested. It would, of course, be possible to set up underlying /nihkhapi-/ for the forms in (13) and let H-Deletion III apply in the derivation of forms like (13a) and (13b). Note, however, that the first /h/ in putative underlying /hkh/ would be deleted in every form of this verb.

The medial /-ihte-/ 'strike' is typical of several non-initial morphemes which begin with syncopating /i/. The underlying /i/ of this element is obligatorily retained on the surface under the same conditions as underlyingly unstressable /ə/. Thus we find surface -ihte- after a cluster other than /hC/, as in (14a,b), and after unstressable /ə/ and a single C, as in (14c-e).

- (14) a. ht-áps-ihte-h-m-ən  
 3-small-strike-TI-TI-3IN  
 'he chops it into small pieces'

- b. h-tám-ápsk-ihté-h-m-ən  
 3-in.two-round-strike-TI-TI-3IN  
 'he chops it into sections'
- c. ht-təl-ihté-h-m-ən  
 3-ongoing-strike-TI-TI-3IN  
 'he is hitting it'
- d. h-tów-álək-ihté-h-m-ən  
 3-through-hole-strike-TI-TI-3IN  
 'he puts a hole through it by hitting it'
- e. ks-átək-ihté-hsin  
 intense-line-strike-lie-(3)  
 'it (an., soething string-like) strikes,  
 pounds against something'

Conversely, the /i/ of /-ihte-/ may be syncopated under the same conditions as underlyingly unstressable /ə/. Thus we find -te- for /-ihte-/ after a stressable vowel and a single non-syllabic in (15a,b).

- (15) a. míyaw-té-h-m-ən  
 (3)-precise-strike-TI-TI-3IN  
 'he hits it with a well aimed blow'
- b. h-kəpp-ek-té-h-m-ən  
 3-close-sheet-strike-TI-TI-3IN  
 'he covers it by hitting something two-dimensional'

The /i/ of /-ihte-/ also drops after a stressable vowel and a cluster of /h/ and an obstruent. In (16) and (17) the roots /pehk-/ 'completely' and /nahs-/ 'on (as clothing, a ring over a

post, etc.)' are first shown in their full forms, then in combination with /-ihte-/. Where the /i/ of /-ihte-/ undergoes syncope, preceding /hC/ is redced to C by H-Deletion III.

- (16) a. h-péhk-ákənotə~~m~~-ów-a-n  
 3-completely-TA-DIR-PEG  
 'he tells the other all about it'
- b. h-pék-té-h-m-ə~~n~~  
 3-completely-strike-TI-TI-3IN  
 'he hits all of it; he gets it all'
- (17) a. náhs-éhto-n  
 (3)-on-TI-3IN  
 'he put it (clothing) on'
- b. nás-té-h-m-ə~~n~~  
 (3)-on-strike-TI-TI-3IN  
 'he hits it to make it go on'

In (18a-c), the /i/ of /-ihte-/ is deleted after a syllable containing a stressable /ə/. In (18a) this /ə/ is stressable because it follows the prefix /nt-/. In (18b), the corresponding /ə/ is stressable by alternating stressability because it is the second /ə/ in underlying /atəl-/ 'ongoing.' In (18c), the /ə/ of /tək-/ 'hit' is inherently stressable.

- (18) a. nt-əl-té-h-m-ən  
 1-thus-strike-TI-TI-3IN  
 'I hit it there'
- b. təl-te-h-m-àn  
 ongoing-strike-TI-TI-1-(SUBJ)  
 'if I am hitting it'
- c. tək-te-hká-so  
 hit-strike-by.foot-REFLEX-(3)  
 'he kicks himself'

Especially striking is the fact that the /i/ of /-ihte-/ may be deleted in word-initial /(C)ə [+sonorant] i/, just as the second /ə/ in word-initial /(C)ə [+sonorant]ə/ is typically subject to syncope. Two cases are shown in (19). In (19b), the /e/ of /-ihte-/ becomes a by assimilation to a following vowel across /h/.

- (19) a. təm-té-hsən  
 in.two-strike-lie-(3)  
 'it strikes something and breaks'
- b. əl-tá-h-â  
 thus-strike-TA-3PASS  
 'he is hit thus'

The pattern of deletion and retention that we find for /-ihte-/ is repeated for the finals /-ihkət-/ 'ebb (of the tide)' and /-ihpavi-/ 'be scared.'<sup>2</sup> Examples are given in (20) and (21). Underlying forms are given where the conditioning factors for syncope are not apparent on the surface.

- (20) a. ks-ihkət (/kʷs-ihkət-w/)  
intense-ebb-(3)  
'the tide is at its lowest in its monthly cycle'
- b. ələm-ihkət  
away-ebb-(3)  
'the tide goes out'
- c. kɨs-kət  
past-ebb-(3)  
'the tide goes out'
- d. wɨkw-kwət (/wɨkw-ihkət-w/)  
take(?)-ebb-(3)  
'the tide goes out'
- e. sɨn-cək-kət  
down(?)-messy-ebb-(3)  
'the tide is at its lowest in its monthly cycle'
- (21) a. sɨs-páyo (/sɨs-ihpayi-w/)  
to.tears-scared-(3)  
'he cries because he is scared'
- b. əl-páyo  
thus-scared-(3)  
'he is scared thus'
- c. təl-páyo (/ətəl-ihpayiw/)  
ongoing-scared-(3)  
'he is scared'
- d. étəl-ihpayi-t  
ongoing-scared-3AN  
'he is scared (Conjunct)'



The material which precedes a syncopating /i/ determines its status for syncope, just as the material which precedes an underlyingly unstressable /ə/ determines its status in stress assignment. Syncopating /i/ also figures like underlyingly unstressable /ə/ in determining whether following vowels are counted as stressable, as we can see by looking at words formed with the TA final /-ihkəw-/ 'by foot, by body, by vehicle' or its TI counterpart /-ihkəm-/.

In (22a), the /i/ of /-ihkəw-/ is stressable because it follows the cluster /ss/ of /ass-/ 'meet.' This vowel is accordingly retained on the surface. The /ə/ of the next syllable is unstressable since it follows a stressable vowel and a cluster of /h/ and an obstruent. In (22b), the /i/ of /ihkəw-/ follows a stressable vowel and a single C, so here it is unstressable and undergoes syncope. The /ə/ of the final is treated as stressable, surfacing as o before w, just as if the preceding /i/ were an unstressable /ə/. In parallel fashion, the /i/ of /-ihkəm-/ is stressable in (23a) because it follows the cluster /pk/, while the /ə/ of this final remains unstressable here. In (23b), the /i/ of /-ihkəm-/ undergoes syncope and the /ə/ of this morpheme is treated as stressable.

- (22) a. ná<sup>́</sup>t-ass-íhkəw-a-l  
 (3)-go-meet-by.body-DIR-3.OBV  
 'he goes and meets the other'
- b. ná<sup>́</sup>t-kó<sup>́</sup>w-a-l  
 (3)-go-by.body-DIR-3.OBV  
 'he goes right to the other'

- (23) a. h-sípk-íhkəm- n  
 3-long.time-by.body-3IN  
 'it takes him a long time to get to it (a place)'
- b. wécəwaw-kəm-ən  
 (3)-near-by.body-3IN  
 'he nears it'

In (24a-d), the /i/ of /-ihkəw-/ is the second in a series of three vowels within which alternating stressability holds. Thus /i/ is retained on the surface in these forms and /ə/ remains unstressable in the following syllable.

- (24) a. ht-áhsəw-íhkəw-a-l  
 3-across-by.body-DIR-3.OBV  
 'he covers the other with his body'
- b. h-tétəm-íhkəw-a-l  
 3-equal-by.body-DIR-3.OBV  
 'he catches up with the other (on foot)'
- c. h-tów-álək-íhkəw-a-l  
 3-through-hole-by.foot-DIR-3.OBV  
 'he puts a hole through it by stepping on it'
- d. ht-ələm-íhkəw-a-l  
 3-away-by.body-DIR-3.OBV  
 'he forces the other to go away by following him'

As we would expect, when a preceding /ə/ is stressable because it follows the cluster created by adding a prefix, the /i/ of /-ihkəw-/ or /-ihkəm-/ is unstressable and subject to syncope and the /ə/ of the final is stressable instead:

(25) a. h-tám-ków-a-l

3-in.two-by:body-DIR-3.OBV

'he breaks the other's back by riding him;

he bothers the other, preventing him from working'

b. h-pám-ków-a-l

3-along-by.body-DIR-3.OBV

'he rides the other'

c. h-pám-kám-ən

3-along-by.body- n

'he drives it (a vehicle)'

While we can predict where deletion of syncopating /i/ is possible by treating syncopating /i/ like underlyingly unstressable /ə/, deletion is not always carried out where it is expected. Such cases do not involve true exceptions to syncope, however, since unsyncopated /i/ always surfaces as a stressable vowel.

As we might expect, alternations reflecting the deletion of /i/ are more faithfully maintained in some morphemes than in others. In my materials, /-ihkəw-/ and /-ihkəm-/ appear to alternate quite regularly. Alternation is also fairly regularly in the case of /-ihte-/, although I have recorded a number of doublets: h-tám-té-h-m-ən ~ h-tám-ih-té-h-m-ən (3-in.two-strike-TI-TI-3IN) 'he hits, chops it, breaking it in two,' tám-tə-h-ə-k-səpən ~ tám-ih-tə-h-ə-k-səpən (in.two-strike-TI-TI-3AN-DUBIT-(SUBJ)) 'if he hit, chopped it, etc.' (all forms D.F.). The final /-ihkawəti-/ 'walk (dual)' is historically derived from reciprocals formed from stems in /-ihkəw-/,<sup>3</sup> but

much less regularly loses its initial /i/ to syncope. The pattern of surface /i/ in stressable positions and syncope in unstressable positions is reflected in (26), but there are also doublets, as in (27).

(26) wíwən-íhkawátó-w-ək 'they (du.) walk around in a  
circle'

ələm-íhkawátó-w-ək 'they (du.) walk away'

pét-kawátó-w-ək 'they (du.) arrive here by  
walking'

(27) əl-kawátó-w-ək ~ 'they (du.) walk there, thus'  
l-íhkawátó-w-ək

mác-kawátó-w-ək ~ 'they (du.) walk badly, sexily'  
mác-íhkawátó-w-ək

A similar mix of forms with and without expected syncope of /i/ is found in the case of the medial /-ihtakw-/ 'sound, noise.' Syncope follows its regular pattern in (28a,b), but I have recorded doublets for (28c,d). (Surface oht reflects intermediate /owt/ from underlying /owiht/ in (28c).)

(28) a. wécawaw-takw-so  
near-sound-AI-(3)  
'he sounds close (talking)'

b. əl-takw-ət  
thus-sound-II-(3)  
'it sounds thus'

c. ckóh-tákw-ət

~ cków-ihtákw-ət

hither-sound-II-(3)

'it sounds as if it is approaching'

d. məc-tákw-ət

~ məc-ihtákw-ət

'it sounds bad'

One aberrant case should be noted here. The /i/ of /-ihtákw-/ 'sound' is unexpectedly subject to syncope after the /ss/ of /cəss-/ 'bother' in cəs-tákw-so (bother-sound-AI-(3)) 'he talks constantly, annoyingly'; cf. cəssi-nákw-so (bother-look-AI-(3)) 'he is bothersome, a nuisance.' I will argue in 6.4.4 that this peculiarity of cəs-tákw-so results from lexically specified underlying syllabification in the root /cəss-/. (Imperative forms and some absentative forms of cəs-tákw-so are also semantically aberrant, meaning 'be quiet, shut up' rather than 'talk constantly': cəs-tákw-s 'shut (sg.) up!'; cəs-tákw-so-w-à (bother-sound-AI-3-3PROX.ABS) 'he has shut up.')

When syncope of /i/ is retained at the beginning of a medial or final in a position in which syncope is possible, the resulting word looks as if it could have been formed with connective /i/ instead, since the connective vowel is never subject to syncope: /i/ is never deleted before /hC/ in words like h-kísí-hto-n (3-past-TI-3IN) 'he made it' and pécí-hpon (arrive-winter-(3)) 'winter is coming.' In fact it is possible that syncope of /i/ has been reanalyzed as connective /i/ in forms like l-íhkawətó-wək 'they (du.) walk thus' and cków-

ih<sup>h</sup>tákw-ət 'it sounds as if it is approaching.' (Reanalyzing /-ihkawəti-/ and /-ihtakw-/ as /-hkawəti-/ and /-htakw-/ would not result in any change in forms in which one of these morphemes follows a vowel, since unstressable /i/ is deleted after a vowel in any case, as we will see in Chapter 8.) Syncopating /a/ receives the same kind of variable treatment as syncopating /i/, however. Since there is not otherwise a connective /a/ in Passamaquoddy, these cases cannot be the result of the sort of reanalysis which might be suggested where /i/ is involved.

## 6.2 Syncopating /a/

I noted in the last section that non-syncopating /i/ is actually more common than syncopating /i/ in the environment in which the alternating vowel is found. The same situation holds for syncopating /a/: non-syncopating /a/ is more common than syncopating /a/ before /hC/ and /sC/, the environments in which the latter typically occurs. Several examples of non-alternating /a/ in these contexts are given in (29).

- (29) a. ah<sup>h</sup>sósəwən  
           'hat'
- b. ka<sup>h</sup>hsi-hpòt  
           dry-wipe  
           'wipe (sg.) it dry'
- c. ma<sup>h</sup>kwáni-hpók-ət  
           maple.sugar-taste-II-(3)  
           'it tastes sweet'

- d. áskəm-áwso  
 forever-live-(3)  
 'he lives forever'
- e. másp-~~a~~tékan-e  
 thick-skin-AI-(3)  
 'he has thick skin'

Syncopating /a/ in the roots /tahk-/ 'cool,' /tahkikw-/ 'heavy,' /and /tahkw-/ 'arrest' is illustrated in (30)-(32). The stem /tahkw-~~a~~n-ahke-/ 'arrest,' in which /tahkw-~~a~~n-/ TA arrest is combined with an AI final otherwise unknown to me, contains two occurrences of /a/ which are deleted or retained together under alternating stressability, as shown in (33).

- (30) a. n-táhk-ahsəm  
 1-cool-swim  
 'I swim (to cool off)'
- b. tk-áhsemo  
 cool-swim-(3)  
 'he swims (to cool off)'

- (31) a. n-táhkikw-əl  
 1-heavy-AI  
 'I am heavy'
- b. tkikw-əl  
 heavy-AI-(3)  
 'he is heavy'

- (32) a. h-táhk-w-ən-a-l  
 3-arrest-by.hand-DIR-3.OBV  
 'he arrests the other'
- b. tkw-ən-â  
 arrest-by.hand-3PASS  
 'he is arrested'
- (33) a. n-táhk-w-ən-ahkè-pən  
 1-arrest-by.hand-AI-11  
 'we (du. exc.) arrest'
- b. tkw-ən-ke  
 arrest-by.hand-AI-(3)  
 'he arrests'

Both /a/ and /i/ are subject to syncope in tkíkw-té-hsin 'he falls and lands heavily,' from /tahkíkw-ihte-hsin-w/ (heavy-strike-lie-(3)), but syncopting /i/ is not in a position to appear on the surface in any form of this verb.

Deletion or retention of syncopting /a/ varies with prefixation and Initial Change in the root /məsahk-/ 'sorry' and the stem /cəp-ahkatəm-/ 'be married.' The latter is at least etymologically complex: cf. kís-katəm (past-marry-(3)) 'he got married.'

- (34) a. msáhk-éyo  
 ~ psáhk-éyo  
 sorry-AI-(3)  
 'he is sorry about something'



- b. m<sup>́</sup>esk-eyi-n  
 (3)-sorry-AI-PEG  
 'he is sorry about it'
- c. m<sup>́</sup>esk-eyi-t  
 sorry-AI-3AN-(PERF)  
 'when he was sorry about it'

- (35) a. cp-<sup>́</sup>ahkat<sup>́</sup>m  
 ?-married-(3)  
 'he is married'
- b. k-c<sup>́</sup>ap-kat<sup>́</sup>m-<sup>̀</sup>op<sup>́</sup>n  
 2-?-married-11  
 'we (du. inc.) are married'
- c. c<sup>́</sup>ep-kat<sup>̀</sup>-k  
 ?-married-3AN-(PERF)  
 'when he was married'

Syncopating /a/, like syncopating /i/, is replaced by /e/ in Initial Change when it occurs in an appropriate position in a stem: t<sup>́</sup>ehkikw-<sup>̀</sup>al-<sup>̀</sup>ak (heavy-AI-3AN-(PERF)) 'when he was heavy.'

For the most part, deletion and retention of /a/ follows the expected pattern regularly in the final /-ahte-/ 'be located' and in the noun final /-ahki/ 'land.' Thus the /a/ of /-ahte-/ is retained in (36) after a cluster which is not /hC/ and where is strong by alternating stressability. In (37) this vowel is dropped after a stressable vowel and a single C, after /hC/, and where /a/ is unstressable in word-initial /((C)<sup>̀</sup>[+sonorant]<sup>́</sup>a / or by alternating stressability.

- (36) a. sákh-áhte  
 into.view-located-(3)  
 'it protrudes into view'
- b. ihtəl-áhte  
 regularly-located-(3)  
 'it is always there'
- c. áhsəw-əcək-áhte  
 across-messy-located-(3)  
 'it is flopped over to one side'
- (37) a. nis-ék-te  
 two-sheet-located-(3)  
 'it has two layers'
- b. émek-te (/emehk-ah-te-w/)  
 below-located-(3)  
 'it is down below'
- c. cən-te  
 stop-located-(3)  
 'it (a vehicle) is parked'
- d. kwéni ál-cək-te-k (/al-əcək-ah-te-k/)  
 while around-messy-located-3IN  
 'they they (in.) are lying around dirty'

A few examples showing deletion and retention of /a/ in /-ahki/ are given in (38).

- (38) a. wəpən-ahki-k  
 dawn-land-LOC  
 'Wabanaki territory (loc.)'

- b. lá<sup>h</sup>m-ki-k  
 inside-land-LOC  
 'hell (loc.)'
- c. spám-ki-k  
 above-land-LOC  
 'heaven (loc.)'

The stem /sán-ahte-/ (thick-located) 'be tight' appears to be a special case. Even my oldest consultants seem to prefer sán-ahte 'it is tight' and sén-ahte-k 'that which is tight,' where the /a/ of /-ahte-/ is unexpectedly stressable, to the expected forms sán-te and sén-te-k, although these are also acceptable.

Both /-ahte-/ and /-ahki/ correspond to initial elements which are synchronically irregular. Thus we have ate 'it is located,' but ehte-k 'where it is.' Etymologically related to /-ahki/ there is kihke 'he plants,' with prefixed forms variably based on a stem /-ahkihke-/ or /-ahkihke-/ and Changed forms showing a stem /ekihke-/: nt-ahkih 'I plant,' ht-ahkihka-n 'he plants with it (e.g. with seed potatoes),' ekihke-t 'when he plants.' Note also the noun kihkan 'garden,' possessed ht-ahkihkan 'his garden.'<sup>4</sup> These forms appear to reflect a sound change by which \*h was lost between a word-initial short \*a and a consonant. (In this connection note also akwám 'louse,' possessed ht-ahkwám-al 'his louse.')

This sound change has not been retained in its original form as a phonological rule, but a number of stems in which alternations like the following are found suggest that there may

be a synchronic rule which deletes word-initial /h/ before a consonant after /a/ is dropped in syncope.

(39) a. kóhk

'buttocks'

b. ht-áhkóhk-əl

3-buttocks-3.OBV

'his buttocks'

(40) a. tóh-pe (/ahtəw-əpe-w/?)

through-liquid-(3)

'it (an.) contains liquid

b. ht-áhtóh-pa-n

3-through-liquid-SUBORD

'it (an.) contains liquid (Subordinative)'

c. éhtoh-pe-t

through-liquid-3AN-(PERF)

'when it was full'

(41) a. síhpil-a-t

give.medicine-DIR-3AN-(SUBJ)

'if he gives the other medicine'

b. ht-áhsíhpil-a-l

3-give.medicien-DIR-3.OBV

'he gives the other medicine'

c. éhsíhpil-a-t

give.medicine-DIR-3AN-(PERF)

'when he <sup>a</sup>gve the other medicine'

- (42) a. ców-y-â  
 hire-TA-3PASS  
 'he is hired'
- b. ht-âhców-y-a-l  
 3-hire-TA-DIR-3.OBV  
 'he hires the other'
- c. éhcow-y-òt  
 hire-TA-3PASS-(PERF)  
 'when he was hired'

There is a great deal of variation in words of this type, however, suggesting that several kinds of reanalysis have been taking place. The forms cited in (40) are consistent with an underlying form /ahtəw-/ for the root 'through, in or out of an opening,' which is also supported by forms like nt-áhtəwá-ssəmi-n (1-through-drink-PEG) 'I drink from it.' But alongside nt-áhtəwá-ssəmi-n we have n-towá-ssəmi-n; alongside ht-áhtóh-pa-n we have h-tóh-pa-n. Compare also éhtoh-pè-t 'when it was full' and tew-álək-ət-ə-k (through-hole-eat-TI-3AN-(PERF)) 'when he ate into it.' In these forms we find support for an alternative underlying form /təw-/. Similar variation is attested for the stem of the verb 'hire': the forms cited in (42) suggest underlying /ahcowi-y-/ or the like, but alternate forms like h-ców-y-al 'he hires the other' and ców-y-òt 'when he was hired' suggest /cowi-y-/ instead. Alternations in the stem of 'feed' have fallen even further into disarray: nt-áhsəm-a ~ n-səm-a (1-feed-DIR) 'I feed him,' éhsəm-à-t ~ áhsəm-à-t ~ səm-à-t (feed-DIR-3AN-(PERF)) 'when he fed the other.' For my oldest

consultants, the preverb 'must, need' usually has the unprefixes stem cowi, the prefixed stem -ahcəwi, and the Changed stem ehcəwi. My youngest consultants instead use cowi and tahcəwi interchangeably in all paradigms, having abandoned ehcəwi altogether. (Presumably tahcəwi reflects a recutting of prefixed forms with -ahcəwi. The t now occurs freely in unprefixes forms.)

Clearly such massive variation calls into question the synchronic status of a rule deleting initial /h/ in syncopated forms. We may simply be dealing with morphologically governed stem allomorphy here. In any case, it is clear that a rule deleting initial /h/, if there is one, must precede the change of /n/ and /w/ to /h/ which results from Initial Devoicing, since /h/ which arises through the latter process may be retained on the surface.

In some nouns, stem-initial /ah/ has apparently been reinterpreted as a kind of augment which is used in conjunction with the personal prefixes to make possessed forms. For təp 'bow,' for example, we find both h-təpi-yil and ht-áh-təpi-yil 'his bow.' Here /-ah-/ is etymologically correct in the possessed form, since Passamaquoddy təp represents PA \*a?ta?pya (Warne (1977a:21)). As an augment, however, this /-ah-/ has now been extended to stems in which it did not originally occur, and even to borrowings: h-sókəl-ís-m ~ ht-áh-sókəl-ís-m (3-AUG-sugar-DIM-POSS) 'his candy.' h-tí-m ~ ht-áh-ti-m (3-AUG-tea-POSS) 'his tea.' Possibly the initial /ah/ found with /təw-/ 'through' should be interpreted as the augment when this root occurs in nouns: n-tów-ápowá-kən ~ nt-áh-təw-ápowá-kən (1-AUG(?)-through-

drink-NOM) 'my cup'; cf. taw-ápowá-kən 'cup.' In any case, it may be through analogy with forms like these that an augment with the shape /-aht-/ has come into use with nouns like wík-hí-kən (write-TA-NOM) 'book' whose stems begin with / w/: ht-ówik-hí-kən ~ ht-áht-áwik-hí-kən 'his book.' Again it is clear that several kinds of reanalysis have been taking place.

The type of reanalysis that we see in words like n-sám-a 'I feed him' and h-tápi-yil 'his bow,' where initial /ah/ has been eliminated from the stem, is common even among the oldest speakers. Middle-aged and younger speakers use or accept many forms which reflect reanalysis of stem-internal occurrences of syncope /a/. Most frequently, syncope /a/ is simply reinterpreted as a non-alternating, inherently stressable vowel. Thus we find táhkáhsamo 'he swims to cool off' and tákwánáke 'he arrests' alongside tkáhsamo and tkwánke. But some speakers now have two full sets of forms for the verb cpáhkátəm 'he is married,' one based on the unprefix stem cpahkatəm-, the other on the prefixed stem capkat m-. (Not surprisingly, the prefix is usually dropped in forms like ncpáhkátəm 'I am married' and kcpáhkátəmòpən 'we (du. inc.) are married,' since retention of the prefix consonant in such forms produces anomalous initial clusters.) Clearly there is little sense in speaking of a stem /capahkatəm-/ for such speakers.

Several II finals which otherwise appear with surface ət or ən have allomorphs with ah instead before the third person Conjunct suffix /-k/. The /a/ of these finals is optionally subject to syncope, under appropriate conditions. Presumably here as above syncope represents the original treatment in such

cases, while retention of /a/ where syncope would be possible reflects leveling; but forms with retained /a/ are used by speakers of all ages.

Allomorphy before /-k/ is illustrated for the final /-ət-/ and /-ən-/ in (43)-(45) and for the /-əkikhwən-/ 'be a size' in (46). Compare the treatment of /-kən-/ 'be, become of a kind or nature,' shown in (47). Here /ən/ is not replaced by /-ah/. Nasal Deletion, another morphologically governed rule, is applied instead, so that /-kən-/ appears as -kə- before -k.

- (43) a. wəli-nák-w-ət  
 good-look-II-(3)  
 'it looks good'
- b. wəli-nák-w-ah-k  
 good-look-II-3IN  
 'that which looks good'
- (44) a. skət él-ənok-ət-ónohk  
 not thus-event-II-3.IN.NEG  
 'that which does not happen'
- b. él-ənók-ah-k  
 thus-event-II-3IN  
 'that which is happening'



- (45) a. tkíkw-ən  
heavy-II-(3)  
'it is heavy'
- b. téhkík-ah-k  
heavy-II-3IN  
'that which is heavy'
- (46) a. kíń-kíhk<sup>í</sup>w-ən  
large-size-(3)  
'it is big'
- b. kíń-kíhk<sup>í</sup>w-ah-k  
large-size-3IN  
'that which is big'
- (47) a. wəlí-kən  
good-kind-II  
'it is good (for use)'
- b. wəlí-kə-k  
good-kind-3IN  
'that which is good (for use)'

Syncope, and the optionality of syncope, is illustrated in (48)-(50). In (49a) and (50b), syncope is possible because the Subjunctive and Perfective affixes consist of an empty V-slot. Several of these examples show the loss of /h/ before clusters and between non-syllabics in addition to syncope of /a/. Intermediate /kwk/ is converted to /kwkw/ by geminate formation.

- (48) é1-ənok-k-əp n  
 thus-event-3IN-PRET  
 'that which happened'
- (49) a. wəli-nakw-kw  
 ~ wəli-nakw-ah-k  
 good-look-II-3IN-(SUBJ)  
 'if it looks good'
- b. wəli-nakw-kw-əsəpən  
 ~ wəli-nakw-a-k-səpən  
 good-look-II-3IN-DUBIT-(SUBJ)  
 'if it had looked good'
- (50) a. kɪn-kikw-kw-il  
 large-size-3IN-33IN  
 'those (in.) which are big'
- b. téhkikw-ah-k  
 heavy-II-3IN-(PERF)  
 'when it was <sup>heavy</sup>big'

Although the schwas of /-ət-/, /-ən-/, and /-əkihkw n-/ are underlyingly unstressable vowels, the /a/ of their allomorphs with /ah/ is optionally treated as an inherently stressable vowel.

The alternation of a with zero before sC is maintained most consistently in a few non-initial elements, notably in the medial /-askot-/ 'field,' as shown in (51). As is so often the case, however, there are signs of leveling: forms like those in (52) in which /a/ is maintained where syncope would be possible.

- (51) a. áps-askót-e  
 small-field-II-(3)  
 'it is a small field'
- b. nátam-askót-e  
 fairly.big-field-(3)  
 'it is a fairly big field'
- c. álam-askót-e  
 away-field-II-(3)  
 'there is a long field'
- d. kín-skót-e  
 large-field-II-(3)  
 'it is a big field'
- e. pám-skót-e  
 along-field-II-(3)  
 'there is a field'
- (52) a. épahs-askot-è-w  
 half-field-PART-PART  
 'right in the middle of a field'
- b. səw-askot-è-w  
 middle-field-PART-PART  
 'out in the middle of a field'

Matters are considerably more complicated where syncopating /a/ is found in stem-initial /asC/. Some stems show the expected pattern sC ~ -asC ~ esC, but often there are competing forms with non-alternating sC or asC, and some stems optionally alternate in the pattern sC ~ -osC ~ wesC which is historically proper to stems in underlying /wəsc/.

The root sp- 'up high' has forms like those shown in (53) which suggest underlying /asp-/, but examples of doublets like (54) suggest that some speakers may also employ underlying /sp-/.

(53) a. sp-ék-əpo

high-sheet-sit-(3)

'it (an., sheet-like) is high up;

he is high up (physically or bureaucratically)'

b. nt-ásp-ek-əp

1-high-sheet-sit

'I am high up'

c. ésp-ék-əpi-t

high-sheet-sit-3AN-(PERF)

'when he was high up'

(54) nt-ásp-əp

~ n-sp-əp

1-high-sit

'I sit up high'

The a of the root askow- 'wait' alternates with zero when this morpheme occurs as part of a complex final, but I have recorded only forms with retained a where askow- begins a stem:

(55) a. h-sípk-asków-y-a-l

3-long.time-wait-TA-DIR-3.OBV

'he waits for the other for a long time'

b. h-síw-sków-y-a-l

3-tired-wait-TA-DIR-3.OBV

'he is tired of waiting for the other'

- c. askow-h-i-n  
 wait-TA-1.OBJ-2  
 'wait (sg.) for me!'

For the root spate- 'during the day,' we find both forms with -aspate- ~ espate-, suggesting underlying /aspate-/, and forms with -ospate- ~ wespate-, suggesting /waspate-/. This kind of variation is common in noun stems in which syncope of /a/ is attested. The nouns shown in (56)-(58) all have possessed forms with stem-initial a, but prefixed forms made on the pattern for stems in initial /w / are also attested for (58).

- (56) a. skwehsamohs  
 'bitch'  
 b. ht-askwehsamohs-am-al  
 3-bitch-POSS-3.OBV  
 'his bitch'
- (57) a. stahkwon  
 'fir (Indian Twp.), tree (Pleasant Pt.)'  
 b. ht-astahkwon-om-1  
 3-fir/tree-POSS-3.OBV  
 'his fir, his tree'
- (58) a. skwat  
 fire  
 b. ht-askwate-m  
 ~ oskwate-m  
 3-fire-POSS  
 'his fire'

Note also that stem-initial a in these forms might be taken as a reflex of the possessive augment /-ah-/, since underlying /h/ would be deleted before /sC/ by H-Deletion III.<sup>5</sup>

There are a few morphemes in which syncoating a is not followed on the surface either by hC or by sC. Possessed forms of pkəsən 'shoe' are based on a stem -maksən: k-maksən-əl (2-shoe-3.OBV) 'your (sg.) shoe (obv.).' The corresponding medial takes the forms -kəsən- and -aksən-, with -kəsən- occurring after consonant-final roots without the use of connective /i/, suggesting the presence of an underlying initial vowel: kín-kəsən-e (large-shoe-AI-(3)) 'he has big shoes,' pós-kəsən-e (wet-shoe-AI-(3)) 'he has wet shoes,' pkw-aksən-e (red-shoe-AI-(3)) 'he has red shoes.' As usual, however, a sometimes surfaces as a stressable vowel where syncope is expected: kín-aksən-e (large-shoe-AI-(3)) 'he has big shoes.'<sup>6</sup> If /makəsən/ is the underlying form of the noun 'shoe' and /-akəsən-/ is the underlying form (or an underlying form) of the medial, then syncoating /a/ is in an anomalous underlying environment in these elements as well as in an exceptional surface context. On the other hand, if the underlying forms are /mahkəsən/ and /-ahkəsən/, then /h/ is deleted in all occurrences of these morphemes.

A similar problem of analysis arises in the case of the medial -atak- ~ -tak- 'string-like object, line.' Here again we seem to have syncoating /a/ where there is no direct evidence for a following /h/: ks-átak-ihté-hsin (intense-line-strike-kie-(3)) 'it (an., string-like) strikes, ponds against something,' əl-ták-te (thus-line-located-(3)) 'it (e.g. a wire) is set in a direction.' As before, however, /a/ may be retained

where syncope is possible: l-átak-áhte 'it is set in a direction.' For this medial, we might set up underlying /-ahtək-/: H-Deletion IV would always delete /h/ in this morpheme whenever /a/ is retained, since the following /ə/ would be unstressable in such cases. Application of H-Deletion IV after a site where a vowel alternates in syncope would, however, be unique to this morpheme. We will see below that an analysis of syncopating /i/, /a/, and /o/ within the CV theory of stressability will allow us to give a phonological account of syncope in morphemes like -aksən- and -atak- without postulating abstract occurrences of /h/. The fact that alternations involving these morphemes are not consistently maintained suggests, however, that speakers may in any case have abandoned a phonological analysis of the distribution of their alternants.

### 6.3 Syncopating /o/

Syncopating /o/ occurs only in a few morphemes. The principal example is the medial /-ohkwe-/ 'body,' shown in (59) first in its full form and then with loss of /o/:

- (59) a. sákh-ohkwé-po  
 into.view-body-sit-(3)  
 'he sits, protruding into view'
- b. nt-ásp-ohkwè-p  
 1-high-body-sit  
 'I sit up high'

- c. sásak-ohkwé-po  
 bent(?)—body—sit—(3)  
 'he half stands, half sits, leaning  
 against something'
- d. ál-kwé-po  
 around—sit—(3)  
 'he sits around'
- e. ékw-kwé-po  
 stop—body—sit—(3)  
 'he stops being able to sit up'
- f. ckóh-kwé-po  
 hither—body—sit—(3)  
 'he sits facing this way'
- g. ál-kwé-po  
 thus—body—sit—(3)  
 'he sits thus'

The form álám-ohké-po (away—body—sit—(3)) 'he sits facing away,' with -ohke- in place of -ohkwe-, suggests that the original alternation in 'body' was between -kwe- and -ohke-. The form -ohkwe- would then represent a leveling out of the alternation between k and kw in this morpheme.<sup>7</sup>

An alternation between o and zero was maintained until recently in the inflection of the noun kísohk 'day.' This singular form is recorded as "kisook" in J.D. Prince (1897:482) and is confirmed for Woodstock Maliseet by Peter Paul;<sup>8</sup> but only certain inflected forms, all with syncope, are still current in Passamaquoddy: kísk-ol 'days,' h-kísk-om 'his day.' Maliseet



kiskw 'yesterday' perhaps represents the absentative singular of this noun. The o of atóhk 'deer' must also have alternated at one time in a similar fashion, since some speakers have ht-át-k-óm-əl 'his buck' alongside ht-átóhk-am-əl 'his deer.'

There is one other morpheme in which /o/ sometimes appears to be subject to syncope in the contemporary language. The final with the general meaning 'hunt, gather, acquire' appears as -ke- after a non-syllabic in contexts permitting syncope: áhkikw-s-ís-ke (seal-DIM-DIM-acquire-(3)) 'he hunts pub seals,' piyéw-ke (beer-acquire-(3)) 'he makes beer.' After a stem ending in a vowel, we find -hke-: mówine-hke (bear-acquire-(3)) 'he hunts bear,' wikpi-hke (brown.ash-acquire-(3)) 'he gathers brown ash'; cf. mówine-kk 'bears (abs.),' n-wikpi-m 'my brown ash.' Both sets of examples are consistent with an underlying form for 'acquire' with an initial unstressable vowel, since an unstressable vowel is deleted after another vowel.

Sherwood (1983b:33) sets up underlying /-əhke-/ for 'acquire,' which, given his analysis, should yield surface -ihke- where no deletion takes place. And indeed there are a few examples with -ihke-: piyakwtíhikən-ihke 'he gathers wood chips' cf. piyakwtíhikən 'wood chip.' But more often we find -ohke-: piyakwtíhikən-ohke 'he gathers wood chips,' típs-ohke 'he gathers spruce tips' (with English tips). It is possible, then, that this final has come to be interpreted as underlying /-ohke-/, with syncope of /o/. As usual, though, there are forms with a non-alternating vowel which cloud the issue: piwsək-ohke 'he gathers firewood'; cf. piwsək 'firewood.' In fact, such formations are common.

#### 6.4 Extending the CV theory of syncope

My purpose in this section is to show how the analysis of syncopating ə which was developed in Chapter 5 can be extended to account for syncopating i, and a and o. It may be appropriate at the outset, however, to ask how much of the data we should expect to cover in a phonological analysis of alternations like those described in the preceding sections. Some vowel/zero alternations which are historically cases of syncope should undoubtedly be stated as morphologically conditioned allomorphy in the synchronic grammar of Passamaquoddy.

Consider, for example, the noun pəkáhkən 'blood.' On the basis of possessed forms like h-pəkán-om (3-blood-POSS) 'his blood,' we are led to set up an underlying stem for pəkáhkən in which /a/ may be subject to syncope if it remains unstressable under alternating stressability. We can test the hypothesis that there is such a stem by looking at verbs which are derived from this noun, such as pəkáhkən-ék-ən (blood-sheet-II-(3)) 'it (e.g. cloth) is bloody.' By hypothesis, /a/ is retained in this form because it is in second position in a series of vowels /ə...a...ə/ within which alternating stressability holds. Under Initial Change, the first vowel of this series is excluded, since it is replaced by inherently stressable /e/. This leaves /a/ in first position, where it should be subject to syncope. But it is not: /a/ is always retained in pəkáhkən-ék-ə-k (blood-sheet-II-3IN) 'that (e.g. cloth) which is bloody.'

The stem /pəkáhkən-ihte-h-/ TA 'strike, drawing blood' is formed with the medial /-ihte-/ 'strike,' in which /i/ may

undergo syncope. In the reciprocal form pəkáhkən-íhto-h-ót-oltó-w-ək (blood-strike-TA-RECIP-PL-3-33PROX) 'they (pl.) hit one another, bloodying one another,' this stem is used without a prefix. Both /a/ and /i/ are predictably retained on the surface, since by hypothesis alternating stressability holds in /ə...a...ə...i/, and /a/ and /i/ are in even-numbered positions in this series of vowels. When the TA stem is used with a prefix, the first /ə/ of /pəkáhkən/ follows a cluster and will not figure into alternating stressability. Thus we predict syncope of /a/ and /i/ in such cases, since these vowels are now first and third in /a...ə...i/. Again the prediction is wrong: h-pəkáhkən-ihtá-h-a-l (3-blood-strike-TA-DIR-3.OBV) 'he hits the other, bloodying him.' From this evidence, it seems reasonable to conclude that the /a/ of pəkáhkən is inherently stressable. Since underlying /pəkáhkən/ with unstressable /a/ would apparently occur only in possessed forms, it seems more economical to set up underlying /-pəkkən-/ for these: we must posit an irregular possessed stem in either case. Of course, if we take this position then we might expect to find possessed forms based on the independent stem /pəkáhkən/. And indeed we do: h-pəkáhkən-om 'his blood' is a fully acceptable alternative to h-pəkkən-om, apparently for all speakers.

On the other hand, it seems reasonable to speak of phonological syncope where vowel/zero alternations are maintained quite regularly under prefixation and Initial Change, as in ksihka- ~ -kəska- ~ keska- 'lose,' or where the absence of connective /i/ implies the underlying presence of a syncoating

vowel, as in kis-te 'it is finished,' from /kis-ahte-w/  
(finished-located-3).

The discussion which follows is based on the premise that there is at least a core of cases of syncope-like alternations of i, a, and (perhaps) o which should be analyzed as phonological syncope. It is entirely consistent with this hypothesis to suppose that numerous alternations in particular morphemes have been reinterpreted as non-phonological allomorphy. Clearly the number of alternations for which a phonological analysis can be motivated is much lower for the language of the youngest speakers than it is for the language of their grandparents.

To the extent that they continue to be phonological in character, the alternations discussed in sections 1-3 are easily accommodated within the rest of the system of Passamaquoddy phonology by setting up underlyingly unstressable /i/, /a/, and /o/ for surface i, a, and o which participate in syncope. Within the CV framework for the analysis of stressability, this means setting up syncoating /i/, /a/, and /o/ as underlying floating vowels. Alternative accounts could certainly be developed within the diacritic and metrical theories of stressability, but there does not appear to be any reason to think that either of these approaches would lead to a superior analysis. Arguments against an analysis of a more abstract character are presented in the following section.

I begin in 6.4.1 by formalizing the rule of H-Deletion V, which deletes /h/ in the output of syncope where a vowel is dropped before /hC/. The remainder of the present section shows

how the analysis of Chapter 5 can be extended to cover syncope of i, a, and o.

#### 6.4.1 H-Deletion V

When syncope results in a cluster of the form /ChC/, /h/ is deleted by a rule which we may formalize as follows:

(60) H-Deletion V

$$\begin{array}{c} C \\ | \longrightarrow \phi / C \underline{\quad} C \\ h \end{array}$$

There are two reasons to believe that /h/ is actually deleted in this environment, and not just phonetically unrealized in some other sense. First, there is no phonetic distinction between CC from /ChC/ and CC from other sources: the kt of ktám-at-à-k (disinclined-TI-TI-3AN-(SUBJ)) 'if he does not feel like doing it' is not distinct from the kt of ktámak-éyo (poor-AI-(3)) 'he is poor,' although the former is derived from /kiht/ and the latter from /kət/; cf. n-kiht-am-at-am-an 'I do not feel like doing it,' n-kótamak-éy 'I am poor.' In both cases, t is phonetically lax after k, although t is generally tense in ht. Second, the underlying presence of /h/ does not block the application of Geminate Deletion in clusters derived from /ChC/. This is particularly clear in cases involving /kw/. Surface /kwkw/ is [k w] in wikw-kwat (take(?)-ebb-(3)) 'the tide goes out' (underlying /wihkw-ihkət-w/) and ékw-kwé-po (stop-body-

sit-(3)) 'he stops being able to sit up' (underlying /ehkw-ohkwe-əpiw/), showing that Geminate Deletion and Leftward Spreading have applied here as in other geminate clusters.

If the loss of woprd-initial /h/ after the deletion of a preceding /a/ is still to be regarded as phonological, then we will need a rule with the following effect:

$$(61) \begin{array}{l} C \\ | \text{ ---> } \emptyset / \# \text{ \_\_\_\_\_\_ } C \\ h \end{array}$$

Presumably such a rule could be collapsed with H-Deletion V as follows:

$$(62) \text{ H-Deletion V (generalized)}$$

$$\begin{array}{l} C \\ | \text{ ---> } \emptyset / \left\{ \begin{array}{c} C \\ \# \end{array} \right\} \text{ \_\_\_\_\_\_ } C \\ h \end{array}$$

#### 6.4.2 Generalizing the syncope rules

Consider first the case of syncope before /sC/. Since /a/ and /ə/ are the only syncope vowels which occur in this environment, they are also, by hypothesis, the only floating vowels which occur here. Accordingly, all that we have to do to allow for syncope before /sC/ is to generalize Schwa Deletion I so that it will delete any floating vowel before an obstruent, not just floating /ə/. This change in the statement of the rule in fact constitutes a simplification, since the

target can now be specified simply as [-consonantal]; more features are required to restrict the rule to floating vowels of a particular quality. If we use the symbol "v" as a notation for [-consonantal], the generalized version of Schwa Deletion I may be stated as follows:

(63) Syncope I

$$\textcircled{v} \rightarrow \emptyset / \text{ \_\_\_ } [-\text{sonorant}]$$

Syncope I will delete the /a/ of /-askot-/ 'field' in kín-skót-e (large-field-II-(3)) 'it is a big field, ' just as it deletes the /ə/ of /m sk-/ 'find' in psk-əm-an (find-TI-1-(SUBJ)) 'if I find it.' The syllabified underlying form of kínskóte, ignoring the suffix, is (64a). Since floating /a/ precedes an obstruent here, it is deleted, giving (64b). Syllabification of /s/ by the late rule which incorporates this rule into a following syllable ultimately completes the derivation.

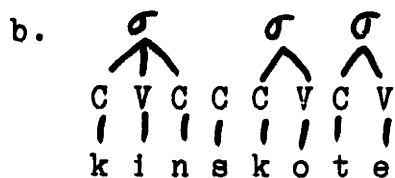
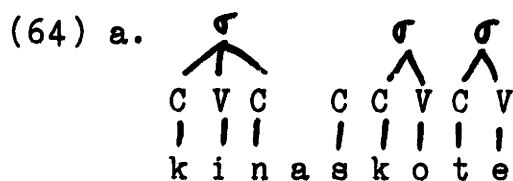

The simplest way to allow for the deletion of unstressable /i/, /a/, and /o/ before /hC/ is to generalize Schwa Deletion II in a parallel fashion:

(65) Syncope II

Ⓟ ---> ø / \_\_\_ h

This rule will delete any floating vowel before /h/. All of the Passamaquoddy vowels except /e/ have floating counterparts in this environment.

Of course this solution would in principle also permit syncope before /hC/ where C is a sonorant, and no cases of this kind are attested. It is not clear that a linguistically significant generalization is involved here, however. All of the h-sonorant clusters of Passamaquoddy are rare in underlying forms, and all appear to be historically the result of syncope. In any case, it would be easy to restrict syncope before /hC/ to cases in which C is an obstruent by modifying Syncope I instead of Schwa Deletion II so that it would carry out the required deletions. We would only need to allow for an optional /h/ in the structural description of Syncope I, as shown in (66).

(66) Ⓟ ---> ø / \_\_\_ (h) [-sonorant]

Since this move requires us to complicate our analysis, however, and since no significant empirical issues appear to be involved, I will adopt (65) instead.

Given the hypothesis that syncoating /i/, /a/, and /o/ are underlying floating vowels, Syncope II will correctly account for deletion in forms like kis-kət (past-ebb-(3)) 'it is low tide,' émek-te (below-located-(3)) 'it is down below,' and ékw-kwé-po (stop-body-sit-(3)) 'he stops being able to sit up.'



The first of these forms has the representation shown in (67a) after the application of Final Syllable Epenthesis. Syncope II derives (67b), from which H-Deletion V gives (67c).

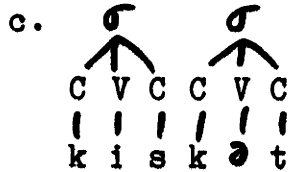
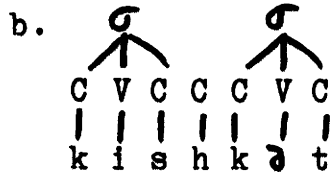
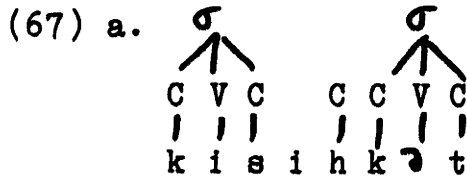

The syllabified underlying form of émék-te is (68a). (For /hk/ in /emehk-/, cf. émehkèw 'down below, downstairs.') Syncope II yields (68b), a structure to which both H-Deletion III and H-Deletion V are applicable. Their output is (68c).

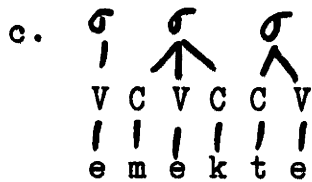
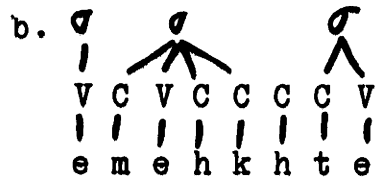
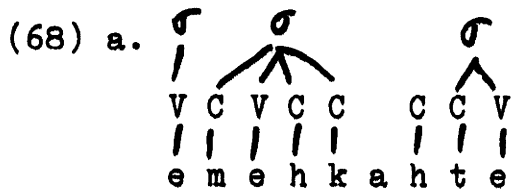

After the application of Final Syllable Epenthesis, (69a) is the representation of ék-w-kwé-po. Syncope II gives (69b), H-Deletion II and H-Deletion V give (69c), and Geminata Deletion followed by Leftward Spreading gives (69d). Word-final /əw/ is realized as o, and /ə/ is deleted after /e/ by Vowel Elision, so that we ultimately derive (69e).

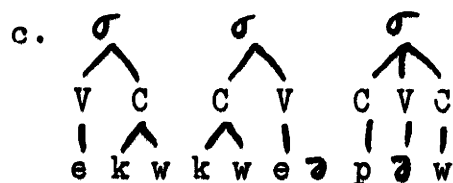
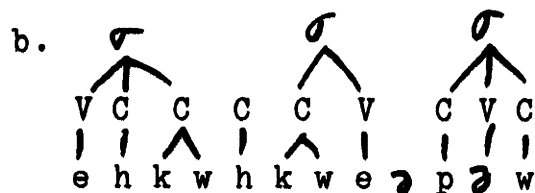
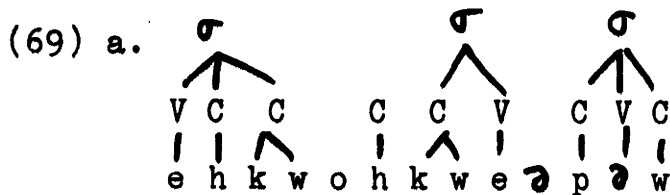

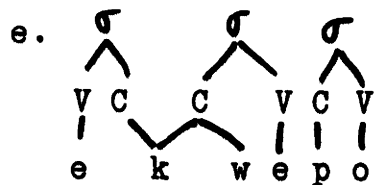
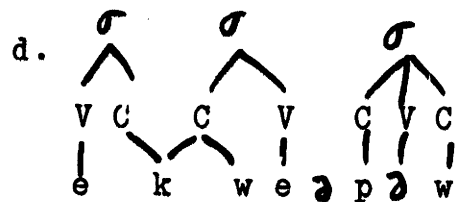

Within this framework, the retention of syncopating /i/, /a/, or /o/ where deletion is expected can be seen as the result of reanalysis of an underlying floating vowel as an underlying full vowel, one which is linked with a V-slot. It follows that any /i/, /a/, or /o/ which is retained where syncope would be permitted will be treated as stressable. This prediction is correct.

### 6.4.3 V-Epenthesis

If we generalize V-Epenthesis as well as Schwa Deletion I and Schwa Deletion II so that it will apply to any floating vowel, then we can use this rule to account for the effects of clusters on syncope of underlyingly unstressable /i/, /a/, and /o/ and to accommodate the participation of these vowels in the assignment of alternating stressability. V-Epenthesis is modified as required in (70).

(70) V-Epenthesis (generalized)

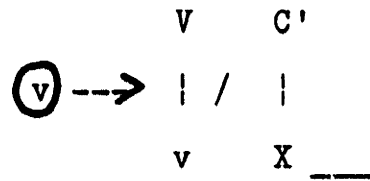

(Left-to-right iterative)

Given (71a) as the underlying form of sákh-áhte (into.view-located-(3)) 'it protrudes into view,' the /h/ of /sakh-/ cannot initially be syllabified. Generalized V-Epenthesis will therefore insert a V-slot after the C associated with this segment, since there is a floating /a/ in this position. Once the /a/ of /-ahte-/ is associated with a V-slot, it cannot be deleted by Syncope II.

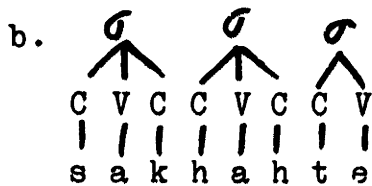
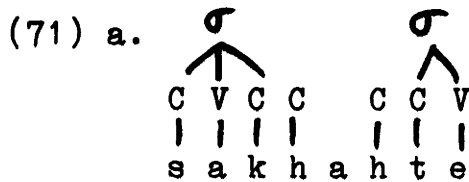

Thus we have an explanation for the contrast between émék-te, with syncope after /hk/, and sákh-áhte, with retention of /a/ after /kh/: the cluster /hk/ can be fully syllabified with a preceding vowel; the cluster /kh/ cannot.

The role of generalized V-Epenthesis is determining alternating stressability can be observed by comparing the derivations of áhsaw-əcək-áhte (across-messy-located-(3)) 'it is

flopped over to one side' and (kwéni) á-l-cák-te-k (while around-messy-located-3IN) '(while) they (in.) are lying around dirty.'

The syllabified underlying representation of the first of these examples is (72a). The first application of generalized V-Epenthesis gives (72b); the second yields (72c).

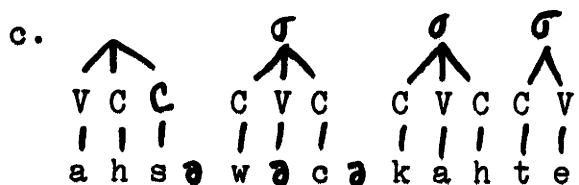
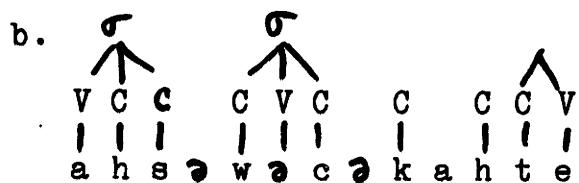
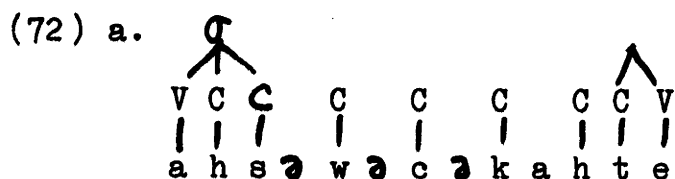

The resulting structure is the input to stress assignment: both the first /ə/ of /-əcək-/ and the /a/ of /-ahte-/ are stressable, but only the latter receives stress by the Alternating Stress Rule. The second /ə/ of /-əcək-/ was noted in 5.2.7 as an exception to Schwa Deletion I. In the terms of the present discussion, this vowel must be marked as an exception to Syncope II. Since no vowel in (72c) undergoes syncope, Schwa Support and resyllabification convert this structure into (73), the correct surface representation for áhsw-əcək-áhte.

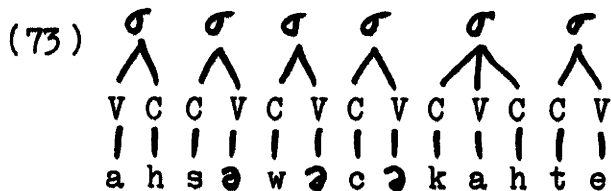

The syllabified underlying representation of ál-cək-te-k is (74a). Here generalized V-Epenthesis is applicable only once, since the only C-slot which remains unsyllabified in (74b) is not followed by a floating vowel. The first /ə/ of /-əcək-/ is deleted by Syncope I, while the /a/ of /-ahte-/ is eliminated by Syncope II. The resulting structure is (74c).

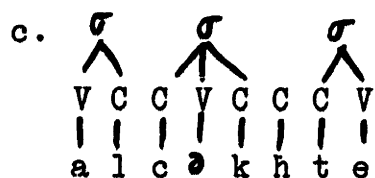
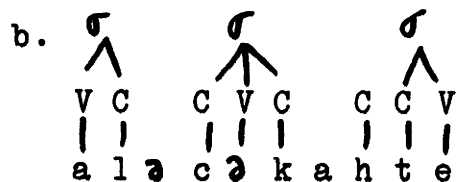
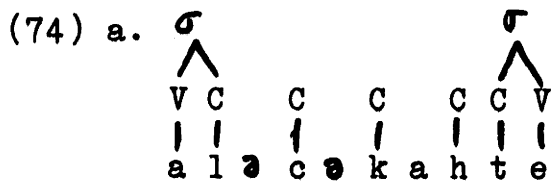

H-Deletion V then deletes the /h/ of /-ahte-/ to derive the correct surface form.

In these examples with /-ahte-/, syncopating /a/ occurs as the last vowel of a series within which alternating stressability holds. Syncopating /i/, /a/, and /o/ can also participate in alternating stressability in initial or medial positions in such a series. The role of generalized V-Epenthesis in these cases

can be seen by comparing the derivations of nát-ków-a-l (go-by.body-DIR-3.OBV) 'he goes right to the other' and ht-áhsəw-íhkəw-a-l (3-across-by.body-DIR-3.OBV) 'he covers the other with his body.'

The underlying representation of nát-ków-a-l is (75a), after /-ə1/ 3.OBV is reduced to /-1/. Because both of the vowels of /-íhkəw-/ are underlyingly unstressable, neither C of the cluster /hk/ in this final is initially syllabified. The first of these slots is not a potential target of V-Epenthesis, but the second is. Application of this rule derives (75b). Syncope II and H-Deletion V give (75c). Extrasyllabic initial /w/ is removed by W-Deletion (5.3.6) and stressable /ə/ is realized as o before w.

(75) a.

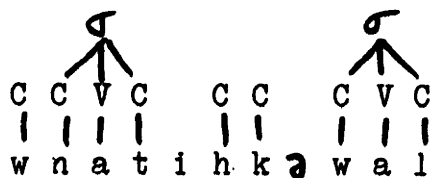

b.

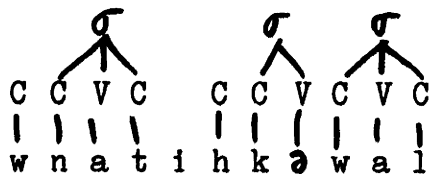

c.

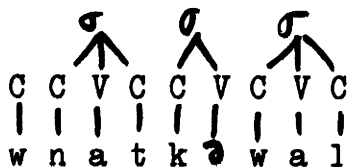

The underlying form of ht-áhsəw-íhkəw-a-l is (76a). The leftmost unsyllabified C-slot here which is followed by a floating vowel is the one which is linked to the /w/ of /áhsəw-/. This C' triggers V-Epenthesis, giving (76b).

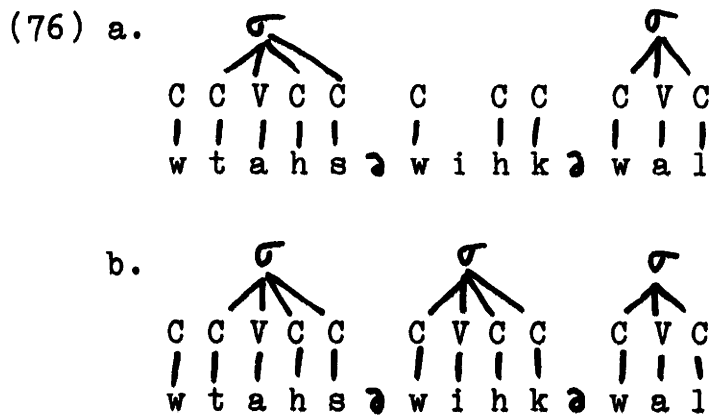

The /i/ of /-ihkəw-/ is now associated with a V-slot, so it is stressable. Because both segments in the cluster /hk/ can be syllabified with this vowel, V-Epenthesis does not apply again, and the /ə/ of /-ihkəw-/ remains unstressable. Stress is assigned to the initial and penultimate syllables of (76b). The result is antepenultimate stress in ht-áhsəw-íhkəw-a-l after Schwa Support converts (76b) to (77).

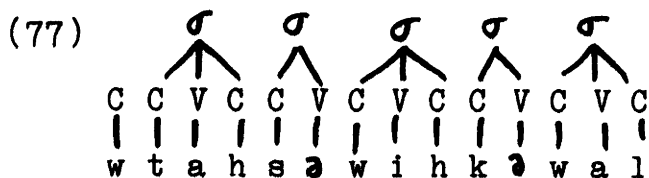

Initial Devoicing gives h for extrasyllabic initial /w/.

#### 6.4.4 Idiosyncrasies in underlying syllabification?

As I noted in 6.1, /i/ is subject to syncope after /ss/, contrary to our expectations, in the verb cás-tákw-so 'he talks constantly, annoyingly,' apparently from /cəss-ihtakw-əsi-w/ (bother-sound-AI-(3)). We do not want to say that the stem of this verb is unanalyzable, since /cəss-/ and /-ihtakw-/ may be



separated to make intensive pejorative forms, even when the stem has the shifted meaning 'shut up': corresponding to cás-tákws 'shut (sg.) up!' we have cáss-<sup>w</sup>alike-htakw-s 'shut (sg.) up, damn it!' (the latter with regular loss of unstressable /i/ after a vowel). Ordinarily, however, an underlyingly unstressable vowel becomes stressable after a geminate cluster, as does the /i/ of /-ihk<sup>w</sup>-/, for example, in ht-áss-ihk<sup>w</sup>-a-1 (3-meet-by.body-DIR-3.OBV) 'he meets the other.'

In 5.2.12, apparent cases of syncope after /pp/ in derivatives of /k<sup>w</sup>pp-/ 'close' were shown to result from the existence of an alternate form /k<sup>w</sup>p-/, with non-geminate /p/. An analysis in terms of non-phonological stem allomorphy was suggested for cases of apparent syncope after /ss/ in inflected forms of /esk<sup>w</sup>tas<sup>w</sup>ss<sup>w</sup>k/ 'cucumber.' Neither type of account is available, however, in the analysis of cás-tákws-so: /c<sup>w</sup>ss-/ 'bother' consistently shows up with /ss/ where it precedes a vowel, and we would expect connective /i/ to be used after /c<sup>w</sup>ss-/ before an underlyingly consonant-initial allomorph of /-ihtakw-/. Nor can we derive the /<sup>w</sup>ss/ of /c<sup>w</sup>ss-/ from /ihs/, after which underlyingly unstressable /i/ could remain unstressable. The Changed form of /c<sup>w</sup>ss-/ is /cess-/, showing that /ss/ is basic in this root: céssi-nákws-si-t (both-look-AI-3AN) 'he who is a nuisance.' (Syncope is possible after /cess-/ as well as after /c<sup>w</sup>ss-/: cés-tákws-si-c-ikk (bother-sound-AI-3AN-33PROX) 'they (du., abs.) who were talking constantly.')

The seemingly anomalous syncope in cás-tákws-so can be accommodated without complicating our analysis of V-slot

epenthesis if we suppose that a certain amount of idiosyncratic information about syllabification may be represented in lexical entries. In particular, let us suppose that the second C-slot associated with the segment /s/ in /cəss-/ is syllabified with the preceding vowel in the underlying form of this morpheme. The syllabified underlying form of cəstákwsə will then be as shown in (78), the rest of the syllable structure shown here being that provided by the basic syllabification rules.

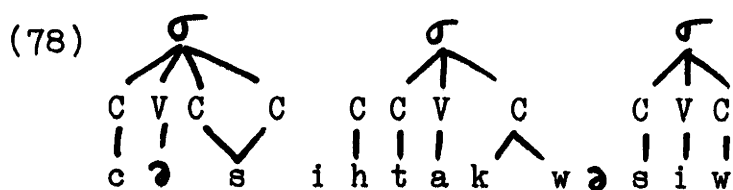

We might, in fact, suppose that underlying forms of words are ordinarily listed in the lexicon with the syllabification required by the basic syllabification rules. These rules could then be taken to function as redundancy rules over lexical entries, as well as applying in the course of derivations. The second association line for the /ss/ of /cəss-/ in (78) would entail an extra cost for the lexical entry for cəstákwsə, since it is not given by the basic syllabification rules.

If (78) is the underlying representation of cəstákwsə, the the second C-slot of the geminate cluster in /cəss-/ is not a possible trigger generalized V-Epenthesis, since it is never unsyllabified. Syncope after /cəss-/ thus falls into line with other cases of syncope.

Of course, if idiosyncratic underlying syllabification in /cəss-/ is the explanation for syncope in cəstákwsə, then we might expect to find evidence of exceptional underlying

syllabification in other derivatives of this root. There does, indeed, appear to be such evidence. For example, the /ə/ of /-əwe-/ 'animal' remains unstressable and may be phonetically deleted after the /ss/ of /cəss-/ in cəss-əwe-wí-hke (bother-animal-DA-much-(3)) 'there are a lot of mosquitoes' (cf. cəss-ò 'mosquito,' h-cəss-əwé-m-əl 'his mosquito'). A comparable idiosyncrasy in the underlying representation of /kəss-/ 'wash' may be responsible for the possibility of syncope in kəs-tək-əní-ke 'he washes clothes,' if this is derived from /kəss-atək-əní-ke-w/ (wash-line-by.hand-AI-3); cf. kəssí-cəwe-ní-ke (wash-dish-by.hand-AI-(3)) 'he washes dishes.'

#### 6.4.5 Initial Syllable Epenthesis

It is a striking fact about syncoating /i/, /a/, and /o/ that they play the same role as underlying unstressable /ə/ in determining stressability when they appear as V in word-initial /(C)ə [+sonorant]ə V/. Nothing needs to be changed in the statement of Initial Syllable Epenthesis to account for this fact, once we decide to represent syncoating /i/, /a/, and /o/ as underlying floating vowels, since the non-syllabic sonorant in word-initial sequences of this type will always be unsyllabifiable when it is flanked by floating vowels, regardless of their quality. It would, of course, be possible to generalize Initial Syllable Epenthesis so that it could provide a slot for a vowel of any quality. Since syncoating /i/, /a/, and /o/ do not



syncopating and non-syncopating /a/. (For the analysis of this stem, see note 4.) If the syncopating vowel is an underlying floating vowel and its non-alternating counterpart has an underlying V-slot, then 'he sins thus' will have the alternative underlying forms shown in (80).

(80) a.

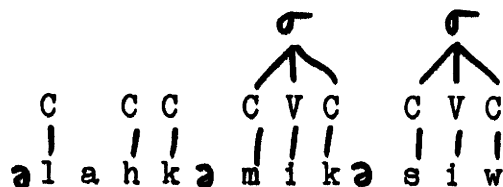

b.

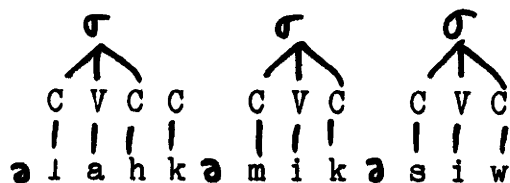

The unsyllabified /l/ in (80a) will trigger Initial Syllable Epenthesis, so the /ə/ of /əl-/ becomes stressable in this case and the /a/ of /-ahkəmik-/ remains unstressable. After syncope, we obtain əl-kə́mík-so. Initial Syllable is not applicable in (80b), however, since the /l/ of /əl-/ can be syllabified here with the /a/ of /-ahkəmik-/. Word-initial unstressed /ə/ is eliminated by Schwa Deletion<sup>v</sup> and the word surfaces as l-áhka~~m~~ík-so. Thus variation in the applicability of Initial Syllable Epenthesis in cases of this kind need not be interpreted as variation in the form or obligatoriness of the rule. The observed variation simply reflects the fact that the reanalysis of underlying unstressable /i/, /a/, and /o/ as inherently stressable vowels is incomplete and has led speakers to set up alternative underlying forms for many morphemes.

#### 6.4.6 Final Syllable Epenthesis

The statement of Final Syllable Epenthesis given in 4.5 must be amended in two ways to account for the alternation between a and zero seen in forms like él-ənók-ah-k (thus-event-II-3IN) 'that which happens' and él-ənok-k-əpən (thus-event-(II)-3IN-PRET) 'that which happened.' The rule must be generalized so that it applies to floating /a/ as well as to floating /ə/. It must also be formulated to permit a final cluster as well as a single word-final C. A revised statement of the rule is given in (81).

#### (81) Final Syllable Epenthesis

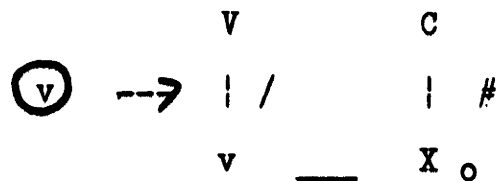

Given (82a) as the underlying representation of él-ənók-ah-k, Final Syllable Epenthesis as revised will derive (82b). Since /a/ is no longer a floating vowel in this structure, it is not subject to syncope here.

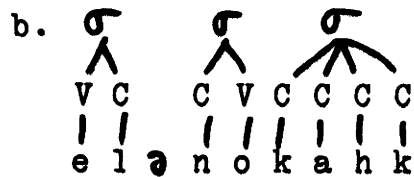
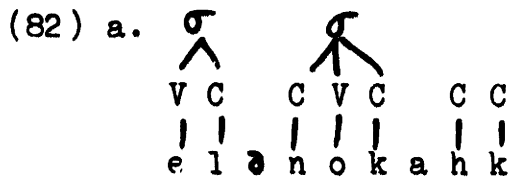

In forms like él-ənok-k-əpən which contain further suffixes, Final Syllable Epenthesis is not applicable, so /a/ remains a floating vowel and undergoes syncope. The element /-ah-/ has an alternative underlying form, however, in which /a/ is associated with a V-slot. The /a/ of this variant does not undergo Syncope II even in suffixed forms, so that we also find unsyncoated examples like él-ənok-á-k-səpən (thus-event-II-3IN-PRET-DUBIT-(SUBJ)) 'if is had happened.'

#### 6.4.7 S-HS Epenthesis

Unlike the other rules of V-slot epenthesis, which either must or may be formulated to apply to any floating vowel, S-HS Epenthesis must not be generalized to apply to floating vowels other than /ə/. While /ə/ is always stressable between /s/ and /hs/, /a/ may remain unstressable in this environment and undergo Syncope II. (There are no relevant examples involving floating /i/ or /o/.). Thus we have h-kís-səm-a-l (3-past-feed-DIR-3.OBV) 'he fed the other,' from /w-kis-ahsəm-a-əl/, and h-kís-sihpíl-a-l

(3-past-give.medicine-DIR-3.OBV) 'he gave the other medicine,'  
from /w-kis-ahsihpil-a- 1/.

As usual, there are variants with stressable /a/ in place of  
syncopating /a/: h-kís-ahsəm-a-1 'he fed the other.' There is no  
reason to suppose that S-HS Epenthesis has applied in the  
derivation of such a form, however. Certainly /ahsəm-/ 'feed' is  
well attested in other environments with inherently stressable  
/ə/.

### 6.5 An abstract alternative

We noted at the beginning of this chapter that syncopating a  
is found only before hC and sC, where C is an obstruent, and  
syncopating i and o only before hC. The account of these  
segments which I have developed in the preceding section provides  
no explanation for this restricted distribution. The abstract  
analysis which Sherwood (1983b:32-33, 39-42) is of interest in  
this connection, since it suggests a principled basis some of the  
observed restrictions, but there are both methodological and  
empirical problems for his analysis which suggest that it cannot  
be maintained. It appears that the distribution of syncopating  
i, a, and o in Passamaquoddy may in fact be arbitrary from a  
synchronic point of view.

In Sherwood's proposal, cases of syncope involving i and a  
are integrated into the larger system of syncope by setting up  
underlying /ə/ for syncopating i and underlying /ǎ/ for  
syncopating a. As I noted in 5.2.13, Sherwood also sets up /ǎ/  
for occurrences of surface ə which do not alternate with zero  
before obstruents. In the analysis which I have offered, these



non-syncoating schwas are derived from /ə/ but are either marked as exceptions to Schwa Deletion I (Syncope I) or treated as inherently stressable, according to their behavior in stress assignment.

In Sherwood's analysis, "weak" /ə/ and /ǎ/ are both subject to syncope before /hC/. Where syncope does not take place, /ə/ becomes i before /hC/, while /ǎ/ is "lengthened" to a in this environment. Any /ǎ/ which remains after syncope in other environments is changed to ə by a rule of absolute neutralization.

Now surface ə which alternates with zero may precedes /sC/: məsk-əm-ən ((3)-find-TI-3IN) 'he finds it,' but psk-əm-ən (find-TI-1-(SUBJ)) 'if I find it.' Sherwood sets up underlying /ə/ in these cases: /məsk-/ 'find.' Presumably, then, we should set up underlying /a/ for syncoating a before /sC/ in the system which he has proposed, although he does not discuss these cases. The lengthening of /ǎ/ must accordingly be extended to apply before /sC/ as well as before /hC/.<sup>9</sup>

Sherwood's proposals also do not cover syncoating o. As we will see below, it is not clear that his analysis can be extended to handle this type of syncope in any natural manner.

A few words about the history of the Maliseet-Passamaquoddy vowel system may help to explain the rationale for Sherwood's analysis. The Proto-Algonquian vowel system shown in (83) was replaced by the Proto-Eastern Algonquian system shown in (84) through the loss of the length distinction in the high vowels and the change of PA \*e to PEA \*ə (Goddard 1980).<sup>10</sup>

(83) Proto-Algonquian

i	o	i·	o·
e	a	e·	a·

(84) Proto-Eastern Algonquian

ə	ī	ō
a	ē	ā

In the development of Maliseet-Passamaquoddy from PEA, \*ə was lost in weak positions before obstruents, but \*a was regularly retained in this environment, except where the consonant preceding \*a was identical with that which followed it. Where \*ə and \*a were not subject to a variety of special treatments, they eventually merged as ə, giving rise to the contemporary situation in which some unstressable schwas alternate with zero before obstruents while others do not. By setting up an underlying distinction between /ə/ and /ǣ/, Sherwood restores the original conditioning factors for syncope in this environment. (Presumably the inherently stressable schwas of the contemporary language reflect perturbations of the original treatment of the historically short vowels.)

Both PEA \*ə and PEA \*a were lost in weak positions before clusters which give Maliseet-Passamaquoddy hC. For the most part, \*ə which remained before these clusters merged with \*i as i, while \*a which remained in this environment merged with \*a as a. Thus PA \*meckw- 'red' gives Passamaquoddy -mihkw- in n-mihkw-ey (1-red-AI) 'I am red' but mkw- in mkw-éyo (red-AI-(3)) 'he is

red.'<sup>11</sup> PA \*tahk- 'cool' gives -tahk- in k-táhk-éy (2-cold-AI) 'you (sg.) are cold (to the touch)' but tk- in tk-éyo (cold-AI-(3)) 'he is cold (to the touch).' Sherwood's analysis duplicates these historical developments by setting up /ə/ and /ǎ/ before /hC/, letting both vowels undergo syncope in this environment, and postulating rules which merge /ə/ with /i/ and /ǎ/ with /a/ as required.

The alternations which Sherwood does not consider represent additional historical complications. PEA \*ə merged with \*o instead of \*i in strong positions before some \*w-final clusters. Thus PA \*atehkwa 'caribou' gives Passamaquoddy ətóhk 'deer.' The result was an alternation between o and zero in this word, as shown by ht-ətk-óm-əl, originally 'his deer' but now specialized in meaning as 'his buck.' In this case, alternation was eliminated through the creation of a new possessed form ht-ətóhk-əm-əl 'his deer'; but the alternation between -ohke-/-ohkwe- and -kwe- in the medial 'body' presumably reflects the rounding of PEA \*ə. (The apparent o/zero alternation in -ohke-/ 'acquire' must reflect reanalysis rather than phonetic change. Bloomfield reconstructs PA \*-ehke - as a final by which "verbs of gathering and producing are derived from nouns" (1946:108).)

PA \*e has become a rather than ə before sC in a few morphemes (perhaps only where it was word-initial, with later generalization to medial occurrences of initial elements). Thus PA \*esp- 'up above' gives Passamaquoddy -asp- in nt-ásp-əp (1-high-sit) 'I sit up high.' Here a continues to alternate after the fashion of \*ə: sp-əpo (high-sit-(3)) 'he sits up high.' If

we set up underlying /ǎsp-/ for contemporary Passamaquoddy in accordance with the extension of Sherwood's system proposed above, then at least this case of /ǎ/ will reflect a restructuring of underlying forms in the course of the history of the language. For the most part, however, the underlying forms assumed in Sherwood's analysis faithfully reflect the vowels reconstructed for PEA.

One problem with Sherwood's approach from a synchronic point of view is that the roles assigned to /ə/ and /ǎ/ are essentially arbitrary. These two underlying segments could in fact be interchanged everywhere before /hC/ and /sC/ without requiring any significant complication of the analysis. Both are subject to syncope in these environments, so the rules which carry out syncope would not have to be changed. All that we would need to do is to take /ǎ/ instead of /ə/ to i before /hC/ and take /ə/ instead of /ǎ/ to a before /hC/ and /sC/. Underlying /ǎ/ would then give a before /sC/ by the context-free rule which merges /ǎ/ with /ə/. (We could make this alternative analysis look more natural by renaming "ǎ" as "ĩ." We could then speak of rules which "lengthen" /ĩ/ to i or "back" /ĩ/ to a.)

The reason that such a switch would be possible is that the segment which underlies syncopating i surfaces only as i and the segment which underlies syncopating a surfaces only as a. Underlying /ə/ before /hC/ and underlying /ǎ/ before /hC/ and /sC/ have nothing in common with /ə/ and /ǎ/ in other environments except the fact that they participate in stressability alternations and syncope. (While /a/ does not

undergo pre-obstruent syncope in Sherwood's analysis, several of his other syncope rules apply to either /ə/ or /ǎ/.)

It might be argued that the same underlying vowel surfaces as either ə or a in those II finals in which ət or ən is replaced by ah before -k 3IN. Sherwood in fact sets up underlying /ǎt/ and /ǎn/ here, thus attributing the vowel alternations in these morphemes to the phonological effects of the consonant mutations. The fact that ə is an exception to pre-obstruent syncope in -ət- is consistent with his claim that this vowel is derived from underlying /ǎ/ and thus offers support for the hypothesis that /ǎ/ is the phonological source of syncopeing a. But ə is consistently treated as an unstressable vowel in the allomorphs of the finals in question in which we find -ət- and -ən-, while the a of their allomorphs before -k is optionally treated as inherently stressable. Thus the relationship between ə and a in these morphemes is not in fact phonologically regular. In any case, little complexity is added to the grammar if we state allomorphy rules for the appropriate finals in which /ət/ or /ən/ is directly replaced by /ah/, rather than rules in which /ǎt/ or /ǎn/ is replaced by /ǎh/.

Sherwood uses the distinction between /ə/ and /ǎ/ to distinguish among various inflectional suffixes in formulating a number of minor rules. In some cases, the applicability of one or another of these rules might be taken to provide evidence for the underlying identity of particular syncopeing vowels. As one might expect, however, there is a great deal of variation among speakers in the details of the phonology and morphology of the inflectional system. Many of the rules which Sherwood considers

are clearly morphologically governed, and it seems likely that morphological conditions may or must replace reference to the distinction between /ə/ and /ä/ in the rules in question.

Thus it appears that there is little or nothing in the phonology of Passamaquoddy to suggest that syncopating i and a are anything other than /i/ and /a/. As we will see in the following section, syncopating i even patterns with non-alternating i in triggering palatalization of root-final /t/ to c -- unhistorically, since PA \*t was replaced by \*c before \*i, \*i, and \*y, but not before e.

Syncopating o presents an even greater problem for Sherwood's theory. While syncopating o is historically derived from \*ə, the o of -ohkwe- 'body' cannot be synchronically derived from /ə/ by any general rule, since we find syncopating i before hkw in -mihkw- 'red.' Nor can the o of -ohkwe- be derived from /a/, since syncopating a occurs before hkw in -tahkw- 'arrest.' Sherwood's system provides two sources for syncopating vowels before hC, but three distinct syncopating vowels occur before hkw.

Moreover, surface ə also appears before hkw, although only in the negative allomorphs of a few Conjunct verb suffixes: skät l-äp-ə-m-ə-ke-w-ə hkw (not thus-look-TA-PASS-NEG-12NEG-(SUBJ)) 'if we (inc.) are not looked at,' skät l-äp-ə-m-in-ə-mə hkw (not thus-look-TA-3(3)/1plNEG-(SUBJ)) 'if he/they does/do not look at us (inc. or exc.).' If we adopt Sherwood's analysis for Passamaquoddy, these suffixes must be marked as exceptions either to the rule which fronts /ə/ to i or to the rule which lengthens

/ǎ/ to a, depending on our choice of underlying /ǎ/ or /ǎ/ for surface ǎ before hkw.

The suffixes -ǎhkw and -inǎmǎhkw of the negative Conjunct paradigms correspond to -ǎkw and -inǎmǎt in the positive paradigms. Several other suffixes follow similar patterns of allomorphy: -ek 11 ~ -ehk or -ehkw 11NEG, -ekw 22 ~ -ehkw 22 NEG. The source of this pattern may have been third person forms in which -t 3AN alternates with -h-kw NEG-3AN, since -t is replaced by -k after a non-syllabic within the positive paradigm, and both -h- and the rounding of kw in -h-kw presumably reflect the former occurrence of the negative morpheme -w- in some way. The extension of h and the alternations t ~ kw and (for some speakers only) k ~ kw to other endings in these paradigms appears to be the result of recent innovations, however. Passamaquoddy -ǎkw 12 represents pre-Maliseet-Passamaquoddy \*-ǎkw, from PA \*-ǎkw (Bloomfield 1946:101). But pre-Maliseet-Passamaquoddy \*\*-ǎhkw would give -ǎhkw, not -ǎhkw. Thus the extension of h into the ending -w-ǎhkw must be more recent than the change of \*ǎ to Maliseet-Passamaquoddy ǎ.<sup>12</sup>

The alternation -ǎkw ~ -ǎhkw would be easy to accommodate within Sherwood's system. We would simply postulate underlying /-ǎkw/ ~ /-ǎhkw/. (In fact Sherwood does set up /-ǎkw/ for -ǎkw, appropriately, given his assumptions, since the ǎ of -ǎkw is inherently stressable in contemporary Passamaquoddy.) The fact that Passamaquoddy could innovate -ǎhkw as the negative counterpart of -ǎkw suggests that -ǎkw had already been reanalyzed as /-ǎkw/ at the time of the change and that /ǎhC/ was

no longer being phonologically replaced by ihC at this point in the history of the language.

Because syncopating o and surface əhC are rare, we cannot claim to have overwhelming empirical evidence against an analysis like Sherwood's which recapitulates the history of syncopating i and a in the synchronic grammar of Passamaquoddy. The case against such an approach does appear quite strong, however, when these empirical problems are considered in conjunction with the arbitrariness of the abstract solution and its heavy reliance on opaque rules of neutralization.

Note, finally, that morphemes like /nikhapi-/ 'blind,' /-akəsən-/ 'shoe,' and /-atək-/ 'line, string,' in which syncopating /i/ and /a/ appear in atypical environments, cease to be problematic once we abandon the attempt to provide a synchronic account of the distribution of these syncopating vowels. Given the analysis of syncope presented in section 4, we do not need to postulate ad hoc occurrences of /h/ in these morphemes to account for the vowel/zero alternations which they display. Syncopating i and a in these elements share a similar history with other occurrences of syncopating i and a, but we are free to attribute their deletion in the synchronic grammar of Passamaquoddy to pre-obstruent syncope (Syncope I) rather than to syncope before /h/ (Syncope II). (Of course it is also possible that the speakers of Passamaquoddy have simply abandoned a phonological analysis of the alternations in these morphemes.)



## 6.6 Syncope and palatalization

The palatalization (or, more accurately, affrication) of /t/ to /c/ before /i/ has figured at several points in the discussion of the last two chapters, notably in 4.2.2. There appear to be at least three palatalization rules in Passamaquoddy, each of which is subject to morphological restrictions. The most general of these rules changes a root-final /t/ to /c/ before connective /i/. A second rule is triggered by inflectional suffixes which begin with /i/. A third rule changes /t/ to /c/ before a synchronically arbitrary class of finals which begin with vowels other than /i/.

Rather curiously, the rule which accounts for the palatalization of root-final /t/ does not affect final /t/ in complex initials and is not triggered by finals which begin with stable /i/. Root-final /t/ is palatalized, however, before medials and finals which begin with syncoating /i/ -- but only when this vowel does not undergo syncope. When /i/ remains unstressable and undergoes syncope, a preceding /t/ surfaces unchanged. We are thus led to the conclusion that palatalization must follow V-Epenthesis. This is a surprising result: since V-Epenthesis can apparently be stated exclusively in phonological terms, we might have expected it to follow a morphologically governed palatalization rule.

### 6.6.1 Connective /i/

Connective /i/ regularly appears when an underlying sequence of two segments associated with C-slots would otherwise occur at a morpheme boundary within a stem. Comparable sequences of non-syllabics which arise through the addition of inflectional suffixes are broken up in a variety of ways. The most general rules for such combinations insert epenthetic /ə/ or epenthetic /o/. These rules are discussed in the following chapter. A few derivational suffixes, including the reflexive and reciprocal finals /-si-/ and /-ti-/, pattern like inflectional suffixes in requiring epenthetic /ə/ or /o/ rather than connective /i/ after a non-syllabic.

The use of connective /i/ after the roots /pəm-/ 'along' and /ətəl-/ 'ongoing' is illustrated in (85) and (86). The examples in (85) show /pəm-/ before a vowel-initial morpheme, then the final /-kətən-/ 'year' after a vowel-final root, and then the combination of /pəm-/ with /-kətən-/, which is made with connective /i/. The examples in (86) show /ətəl-/ before a vowel, then the final /-ne-/ 'die' after a vowel, and finally the combination of /ətəl-/ with /-ne-/.

- (85) a. pəm-ápt-áhso  
along-track-AI-(3)  
'he tracks (a person, an animal, etc.)'

b. máce-kətə̀-k  
 start-year-3IN-(PERF)  
 'next year'

c. pə̀ni-kətən  
 along-year-(3)  
 'the year goes on'

(86) a. təl-apt-áhso  
 ongoing-track-AI-(3)  
 'he is tracking (a person, an animal, etc.)'

b. məté-ne  
 be.heard-die-(3)  
 'he is heard dying'

c. təlí-ne  
 ongoing-die-(3)  
 'he is dying'

The phonological conditions which govern the use of connective /i/ suggest that this element is inserted by a rule of epenthesis like that stated in (87).

(87) Insertion of Connective /i/

	V	C	C	
ɔ̄ -->		/		
	i	X	___	+ Y

Morphological conditions must be placed on this rule, however, to prevent it from applying before inflectional suffixes or before derivational suffixes like /-si-/ and /-ti-/ which require other epenthetic vowels.

The variables X and Y are required in the statement of (87) to prevent the introduction of connective /i/ before morphemes which begin with a floating vowel: connective /i/ is used only when two non-syllabics are adjacent across a morpheme boundary on the segmental tier as well as on the CV tier. The effects of this restriction are illustrated in (88) and (89). The forms in (88) show that the root /kis-/ 'finished, past' adds connective /i/ before a final which begins with a non-syllabic. Connective /i/ is not added, however, before the finals /-ʔpi-/ 'sit, be located,' /-ihkət-/ 'ebb,' and /-ahte-/ 'be located,' despite the fact that the initial segments of these morphemes are underlying floating vowels. The /ə/ of /-ʔpi-/ is an exception to Syncope I, so that it surfaces as an unstressable vowel in (89a). The /i/ of /-ihkət-/ and the /a/ of /-ahte-/ are deleted by Syncope II in (89b) and (89c), so that a surface cluster in fact results at the boundary between root and final.

- (88) a. k<sup>í</sup>s-ew<sup>é</sup>sto  
           past-speak-(3)  
           'he talked'
- b. m<sup>á</sup>c<sup>é</sup>-ko  
           start-grow-(3)  
           'he grows up'
- c. k<sup>í</sup>s<sup>í</sup>-ko  
           finished-grow-(3)  
           'he is full grown'

- (89) a. k<sup>í</sup>s-əpo  
 finished-sit-(3)  
 'it (an.) is finished'
- b. k<sup>í</sup>s-kət  
 past-ebb-(3)  
 'it is low tide'
- c. k<sup>í</sup>s-te  
 finished-located-(3)  
 'it is finished'

Connective /i/ is used not only after roots, but also after initials which are derived from stems. These may be monomorphemic, as in (90), or complex, as in (91). (The personal prefix forms part of the stem of body-part verbs derived with /-ne-/ 'ache'; see the discussion of these verbs in 5.4.2.)

- (90) a. s<sup>ó</sup>kəl  
 'sugar'
- b. s<sup>ó</sup>kəl<sub>i</sub>-ne  
 sugar-ache-(3)  
 'he has diabetes'
- (91) a. cá<sup>l</sup>ək<sup>ə</sup>ss  
 'ear'
- b. h-cá<sup>l</sup>ək<sup>ə</sup>ss<sub>e</sub>-w<sup>í</sup>-ne  
 3-ear-DA-ache-(3)  
 'he has an earache'

Connective /i/ may also appear between an initial and a medial, between two medials, or between a medial and a final, whenever two segments associated with C-slots would otherwise be adjacent:

(92) a. ápsí-kw-e

small-face-AI-(3)

'he has a small face'

b. kín-aləkí-kw-e

large-hole-face-(3)

'he has big eyes'

c. hkwát-atəkí-ye

one-line-go-(3)

'it is one string (e.g. of beads);

it has one strand'

cf. (93) a. áps-alək-əso

small-hole-AI-(3)

'it (an.) has a small hole in it'

b. áps-átək-əsə-ss-o

small-line-AI-DIM-AI-(3)

'he is thin (said of a snake, a string, etc.);

'he is skinny (said of a person)'

The TA stem /əli-kpe-ihte-h-/ 'pound (as brown ash),' used as an initial in (94a), contains an internal occurrence of connective /i/, as a comparison with (94b) reveals. I assume that the /i/ oh /-hi-/ in these examples is also connective /i/, but I have not recorded the final /-ke-/ in combinations in which it is not preceded by /i/.

- (94) a. lí-kpe'-hti-hí'-ke  
 thus-brown.ash-strike-TA-AI-(3)  
 'he pounds brown ash'
- b. máce-kpe'-hti-hí'-ke  
 start-brown.ash-TA-AI-(3)  
 'he begins pounding brown ash'

Analyzing connective /i/ as an epenthetic vowel not only accounts for the distribution of this element, but also explains why there is no class of initials which end in a non-syllabic but regularly combine directly with a following morpheme which begins with a non-syllabic. Some complex initials are problematic on this account, however. Certain finals end in /i/ when they occur as the last element of a stem, but appear to have basic forms which lack this /i/ when they occur in the corresponding initials, adding /i/ only before a non-syllabic. The final /-kapəwi-/ 'stand,' for example, appears as such in (95a), but shows up as /-kapəw-/ in (95b) and apparently adds connective /i/ in (95c).

- (95) a. h-téhsahkwi-kapəwi-n  
 3-on.top-stand-PEG  
 'he stands on top of it'
- b. h-kísí-kapəw-éhl-a-l  
 3-past-stand-TA-DIR-3.OBV  
 'he stood up, erected the other'
- c. wíwəni-kapəwi-htəw-á-wa-l  
 (3)-around-stand-TA-DIR-33PROX-3.OBV  
 'they stand around the other'

The reflexive suffix /-si-/ takes this form in (95a), lac.'s /i/ in (96b), and appears with connective /i/ in (96c).<sup>13</sup>

(96) a. náci kəs-pa-hl-əsi-n

(1)-go wash-liquid(?) -TA-REFLEX-SUBORD

'I will go and wash myself'

b. nt-ətəl-əkéhkim-s-əh-əkw

1-ongoing-teach-REFLEX-TA-INV

'he (e.g. a dental student) is teaching himself  
by working on me'

c. wícóhke-m-sí-kətən

help-TA-REFLEX-year-(3)

'the time has come when someone who has never  
done things for himself starts to do so'

cf. d. kéhkim-so

teach-REFLEX-(3)

'he teaches himself'

For initials formed with /-kapəw(i)-/ and /-s(i)-/, an analysis in which /i/ is deleted before a vowel might appear to be preferable to one in which /i/ is inserted before a non-syllabic. Examples like (95) and (96) thus lend some plausibility to the idea that connective /i/ is always added to initials which end in a non-syllabic when complex stems are formed. The surface distribution of connective /i/, on this account, would be due to deletion, rather than to epenthesis.

Note, however, that /i/ would have to be deleted before floating vowels as well as before segments associated with V-slots. Our notation for phonological rules makes it easy to



state that a segment is associated with a C-slot, but makes it difficult to state that a segment is not associated with a C-slot (i.e., is associated with a V-slot or is unassociated). Thus a rule which would delete /i/ as required would necessarily be more complex than our insertion rule (87), at least as long as we are framing it within the CV theory of the stressable/unstressable distinction. I will accordingly assume that /i/ is in fact epenthetic in finals like /-kapəw(i)-/ and /-s(i)-/ when they occur in stem-internal positions.

In any case, a more common pattern of derivation from stems which end in /i/ involves the use of the derivational affix /-w-/, which may then be followed by connective /i/. The initials in (97) correspond to the AI stems /kətohpɪ-/ 'be hungry' and /məsəhk-eyi-/ 'be sorry (about something)'. Both show the effects of I-Mutation, which given /ə/ for stem-final /i/ before /-w-/.

- (97) a. n-kətohpə-wi-tahə-s  
 1-hungry-DA-think-AI  
 'I think I like the taste (of something)'
- b. psəhk-eyə-wi-nəkw-ət  
 sorry-AI-DA-look-II-(3)  
 'it looks tragic, regrettable'

### 6.6.2 Palatalization

Root-final /t/ is always replaced by c before connective /i/, resulting in alternations like those shown in (98)-(100).

- (98) a. pét-óte  
 arrive-move-(3)  
 'he moves (his household) in'
- b. h-péci-ph-a-l  
 3-arrive-carry-DIR-3.OBV  
 'he brings the other'
- (99) a. méht-ewésto  
 finish-speak-(3)  
 'he finished speaking'
- b. méhci-ne  
 finish-die-(3)  
 'he dies'
- (100) a. hkwát-áláki-kw-ésso  
 one-hole-face-move-(3)  
 'he winks'
- b. hkwáci-kátán  
 one-year-(3)  
 'it is one year'

It is clear that /t/ rather than /c/ should be regarded as basic in these alternations, since there are no roots in which /t/ is not palatalized before connective /i/, but there are a few roots like /mác-/ 'bad' in which c appears in all environments:

- (101) a. məc-álək-ətón-e  
 bad-hole-mouth-AI-(3)  
 'he has a dirty mouth (uses bad language)'
- b. məcí-ko  
 bad-kind-(3)  
 'he is bad'

Roots like /məc-/ would have to be marked as exceptions to any rule which would derive /t/ from /c/, but present no problem for a rule which derives /c/ from /t/.

Root-final /t/ is palatalized before syncope of /i/ as well as before connective /i/, but only when /i/ is not deleted. The result in stems like those shown in (102)-(104) is paradigmatic alternations between t and c, as /i/ is deleted or retained according to the shifting patterns of stressability.

- (102) a. h-pət-té-ləw-a-l  
 3-accidentally-strike-shoot-DIR-3.OBV  
 'he accidentally shoots the other'
- b. pc-íhte-ləw-à-t  
 accidentally-strike-shoot-DIR-3AN-(SUBJ)  
 'if he accidentally shoots the other'
- c. pét-te-ləw-à-t  
 accidentally-strike-shoot-DIR-3AN-(PERF)  
 'when he accidentally shot the other'
- (103) a. n-ót-ti-hí-k  
 1-from-strike-TA-AI  
 'I win'

b. hc-ihti-hí-ke  
from-strike-TA-AI-(3)

'he wins'

c. wét-ti-hí-ke-t  
from-strike-TA-AI-3AN

'he who wins'

(104) a. hc-íhkaw<sup>ó</sup>tó-w-ək  
from-du.walk-3-33PROX

'they (du.) come from there (on foot)'

b. wét-kaw<sup>ó</sup>tí-hti-t  
from-du.walk-33PROX-3AN

'they (du.) are coming from there (on foot)'

Of course, in most stems there is no paradigmatic variation in the pattern of stressability. Underlying /t/ surfaces unchanged throughout the paradigms of the verbs in (105).

(105) a. pét-kaw<sup>ó</sup>tó-w-ək  
arrive-du.walk-3-33PROX

'they (du.) arrive here by walking'

b. kwét-kaw<sup>ó</sup>tó-w-ək  
try-du.walk-3-33PROX

'they (du.) try to walk'

c. ménakát-kaw<sup>ó</sup>tó-w-ək  
quiet-du.walk-3-33PROX

'they (du.) walk slowly'

Given this much information, a phonological statement of palatalization appears straightforward. Rule (106) will derive

the right forms where root-final /t/ is followed by connective /i/ or syncope /i/, provided that it is ordered after V-Epenthesis.<sup>14</sup> The order of (106) with respect to syncope is unimportant: by requiring /i/ in the environment for the rule to be associated with a V-slot, we assure that (106) will be applicable in (197a) but not in (107b), even though floating /i/ has not yet been deleted in the latter. By requiring a morpheme boundary before the triggering /i/, we also correctly prevent the application of palatalization in morpheme-internal /ti/ (cf. tíhtiyas 'bluejay').<sup>15</sup> (I assume that there are morpheme boundaries on either side of connective /i/, by convention.)

(106) Palatalization (preliminary statement)

C	C	V
	/ \	
t	t š	i

(107) a.

σ	σ	σ	σ
/ \	/ \	/ \	/ \
C	C V C	C V C	C V C
wə	t i h k a wə	t ə wə	k

(gives hc-íhkawəto-wək)

b.

σ	σ	σ	σ
/ \	/ \	/ \	/ \
C	C V C	C C V C	C V C
w e t	i h k a w	t i h t i t	

(gives wét-kawəti-hti-t)

Several considerations suggest that this analysis is too simple, however. First, the /t/ of the personal prefixes is not subject to palatalization before stems beginning with /i/:

- (108) a. nt-íkətáhəm  
 1-yawn  
 'I yawn'
- b. kt-íy-ólti-ne-n  
 2-have-PL-3IN-11  
 'we (pl. inc.) have it'
- c. ht-ípísi-m  
 3-switch-POSS  
 'his switch, whip'

Moreover, /t/ is not palatalized before connective /i/ when it is the last segment of an initial which is derived from a stem, rather than the last segment of a root:

- (109) a. w-ípítí-ne  
 3-tooth-ache-(3)  
 'he has a tooth ache'
- cf. b. w-ípít  
 3-tooth  
 'his tooth'

These restrictions may be accommodated by adding a morphological condition to (106) as follows:

(110) Palatalization I

C	C	V
	→ / \ /	___ +
t	t    ʃ	i

Condition: /t/ belongs to a morpheme of the category root.

Palatalization I will account for the change of /t/ to c in particles and preverbs formed from roots by the addition of /-i/, as well as the cases of palatalization within verb stem already noted. The underlined items in (111) correspond to roots in final /t/ which were illustrated in (103c) and (105c).

- (111) Ksá-ha ménákac-i-w wéc-i skàt  
 in-go quiet-PART-PART from-PART not  
 tóhk-<sup>i</sup>m-á-w-ət wás-is.  
 awake-TA-DIR-NEG-2/3(3) child-DIM.

'Go (sg.) in quietly so that you will not wake the child.'

Palatalization in two other environments is not covered by rule (110), however.

First, an additional rule is needed to account for the fact that /t/ becomes /c/ before the participle endings which begin with /i/, as shown in (112) and (113).

- (112) a. étal-əlóhke-t  
 ongoing-work-3AN  
 'he who is working'  
 b. étal-əlóhke-li-c-ihí  
 ongoing-work-OBV-3AN-33.OBV  
 'they (du., obv.) who are working'

(113) a. némi-y-okt-spən-ik

see-TA-11/3(3)-PRET-33PROX

'they whom we (exc.) see'

b. kisi lí-lámén-h-am-aw-ókc-ik

paɛt thus-paint-TI-TI-TA-11/3(3)-33PROX

'they whose (e.g. houses) we (exc.) painted'

While palatalization in participles has the same historical origin as palatalization in roots, the two processes appear to be formally independent in the synchronic grammar of Passamaquoddy. The rule for participles may be stated as Palatalization II:

(114) Palatalization II

          C          C  
| ---> / \ / \_\_\_ + i  
t          t      š

where /i/ belongs to one of the participle endings  
/-il/ 3.OBV, /-il/ 33IN, /-ik/ 33PROX, /-ihi/ 33.OBV,  
etc.

Palatalization also takes place before a small number of finals which begin with /e/, including /-essi-/ AI and II 'move rapidly' and the abstract finals /-ehl-/ TA, /-ehto-/ TI, and /-eyi-/ AI and II, and the noun final /-eya-/. The examples in (115) show /at-/ 'change,' /wikəwat-/ 'enjoy' and /wət-/ 'from' with basic /t/ unpalatalized. Those in (116) show the same roots with c for /t/ before /e/.



- (115) a. át-óte  
 change-move-(3)  
 'he moves (changes residence)'
- b. wíkwat-ewésto  
 enjoy-speak-(3)  
 'he likes to talk'
- c. ht-ámihk-éssó  
 from-up-move-(3)  
 'he gets up from there'
- (116) a. ác-éssó  
 change-move-(3)  
 'he, it moves to a different location'
- b. ht-ác-éhl-a-l  
 3-change-TA-DIR-3.OBV  
 'he changes, moves the other'
- c. ht-ác-éhto-n  
 3-change-TI-3IN  
 'he changes, moves it'
- d. éci-hc      wíkwac-éyi-k  
 very-FUTURE enjoy-II-3IN  
 'it will be a lot of fun (Conjunct)'
- e. hc-éya-k  
 from-NOUN.FINAL-33PROX  
 'those (an.) from there'

Palatalization before /e/ is clearly not phonologically predictable. Thus /meht-/ 'finish' and /wíkwat-/ 'enjoy' surface with t before /-ewesto-/ 'speak' in (99a) and (115b).

Both /nat-/ 'come, go' and /pet-/ 'arrive' retain /t/ before /e/ in (117a,b).

(117) a. nat-ewət-ów-a-n

(3)-go-arrange-TA-DIR-PEG

'he comes (or goes) and gets it for the other'

b. pét-ék-əpo

arrive-sheet-sit-(3)

'it (an., cloth-like) comes to be located here'

One morpheme beginning with /o/ also triggers palatalization of root-final /t/, the AI final /-ohse-/ 'walk.' Examples are given in (118). The roots shown here appear with final /t/ in (105).<sup>16</sup>

(118) a. péc-óhse

arrive-walk-(3)

'he comes walking'

b. kwéc-óhse

try-walk-(3)

'he tries to walk'

c. ménákac-óhse

quiet-walk-(3)

'he walks slowly'

Since the change of /t/ to /c/ in examples like (116) and (118) is not triggered by /i/, it appears that a third palatalization rule is required for these cases, which might be stated as follows:

(119) Palatalization III

C            C  
| --> / \ / \_\_\_ + V  
t            t    š

where V belongs to a designated class of finals.

A final puzzle is presented by the fact that finals which begin with stable /i/ rather than syncopating /i/ do not trigger palatalization. There are very few basic finals of this type, and most stems which begin with /i/ cannot be used as derived finals. The failure of palatalization in verbs of possession like (120a) is probably to be expected, since the final /-i-/ forms stems from possessed themes, rather than from roots. But surface hkwat- 'one' is unexpected in (120b), since a suffix -insk is easily identified in numbers: compare nís-insk 'twenty.' (I assume the /i/ is not the connective vowel in (120b), since there are otherwise no examples in which <sup>root</sup>/t/ is retained before connective /i/. For palatalization in /nəkwat-/ 'one,' cf. (100b).)

- (120) a. w-ípit-i-w  
          3-tooth-AI-3  
          'he has teeth'  
      b. hkwát-insk  
          one-ten  
          'ten'

An interesting case is furnished by the verb /imiya-/ 'pray.' While the independent stem of this verb begins with /i/, the corresponding final has the form /-miya-/:

- (121) a. ímiye  
pray-(3)  
'he prays'  
b. máce-míye  
start-pray-(3)  
'he starts to pray'

Some speakers now make a distinction, however, between /-miya-/ 'pray' and a new final /-imiya-/ 'attend church.' Connective /i/ is used with /-miya-/, and triggers palatalization as expected. But /-imiya-/ combines directly with roots which end in /t/ and does not trigger palatalization. Thus for some speakers we find the following contrast:

- (122) a. wíci-míye  
with-pray-(3)  
'he prays with others'  
b. wít-imíye  
with-attend.church-(3)  
'he attends church'

Since finals which begin with stable /i/ apparently do not trigger Palatalization I, it is possible that speakers also no longer attribute palatalization before syncoating /i/ to this rule. Morphemes like /-ihte-/ 'strike' and /-ihkawəti-/ 'walk (dual)' may have been reinterpreted as triggers of Palatalization

III instead. Under either account however, the rule which is responsible for the change of /t/ to /c/ before morphemes which begin with syncopating /i/ must be ordered after the rule which determines alternating stressability (V-Epenthesis in the CV framework), since palatalization must be restricted to cases in which syncopating /i/ is retained on the surface.

-- Notes --

1. I have also heard [albohta] as the Passamaquoddy pronunciation of Alberta, used as a woman's name.

2. Both of these elements may be complex: the first perhaps contains the II final /-ət-/, while the second is related in some fashion to TA /-ihpawəl-/.

3. Thus máce-hkawətó-w-ək (with regular loss of unstressable /i/ after a vowel) may mean either 'they (du.) set out on foot, start walking' or 'they (du.) make each other go home by accompanying each other'; cf. máce-hkaw-a-l 'he makes the other go home by following him.'

4. Compare the particle and noun final /-ahkəmikw/ 'land' and the corresponding medial /-ahkəmik-/, which sporadically undergo syncope: skit-kəmikw (surface-land) 'on earth,' kt-ahkəmikw (big-land) 'land' (expected), but h-kiht-ahkəmik-om (3-big-land-POSS) 'his land' (unexpected); pəm-kəmik-e-k (along-land-II-3IN) 'lined up on the ground,' tétp-ahkəmik-e (even-land-II-(3)) 'it is flat land' (expected), but míl-ahkəmik-e (various-land-II-(3)) 'it is hilly land' (unexpected). Etymologically connected with this medial, the element /-ahkəmik-/ in the complex /-ahkəmik-si-/ 'sin' also optionally undergoes syncope: l-ahkəmik-so ~ əl-kəmik-so 'he sins thus.' (This is PA \*eθ-ahkamik-esi-w-a (thus-space-AI-3-3.AN.PROX) 'he carries on so' (Bloomfield 1946:91, 117).)

5. Against such an analysis, however, is the fact that we find skwətwəhkasí- ~ -askwətwəhkasí- ~ eskwətwəhkasí- AI 'be red hot,' a derivative of skwət 'fire' (Leavitt and Francis 1984:90).

6. I have also recorded máskəsəne 'he shoes stink,' an irregular variant of másk-aksən-e (smelly-shoe-AI-(3)).

7. This view is supported by variation in the verbs əl-kwé-hsin ~ l-ohké-hsin 'he lays his head down' and əp-kwé-hsin ~ (p-ohké-hsin) 'he lays his head on something,' in which -kwe- ~ -ohke- 'head' presumably represents the same original morpheme as -kwe- ~ -ohkwe- 'body.'

8. Chamberlain (1899) gives Maliseet "ki'-sok" 'day.'

9. Note that inherently stressable ə may precede /sC/: sep-əske-hté-hsən (separate-bone-strike-lie-(3)) 'it becomes

dislocated (of a bone),' náskamákan 'metal disk worn as an ornament.' But we cannot derive á from /a/ in such forms if /a/ surfaces as a before /sC/. Thus cases of this type provide clear evidence against an analysis like Sherwood's which does not distinguish between inherently stressable á and a which exceptionally fails to undergo Syncope I.

10. I follow Goddard's convention here in using a raised dot to indicate vowel length for PA but a macron for PEA. It has been suggested that PEA made a distinction between lax and tense vowels rather than one between short and long vowels. Certainly the PEA system seems peculiarly skewed if a length distinction was involved.

11. The PA reconstructions cited in this paragraph and the next are all from Bloomfield (1946, nos. 68, 67, 174, and 21).

12. The use of -áhk for -ákw in negative Conjuent forms may in fact reflect a change in progress. Some negative forms have -ákw where one might have expected -áhk: wéci skát tóhki-m-á-w-ákw (from not awake-TA-DIR-NEG-12) 'so that we (inc.) do not awaken him.'

13. Note that -s-áh- in (96b) cannot be analyzed as -sá-h- from /-si-h-/, with the TA final /-h-/ instead of /-áh-/, since (1) /-h-/ is replaced by /-y-/ after /i/ and (2) /i/ is not subject to assimilation to a following vowel across /h/.

14. Although the analysis of c as a sequence on the segmental tier seems well motivated on other grounds, it makes an affrication rule like (106) appear quite awkward and arbitrary. Since this is a problem for the CV framework itself, however, rather than specifically a problem for the analysis of Passamaquoddy, I will have nothing more to say about this matter here.

15. It is not sufficient to restrict palatalization to "derived environments." Palatalization does not take place within a morpheme even before /i/ derived from /e/ by E-Mutation, as in walati-yik 'plates, bowls, etc.' (stem /waláte-/). For a discussion of E-Mutation, see 8.3.

16. The final /-ohse-/ appears as /-wse-/ after roots ending in /a/ or /e/. Nonetheless, there appears to be no motivation for an analysis which would derive the /o/ of /-ohse-/ via mutation of connective /i/ before the /w/ of /-wse-/. Other finals beginning with /w/ do not alternate. For example, connective /i/ surfaces unmodified in péci-wéhse (arrive-gust-(3)) 'a gust of wind comes over the water.' Moreover, /-ohse-/ is historically derived from Proto-Algonquian \*-oh<sup>h</sup>e-: PA pemoh<sup>h</sup>e-wa 'he walks along' (Bloomfield 1946:111) > Passamaquoddy pom<sup>h</sup>se. At least historically, then, /-wse-/ is presumably derived from /-ohse-/.

## Chapter 7

### Epenthesis on the Segmental Tier

Since the CV tier and the segmental tier are formally independent, we might expect to find rules which insert elements on one tier without inserting corresponding elements on the other. These would be rules which create empty slots or introduce floating segments.

Several rules which insert V-slots have been proposed in the preceding chapters. It appears, however, that all of the rules of this type in Passamaquoddy are "phoneme driven," in the sense that they insert V-slots only in positions where there are floating vowels to be linked with them. Thus there is no type of epenthesis in Passamaquoddy which creates empty V-slots.

On the other hand, there does appear to be motivation in Passamaquoddy for a rule which inserts floating vowels. A dozen or more suffixes which begin with a non-syllabic element in their basic forms add an epenthetic /ə/ when they follow a morpheme which ends in a non-syllabic. The insertion rule is morphologically governed, applying primarily to inflectional suffixes, with various exceptions among these. The schwas inserted by this rule behave like the unstressable vowels which are present in underlying forms with respect to stress assignment and syncope. Thus the simplest analysis of epenthesis will posit

a rule which introduces unstressable /ə/. Formulated in the terms of the CV theory of stressability, this rule will insert /ə/ on the segmental tier without inserting an associated V-slot. This rule is introduced in 7.1.

Under restricted circumstances, epenthetic /o/ is used before certain suffixes in place of epenthetic /ə/. Epenthetic /o/ is always stressable: it is always counted in assigning stress and is never subject to syncope. Thus the rule for the use of epenthetic /o/, like the rule for connective /i/, must be formulated so that it inserts a stressable vowel, both a feature matrix and a timing slot. This rule is formulated in 7.2.

Since a full treatment of the phonology of the Passamaquoddy inflectional system is beyond the scope of the present work, the analyses presented in this chapter are necessarily simplified in certain respects. Not all of the suffixes which trigger the insertion of /ə/ or /o/ are discussed below, nor do the rules proposed here account for all occurrences of /ə/ and /o/ in the Passamaquoddy suffix system which might be regarded as epenthetic. A good deal of morphological and phonological variation is ignored in this discussion.

The basic point at issue here would not be affected, however, if the scope of our investigation were expanded. Some occurrences of /ə/ are phonologically inserted as unstressable vowels. If unstressable vowels are floating vowels, then the grammar of Passamaquoddy must include a rule which inserts material on the segmental tier alone. A few sample derivations are given in section 3 to illustrate the ways in which these



epenthetic vowels are treated by subsequent rules of V-slot epenthesis and syncope.

### 7.1 Epenthetic /ə/

Initial motivation for a rule of Schwa Epenthesis is provided by differences in the phonological treatment of the locative suffix /-k/ and the proximate plural suffix /-ək/.<sup>1</sup> These suffixes are shown after consonant-final stems in (1) and after typical stems ending in /i/, /e/, and /a/ in (2). Stem-final vowels are deleted in the unsuffixed forms in (2) by Final Vowel Deletion.

	prox. sg.	locative	prox. pl.
(1)	ákəm 'snowshoe'	ákəm-ək	ákəm-ək
	émkwán 'spoon'	émkwán-ək	émkwán-ək
	kísóhs 'sun, moon'	kísóhs-ək	kísóhs-ək
(2)	ápəs 'tree'	ápəsi-k	ápəsi-yík
	wálət 'dish, plate'	wáləte-k	wáləti-yík
	póhtáy 'bottle'	póhtáya-k	póhtáya-k

The locative suffix and the proximate plural suffix have the same surface shape after a non-syllabic (-ək) and after /a/ (-k), but have different surface forms after /i/ and /e/ (-k and -yík, respectively). These similarities and differences may be accounted for as follows.

In underlying forms, the locative suffix is represented as /-k/ and the proximate plural suffix as /-ək/. An epenthetic /ə/ is added to the locative suffix after a non-syllabic. I will

argue in the pages which follow that the rule which inserts this / / should be formulated as in (3).

(3) Schwa Epenthesis

C +	C	
∅ --- ə	/	(morphologically governed)
X	___	Y

After /i/ or /e/, /y/ is added before the suffix /-ək/ by the rule of Glide Insertion, which will be discussed in detail in the following chapter. At a morpheme boundary, /e/ becomes /i/ by another rule which will be discussed in Chapter 8. Schwa following /y/ generally surfaces as i as well, although this change is optional for some speakers. (Many speakers go on to change /iyi/ to ihi in forms like the plurals in (2). Some discussion of this variation will be found in 3.4) The /ə/ of the proximate plural suffix is deleted after /a/, so that /-ək/ is reduced to -k in forms like póhtáya-k in (2). I will return to this point in Chapter 8 as well.

Since the epenthetic /ə/ of the locative suffix is always the last vowel of a word, it will always be treated as stressable, whether or not it is inserted as a floating vowel. To determine whether epenthetic /ə/ is inserted as a stressable or an unstressable vowel, we need to look at a suffix which triggers epenthesis but is not always final in the word. One such morpheme is the possessive suffix /-m/.

The possessive suffix appears on the surface as -m after vowels and as -əm after non-syllabics:

- (4) a. ht-ápsi-m  
 3-tree-POSS-3.OBV  
 'his tree'
- b. ht-áht-awalate-m-al  
 3-AUG-dish-POSS-3.OBV  
 'his dish, plate, bowl'
- c. h-póhatyá-m-al  
 3-bottle-POSS-3.OBV  
 'his bottle'
- (5) a. ht-ápán-am-ai  
 3-bread-POSS-3.OBV  
 'his bread'
- b. ht-átóhk-am-al  
 3-deer-POSS-3.OBV  
 'his deer'
- c. h-cáls-am- l  
 3-grasshopper-POSS-3.OBV  
 'his grasshopper'

(cf. ápán 'bread,' átóhk 'deer,' cáls 'grasshopper')

Here again we can attribute the vowel of the longer suffix alternate to Schwa Epenthesis. Note, however, that this vowel is counted or skipped over in figuring alternating stress just like an underlying floating /ə/: the ə of -am is unstressable after a single C in ht-ápán-am-al and after hk in ht-átóhk-am-al, but counts as stressable after ls in h-cáls-am- l. This is the pattern we expect, of course, if epenthetic /ə/ is inserted as a

floating vowel, since a floating vowel becomes stressable after a cluster which cannot be fully syllabified with a vowel before it.

Now we will see in Chapter 8 that an unstressable vowel is deleted after a stressable vowel by the rule of Vowel Elision. In principle, then, we could take the underlying forms of the locative and possessive suffixes to be /-ə̃k/ and /-ə̃m/, with unstressable /ə̃/, and let Vowel Elision reduce these suffixes to -k and -m after vowel-final stems. In fact, however, it is difficult to demonstrate that Vowel Elision ever applies anywhere except at certain stem-internal boundaries. Moreover, there are other suffixes for which an analysis involving epenthesis can be motivated and where the possibility of underlying /ə̃/ can be excluded.

The clearest cases of this kind involve the suffix /-t/ ~ /-k/ which indicates a third person animate subject in various Conjunct verb forms. The allomorph /-t/ is used after vowels, while /-k/ is used after non-syllabics.<sup>2</sup> Thus we have /-t/ in (6), where the affix follows a vowel-final stem, but /-k/ in (7) and (8), where the stem ends in /m/. Since /-k/ 3AN, like /-k/ 3IN, triggers the deletion of a preceding nasal consonant, the /m/ which conditions the use of /-k/ does not appear on the surface in (7b) and (8b). The corresponding Independent Indicative forms are therefore included for comparison.

- (6) a. <sup>é</sup>pi-t  
 sit-3AN  
 'he who sits'
- b. <sup>é</sup>təli-míya-t  
 ongoing-pray-3AN  
 'as he is praying'
- (7) a. <sup>á</sup>l-həm  
 around-swim-(3)  
 'he swims around'
- b. <sup>á</sup>l-hə-k  
 around-swim-3AN  
 'he who swims around'
- (8) a. <sup>pí</sup>l-kátəm  
 new-married-(3)  
 'he is newly married'
- b. <sup>pí</sup>l-kətə-k  
 new-married-3AN  
 'he who is newly married'

Stems which end in /l/ also take this suffix in a form with /k/ instead of /t/, but in (9b) and (10b) we find surface -ək instead of -k.

- (9) a. əl-kil  
 thus-size-(3)  
 'he is big by so much'
- b. əl-kíl-ək  
 thus-big-3AN  
 'he is big'

- (10) a. tkíkw-əl  
 heavy-AI-(3)  
 'he is heavy'
- b. téhkíkw-əl-ək  
 heavy-AI-3AN-(PERF)  
 'when he was heavy'

If we assume that -k and -ək in fact reflect the same allomorph of /-t/, then the ə of -ək must be epenthetic. If -k were underlyingly /-ək/ in (7) and (8), then we would not expect nasal deletion to be applicable in these forms.

Although we can see from (9b) that an epenthetic /ə/ is added to /-k/ in əl-kíl-ək 'he is big,' no ə appears on the surface in the corresponding position in (11).

- (11) a. əl-kíl-k-əpən  
 thus-size-3AN-PRET  
 'he was big'

We do not need to complicate our analysis of epenthesis, however, to accommodate this fact. This result is just what we expect in any case, given the hypothesis that epenthetic /ə/ is inserted as a floating vowel.

The syllabified underlying form of (11) is (12a). (I assume that initial ə is also epenthetic in the preterite suffix -pən ~ -əpən.) Schwa Epenthesis converts (12a) to (12b). Final Syllable Epenthesis and the reapplication of the basic syllabification rules then derive (12c). At this point, only a single C-slot remains unsyllabified, the C associated with the /k/ of the third person suffix. Since this /k/ is followed by a floating /ə/, V-Epenthesis is applicable. The output of this rule, following another round of syllabification, is (12d).

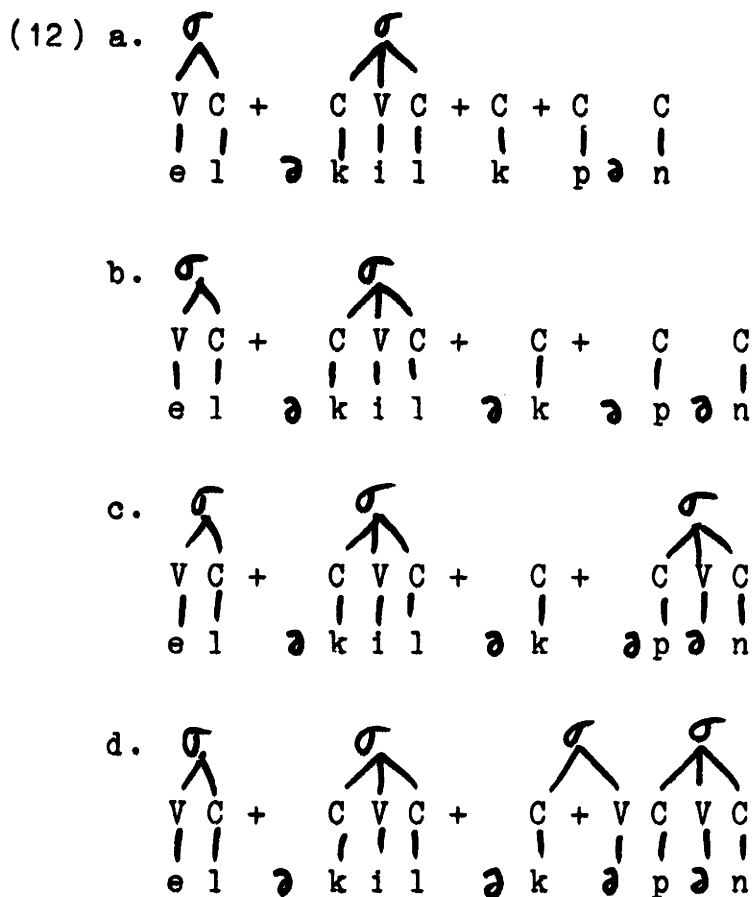

Both the underlying initial /ə/ of /-kil-/ 'be a size' and the epenthetic /ə/ of /-ək/ 3AN remain unassociated with V-slots here. Thus both of these segments are deleted by Syncope I, and we are left with él-kil-k-əpən.

Of course, if / / is inserted as a floating vowel in /-ək/ ʒAN, then we must be able to account its retention in él-kil-ək and téhkikw-əl-ək as well as for its deletion in él-kil-k-əpən. In the first of these examples, epenthetic /ə/ receives a V-slot by Final Syllable Epenthesis; in the second, a V-slot is provided by V-Epenthesis. Syncope is therefore blocked in both cases.

The syllabified underlying form of ékil-ək is (13a). Schwa Epenthesis gives (13b). Here the epenthetic /ə/ of /-ək/ is the last vowel of a word, so it triggers Final Syllable Epenthesis, with results as shown in (13c).

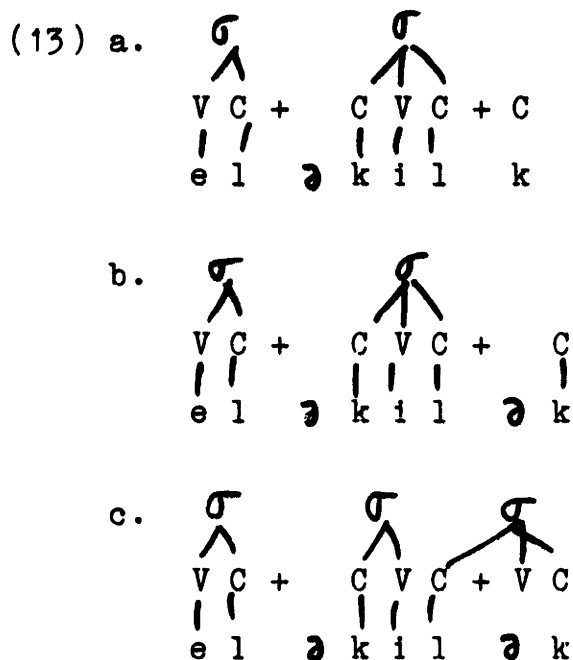

Only the /ə/ of /-əkil-/ remains a floating vowel in this representation, so only this segment is subject to syncope.

As we noted in 5.6.1, the Conjunct perfective suffix apparently consists only of an empty V-slot. Assuming this analysis, the syllabified underlying form of the perfective form téhkikw-əl-ək (heavy-AI-ʒAN-(PERF)) 'when he was heavy' will be (14a). Schwa Epenthesis then derives (14b). Final Syllable



Epenthesis is not applicable in this structure, since the C-slot associated with the /k/ of /-ək/ is not final in the word. V-Epenthesis is applicable, however. Its output is (14c).

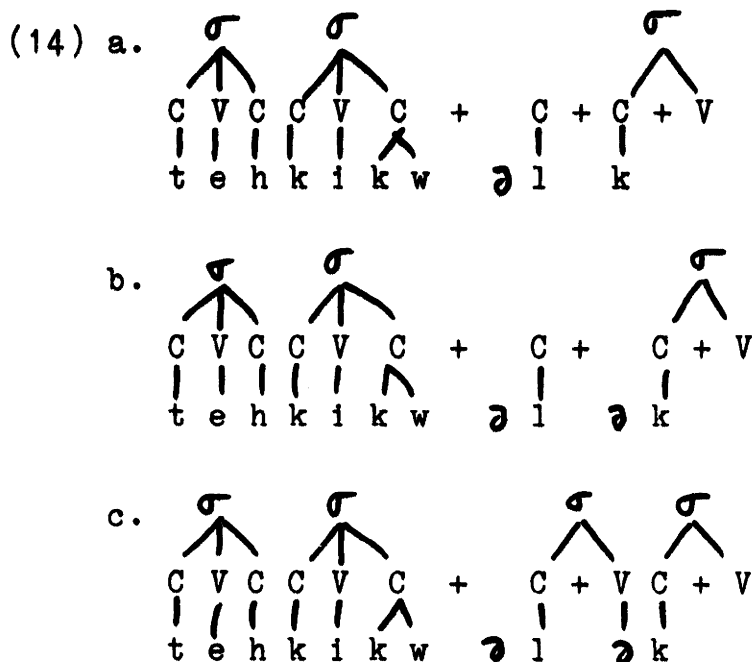

Since the epenthetic /ə/ of /-ək/ is now associated with a V-slot, it is not subject to syncope. The /ə/ of the AI final /-əl-/ remains a floating /ə/ in (14c), but is not deleted because it is followed by a sonorant consonant. The V of the perfective morpheme is ultimately deleted, but is reflected by the rising intonation of the final syllable of téhkikwələk.

We see, then, that the surface distribution of ə in -k ~ -ək 3AN follows from previously motivated rules of V-slot epenthesis and syncope and need not be stated in the rule of Schwa Epenthesis, provided that the latter is formulated as an operation inserting floating /ə/.

## 7.2 Schwa Epenthesis and O-Epenthesis

Initial /ə/ alternates with /o/ in several suffixes which may be added to TA stems, with the choice of the vowel depending on the identity of the final non-syllabic segment of the stem. While alternative analyses are possible, it appears to be best to analyze both /ə/ and /o/ as epenthetic vowels in these cases.

The suffixes which show the pattern of alternation in question include the reflexive and reciprocal finals /-si-/ and /-ti-/, the non-final allomorph /-ko-/ of the inverse theme sign, the so-called passive theme sign /-ke/ (indicating an unspecified subject and a first or second person object), and the theme sign /-l/ (and several historically related morphemes) which is used with a first person subject and a second person object. The reflexive and reciprocal morphemes should presumably be analyzed as derivational suffixes, since they change the stem class of the base to which they are attached, deriving AI stems from TA stems.<sup>3</sup> The other morphemes which take either /ə/ or /o/ as an epenthetic vowel are inflectional suffixes.

Epenthetic /o/ is used after stems ending in /s/, /h/, or /y/.<sup>4</sup> Several examples are given in (15).

- (15) a. ák<sup>h</sup>aw-ahs-óso  
 behind-illuminate(?)-REFLEX-(3)  
 'he shades himself'
- b. ál-to-h-ótə-w-ək  
 thus-strike-TA-RECIP-3-33PROX  
 'they (du.) hurt each other thus  
 (by hitting each other)'
- c. má te n<sup>h</sup>mi-y-óko-wí-nno-k  
 not EMPH (1)-see-TA-INV-NEG-11-33PROX  
 'they do not see us (exc.)'
- d. n-m<sup>h</sup>ós-okè-pən  
 1-cut.hair-PASS-11  
 'we (exc.) get our hair cut'
- e. él<sup>h</sup>mi-ph-óki-yek  
 away-carry-PASS-11  
 'when we were riding (lit., being carried) away'
- f. kt-íy-ol-óhpən  
 2-tell-2.OBJ-PRET  
 'I told you (sg.)'

The same morphemes appear with /ə/ in place of /o/ after most other non-syllabics:

- (16) a. ták-əm-əso  
 hit-TA-REFLEX-(3)  
 'he hits himself'
- b. ksélam-ətə-w-ək  
 like-RECIP-3-33PRX  
 'they (du.) like each other'
- c. n-sík<sup>h</sup>te-hpáwəl-əko-n  
 1-to.death-frighten-INV-3IN  
 'it really scares me'
- d. l-áp-əm-əki-yèk  
 thus-look-PASS-11-(SUBJ)  
 'if we (exc.) are looked at'
- e. k-ták-əm-əl-p n  
 2-hit-TA-2.OBJ-11  
 'we (exc.) hit you (sg. or pl.)'

The word-final allomorph /-kw/ of the inverse theme sign departs from this pattern, however, and takes epenthetic /ə/ after /s h y/ as well as other non-syllabics:

- (17) a. k-pé<sup>h</sup>cí-ph-ək<sup>w</sup>  
 2-arrive-carry-INV  
 'he brings you (sg.)'
- b. n-é<sup>h</sup>mí-y-ək<sup>w</sup>  
 (1)-see-TA-INV  
 'he sees me'
- c. nt-əl-ahk-əl-ək<sup>w</sup>  
 1-thus-throw-TA-INV  
 'he throws me'

The principal reason why it is desirable to treat both /ə/ and /o/ as epenthetic in examples like (15)-(17) is that this move allows us to give a simpler account of a class of cases where it appears that neither epenthetic vowel is used. The argument is based on the treatment of TA stems which end in /əw/.

Stem-final /əw/ is replaced by /a/ before /-si-/, /-ko-/, /-kw/, and /-ke/. (There are special treatments before /-ti-/ and /-l/ which I will not discuss here.) The examples in (18) and (19) show this alternation in the TA stem /not-əw-/ 'hear' and in the TA+O stem /naci-ksəm-əw-/ 'come or go and saw X for y.'<sup>5</sup>

- (18) a. k-nót-əw-a  
 2-hear-TA-DIR  
 'you (sg.) hear him'
- b. k-nót-ə-s  
 2-hear-TA-REFLEX  
 'you (sg.) hear yourself'
- c. k-nót-ə-ko-k  
 2-hear-TA-INV-33PROX  
 'they hear you (sg.)'
- d. k-nót-a-kw  
 2-hear-TA-INV  
 'he hears you (sg.)'

(19) a. náci-ksám-əw-a-n

go-saw-TA-3PASS-PEG

'he goes somewhere to have it sawn for him'

b. náci-ksám-á-ke-n

(1)-go-saw-TA-PASS-PEG

'I go somewhere to have it sawn for me'

Sherwood (1983b:29), apparently following Goddard (1969:17, 19), analyzes /a/ in these forms as the result of a contraction of stem-final /əw/ with epenthetic /ə/, which he assumes is inserted here as after other non-syllabics.<sup>6</sup> While there may be historical justification for this analysis, we can probably achieve a simpler synchronic treatment for Passamaquoddy if we suppose that stem-final /əw/ is directly replaced by /a/ before a non-syllabic.<sup>7</sup> There are, after all, no alternations between surface əwə and a.

Possible confirmation for this analysis comes from the fact that a few schwa-initial suffixes like the first person non-singular inclusive ending -əkw of the Conjunct paradigms neither undergo "contraction" nor have ə for ə after /s h y/: nót-əw-əkw (hear-TA-12-(SUBJ)) 'if we (inc.) hear him/them,' tém-əs-əkw (in.two-cut-12-(SUBJ)) 'if we (inc.) cut him/them in two.'

In Passamaquoddy, the ə of -əkw 12 is inherently stressable, so this vowel would be phonologically distinct from the ə of -əkw INVERSE even if we set up underlying /-əkw/, with unstressable /ə/, for the latter. In the dialect of Maliseet described by Sherwood, however, the ə of -əkw 12 participates regularly in alternating stressability (although it is an exception to

syncope). He prevents this affix from undergoing contraction (and syncope) by giving it the underlying form /-ǎkw/ and formulating contraction (like pre-obstruent syncope) so that it is applicable to /ǎ/ but not to /ǎ̃/.

But none of this is necessary if "contraction" is really a change of /ǎw/ to /a/ before a non-syllabic. Under this analysis, it is sufficient to set up underlying /-kw/ for the word-final allomorph of the inverse morpheme and underlying /-ǎkw/ for the agreement marker. The agreement suffix triggers neither "contraction" nor O-Epenthesis because it begins with a vowel. Each morpheme has an underlying form which is segmentally identical with one of its surface alternates.<sup>8</sup>

If this view of the treatment of stem-final /ǎw/ is correct, then the alternations in (18) and (19) result from the application of a rule which is triggered by consonant-initial morphemes. We are therefore led to the conclusion that both /ǎ/ and /o/ are epenthetic in the vowel-initial alternants of the reflexive suffix, the inverse theme sign, and the passive theme sign, and thus presumably in the other suffixes in which /ǎ/ and /o/ alternate on the same pattern. The observed distribution of epenthetic /ǎ/ and /o/ will follow if we postulate the following rule of O-Epenthesis and order it before Schwa Epenthesis, rule (3) above.

(20) O-Epenthesis

$$\begin{array}{ccc} & V & C + \text{---} C \\ \phi \text{ ---} \rightarrow & | & / | \\ & o & \left\{ \begin{array}{c} s \\ h \\ y \end{array} \right\} \end{array} \quad \text{(morphologically governed)}$$

Where this rule is applicable, epenthetic /o/ will be used. The more general rule of Schwa Epenthesis will insert /ə/<sup>in</sup> cases where an epenthetic vowel is required but O-Epenthesis is not applicable.

As expected, epenthetic /ə/ is subject to syncope, under appropriate conditions, in those morphemes in which ə alternates with o, so that the underlined suffixes in (21) surface without an initial vowel.



- (21) a. wícohké-m-si-kw  
 help-TA-REFLEX-22  
 'help (du.) yourselves!'
- b. wícohké-m-ti-kw  
 help-TA-RECIP-22  
 'help (du.) each other!'
- c. wícohké-m-ko-n  
 (3)-help-INV-3IN  
 'it helps him'
- d. n-míl-ke-né-nno-l  
 1-give-PASS-PEG-11-33IN  
 'they (unspecified) gave them (in.) to us (exc.)'
- e. k-kál-l-əpən  
 2-hide-2.OBJ-11  
 'we (exc.) hide you (sg. or pl.)'<sup>9</sup>

Epenthetic /o/, however, never undergoes syncope: we have má te n-mós-óko-wí-nno-k (not EMPH 1-cut.hair-INV-NEG-11-33PROX) 'they do not cut our (exc.) hair,' but not \*ma te n-mos-ko-wi-nno-k, with -ko- for -oko-. This difference between the two epenthetic vowels is expressed in the formulations of Schwa Epenthesis and O-Epenthesis given here by stating the former as the insertion of floating /ə/ and the latter as the insertion of both the segment /o/ and an associated V-slot.

Both rules are morphologically governed. O-Epenthesis is triggered by /-si-/ REFLEX and /-ti-/ RECIP, but not by other derivational suffixes or by the allomorph /-kw/ of the inverse theme sign. Schwa Epenthesis is also triggered by /-si-/ and

/-ti-/, and by the diminutive suffix /-hs-/ (see the discussion of this morpheme in 4.2.1), but does not otherwise apply within stems. While Schwa Epenthesis is triggered by a variety of inflectional suffixes, including the allomorph /-k/ of the suffix /-t/ 3AN, it is not used with /-k/ 3IN in those forms where /ət/ or /ən/ is replaced by /ah/ before this morpheme (see 6.2). We have also seen in 5.4 that Schwa Epenthesis is not applicable at the boundary between a personal prefix and a stem.

### 7.3 Conclusion

Two rules inserting epenthetic vowels have been proposed in this chapter:

#### (22) O-Epenthesis

$$\begin{array}{ccc}
 & V & C + \text{---} C \\
 \emptyset \text{ -->} & | & / | \\
 & \circ & \left\{ \begin{array}{l} s \\ h \\ y \end{array} \right\}
 \end{array}
 \quad \text{(morphologically governed)}$$

#### (23) Schwa Epenthesis

$$\begin{array}{ccc}
 & C + & C \\
 \emptyset \text{ -->} & ə & / | \quad | \\
 & X & \text{---} Y
 \end{array}
 \quad \text{(morphologically governed)}$$

O-Epenthesis must precede Schwa Epenthesis, since /o/ rather than /ə/ must be inserted into a structure like (24a), the

syllabified underlying representation of n-mós-okè-pən (1-cut.hair-PASS-11) 'we (exc.) get our hair cut.'

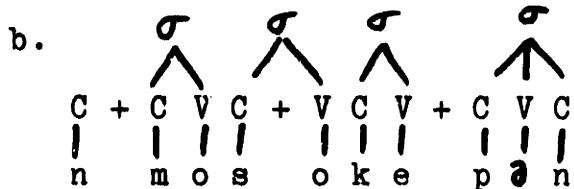
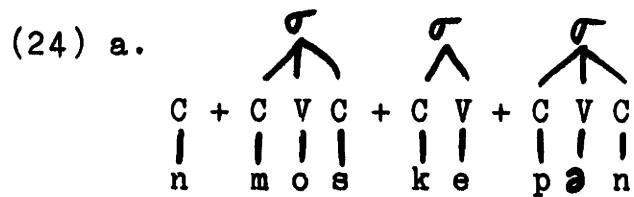

Since O-Epenthesis inserts both a segment and a slot, as shown in (24b), the segments which are introduced by this rule are never subject to syncope.

Where the conditions for O-Epenthesis are not present, Schwa Epenthesis may be applicable instead. For example, the inverse theme sign /-ko-/ triggers the insertion of /ə/ in (25a), the syllabified underlying form of n-síkté-hpawəl-əko-n (1-to.frighten-INV-3IN) 'it really scares me.' The resulting structure is shown in (25b).



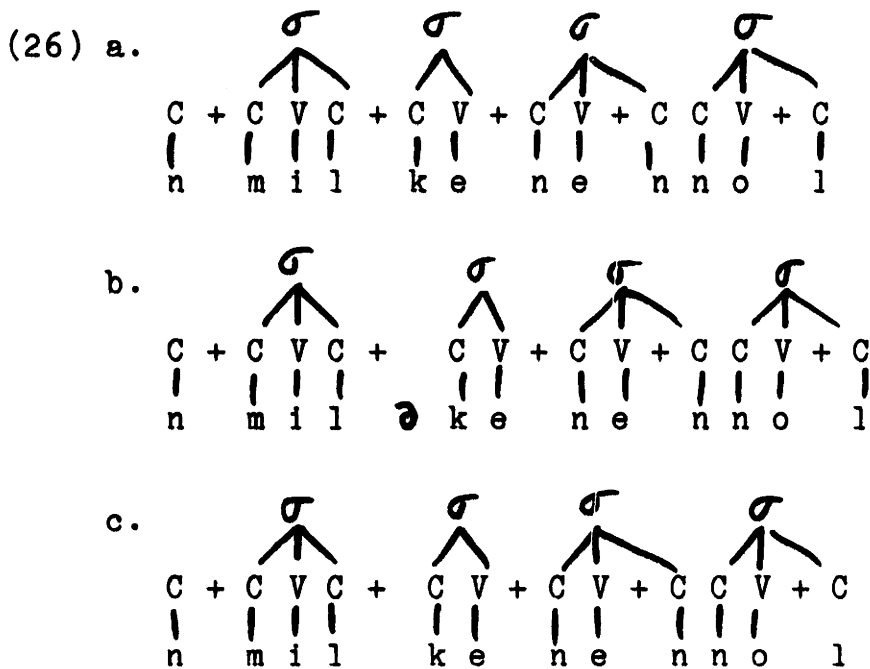

It is not necessary to complicate the statement of Schwa Epenthesis to account for the fact that ə alternates with zero in morphemes which trigger epenthesis, since the rules of syncope will automatically account for the observed alternations, given the hypothesis that epenthetic /ə/ is inserted as a floating vowel.

Schwa Epenthesis is clearly a more natural rule than O-Epenthesis, since the disjunction of /s/, /h/, and /y/ in the latter seems entirely arbitrary from a synchronic point of view. It may be of some interest, then, that some speakers appear to have extended Schwa Epenthesis so that it is optionally triggered by the third person suffix /-w/ of the Independent Indicative paradigms, where epenthesis is not historically expected. In (27) and (28) I give first the forms without epenthesis, which are preferred by all speakers, then the innovatory forms with epenthetic /ə/ (all examples from A.H.). Underlying /wə/ is contracted to o in the first example in each pair.

(27) a. p<sup>é</sup>t-kí<sup>l</sup>-ok (/pet-əkil-w-ək/)  
 arrive-size-(3)-33PROX  
 'they (du.) reach a size (in growth)'

= b. p<sup>é</sup>t-kí<sup>l</sup>-əw-ək

(28) a. ík<sup>ə</sup>t<sup>é</sup>h<sup>m</sup>-ok (/ikətəhəm-w-ək/)

yawn-(3)-33PROX

'they (du.) yawn'

= b. ík<sup>ə</sup>t<sup>é</sup>h<sup>m</sup>-ów-ək

Note that the /ə/ before /w/ remains unstressable in (27b), where the last preceding vowel is stressable. In (28b), where the last preceding (underlying) vowel is unstressable, the corresponding segment is treated as stressable, becoming ó before w. This difference between the two forms is expected if their derivations involve Schwa Epenthesis, since this rule introduces unstressable /ə/.

Schwa Epenthesis will derive (29b) from (29a) in the derivation of p<sup>é</sup>t-kí<sup>l</sup>-əw-ək. Here no rule of V-slot epenthesis is applicable, so epenthetic /ə/ remains a floating vowel when stress is assigned. Syncope I and Schwa Support give (29c).

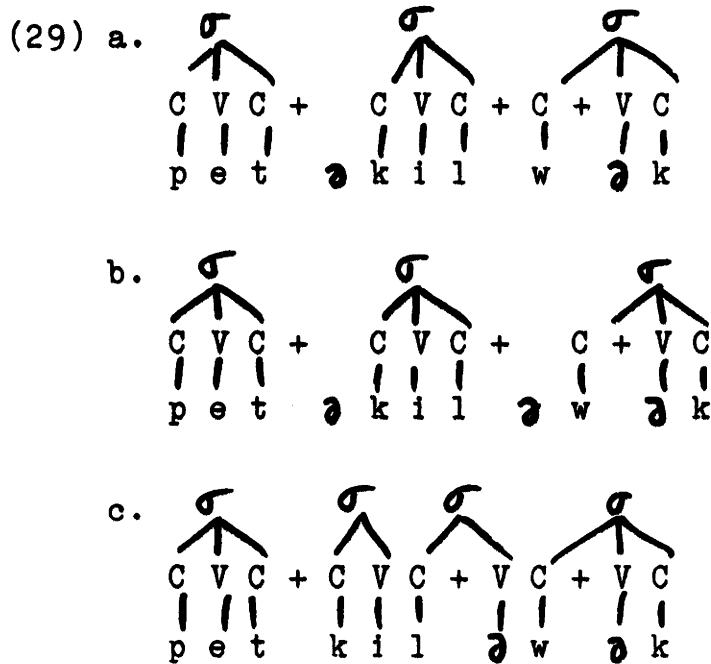

When /ə/ is inserted in (30a), giving (30b), one C-slot remains unsyllabified and triggers V-Epenthesis. The result is (30c), where the epenthetic vowel has been associated with a V-slot. Syncope II and the Schwa Rounding ultimately derive (30d). (See 3.3.3 for the representation of ow as multiply linked o in cases of this kind.)

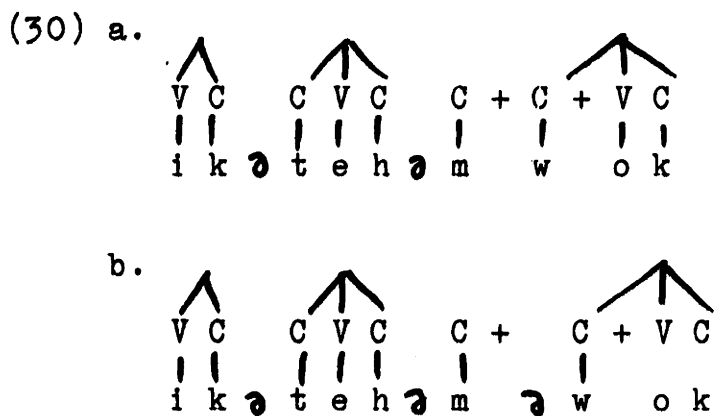

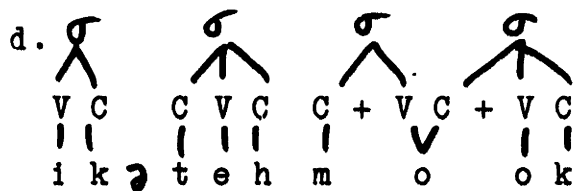
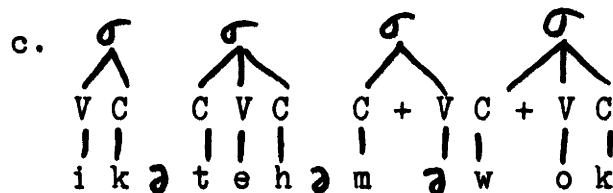

Both the innovatory treatments of the suffix /-w/ that we see in (27) and (28) and the surface distribution of ə where epenthesis is usual for all speakers are readily explained within the CV theory of stressability if we assume that epenthetic /ə/ is inserted as a floating vowel.

-- Notes --

1. The locative suffix is used only in noun inflection. The proximate plural suffix is used in noun inflection and in the inflection of verbs in the Independent Indicative mode. The suffixes /-əl/ 3.OBV, /-ə/ 33.OBV, and /-əl/33IN, which occur in the same morphological position as /-ək/ 33PROX, generally share the phonological treatment of the latter, although obviative plurals present some special problems.

2. This suffix combines with the the TI element /-əw-/ as -akw and with the negative suffix /-w-/ as -hkw: nit wéci nómí-ht-əw-an-s (that from see-TI-TI-1-DUBIT) 'that must be why I saw it,' nit eli nómí-ht-a-kw-s (that thus see-TI-TI-3AN-DUBIT) 'that is what he (reportedly) had seen'; ská étal-əlohk-é-w-ən (not ongoing-work-AI-NEG-2) 'you (sg.) who are not working,' ská étal-əlohk-e-h-kw (not ongoing-work-AI-NEG-3AN) 'he who is not working' (cf. example (112a) of Chapter 6).

3. Both the reflexive and the reciprocal affix may be followed by plural finals, derivational suffixes which are used only with AI and TI stems: kéhkí-m-s-oltó-w-ək (teach-TA-REFLEX-PL-3-33PROX) 'they (pl.) teach themselves,' kéhkí-m-t-oltó-w-ək (teach-TA-RECIP-PL-3-33PROX) 'they (pl.) teach each other.' See 6.6. for examples of other types of derivation from reflexive stems.

4. This seemingly peculiar distribution reflects the historical derivation of stem-final s from \*sw and \*sw and of stem-final h and y from \*hw, with ə representing the contraction



of \*w with epenthetic \* (cf. Goddard (1982:22-24)). Original \*w has since been lost, however, after \*s, \*s, and \*h. For example, the stem mos- of w-mos-a-l (3-cut.hair-DIR-3.OBV) 'he cuts the other's hair' (post-vocalic form) represents PA \*mc•nsw- (Goddard 1982:27). Since there are no stems ending in /s/, /h/, or /y/ which do not take suffix alternates with epenthetic /o/, there would appear to be no justification for a synchronic analysis like that of Sherwood (1983b:31) which sets up underlying stem-final /sw/ and /hw/ for the contemporary language.

5. While it is often possible to justify segmenting TA stems which end in /aw/ so that this sequence can be analyzed as a separate morpheme, it is not clear that this segmentation can be carried out in all cases in which /w/ alternates with /a/.

6. The analysis in terms of contraction is due originally to Bloomfield (1946:92), although he takes the suffix vowels which undergo contraction (PA \*e) to be underlying rather than epenthetic.

7. Compare the similar treatment of final /ow/ in TI stems before the alternate /-kw/ of the suffix /-t/ 3AN (note 2).

8. Alternations in two other Conjunct suffixes must be analyzed as non-phonological allomorphy under the analysis proposed here: (1) The suffix -ask, indicating a third person subject and a second person singular object, alternates with -osk in the usual environments and combines with stem-final /aw/ as -ask. But in Passamaquoddy (although not in Sherwood's Maliseet), the -sk is inherently stressable, at least if we may judge by the failure of syncope in wichoke-m-ask-ik (help-TA-3(3)/2-33PROX) 'they who help you (sg.)'. Thus for Passamaquoddy we must suppose that this suffix has two underlying forms, related by a rule of allomorphy: /-sk/ after /s/, /h/, /y/, and /aw/ and /ask/ (with inherently stressable /a/) elsewhere. (2) The suffix -iht, indicating an obviative subject and a proximate singular object, appears to undergo both syncope and contraction, pointing to underlying or intermediate /-ht/ in Sherwood's analysis: wicohke-m-iht (help-TA-3(3)OBV/3PROX) 'he whom the other helps,' wicohke-m-c-il (help-TA-3(3)OBV/3PROX-3.OBV) 'the other who helps him,' not-a-ht (hear-TA-3(3)OBV/3PROX) 'he whom the other hears.' But in fact "contraction" is optional here (at least for some speakers), and we do not find \*-oht for -iht after /s h y/: not-aw-iht (hear-TA-3(3)OBV/3PROX) 'he whom the other hears,' tem-as-iht (in.two-cut-3(3)OBV/3PROX) 'he whom the other cut in two.' Thus it seems reasonable to postulate allomorphy here as well, although on a different pattern: /-ht/ ~ /-iht/ after /w/, /-iht/ (with syncope /i/) elsewhere. (Data from Leavitt and Francis (1983) and Leavitt (1986).)

9. After stems ending in a stressable vowel followed by /l/, -lapan is apparently in free variation with -alpan: k-kal-al-pan (2-hide-2.OBJ-11) 'we (exc.) hide you (sg. or pl.)'. A similar pattern holds for -lapa ~ -alpa (first person singular on second plural) and for the corresponding negative endings (Leavitt and Francis (1983:39, 41)). There is also an alternate form -alapan, with irregularly unsyncopeated second a, which may be used after stems whose last vowel is unstressable: k-kaselam-al-pan ~ k-kaselam-al-apan (2-like-2.OBJ-11) 'we (exc.) like you (sg. or

pl.).' Since epenthetic /ə/ otherwise undergoes syncope regularly, it may be best to see this variation as a reflection of reanalysis of the theme sign /-l/ and the person/number markers /-pən/ 11 and /-pa/ 22 as underlyingly vowel-initial, or as the result of reanalysis of various surface combinations of the theme sign and a following person/number marker as unit morphemes, followed by analogical shifts in their distributions.

## Chapter 8

### The Treatment of Underlying Vowel Sequences

Vowel sequences do not occur in surface forms in Passamaquoddy, but underlying sequences of two vowels arise at morpheme boundaries. The phonological treatment of these sequences offers significant evidence which bears on the choice between the CV theory of the stressable/unstressable distinction and the diacritic and metrical theories.

Vowel sequences which arise in the derivation of stems are eliminated in one of two ways. If both vowels are stressable, the glide /y/ is inserted between them. If the second vowel is unstressable, it is deleted. These are the only possibilities: the first vowel in any such sequence is always stressable, since no morpheme ends in an unstressable vowel in its basic form. I will refer to the rules which carry out these two types of adjustment as Glide Insertion and Vowel Elision, respectively.

Glide Insertion is applicable in various inflectional environments as well as in stem-internal contexts, but there are no clear cases of the application of Vowel Elision except at stem-internal boundaries. In some cases, the loss of an unstressable vowel could be attributed either to Vowel Elision or to one of the rules of syncope, but deletion can also be demonstrated where none of the syncope rules is applicable.

A rule which I call E-Mutation converts /e/ into an unstressable vowel before inserted /y/. While alternative analyses are possible, I will argue that the output of E-Mutation is floating /i/. What is clear is that the segments derived by this rule receive the same treatment in stress assignment as underlying floating vowels and are subject to a deletion process which resembles syncope, but appear as i where they are retained on the surface. There is some evidence for an extension of E-Mutation to cases in which underlying stressable /i/ becomes an unstressable vowel before /y/.

No matter how we choose to state them, the rules which determine the distribution of stressable and unstressable vowels must follow E-Mutation, since they apply to the output of E-Mutation. E-Mutation must in turn follow Glide Insertion, since inserted /y/ triggers mutation. Although the reasoning is a good deal more complicated, it can also be shown that Vowel Elision must follow all of the principal rules which assign stressability to underlying unstressable vowels if we adopt either a diacritic or a metrical theory of the stressable/unstressable distinction.

From these ordering relationships it follows that the input to Glide Insertion, in the diacritic and metrical theories, must contain both sequences of two stressable vowels and sequences of a stressable and an unstressable vowel. In these frameworks, then, Glide Insertion will have to make explicit reference to the stressable/unstressable distinction. Yet another rule must therefore refer either to the values of a diacritic feature or to accents. As we will see, however, no explicit reference to

stressability is required if we formulate Glide Insertion within the framework of the CV theory.

It follows from the same ordering relationships that underlying sequences of a stressable and an unstressable vowel will not yet have been eliminated, under the diacritic or the metrical theory, at the point in derivations at which alternating stressability is assigned. Thus we expect that unstressable vowels in such sequences will play the same kind of role in determining alternating stressability as any other underlying unstressable vowels. This prediction is incorrect.

The CV theory of stressability leads to different predictions in the crucial cases. In fact we will see that the CV analysis which was developed in Chapter 4 is fully adequate as it stands to account for the facts of stress assignment in words which contain underlying vowel sequences. A certain amount of evidence from syncope also supports the CV theory. These are important results, since forms in which an underlying unstressable vowel follows another vowel provide the only empirical test that I have been able to find which distinguishes between the CV theory of stressability and the diacritic and metrical alternatives.

The chapter is organized as follows. Section 1 presents the evidence for a rule of Glide Insertion and provides a formal statement of this process within the CV theory. Section 2 motivates and formalizes the rule of Vowel Elision. Section 3 surveys the evidence which bears on the formal statement of E-Mutation. Section 4 explores the ordering relationships which hold between the rules of the first three sections and various

other phonological processes of Passamaquoddy and argues that the implications of these ordering relationships favor the CV theory of the stressable/unstressable distinction over the other models that we have considered.

### 8.1 Glide Insertion

When one stressable vowel is immediately followed by another, the glide /y/ is inserted between them. Within a stem, the first vowel in such a sequence is usually /a/ or /e/, while the second may be /a/, /e/, /i/, or /o/. Other combinations occur in inflected forms, but there are no clear examples of glide insertion after /o/.<sup>1</sup>

If stressable vowels are represented as segments which are linked to V-slots and unstressable vowels as floating segments, then the insertion of /y/ between stressable vowels may be stated as follows.

#### (1) Glide Insertion

$$\emptyset \dashrightarrow \begin{array}{c} C \\ | \\ / \quad V \quad \_ \quad V \\ y \end{array}$$

Although insertion only takes place between morphemes, it is not necessary to mention a morpheme boundary in our statement of this rule, since there are no morpheme-internal vowel sequences.

### 8.1.1 Glide insertion within stems

The insertion of /y/ after roots ending in /a/ is illustrated in (2)-(4). The roots /wisa-/ 'fast, hurriedly' and /nipa-/ are shown first, then the finals /-apasi-/ 'walk (pl.),' /-ahke-/ 'throw, drop, release,' /-ewesto-/ 'speak,' and /-imiya-/ 'attend church,' and then the combinations in which Glide Insertion is applicable. Purely as an orthographic convention, I write inserted /y/ with the preceding morpheme within stems but with the following morpheme when this is an inflectional suffix.

(2) a. wí<sup>h</sup>sá<sup>h</sup>-nto

fast-sing-(3)

'he sings hurriedly'

b. ní<sup>h</sup>pá<sup>h</sup>-hto-n

(3)-night-TI-3IN

'he makes it at night'

(3) a. pé<sup>h</sup>t-apás<sup>h</sup>ə-w-ə<sup>h</sup>k

arrive-pl.walk-3-33PROX

'they (pl.) come walking'

b. l-á<sup>h</sup>hke

thus-throw-(3)

'he throws, drops, releases (something)'

c. təl-ewé<sup>h</sup>sto

ongoing-speak-(3)

'he is speaking'

- d. wít-imíye  
with-attend.church-(3)  
'he attends church'
- (4) a. wísáy-apásá-w-ak  
fast-pl.walk-3-33PROX  
'they (pl.) walk fast'
- b. wísáy-áhka-n  
(3)-fast-throw-PEG  
'he throws it hard'
- c. wísáy-ewésto  
fast-speak-(3)  
'he speaks hurriedly'
- d. nípáy-imíye  
night-attend.church-(3)  
'he goes to midnight mass'

The same pattern of glide insertion is found with roots ending in /e/, but /e/ surfaces as i before the inserted /y/. The roots in (5) and (6) are /kásse-/ 'in' and /máte-/ 'be heard.' For the final /-ote-/ 'move one's gear, change residence,' cf. pét-óte (arrive-move-(3)) 'he moves (his household) in.'

- (5) a. ksé-phówe  
in-run-(3)  
'he runs in'
- b. máté-hto-n  
(3)-be.heard-TI-3IN  
'he hears it being used'



- (6) a. k<sup>́</sup>siy-ap<sup>́</sup>as<sup>́</sup>w-<sup>́</sup>ak  
 in-pl.walk-3-33PROX  
 'they (pl.) walk in'
- b. h-k<sup>́</sup>ssiy-<sup>́</sup>ahka-n  
 3-in-throw-PEG  
 'he throws it in'
- c. m<sup>́</sup>tiy-ew<sup>́</sup>esto  
 be.heard-speak-(3)  
 'he is heard speaking'
- d. k<sup>́</sup>siy-<sup>́</sup>ote  
 in-move-(3)  
 'he moves (his household) in'

Glide insertion also takes place before and after medials. The examples in (7) show the root /mace-/ 'start,' the medial /-amk-/ 'particulate,' and their combination, with inserted /y/.

- (7) a. m<sup>́</sup>ace-ph<sup>́</sup>owe  
 start-run-(3)  
 'he runs away'
- b. p<sup>́</sup>em-amk<sup>́</sup>-ya-k  
 along-particulate-go-3IN  
 'beach'  
 ("where there is a stretch of sand")
- c. m<sup>́</sup>aciy-amk-<sup>́</sup>esso  
 start-particulate-move-(3)  
 'it moves as a mass of pieces'

In (8), the medial /-əte-/ (of uncertain significance) is shown in its basic form, then with inserted /y/ before a final and before another medial.

(8) a. ht-ápkw-əté-hto-n

3-open-?-TI-3IN

'he opens it'

b. h-kápp-ətiy-áhka-n

3-close-?-throw-PEG

'he slams it (door)'

c. ht-ápkw-ətiy-akw-h-ám- n

3-open-?-wood-TI-TI-3IN

'he props it open with a stick'

d. kp-ətiy-ék-ən-əm-òn

close-?-sheet-by.hand-TI-2

'close (sg.) it (with something two-dimensional)!!'

### 8.1.2 Glide insertion in inflection: Conjunct forms

An epenthetic /y/ is inserted in Conjunct verb forms between the final vowel of a stem or theme sign and the initial vowel of a suffix. The suffixes which trigger epenthesis are /-a(n-)/ 1, /-ən/ 2, /-ek/ 11, /-əkw/ 12, and /-ekw/ 22. The environment for epenthesis arises in positive AI and TI forms and in positive TA forms with the theme signs /-i/ 1.OBJ and /-ke/ PASSIVE. The examples in (9) and (10) show the insertion of /y/ before /-an-/. Those in (11) show epenthesis before /-ən/ and /-əkw/. The forms given in (11) reflect the change of /ə/ to i after /y/ and the

replacement of /y/ by h in /iyi/. Both rules are optional for some speakers. (See 3.4 for discussion.)

- (9) a. élamí-ya-lì-t  
away-go-OBV-3AN-(PERF)  
'when the other left'
- b. élamí-ya-yàn  
away-go-1-(PERF)  
'when I left'
- (10) a. skà l-áp-əm-əke-w-àn  
not thus-look-TA-PASS-NFG-1-(SUBJ)  
'if I am not looked at'
- b. l-áp-əm-əki-yàn  
thus-look-TA-PASS-1-(SUBJ)  
'if I am looked at'
- (11) a. élamí-ya-yìn  
away-go-2-(PERF)  
'when you (sg.) left'
- b. l-áp-əm-əki-hìkw  
thus-look-TA-PASS-12-(SUBJ)  
'if we (inc.) are looked at'

In contemporary Passamaquoddy, the schwas of the suffixes /-ən/ 2 and /-əkw/ 12 are inherently stressable, as we can see by the fact that these vowels receive stress, against alternating stressability, in forms like més-ən-əm-ən-p n (get-by.hand-TI-2-PRET) 'when you (sg.) got it' and més-ən-əm-əkw-pən (get-by.hand-TI-12-PRET) 'when we (inc.) got it.' Epenthesis of /y/ in

Conjunct forms can accordingly be attributed to Glide Insertion in Passamaquoddy. For the dialect of Maliseet which Sherwood has described, however, we must postulate a second, morphologically governed rule to account for the insertion of /y/ in Conjunct forms, since /-ən/ and /-əkʷ/ have underlyingly unstressable schwas in this variety of the language. The situation in Passamaquoddy must formerly have been like that in Maliseet: in Proto-Algonquian, /y/ was inserted in stem-formation only between long vowels, but /y/ was added between a vowel-final stem and a vowel-initial ending of the Conjunct Order regardless of vowel length (Bloomfield 1946:93, 101).

### 8.1.3 Further inflectional cases

A number of other occurrences of /y/ in inflectional endings are probably best attributed to Glide Insertion in a synchronic analysis of Passamaquoddy. In verbs, environments in which /y/ is inserted arise through the deletion of the third person suffix /-w/ and perhaps, although this is less clear, through the deletion of the initial /w/ of the second and third person non-singular suffix /-wa(w)/.

Many intransitive stems which end in /a/ are subject to a morphologically governed rule which replaces this /a/ with /e/ before the suffix /-w/.<sup>2</sup> For stems ending in /-ha-/ ~ /-ya-/ 'go,' this change is obligatory. Thus the third person proximate singular non-absentative form of /kəsse-ha-/ 'go in' is ksé-he 'he goes in,' from /kəsse-ha-w/. The corresponding form of

/ə́ləmi-ya-/ 'go away' is ə́ləmi-ye 'he goes away,' from /ə́ləmi-ya-w/. For most other stems which show this change, the rule is optional: ksínóhka ~ ksínóhke 'he is sick' (stem /kə́sinohka-/), htə́ma ~ htə́me 'he smokes' (stem /wə́təma-/).

After AI stems ending in /e/ or /a/, the suffix /-w/ is deleted before endings of the set which includes /-l/ 3.OBV, /-ək/ 33PROX, /-ə/ 33.OBV, /-əl/ 33IN, and a variety of other suffixes which mark gender, number, obviation, and absentativity.<sup>3</sup> When the stem-final vowel is /e/, whether basic or derived from /a/, /y/ is inserted into the resulting vowel sequence in all cases. This /y/ triggers both E-Mutation and the fronting of following /ə/. Thus we have ə́mi-yik 'they (du.) fish' from /ame-w-ək/ and htə́mi-yik 'they (du.) smoke' from /wə́təma-w-ək/; cf. kt-ə́mé-pa 'you (du.) fish,' k-ó́təmá-pa 'you (du.) smoke.' When the stem ends in unmutated /a/, /y/ is inserted before the suffix /-a/ 3AN.ABS, but not before suffixes beginning with /ə/, which drop this vowel instead: we have ksínóhka-yà 'he has gotten sick' from /kə́sinohka-w-a/, but htə́ma-k 'they (du. smoke)' from /wə́təma-w-ək/.

We can account for the insertion of /y/ after /e/ by setting up inherently stressable /ə/ in /-əl/, /-ək/, etc., since these morphemes will then trigger Glide Insertion. We can also attribute the insertion of /y/ between /a/ and /a/ to this rule. We will need an additional rule, however, to account for the fact that /y/ is not inserted after /a/ before the suffixes which begin with /ə/.

If /ə/ is inherently stressable in /-əl/, /-ək/, and the other suffixes of this set, then we cannot attribute the loss of

this vowel after /a/ to Vowel Elision, which affects only unstressable vowels. We will obtain the results that we need, however, if we postulate a rule which deletes stressable /ə/ after /a/ in the appropriate morphemes, provided that this rule is ordered before Glide Insertion. There is evidence for such a rule elsewhere in verbal inflection. For example, /-əl/ and /-ək/ drop /ə/ in h-tək-əm-a-l (3-hit-TA-DIR-3.OBV) 'he hits the other' and k-nəmi-y-á-wa-k (2-see-TA-DIR-22-33PROX) 'you (pl.) see them.' In fact, it appears that the rule in question should be generalized to delete /ə/ after /o/ as well in forms like h-tək-əm-əko-l (3-hit-TA-INV-3.OBV) 'the other hits him' and k-nəmi-y-á-nno-k (2-see-TA-DIR-11-33PROX) 'we (inc.) see them.' After the allomorph /-wi-/ of the negative suffix, however, /ə/ is retained and /y/ is inserted: má te ámé-wi-yik (not EMPH fish-(3)-NEG-33PROX) 'they (du.) do not fish,' má te k-nəmi-y-á-wi-yik (not EMPH 2-see-TA-DIR-NEG-33PROX) 'you (sg.) do not see them.' Apparently, then, stressable /ə/ is deleted only after back vowels.

When the suffix /-ne-/, in any of several functions, is followed by the suffix /-wa(w)/ 22 or 33PROX, the combination is realized as -niya(w)-. The examples in (12)-(14) show /-nno-/ 11 and /-wa(w)/ 33PROX after the direct theme sign /-a/ of TA verbs, then after the inanimate object marker /-ne-/ and after the Subordinative mode marker /-ne-/.

- (12) a. k-n<sup>o</sup>mi-y-á-nno-k  
 2-see-TA-DIR-11-33PROX  
 'we (inc.) see them'
- b. n<sup>o</sup>mi-y-á-wa-l  
 (3)-see-TA-DIR-3.OBV  
 'they see the other'
- (13) a. k-n<sup>o</sup>mi-hto-ne-nno-l  
 2-see-TI-3IN-11-33IN  
 'we (inc.) see them (in.)'
- b. n<sup>o</sup>mi-ht<sup>o</sup>-ni-ya-l  
 (3)-see-TI-3IN-33PROX-33IN  
 'they see them (in.)'
- (14) a. k-táhk-áhs<sup>o</sup>mi-ne-nno  
 2-cold-swim-SUBORD-(ASPECT)  
 'we (du. inc.) would have swum (to cool off)'
- b. h-táhk-áhs<sup>o</sup>mi-ni-yaw  
 3-cold-swim-SUBORD-33PROX-(ASPECT)  
 'they (du.) would have swum (to cool off)'

Here again we can account for the surface occurrence of y between vowels by appealing to Glide Insertion, provided that we postulate a rule which deletes the initial /w/ of /-wa(w)/ after /-ne-/. Since the /w/ of /-wa(w)/ is only replaced by /y/ after /-ne-/, however, we cannot really claim to achieve a significantly simpler overall analysis by supposing that a rule deleting /w/ is involved here rather than a rule of allomorphy which would directly replace /-wa(w)-/ with /-ya(w)/. Compare

kt-áht-əwaləté-wa-k (2-AUG-dish-22-33PROX) 'your (pl.) dishes,' where the initial /w/ of /-wa(w)/ is preserved after a noun stem ending in /e/.

The suffixes /-əl/, /-ək/, etc. trigger Glide Insertion in nouns after /i/ and /e/, but drop /ə/ after /a/, following essentially the same pattern as that described above for AI verbs. Thus /y/ is inserted in əpási-yik 'trees' (from /əpási-ək/) and wələtí-yik 'dishes' (from /əwaləte-ək/), but /ə/ is deleted in póhtáya-k 'bottles' (from /pohtaya-ək/), as noted in 7.1.

Sherwood (1983a, 1983b:29) has postulated stems ending in /w/ for nouns which I have interpreted as based on stems ending in /e/ or /a/. There is historical justification for such a proposal in many cases, but the synchronic grammar of Passamaquoddy must distinguish a class of nouns which show the inflectional pattern of wələt and póhtày from another class which clearly have stems in final /Vw/ but are inflected on a different pattern. For example, the unsuffixed singular form of the noun əpásénta 'sundog' fails to undergo Final Vowel Deletion, while the proximate plural form əpáséntáw-ək has w before the suffix -ək. Both facts can be explained by setting up a stem /əpáséntaw-/ which drops /w/ word-finally after Final Vowel Deletion. The noun péhke 'shed' also fails to undergo Final Vowel Deletion and has w before the locative suffix /-k/, which here surfaces with epenthetic /ə/: péhkéw- k 'shed (loc.)'. Here again the facts point to a stem ending in /w/: /péhkew-/. There appear to be only a few native nouns in this class, but vowel-final borrowings are productively assimilated to this pattern of



inflection: káhpe 'coffee,' pl. káhpew-əl 'cups, jars, etc. of coffee'; piye 'beer,' pl. piyéw-əl; tí 'tea,' pl. tíw-əl. Proper names of this type are particularly common: píli 'Billy,' obv. píliw-əl; máli 'Mary,' obv. máliw-əl; lóla 'Lola' (a family name and a man's given name, from French Laurent), obv. lólaw-əl. Synchronically, then, it appears to be best to derive nouns like walət and póhtáy from vowel-final stems. Since there appears to be no evidence for a synchronic class of stems in final /iy/ alongside the class of stems ending in /i/, I assume that /y/ is inserted by Glide insertion both in épasí-yik and in walətí-yik, with i for stem-final /e/ in the latter by E-Mutation.<sup>4</sup>

## 8.2 Vowel Elision

When a stressable vowel is immediately followed by an unstressable vowel, the unstressable vowel is deleted. In some cases we would expect this deletion in any event, since one or another of the syncope rules is potentially applicable. Yet other cases of deletion in this environment do not fall under any of the processes of syncope that we have considered in preceding chapters. Thus an additional rule is required. If we assume as before that unstressable vowels are segments without timing slots, then the new rule may be stated as follows.

(15) Vowel Elision

$$\begin{array}{c} \text{V} \\ \textcircled{\text{v}} \text{ ---} \rightarrow \text{ } \emptyset \text{ / } | \\ \text{X} \text{ ---} \end{array}$$

The vowel which triggers deletion is usually /a/ or /e/. The rule is applicable in a variety of stem-internal contexts, but there are no clear examples of its application in inflectional environments.

The examples in (16)-(19) show the finals /-ən-/ 'by hand,' /-əlohk-e-/ 'work,' and /-ələn-/ 'rain' and the medial /-əsit-/ 'foot' first with initial /ə/ after a non-syllabic and then with loss of this /ə/ after a vowel. As we noted in 5.1, morphemes like these must begin with /ə/ in their underlying forms, since we would expect them to trigger the insertion of connective /i/ after a non-syllabic if their consonant-initial forms were basic.

(16) a. mēm-ən-a-1

(3)-enough-by.hand-DIR-3.OBV

'he can and does reach the other (with his hand)'

b. nəkka-n-a-1

(3)-all-by.hand-DIR-3.OBV

'he takes all of the other'

(17) a. síw-əlohk-e

tired-work-AI-(3)

'he is tired of working'

b. wisa-lóhk-e

fast-work-AI-(3)

'he works hurriedly'

- (18) a. p<sup>é</sup>tá<sup>k</sup>-əlan  
 thunder-rain-(3)  
 'there is a thunder shower'
- b. má<sup>é</sup>-lan  
 start-rain-(3)  
 'it starts to rain'
- (19) a. pa<sup>nə</sup>w-ə<sup>sít</sup>-e  
 open(?)-foot-AI-(3)  
 'his feet point out when he walks'
- b. w<sup>é</sup>wtó<sup>hke</sup>-sít-e  
 inward(?)-foot-AI-(3)  
 'his feet point in when he walks'

Now we know independently from examples like kwákw-sít-e (dirty-foot-AI-(3)) 'he has dirty feet' that the initial /ə/ of /-sít-/ may be deleted by Syncope I. Presumably, then, either syncope or Vowel Elision could be responsible for the deletion of /ə/ in this medial in (19b). None of the syncope rules can account for the deletion of /ə/ in (16)-(18), however, since word-internal /ə/ is subject to syncope before sonorant consonants only where Geminate Deletion is applicable. For these cases, then, a rule like (15) is required.

A similar argument can be made on the basis of exceptions to Syncope I. The finals /-əka-/ 'dance' and /-əs-/ 'by cutting edge' are sporadic or optional exceptions to this rule, while /-əpi-/ 'sit' and /-ətēmi-/ 'cry' never undergo it. All four of these finals consistently drop /ə/ after a vowel, however, as illustrated in (20)-(23).

- (20) a. pám-ǎka  
 ~ pám-ka  
 along-dance-(3)  
 'he dances'
- b. máwé-ka-k  
 group-dance-(3)  
 'they (pl.) dance together'
- (21) a. ht-ǎl-ǎs-a-l  
 ~ ht-ǎl-s-a-l  
 3-thus-cut-DIR-3.OBV  
 'he cuts the other (with a knife)'
- b. h-támí-kǎsiyé-s-a-l  
 3-in.two-fingernail-cut-DIR-3.OBV  
 'he cuts the other's fingernails'
- (22) a. át-ǎpo  
 change-sit-(3)  
 'he changes seats'
- b. kwsǎka-po  
 across-sit-(3)  
 'he sits across something'
- (23) a. wík-ǎtémó  
 like-cry-(3)  
 'he likes to cry'
- b. máte-témó  
 be.heard-cry-(3)  
 'he is heard crying'

Here again we must be dealing with underlying /ə/, since epenthetic /ə/ would be expected to undergo Syncope I regularly. But none of the rules of syncope can account for the fact that deletion of /ə/ after a vowel is both permitted and obligatory in all such cases.

Unstressable /i/ and /a/ are also consistently deleted after a vowel. Examples showing the resulting alternations in the medials /-ihte-/ 'strike' and /-ihtakw-/ 'sound' and the finals /ihkət-/ 'ebb' and /-ihkəw-/ 'by body, by vehicle' are given in (24)-(27). For syncope of /i/ in these morphemes, see 6.1

(24) a. wíə̀k-ihté-hsin

extremely-strike-lie-(3)

'he got badly hurt in a crash'

b. nəká-hte-ləw-à-kk

(3)-all-strike-shoot-DIR-33AN.ABS

'he shot all of the others (abs.)'

(25) a. h-cípək-ihtákw-so-w-ám-a-l

3-loud-sound-AI-DA-TA-DIR-3.OBV

'he talks very loudly to the other'

b. náska-htákw-so-w-ám-a-i

(3)-discourage-sound-AI-DA-TA-DIR-3.OBV

'he hollers at the other discouragingly'

(26) a. álɔm-íhkət

away-ebb-(3)

'the tide goes out'

b. mácé'-hkət

start-ebb-(3)

'the tide starts to go out'

(27) a. ht-álɔm-íhkəw-a-l

3-away-by.body-DIR-3.OBV

'he forces the other to go away by following him'

b. kát əp pc-íhte-hkəw-à-w

not COND accidentally-strike-by.vehicle-3PASS-NEG

'he would not get hit (by a car)'

Comparable examples are given in (28) and (29) for the finals /-ahte-/ 'be located' and /-ahki/ 'land.' For syncope in these morphemes, see 6.2. The initial in (29b) is the stem of the noun míhkəm 'Micmac' (pl. míhkəma-k).

(28) a. ksí písk-alək-áhte

intense dark-hole-located-(3)

'it is very dark inside'

b. kwsáká-hte

across-located-(3)

'it is located across something'

c. ksé-hte

in-located-(3)

'it is located partway in'

- (29) a. ní<sup>́</sup>pə<sup>ə</sup>n-ahkí<sup>̀</sup>-k  
 summer-land-LOC  
 'where it is always summer'
- b. mí<sup>́</sup>hkə<sup>ə</sup>ma-hkí<sup>̀</sup>-k  
 Micmac-land-LOC  
 'Micmac territory (loc.)'

The deletion of unstressable /o/ after vowels may be attested by forms like wík<sup>́</sup>pí<sup>́</sup>-hke (brown.ash-acquire-(3)) 'he collects brown ash' and mó<sup>́</sup>wíné<sup>́</sup>-hke (bear-acquire-(3)) 'he hunts bear,' if the underlying form of 'acquire' is /-ohke-/, as suggested in 6.3.

As we might expect, we occasionally find forms which reflect the reanalysis of a synco<sup>o</sup>pat<sup>^</sup>ing vowel as an inherently stressable vowel, so that Glide Insertion rather than elision takes place: nó<sup>́</sup>tiy-ahká<sup>́</sup>tə<sup>ə</sup>m (out-marry-(3)) 'he is married out of his group' (cf. nó<sup>́</sup>té<sup>́</sup>-hte (out-located-(3)) 'it sticks out'), ksá<sup>́</sup>kay-áskot-è<sup>̀</sup>-w (across-field-PART-PART) 'across a field' (with /kə<sup>ə</sup>sə<sup>ə</sup>ka-/, variant of /kwə<sup>ə</sup>sə<sup>ə</sup>ka-/ 'across'). Examples of this type appear to be considerably less common, however, than forms which show the retention of a potentially synco<sup>o</sup>pat<sup>^</sup>ing vowel after a non-syllabic.

Because unstressable /i a o/ are consistently deleted after a vowel, we are free to formulate Vowel Elision so that it is applicable to any unstressable vowel. We do not have the kind of evidence for the role of Vowel Elision here, however, that we have in cases involving /ə/, since there are no examples of unstressable /i a o/ which escape syncope before /hC/. There appears to be no way to determine whether the deletions

illustrated in (24)-(29) should be attributed to Vowel Elision or to Syncope II.

There is indeterminacy of a different sort in the analysis of alternations between initial ə and zero in inflectional suffixes. In the last chapter we saw reason to believe that a rule of epenthesis inserts unstressable /ə/ between non-syllabics at the boundary of an inflectional suffix. Given this rule, it is impossible to demonstrate that Vowel Elision is applicable in inflectional morphemes. The patterns of alternation which would result from elision are the same as those which result from epenthesis: zero after vowels, ə after non-syllabics (alternating with zero in syncope). None of our tests for underlying morpheme-initial /ə/ are applicable to inflectional endings: insertion of connective /i/ is not expected before non-syllabics; no inflection suffixes correspond to stem-initial elements which can undergo Initial Change; there are apparently no relevant cases of exceptions to syncope. There are not even any relevant alternations in suffixes involving vowels other than /ə/. Since there is motivation for the application of Vowel Elision only within stems, it seems best to assume that contexts for the application of this rule are limited to these stem-internal cases.

### 8.3 E-Mutation

A number of examples were given in section 1 which illustrate the change of /e/ to /i/ before inserted /y/, a change which I attribute to the rule of E-Mutation. This change takes place regardless of the environment in which /y/ is inserted: it



affects stem-internal /e/, stem-final /e/, and /e/ in inflectional suffixes.

Neither basic /ey/ nor /ey/ derived by Initial Change is subject to mutation: píl-éya-k (new-NOUN.FINAL-33PROX) 'new ones (prox. an.),' éyi-t (be.located-3AN) 'where he is'; cf. íyo (be.located-(3)) 'he is (there).' In cases of these kinds, however, /ey/ is always morpheme-internal, while we may assume that a morpheme boundary follows /e/ before inserted /y/. Elsewhere, /ey/ arises across a morpheme boundary only where /-y-/ represents underlying /-ha-/, the allomorph of /-ha-/ ~ /-ya-/ 'go' which is used after /a/ and /e/. Here again /e/ is stable, surfacing unchanged in forms like máce-y-yik (start-go-(3)-33PROX) 'they (du.) leave' and máce-y-yà (start-go-(3)-3ABS) 'he has left.' But some speakers permit or prefer alternates with -h- for -y- in these forms (máce-h-hik, máce-h-yà), and -y- is in paradigmatic alternation with -ha- and -he- in these verbs for all speakers: n-máca-ha (1-start-go) 'I leave,' máce-he (start-go-(3)) 'he leaves.' I tentatively conclude, then, that -y- is derived from /-h-/ in forms like máce-y-yà by a rule which follows E-Mutation. Thus we can state E-Mutation as a general rule, one which affects any /e/ which is followed by /y/ across a morpheme boundary.

The formulation of E-Mutation for which I will argue in this section is the following.

(30) E-Mutation

V	ø	C
i	-->	/ + i
e	i	— y

Two principal claims are embodied in this statement of the rule: (1) the output of E-Mutation is a floating vowel; (2) /e/ becomes /i/ directly in E-Mutation, rather than passing through an intermediate stage such as /ə/. Evidence for the first of these claims comes from the fact that the output of E-Mutation behaves in stress assignment and (perhaps) syncope like underlying unstressable vowels. Evidence for the second claim comes from forms in which unstressable i is derived from underlying /i/. The fact that there are no surface alternations which call for a rule changing /ə/ to /i/ before /y/ also weighs against postulating /ə/ as an intermediate stage in the derivation of i from /e/.

As it stands, however, the statement of E-Mutation given in (30) fails to account for the assimilatory character of this process. In a theory in which segments are regarded as unstructured bundles of features, we have no way to explain why the output of E-Mutation is a segment which shares all of the feature specifications of the trigger of the rule. We cannot say that the rule spreads the features of /y/ onto the slot occupied by /e/ in its input, since the rule must delete this slot.

An adequate solution to this problem will undoubtedly require an appeal to a more structured representation of the segment. For example, if we follow Clements (1985) in postulating a structure for the segment in which features branch

from a root node which is distinct from the timing slots of the CV tier, then we can analyze E-Mutation as a process by which the features of /y/ spread onto the root node of a preceding /e/ at the same time as the associated V-slot is deleted. I will not attempt to settle this matter here, however, and note only that a feature-spreading account of this type would be consistent with the two claims stated above.

If the view of E-Mutation for which I will argue is correct, then floating /i/ as well as floating /ə/ can appear in phonological representations after the application of the rules of stress assignment and syncope. Since these occurrences of /i/ must receive timing slots in order to appear in phonetic representations, I assume that Schwa Support, like V-Epenthesis, Final Syllable Epenthesis, Schwa Deletion I, and Schwa Deletion II, must be generalized so that it is applicable to any floating [-consonantal] segment.

### **8.3.1 The output of E-Mutation is a floating vowel**

By now the phonological patterning which is characteristic of underlying unstressable vowels is familiar: such segments figure into syllable counts for stress placement when they follow clusters other than /hC/, when they are in even-numbered positions for alternating stressability, etc. When none of the conditions requiring stressability holds, they are invisible to the stress rules and may be subject to syncope if further conditions are met.

The examples in (31)-(33) show that i follows this pattern of behavior in stress assignment when it reflects root-final /e/ before inserted /y/. The first example in each pair shows that /e/ is a stressable vowel where it is not subject to mutation. In (31b) and (32b), /i/ in the output of mutation remains an unstressable vowel, since it follows a stressable vowel and a single consonant. In (33b), however, the /i/ which results from mutation surfaces as a stressable vowel by alternating stressability. (For root-final i from /e/ which is stressable because of a preceding cluster, see (6a,d).)

(31) a. mətapé-hte  
 downhill-located-(3)  
 'it is situated facing downhill'

b. mətápiy-apasə-w-ək  
 downhill-pl.walk-3-33PROX  
 'they (pl.) walk downhill'

(32) a. nóteé-ph-a-l  
 (3)-out-carry-DIR-3.OBV  
 'he carries the other out'

b. nótiy-apasə-w-ək  
 out-pl.walk-3-33PROX  
 'they (pl.) walk out'

(33) a. wəsəké-hte  
 empty-located-(3)  
 'it (e.g. a house) is unoccupied'

b. wásakíy-atəp

empty-head

'skull'<sup>5</sup>

The situation is similar where the final /e/ of a verb stem undergoes mutation, whether the trigger is the /y/ inserted before /-əl/, /-ək/, etc. or the /y/ which appears before the vowel-initial Conjunct endings. In (34a), the surface i which represents the /e/ of /-əlók-e-/ 'work' remains unstressable because the preceding cluster is /hk/. In (34b), i is unstressable because it is in third position for alternating stressability in the intermediate representation /watəmi-yəl/, from underlying /watəma-w-əl/. In (34c), however, the output of F-Mutation surfaces as stressable i because the last preceding vowel is the syncopeing /ə/ of /-əpe-/ 'liquid.' (Compare psən-pe (full-liquid-(3)) 'it (an.) is full of liquid.')

(34) a. étəl-əlók-i-yekw

ongoing-work-AI-22

'you (du.) who are working'

b. htəmi-yil

~ htəmi-hil

smoke-(3)-3.OBV

'the other smokes'

c. psən-pi-hik

full-liquid-33PROX

'they (du.) are full of liquid'

The facts are again the same for noun stems ending in /e/ where /y/ is inserted before vowel-initial suffixes. Unstressable i surfaces for underlying /e/ in (35) and (36), where none of the conditions requiring stressability holds. In (37), surface i is stressable by alternating stressability, while the i which follows /sk/ in (38b) is stressable because of this cluster even though the last preceding vowel is an inherently stressable / /.

(35) a. n-ítapé-nno-k  
 1-friend-11-33PROX  
 'our (exc.) friends'

b. n-ítápii-yik  
 1-friend-33PROX  
 'my friends'

(36) a. pəsənóte-kəl  
 basket-33IN.ABS  
 'baskets (abs.)'

b. pəsənóti-yil  
 basket-33IN  
 'baskets'

(37) a. ht-áh-cikəné-m-əl  
 3-AUG-apple-PCSS-3.OBV  
 'his apple'

b. cikəni-yik  
 apple-33PROX  
 'apples'

- (38) a. wánáske-k  
 wing-LOC  
 'wing (loc.)'
- b. wánaskí-yil  
 (3)-wing-3.OBV  
 'his wing'

Finally, we can see the effect of alternating stressability on the status of the i derived from the /e/ of /-ne-/ in (39), where this segment appears as the first, second, third, and then fourth vowel in a series within which alternating stressability holds. (The ə of surface -əni- is epenthetic.)

- (39) a. míc-oltí-ni-ya  
 (3)-eat-PL-3IN-33PROX  
 'they (pl.) eat it'
- b. má hâpc kèkw míl-a-w-əní-ya  
 not again something (3)-give-DIR-NEG-PEG-33PROX  
 'they will not give the other anything again'
- c. h-páwat-ə-m-əni-ya  
 3-want-TI-3IN-33PROX  
 'they want it'
- d. ht-əl-ákwəs-ə-m-əni-ya  
 3-thus-cook-TI-3IN-33PROX  
 'they cook it thus'

We see, then, that the segment which results from the application of E-Mutation counts as stressable where an underlying unstressable vowel counts as stressable and is

invisible to the stress rules where an underlying unstressable vowel remains unstressable. Clearly, the output of E-Mutation is an unstressable vowel. In the terms of the CV theory of stressability, this means that E-Mutation deletes the V-slot which is underlyingly associated with /e/ in the triggering environment.

This analysis of E-Mutation receives further support from the fact that the segment which results from mutation appears to be subject to syncope between two occurrences of /y/. If we formulate E-Mutation so that its output is a floating /ə/, then this result can be predicted on the basis of the statement of Geminate Deletion given in 5.7.7, since the latter rule deletes floating /ə/ between identical non-syllabics. But geminate deletion may easily be generalized so that it will delete any floating vowel in appropriate environments, so the evidence of syncope really only bears on the status of the output of E-Mutation as a floating vowel, not on the identity of this segment.

The environment for syncope arises in the final /-ya-/ 'go,' the alternant of /-ha-/ ~ /-ya-/ which is used after /i/, and in two other finals which are probably etymologically related to this one: /-ayya-/ ~ /-ahya-/ 'play' and the plural final /-ya-/.<sup>6</sup> The obligatory nature of the shift of /a/ to /e/ before the third person suffix /-w/ was noted for /-ya-/ 'go' in section 1. This shift is also obligatory for /-ayya-/ ~ /-ahya-/ and for /-ya-/ PLURAL. Thus we have nt-ətəl-ayya-pən ~ nt-ətəl-ahya-pən (1-ongoing-play-11) 'we (du. exc.) are playing,' but təl-áyye ~ təl-áhye (ongoing-play-(3)) 'he is playing'; kt-əpi-yà-pən (2-



sit-PL-11) 'we (pl. inc.) sit,' but má te ʔpí-ye-wì-kk (not EMPH sit-PL-(3)-NEG-33AN.ABS) 'they (pl. abs.) are not sitting -(there) anymore.' When Glide Insertion is applicable in a form in which /a/ has shifted to /e/, the inserted /y/ triggers E-Mutation and the potential for syncope arises.

We find yy as a result of syncope where we would otherwise expect iy in third person forms of stems made with either of the finals with the shape /-ya-/. Speakers who have h for y between occurrences of i have hh for yy here. Thus with /-ya-/ 'go' we find ʔlámí-y-yik ~ ʔlámí-h-hik (away-go-(3)-33PROX) 'they (du.) go away.' With /-ya-/ PLURAL we have ʔpí-y-yik ~ ʔpí-h-ik (sit-PL-(3)-33PROX) 'they (pl.) sit.' The output of E-Mutation is not subject to deletion, however, in stems made with /-ayya-/ ~ /-ahya-/. Instead, the final vowel of this element surfaces as stressable i: tál-ayyí-yik ~ tál-ahhí-hik. (ongoing-play-(3)-33PROX) 'they (du.) are playing.' Presumably i is stressable here because of the preceding cluster. The fact that a stressable vowel surfaces while an unstressable vowel is deleted between occurrences of /y/ confirms that deletion in this environment has the character of syncope.<sup>7</sup>

While it seems plausible to attribute deletion in ʔlámí-y-yik and ʔpí-y-yik to Geminate Deletion, some problems remain with this interpretation of the data. Chief among these is the fact that deletion takes place at comparable points in verbs formed with /-ha-/ rather than /-ya-/: ʔkwá-y-yik ~ ʔkwá-h-hik (ashore(?)-go-(3)-33PROX) 'they (du.) run their canoe up on shore.' (Compare ʔkwé-he 'he runs his canoe up on shore,' ʔkwa-ha-t 'when he ran his canoe up on shore.') We noted above that

it is desirable, for the analysis of E-Mutation, to suppose that yy is derived from /hy/ in forms like mácé-y-yik 'they (du.)-leave' and máce-y-ya 'he has left.' But this proposal entails that deletion of unstressable /i/ must take place between /h/ and /y/, with mácé-y-yik coming from an intermediate representation like /mace-hi-yək/. While we can, of course, write a rule to carry out this deletion, it is not clear that Geminate Deletion can or should be revised to account for such cases.<sup>8</sup> Major problems in the analysis of verbs in /-ha-/ ~ /-ya-/ remain unresolved at this time.

### 8.3.2 The output of E-Mutation is /i/

There is very little direct evidence which bears on the feature composition of the output of E-Mutation. Historically, this segment was probably \*ə. In fact there is nothing to bar us from setting up /ə/ as an intermediate stage in the change of /e/ to i in a synchronic analysis of Passamaquoddy, since the sequence əy does not occur on the surface. A rule deriving iy from /əy/ would complete the derivation of i from /e/ and provide an explanation for the absence of surface əy at no extra cost. But while it is true that surface əy does not occur, there are also no surface alternations between ə and i which would motivate a rule changing /ə/ to /i/ before /y/. Apparently the only occurrences of /ə/ which would undergo this rule are those which are putatively derived by E-Mutation.<sup>9</sup>

Moreover, there are other occurrences of unstressable i which are not derived from /e/. We have already seen in Chapter 6 that underlyingly unstressable /i/ is fairly common before /hC/, but these segments either undergo syncope or surface as stressable vowels. Surface unstressable i occurs only before y (or h derived from /y/), but may be non-alternating or may alternate with stressable i rather than with e.

Cases of the first kind appear to be uncommon, although the status of many occurrences of i before y remains to be determined. One clear example is the dependent noun stem -əniyakən 'head.' The initial ə of this element is always treated as stressable, while the following i is consistently invisible to the stress rules. Thus we have w-əniyakəní-ne (3-head-ache-(3)) 'he has a headache,' with initial stress and no stress in niyak, showing that this sequence contains only a single stressable vowel. Since the stem -əniyak n has a constant surface shape, there is no obvious reason why its underlying form should not also be /-əniyak n/, with underlying unstressable /i/.

More interesting is the fact that some occurrences of unstressable i represent basic stressable /i/. In fact it appears that underlying /i/ is subject to a rule which closely resembles E-Mutation, becoming an unstressable vowel before /y/. By no means all occurrences of i before y show the behavior of underlying unstressable vowels: i before y is stressable, for example, in ímiya-n (pray-UNSPEC) 'mass is said' and sapí-ye (though-go-(3)) 'he, it goes through.' But i representing underlying /i/ receives the treatment of an underlying unstressable vowel before inserted /y/. For example, the final

/i/ of /wiki-/ 'dwell' is a stressable vowel in (40a), but is skipped over in assigning stress in (40b), so that only the antepenult receives stress in the latter example. Basic /i/ in /-ətemi-/ 'cry' is treated as unstressable in (41b). The /i/ of the negative suffix /-wi-/ shows similar behavior in (42).

(40) a. wíki-li-n  
 (3)-dwell-OBV-SUBORD  
 'the other dwells (Subordinative)'

b. wíki-yekw  
 dwell-22  
 'where you (du.) dwell'

(41) a. més-ətémí-t  
 why-cry-3AN  
 'why is he crying?'

b. més-ətémí-yin  
 ~ mes- temí-hin  
 why-cry-2  
 'why are you (sg.) crying?'

(42) a. má kisi-hpí-wi  
 not can-eat-(3)-NEG  
 'he can't eat'

b. má kisi-hpí-wi-hil  
 not can-eat-(3)-NEG-3.OBV  
 'the other can't eat'

There is even evidence for syncope of basic /i/ between /y/ and /y/ from forms like éy-yin (be.located-2) 'where you (sg.) are'; cf. éyi-t (be.located-3AN) 'where he is.'

Like i derived by E-Mutation, underlying /i/ before inserted /y/ surfaces as an unstressable vowel only where underlying unstressable vowels retain this status. Thus /i/ surfaces as a stressable vowel in étót-elámí-yek (extreme-laugh-11) 'we (du. exc.) laugh really hard (Conjunct),' where the last preceding vowel is an unstressable ə. (Compare étot-élami-t (extreme-laugh-3AN) 'he laughs really hard (Conjunct).') A similar situation holds in i-stem nouns: stem-final /i/ surfaces as an unstressable vowel in ípísi-yil ~ ípísi-hil (switch-33IN) 'switches, whips,' but as a stressable vowel in wíkpi-yik ~ wíkpi-hik (brown.ash-33PROX) 'pieces of brown ash' and ápási-yil ~ ápási-hil (stick-33IN) 'sticks'; cf. ht-ípísi-m 'his switch,' n-wíkpi-m 'my brown ash,' ht-ápási-m 'his stick.'

It seems pointless to derive surface i from underlying /i/ via /ə/ in forms like wíkpi-yekw 'where you (du.) dwell' and ípísi-hil 'switches.' But if we choose to represent i as /i/ throughout the derivations of these forms, then we must postulate intermediate representations for them in which floating /i/ stands before /y/. Given such representations for these cases, it seems reasonable to suppose that the output of E-Mutation is also of this form.

In fact it seems likely that E-Mutation should be generalized so that it applies to both /e/ and /i/ before inserted /y/. Several unresolved problems stand in the way of an evaluation of this proposal, however. In particular, it appears

that /i/ generally remains stressable where it is followed by /y/ across a morpheme boundary but /y/ is the TA final /-y-/ or the initial segment of /-ya-/ 'go': h-kí-sí-y-a-l (3-past-TA-DIR-3.OBV) 'he made the other,' pé-cí-ye (arrive-go-(3)) 'he arrives.' There are some apparent inconsistencies in cases of this kind, however. In ó-li-ye (thus-go-(3)) 'he goes there,' we find antepenultimate stress and the retention of word-initial /ə/, both pointing to unstressable /i/ in this form. Yet in the corresponding dual form lí-h-hik (thus-go-(3)-33PROX) 'they (du.) go there,' both penultimate stress and syncope of initial /ə/ show that /i/ is treated as stressable before /-ya-/. The full set of conditions which govern the distribution of unstressable i has yet to be worked out.

#### 8.4 Questions of rule order

We come now to the question of the relative order of application of Glide Insertion and Vowel Elision. We will see that the assumptions of the diacritic and metrical theories of stressability require us to order Glide Insertion before the rules which establish the distribution of stressable and unstressable vowels, but to order Vowel Elision after these rules. It follows that Glide Insertion must precede all of the rules which eliminate underlying sequences of a stressable and an unstressable vowel. Thus Glide Insertion must be formulated so that it can distinguish these sequences from sequences of two stressable vowels, since it is only in the latter that /y/ is inserted. To make this distinction, the rule must refer to the

feature [strong] if we adopt the diacritic theory, or to the presence of lexical accents if we take a metrical approach.

Within the CV theory of stressability, the relative order of Glide Insertion and Vowel Elision is not clearly determined. Ordering Glide Insertion before Vowel Elision requires no appeal to diacritic features or accents, however, since Glide Insertion as formulated in section 1 is simply not applicable in a sequence of a stressable and an unstressable vowel.

If Vowel Elision follows the assignment of stressability in the diacritic and metrical theories, then the input to the rules which account for alternating stressability in these frameworks must contain sequences of a stressable and an unstressable vowel. Both of these theories postulate rules which assign alternating stressability by counting off unstressable vowels in pairs. The CV theory, on the other hand, derives alternating stressability from properties of syllabification. We will see that these procedures lead to different results where a post-vocalic unstressable vowel is involved, and that the predictions of the CV theory are correct.

#### **8.4.1 Vowel Elision and VHV Assimilation**

The crucial evidence for the ordering of Vowel Elision comes from its interaction with VHV Assimilation, the rule which was introduced in 5.5.2 to account for the fact that the first vowel in a sequence of the form /VhV/ comes to take on the features of

the second. We begin, then, by looking at morphemes which can undergo either rule.

The TA final /-əhol-/ 'ferry, transport by boat,' its TI mate /-əhot-/, and the AI final /-əhəm-/ 'swim' begin with syncopating vowels, as we can see from (43)-(45). (I have no example in which an initial vowel is directly attested in /-əhot-/, but note that we would expect noci- for not- in (44) before a final whose underlying form began with a non-syllabic.) For the choice of /ə/ as the underlying initial vowel in these morphemes, see 5.5. This segment is always subject to VHV Assimilation when it is not deleted.

(43) a. h-sákh-ohól-a-l

3-into.view-ferry-DIR-3.OBV

'he ferries the other into view'

b. ht-ál-hól-a-l

3-around-ferry-DIR-3.OBV

'he guides the other around'

(i.e. takes the other around by boat  
on a hunting trip)

(44) nót-hot-áhsi-t

occupation-ferry-AI-3AN

'guide (on a hunting trip)'



- (45) a. sákh-<sup>h</sup>həm  
 into.view-swim-(3)  
 'he swims into view'
- b. áh-<sup>h</sup>həm  
 around-swim-(3)  
 'he swims around'

The initial vowels of these finals are deleted, as expected, after vowel-final roots; but assimilation does not take place in the resulting /VhV/ sequences:

- (46) a. wísa-hól-a-l  
 (3)-fast-ferry-DIR-3.OBV  
 'he transports the other hurriedly by boat'
- b. máce-hól-a-l  
 (3)-start-ferry-DIR-3.OBV  
 'he carries the other away by boat'
- c. máce-hót-o-n  
 (3)-ferry-TI-3IN  
 'he carries it away by boat'
- d. kw<sup>h</sup>sáka-həm  
 across-swim-(3)  
 'he swims across'

Presumably it is the underlying presence of the deleted vowels which blocks the application of VHV Assimilation in these forms. For example, assimilation does not take place in the derivation of (46d) because the /a/ of /kw<sup>h</sup>sáka-/ is not adjacent to the /h/

of /- h m-/ at the stage in the derivation of this form when it is represented as shown in (47).

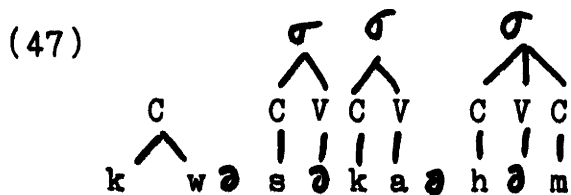

Since initial /ə/ is clearly subject to Syncope II in /-əhol-/, /-əhot-/, and /-əh m-/, there is no way to know whether the deletion of /ə/ in (46a-d) is due to syncope or to Vowel Elision. One point is clear, however: both Syncope II and Vowel Elision must be ordered after VHV Assimilation. If either of these rules were applied first, the initial vowels of /-əhol-/, /-əhot-/, and /-əh m-/ would be deleted before the application of assimilation, and we should have \*wisoholal, \*macoholal, etc., with matching vowels on either side of h.

#### 8.4.2 VHV Assimilation and Schwa Deletion III

In an analysis in which both stressable and unstressable vowels have V-slots (or one in which no distinction is drawn between a segmental tier and a timing tier), we can determine the ordering of VHV Assimilation by considering its interaction with the rule which deletes unstressable /ə/ between /h/ and /m/. Under the CV theory of stressability, however, we apparently cannot establish the relative order of VHV Assimilation and Schwa Deletion III, the formal statement of syncope between /h/ and /m/ which was proposed in 5.6. The relative order of VHV

Assimilation with respect to several other rules remains undetermined as well.

Alternations like those shown in (48) constrain proposals concerning the relative order of syncope and VHV Assimilation under the assumptions of the diacritic and metrical theories of stressability because assimilation is only triggered by stressable vowels.

- (48) a.  $\acute{i}k\grave{a}t\acute{e}h\grave{a}m$  (/ikətehən-w/)  
yawn-(3)  
'he yawns'
- b.  $\acute{i}k\grave{a}t\acute{e}hm-ok$  (/ikətehəm-w-ək/)  
yawn-(3)-33PROX  
'they (du.) yawn'

Note that assimilation does not take place in underlying /ehə/ where /ə/ is subject to syncope. If VHV Assimilation follows syncope, we do not have to say anything about this restriction in our statement of the rule. Syncopated /ə/ is simply not present in the structure to which the assimilation rule applies. Ordering VHV Assimilation before syncope would require us to complicate our statement of the rule by specifying that the trigger must be [+strong] in the diacritic account, or requiring the trigger to bear at least minimal stress if we take the metrical approach.

The evidence of forms like those in (48) does not allow us to determine the relative order of syncope and assimilation in the CV theory because no complication of the statement of VHV Assimilation is needed to exclude unstressable /ə/ as a trigger.

The representations of íkətéh-m-ok before and after the application of Schwa Deletion III are shown in (49).

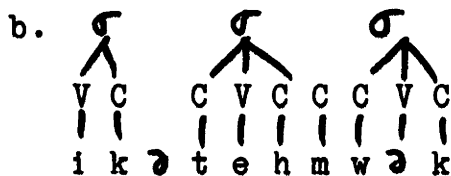
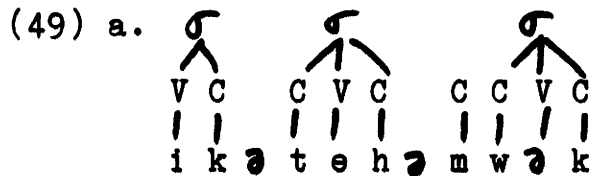

If VHV Assimilation is formulated as a rule which spreads the features of one V-slot onto another, as suggested in 5.5.2, then it is no more applicable in (49a) than in (49b). Since floating /ə/ is not associated with a V-slot, its features will not spread.

Now VHV Assimilation must at least follow Final Syllable Epenthesis under the CV theory, since it is the latter rule which supplies the V-slot for the last vowel in (50), and this V-slot is required for the application of assimilation in the derivation of íkətéh-m.

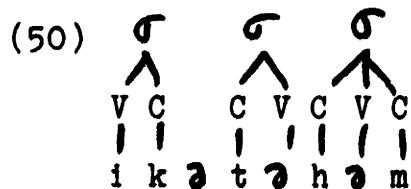

We can make a considerably stronger statement in the diacritic and metrical theories, however. Since VHV Assimilation must follow syncope between /h/ and /m/, it must in general be ordered after the rules which determine the distribution stressable and

unstressable vowels in these frameworks. In particular, VHV Assimilation must follow the rule which determines alternating stressability, however it is stated, since vowels which are stressable in accordance with this principle are not subject to syncope.<sup>10</sup>

### **8.4.3 Glide Insertion and Vowel Elision**

It is clear that Glide Insertion must precede E-Mutation, since some (perhaps all) occurrences of /y/ which trigger E-Mutation result from the application of Glide Insertion. It is also clear that E-Mutation must precede the assignment of stressability to underlying unstressable vowels, or at least that part of the process which accounts for the effect of clusters on stressability and for alternating stressability, since the unstressable vowels which result from the application of E-Mutation receive the same treatment as underlying unstressable vowels in these respects. From these considerations, we can conclude that Glide Insertion must precede syncope, since all of the rules which determine the distribution of stressable and unstressable vowels must precede any of the rules of syncope. These ordering relationships appear to hold independently of our choice of a framework for the representation of the stressable/unstressable distinction.

Now we determined in 8.4.1 that Vowel Elision must follow VHV Assimilation, since elision does not feed the assimilation process. Furthermore, we saw in 8.4.2 that an optimal

formulation of VHV Assimilation under the assumptions of the diacritic and metrical theories of stressability requires us to order this rule after the rules which assign stressability, including the rule which accounts for alternating stressability. Within the diacritic and metrical theories, then, we can motivate the following overall ordering of the rules that we have been considering:

(51) Glide Insertion

E-Mutation

Assignment of stressability

(including alternating stressability)

VHV Assimilation

Vowel Elision

The ordering relationships shown in (51) are consistent with the CV theory of stressability, but they are not fully determined within this model of Passamaquoddy phonology, since we cannot clearly establish the order of VHV Assimilation with respect to V-slot epenthesis rules other than Final Syllable Epenthesis.

#### 8.4.4 Consequences for the formulation of Glide Insertion

We have now seen that Glide Insertion must precede syncope under any of the theories of stressability that we have looked at. In the diacritic and metrical theories, Glide Insertion must also precede Vowel Elision. In these frameworks, then, the input to Glide Insertion must include both VV sequences in which both

vowels are stressable and VV sequences in which the second vowel is unstressable, since no sequences of the latter type will have been eliminated yet. For example, notiy-ahka-n ((3)-out-throw-PEG) 'he throws it out (direction)' and note-hte (out-located-(3)) 'it sticks out' will have the representations shown in (52) prior to the application of Glide Insertion.

- (52) a. C C V C V V C C V C  
 | | | | | | | | | |  
 w n o t e a h k a n
- b. C V C V V C C V C  
 | | | | | | | | | |  
 n o t e a h t e w

Stress cannot yet have been assigned, since stressability has not been assigned. To permit the application of Glide Insertion in (52a) and prevent it in (52b), we will have to require the second vowel in the structural description of the rule to be [+strong], in the diacritic theory, or to bear a lexical accent, in the metrical account. Both approaches seem quite arbitrary. Clearly we would prefer an analysis of glide insertion which did not have to make reference to any sort of arbitrary marks.

The CV theory of stressability permits such an analysis. Although the order of application of Glide Insertion and Vowel Elision is not clearly determined if we adopt this approach, the order in which these rules apply also has no implications for the way they should be formulated. If Glide Insertion applies first, then the representations of nótiy-áhka-n and nóté-hte in the input to Glide Insertion will be as follows.

(53) a. C C V C V V C C V C  
 | / | / | / | / | / | / | /  
 w n o t e a h k a n

b. C V C V C C V C  
 | | | | | | | |  
 n o t e a h t e w

Given the formulation of Glide Insertion proposed in section 1, this rule is applicable in (53a) because this representation contains a sequence of V-slots. The rule is not applicable in (53b), however, because the /a/ of /-ahte-/ 'be located' is a floating vowel. No use of diacritic devices or special marking of particular segments is required in order to make this distinction: unstressable vowels by their nature will not trigger Glide Insertion. We can maintain the simplest possible statement of Glide Insertion regardless of its order with respect to Vowel Elision.

#### 8.4.5 Consequences for stress and syncope

Since Vowel Elision must follow the assignment of stressability in the diacritic and metrical theories, the input to the rules which account for alternating stressability under these proposals must contain sequences of a stressable and an unstressable vowel. For example, the initial schwas of the finals /-əpi-/ 'sit,' /-əs-/ 'cut,' and /-ən-/ 'by hand' will not yet have been deleted when alternating stressability is determined in (54a-c), and the unstressable /i/ of /-ihkəw-/ 'by



body' will still be present at this stage in the derivation of (54d).

- (54) a.  $\acute{a}p\acute{a}t\acute{e}-p\acute{a}-w-\acute{a}k$  (/apate- $\acute{a}$ pi-w- $\acute{a}$ k/)  
 lean-sit-3-33PROX  
 'they (du.) sit leaning against something'
- b. ht- $\acute{t}\acute{a}l$ -ahké-s- $\acute{a}m-\acute{a}n$  (/wt- $\acute{t}\acute{a}l$ -ahke- $\acute{a}s-\acute{a}m-\acute{a}n$ )  
 3-ongoing-land(?)-cut-TI-3IN  
 'he is plowing it'
- c. h-páki-kpé-n- $\acute{a}m-\acute{a}n$  (/w-paki-kpe- $\acute{a}n-\acute{a}m-\acute{a}n$ )  
 3-over-brown.ash-by.hand-TI-3IN  
 'he folds over the vertical splints of it (basket)'
- d. mácé-hk $\acute{a}w$ -a-l (/w-mace-ihk $\acute{a}w$ -a- $\acute{a}l$ /)  
 (3)-start-by.body-DIR-3.OBV  
 'he forces the other to go home by following him;  
 he chases the other away'

If we use "+" and "-" as shorthand for [+strong] and [-strong], the underlying form of (54a) in the diacritic theory may be represented as (55a). (CV structure is irrelevant under this proposal.) I-Mutation replaces the stressable /i/ of /- $\acute{a}pi$ -/ 'sit' with unstressable / $\acute{a}$ /, giving (55b).

- (55) a. +   -   + -   +   +  
           a p  $\acute{a}$  t e  $\acute{a}$  p i w  $\acute{a}$  k
- b. +   -   + -   -   +  
           a p  $\acute{a}$  t e  $\acute{a}$  p  $\acute{a}$  w  $\acute{a}$  k

Alternating stressability is assigned in the diacritic theory by rule (67f) of Chapter 4, repeated here as (56).

(56) [-strong] ---> [+strong] / [-strong] C \_\_\_\_  
 (left-to-right iterative)

The application of this rule to (55b) yields (57): the penultimate / / of the word becomes [+strong].

(57) +   -   + -   +   +  
       a p ə t e ə p ə w ə k

Since the Alternating Stress Rule assigns stress to every other stressable vowel, counting from the end of the word, the output of stress assignment and Vowel Elision in this derivation is \*ápatépówək. This is incorrect. Stress falls on the antepenult in ápatépawək.

The rules of the metrical theory give the same result. The underlying form of ápaté-pə-w-ək in this framework is (58a). I-Mutation replaces accented /i/ with unaccented /ə/ in /-əpi-/, giving (58b).

(58) a. \*           \*       \*   \*  
           a p ə t e ə p i w ə k  
       b. \*           \*           \*  
           a p ə t e ə p ə w ə k

The application of Subfoot Formation to (58b) gives (59a). Foot Formation and the assignment of a word tree derive (59b).

(59) a. |     /     /     |  
 \*     \*     \*     \*  
 a p ə t e ə p ə w ə k

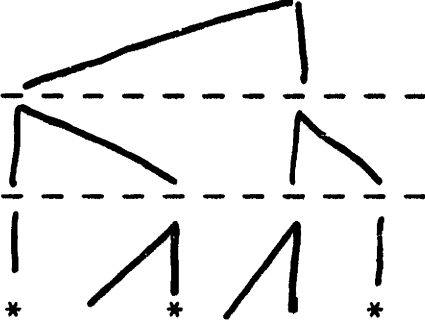
b.  
  
 a p ə t e ə p ə w ə k

Once again stress is incorrectly assigned: (59b) represents \*apətepək, not apətepək.

Both of these derivations fail for the same reason. Both rule (56) and Subfoot Formation look for two unstressable vowels and then make the second one stressable. A procedure of this kind allows the initial /ə/ of /-əpi-/ to participate in the assignment of alternating stressability, even though it follows a vowel. It is easy to see that parallel problems will arise in the derivations of the other items in (54).<sup>11</sup>

In the CV theory, alternating stressability results from the interaction between V-Epenthesis and the basic syllabification rules. Since V-Epenthesis is triggered by unsyllabified consonants, the presence of an unstressable vowel after a vowel is irrelevant to the application of this rule. Thus it makes no difference whether Vowel Elision precedes or follows V-Epenthesis.

Under the assumptions of the CV theory of stressability, the underlying representation of ápaté-pə-w-ək is (60a) and the output of I-Mutation is (60b). Note, however, that there is nothing in (60b) to prevent the syllabification of the /p/ of /-əpə-/ with the /e/ of /apate-/, so the basic syllabification rules will immediately convert (60b) to (60c). Although /e/ and /p/ are separated by /ə/ on the segmental tier, they are adjacent on the CV tier, and this is sufficient for the rules of syllabification.

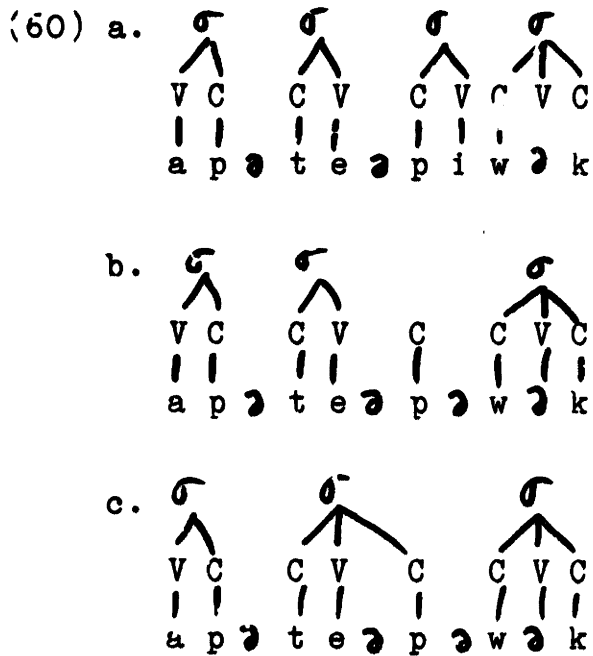

Since no C position is left unsyllabified in (60c), V-Epenthesis is inapplicable, even though the initial /ə/ of /-əpi-/ has not yet been deleted here. We need only assume that Vowel Elision precedes Schwa Support, and the result of applying the stress rules, Vowel Elision, and Schwa Support to (60c) will be (61), an appropriate surface representation for ápaté-pə-w-ək.

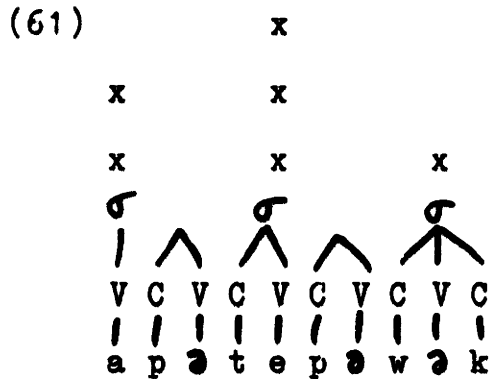

The derivations of (54b-d) proceed along essentially the same lines. In the case of máçé-hkəw-a-l, however, there is one extra twist: both the /h/ and the /k/ of /-ihkəw-/ 'by body' are syllabified with the /e/ of /mace-/ 'start' in the underlying form of this item, across unstressable /i/:

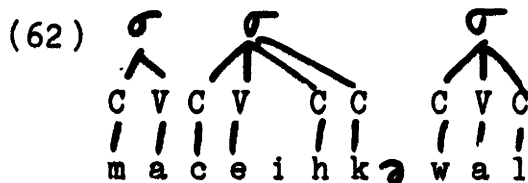

It is the possibility of syllable-final clusters of /h/ and an obstruent which allows both C-slots associated with /hk/ in this representation to be syllabified here, so that V-Epenthesis is again inapplicable.

We see, then, that the stress patterns of words like those in (54) provide strong evidence which favors the CV theory of stressability over the diacritic and metrical alternatives. The facts of stress in these cases follow automatically from our earlier proposals in the CV framework. To obtain the same results within the alternative theories, we would have to stipulate quite arbitrarily that an underlying unstressable vowel

does not participate in the assignment of alternating stressability just in case it follows another vowel.

A small amount of evidence from patterns of syncope appears to confirm the conclusion suggested by data from stress. Both /ə/ and /a/ are syncoating vowels in the final /-əkwahsi-/ 'sleep,' as shown in (63) and (64).

- (63) a. ná-t-kwáhsɔ  
go-sleep-(3)  
'he goes somewhere to sleep'
- b. é-l-kwáhsɪ-t  
thus-sleep-3AN  
'what he dreamed about'
- c. mé-ts-əkwso  
late-sleep-(3)  
'he oversleeps'

- (64) a. təl-kwáhsə-w-ək  
ongoing-sleep-3-33PROX  
'they (du.) are sleeping'
- b. étəl-əkwsɪ-t  
ongoing-sleep-3AN  
'he is sleeping (Conjunct)'

Under the diacritic and metrical theories, we expect the /a/ of /-əkwahsi-/ to be stressable and therefore to be immune to syncope when this final follows a vowel. This is incorrect, as we see in (65).

- (65) a. nó<sup>́</sup>tákwá-kwso  
 ~ nota-kwso  
 not.enough-sleep-(3)  
 'he has not slept enough'
- b. má<sup>́</sup>cé-kwso  
 start-sleep-(3)  
 'he starts sleeping'
- c. má<sup>́</sup>té-kwso  
 be.heard-sleep-(3)  
 'he is heard sleeping; he snores'

Here again the CV theory correctly predicts the facts. For example, má<sup>́</sup>té-kwso has the representation shown in (66) after the application of Final Syllable Epenthesis. Because the /kw/ of /-əkwahsi-/ can be syllabified with the /e/ of /máte-/, V-Epenthesis is inapplicable and the /a/ of the final remains a floating vowel, eventually undergoing Syncope II.

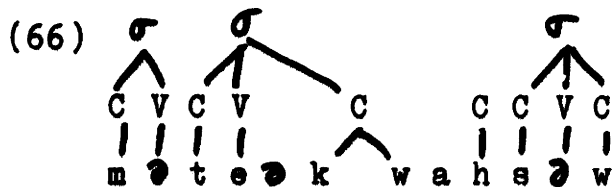

Now this evidence from /-əkwahsi-/ is clouded somewhat by the fact that this morpheme, like so many others in which /a/ has been subject to syncope, has an alternate form as the result of reanalysis. Alongside tá<sup>́</sup>l-kwáhsə, tá<sup>́</sup>l-kwáhsə-w-ə<sup>́</sup>k 'he is sleeping, they (du.) are sleeping,' we also find tá<sup>́</sup>l-əkwso, tá<sup>́</sup>l-əkwso<sup>́</sup>-w-ə<sup>́</sup>k, apparently formed with a final /-əkwsi-/, with invariant /kws/. One might therefore argue that the examples in

(65) are formed by suffixing /-əkwi-/ to vowel-final roots, with loss of /ə/ in the final by Vowel Elision. Against this interpretation, however, is the fact that the initial /ə/ of /-əkwi-/ is inherently stressable. In tál-əkwo, for example, this vowel is stressed even though it is in third position among the schwas in underlying /ətəl-əkwi-w/. Since /y/ is always inserted between stressable vowels within a stem, we would expect surface \*mətíy-əkwo, not máté-kwo, from underlying /máte-əkwi-w/.

No other Passamaquoddy examples have come to my attention which permit a further investigation of the effects of underlying vowel sequences on patterns of syncope. In Woodstock Maliseet, however, it appears that syncope conforms to the predictions of the CV theory of stressability in the final /-əhəm-/ 'swim.' Thus we find máçé-mm-ok (start-swim-(3)-33PROX) 'they (du.) swim away,' reflecting intermediate /mace-hm-ok/, which in turn is derived by Vowel Elision and Schwa Deletion III from underlying /mace-əhəm-w-ək/. As we noted in 5.6.1, the second /ə/ of /-əhəm-/ has been reanalyzed as inherently stressable in Passamaquoddy. This /ə/ is retained, for example, in sákh-əhəm (into.view-swim-(1)) 'when I swam into view' (underlying /sakh-əhəm-a/), even though /ə/ is subject to syncope in a comparable environment in étali wáli pt-à-m (ongoing good hook-TA-AI-(1)) 'where I had been hooking fish well' (in which pt-à-m represents underlying /pət-əh-əm-a/).



1. Irregularly, sequences of identical stressable vowels are sometimes simplified to a single vowel, rather than undergoing Glide Insertion: sénatay-apása-w-ək ~ séht-apása-w-ək (backward-pl.walk-3-33PROX) 'they (pl.) walk backwards,' mótiy-ewéhto ~ mát-ewéhto (be.heard-howl-(3)) 'he (a dog) is heard howling,' the latter with underlying /m tə-/.

We can probably attribute /y/ to the application of Glide Insertion after /i/ in a synchronic analysis of forms like tóhpiy-áhtək (alder-stick) 'alder pole,' based on the noun tóhp 'alder' (< /tóhpi/). Note also wikəwam-i əpəsiy-ahkwí-hkək (house-PN tree-wood-PL-LOC) 'on the wigwam poles' (Mikcic, p. 13), a derivative of əpəs 'tree (an.), stick (in.)' (< /əpəsi/). Historically, however, /y/ in these forms belongs to the noun stems: əpəs is derived from PA \*apanswi-y-i 'lodge-pole' (Goddard 1982:25), tóhp from PA \*wato-xpy-i 'alder' (Siebert 1967:27), both with PA \*-i 3IN. (For the PEA development of PA stems in \*-C(w)iy and \*-Cy, see Goddard (1979a:97-98, 1980:147, 1982:24-25).)

It is possible that /w/ rather than /y/ is the epenthetic glide after /o/. For example, when the particle cō ('then' in 'if... then' constructions, 'yes' when 'no' is expected) is followed by the particles əl (indicating approximation or supposition) and əlo (a contrastive emphatic), the sequence may be pronounced either [ju<sup>v</sup>ally<sup>v</sup>] or [ju<sup>v</sup>wally<sup>v</sup>]. There is also a large class of nouns like skícín 'Indian' for which one might set up stems ending in /w/, /o/, or /əw/. If we postulate a stem for this noun which ends in /o/, then we will presumably want to derive forms like skícínəwək ~ skícínəwək 'Indians' via insertion of /w/ after /o/. The apparent variation in the accentuation of such forms makes it difficult to decide on an analysis.

2. Like I-Mutation, the change of /a/ to /e/ is triggered by the derivational affix /-w-/ as well as by third person /-w/: ksínohká-wi-nákwsə ~ ksínohké-wi-nákwsə (sick-DA-look-(3)) 'he looks sick.'

3. Apparently the only II stems in /a/ are those formed with /-ha-/ ~ /-ya-/ 'go,' in which /a/ is always changed to /e/ in Independent forms. Both these stems and those with basic /e/ add /t/ in positive forms before the suffix /-w/ when it is not final in the word. The /w/ of the suffix contracts with a following /ə/ to /o/. Before other vowels it is deleted. Thus with /píhci-ya-/ 'go far' we have píhci-ye 'it goes far,' but píhci-ye-t-ol 'they (in.) go far,' píhci-ye-t-ə 'it (abs.) went far.' With /əte-/ 'be located' we have əte 'it is there,' but əte-t-ol 'they (in.) are there,' əte-t-ə 'it (abs.) was there.' Glide Insertion is applicable in II verbs only in certain negative forms: má te əté-wi-yil 'they (in.) are not there,' má te əté-wi-ye 'it (abs.) is not there anymore.' Sherwood (1983b:216) gives Maliseet əte-w-e 'it (abs.) was there,' without /t/ and with retention of /-w-/ after stem-final /e/, but this form is rejected by my Passamaquoddy consultants.

4. There is some evidence of a former distinction between stems ending in /i/ and stems ending in /iy/. For example, the

noun man 'money' (stem /mani-/) has a synchronically irregular locative form máni-hik, as if derived from underlying /maniy-k/, with epenthetic /ə/ inserted before the locative suffix /-k/.

5. Also wəsəkiy-atəp; cf. wəsəkiy-atp-əl ~ wəsəkiy-atpí-yil ~ wəsəkiy-atəpí-yil 'skulls.'

6. It is not clear whether variation in the shape of -ayya- is due to differences in underlying forms or differences in rule systems. It appears that alternants with h for the first y in -ayya- are used by the same speakers who have h for y in the sequence iyi (see 3.4). Moreover, it seems likely that -ayya- should be analyzed, at least historically, as a combination of a medial /-ay-/ or /-ah-/ and the final /-ya-/ 'go,' presumably one made with connective /i/.

7. I have also recorded irregular (?) təláhik 'they (du.) are playing,' as if from /ətəl-aha-w-ək/.

8. Another possibility would be to generalize Schwa Deletion III so that will delete unstressable /i/ between /h/ and /y/.

9. It might be argued that iy should be derived from /y/ where it is replaced by ey in Initial Change. I will argue in Chapter 9, however, that Initial Change is not a unified process and that the /i/ is directly replaced by /e/ in Changed forms.

10. Note that this ordering must hold in the metrical framework even if we choose to complicate the statement of VHV Assimilation so that this rule may precede syncope between /h/ and /m/. In the metrical theory, it is Subfoot Formation which accounts for the fact that the last /ə/ of íkətəhəm is stressable. But this /ə/ must be stressable in order to trigger assimilation, so assimilation must follow Subfoot Formation. Since Subfoot Formation is also the mechanism of alternating stressability in the metrical theory, it follows that VHV Assimilation must follow the assignment of alternating stressability.

11. Actually, rule (56), alternating stressability in the diacritic framework, is not applicable to the underlying representation of (54d), máçé-hkəw-a-l, since this rule permits only a single C between the [-strong] vowels in the environment which triggers it. Thus the diacritic theory, as it stands, makes the same prediction as the CV theory with respect to the stress pattern of this form. But (56) must be modified to permit /hC/ as well as a single C in the triggering environment in order to account for the stress of forms like nát-ków-a-l 'he goes right to the other,' underlying /w-nat-ihkəw-a-l/ (3-go-by.body-DIR-3.OBV). Once this modification is made, the diacritic theory, like the metrical theory, will incorrectly predict \*máçé-hkəw-a-l in place of máçé-hkəw-a-l.

## Chapter 9

### Initial Change

Three modes of the Conjunct Order are characterized by Initial Change. Change is not always overtly expressed, but it is frequently realized as a modification of the first vowel in the basic form of the initial morpheme of the verb complex. For this reason, Changed forms often provide evidence which bears on the choice of phonological underlying forms for morphemes which may occur in this initial position. Some morphemes have irregular Changed forms, however, so that evidence from Change cannot always be regarded as conclusive.

It does not appear to be possible to state the vowel mutations in Changed forms in a single synchronic rule, but three patterns of considerable generality can be identified. It is not clear, however, that these patterns correspond to phonological rules. It may, in fact, be more appropriate to view the relationship between Changed and Unchanged stems as one of non-phonological allomorphy. The recurrent patterns of mutation might then be stated as redundancy rules relating Changed and Unchanged stems which are represented with distinct underlying forms.

The Conjunct modes which are characterized by Initial Change are the Participle and the so-called Changed Indicative and

Changed Subjunctive modes. The sentences in (1) give parallel examples of Changed forms of these types which are drawn from the paradigm of the AI verb /əlohk-e-/ 'work, do.' Change is expressed in these examples by the shift of stem-initial /ə/ to /e/. The corresponding Unchanged Subjunctive form of /əlohk-e-/ is lohk-e-t (work-AI-3AN-(SUBJ)) 'if he works,' in which this /ə/ is deleted by Schwa Deletion V.

(1) a. nékəm əc élohk-e-t.

he FUT work-AI-3AN

'He is the one who will work.'

b. nékè élohk-e-t, wəl-ápesó-hpən.

then(past) work-AI-3AN good-paid-(3)-PRET

'When he was working, he was well paid.'

c. nékè élohk-e-t, éci síkté-hsəni-t.

then(past) work-AI-3AN-(PERF) very to.death-tired-3AN

'When he worked, he was very tired.'

As I noted in Chapter 2, the distinction between the Changed Indicative and the Changed Subjunctive in Maliseet-Passamaquoddy appears to be one of aspect rather than mode: Indicative forms are imperfective, while Subjunctive forms are perfective. I therefore reserve the term "subjunctive" for the Unchanged Subjunctive mode, which is typically used in clauses indicating hypothetical or contrary to fact conditions. Changed forms other than participles will be described as imperfective or perfective, rather than in terms of mode.

The reader should also bear in mind that the perfective and subjunctive suffixes of the Conjoint paradigms consist only of an

abstract vowel (an underlying empty V-slot in the analysis of Chapter 10). Since they are always final in the word, these suffixes never appear in surface forms. Their underlying presence is revealed only through their phonological effects, notably the fact that subjunctive forms are always pronounced with the accentual patterns characteristic of words which have undergone Final Vowel Deletion.

From a syntactic point of view, the distribution of Initial Change resembles that of the personal prefixes of the Independent Order, since Change, when it is overt, is a modification of the first word of the verb complex, not necessarily of the verb word itself. In the examples in (1), Change is realized by replacing the /ə/ of the root /əlohk-/ 'work, do' with /e/. In (2a), the stem /əlohk-e-/ is used as a complex final mand suffixed to the root /əl-/ 'thus.' Here it is the /ə/ of /əl-/ which is replaced by /e/: cf. əl-lóhk-e (thus-work-AI-(3)) 'he does thus.' In (2b) and (2c), Change is realized by the shift of /ə/ to /e/ in the preverbs /kəti/ 'future' and /əli/ 'thus,' the latter based on the root /əl-/. Note that the verb complex is interrupted by the subject of the clause in (2c).

(2) a. nékəm nít əl-lóhk-e-t.

he that thus-work-AI-3AN

'He is the one who did that.'

b. kəti əl-lohk-é-li-t

future thus-work-AI-OBV-3AN

'what the other was going to do'

c. éli n-kwáss káti sákáma-wi-t

thus 1-son future chief-AI-3AN

'that my son was going to be tribal governor'

The fact that the distribution of Initial Change must be stated in terms of a phrasal category raises interesting questions about the relationship between morphology and syntax, especially in view of the fact that some morphemes have idiosyncratic Changed forms. Our primary concern in the present context, however, is the phonological expression of Initial Change.

In section 1, the shift of /ə/ to /e/ in Changed forms is discussed, together with a class of cases in which this replacement is not made. Section 2 is concerned with cases in which /i/ and /a/ become /e/ in Changed forms. As we will see, underlyingly unstressable /i/ and /a/ are subject to this modification, while inherently stressable /i/ and /a/ are generally stable. Mutation in iy and ow is taken up in section 3, while irregular Changed forms are discussed in section 4. The conclusions of this chapter are summarized in section 5.

### 9.1 Effects on /ə/

By far the most common reflection of Initial Change is the replacement of /ə/ by /e/. The /ə/ in question may be inherently stressable or underlyingly unstressable. If it is unstressable, it may participate regularly in syncope or it may be an exception to one or more of the syncope rules. These possibilities are illustrated in (3)-(6). The /ə/ of /tək-/ 'hit' is inherently

stressable, while that of /pəm-/ 'along' is unstressable in the basic form of this morpheme. The /ə/ of /kəs-/ 'intense' undergoes Syncope I regularly in (5b), while the /ə/ of /əpi-/ 'sit' is a consistent exception to both Syncope I and Schwa Deletion V. In all of these roots, /ə/ becomes /e/ in Initial Change.

- (3) a. tək-əm-a-t  
 hit-TA-DIR-3AN-(SUBJ)  
 'if he hits the other'
- b. tək-əm-òk  
 hit-TA-1/3(3)-(PERF)  
 'when I hit him/them'
- (4) a. pəmí-cəwən  
 along-flow-(3)  
 'there is a current'
- b. pəmí-cəwə-k  
 along-flow-3IN  
 'where there is a current'
- (5) a. h-kəs-éhl-a-l  
 3-intense-TA-DIR-3AN-3.OBV  
 'he hurts the other' Group<
- b. ks-éhl-a-t  
 intense-TA-DIR-3AN-(SUBJ)  
 'if he hurts the other'

c. kés-ehl-à-t  
 intense-TA-DIR-3AN-(PERF)  
 'when he hurt the other'

(6) a. əpì-n  
 sit-2  
 'sit (sg.)!'

b. épi-t  
 sit-3AN  
 'when he sits'

All occurrences of /ə/ which are replaced by /e/ in Changed forms either begin a word or follow a single non-syllabic. Although some verb stems with underlying initial clusters have arisen through reanalysis, Change has not been generalized to /ə/ which follows such clusters. For example, the reanalysis of /asp-əpi-/ 'sit up high' as /sp-əpi-/ has led to the use of forms like n-sp-əp (1-above-sit) 'I sit up high,' but speakers who use n-sp-əp have sp-əpi-t, not \*sp-épi-t, in place of ésp-əpi-t (above-sit-3AN-(PERF)) 'when he sat up high.' Similarly, we find kəkwəpəhsà-k but not \*kəkwəpəhsà-k 'when it rained and snowed at the same time,' a Changed perfective form corresponding to kəkwəpəhsan 'it rains and snows at the same time.' (The perfective form késkwəpəhsà-k, representing an underlying stem /kəskwəpəhsan-/ without reanalysis, also continues in use.)

Given the syntactic distribution of Initial Change, we might propose that Changed forms contain an abstract prefix, perhaps one consisting only of the morphological feature [+Change]. We



might then propose a rule like (7) to account for the effects of Initial Change in the examples cited above.

(7) Initial Change I

$$\begin{array}{ccc}
 \text{(V)} & & \text{V} \\
 \text{ɪ} & \longrightarrow & \text{ɪ} / [+Change] + \begin{pmatrix} \text{C} \\ \text{ɪ} \\ \text{X} \end{pmatrix} \underline{\hspace{1cm}} \\
 \text{ə} & & \text{e}
 \end{array}$$

The effect of this rule is to replace any /ə/, stressable or unstressable, with a stressable /e/, provided that it follows at most one non-syllabic segment at the beginning of the verb complex in a Changed mode.

For the most part, the phonological modification represented by (7) is carried out obligatorily whenever it is applicable. In certain cases, however, this transformation is optional or is blocked altogether. Virtually all of these exceptions involve verbal initials which are derived from noun stems. For example, the change of /ə/ to /e/ is optional in (8) and (9), verb forms based on the nouns mátewékan 'flag' and pásənòt 'basket.' (The stem of the latter is /əpəsənote-/; cf. ht-əpəsənòt 'his basket,' pásənóte-k 'basket (loc.).' All of these examples are Changed forms: (8a) is a participle, while (8b) and (9) are Changed perfective forms.

- (8) a. pá<sup>́</sup>sən<sup>́</sup>oté-hke-t  
basket-acquire-3AN  
'he who makes baskets'
- b. é<sup>́</sup>pəsən<sup>́</sup>óte-hkè-t  
basket-acquire-3AN-(PERF)  
'when he made baskets'
- (9) a. m<sup>́</sup>etewé<sup>́</sup>kən-ah-ási-k  
~ m<sup>́</sup>etewé<sup>́</sup>kən-ah-ási-k  
flag-TA-II-3IN-(PERF)  
'when it had a flag on it'

The optional expression of Change in verbs derived from body-part nouns (section 5.4) is probably a related phenomenon.

The shift of /ə/ to /e/ is blocked altogether in (10) and (11), where /-ohke-/ 'acquire' is suffixed to noun stems referring to species of animals, deriving verbs of hunting. The nouns on which these verb forms are based are ətóhk 'deer' and m<sup>́</sup>əciyèhs 'partridge.'

- (10) a. ətók-k-ahtí-c-ik  
deer-acquire-PL-3AN-33PROX  
'deer hunters (pl.)' ("they (pl.) who hunt deer")
- b. \*etok-k-ahti-c-ik
- (11) a. m<sup>́</sup>əciyéhso-hkè-t  
partridge-acquire-3AN-(PERF)  
'when he hunted partridges'
- b. \*meciye<sup>́</sup>hso-hke-t

Not all denominal verbs show this kind of blocking effect, however. Vowel mutation proceeds regularly, for example, in the stem /əwas-is-əwi-/ AI 'be young,' a derivative of wás-is (child-DIM) 'child' (stem /əwas-is/; cf. ht-ówas-ís-əm-əl (3-child-DIM-POSS-3.OBV) 'his child').

- (12) a. wás-is-əwi-w  
 child-DIM-AI-3  
 'he is young'  
 b. éwás-is-əwi-t  
 child-DIM-AI-3AN-(PERF)  
 'when he was young'

In an interesting discussion of this phenomenon, Leavitt (1985:86-88) suggests that the expression of Initial Change is blocked in denominal verbs when "the meaning of the verb focuses on the noun." He notes, for example, that /ə/ may not be replaced by /e/ in metekəni-nakw-ah-k (skin-look-II-3IN) 'that which looks like skin, leather' or pəm-awso-wi-əwi-hpi-t (along-live-NOM-eat-3AN) 'he who eats people, cannibal,' forms in which the nominal meaning of the stem is particularly salient. (The basic nouns here are matékən 'skin' and pəm-áwso-wi (along-live-NOM) 'person.')

The second of these examples seems particularly significant, since the root /pəm-/ 'along' has the regular Changed form /pem-/ where it does not form part of a denominal initial: pem-awsit (along-live-3AN-(PERF)) 'when he was alive.' (Compare also (4b).)

Even more striking is a contrast that Leavitt reports in the way that initials based on body-part nouns are treated in two

types of verbs. In formations with the final /-ne-/ 'ache, suffer,' the replacement of /ə/ by /e/ is permitted in Changed forms (although it is optional, as we saw in 5.4). Leavitt gives the following examples.<sup>1</sup> (Compare w-ə́niyákə n (3-head) 'his head,' psóhon 'heart,' mə́shon ((3)-heart) 'his heart.')

- (13) a. w-ə́niyákəní-ne  
 3-head-ache-(3)  
 'he has a headache'  
 b. w-é́niyákəní-ne-t  
 3-head-ache-3AN  
 'when he has a headache'

- (14) a. psóhoní-ne  
 heart-ache-(3)  
 'he has heart trouble'  
 b. méshoní-ne-t  
 heart-ache-3AN  
 'when he has heart trouble'

When the same initials are used with /-nakw-ət-/ 'look like,' however, the change of /ə/ to /e/ is blocked: e may not replace ə in the first syllable of (15b), not is initial mes permitted in (16b).

- (15) a. w-<sup>á</sup>niyáka<sup>ni</sup>-nákw-<sup>ə</sup>t  
 3-head-look-II-(3)  
 'it looks like a head'
- b. w-<sup>á</sup>niyáka<sup>ni</sup>-nákw-ah-k  
 3-head-look-II-3IN  
 'that which looks like a head'
- (16) a. psóhó<sup>ni</sup>-nákw-<sup>ə</sup>t  
 heart-look-II-(3)  
 'it looks like a heart'
- b. psóhó<sup>ni</sup>-nákw-ah-k  
 heart-look-II-3IN  
 'that which looks like a heart'

These constraints on the expression of Change in denominal verbs are something of a puzzle on the assumption that the vowel mutations that we find in Changed forms are phonological in character. The process represented by (7) does not apply consistently to all Changed forms. One and the same morpheme may appear with or without overt Change according to the morphological structure of a given stem. In fact, stems with essentially the same structure may receive different treatment in Initial Change. The applicability of (7) appears in some cases to be a property of the stem as a whole (perhaps one with a semantic basis), rather than a locally determined property of phonological representations.<sup>2</sup>

## 9.2 The role of stressability

For the most part, vowels other than /ə/ remain unmodified in Changed forms. There are two systematic classes of exceptions to this generalization, however. First, certain occurrences of /i/ and /o/ before /y/ and /w/ become /e/ in Initial Change. Cases of this type will be discussed in the following section. More interesting is the fact that occurrences of /i/ and /a/ which are subject to syncope are also replaced by /e/. (There are no examples in which syncope occurs in a position where it could be affected by Change.)

Examples of invariant /i/, /a/, /o/, and /e/ are given in (17)-(21). I have chosen examples in which these segments precede /hC/ and /sC/ in order to bring out the contrast with syncope, but non-mutating vowels are not restricted to these contexts.

- (17) a. wíhkwi-ye  
take-go-(3)  
'he faints'
- b. wíhkwi-ya-t  
take-go-3AN-(PERF)  
'when he fainted'

- (18) a. áhtəli íkətəhəm  
 keep.on yawn  
 'he keeps on yawning'
- b. áhtəli míl-í-hti-t  
 keep.on give-1.OBJ-33PROX-3AN  
 'they keep on giving it to me (Conjunct)'
- (19) a. páskwe  
 noon-(3)  
 'it is noon'
- b. páskwe-k  
 noon-3AN  
 'when it is noon'
- (20) a. tóhki-ye  
 awake-go-(3)  
 'he is awake'
- b. tóhki-yà-y  
 awake-go-1  
 'when I wake up'
- (21) a. méhčí-kətən  
 finish-year-(3)  
 'the year ends'
- b. méhčí-kətə-k  
 finish-year-3IN  
 'when the year ends'

Examples showing the change of syncopating /i/ and /a/ to /e/ are given in (22)-(30). For syncope in the roots shown here, the reader is referred to 6.1. and 6.2, examples (4)-(8), (30), (32), (33), and (41).

- (22) a. h-kíht~~o~~m-át-~~o~~m-~~o~~n  
 3-disinclined-TI-TI-3IN  
 'he does not feel like doing it'
- b. kéht m-at-~~o~~-k  
 disinclined-TI-TI-3AN-(PERF)  
 'when he did not feel like doing it'
- (23) a. n-míhkw-èy  
 1-red-AI  
 'I am red'
- b. méhkw-éyi-t  
 red-AI-3AN  
 'he who is red'
- (24) a. níhtak  
 (1)-mourn-(AI)  
 'I am in mourning'
- b. néhtak-ì-t  
 mourn-AI-3AN  
 'he who is in mourning'



- (25) a. níhtàw  
 (1)-know.how-(talk)  
 'I know how to talk'
- b. néhtaw-è-t  
 know.how-talk-3AN-(PERF)  
 'when he knew how to talk'
- (26) a. níhtop-h-óko-n  
 (1)-catch-TA-INV-SUBORD  
 'he catches me (Subordinative)'
- b. néhtop-h-à-t  
 catch-TA-DIR-3AN-(PERF)  
 'when he caught the other'
- (27) a. h-táhk-áhsəmi-nè  
 3-cool-swim-SUBORD-(ASPECT)  
 'he would have swum (to cool off)'
- b. téhk-ahsəmi-t  
 cool-swim-3AN-(PERF)  
 'when he swam (to cool off)'
- (28) a. n-táhk-w-ən-ahkè-p n  
 1-arrest-by.hand-AI-11  
 'we (du. exc.) arrest'
- b. téhk-w-ən-ahkè-t  
 arrest-by.hand-AI-3AN-(PERF)  
 'when he arrested'

- (29) a. ht-áhsihpíl-a-l  
 3-give.medicine-DIR-3AN-(PERF)  
 'he gives the other medicine'
- b. éhsíhpil-à-t  
 give.medicine-DIR-3AN-(PERF)  
 'when he gave the other medicine'
- (30) a. nt-ásp-ə̀p  
 1-above-sit  
 'I sit up high'
- b. ésp-ə̀pì  
 above-sit-(1)  
 'when I sit up high'

The correlation between syncope and Change holds up even in cases in which each of these phenomena shows variation. So, for example, speakers who allow táhk-w-ən-ahkè-t in place of tkw-ən-kè-t (arrest-by.hand-AI-3AN-(SUBJ)) 'if he arrests' also allow táhk-w-ən-ahkè-t in place of téhk-w-ən-ahkè-t (arrest-by.hand-AI-3AN-(PERF)) 'when he arrested.' Speakers for whom téhk-ahsə̀mì-t may replace tk-ahs mi-t (cool-swim-3AN-(SUBJ)) 'if he swims' also have táhk-ahsə̀mì-t for téhk-ahsə̀mì-t (cool-swim-3AN-(PERF)) 'when he swam.'

We see, then, that two facts about the effects of Change on /i/ and /a/ require explanation. What distinguishes the occurrences of /i/ and /a/ which undergo mutation from those which do not? Why does the overt expression of Initial Change correlate so closely with syncope in these cases?

Both facts are easily accounted for, given the CV theory of stressability. The occurrences of /i/ and /a/ which undergo syncope are those which are underlying floating vowels. If the rule which replaces /i/ and /a/ with /e/ in Changed forms is also restricted to floating vowels, it will pick out just the right class of cases. The rule might be stated formally as shown in (31).

(31) Initial Change II

$$\textcircled{v} \text{ ---} \rightarrow \begin{array}{c} \text{V} \\ | \\ \text{e} \end{array} / [+Change] + \left( \begin{array}{c} \text{C} \\ | \\ \text{X} \end{array} \right) \text{ ---}$$

When syncoating /a/ is reanalyzed as non-syncoating /a/, it is provided with a V-slot in underlying representations. The result is that (31) is no longer applicable. This accounts for the fact that the correlation between syncope and Change holds in such detail.

Now the domain of (31), as it is stated, overlaps with that of (7): both rules predict that unstressable /ə/ will be replaced by /e/ in Changed forms. To eliminate this redundancy, we might restrict (7) so that it applies only to inherently stressable /ə/, although this move would leave us without any formal statement of the generalization that Initial Change affects stressable and unstressable /ə/ in the same way. In any case, under either account it appears that the expression of Initial Change in the examples that we have looked at so far is governed by two similar, but distinct, generalizations.

Consider, finally, how we might describe the effects of Initial Change on /i/ and /a/ under a diacritic or metrical theory of the stressable/unstressable distinction. In a diacritic account, we would have to restrict overt Change to [-strong] occurrences of /i/ and /a/, postulating yet another rule which is sensitive to the value of this arbitrary feature. In a metrical account, we would need to formulate the rule so that it applies only to unaccented /i/ and /a/. We cannot simply restrict overt Change to unstressed /i/ and /a/: since it is the output of Initial Change which determines the distribution of stressable and unstressable vowels in a word, the output of Change must be the input to Subfoot Formation. Thus the phonetic plausibility of a metrical account of syncope, in which deletion may be restricted to unstressed vowels, does not carry over to the analysis of Initial Change. Here we must directly refer to the absence of a lexical accent.

### 9.3 Change in iy and ow

Surface i before y and o before w are replaced by e in Changed forms in a number of initials. This treatment is not universal, however: i and o remain unmodified, for example, in the stems shown in (33) and (34). (I do not know whether these stems are analyzable.)

- (33) a. míyawcéko  
           'he (a child) is pretty'  
       b. míyawcéki-t  
           'he who is pretty'  
       c. \*meyawceki-t

- (34) a. mówikáso  
           'he has a swollen gland'  
       b. mówikási-t  
           'he who has a swollen gland'  
       c. \*mewikasi-t

In 5.9 we noted several roots in which initial o alternates with both zero and e after the pattern illustrated in (35).

- (35) a. ht-ówéhka-n  
           3-use-3IN  
           'he uses it'  
       b. wéhké-n  
           use-2  
           'use (sg.) it!'  
       c. éwéhke-t  
           use-3AN  
           'when he uses it'

In cases of this kind, it seems reasonable to attribute surface o to underlying /ə/, since this move allows us to bring the alternations in question into line with those which are characteristic of underlyingly unstressable /ə/ before /l/. This analysis is confirmed, for the stem /əwehke-/ 'use,' by forms

like h-kís-awéhka-n (3-past-use-3IN) 'he used it' in which the hypothesized /ə/ is directly attested.<sup>3</sup> Apparently, then, some Changed forms in which e replaces o before w simply reflect the usual effect of Change on basic /ə/.

In some cases, however, it appears that surface ow has been reanalyzed as underlying ow even though Changed forms with e have continued in use. For example, the stem kowi- 'sleep' has Changed forms with e as shown in (36). But the o of kowi- is consistently [u] in all positions rather than varying with [ə], suggesting that it is a stressable vowel: hence the transcription of (36a) with an accented initial syllable.

- (36) a. kówi-n (\*kəwi-n)  
 sleep-2  
 'go (sg.) to sleep!'
- b. kéwi-t  
 sleep-3AN-(PERF)  
 'when he fell asleep'

Now the o of kowi- does not appear to undergo penultimate lengthening, as we might expect it to in an example like (36a). As we saw in 3.3, this behavior is typical of o in structures derived by assimilation, including ow which represents underlying /oh/, but it is not typical of o in ow from underlying /ow/. It is therefore interesting to note that various third person Independent Indicative forms of 'sleep' are based on a stem with the surface shape koho- as if derived by I-Mutation from underlying /kohi-/:

(37) a. kóho

sleep-(3)

'he sleeps'

b. kóho-kk

sleep-(3)-33AN.ABS

'they (du.) have fallen asleep'

In fact it appears to be possible to derive all of the Unchanged forms of 'sleep' from /kohi-/, if the rule of 3.3.3 which changes /oh/ to /ow/ can be restricted here so that it applies only before non-round vowels. But if kowi- reflects underlying /kohi-/, then the relationship between the surface stems kowi- and kewi- cannot be mediated by any otherwise attested rule of Initial Change.

We noted above that underlying /ə/ is consistently replaced by /e/ in the initial syllables of Changed forms, except in denominal verbs. On the other hand, if some occurrences of ow in initial syllables have been reanalyzed as underlying /ow/, then we might expect to find variation in Changed forms in which ow becomes ew, since underlying /o/ is typically invariant. In the case of 'sleep,' Changed forms based on kowi- rather than kewi- are generally rejected, but in other cases there does appear to have been some extension of Unchanged stems into Changed paradigms. I have recorded both cówáhpí-ya-t and céwáhpí-ya-t (into.water-go-3AN-(PERF)) 'when he fell into the water' as Changed perfective forms corresponding to cówáhpí-ye (into.water-go-(3)) 'he falls into the water.' Although forms like péw-ál-ok (want-TA-1/3(3)) 'the one (an.) that I want' have ew for the ow

of h-pów-ál-a-l (3-want-TA-DIR-3.OBV) 'he wants the other,' I have also heard (38) with pow-.

- (38) kèkw pów-ál-kittiy-át-ə-k nət?  
what want-INTENSIVE-TI-TI-3AN that(an.)  
'What the hell does he want?'

Since the verb in a question of this type is a participle, we would expect pew- for underlying /pəw-/ in this sentence.

It seems likely that i reflects earlier \*ə (or short \*a) where iy becomes ey in Changed forms, but there appears to be no evidence apart from that of Change itself to suggest that /əy/ underlies iy in such cases in the contemporary language. As we noted in 8.3.2, there are no alternations between surface ə and i which require us to postulate a rule changing /ə/ to /i/ before /y/. It therefore seems best to suppose that /i/ is directly replaced by /e/ before /y/ in Changed forms.

Examples of these iy ~ ey alternations are given in (39)-(41). We expect the i of miyaw- 'exact' to be stressable in (39a), since this is a prefixed form. It is not clear to me whether i is stressable or unstressable in (40a) and (41a). I have transcribed these words with accented i because I have not encountered the kind of phonetic reduction here which is characteristic of ə in unstressed initial syllables and of unstressable i in forms like élohki-yàn (work-1-(PERF)) 'when I worked.'



- (39) a. míyaw-té-ləw-a-l  
 (3)-exact-strike-shoot-DIR-3.OBV  
 'he shoots the other accurately'
- b. méyáw-te-ləw-à-t  
 exact-strike-shoot-DIR-3AN-(PERF)  
 'when he shot the other accurately'
- (40) a. píyémi-tp-áso  
 more-powerful-AI-(3)  
 'he is the most powerful'
- b. péyémi-tp-əsi-t  
 more-powerful-AI-3AN  
 'he who is the most powerful'
- (41) a. píyakwtíhikəní-hke  
 wood.chip-AI-(3)  
 'he gathers wood chips'
- b. péyakwtíhikəní-hke-t  
 wood.chip-AI-(3)  
 'when he gathers wood chips'

Since surface ə does not occur before y, and since there are no roots which begin with iy and also occur in complex finals, we do not have the kind of evidence for underlying /əy/ as the source of stem-initial iy that h-kís-əwéhka-n 'he used it' provides for /əw/ as the source of ow in ht-ówéhka-n 'he uses it.' There are a few roots which drop initial i before y in unprefixed forms, but we do not find e for this i in the corresponding Changed forms. For example, -iyal- 'around'

appears as such after the personal prefixes but surfaces as yal- word-initially in Changed forms as well as in Unchanged forms.

In a few stems, ey in Changed forms corresponds to ih or to ih alternating with iy in Unchanged forms, as shown in (42)-(44).

(42) a. íyo

be.located-(3)

'he, it is there'

b. éyi-t

be.located-3AN-(PERF)

'when he was there'

c. nékam ñit            ht-íhi-nè-ss?

he      that(in.) 3-be.located-SUBORD-DUBIT

'Was he there?'

(43) a. ht-íy-oltí-ni-ya

3-have-PL-3IN-33PROX

'they (pl.) have it'

b. éyi-t

have-3AN-(PERF)

'when he had it'

c. nékam ñit            ht-íhi-nè-ss?

he      that(in.) 3-have-3IN-DUBIT

'Did he have it?'

- (44) a. íh-m-ow-ì-t  
 have-TI-TA-1.OBJ-3AN-(SUBJ)  
 'if he has mine'
- b. éy-m-ow-ì-t  
 have-TI-TA-1.OBJ-3AN-(PERF)  
 'when he had mine'

These alternations of ih and iy with ey cannot be reduced to any of the regular phonological patterns of the language. The forms with h in (42)-(44) are used by all speakers, not just those who replace y with h in iyi as discussed in 3.4; and in any case it seems likely that hm represents /həm/ in (44a) (cf. the discussion of the sources of hm in 5.6.1), so that the usual patterns of variation between h and y would not be relevant to this example. We saw in 3.3.3 that no general rule can be formulated for Passamaquoddy which would derive iy from /ih/ as ow is derived from /oh/. We might, of course, propose a morphologically governed rule of this type for the cases at hand, but such an analysis would require us to set up underlying initial /i/ in ihí- 'be located, have' and ih-m-ow- 'have X of Y's,' so that a regular treatment of Change in these stems would still be impossible.

In the end, there appears to be no real support for an analysis which would derive iy from /əy/ where it alternates with ey. We saw above that some occurrences of ow which become ew in Changed forms resist analysis as underlying /əw/. Since we seem to be dealing with inherently stressable i and o here, it appears that these cases of vowel mutation in Changed forms fall under

neither of the rules for the expression of Initial Change which we have formulated above. On the other hand, the effects of Initial Change on iy and ow can be stated directly in a reasonably simple rule:

(45) Initial Change III

$$\left[ \begin{array}{c} +\text{high} \\ \alpha\text{round} \end{array} \right] \dashrightarrow e / [+Change] + \begin{array}{c} \text{C} \\ \left( \begin{array}{c} \text{V} \\ | \\ \text{X} \end{array} \right) \end{array} \begin{array}{c} \text{C} \\ | \\ \text{C} \end{array} \left[ \begin{array}{c} +\text{high} \\ \alpha\text{round} \end{array} \right]$$

This rule will change stressable /i/ or /o/ to /e/ before /y/ or /w/, respectively, assuming here as in earlier chapters that /o/ is phonologically a high vowel. As we noted at the beginning of this section, however, (45) cannot represent a general phonological rule, since i and o do not alternate with e before y and w in all roots.

#### 9.4 Irregular Changed forms

Several morphemes have irregular Changed forms or Changed forms which do not match their prefixed forms. For example, the root /tot-/ 'by, past, to an extreme' has the Changed form /etot-/, suggesting basic /ətot-/, but no initial /ə/ surfaces after a prefix:

(46) a. tócf-ye

extreme-go-(3)

'he, it goes past, goes fast'

b. n-tóci

1-extreme-(go)

'I go past, go fast'

c. étoci'-ya-t

extreme-go-3AN

'he is going past, going fast (Conjunct)'

The verb kihke (plant-(3)) 'he plants' has Changed forms which are based on a stem /ekihke-/, but its prefixed forms show variation between the stems /-əkihke-/ and /-ahkihke-/:

(47) a. ékihke-t

plant-3AN

'when he plants'

b. ht-əkihka-n

3-plant-PEG

'he plants it'

c. nt-ahkih

1-plant

'I plant'

As we noted in 6.2, the different stems of this verb reflect the historical developments of initial /ah/ where /a/ is subject to syncope. The same observation applies to the verb əté (located-(3)) 'it is there,' which has synchronically irregular Changed forms like éhte-k (located-3IN) 'where it is' that reflect the historical connection between /əte-/ and the final /-ahte-/ 'be located.'

Stems which historically begin with /wə/ frequently have Changed forms with e for expected w. One consultant (S.G.) gives nílòn nòskicinowìpàn 'we (du. exc.) are Indians,' suggesting a stem /wəskicinowi-/, but nílòn éskicinówiyek 'we (du. exc.) who are Indians,' which appears to require /əskicinowi-/. Another (P.D.), who gave nòskwihìk as the first person form of skwihìke 'he dips his bread in molasses,' first gave wéskwihìket 'one who dips his bread in molasses,' then rejected this form in favor of éskwihìket. Other types of variation in the Changed forms of verbs in sC- were discussed in 6.2.

Finally, I should point out that a few morphemes occur only in constructions which require Changed forms. The preverb eci 'extremely, very, at that point, when' represents an irregular contraction of etoci (root etot-, Changed form of tot-) and continues to be used only where Change is appropriate: éci péci-ya-y (when arrive-go-1) 'when I arrive.' The preverb ehtahs ~ ehtahsi 'each, every' (ehtas before the emphatic enclitic te) is not related to any other stem, but is also restricted to Changed forms, as is the root mehs- '(what) for, why,' which occurs most frequently in the preverb mehsi:

- (48) a. éhtáhsi kísk-áh-k-il  
           every day-II-3IN-33IN  
           'every day'
- b. éhtás te lí-kətək  
           every EMPH thus-year-3IN  
           'every season'

- (49) a. kékwsèy àpc méhsí-hpi-hin?  
 what again why-eat-2  
 'Why are you (sg.) eating again?'
- b. kékwsèy méhsi mátiy-éwestów-ən?  
 what why be.heard-speak-2  
 'Why are you (sg.) talking?'

### 9.5 Conclusion

Although no general statement is possible, we have seen that overt expression of Initial Change in Passamaquoddy usually conforms to one of three patterns, for which we have formulated the following rules.

#### (50) Initial Change

$$\text{I. (V)} \quad \begin{array}{c} \text{V} \\ | \\ \alpha \end{array} \quad \text{---}\rightarrow \quad \begin{array}{c} \text{V} \\ | \\ \text{e} \end{array} / [+Change] + \begin{pmatrix} \text{C} \\ | \\ \text{X} \end{pmatrix} \underline{\quad}$$

$$\text{II.} \quad \begin{pmatrix} \text{V} \end{pmatrix} \quad \text{---}\rightarrow \quad \begin{array}{c} \text{V} \\ | \\ \text{e} \end{array} / [+Change] + \begin{pmatrix} \text{C} \\ | \\ \text{X} \end{pmatrix} \underline{\quad}$$

$$\text{III.} \quad \begin{bmatrix} +\text{high} \\ \alpha \text{round} \end{bmatrix} \quad \text{---}\rightarrow \quad \text{e} / [+Change] + \begin{pmatrix} \text{C} \\ | \\ \text{X} \end{pmatrix} \underline{\quad} \quad \begin{array}{c} \text{V} \\ | \\ \text{C} \\ | \\ \text{+high} \\ \alpha \text{round} \end{array}$$

All of these rules are applicable only in a morphologically specified context, and at least the first and the third are

subject to additional morphological or lexical restrictions. Initial Change I is optional or blocked in various denominal verbs.<sup>4</sup> Moreover, this blocking appears to be a property of particular stems or classes of stems, not individual morphemes or particular morphological configurations. Initial Change III is lexically restricted to specified initials.

Since there are apparently no rules which must precede those of (50), we might in fact question the status of these generalizations as phonological rules. They could easily be reinterpreted as rules of allomorphy, perhaps as redundancy rules over Changed and Unchanged stems, where these are listed with distinct underlying forms. Under this interpretation, the Changed stem of a verb would not be created by rule in the presence of a trigger like the feature [+Change], but would instead be selected from the lexicon for insertion in a syntactically specified environment. This approach might go part of the way toward explaining the restrictions on the expression of Change in denominal verbs. Speakers are apparently reluctant to produce distinct Changed forms for initials which are not ordinarily used in contexts which require Change, even in cases where the pattern to be followed is perfectly clear from the linguist's point of view. But such limitations on the productivity of lexical processes are commonplace. Idiosyncratic Changed forms are also easily accommodated in these terms. Since these can simply be listed in the lexicon, there is no need to postulate rules to derive them which would have to make arbitrary adjustments in the shape of particular morphemes in the context of Initial Change.



Although the formal status of the rules in (50) remains uncertain, the generalizations which these rules express can nonetheless be used as guides in setting up underlying forms for morphemes which may occur in the initial position in the verb complex. Since some morphemes have irregular Changed forms, however, such evidence from Change cannot always be considered conclusive. In particular, the fact that the third person prefix has the Changed form /we-/ does not establish that its basic shape is /wə-/ rather than /w-/, as I have argued in 5.4.

Initial Change II makes a distinction between underlyingly unstressable and inherently stressable vowels. Under a diacritic or metrical account of the stressable/unstressable distinction, this fact seems quite surprising. Why should a diacritic feature established to regulate the application of the stress rules play a role in a morphologically governed vowel mutation? Why should the application of mutation be blocked by a marker indicating the boundary of a metrical constituent to be constructed by a later rule? Given the CV theory of stressability, on the other hand, the presence of a V-slot distinguishes inherently stressable vowels from underlyingly unstressable vowels. Since this distinction is not intrinsically associated with the application of any particular type of rule, it is not surprising that it should be relevant in a variety of areas of the phonology of Passamaquoddy.

-- Notes --

1. Leavitt gives his examples in standard Passamaquoddy orthography and does not indicate stress. I have rewritten the forms he gives in the orthography used elsewhere in this work and supplied accents. The morphological analyses suggested here are also mine.

2. The reader might suspect that these restrictions reflect a recent trend toward paradigm leveling, but this does not seem to be the case. They appear to be shared by speakers of all ages, although there must be variation in the details. The texts published by J.D. Prince (1921) are phonologically quite conservative, but forms like the following conform to the contemporary pattern: "ewasiswultilit" ewas-is-əw-olti-li-t (child-DIM-AI-PL-OBV-3AN) 'when the others (pl.) were young' (Change overtly expressed by the shift of / / to /e/ in / was- /), "tan wut p'mausowin wipit" tan wət pəm-awso-wiŋwi-hpi-t (how this(an.) along-live-NOM-eat-3AN) 'anyone who eats people' (vowel mutation blocked in /p m- /). (Both forms p.32.)

3. It should be noted, however, that the uncertain status of the contrast between ə and o before w makes this evidence less compelling than it might appear. (See 3.3.)

4. It seems likely that all three rules are sometimes blocked or optional in denominal verbs. For example, I have the impression that the shift of i to e is optional in (41b), although I do not find the unmutated form in my notes.

## Chapter 10

### Final Vowel Deletion

The pitch accent system of Passamaquoddy is one of the most interesting areas in the phonology of the language, but one that remains largely unexplored. A detailed analysis of the rules of pitch assignment is beyond the scope of the present work, and in any case there is much in this domain that remains mysterious. This chapter aims only to point out a few of the relevant generalizations and to illustrate some of the issues which a more complete analysis will have to confront.

Since the accentual notation which I have employed in this work is derived from that proposed in Goddard (1970), I begin in section 1 by comparing Goddard's conception of the prosodic system of Maliseet-Passamaquoddy with that which I have been assuming here.

In addition to suggesting an accentual notation, Goddard (1970) identified the central generalization concerning pitch accent in Maliseet and Passamaquoddy: the last stressed syllable in a word is associated with low pitch instead of high pitch in forms which have undergone a historical process resulting in the loss of final vowels. A rule of Final Vowel Deletion continues to apply in the phonology of Passamaquoddy, reflecting this historical change. Moreover, the application of Final Vowel

Deletion continues to result in accentual adjustments: whatever the metrical status of a penultimate syllable prior to deletion, this syllable is stressed and low-pitched in the resulting form, with a rising intonation before a pause. The synchronic motivation for Final Vowel Deletion and the accentual correlates of the rule are discussed in section 2. A similar rule is found in Maliseet, with comparable effects on stress and intonation patterns at least in some dialects, but additional factors appear to be involved in Maliseet intonation which cannot be considered here.<sup>1</sup>

Some affixes which always occur in final position have accentual properties which reflect the former presence of a final vowel. In many cases of this kind, however, there is no synchronic evidence of an underlying final vowel apart from these accentual effects. It seems likely, then, that certain affixes must be analyzed as inherently stressed or as pre-stressing morphemes in a synchronic account of Passamaquoddy phonology.

More interesting questions arise when a word-final affix which never surfaces with a vowel participates in phonological processes in addition to accent assignment as if it added a syllable to the underlying form of the base to which it is attached. In a case of this kind, it may be appropriate to postulate an underlying representation for the affix which ends in an abstract vowel or an empty V-slot. Two affixes for which an analysis of this kind seems plausible are discussed in section 3: the perfective and subjunctive suffixes of the Conjunct Order, which appear to consist only of a V-slot.

## 10.1 Two conceptions of Passamaquoddy prosodics

Goddard (1970) suggested that the basic intonation pattern of Maliseet words is one of alternating high and low pitch: successive syllables are alternately assigned high and low pitch, except that certain syllables with "short vowels" (the unstressable vowels of the present work) are skipped over in assigning this contour. In addition to this principle of alternating pitch, Goddard's account requires a principle of alignment: in some words, the syllable which receives main stress is aligned with a relative high in the intonation contour, while in other words the most prominent syllable is aligned with a relative low. Finally, a principle of pitch contour formation results in the assignment of rising or falling pitch to certain syllables in short words where there are not enough syllables to map each element in a minimal permitted span of the alternating pattern onto a separate syllable with a full vowel. Given these principles, Goddard conjectured, it should be sufficient to mark the position and pitch of the main stress in a word. The rest of the contour should in general be recoverable from this information, with the possible exception of cases involving irregular treatment of "short vowels."

There are several problems with Goddard's proposal. First, contour pitch is not limited to words which are too short to allow the assignment of a simple alternating pattern. In a Maliseet word like étəlíhtemàn 'he is hitting it,' for example, the penultimate syllable is pronounced with a falling intonation and the final syllable with a rise. Second, in Passamaquoddy, at

least, adjacent syllables with "long vowels" are sometimes pronounced on the same pitch. We noted in 3.5, for example, that some speakers pronounce both the antepenult and the penult on a high pitch in words like nátakehkimkèn 'go (sg.) to school!', in which an unstressed penult stands between a syllable which bears the acute accent and one which bears the grave accent. We have also seen in 3.5 that initial and final unstressed syllables may be relatively high-pitched even when they are adjacent to high-pitched stressed syllables.

More seriously, there is reason to doubt that high and low pitch are assigned to stressed syllables as part of an overall contour. We will see in the following section that high-pitched stresses are assigned to words which undergo Final Vowel Deletion prior to the elimination of word-final vowels. These stresses and the pitch levels associated with them do not shift when low pitch (and sometimes stress) is assigned to the syllable which is left in final position by deletion. In effect, then, high-pitched stresses and low-pitched stresses are assigned independently. This observation suggests that it is inappropriate to view the alignment of the syllables of a word with an alternating contour as the basic principle of Maliseet-Passamaquoddy prosodics.

If we do not analyze the alternating high and low pitch which is characteristic of unmarked intonation in Passamaquoddy in terms of a basic intonational pattern, then we will need to postulate phonological rules for the language which derive pitch contours, rather than rules which align a basic contour with the syllables of a word or state deviations from this pattern. An

account of this type might run as follows. Suppose that an autosegment H (for high) is associated with each stressed syllable in the unmarked case. Initial stressless syllables and utterance-final unstressed syllables may also be associated with high pitch by rule. If we then assign L (for low) to any remaining unstressed syllables with stressable vowels, we will derive the alternating intonation pattern which Goddard takes as basic. Medial syllables with unstressable vowels seem in general to be pronounced on a pitch intermediate between the pitch of the adjacent syllables. Perhaps this effect can be handled by rules of phonetic implementation.<sup>2</sup>

Affixes which impose the grave accent on a word-final syllable may be represented with an accompanying L in underlying forms. If the affix itself contains a vowel, the low pitch introduced with the affix will be associated with this vowel, as in a form like hkwayə-w-à (angry-3-3AN.ABS) 'he (abs.) is angry,' with the proximate absentative singular agreement suffix /-a/, which always bears the grave accent. If the affix consists only of one or more non-syllabics, its L will be associated with the last preceding vowel, as in míl-i-n (give-1.OBJ-2) 'give (sg.) it to me!,' with the pre-accenting imperative singular suffix /-n/.

It is not clear whether the rising intonation of low-pitched stressed syllables in utterance-final position reflects an underlying word-final H or an H introduced by rule. There are a number of possibilities if we suppose that an underlying H is involved. We might, for example, take LH rather than L to be the underlying "melody" represented by the grave accent. Alternatively, we might postulate a boundary tone H in pre-pausal

forms. Perhaps the relatively high pitch of utterance-final unstressed syllables could be analyzed as a reflection of the same boundary tone. (It should be noted, however, that the low pitch associated with the theme sign /-a/ 3PASS in word-final syllables is not realized as a rise before a pause.)

Clearly these remarks constitute only a program for the analysis of Passamaquoddy intonation, not a theory of the facts in this domain. I hope to present a more complete account of the phenomena of pitch accent in Maliseet and Passamaquoddy in future work.

## 10.2 Final Vowel Deletion

The segmental effects of Final Vowel Deletion are easy to formalize, but the accentual changes which the rule induces are more tricky to state. We cannot simply attribute the accentual correlates of deletion to the presence of an underlying word-final vowel, since accent is affected only when a vowel is actually deleted. A number of affixes are consistent exceptions to Final Vowel Deletion, and one is an optional exception. When a final vowel is retained in one of these exceptional cases, stress and intonation follow the patterns that we find in words whose underlying forms end in a non-syllabic. Thus we must tie the accentual effects of the rule to the actual loss of a vowel. One formal way to achieve the necessary results is to divide the process of deletion into two stages. We can first delete the segmental material of a final vowel, then state the accentual change over a representation which contains a final empty V-slot, finishing the deletion process by eliminating the slot itself. I



will assume this analysis here, although I will not attempt to formalize the rules which determine intonation in the output of Final Vowel Deletion. It seems clear, however, that a procedure of this kind is more a notational trick than a real solution. In any case, I begin here by illustrating the vowel/zero alternations produced by Final Vowel Deletion, then turn to the question of the rule's accentual correlates.

Stem-final vowels are lost quite regularly in nouns and verbs -- the major categories of the language -- after any non-syllabic except /h/. Particles are not usually subject to Final Vowel Deletion, however, nor are preverbs and pre-nouns, whether or not they are accentually or syntactically treated as independent words. Let us then state Final Vowel Deletion as a rule which is restricted to the categories N and V. (I use the feature "laryngeal" here only as shorthand for the feature or features, whatever they may be, which distinguish /h/ from other non-syllabics.)

(1) Final Vowel Deletion

	C	V	
v -->	∅	/ [-laryngeal]	]
		---	N, V

The application of Final Vowel Deletion to noun stems ending in /i/, /e/, and /a/ is illustrated in (2)-(7). In each case I first give an unsuffixed form in which a final vowel has been deleted, then a suffixed form in which the stem-final vowel is retained. Comparable examples of deletion in verb stems are

given in (8)-(13). (I set aside here the question of deletion in noun and verb stems ending in /o/, since it is not clear whether final /o/ or final /əw/ is actually involved in these cases.<sup>3</sup> No stems end in /ə/.)

(2) a. m̀an

'money'

b. n-máni-m

1-money-POSS

'my money'

(3) a. ípis

'whip, switch'

b. nt-ípisi-m

1-switch-POSS

'my whip, switch'

(4) a. skítap

'man'

b. n-óskítape-m

1-man-POSS

'my man, my husband'

(5) a. ótèn

'town'

b. óténe-k

town-LOC

'town (loc.)'

- (6) a. póhtay  
       'battle'
- b. n-póhtáya-m  
           1-battle-POSS  
           'my battle'
- (7) a. htáma-w-èy  
       smoke-DA-NF  
       'tobacco'
- b. htámá-w-eya-w  
           smoke-DA-NF-3IN.ABS  
           'tobacco (abs.)'
- (8) a. k-pòs  
       2-embark  
       'you (sg.) leave by boat'
- b. k-pósí-hpən  
           2-embark-PRET  
           'you (sg.) left by boat'
- (9) a. n-ó-maní-m  
       1-3-money-POSS-(AI)  
       'I have money'
- b. má te n-ó-maní-m-i-w  
           not EMPH 1-3-money-AI-NEG  
           'I do not have money'

- (10) a. kt-ám  
 1-fish  
 'I fish'
- b. kt-ámé-pa  
 2-fish-22  
 'you (du.) fish'
- (11) a. k-óniyakóni-n  
 2-head-ache  
 'you (sg.) have a headache'
- b. k-óniyákóni-né-pa  
 2-head-ache-22  
 'you (du.) have a headache'
- (12) a. k-ótám  
 2-smoke  
 'you (sg.) smoke'
- b. k-ótámá-pa  
 2-smoke-22  
 'you (du.) smoke'
- (13) a. n-kásinòhk  
 1-sick  
 'I am sick'
- b. ksínòhka-k  
 sick-(3)-33PROX  
 they (du.) are sick'

The (a) forms in (8)-(13) should be compared with those in (14) and (15). Although these are also first and second person

singular Independent Indicative forms, their final syllables are unstressed. Since the stems /pet-əkil-/ 'reach a size (in growth)' and /tahkikw-əl-/ 'be heavy' end in non-syllabics, Final Vowel Deletion is not applicable in these cases and no adjustment of the expected output of the Passamaquoddy stress rules is required.

(14) a. n-pét-kil

1-arrive-size

'I reach a size'

cf. b. pét-kíl-ok (/pet-əkil-w-ək/)

arrive-size-(3)-33PROX

'they (du.) reach a size'

(15) a. k-táhkíkw-əl

2-heavy-AI

'you (sg.) are heavy'

cf. b. téhkíkw-əl-ək (/tehkikw-əl-k-V/)

heavy-AI-3AN-(PERF)

'when he was heavy'

Stem-final /a/ and /e/ surface in word-final position in the basic third person singular forms of AI verbs, as shown in (16). In these cases, however, we can attribute the retention of final vowels to the underlying presence of the third person suffix /-w/, provided that the rule which deletes word-final /w/ in these forms is ordered after Final Vowel Deletion.

- (16) a. áme  
 fish-(3)  
 'he fishes'
- b. w-ániyakáni-ne  
 3-head-ache-(3)  
 'he has a headache'
- c. htáma  
 smoke-(3)  
 'he smokes'
- d. ksínóhka  
 sick-(3)  
 'he is sick'

We noted in 8.1.3 that a variety of nouns (mostly borrowings) also surface with final vowels in their unmarked singular forms: ápasénta 'sundog,' kahpe 'coffee.' Suffixed forms suggest that the application of Final Vowel Deletion is blocked in these cases as well by the presence of an underlying final /w/: ápasentáw-ək (sundog-33PROX) 'sundogs,' káhpéw-əl (coffee-33IN) 'cups, jars, etc. of coffee.' Any rule deleting final /w/ which will apply to both nouns and verbs will have to be quite complex, however, since word-final /w/ is lost after /i/ in nouns but retained in the same environment in verbs.<sup>4</sup> This we have tí 'tea' from /tiw/ (as in the plural form tíw-əl), but máni-m-ì-w 'he has money' from /w-mani-m-i-w/ (3-money-POSS-AI-3). I-stem forms like máni-m-ì-w are particularly curious, because they are accented as if the suffix /-w/ were itself followed by some underlying final vowel, even though no such

vowel shows up on the surface in suffixed forms like the obviative singular máni-m-í-w-əl.<sup>5</sup> I-stem forms which undergo I-Mutation are not accented on this pattern: compare the alternate form máni-m-o, with /ə/ for /i/ before /w/ and contraction of final /əw/ to o.

Final Vowel Deletion must be prevented from deleting vowels after /h/ to account for the retention of stem-final vowels in forms like (17a) and (18a). The stems in these examples have the same surface shape in unsuffixed forms as they do in suffixed forms like (17b) and (18b).

- (17) a. n-sákh-ətkwíhi  
 1-into.view-jump  
 'he jumps into view'
- b. n-sákh-ətkwihí-pən  
 1-into.view-jump-11  
 'we (du. exc.) jump into view'
- (18) a. k-máca-ha  
 2-start-go  
 'you (sg.) leave'
- b. k-máca-há-pa  
 2-start-go-22  
 'you (du.) leave'

Particles apparently do not undergo Final Vowel Deletion in contemporary Passamaquoddy. Final vowels are retained, for example, in katáma 'not,' élowe 'almost' and mécími 'always.' Many particles end with a low-pitched stressed syllable, however,

presumably as the historical result of the loss of a final vowel: lámi-kəwám (inside-house) 'inside (a building),' tàn 'how,' kís 'already.' In some cases there are related items in which the vowel is preserved: táne-(hk) 'ever since,' kisi 'past' (preverb). Preverbs and pre-nouns are also exempt from Final Vowel Deletion, whether or not they are treated as a constituent with the word which they modify:

- (19) a. ksánéwi piye  
           strong beer  
           'strong beer'
- b. n-máce w-ániyakóni-n  
           1-start       3-head-ache  
           'I am starting to have a headache'
- c. skínóhs-is h-kís! pílsqehs-ís-əl  
           boy-DIM       3-past girl-DIM-3.OBV  
           tək-am-a-l.  
           hit-TA-DIR-3.OBV  
           'The boy hit the girl.'

Many suffixes are exceptions to Final Vowel Deletion. Among these are the direct theme sign /-a/, the theme sign /-a/ of third person unspecified subject forms, and the theme sign /-i/ of first person object forms. The theme sign /-ke/ of unspecified subject forms with first or second person objects, on the other hand, undergoes deletion regularly. Other exceptional suffixes include the first person plural ending /-ne/ of Imperative forms and the second person plural suffix /-pa/ of the Independent Indicative Mode. Some examples are given in (20).



- (20) a. n-más-ən-a  
 1-get-by.hand-DIR  
 'I catch him'
- b. k-nást-ów-i  
 2-understand-TA-1.OBJ  
 'you (sg.) understand me'
- c. míl-í-ne  
 give-1.OBJ-11  
 'give it/them to us'
- d. k-pósi-pa  
 2-embark-22  
 'you (du.) embark'
- cf. e. n-más-ən-ək (/n-məs-ən-əke/)  
 1-get-by.hand-PASS  
 'I get caught'

Some affixes have a non-final form which ends in a vowel and a final form without it, but show other differences in form which suggest that the alternation should not be attributed to Final Vowel Deletion in a synchronic grammar. An example is the first person plural affix /-nno-/ ~ /-n/:

- (21) a. k-wíkí-ne-nnó-hpən  
 2-dwell-SUBORD-11-PRET  
 'we (inc.) lived (there)'
- b. k-wíki-ne-n  
 2-dwell-SUBORD-11  
 'we (inc.) live (there)'

Here the final form has a single n where the non-final form has two. We could, of course, postulate a rule changing /nn/ to n in final position. Such a rule would, in fact, be exceptionless, since nn does not occur word-finally. There is no other motivation for a rule of this kind, however, since nn does not otherwise alternate with n in final position and other word-final geminates surface unchanged. Thus the putative degemination rule reduces to a statement about the suffix /-nno-/ and seems no better motivated than a rule of allomorphy particular to this suffix.

There are, in fact, only a few affixes which clearly undergo Final Vowel Deletion. The negative suffix /-w/ ~ /-wi/ is an especially interesting example. This affix has the underlying form /-wi/ in AI and TA forms of the Independent Indicative Mode that involve a third person as either a subject or an object. In AI forms with first or second person subjects and in TA forms with first or second persons as both subject and object, the allomorph /-w/ is used instead. Both allomorphs add an initial /o/ after a non-syllabic. (II Independent Indicative forms resemble AI third person forms in the relevant respects, but the negative TI paradigms are organized along different lines.) Some examples are given in (22)-(26).

- (22)    níl mǎ    ǎpc    nát-áme-w.  
           I    not again (1)-go-fish-NEG  
           'I will not go fishing again'

(23)

a. nékám má àpc nàt-amé-w.  
he not again go-fish-(3)-NEG  
'He will not go fishing again.'

= b. nékám má àpc nàt-amé-wi.

(24) a. kətáma k-néhpo-h-ól-o

not 2-kill-TA-2.OBJ-NEG

'I do not kill you (sg.)'

b. \*kətáma k-nehpo-h-ol-owi

(25) a. má te kt-íy-w-à-w

not EMPH 2-have-TA-DIR-NEG

'you (sg.) do not have him'

= b. má te kt-íy-w-á-wi

(26) a. má te nómí-y-okò

not EMPH (1)-see-INV-(NEG)

'he does not see me'

= b. má te nómí-y-okó-wi

What makes the negative suffix interesting for the analysis of Final Vowel Deletion is the fact that the allomorph /-wi/ undergoes deletion optionally. With this in mind, we can account for the stress and intonation of the forms in (22)-(26) as follows.

The syllabified underlying representation of the first person form nátámew is (27).

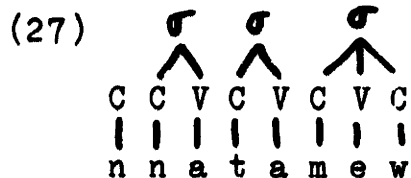

Stress is assigned to this word in the usual fashion by the Alternating Stress Rule and the Initial Stress Rule, which, with stress subordination, yield the metrical grid shown in (28). (The /n/ of the first person prefix is ultimately deleted before /n/.)

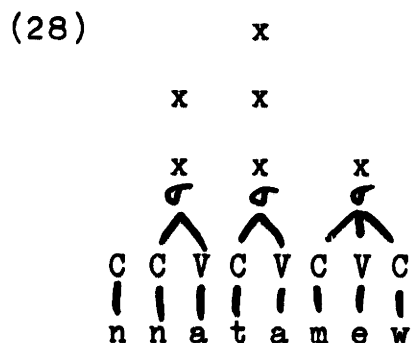

Since Final Vowel Deletion is not applicable here, no accentual adjustments are made; the final syllable of the word does not bear the grave accent.<sup>6</sup>

The syllabified underlying representation of the third person form nátaméwi is (29a). Here stress assignment gives us the grid shown in (29b).

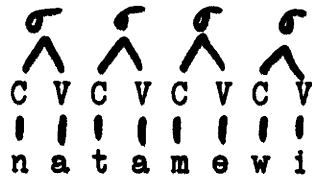
(29) a. 

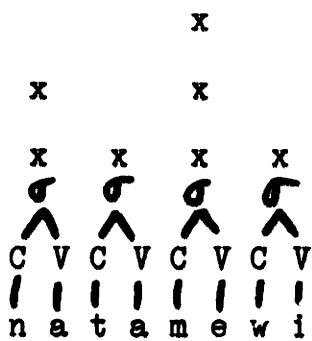
b. 

In this case, Final Vowel Deletion is potentially applicable; but, irregularly, the rule is not applied.<sup>7</sup> Here again, then, no accentual adjustments are made.

The alternative third person form nátamèw has the same underlying form as nátaméwi. The differences between the two are due solely to the application of Final Vowel Deletion. Now if this rule directly changes (30a) to (30b), there is no obvious way to state the environment which conditions the appearance of the grave accent on the final syllable of nátamèw.

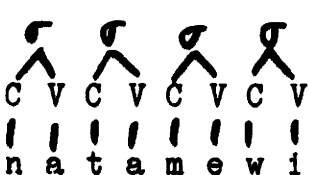
(30) a. 

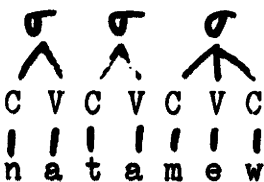
b. 

We cannot say that the stressed /e/ in (30a) is associated with low pitch because the representation contains a final vowel,

since low pitch is not assigned to the stressed e of nátaméwi. We cannot attribute the grave accent in nátamèw to the segmental environment of /e/ in (30b), or to the CV structure of this representation, since the underlying representation of the first person form nátamew is identical in these respects. Nor can we simply say that stressed final syllables are low-pitched, since both high and low-pitched stress is found in monosyllables and in bisyllabic words with final stress: kát 'leg' contrasts with kàt 'eel' (the latter from underlying /kate/); apó 'he sits' contrasts with apò 'the others sit' (from /əpi-w-ə/ (sit-3-330BV) or the like).

We can get the right results, however, if we assume that the output of Final Vowel Deletion is (31) instead of (30b), that is that Final Vowel Deletion eliminates the segmental material of a word-final vowel, but not the associated V-slot.

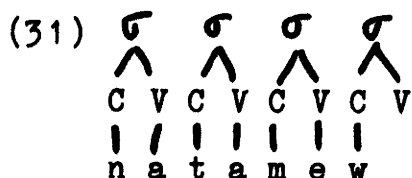

Since empty V-slots do not otherwise occur in underlying representations -- except perhaps in cases like those discussed in section 3 -- we are free to state our accent adjustment rule in terms of them: assign low pitch to the syllable immediately preceding a final syllable with an empty V-slot. Just how such a procedure should be formally implemented is not obvious, and I will not attempt to address this question here. It seems clear, however, that the hypothesized formulation of Final Vowel Deletion creates a structural distinction which can be employed

in an appropriate formal statement (granting that an alternative treatment which permitted a more intuitive account of Final Vowel Deletion would be preferred). The slot left vacant in (31) must ultimately be eliminated, however, since the surface syllabification of nátamèw is surely that shown in (32).

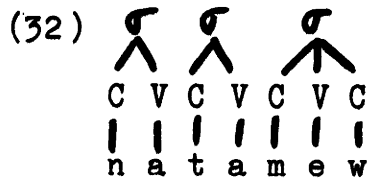

The procedure just outlined may also be used to account for the stress and intonation of the examples in (24)-(26). Parallel derivations can be given for the other forms which have been cited in this chapter as cases of Final Vowel Deletion. For example, the derivation of n-kásinòhk 'I am sick' will run as follows. The /ə/ of the stem /kəsinohka-/ is underlyingly unstressable, as we know from the fact that this vowel undergoes syncope in ksínóhka (sick-(3)) 'he is sick.' Thus the syllabified underlying form of n-kásinòhk must be (33a). This /ə/ receives a V-slot by V-Epenthesis, giving (33b). Stress assignment derives (33c). Final Vowel Deletion then eliminates the stem-final /a/, leaving its V-slot behind. (Note that Final Vowel Deletion, formulated as deletion on the segmental tier alone, could actually precede stress assignment, since only CV structure is relevant to stress placement.)

(33) a.

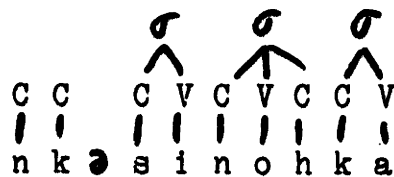

b.

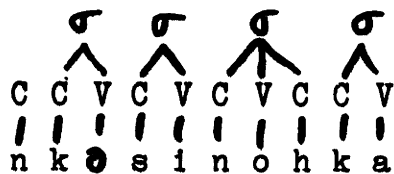

c.

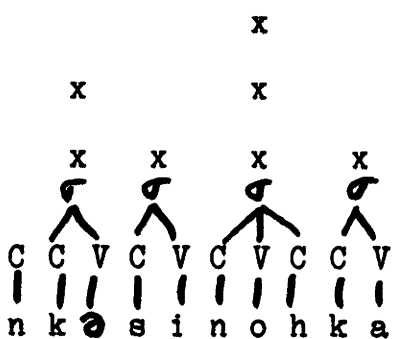

d.

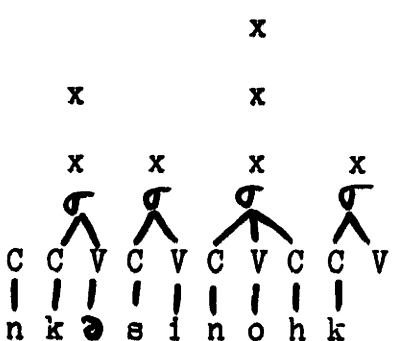

e.

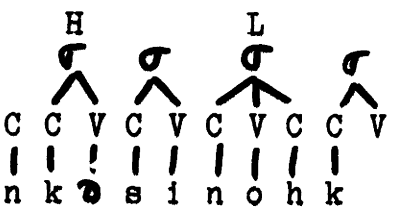

Low pitch will now be assigned to the underlying penult, but the other stressed syllable in the word will receive high pitch, since high pitch is assigned to stressed syllables in the unmarked case. The intonation of n-kə-si-nohk is thus determined by the pitch assignments shown in (33e), with dialect variation



in the treatment of the medial syllable of the word, some speakers spreading the preceding high onto this position, others the following low. In utterance-final position, the final low is realized as a rise. Ultimately the final V-slot in (33e) is deleted and the preceding /k/ is resyllabified to the left.

Now the location of stress in a form like nkásinòhk is entirely determined by its representation prior to the loss of the V position left vacant by Final Vowel Deletion. It is not the case, however, that all stress assignment is carried out prior to the deletion of word-final vowels. Neither the Initial Stress Rule nor the Alternating Stress Rule will assign stress to a penultimate vowel which is unstressable in their input. A penultimate vowel which is invisible to these rules will nonetheless surface as stressed in a word in which a final vowel has been deleted.

An example of the appropriate form is ámocálo 'fly (insect),' underlying /amocaləwe/. (Compare the possessed form ht-ámocaləwé-m-əl (fly-POSS-3.OBV) 'his fly.'). The syllabified underlying representation of this word is (34a). Stress is assigned by the Initial Stress Rule and the Alternating Stress Rule as shown in (34b).

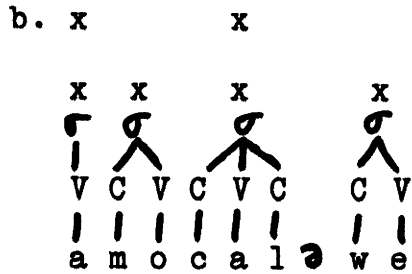
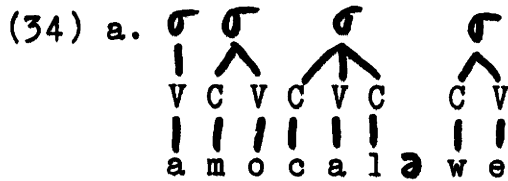

Final Vowel Deletion eliminates the last vowel in this representation and word-final /əw/ is ultimately realized as o, but the resulting word-final vowel is not only low-pitched but stressed -- in fact it bears the main stress of the word. Thus the surface form of ámocálo must have the representation shown in (35).

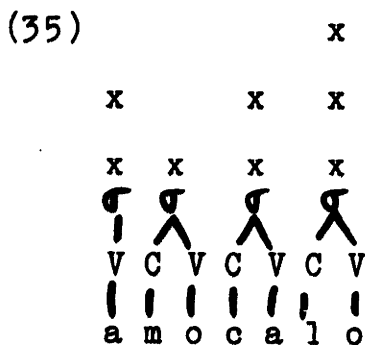

Note that the stress assigned here in the wake of Final Vowel Deletion is adjacent to a stress assigned by the Alternating Stress Rule -- alternating stress does not shift when a stress is assigned as a result of the application of Final Vowel Deletion.

We can obtain the necessary results if we postulate a rule which stresses a word-final vowel which is associated with low pitch as a result of the application of Final Vowel Deletion. A

mechanism which will provide a V-slot for this vowel is also required, however, since a vowel must be associated with a V-slot if it is to count as a tone-bearing unit or receive stress.<sup>8</sup> In any case, this stress assignment process must precede stress subordination, since the stress which it introduces must be the rightmost stress in the word when the Main Stress Rule is applied.

### 10.3 Word-final abstract vowels

Several word-final affixes which never surface with a final vowel nonetheless affect the stress pattern of the base to which they attach just as if they were subject to Final Vowel Deletion. The second person singular Imperative ending -n is a typical example. Imperatives formed with this suffix always have final low-pitched stress. Moreover, their other stressed syllables are shifted to the right with respect to the pattern that we would expect on the basis of the surface segmental forms. The imperative suffix -n contrasts with the word-final variant of the Subordinative ending /-n/ ~ /-ne/ in this respect, as we can see by comparing the Subordinative form in (36a) with the Imperative in (36b).

- (36) a. ná-t-ə-keh-kím-ke-n  
 (1)-go-teach-PASS-SUBORD  
 'I go to school (Subordinative)'
- b. ná-t-ə-keh-kim-kè-n  
 go-teach-PASS-2  
 'go (sg.) to school!'

Deriving the right stress pattern for (36b) presents no problem. (An epenthetic /ə/ is subject to syncope before the /k/ of the theme sign /-əke-/, but has no effect on stress placement. The /ə/ of /-əkəhkim-/ 'teach' is unstressable but is an exception to Syncope I.) The derivation of nát-əkəhkim-ké-n would also be straightforward, if the underlying form of the Imperative suffix were /-nV/, where V is some vowel. This would give (37a) as the syllabified underlying representation (following epenthesis) of (36b). The output of the stress rules would then be (37b), with Final Vowel Deletion eliminating the hypothetical final vowel and triggering the assignment of low pitch to the syllable left in final position. (Here again epenthetic /ə/ is subject to syncope.)

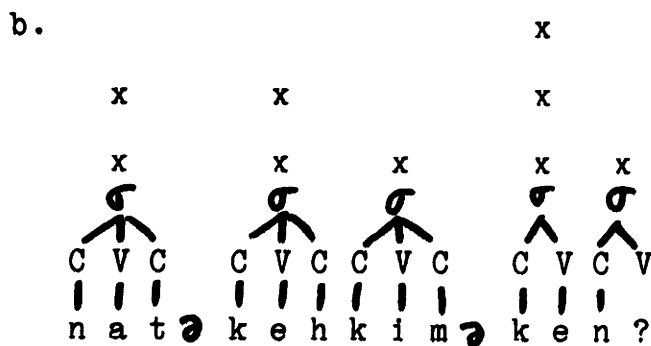
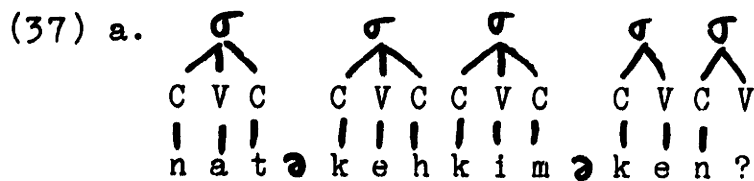

Now there is no evidence apart from the facts of stress and intonation which would lead us to postulate an underlying form for the Imperative suffix -n which ends in a final vowel. It therefore seems impossible to exclude accounts of the accentual properties of this morpheme which would not rely on an abstract

underlying rerepresentation. We might, for example, take the imperative -n to be a trigger of an accent assignment rule in the sense of Halle and Vergnaud -- a rule which marks the last preceding vowel as the head of a metrical constituent (on the foot level this time, rather than on the subfoot level), thus requiring the Alternating Stress Rule to begin syllable counting with the penultimate syllable of the word rather than the last. Of course we also need to account for the intonation of forms like nát-əkéhkim-kè-n as well as their stress. We would probably want to build a provision assigning low pitch into our accent assignment rule, since there are no pre-accenting morphemes in Passamaquoddy which do not induce low-pitched stress.

An account in terms of accent assignment is not sufficient to handle all of the phonological effects of certain word-final affixes, however. The perfective and subjunctive suffixes of the Conjunct Order are particularly interesting in this respect. These affixes never have any surface segmental shape. Nonetheless, three kinds of phonological evidence point to underlying forms for these elements which consist only of an abstract vowel -- in some sense. First, forms made with either suffix always end in a low-pitched stressed syllable. In addition, the first person singular suffix /-a/ ~ /-an-/ shows up word-finally in what is otherwise its non-final shape before either of them. Finally, syncope is permitted in apparently word-final syllables in forms ending in either suffix, indicating that the application of Final Syllable Epenthesis is blocked in these contexts. No special statement concerning Conjunct perfectives and subjunctives is required to account for any of

these facts if adding one of these suffixes to a word introduces an additional syllable.

The choice of a particular vowel as the underlying representation of either of these morphemes is necessarily arbitrary.<sup>9</sup> For this reason, I suggest instead that the underlying form of the perfective and subjunctive suffixes is simply an empty V-slot. If we adopt the analysis of Final Vowel Deletion suggested above, this will mean that neither suffix is actually subject to the rule: neither contains any segmental material to be deleted. Rather, the presence of an underlying empty V-slot will itself condition the accentual adjustments otherwise associated with the application of Final Vowel Deletion.

The accentual contrast which distinguishes imperfective and perfective Changed Conjunct forms is illustrated in (38a,b). The corresponding subjunctive form (38c), without Change, has the same stress and intonation as the Changed perfective form.

- (38) a. élamí-ya-li-t  
away-go-OBV-3AN  
'when the other goes away'
- b. élamí-ya-li-t  
away-go-OBV-3AN-(PERF)  
'when the other went away'
- c. élamí-ya-li-t  
away-go-OBV-3AN-(SUBJ)  
'if the other goes away'

Postulating an abstract vocalic suffix in (38b) and (38c) which is absent in (38a) will account for the accentual contrasts among these forms just as postulating a final vowel in the Imperative suffix -n would account for the contrast between (36a) and (36b).

In perfective and subjunctive forms, the first person singular suffix appears as -an, adding epenthetic y after a vowel as discussed in 8.1.2.

- (39) a.  $\acute{a}ps-\acute{a}kil-\underline{an}$   
 small-size-1-(PERF)  
 'when I was little'
- b.  $\acute{e}si-h-m-\underline{an}$   
 give.drink-TI-TI-1-(PERF)  
 'when I watered it'

- (40) a.  $\acute{e}l\grave{a}m\acute{i}-ya-\underline{y\grave{a}n}$   
 away-go-1-(PERF)  
 'when I went away'
- b.  $\acute{e}l\grave{a}m\acute{i}-ya-\underline{y\grave{a}n}$   
 away-go-1-(SUBJ)  
 'if I go away'

In imperfective forms, however, there appears on the surface to be no suffix corresponding to -an. Nonetheless, both the use of epenthetic y and the accentuation of these forms points to the presence of an underlying vocalic suffix:

- (41) a.  $\acute{e}l\text{ə}mi\text{-}y\grave{a}\text{-}y$   
 away-go-1  
 'when I go away'
- b.  $k\acute{i}s\text{-}s\grave{i}\text{-}m$   
 past-give.drink-(TI)-TI-(1)  
 'when I water it'

The situation is similar in participles in which no further suffix follows the first person singular ending:

- (42) a.  $\acute{e}l\text{-}\text{ə}kw\grave{a}t\text{-}\grave{a}\text{-}y$   
 thus-clothing(?)-AI-1  
 'my suit'<sup>10</sup>
- cf. b.  $\acute{e}l\text{-}\text{ə}kw\acute{a}t\text{-}a\text{-}t$   
 thus-clothing(?)-AI-3AN  
 'his suit'
- (43) a.  $p\acute{a}w\text{a}\text{-}t\text{-}\text{ə}m$   
 want-TI-TI-(1)  
 'what I want'
- b.  $\acute{e}s\grave{i}\text{-}m$   
 give.drink-(TI)-TI-(1)  
 'I who will water it'

Since there is evidently some underlying final vowel in these forms, it seems plausible that it is /-a/, that is that /-an-/ has an allomorph without its final /n/ which appears in Conjunct imperfective forms and in unsuffixed participles.



Now whenever /-a/ ~ /-an-/ is followed by an overt suffix, the longer allomorph is used. So, for example, we always find -an before the preterite suffix -pən or the dubitative suffix -s:

- (44) a. mēs-ə<sup>́</sup>n-ə<sup>́</sup>m-án-pən  
 get-by.hand-TI-1-PRET  
 'when I got it'
- b. éli páwa-t-ə<sup>́</sup>m-án-pən  
 thus want-TI-TI-1-PRET  
 'what I wanted'
- c. élí ms-ə<sup>́</sup>n-ə<sup>́</sup>m-àn-s  
 thus get-by.hand-TI-1-DUBIT  
 'what I got (dubitative)'
- d. wéci nəmí-htəw-àn-s  
 from see-TI-1-DUBIT  
 'why I saw it (dubitative)'

We can bring Conjunct perfective and subjunctive forms like those in (39) and (40) under the same generalization if we assume that /-an-/ is followed by a suffix in these forms as well: the abstract vocalic suffix /-V/. If the perfective and subjunctive suffixes are phonologically constituted in underlying forms, then we can simply say that /-a/ is used in underlying word-final position, /-an-/ elsewhere.

A third line of evidence for an underlying suffix marking perfective and subjunctive forms comes from syncope. While an underlyingly unstressable /ə/ is always maintained on the surface before a word-final obstruent in Conjunct imperfective forms, the corresponding vowel may undergo syncope in perfective and

subjunctive forms. The examples in (45) and (46) illustrate the difference between imperfectives and perfectives in this regard. (The treatment of subjunctives in syncope is parallel to that of perfectives.)

- (45) a. kwéni máw-əlohk-é-mək  
length group-work-AI-UNSPEC  
'while they (unspecified) were working'
- b. máw-əlohk-è-mk  
group-work-AI-UNSPEC-(PERF)  
'when they (unspecified) worked'

- (46) a. kémiw-k (stem /kamiwən-/)
rain-3IN  
'when it rains'
- b. kémiw-k  
rain-3IN-(PERF)  
'when it rained'

Since /ə/ is not ordinarily subject to syncope where it is the last vowel in the underlying form of a word, the deletion of /ə/ before word-final /k/ in (45b) and (46b) is surprising -- unless we adopt the proposed hypothesis of a phonologically constituted form for the perfective suffix. The derivations of these forms are straightforward, however, if the underlying form of the perfective affix contains a V-slot.

Consider first the derivation of the imperfective form kémiwə-k. The syllabified underlying form of this word, following the morphologically conditioned deletion of the final

/n/ of the Changed stem /kemiwən-/, is (47a). Final Syllable Epenthesis is applicable in this structure, since it contains a floating /ə/ which is followed by a word-final C. Application of this rule derives (47b). Since the /ə/ of /kemiwək/ is no longer a floating vowel in the output of V-slot epenthesis, no rule of syncope is applicable.

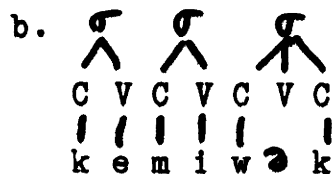
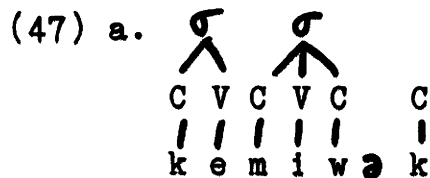

The syllabified underlying form of kémiw-k, on the other hand, is (48a). Final Syllable Epenthesis is not applicable here: although the floating /ə/ in this structure is the last vocalic element on the segmental tier, the following C is not final in the word. Syncope I therefore converts (48a) into (48b), a representation from which the accent adjustment rules suggested above and the rule deleting empty final V-slots will correctly derive kémiwk.

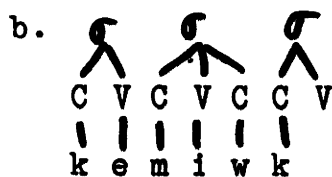
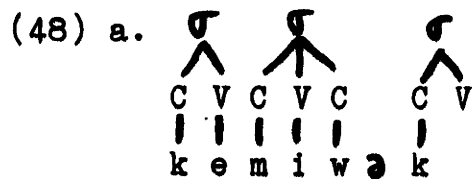

Now in 5.2.1 I argued that the principle which makes /ə/ stressable when it is the last underlying vowel of a word, Final Syllable Epenthesis in the CV theory of stressability, must be ordered prior to Final Vowel Deletion. We can see now, however, that this ordering is not strictly necessary. Once we decide to formulate Final Vowel Deletion as deletion on the segmental tier alone, it no longer matters whether deletion takes place before or after the application of Final Syllable Epenthesis. As long as Final Vowel Deletion leaves a V-slot behind, Final Syllable Epenthesis will be blocked in underlyingly vowel-final words whether or not it precedes Final Vowel Deletion. Nonetheless, it remains necessary to order Final Syllable Epenthesis before the rule which eliminates word-final empty V-slots.

Note, however, that the account of Final Vowel Deletion that I have offered here, and to an even greater extent the suggested analysis of the contrast between forms like kémiwə-k and kémiw-k, relies heavily on the formal manipulation of highly abstract structures. Given the extensive variation and the evidence of paradigm leveling that we have seen in other areas of Passamaquoddy phonology, it would be very surprising if this part of the system were immune to instability. And indeed forms which

depart from the predictions of the proposed analysis are not uncommon. A number of words like tàp ~ táp 'bow' may be heard either with or without the accentuation expected for underlyingly vowel-final words, despite the evidence for an underlying stem-final vowel from forms like ht-áh-tapí-m-əl (3-AUG-bow-POSS-3.OBV) 'his bow.' More seriously, there is systematic variation between forms like máw-əlohk-è-mk and kémíw-k, with syncope before the perfective suffix, and alternative forms like máw-əlóhk-e-mək and kémíw-ək, with the stress and intonation of underlyingly vowel-final words, but with treatment of /ə/ before a surface final obstruent as if Final Syllable Epenthesis had been applied. This variation is not limited to younger speakers, but appears to be typical of speakers of all ages.

A particularly interesting case is the following:

- (49) áps-əkíl-k  
 ~ áps-əkíl-ək  
 small-size-3AN-(PERF)  
 'when he was little'

We saw evidence in Chapter 7 that the /ə/ which appears before the allomorph /-k/ of the Conjunct suffix /-t/ ~ /-k/ 3AN is epenthetic. (See the discussion of él-kíl-ək (thus-size-3AN) 'he is big' in 7.1.) But epenthetic /ə/ is otherwise regularly subject to syncope, suggesting that a rule of V-slot epenthesis, presumably Final Syllable Epenthesis, has applied in the derivation of áps-əkíl-ək. Thus the variation that we find in forms like those in (49) casts doubt on the abstract analysis of the perfective and subjunctive suffixes. The question of the

underlying shape of these morphemes must be regarded as unsettled at this time.

-- Notes --

1. In particular, it appears that Maliseet has a rule which retracts low pitch to the (surface) penult in certain cases. Whether or not the underlying penultimate vowel is stressable also appears to make a difference to the outcome of pitch accent assignment in Maliseet. An accent retraction process similar to that of Maliseet applies for many Passamaquoddy speakers before the first person plural suffix /-pən/ of the Independent Indicative.

2. Ford (1983) suggests an autosegmental account of some aspects of word intonation in Cree-Montagnais which bear an interesting resemblance to the situation in Maliseet-Passamaquoddy.

3. Relevant examples include words like mōs 'moose,' obviative mōsōwəl (correctly transcribed?) and kt-əli-nt 'you (sg.) sing,' dual kt-əli-ntō-pa 'you (du.) sing.' From the stem of the latter we also have forms like əli-nta-kw 'the way he sings,' with stem final /a/ as if by contraction from /əw/ in underlying /əli-ntəw-k/ (thus-sing-3AN).

4. The noun mālsōnaw 'white maple' (pl. mālsōnāw-ək) and a few others must be marked as exceptions to this rule.

5. The suffix /-w/ is followed by /o/ before tense/aspect suffixes, including the preterite ending /-hp n/: māni-m-i-w-əhpən 'he had money.' It seems likely, however, that this /o/ either belongs to (an allomorph of) the following suffix or is epenthetic.

6. I frequently transcribed non-third person negative forms in -w with the grave accent on the final syllable in my early work on Passamaquoddy, but I am now convinced that these transcriptions are in error. There sometimes seems to be a slight rise in pitch associated with final Vw sequences in such forms, but the rising intonation of final syllables in third person forms is much more pronounced.

7. I am assuming that the third person suffix /-w/ precedes the negative /-wi/ in underlying forms and is deleted in this environment by a morphologically governed rule. If we supposed instead that /-w/ follows /-wi/, we could attribute the retention of the final vowel of this morpheme to the blocking effect of a final glide. If this analysis were correct, however, we would either expect /i/ to be retained obligatorily, as it is in nouns whose stems end in /iw/, or expect the third person suffix to be retained, as it is after stem-final /i/ in verbs.

8. We cannot rely on Schwa Support to introduce the necessary slot. The reduction of final /əw/ to o in əmocalo shows that Schwa Rounding (rule (34) of Chapter 3) has applied in the derivation of this form; but only schwas which are linked to

V-slots prior to the application of Schwa Support undergo Schwa Rounding. Thus the /ə/ of underlying /amocaləwe/ must receive a V-slot by some other rule. (See 4.6 for some discussion of the process by which final /əw/ surfaces as o.)

9. Sherwood (1983b:273-274) in fact postulates /ə/ as the underlying form of these suffixes, but explicitly notes the arbitrariness of this choice. The Proto-Eastern Algonquian antecedents of Conjunct perfective and subjunctive forms ended in \*e.

10. The literal meaning must be something like "the way I dress." Cf. ahāhs él-séwe-t (horse thus-dress-3AN) 'the way a horse is dressed' = 'harness.'

## BIBLIOGRAPHY

- Alger, Abby Langdon. (1885) "A Collection of Words and Phrases taken from the Passamaquoddy Tongue," Proceedings of the American Philosophical Society 22, 240-255.
- Barratt, Joseph. (1850) Key to the Indian Language of New England, in the Etchemin, or Passamaquoddy Language, Spoken in Maine and St. Johns New Brunswick. Middletown, Connecticut: Charles H. Pelton.
- Bochner, Harry. (1988) The Form of Words: A Theory of Lexical Relationships. Doctoral dissertation, Harvard University, Cambridge, Massachusetts.
- Bloomfield, Leonard. (1946) "Algonquian," in Harry Hojier, et. al., Linguistic Structures of Native America, pp. 85-129. Viking Fund Publications in Anthropology 6. New York: Wenner-Gren Foundation for Anthropological Research.
- (1958) Eastern Ojibwa: Grammatical Sketch, Texts, and Word List. Charles F. Hockett, ed. Ann Arbor: University of Michigan Press.
- (1962) The Menomini Language. Charles F. Hockett, ed. New Haven, Yale University Press.
- Chamberlain, Montague. (1899) Maliseet Vocabulary. Cambridge, Massachusetts: Harvard Coöperative Society.
- Clements, George N. (1985) "The Geometry of Distinctive Features," Phonology Yearbook 2, 225-252.
- Clements, George N. and Samuel Jay Keyser. (1983) CV Phonology: A Generative Theory of the Syllable. Cambridge, Massachusetts: MIT Press.
- Ford, Alan. (1983) "Une analyse autosegmentale de quelques alternances morphologiques du cris-montagnais," in William Cowan, ed., Actes du Quatorzième Congrès des Algonquistes, pp. 293-300. Ottawa: Carleton University.
- Goddard, Ives. (1969) Delaware Verbal Morphology: A Descriptive and Comparative Study. Doctoral dissertation, Harvard University, Cambridge, Massachusetts.



- . (1970) "Preliminary Informal Statement on Malecite Prosodics," mimeo. Cambridge, Massachusetts: Department of Linguistics, Harvard University.
- . (1979a) "Comparative Algonquian," in L. Campbell and M. Mithun, eds., The Languages of Native America: Historical and Comparative Assessment, pp. 70-132. Austin, Texas: University of Texas Press.
- . (1979b) Delaware Verbal Morphology: A Descriptive and Comparative Study. New York: Garland. [Published version of Goddard (1969).]
- . (1980) "Eastern Algonquian as a Genetic Subgroup," in William Cowan, ed., Papers of the Eleventh Algonquian Conference, pp. 143-158. Ottawa: Carleton University.
- . (1982) "The Historical Phonology of Munsee," IJAL 48, 16-48.
- Goddard, Ives, C.F. Hockett, and Karl Teeter. (1972) "Some Errata in Bloomfield's Menomini," IJAL 38, 1-5.
- Haas, Mary R. (1936) [Passamaquoddy and Penobscot field notes], ms.
- Halle, Morris and Jean-Roger Vergnaud. (1984) [No title], ms., Department of Linguistics, MIT, Cambridge, Massachusetts.
- Harris James. (1983) Syllable Structure and Stress in Spanish: A Nonlinear Analysis. Cambridge, Massachusetts: MIT Press.
- Hayes, Bruce (1980). A Metrical Theory of Stress Rules. Doctoral dissertation, MIT, Cambridge, Massachusetts.
- . (1982) "Extrametricity and English Stress," Linguistic Inquiry 13, 227-276.
- . (1984) "Inalterability in CV Phonology," paper presented at the Fourteenth Annual Meeting of the North Eastern Linguistic Society.
- . (1986a) "Assimilation as Spreading in Toba Batak," Linguistic Inquiry 17, 467-497.
- . (1986b) "Inalterability in CV Phonology," Language 62, 321-351.
- Hayes, Bruce and Stanisław Puppel. (1985) "On the Rhythm Rule in Polish," in Harry van der Hulst and Norval Smith, eds., Advances in Nonlinear Phonology. Dordrecht: Foris.
- Hockett, Charles F. (1957) "Central Algonquian Vocabulary: Stems in /k-/, " IJAL 23, 247-268.

- Kenstowicz, Michael and Charles Pyle. (1973) "On the Phonological Integrity of Geminate Clusters," in Michael J. Kenstowicz and Charles W. Kisseberth, eds., Issues in Phonological Theory: Proceedings of the Urbana Conference on Phonology, pp. 27-43. The Hague: Mouton.
- Leavitt, Robert M. (1985) "Passamaquoddy-Malecite Preverbs," in William Cowan, ed., Papers of the Sixteenth Algonquian Conference, pp. 73-90. Ottawa: Carleton University.
- Leavitt, Robert M. and David A. Francis. (1983) Passamaquoddy-Maliseet Verb Paradigms. Fredericton, New Brunswick: Micmac-Maliseet Institute.
- (1984) Passamaquoddy-Maliseet Verb Paradigms, second edition. Fredericton, New Brunswick: Micmac-Maliseet Institute.
- Leavitt, Robert M. and David Francis, eds. (1984) Kolusuwaklonol: Peskotomuhkati-Wolastogewi naka Ikolisomani Latuwewakon/ Philip S. LeSourd's English and Passamaquoddy-Maliseet Dictionary. Fredericton, New Brunswick: Micmac-Maliseet Institute.
- Leavitt, Robert M. et al. (1986) Nihtawewest/I Know How to Speak. Fredericton, New Brunswick: Micmac-Maliseet Institute.
- LeSourd, Philip S. (1979) Preliminary Passamaquoddy Dictionary. Xerox distributed by the Wabnaki Bilingual Education Program, Calais, ME.
- (1982) "An Accentual Problem in a Maliseet Dialect," ms.
- Liberman, Mark and Alan Prince. (1977) "On Stress and Linguistic Rhythm," Linguistic Inquiry 8, 249-336.
- Michelson, Karin. (1986) "Invisibility: vowels without a timing slot in Mohawk," ms., Department of Linguistics, Harvard University, Cambridge, Massachusetts.
- Mikcic/Turtle. Indian Township, Maine: Wabnaki Bilingual Education Program, 1976.
- Miner, Kenneth L. (1981) "Bloomfield's Process Phonology and Kiparsky's Opacity," IJAL 47, 310-322.
- Prince, Alan S. (1983) "Relating to the Grid," Linguistic Inquiry 14, 19-100.
- Prince, Henry. (1854) [Passamaquoddy vocabulary], ms., Smithsonian Institution, Washington, D.C.
- Prince, J. Dyneley. (1897) "The Passamaquoddy Wampum Records," Proceedings of the American Philosophical Society 36, 479-495.

- (1914) "The Morphology of the Passamaquoddy Language of Maine," Proceedings of the American Philosophical Society 53, 92-117.
- (1917) "A Passamaquoddy Tobacco Famine," IJAL 1, 58-63.
- (1921) Passamaquoddy Texts. Publications of the American Ethnological Society 10. New York, Berlin, and Leipzig.
- Schein, Barry and Donca Steriade. (1986) "On Gemimates," Linguistic Inquiry 17, 691-744.
- Selkirk, Elisabeth O. (1984) Phonology and Syntax: The Relation between Sound and Structure. Cambridge, Massachusetts: MIT Press.
- Sherwood, David F. (1983a) "Maliseet Verbs of Possession," Linguistic Inquiry 14, 351-356.
- (1983b) Maliseet-Passamaquoddy Verb Morphology, doctoral dissertation, Yale University, 1983.
- (1986) Maliseet-Passamaquoddy Verb Morphology. Canadian Ethnology Service Paper no. 105. Ottawa: Canadian Museum of Civilization. [Published version of Sherwood (1983b).]
- Siebert. (1967) "The Original Home of the Proto-Algonquian People," in A.D. DeBlois, ed., Contributions to Anthropology: Linguistics I (Algonquian), pp. 13-47. Anthropological Series 78, National Museum of Canada Bulletin 214.
- Stowell, Tim. (1979) "Stress Systems of the World, Unite!" MIT Working papers in Linguistics 1, 51-76.
- Szabó, László. (1972a) "Malecite Prosodics," in André Rigault and René Charbonneau, eds., Proceedings of the 7th International Congress of Phonetic Sciences, Montreal 1971, pp. 1032-1034. The Hague: Mouton.
- (1972b) "Stress and Vowel Length in Malecite," Proceedings of the American Philosophical Society 116, 338-342.
- (1979) "Vowel Length in Micmac and Malecite," in Harry Hollien and Patricia Hollien, eds., Current Issues in the Phonetic Sciences 1, 583-587. Amsterdam: John Benjamins.
- (1981) Indianisches Wörterbuch. Malecite-Deutsch-Englisch. Wiesbaden: Otto Harrassowitz.
- Teeter, Karl V. (1967) "Preliminary Report on Malecite-Passamaquoddy," in A.D. DeBlois, ed., Contributions to Anthropology: Linguistics I (Algonquian), pp. 157-162. Anthropological Series 78, National Museum of Canada Bulletin 214.

- (1971) "The Main Features of Malecite-Passamaquoddy Grammar," in Jesse Sawyer, ed., Studies in American Indian Languages, pp. 191-249. University of California Publications in Linguistics 65. Berkeley and Los Angeles: University of California Press.
- (1978) "Malecite-Passamaquoddy Educational Materials," Algonquian Linguistics 4(2), 4-6.
- Teeter, Karl V. and Philip LeSourd. (1983) "Vowel Length in Malecite," in William Cowan, ed., Actes du Quatorzieme Congrès des Algonquistes, pp. 245-248. Ottawa: Carleton University.
- Warne, Janet L. (1977a) "A Historical Phonology of Malecite," ms., Department of Linguistics, McGill University, Montreal.
- (1977b) "The Genetic Relationship of Abenaki, Penobscot, and Malecite," ms., Department of Linguistics, McGill University, Montreal.