

The Logical Form of Quantification and Plurality
in Natural Language

by

Brendan Stormont Gillon

B.A. The University of Michigan (1971)

M.A. The University of Michigan (1976)

M.A. University of Toronto (1978)

SUBMITTED TO THE DEPARTMENT OF
LINGUISTICS AND PHILOSOPHY
IN PARTIAL FULFILLMENT OF THE
REQUIREMENTS OF THE
DEGREE OF

DOCTOR OF PHILOSOPHY IN
PHILOSOPHY

at the

MASSACHUSETTS INSTITUTE OF TECHNOLOGY

June 1984

© Brendan Stormont Gillon 1984

The author hereby grants to M.I.T. permission to reproduce and
to distribute copies of this thesis document in whole or in part.

Signature of Author

Department of Linguistics and Philosophy
June 15, 1984

Certified by

_____)
James Higginbotham
Thesis Supervisor

Accepted by

Richard Cartwright
Chairman, Departmental Committee on Graduate Studies

ARCHIVES
MASSACHUSETTS INSTITUTE
OF TECHNOLOGY

JUN 26 1984

LIBRARIES

THE LOGICAL FORM OF QUANTIFICATION AND PLURALITY
IN NATURAL LANGUAGE

by

Brendan Stormont Gillon

Submitted to the Department of Linguistics and Philosophy
on June 15, 1984, in partial fulfillment of the requirements
for the Degree of Doctor of Philosophy in Philosophy

ABSTRACT

The thesis is concerned with the logical form of sentences of natural language, in particular, with how quantificational aspects of sentences in natural language are to be represented in a theory of grammar. The question is explored with respect to a circumscribed, but interesting, class of sentences. The theory of grammar within which the question is pursued is a version of Chomsky's theory of government and binding, as extended in recent work by Higginbotham. An especially important feature of the theory for the question treated is that syntactic and semantic principles are formulated in autonomous terms.

In the first chapter, the theory of grammar adopted for the analysis is outlined. A class of sentences, called "simple sentences", is defined on a purely syntactic basis in the second chapter. Established in the course of defining this class is the fact that cardinal numerals are adjectives and not determiners (and hence, not quantifiers). The third chapter contains the semantic principles governing the interpretation of lexical items occurring in simple sentences. This leads, in the fourth chapter, to a statement of the recursive principles of interpretation for simple sentences. Included here is also a treatment of the semantics of the collective and distributive readings of plural noun phrases. This treatment elaborates earlier work by Higginbotham, drawing on data and insights from Langendoen and L. Carlson. The upshot is that an array of data, previously seemingly heterogeneous, is brought within the purview of a few simple principles, formulated in terms of the notion of a plurality cover, a kind of cover only slightly richer than a partition. In the fifth chapter, the previous analysis is extended to a still larger class of sentences, which contain so-called "floated quantifiers", adjectival phrases, and prepositional phrases. This extension affords, in the sixth chapter, an analysis of sentences, which requires no such complication. Finally, in the conclusion, it is observed that for the class of sentences examined in the thesis, nothing more elaborate than standard restricted quantifiers is required to represent their quantificational aspects; in fact, it turns out, were higher order quantifiers adopted, as suggested by Langendoen and L. Carlson, to capture the semantics of plural noun phrases, or branching quantifiers, as suggested by Hintikka, to capture

the alleged semantics of certain complex sentences, essential syntactic and semantic insights, which are independently grounded, would be jeopardized.

Thesis Supervisor: James Higginbotham
Title: Associate Professor of Linguistics
and Philosophy

To the memory of
my brother Bob

ACKNOWLEDGEMENTS

The completion of my doctoral dissertation affords me a greatly welcomed occasion to express my gratitude to a number of people who have assisted me, both directly and indirectly, in my pursuit of it. Obviously, I have received great assistance from my thesis committee, Sylvain Bromberger and Noam Chomsky, as well as my thesis advisor, Jim Higginbotham. Not at all obvious, but just as great, is the help I have derived from my friend Rick Lathrop. Over the last three years, he has spent many hours explaining concepts in mathematics and computer science pertinent to my philosophic and linguistic interests; more recently, he has spent much time going over my dissertation elucidating its mathematical and computational implications and identifying many errors, big and small.

An early version of the thesis was presented in a series of four colloquia to the University of Alberta Logical Grammar Study Group (attended by Matthew Dryer, David Justice, Bernard Linsky, Francis Jeffry Pelletier, and Lenhart Schubert). Their discussion and criticism secured a number of improvements in the thesis, which would not have been realized otherwise. I have also benefitted from a number of discussions of both a philosophic and linguistic nature which I have had with Peter Ludlow.

My own linguistic skills would be far duller and more parochial had it not been for my collaboration with Richard Hayes in work on Sanskrit during the last many years.

In addition to the intellectual assistance leading up to and including my thesis, I have been greatly helped intellectually and personally by: Ursula Franklin, Cathy Jenner, David Rayside, Dan Romanow, and of course Reed Slatkin -- all my friends in need.

The thesis would never have got into the form I wanted it in, had it not been for Maggie Carracino. She has been most generous with her time and most patient with my fussiness.

Finally, nothing I have ever done would have been possible without my parents who have done so much for me.

TABLE OF CONTENTS

INTRODUCTION	8
CHAPTER ONE: THE THEORY OF GRAMMAR AND LOGICAL FORM	15
1.0 Introduction	
1.1 The Linguistic Framework	
1.2 The Theory of Universal Grammar	
1.2.1 DS to SS	
1.2.2 SS and Conditions on SS	
1.2.3 LF and Conditions on LF	
1.3 Conclusion	
CHAPTER TWO: THE SYNTAX OF SIMPLE SENTENCES	56
2.0 Introduction	
2.1 The Simple Noun Phrase: Syntax	
2.1.1 The Syntactic Taxonomy of Determiners	
2.1.2 The Syntactic Taxonomy of Nouns	
2.1.3 Syntactic Features and the Noun Phrase	
CHAPTER THREE: THE SEMANTICS OF LEXICAL ITEMS	84
3.0 Introduction	
3.1 Determiners Interpreted	
3.1.1 Demonstratives Interpreted	
3.1.2 Quantifiers Interpreted	
3.2 Nouns Interpreted	
3.2.1 Count Nouns and Proper Names Interpreted	
3.2.2 Pronouns Interpreted	
3.3 Verbs Interpreted	
3.4 Conclusion	
CHAPTER FOUR: THE SEMANTICS OF SIMPLE SENTENCES	114
4.0 Introduction	
4.1.1 Miscellaneous Principles of Interpretation	
4.1.2 Simple Noun Phrases Interpreted	
4.2 Collective and Distributive Readings	
4.3 Simple Sentences Interpreted	
4.3.1 Simple Sentences with Reciprocal Pronouns Interpreted	
CHAPTER FIVE: THE SEMANTICS OF LESS SIMPLE SENTENCES	153
5.0 Introduction	
5.1 Q-Float	
5.2 The Noun Phrase Revisited	
5.2.1 Simple Noun Phrases with Prenominal Adjectives	
5.2.2 Simple Noun Phrases with Prepositional Phrases	
5.3 Conclusion	

CHAPTER SIX: HINTIKKA AND BRANCHING QUANTIFIERS

193

- 6.0 Introduction
- 6.1 The Theory fo Branching Quantifiers
- 6.2 Branching Quantifiers and Simple Sentences
- 6.3.1 A Case for Branching Quantifiers
- 6.3.2 Another Case for Branching Quantifiers
- 6.4 Conclusion

CONCLUSION

226

INTRODUCTION

What is the logical form of sentences of natural language? This question, first raised almost a century ago, has come to the fore of philosophic and linguistic debate. Nothing like a definitive answer is even in sight. Indeed, if the current perception of the complexity of natural language is a guide, it will be a long time coming.

Attention of those interested in the logical form of natural language's sentences has focussed, in recent years, on a more narrow, and perhaps more immediately tractable, question: how are quantificational aspects of sentences in natural language to be represented? The kinds of sentences looked at from this point of view are many, and the forms of representation proposed diverse. No one work could take in all of the data and all of the proposals bearing on the question. My aim is modest: I wish to answer this question for a small, but interesting, class of sentences. I intend to do so by setting out a comprehensive syntactic and semantic analysis for the sentences of this class. Thus, my proposal concerning the form of representation of the quantificational aspects of these sentences must ultimately be evaluated with respect to its place in more comprehensive theories whose outlines are now only dimly seen.

The analysis developed or adopted in this thesis differs in two major ways from some others aiming at the same or similar

ends. First, semantic and syntactic analyses are on an equal footing. In other words, the analysis does not regard the syntax as a trivial projection of the semantics or the semantics as a trivial projection of the syntax. Instead, they are viewed as autonomous systems which interact. Second, the semantic analysis of allegedly quantificational aspects of sentences resists the proliferation of quantifiers. The provenience of this resistance is not any a priori conviction banning from the forms of representation certain types of quantifiers, but rather an a priori principle requiring the best fit of the facts with the theory within whose confines the facts are being explored. As it turns out, representation of any of the sentences surveyed below by second order quantifiers or by branching quantifiers would seriously jeopardize well and independently grounded principles pertaining to the syntax and semantics of the sentences I am to treat. To show this, is what, among other things, this thesis will do. At the moment, I only limn the issues and foreshadow the results.

A central issue of this thesis is the proper treatment of the semantic properties of plural noun phrases. In much previous work on this issue, higher order quantification has been adopted as the appropriate form of their representation. Langendoen (1978) studies simple sentences with plural noun phrases and with

reciprocal and reflexive pronouns. He shows that no satisfactory treatment of their semantics can avoid sets in one form or another. More exactly, he shows that collective and distributive readings of plural noun phrases and the reciprocal relation (induced by the reciprocal pronoun on the verb of which it is an object) cannot be defined over individuals. His option is to appeal to hidden quantifiers of second order predicate logic. Lauri Carlson (1982) broadens the compass of data and refines the accuracy of the statement of the semantic facts. He too uses the quantifiers of second order predicate logic, but within the larger framework of game theoretic semantics. Drawing on the array of data and on the insights of these two treatments, I provide an alternative analysis which is an elaboration of a suggestion by Higginbotham (1981). He proposes that a plural noun phrase be interpreted as a set and that the collective and distributive readings to which it is liable depend on which subsets of the set interpreting it the predicate in question is true of. In pursuing his idea, I make explicit just what kind of subsets of a set interpreting a noun phrase is pertinent to the evaluation of the interpretation of its predicate: the family of these subsets is what I call a "plurality cover". The set of plurality covers of a given set is intermediate between the set of its covers and the set of its partitions. It forms a partial

order with a least and a greatest element.

There are several attractive features of this approach. First, it is a simple and comprehensive treatment of the collective and distributive readings of plural noun phrases and it dovetails nicely with already established semantic and syntactic principles. In particular, it retains Higginbotham's (1981) appealing principle for the interpretation of sentences with reciprocal pronouns, which retains the intuitive idea that a reciprocal relation holds of all distinct pairs of a set. Also, the facts pertaining to the interpretation of singular and plural quantified noun phrases fall to the same analysis, supplemented only by principles which are already established and independently grounded. Next, this treatment of plural noun phrases affords a way to overcome two anomalies resulting from taking cardinal numerals as quantifiers. The one is that phrases with cardinal numerals do not seem to obey principles governing the assignment of scope to quantifiers; that is to say, they are liable to more readings than there are available assignments of scope. The other is that cardinal numerals fail to pattern with the syntactic distribution of paradigmatic quantifiers. Finally, without any further elaboration of the syntactic representation upon which semantic interpretation is to be done, there is available a fully compositional implementation of all the

principles of interpretation adopted or developed in this thesis.

Another issue is one raised by Hintikka (1973). He has argued that there are sentences in natural language, in English specifically, which require branching quantifiers for their proper representation. At the time Hintikka argued for his claim, the syntax of the scope of quantifiers in natural language, and in English in particular, was just beginning to get sustained philosophic and linguistic scrutiny. Though considerable doubt has been cast on whether or not the sentences adduced by Hintikka mean what he says they mean (e.g., Fauconnier 1975), nonetheless no syntactic and semantic analysis of his sentences has been given. In part, this is because no systematic syntactic treatment of quantifiers and their scope had been given. This situation was changed by May (1977). In light of the rapidly accumulating analysis of both the syntax and semantics of quantifiers and their scope, the time is right for a re-assessment of Hintikka's claim and evidence. And it is to this re-assessment that I also turn. As it happens, the principles of this thesis vindicate the doubts raised against those of Hintikka's sentences which fall within the purview of this thesis.

Obviously, my treatment of the two issues stated above is not ab ovo. My point of departure is a version of Chomsky's theory of government and binding, more precisely, a version of the theory's development due to Higginbotham (1983). Those parts of the theory and Higginbotham's extensions of it which are germane to the task are outlined in the first chapter. The next major step is to define an interesting class of sentences, which I call "simple sentences", and to furnish them with a semantic analysis. The analysis includes all the principles needed for the interpretation of simple noun phrases, with their diversity of collective and distributive readings, in simple sentences. The syntax of simple sentences is set out in the second chapter; the principles for interpreting lexical items in most categories of lexical items which occur in these sentences is stated in the third chapter; and the principles for interpreting the simple sentences themselves are given in the fourth. In the fifth chapter, I extend the analysis to encompass a still larger class of sentences among which are to be found those of Hintikka. I confront, in the sixth chapter, Hintikka's claim and evidence, showing that his arguments do not sustain his claim and that his sentences yield to a well-grounded analysis which obviates their representation by branching quantifiers. Finally, I conclude by returning to my central claim, namely, that the proper semantic

representation for the class of sentences treated in this thesis requires neither second order nor branching quantifiers.

CHAPTER ONE

THE THEORY OF GRAMMAR AND LOGICAL FORM

1.0 Introduction

If it is tautological that a theory about natural language is a theory about natural language, and not a theory about, say, logic, then it should go without saying that standard logical notation when applied to natural language is not theoretically privileged. After all, syntax itself is a form of notation. Once this point is fixed in mind, there is no harm in using names of the structures of logic to identify analogous structures in language. And it is in this analogical sense that one can talk about operators and quantifiers, as well as their scopes, in natural language. I shall do so in what follows. Moreover, once one has so extended one's use of these terms commandeered from logic, there is no harm in availing oneself of them to suggest, through their analogy with elements of natural language, further analogies. But, in the end, it is the syntactic structures of language which constitute the object of study.

The central empirical problem of this thesis is to account for the quantificational aspects of certain sentences in terms of

their structure. Any such analysis presupposes a linguistic framework within which the analysis is to be carried out. This chapter will make available to the reader the necessary linguistic background.

Now while it is obvious that a treatment of the quantificational aspects of sentences of natural language requires that the pertinent linguistic details of the theory within which the treatment is being carried out be made explicit, it may not be obvious that the theory's very framework need be made explicit. But it does, and for two different sorts of reasons. The first is general. Different frameworks lead to different theories. This now commonplace observation among historians and philosophers of science, proves particularly pertinent when discussing issues and theories of a discipline where frameworks abound, such as linguistics, for in such disciplines, theories must be explicitly situated in their framework if they are to be understandable, let alone convincing, to those of a different persuasion. The second reason is more specific: part of the treatment of the problem addressed in the thesis involves a re-assessment of what counts as linguistic data in light of the basic framework. Thus, a discussion of the underlying linguistic framework of the thesis is indirectly required for a proper grasp of the grammatical theory within

which the problems addressed are tackled, and is directly required for the treatment itself to be understood.

1.1 The Linguistic Framework

The two central points to be understood about the linguistic framework adopted here are: what it takes its object of study to be and how it proposes to pursue the study of its object. The exposition must proceed first with an exposition of the object of study, and second with its pursuit.

It has been traditionally assumed that language is the proper object of linguistics. This is a natural assumption since utterances, which make up language, are immediate in our experience of the world. But, what is immediate in experience often is not what is fundamental in theory -- an observation made long ago by Aristotle (Physics Book I, Chapter 1, 184a 17ff.) and borne out in the development of the physical sciences since him. And it is a shift away from what is immediate in experience, namely the utterances of language, to what, it is thought, is fundamental in theory, namely, the human capacity to use language, which characterizes much of the work in linguistics after the heyday of structuralism, in particular, all of the work going under the name of "generative-transformational

linguistics." Since the linguistic framework adopted in this thesis is based on the view that the fundamental object of study in linguistics is the human capacity to use language, it is appropriate to set forth the basis of this view.

The question of how humans acquire their capacity to use language can be seen as an instance of a larger question. The larger question is this: if a mature organism has a capacity, which at its inception it cannot exercise and at a later time can, then how does it come to exercise this capacity? Thus, one might ask how cats come to hunt rodents, birds to make nests, or salmon to swim up river to spawn eggs? Clearly there are only two dimensions along which to search for pertinent facts: experience and innate structure. Equally clear is that facts along either dimension alone are not sufficient for answering this larger question. Experience by itself is not sufficient, for an organism which is not disposed to develop a capacity can never develop it. Cats do not build nests; birds do not swim up stream to spawn eggs. Also, innate structure by itself is not sufficient, for ex hypothesi the organism at inception cannot exercise the capacity. So, the question becomes: what balance between innate structure and experience is needed to bring about the organism's ability to exercise the capacity which it eventually acquires? For there to be an answer, two of three

parameters must be fixed. Therefore, in order to thus ascertain what the innate structure is, one is obliged to fix what the capacity is which the organism comes to exercise and what kind of experience is pertinent to that capacity. If one pursues this line of inquiry, then one might try to construct a device (like the one diagrammed below) to simulate this process.

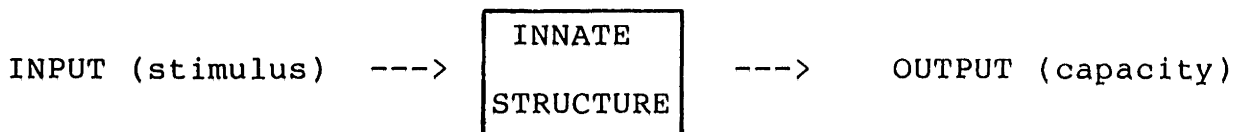

Figure 1

Assuming that humans acquire a capacity to use and understand language, one can put this problem into the next format:

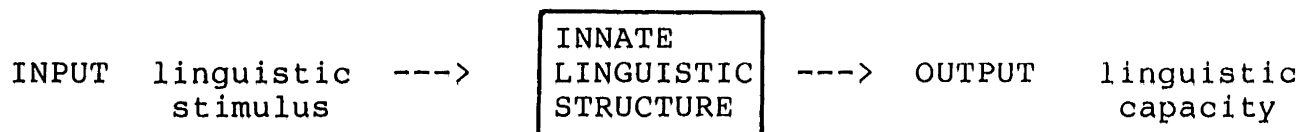

Figure 2

Thus framed, the problem poses two antecedent problems, in accordance with the more general framing laid out just above: to ascertain what experience is relevant to acquiring the use of language and to ascertain what the capacity attained is. The scope of the latter inquiry requires some elaboration of what a capacity is and how it relates to behavior.<l>

A capacity, so hypothesized, can be viewed as a system of subcapacities. Such a system, like the capacity itself, is an abstraction. One goes beyond abstraction as licensed by rational inquiry per se, when one addresses the question of what the sub-capacities are and how they are related to one another. The former question is an empirical one inasmuch as any answer to it must be subject to factual confirmation. The latter question is empirical too: the relationship among the subcapacities could be such that they cannot be characterized in independent terms, or it could be such that they can be. These alternatives are extremes of a gamut of possibilities. Which of these alternatives one is to select in formulating an initial hypothesis is a methodological question, the answer to which is obvious: in the absence of evidence to the contrary, assume the subcapacities to be completely autonomous from one another, that

is, the terms in which one is characterized are completely independent of those in which the others are characterized. Notice, however, to say that subcapacities are autonomous from one another is not to say that they do not interact! On the contrary, to say that the subcapacities are autonomous is to say that the complexity of behavior ascribed to the capacity in question can be factored into the contribution of interacting subcapacities, each based on principles, hopefully simple, which can be stated in their own independent terms.

All this applies to the human capacity to use and understand language. As was just shown, it is a routine matter of rational inquiry to regard this capacity as complex and to see it as abstractly constituted from subcapacities. It is usual to assume these subcapacities to include the capacity to remember, the capacity to form beliefs (doxic capacity), the capacity to conceive objects (conceptual capacity), and the capacity to form grammatical sentences (grammatical capacity). This factoring is, of course, an empirical hypothesis. Whether or not these capacities are autonomous from one another is a further empirical question. The starting point of generative linguistics has been not only that the grammatical capacity, so-called "Universal Grammar" (UG), is autonomous with respect to other capacities pertinent to the production and processing of the flow of speech,

but also that UG is itself a system of autonomous components, or modules.<2>

An especially important point arises from the foregoing for the treatment of the quantificational aspects of the sentences of natural language studied in this thesis. It is an implication concerning linguistic data on the one hand and the interaction of UG and the human doxic and conceptual capacities on the other. Primary linguistic data is assumed to consist of judgments by speakers of the deviance (or non-deviance) of expressions in their language. In light of the view which takes as its object the human capacity to use and understand language, the provenience of these judgments is not trivial to ascertain. That is, although judgments of deviance are certainly facts about the human capacity for language, nonetheless it need not be obvious to which sub-capacity these facts pertain. Deviance may reflect on syntax, semantics, or pragmatics, or it may not reflect on UG at all, but rather on the components whereby beliefs are formed and objects conceived. One of the results of this thesis is that many judgments of deviance with regard to sentences containing plural noun phrases have their basis, not in UG, but in the doxic and conceptual components.

Now, I stated above that the factoring of a capacity into a

system of autonomous sub-capacities (modules or components) is an empirical hypothesis. It is hard to imagine that one could question whether or not humans have a capacity to remember, to form beliefs, or to conceive of objects of certain kinds. Yet, it has been a matter of controversy whether or not humans have an autonomous capacity to form grammatical sentences. However, there are facts, which, when properly marshalled, make the existence of such an autonomous capacity nearly certain and also place significant constraints on any putative hypothesis of what the capacity is.

I shall now marshall these facts. First, no child is more disposed to learn one language rather than another. A child raised in a community where only Marathi is spoken will acquire competence in Marathi as quickly and as easily as he would Chinese, had he been raised in a community where only Chinese is spoken (all other things being equal). Secondly, the structure of a language, over which a child gains mastery, is both abstract from its acoustic signal and complex. This is illustrated by such sentences as

(1) The mother of the girl and the boy will leave.

It is in virtue of structure, constituent structure, that this

same string, when uttered, is liable to two distinct interpretations: namely, there is a mother of a girl and a boy and she will leave (compare: the mother of the girl and the boy is leaving); and there are a boy and a mother of a girl and they will leave (compare: the boy and the mother of the girl are leaving). Thirdly, whereas the structure of language is both abstract from its acoustic signal and complex, competence to use these structures is acquired by a child in a short span of time, through little exposure to signals carrying examples of the structure; and much of the information about the structure conveyed by the signals is deficient. In other words, many of these sentences to which the child is exposed are ill-formed: they are half-sentences, they are interrupted sentences, they are unfinished sentences. Moreover, the exposure the child has by the time he has acquired linguistic competence is rather impoverished, especially in view of the abstract nature of his competence. Finally, whereas the resulting competence is uniform across the community of speakers of which the child is a member, nonetheless his acquisition of that competence is independent of his intelligence, motivation, and emotional make-up.<3>

In light of these facts, the following limits are placed on any hypothesis about the innate structure by which humans acquire competence in their language. The innate structure cannot be so

rich as to predispose a child to acquire competence in one language over another. Nor can the innate structure be so poor as to fail to account for the rapid acquisition of competence by a child, given the abstract and uniform nature of the competence, the quality of his exposure, the poverty of his exposure, and the independence of his acquisition from his intelligence, motivation and emotional make-up. In short, this innate structure cannot be so rich as to preclude the acquisition of some attested language but it must be rich enough to ensure that one can acquire any attested language within the limits of time, data, and access to data.

Of course, those facts do not determine a unique hypothesis of UG, they only place constraints on possible hypotheses. Indeed, over the years there has been a succession of theories of UG. This succession has been marked by the further factoring of UG into autonomous sub-components or modules, which, in turn, has enriched the empirical basis of the theory. I now turn to the version of UG adopted here.

1.2 The Theory of Universal Grammar

The view adopted here is, in broad outline, a version of the extended standard theory found in Lectures on Government and

Binding (Chomsky 1981). Below, I shall limit enough of that view to permit me to undertake my task. What is sketched is not complete. Details are omitted, because they are irrelevant here; or they are postponed to later in the thesis, because they can be more succinctly and aptly stated there. Moreover, some of what is said here will be modified later; such things are simplifying assumptions aimed at helping one eschew unnecessary prolixity and complexity at an early stage of exposition. Finally, what is now set out is assumed; many arguments for this view are found elsewhere and need not be repeated here.

The theory of syntax adopted here gives the theory of universal grammar (UG) the first place of importance. UG, in this view, consists in a finite set of universal principles, or schemata, and finite sets of parameters, each associated with a universal principle. It is these principles and parameters which constitute the natural and initial human linguistic endowment. Instantiation of a universal principle, or schema, with values drawn from its associated set of parameters yields a particular principle. An instantiation of all the principles of UG yields a core grammar, that is, the grammar of a possible human language. Thus, the acquisition of linguistic competence is the instantiation of the principles of UG, which is done on the basis of information from the environment. Finally, what is generated

from a core grammar, the so-called "unmarked case", is to be distinguished from idiosyncracies, the so-called "marked case".

The actual structure of UG is conceived to be made up of a number of components, as represented below.

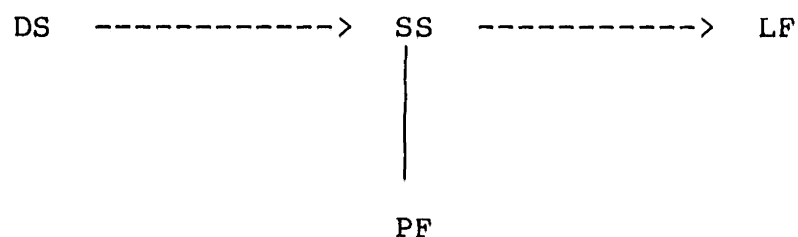

Figure 3

The lexicon, as the word suggests, is a dictionary: it provides the lexical building blocks of sentences. Associated with each lexical item is an entry specifying a phonological matrix, a categorial label (i.e., whether the item is a noun, verb, adjective, preposition, etc.), a subcategorization frame, argument structure, thematic roles, as well as idiosyncracies of the item (e.g., the plural form of medium is media). To say that the lexicon is the repository of lexical idiosyncracies does not mean that it is not governed by systematic principles; to the contrary, recent research shows that it is. But pursuit of this is out of place here. DS (alias, Deep Structure) provides some

of the structures into which the constituents of a sentence can be organized. Each such structure can be represented by a phrase marker. These structures are specified in accordance with X-Theory. Again, since these details of LGB are not required for the analysis of the kinds of sentences treated in this thesis, I omit further discussion of it and refer the reader to the relevant literature (Jackendoff 1977a, 1977b). Now, the lexicon is related to the constituent structure provided by DS through so-called lexical insertion: the free assignment of lexical items to a phrase marker under the proviso that the specifications of the lexical item's entry be compatible with the categorial environment of the phrase marker. Next, SS (alias, Surface Structure) is obtained from DS by so-called movement rules. A movement rule is essentially an amalgam of three basic operations performed on a phrase marker: erase, write, and adjoin. Notice that on this view, substitution is an amalgam of erase and write. The schema from which particular movement rules are obtained is: $\text{move } \alpha$. For a particular language and a particular, α takes on a value from the syntactic categories. In English, α can be either a noun phrase (NP) or any phrase containing "+WH" formative, in the case of the mapping from DS to SS. In the case of the mapping from SS to LF in English, α takes on the value of Q (the category: quantifier). In PF (Phonetic

Form) one obtains the final phonetic representation of the grammar. This component of the grammar is not germane here and it will not be discussed. LF (Logical Form) is obtained from SS, again by movement rules, and will be discussed in much detail below, as will be SS.

1.2.1 DS to SS<4>

Let me return to those parts of UG which are germane to the topic of this thesis. I begin with the theory of the mapping from DS to SS. When α takes on the value of NP, the movement can be seen to consist of two substitutions: an empty element for a non-empty element, and the non-empty element for another empty one (in accordance with specific constraints). The realization of the basic passive structure is an example of NP movement in English. Consider a phrase marker, like the following, in DS:

(2)

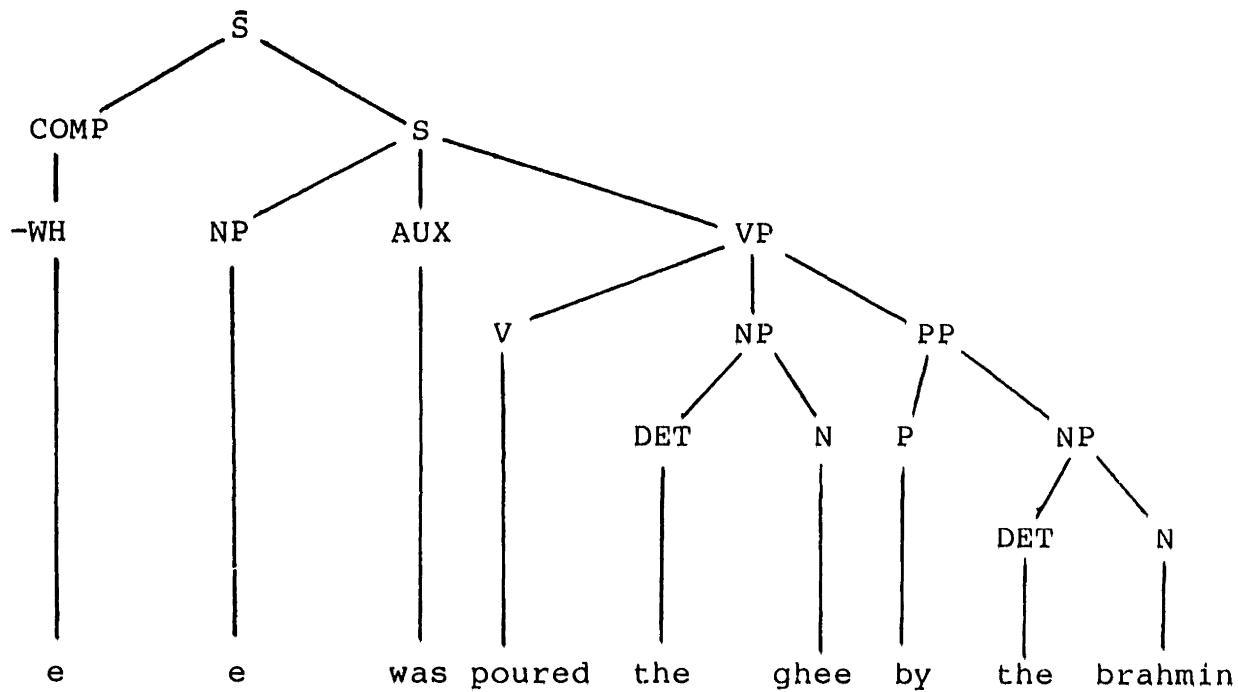

The element below

(3)



replaces a subtree from the DS phrase marker, namely,

(4)

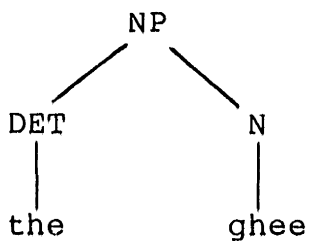

to yield

(5)

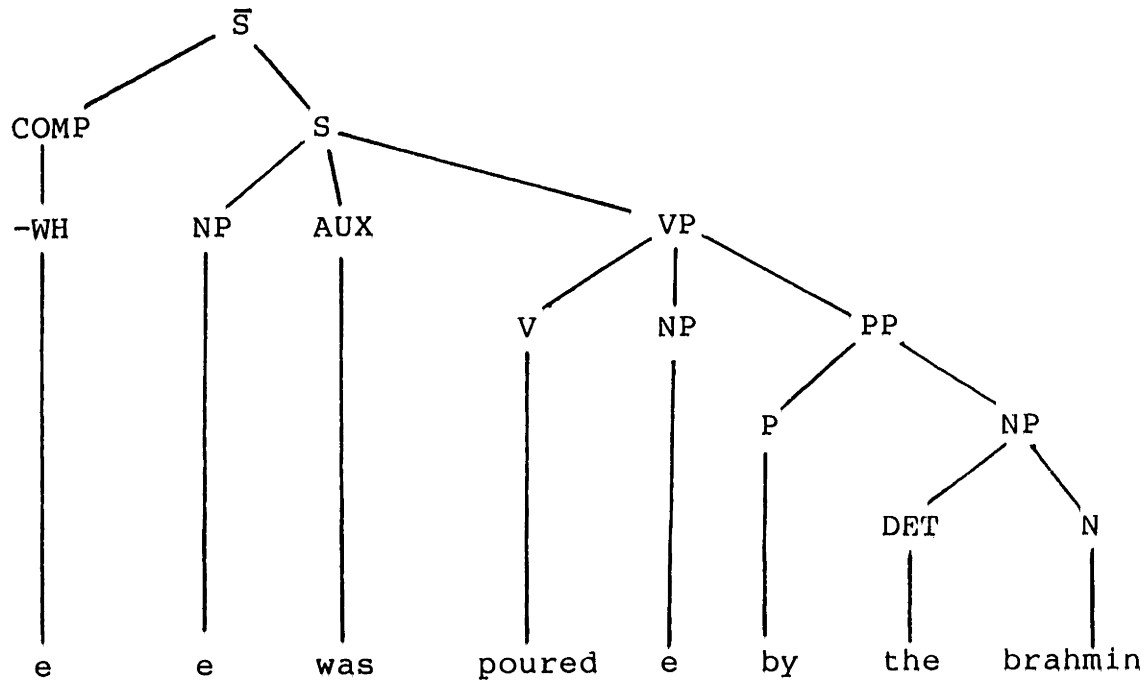

The element replaced, namely (4), now replaces the subtree in the phrasemarker which is of the same form as (3) to yield

(6)

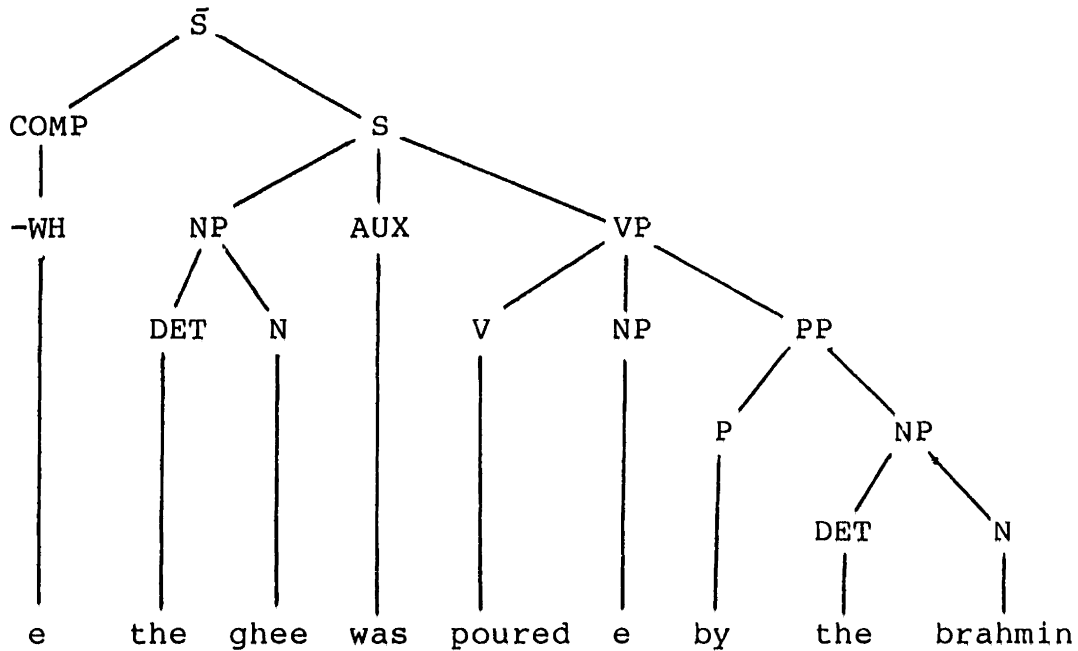

When α takes the value of +WH, there are two cases to be treated: one when +WH is an interrogative pronoun, and one when it is an interrogative adjective, to use traditional terminology. To see how this works, consider this phrase marker in DS which contains an interrogative pronoun:

(7)

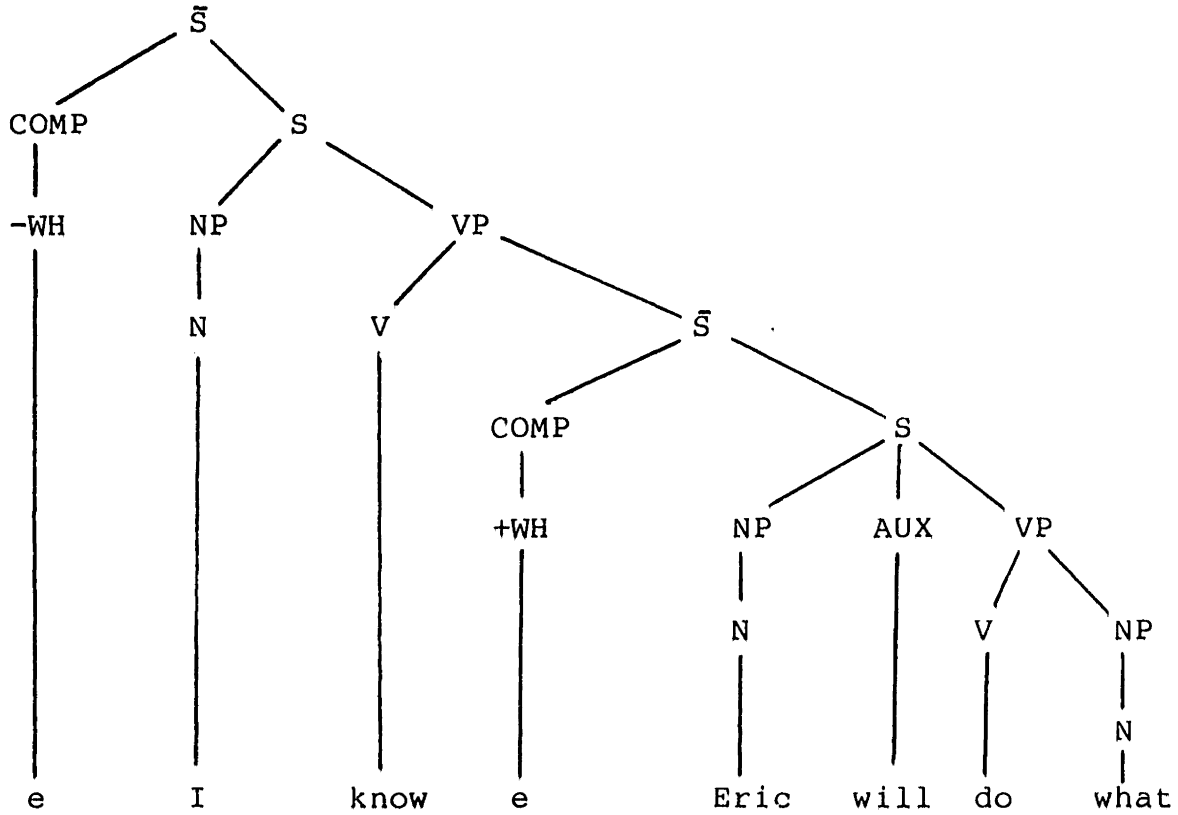

As before, there is a double substitution. An element of the form of (3) substitutes for the subtree in (7), namely,

(8)

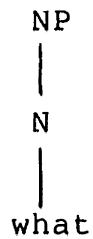

And it, in turn, substitutes for the subtree in (7), namely,

(9)



to yield the following element of SS:

(10)

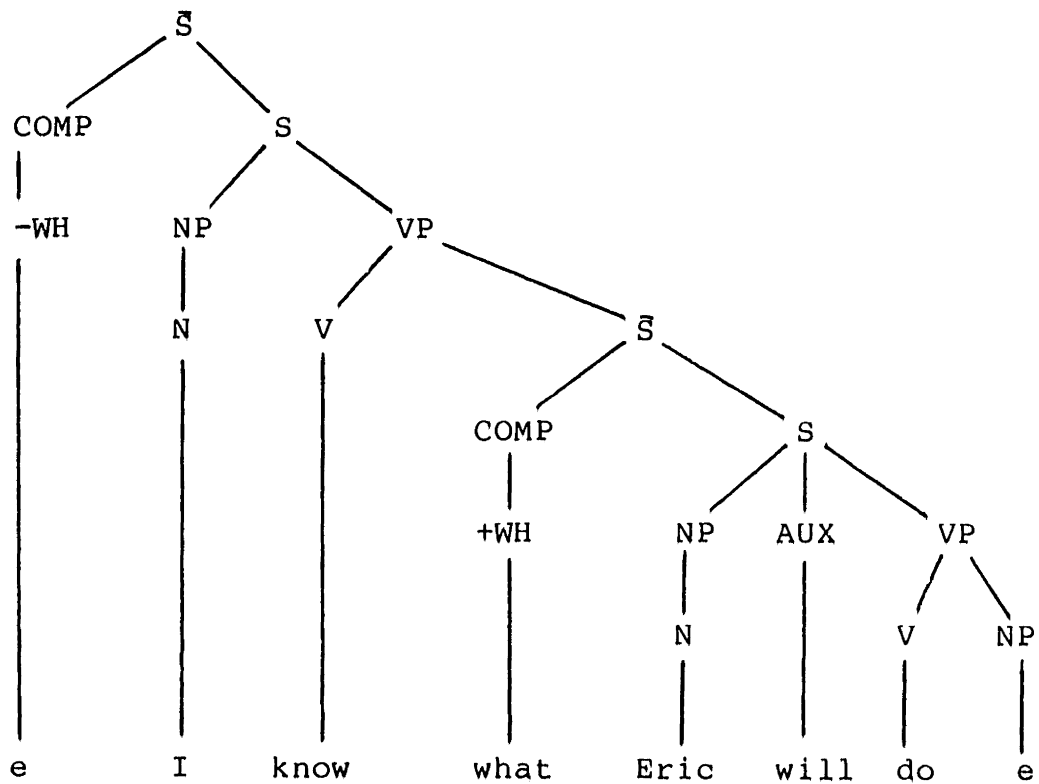

Second, consider the case where the phrase marker in DS contains an interrogative adjective instead.

(11)

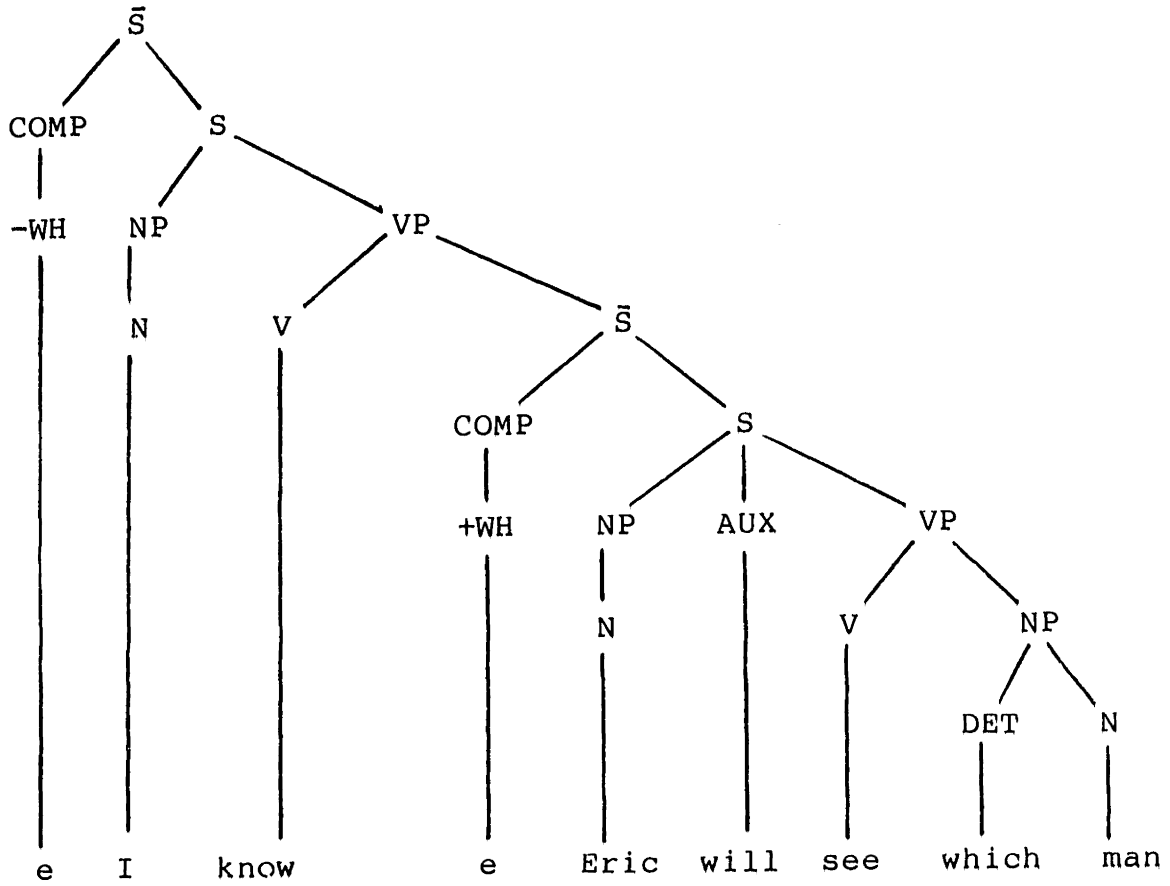

It yields this:

(12)

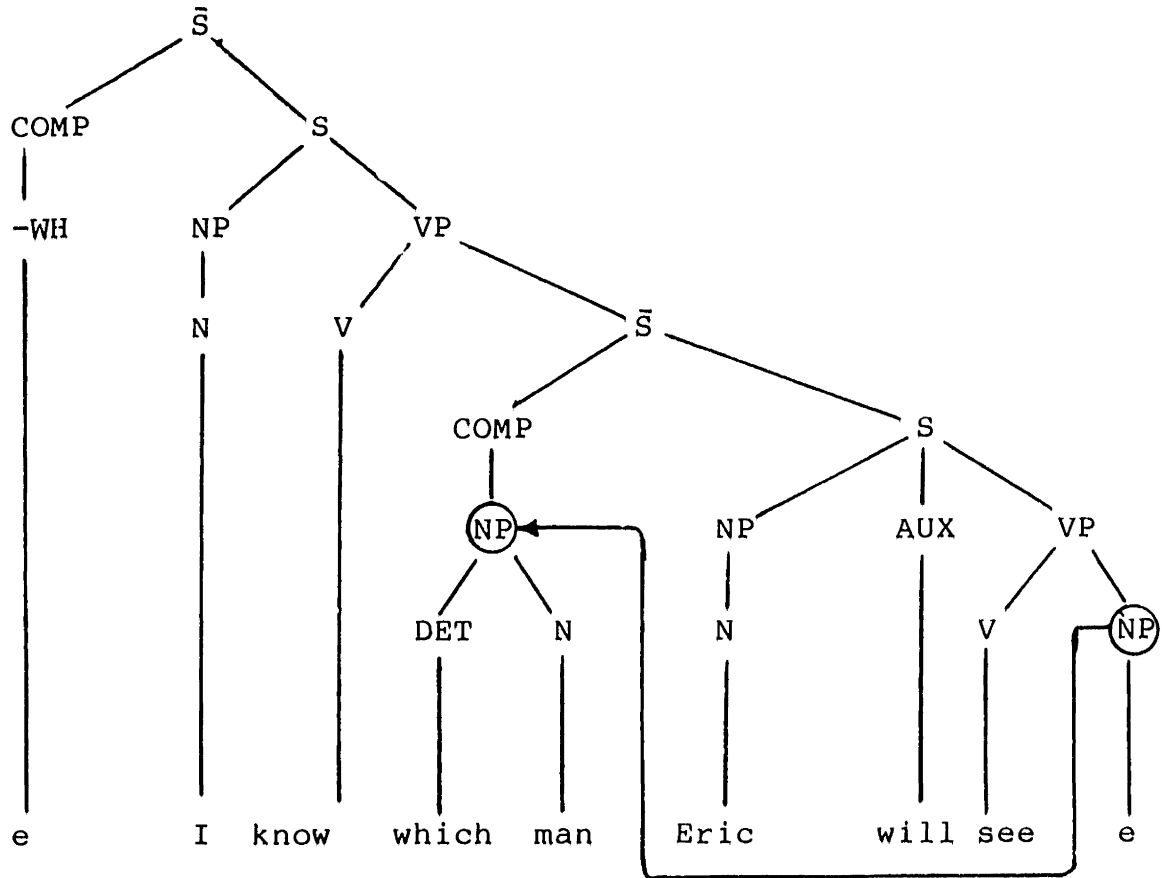

Notice that what has been moved is not the subtree

(13)



but rather a subtree containing (13), namely,

(14)

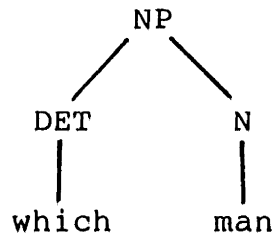

This results from the formulation of the rule of move where what triggers the movement is the +WH formative but what must be moved is the first phrase containing it, in this case, the noun phrase "which man".

1.2.2 SS and Conditions on SS<5>

Notice that in the representation of the phrase marker (12), there is, in addition to the lines indicating the dominance relation, a directed arrow linking the node from which the movement took place to the node to which the movement took place. This is not only a notational convenience permitting one to collapse a pair of phrase markers, connected through movement, into one, but it also forms the basis for representing a relation which is defined over argument positions in a phrase marker of SS. This relation, called "linking", is a binary, asymmetric (and hence, irreflexive) relation<6> permitted between any two argument positions in a phrase marker at SS. However, such a

relation must contain, in addition, all pairs of nodes paired through movement from DS to SS. Thus, one may represent this relation by arrows freely assigned to argument positions in the SS phrase marker; if the phrase marker in question is the output of a non-vacuous application of move α , applied to an element of DS, there will be, in addition, links created by the movement. The point is perhaps best seen when illustrated.

(15)

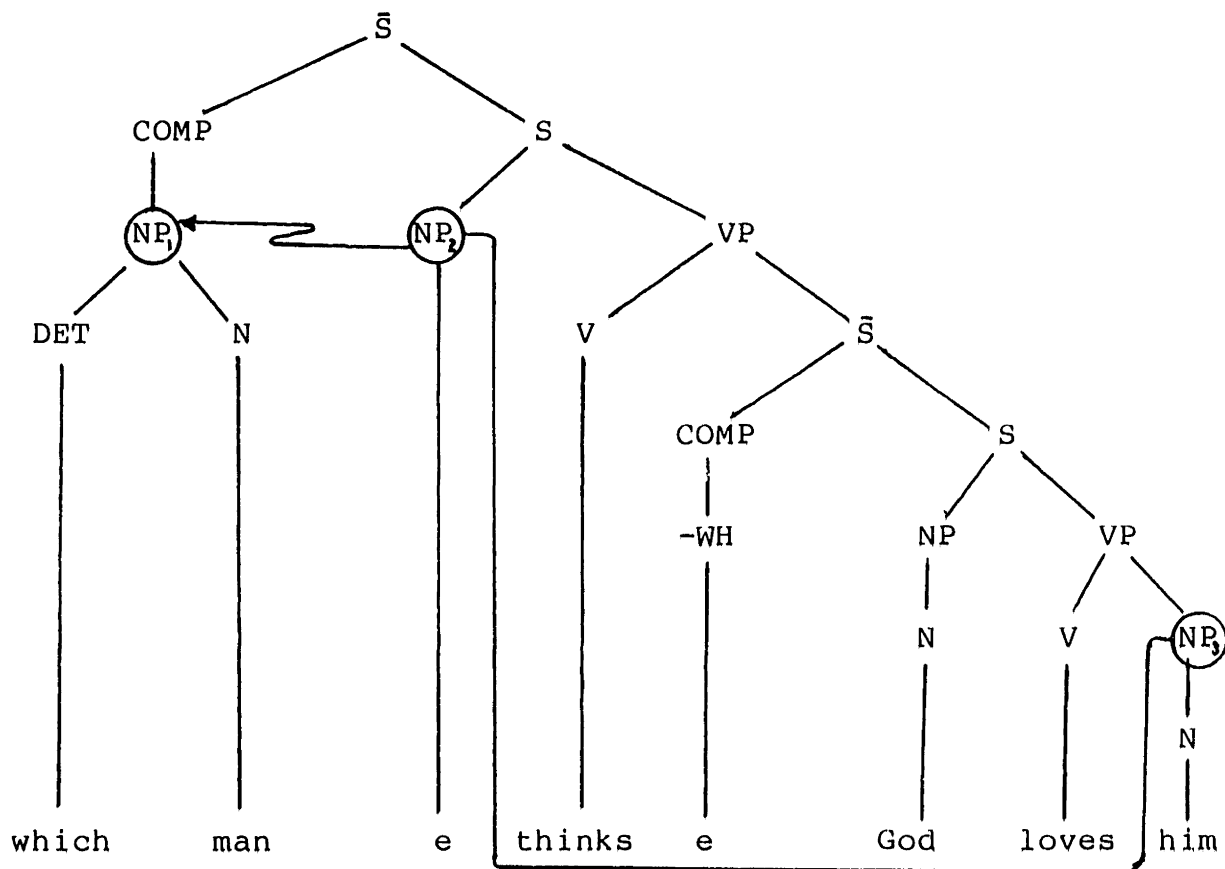

The link of NP_2 to NP_1 results automatically from movement; whereas the link of NP_3 to NP_2 results from the application of a

rule: link. The relation of antecedence is now defined by the relation of linking.

(16) Definition of the Relation of Antecedence

x is an antecedent of y if and only if (1) y is linked to x or (2) there is a z such that y is linked to z and x is an antecedent of z.

Thus, in (15), NP is an antecedent of NP since NP is linked to NP and NP is an antecedent of NP (since NP is linked to NP). In short, the relation of antecedence is the transitive closure of the relation of linking.

Whereas the relation of linking is freely created between argument positions in a phrase marker at SS, the relation of antecedence is subject to a certain constraint:

(17) Condition on Antecedence

If x c-commands y, then y is not an antecedent of x.

C-command is a relation between nodes in a phrase marker. It is an irreflexive relation and it obtains between a node and any of the nodes dominated by the first branching node dominating the node in question. In other words,

(18) Definition of the Relation of C-command<7>

x c-commands y if and only if (1) $x \neq y$,
(2) neither x nor y dominates the other, and
(3) there is a branching node z different from
 x and y which is the first branching node dominating
 x also dominating y .

In (15), NP_1 c-commands NP_2 and NP_3 ; NP_2 c-commands NP_3 . But NP_2 does not c-command NP_1 and NP_3 does not c-command either NP_1 or NP_2 . The upshot of this for the antecedence relation is that while linking permits NP_2 to be linked to NP_1 , NP_3 could not be the antecedent of NP_2 since NP_2 c-commands NP_3 , which violates (16).

Besides antecedence, there is another relation germane to the main issue of the thesis and to the exposition at hand, namely, the relation of dependence. It is defined in terms of the relation of antecedence and dominance.

(19) Definition of the Relation of Dependence

x depends on y if and only if (1) y is
dominated by an antecedent of x or (2) there
is a z such that x depends on z and z depends on y .

In other words, the relation of dependence is the transitive closure of the relation of being dominated by an antecedent. Applying this definition to the example below, one sees that "his" depends on "Joan".

(20)

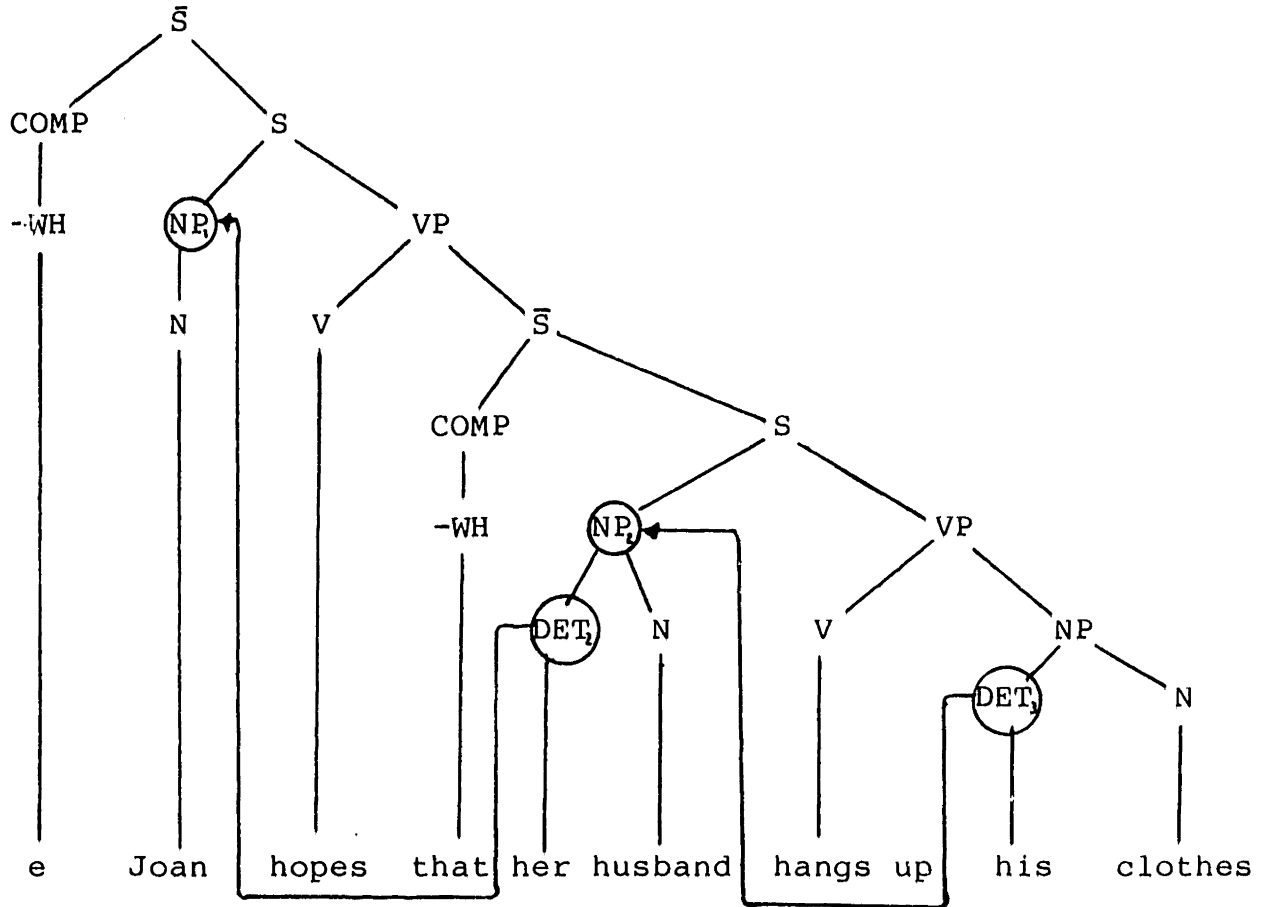

NP_2 is the antecedent of DET_3 , hence DET_3 depends on NP_2 . NP_2 dominates DET_2 . And so DET_3 depends on DET_2 . NP_1 , in turn, is an antecedent of DET_2 , so DET_3 depends on NP_1 .

Now, in terms of this relation, another constraint is imposed.

(21) Condition on Dependence

No node may depend on itself.

The point here is simply that if antecedence provides the reference for a term which cannot refer on its own, and if the antecedent is contained in a larger referential expression which depends on the original term whose interpretation one is trying to determine, then the interpretation cannot be determined. A violation of this condition is illustrated by the sentence

(22) The day her husband arrived is the day his wife left,
 assigned the following phrase marker at SS.

(23)

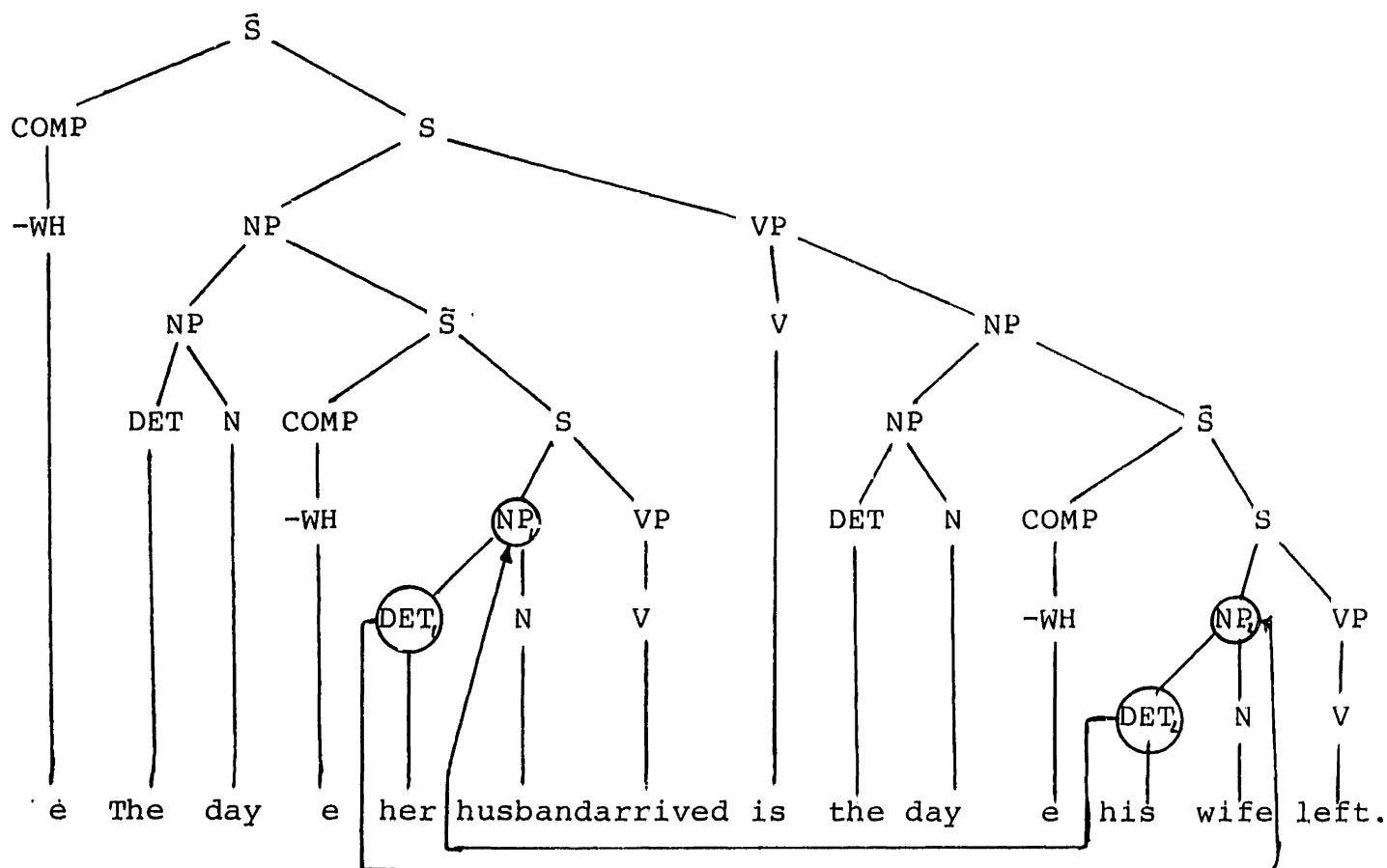

For DET_2 is linked to NP_1 and NP_1 contains DET_1 , so DET_1 depends on DET_2 . But DET_1 is linked to NP_2 and NP_2 contains DET_1 , so DET_1 depends on DET_1 . And since dependence is a transitive relation DET_1 depends on itself and DET_2 depends on itself.

1.2.3 LF and Conditions on LF

LF is, of course, the crucial component for the empirical issues pursued in this thesis. Elements of this component are obtained from elements of SS by a movement rule. The rule, move α , is instantiated for English with α taking the value of the first noun phrase node dominating Q which is not itself immediately dominated by another noun phrase node. Now Q is a kind of determiner. The exact set of Q will be discussed later. For the time being, I shall consider paradigmatic quantifiers of English to be "every", "some", "any", and "no".

The movement rule substitutes a phrase marker of the form (3) for a QNP in the phrase marker in question. This QNP is then adjoined to the S node of the phrase marker: that is, the QNP is appended to an S node which itself is written above the S node of the marker. An example will make this clear. In the following phrase marker of SS,

(24)

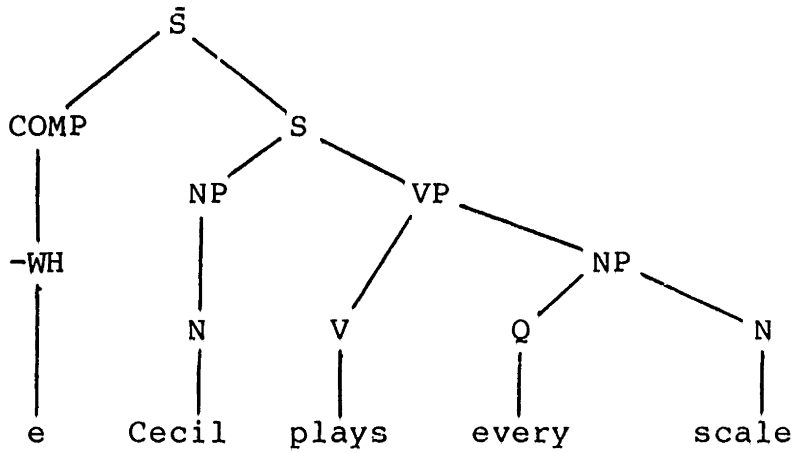

there is a Q, "every". QR applies to it, adjoining the QNP, "every scale" to the only node available for adjunction, to yield the following phrase marker at LF:

(25)

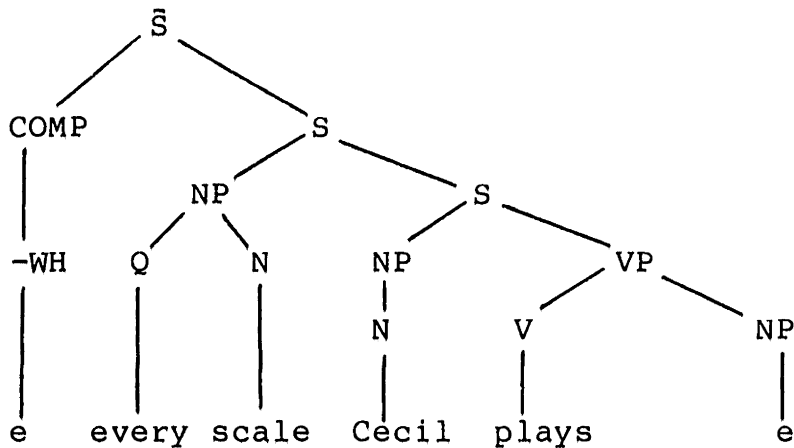

Recall from the discussion in the last section that each instance of movement creates an instance of linking. This applies at LF as well as at SS. Thus, the correct representation

at LF of (25) must be given as

(26)

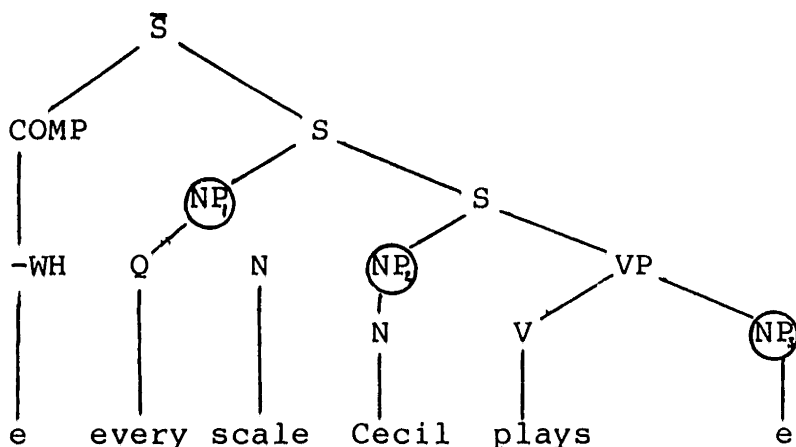

It is convenient to introduce two terms: "variable" and "bind". These terms, borrowed from logic on the basis of an evident analogy, are to be defined in a way which departs from their recent use by Chomsky.

(27) Definition of variable

y is a variable of x iff (1) x is a QNP,
 (2) x has been moved, and (3) y is linked to x .

(28) Definition of binding

x binds y iff (1) y is a variable of x and
 (2) x c-commands y .

In the example above, NP_3 is a variable, since it is a variable of the QNP, NP_1 . Furthermore, NP_1 binds NP_3 , since it c-commands NP_3 . Given these definitions, one may state, following

May (1977), the following conditions on LF phrase markers.

(29) Conditions on LF

1. Every QNP binds one variable.
2. Every variable is bound by one QNP.

Notice that if (29) is to be met, QR must apply at least once to each QNP in a phrase marker.

In the example considered above, (26), the relation of linking at SS is empty. Consider a case where it is not.

(30)

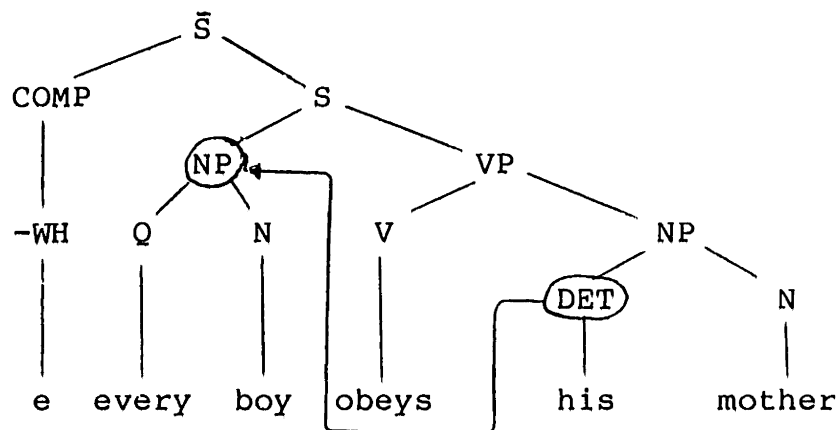

QR applies to yield:

(31)

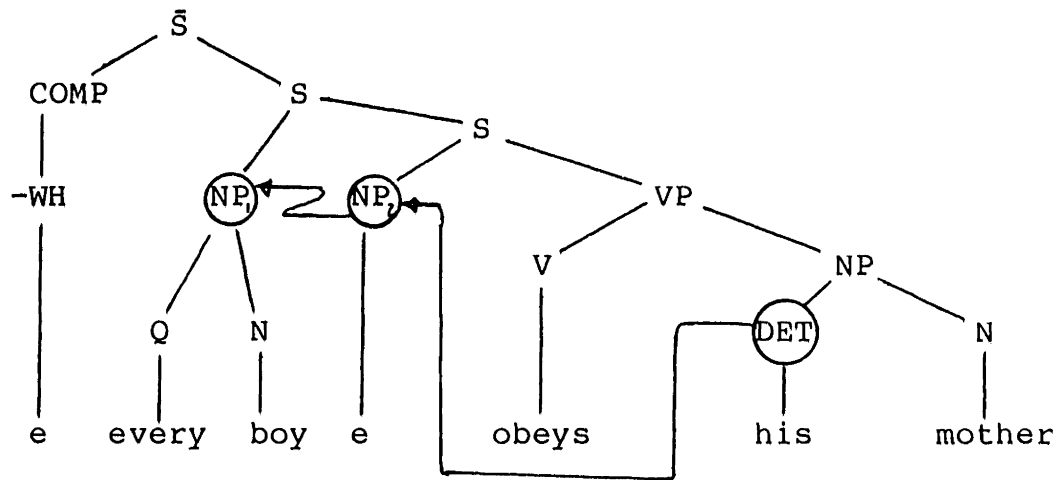

It should be obvious that linking at SS, which provides antecedents for arguments which do not determine their own referents, couples with linking at LF to furnish the reading for the sentence,

(32) Every boy obeys his mother,

for which the interpretation is that Billy obeys Billy's mother, Johnny obeys Johnny's mother... Of course, there is also the interpretation in which every boy obeys just one person's mother. But this is just the case where DET is not linked at SS to the QNP. At this point, it should be observed that this analysis presupposes another condition, not of LF but of semantic interpretation, namely,

(33) Condition on Reference

A referring expression gets its reference in one and only one way.

There is another kind of configuration at LF to be considered, since it is of singular pertinence to the issues examined in this thesis: the possible configurations available at LF for phrase markers at SS with more than one QNP. Here is an example:

(34)

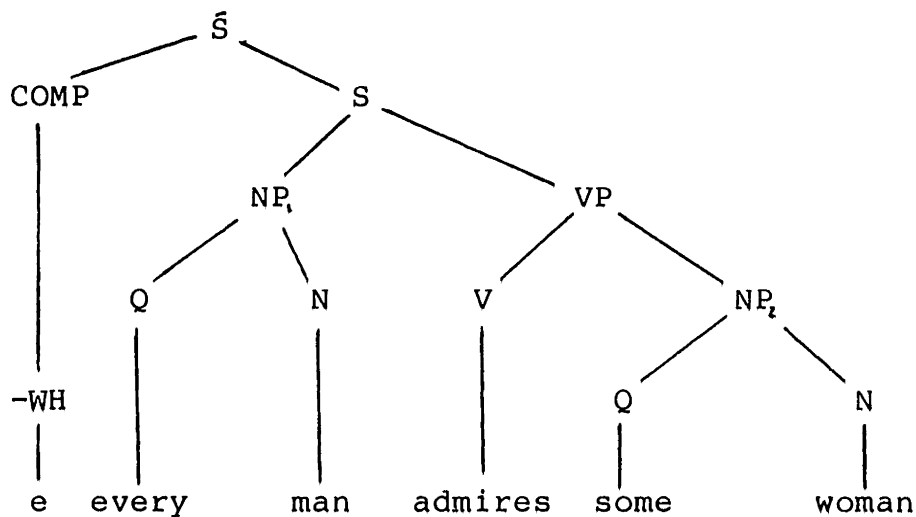

QR has two QNPs to which to apply. Now, whereas in earlier examples, the phrase marker provides only one site for the adjunction of the QNP, here, after QR has applied once, thereby yielding a phrase marker with two S nodes, QR has a choice of two sites for adjunction (either of the two S nodes) when applied to

the other QNP. Thus, in terms of (34), if QR applies just to NP_1 , then it creates an S node in adjoining to the S node in (34). When QR applies to NP_2 , it can adjoin NP_2 to one of two S nodes, in one case NP_1 c-commands NP_2 and in another case NP_2 c-commands NP_1 .

(35)

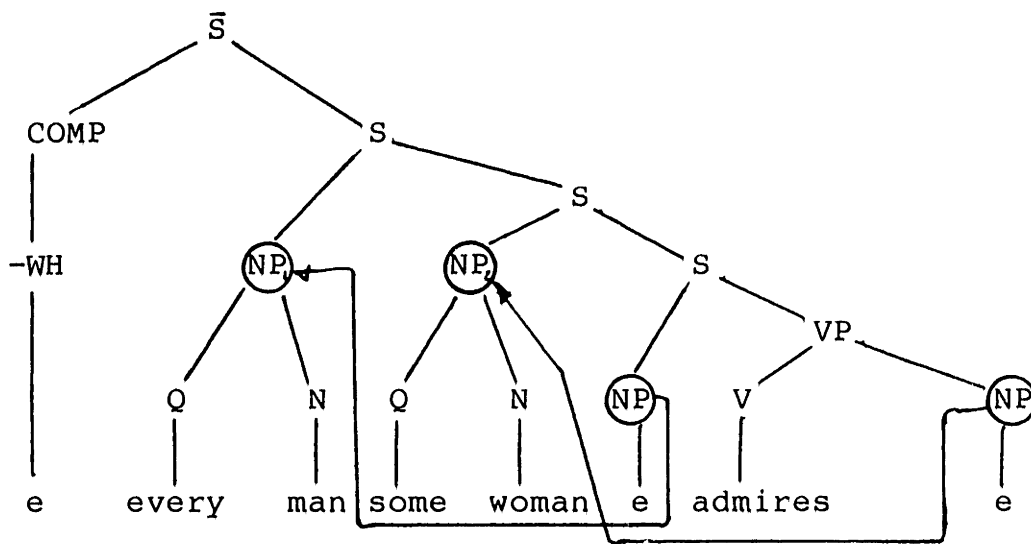

(36)

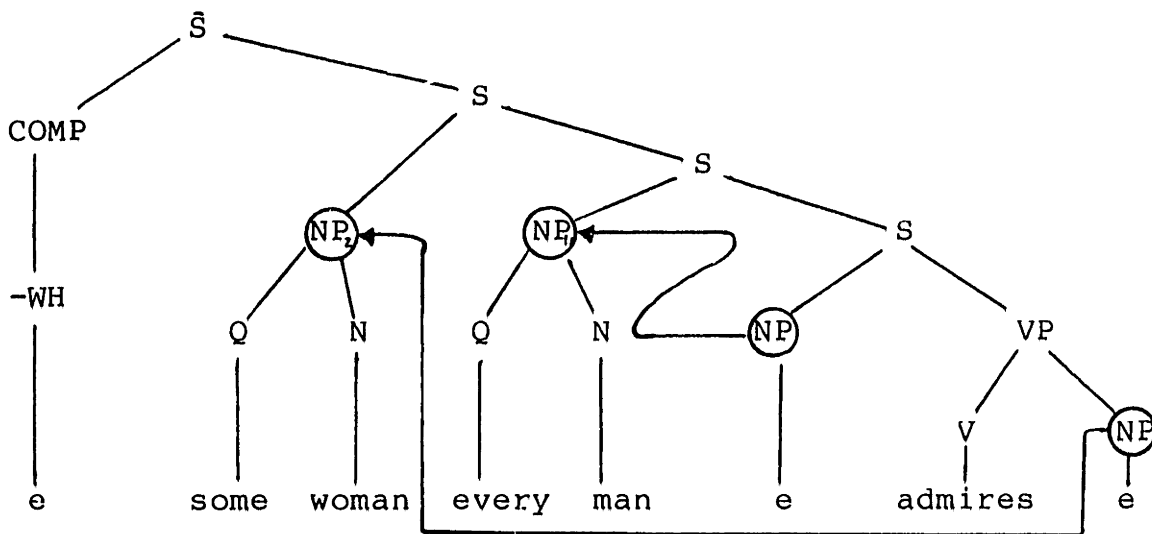

(Notice that the same pair of phrase markers are obtained even if QR applies to NP_2 first and NP_1 second.)

As one will have undoubtedly observed, the sentence
(37) Every man admires some woman

is ambiguous. On one reading, the sentence asserts that for each man there is a woman whom the man admires. On another reading, it asserts there is a woman whom every man admires. The difference in these two readings, as expressed in terms of logic, is that in the first reading the quantified noun phrase "some woman" is within the scope of the quantified noun phrase "every man" and in the second reading the quantified noun phrase "every man" is within the scope of the quantified noun phrase "some woman". This ambiguity is implicit in the fact that QR associates with the phrase marker at SS (34) the pair of phrase markers at LF, (35) and (36). It is made explicit through adopting the following hypothesis concerning scope.

(38) Hypothesis Concerning Scope

Let x and y be quantified noun phrases in a phrase marker at LF. x is in the scope of y if and only if y c-commands x .

Thus, in (36), where QNP_2 , "some woman", c-commands QNP_1 , "every man", "every man" is in the scope of "some woman"; but in (35),

where QNP₁, "every man", c-commands QNP₂, "some woman", "some woman" is in the scope of "every man". QR, then, can be understood as the rule that scope must be assigned to QNPs in sentences of natural language.

It is worthwhile, in concluding this discussion of QR and LF, to consider one more example, not only as it will illustrate further the concepts and principles introduced in this section of the chapter (1.2.3) but also as it will bear out an important point made in an earlier section (1.1), namely, that a different and richer explanatory framework is made available when the object of study in linguistics is shifted from acoustic disturbances which is language to the capacity to use language.

Before considering the next example notice that QR implies that any simple English sentence with two QNPs will have a pair of logically inequivalent interpretations when the pairs of quantifiers are not equivalent under commutation. QR, then, seems to have some obvious counterexamples. The following sentence has two quantifiers which do not commute preserving logical equivalence:

(39) Some oak grew from every acorn.

Its phrase marker at SS is

(40)

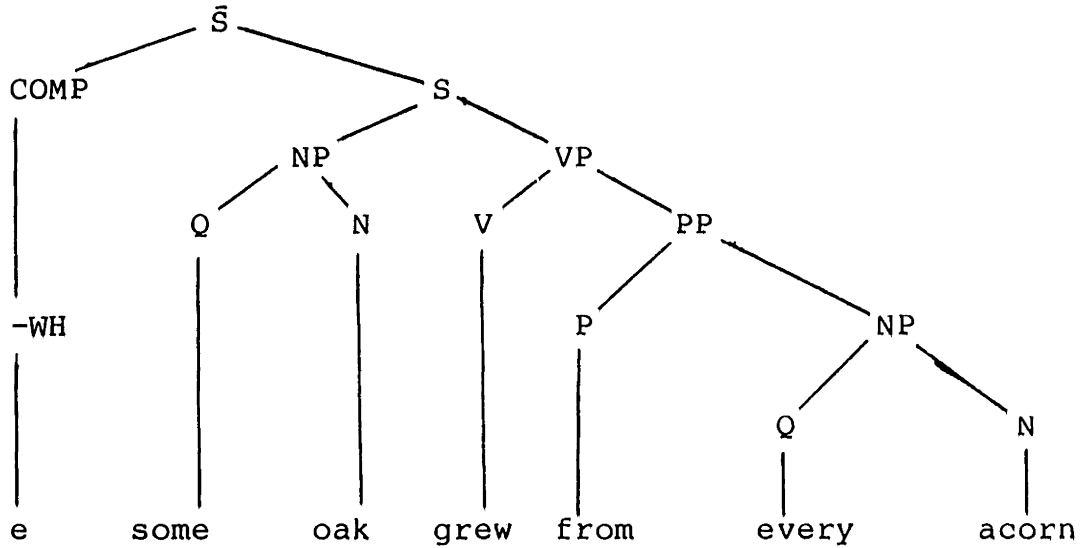

Yet it seems to have only one reading: For every acorn there is some oak which grew from it. Its phrase marker at LF is

(41)

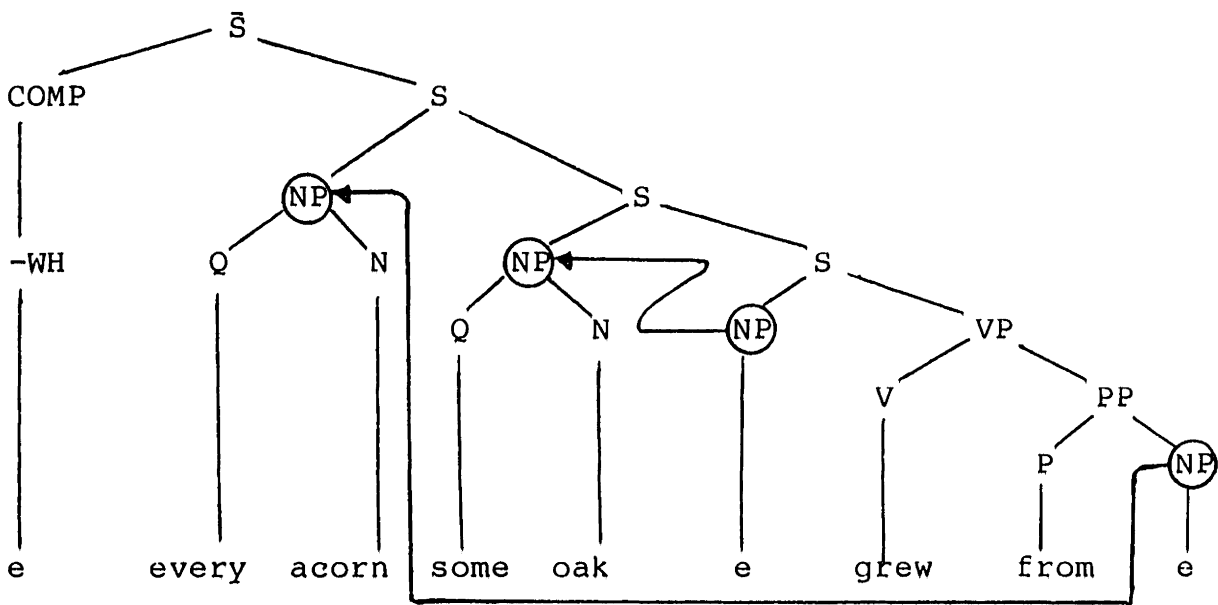

The other interpretation of (41) -- namely, there is an oak which grew from every acorn -- is not available. That is, the following example is not permitted:

(42)

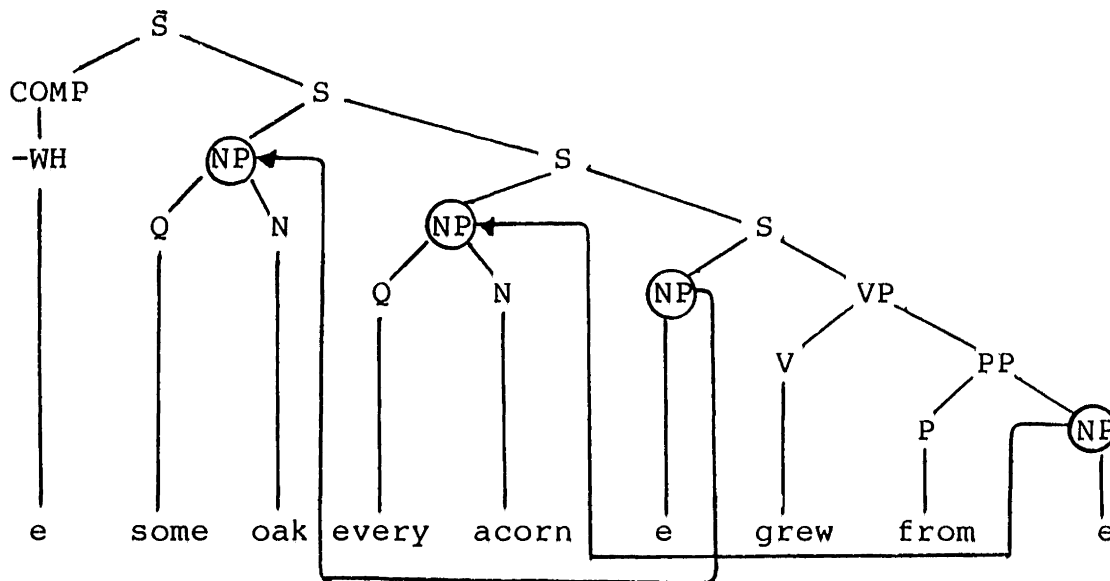

No doubt (39) is deviant. But is it grammatically deviant? QR implies that it is not. And unlike a linguistic framework which sets as the object of study mere utterances, the linguistic framework being worked in here, which takes as its object of study the human capacity to use and understand language, affords one an alternative to the human grammatical capacity (i.e., UG) as a source of the deviance of (39), namely, the conceptual and doxic capacities, among others, that is, one of the capacities which, together with UG, interact to provide each normal human being with a capacity to use and understand language. The

evidence that the deviance of (39) is doxic and not grammatical, is two-fold. First, sentences in every other way like (39) do have the two kinds of readings ascribed to (39) by (41) and (42). Consider this sentence:

(43) Some bird flew from every acorn.

It is suited to express the situation in which one bird flew away from acorn after acorn. And it is also suited to express the situation in which there are groups of birds around each acorn and from each acorn one of the birds grouped around it flew away. Second, the very idea of one oak growing from a collection of acorns -- as opposed to growing from one acorn in a collection -- is contrary to human beliefs of how oaks grow from acorns. The reading imparted to (39) by (42) is not grammatically unacceptable, but factually unacceptable.<8>

1.3 Conclusion

This completes the basic exposition of the theory of grammar underpinning this thesis. Included in this exposition has been not only a discussion of the broader framework of this theory (1.1) but also the details of the syntax insofar as they bear on the task ahead (1.2). In the next two chapters, I shall define, in terms of their syntax, a class of sentences, and then provide principles for their semantic interpretation.

FOOTNOTES·CHAPTER ONE

1. These points are familiar to readers from Chomsky (1965: Chapter 1), (1968: Chapter 5), (1976: Chapter 1), and (1980: Chapter 1).
2. Again, these points are familiar to readers from Chomsky (1968: Chapter 5), (1976: Chapter 2), (1980: Chapter 5), and especially (1977: Chapter 2).
3. Chomsky (1965: 57-58); and Chomsky (1976: 4-6).
4. For a clear, detailed and elementary presentation of the topic addressed here, the interested reader should consult Radford (1981).
5. This section is essentially a synopsis of points adopted from Higginbotham (1983).
6. By "asymmetric" I mean that if a pair of elements are related, the converse pair is not (i.e., if aRb then not bRa).
7. This definition of the relation of c-command is adopted from Reinhart (1976).
8. At the same time, many speakers prefer to assign wider scope to the quantified noun phrase in the subject position when both the subject and object contain quantified noun phrases. Indeed, languages like Mandarin Chinese observe this as a syntactic constraint (Huang 1982: 4.1.1.4 (59)).

CHAPTER TWO

THE SYNTAX OF SIMPLE SENTENCES

2.0 Introduction

I shall now undertake to provide an analysis of the semantics of what I take to be an interesting class of sentences. There are two important assumptions underlying it. The first is the usual assumption made in the treatment of the semantics of natural language, namely, that the analysis be provided in two stages: the semantic interpretation of a sentence as a function of its parts and the semantic interpretation of a sentence's most basic parts. The principles of semantic interpretation governing the former stage are the recursive semantic principles and the ones governing the latter stage are the basic semantic principles. The second assumption is essential to the methodology of the linguistic framework adopted here. It is the assumption that the syntactic and semantic principles of U.G., while autonomous with respect to one another, nonetheless interact systematically. (See 1.1 above.) These two assumptions combine to provide the basic hypothesis of the proposal to be developed now: namely, that the recursive

semantic principles apply to a phrase marker at LF and that the basic semantic principles apply to its lexical terminals. It is intended that the class of sentences examined below is fully semantically characterized by the recursive principles to be proposed. But it is not intended that each member of every lexical category which can appear in the class of sentences to be examined below is fully semantically characterized by the basic semantic principles. Omitted from the purview of the basic semantic principles are mass nouns. Though the omission of some lexical categories from treatment means a simplification of the task undertaken here, nonetheless it does not mean an abjuration of the implication that the proposal can be extended to subsume these categories.

I stated above that I shall provide the semantic analysis of so-called simple sentences. Given the assumption that the recursive semantic principles apply to the phrase markers of sentences, I need to define what I mean by "simple sentence". Roughly, a simple sentence consists either in a subject, which is a simple noun phrase, and a verb in the active voice, which is intransitive, or in a subject and object, both of which are simple noun phrases, and a transitive verb in the active voice. The following sentences are not simple.

(1)

1. The man who would be king is now president.
2. Gandhi did not believe that the English would leave India willingly.
3. The athlete ran quickly.
4. There's a Jackson in your house.

In more technical terms, a simple sentence is one whose phrase marker at DS contains at most a simple noun phrase and a verb phrase, and the verb phrase contains at most a verb and a simple noun phrase. (The term "simple noun phrase" will be defined below.) Such sentences are these:

(2)

1. Everyone likes Jesse.
2. The army retreated.
3. Jake contemplated the outcome.

The balance of this chapter is devoted to the problem of providing a syntactic characterization of a simple noun phrase.

2.1 The Simple Noun Phrase: Syntax

Obviously, for the notion of a simple sentence to be of any use, some definition of the term "simple noun phrase" has to be set out. The structure of the noun phrase has yet to receive its

definitive treatment, but there is enough expert agreement as to what any adequate analysis must include to permit me to define "simple noun phrase". Typically, the noun phrase is subject to the following phrasal rules:<1>

(3)

1. NP ----> NP \bar{S}
2. NP ----> ($\left\{ \begin{array}{l} \text{DET} \\ \text{NP's} \end{array} \right\}$) (AP) N
3. NP ----> NP CONJ NP
4. N ----> N (PP) ($\left\{ \begin{array}{l} \text{PP} \\ \bar{S} \end{array} \right\}$)

Some of these structures are exemplified below.

(4)

1. [_{NP} [_{NP} the man][_S who sat under the Bodhi tree]]
2. [_{NP} [_{DET} the][_{AP} tall][_N ships]]
3. [_{NP} [_{NP} the prisoner's][_N effects]]
4. [_{NP} [_{DET} every][_N [_N gallon][_{PP} of oil][_{PP} from Libya]]]
5. [_{NP} [_{NP} [_{DET} the][_N mayor]] [_{CONJ} and][_{NP} [_{NP} his] [_N wife]]]
6. [_{NP} [_{DET} the][_N [_N girl][_{PP} from Ipanema]]]

None of these phrases is a simple noun phrase, for a simple noun phrase is defined to be one which contains no other phrases.

More precisely,

(5) Definition of a Simple Noun Phrase

A noun phrase is simple if and only if the NP node dominates no other phrasal nodes or any S node.

(6)

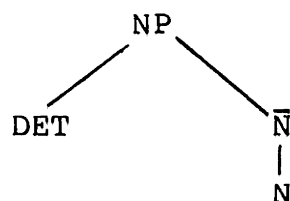

No more than this much phrasal structure is found in these examples.

(7)

1. [_{NP} John]
2. [_{NP} [_{DET} every][_{N̄} man]]

Now there is no mystery about (6), but there is some mystery about what exactly is encompassed within the lexical categories of determiner and noun. And it is to this mystery that I turn presently.

2.1.1 The Syntactic Taxonomy of Determiners

The paradigmatic instances of determiners have been the articles, definite and indefinite, to use traditional grammatical

terminology. More recently, determiners have come to include any word denoting quantity. In particular, determiners are taken to include not only words such as a, some, every, each, any, all, no, many, most, few, but also the cardinal numerals. Notice that this implies that the class of determiners is unbounded. In contrast, I submit that this class is bounded, containing perhaps not more than a dozen or so items. To see why I propose this, one needs to consider what kinds of lexical items can, and do, appear before the noun which is the head of a noun phrase.

According to the phrase structure rule presented above, the structure of the noun phrase insofar as the head and its preceding categories are concerned is defined by this rule:

(8)

$$NP \text{ ----} \rightarrow (\left\{ \begin{array}{l} NP's \\ DET \end{array} \right\}) \quad (AP) \quad \bar{N}$$

Now pre-head noun phrases are marked by an 's.<2> So, the problem of ascertaining the extension of the class of determiners is a matter of ascertaining what those elements are which are not adjectives yet occur before the noun in a noun phrase which contains no prenominal NP's. The crucial property is that determiners do not iterate. It turns out that this property, applied to phrase markers of the kind stipulated in (8), is sufficient to distinguish adjectives from determiners. This

implies that many lexical items, previously treated as "quantifiers", are adjectives. This implication may be considered suspect, if one does not bear in mind the syntactic and semantic heterogeneity of adjectives. To allay such a suspicion and to obviate objections to the view of determiners adopted here, I shall adduce some syntactic and semantic generalizations about adjectives.<3>

The naive view of adjectives is that they are all like such adjectives as tall, rich, erroneous, beautiful, etc. What these have in common is that each can be predicated of a noun in a simple copulative sentence:

(9)

1. John is tall.
2. The man is rich.
3. All beliefs are erroneous.
4. This is beautiful.

Such adjectives I shall call "predicative adjectives". Clearly they attribute qualities to things. But there are many adjectives which are not predicative, namely cardinal and thematic ones. Cardinal adjectives are adjectives which say something about the size of a set. Obviously they include the cardinal numerals, one, two, three, Thematic adjectives are

adjectives which say something about thematic (or case) relations borne by a thing picked out by the adjective to a thing picked out by the noun it modifies.<4> Examples are provided in a table below.

AGENT	a presidential lie	a lie by a president
PATIENT		
BENEFICIARY	an avian sanctuary	a sanctuary for birds
INSTRUMENT	a solar generator	a generator using the sun
LOCATION	marine life	life in the sea
MATERIAL	a molecular chain	a chain made out of molecules
POSSESSOR	a musical comedy	a comedy which has music
POSSESSEE	reptilian scales	scales had by a reptile
CAUSE	malarial mosquito	a mosquito which causes malaria
EFFECT	thermal stress	stress caused by heat.

Table 1

Notice also that the adjectival noun phrase and its paraphrase by a prepositional noun phrase observe similar selection

restrictions. Thus, a lie requires an animate agent, hence the oddity both of chemical lies and its paraphrase lies by chemicals.

But more important than these semantic properties characterizing each type of adjective are their syntactic properties. Consider this pair of frames:

(10)

1. DET A N
2. DET N { who } is A
 [which]

(10.1) and (10.2) provide equally acceptable expressions when A is replaced by a predicative adjective.

(11)

1. the tall man: the man who is tall
2. this rich lawyer: the lawyer who is rich
3. some erroneous belief: some belief which is erroneous

A disparity in the acceptability of expressions occurs when A is replaced by a thematic or cardinal adjective.

(12)

1. the five fish: ?the fish which are five
2. the solar generator: *the generator which is solar

3. a presidential lie: *a lie which is presidential

Second, cardinal and thematic adjectives do not take comparative and superlative lexical forms: *fiver, *sevenest, *malarialer, *marinest.<5> Incidentally, thematic and cardinal adjectives do not take adverbial modifiers of degree (e.g., very), whereas some predicative adjectives do. Third, no adjective of one class may co-ordinate by means of the conjunction and with an adjective of another.

(13)

1. *five and tall players
2. *handsome and two friends
3. *malarial and large mosquitoes
4. *rich and criminal lawyers
5. *eight and logical fallacies
6. *musical and three comedies

(14)

1. *five and six politicians
2. *tall and handsome incubus
3. *solar and lunar generator

Fourthly, predicative adjectives iterate with themselves, but cardinal and thematic adjectives do not.

(15)

1. a tall pregnant woman
2. *the lunar solar module<6>
3. *these five six attendants

Moreover, when these adjectives iterate with one another, they observe a definite order: namely, cardinal adjectives precede predicative adjectives and predicative adjectives precede thematic ones.

(16)

1. five tall players
2. *handsome two friends
3. large malarial mosquito
4. *malarial large mosquito
5. rich criminal lawyer
6. *criminal rich lawyer
7. eight logical fallacies
8. *logical eight fallacies
9. three, large, ugly, reptilian scales
10. *large, ugly, reptilian, three scales
11. *reptilian, three, large, ugly scales
12. *three, reptilian, large, ugly scales

	Cardinal	Predicative	Thematic
admits paraphrase by a relative clause whose verb is <u>to be</u>	?	yes	no
takes comparative or superlative forms	no	some	no
takes adverbial modifiers of degree	no	some	no
iterate with themselves	no	yes	no
co-ordinate with an adjective from another class	no	no	no
linear order	1st	2nd	3rd

Table 2

While the generalizations encapsulated in the table above hold by and large, there are some noteworthy anomalies. Consider the four adjectives many, much, few, and little. They have comparative and superlative forms.

(17)

1. many, more, most
2. much, more, most
3. few, fewer, fewest
4. little, less, least

Yet they do not admit acceptable pairs of expressions in which

they are substituted for A in (10.1) and (10.2).

(18)

1. many Americans: *Americans who are many
2. much gold: *gold which is much
3. few students: *students who are few
4. little food: *food which is little.

Moreover, they do not co-ordinate with other predicative adjectives, or freely iterate with them.

(19)

1. *many and rich bankers
2. *rich and many bankers
3. many rich bankers
4. *rich many bankers

Now it might be thought that many and few are cardinal adjectives, for, like the cardinal numerals, they indicate the size of the set denoted by the noun they modify. But unlike the other cardinal numbers, these do not co-ordinate with them or with each other.

(20)

1. *many and few diplomats
2. *two and many capsules
3. *few and three tablets

4. *four and five policemen

Another candidate for the class of cardinal adjectives is several. But it too fails to co-ordinate with other cardinals, or even those which were just discussed.

(21)

1. *several and three enzymes
2. *two and several soldiers
3. *many and several professors
4. *several and few lakes

Yet several precedes both predicative and thematic adjectives.

(22)

1. several friendly customers
2. *friendly several customers
3. several national banks
4. *national several banks

These anomalous adjectives, I shall call "quasi-cardinals".

Having completed this sketch of some of the syntactic and semantic properties of adjectives, I return now to the problem of delineating the class of determiners. Like any ill-understood category, the determiner has served as a repository for words which seem to be entangled in a web of idiosyncratic properties.

The paradigmatic cases of determiners have been the articles, definite and indefinite -- to use terms from traditional grammar. As I said before, determiners have come to include any word denoting quantity, and in particular, to include the cardinal numerals.<7> This implies the class of quantifiers, and hence the class of determiners is infinite. In contrast, I hold the class of determiners to be made up of three lexical categories: demonstratives (DEM), which include what have traditionally been called "demonstrative adjectives"; interrogatives (INT), which includes the interrogative adjectives of traditional grammar; and quantifiers (Q). The lexical items in each category are listed in the following table.<8>

DEM	singular	a	the	this	that	
	plural		the	these	those	
INT	singular	which		what		
	plural	which		what		
Q	singular	a, some		each, any, every		no
	plural	some		all		no

Table 3

Excluded from this table are the cardinal numbers and the quasi-cardinals many, few, most and several.

What justifies their exclusion from the class of

determiners? Determiners cannot be iterated with one another.

This is borne out by the facts set out below.<9>

DEM DEM:	*that a car	DEM DEM:	*a that car
DEM INT:	*this which tie	INT DEM:	*which this tie
DEM Q :	*the each election	Q DEM:	*each the election
INT DEM:	*What the friends	DEM INT:	*the what friends
INT INT:	*which what lawyer	INT INT:	*what which lawyer
INT Q :	*what some guard	Q INT:	*some what guard
Q DEM:	*some these cars	DEM Q :	*these some cars
Q INT:	*no which contrivance	INT Q :	*which no contrivance
Q Q :	*any no essay	Q Q :	*no any essay

Table 4

In contrast, almost any determiner may precede a cardinal or quasi-cardinal adjective.

DEM CARD:	$\left\{ \begin{array}{l} \text{the} \\ \text{this} \\ \text{that} \end{array} \right\}$	one	book
	$\left\{ \begin{array}{l} \text{the} \\ \text{these} \\ \text{those} \end{array} \right\}$	$\left\{ \begin{array}{l} \text{two} \\ \text{three} \\ \text{four} \end{array} \right\}$	books
	$\left\{ \begin{array}{l} \text{the} \\ \text{these} \\ \text{those} \end{array} \right\}$	$\left\{ \begin{array}{l} \text{many} \\ \text{few} \\ \text{several} \end{array} \right\}$	books

INT CARD: {which } one book
 {what }

 {which } {two } visitors
 {what } {three }

 {which } {many }
 {what } {few } supplies
 {several }

Q CARD: { *a }
 { some }
 { *each } one lamp
 { *every }
 { any }
 { no }

 { some } { five }
 { all } { six } proposals
 { no } { seven }

 { some } { many }
 { *all } { few } errors
 { no } { several }

Table 5

Moreover, no cardinal or quasi-cardinal may precede any determiners.

CARD DEM: *one {the } book
 {this }
 {that }

 { *two } {the } friends
 { *three } {these }
 { *four } {those }

$\left. \begin{array}{l} *many \\ *few \\ *several \end{array} \right\}$	the	lots
	these	
	those	

CARD INT:	*one	$\left. \begin{array}{l} \text{which} \\ \text{what} \end{array} \right\}$	writer
-----------	------	--	--------

	$\left. \begin{array}{l} *two \\ *nine \end{array} \right $	$\left. \begin{array}{l} \text{which} \\ \text{what} \end{array} \right\}$	docks
--	---	--	-------

	$\left. \begin{array}{l} *many \\ *few \\ *several \end{array} \right\}$	$\left. \begin{array}{l} \text{which} \\ \text{what} \end{array} \right\}$	bombings
--	--	--	----------

CARD Q:	*one	$\left. \begin{array}{l} a \\ \text{some} \\ \text{each} \\ \text{every} \\ \text{any} \\ \text{no} \end{array} \right\}$	container
---------	------	---	-----------

	$\left. \begin{array}{l} *five \\ *six \\ *seven \end{array} \right\}$	$\left. \begin{array}{l} \text{some} \\ \text{no} \\ \text{all} \end{array} \right\}$	reflections
--	--	---	-------------

	$\left. \begin{array}{l} *many \\ *few \\ *several \end{array} \right\}$	$\left. \begin{array}{l} \text{some} \\ \text{no} \\ \text{all} \end{array} \right\}$	stamps
--	--	---	--------

Table 6

Now a view which maintains that cardinals and quasi-cardinals are quantifiers, and hence determiners, is

committed to a rather strange anomaly: these would-be quantifiers are the only ones which may iterate with the other quantifiers and determiners, but they may iterate only once and may never precede the other quantifiers and determiners. On the view here, there is no anomaly: the facts of ordering result from the syntax of the noun phrase and the traditional lexical categories, both facts being independently grounded.<10> There is another fact which militates in favor of this view: it is precisely the cardinals and quasi-cardinals which, if treated as quantifiers, fail to exhibit the scopal relations demanded by QR.

2.1.2 The Syntactic Taxonomy of Nouns

There are three disjoint categories of nouns: proper names, pronouns, and common nouns. Common nouns themselves fall into two disjoint categories, count nouns and mass nouns. Examples are these:

Proper Names:	Harry, Poona, the Ghats, the Hague, ...
Pronouns :	this, whom, what, I, himself, each other, ...
Common Nouns:	
Count Nouns :	bottle, friend, proposal, thinker, ...
Mass Nouns :	gold, bread, experience, oats, news, ...

Table 7

Proper names and pronouns do not occur with determiners, but

common nouns may. Proper names and mass nouns do not admit the contrast between singular and plural. This classification is represented in the following matrix.

	occurs with a determiner	admits the contrast of singular and plural
Proper Name	-	-
Pronoun	-	+
Mass Noun	+	-
Count Noun	+	+

Table 8

To sustain the plausibility of this classification, one must bear in mind two facts. First, lexical rules, which map lexical entries into lexical entries, need not alter every co-ordinate of an entry which is the pre-image of an application of a rule. In particular, a lexical rule need not alter the phonological co-ordinate of an entry. Second, the morphology of a lexical item in a surface sentence is not a simple projection of the item's associated syntactic features.

I shall elaborate on this latter fact before I undertake to show how these facts bear on the problem of the syntactic

taxonomy of nouns. To say that the morphology of lexical items in a surface sentence is not a simple projection of the items' associated syntactic features is to say that it is not the case that for each syntactic feature there is a unique morphological realization and that each morphological realization of a syntactic feature is a unique realization. That is to say, the denial is the denial of any bijection between the set of syntactic features and some subset of the morphological realizations of these features. However, to assert this denial is not to assert that there is no systematic interaction. Indeed, there is. It is a fact about the syntactic component of grammar that different lexical items admit of different syntactic features. In the situation at hand, it is a fact of the syntactic component that pronouns and count nouns admit the syntactic features of plurality and singularity (i.e., +PL and -PL), but that proper names and mass nouns do not. At the same time, it is a fact of the morphological component of grammar that each word must be inflected. Now, English inflectional morphology is impoverished: except for pronouns, English nouns are inflected only with (morphological) number: the inflection for morphological singular is phonetically null and the inflection for morphological plural is phonetically realized as s or as ablaut, idiosyncratic cases aside (e.g., medium, media).

The result of these facts is that those nouns which admit the contrast in syntactic features -PL or +PL have those features realized in terms of the phonetically appropriate morphological singular and plural, but also nouns which do not admit the contrast in these syntactic features must acquire either singular or plural morphology. It is this requirement of the morphology which accounts for the facts that some proper names may be morphologically singular (e.g., Harry, The Hague) but other morphologically plural (e.g., The Andes); and that some mass nouns may be morphologically singular (e.g., gold, experience) and others may be morphologically plural (e.g., oats, news). At the same time, lexical rules map proper names and mass nouns into count nouns often with a concomitant shift in meaning. As a result, one encounters such expressions as the Jake, this he, bread, Parises, etc. This is evidenced by these sentences.

(23)

1. The Jake I know is not the Jake you know.
2. This he refers to someone other than whom that he refers to.
3. How many breads does this bakery carry?
4. Are there any Parises in New York State?

Note that if a mass noun is assigned singular morphology, its correspondent, if any, among the count nouns acquires the

appropriate morphological singular or plural, depending on the lexical item's syntactic feature of +PL or -PL. But, if the mass noun is assigned plural morphology, its correspondent, if any, among the count nouns will not be able to assimilate a further morphological contrast (e.g., oats).

Having established the basic syntactic lexical categories pertaining to nouns, one might observe the following about the size of the categories: while there is no bound, or at least no clear bound, on the size of the categories of proper name and common noun, there is a clear bound on the category of pronoun. Indeed, one can easily list them, as is done here.

ENGLISH PRONOUNS<11>

Demonstrative Pronouns		-PL	something, someone		this	that
		+PL	some		these	those
Personal Pronouns	1st	-PL	I	me	my	mine
		+PL	we	us	our	ours
	2nd	-PL	you	you	your	yours
		+PL	you	you	your	yours
	3rd	-PL	he	him	his	his
			she	her	her	hers
			it	it	its	---
		+PL	they	them	their	theirs

Interrogative	-PL	who,whom	which	what	
	+PL	who,whom	which	what	
Quantifying Pronouns	-PL	someone something	each everyone everything	anyone anything	none nothing
	+PL	some		all	none
Pronominals	-PL	he she it	him her it	his her its	his hers ---
	+PL	they	them	their	their
Trace		t			
Relative Pronouns	-PL	who,whom,whose	which	what	
	+PL	who,whom,whose	which	what	
Reflexive Pronouns	-PL	myself	yourself	himself,herself, itself	
	+PL	ourselves	y'ourselves	themselves	
Reciprocal Pronouns		each other, one another			

Table 9

2.1.3 Syntactic Features and the Noun Phrase

Above, when the notion of syntactic feature was first broached, it was raised in connection with nouns and their syntactic singularity and plurality. In languages where there is agreement between the head of a noun phrase and its specifiers, the question arises as to how the agreement is to be achieved. I suggest these assumptions.

(24)

1. Every lexical item acquires a maximally consistent set of syntactic features chosen from among the ones it admits.

This is vacuously borne out in the case of lexical items which admit of no syntactic features. Where lexical items do get syntactic features, (24.1) guarantees that there is no failure to assign a syntactic feature in some category. Thus, for example, if English adjectives were inflected for gender, (24.1) would insure that exactly one syntactic feature of gender be assigned. Some English noun admit of the syntactic features of number (+PL), so (24.1) insures that exactly one of the two features be assigned.

Moreover, I suggest these:

(24)

2. If X is the head of a phrase XP, then the set of syntactic features assigned to X are assigned to XP.
3. If Y is a determiner in a phrase XP, then the syntactic features of Y are consistent with the syntactic features of XP.

They combine to account for the following distribution of acceptability of noun phrases.

this table
*these table

*this tables
these tables

that dart
*those dart

*that darts
those darts

$\left\{ \begin{array}{l} \text{each} \\ \text{every} \\ \text{any} \\ *all \end{array} \right\}$ friend

$\left\{ \begin{array}{l} *each \\ *every \\ *any \\ all \end{array} \right\}$ friends

Table 10

FOOTNOTES - CHAPTER TWO

1. These rules were suggested by Jim McCloskey in lectures given in his classes at MIT in the fall of 1983.
2. The view I adopt here is that personal pronouns undergo a systematic phonetic shift (to possessive personal pronouns) in the environment ___'s. (See the third column under the entry for personal pronouns in Table 9 in 2.1.2 below.) For the sake of expository ease, I treated possessive personal pronouns as determiners in the first chapter.
3. The account here is based on the work of Levi (1978). Levi (1978) studies the systematic contrast between thematic and predicative adjectives, called by her "non-predicating" and "predicating" respectively.
4. Sensitivity to this distinction can be found in Aristotle's Categories (Chapters 1 and 8: 1a12ff and 10a27ff).
5. This is not to say that there cannot be homophones of these adjectives which do, or could, permit these forms; but such an adjective is derived from its homophone by a lexical rule. This is borne out by the fact that a shift in meaning. Thus, for example, some predicative adjectives do not admit comparative and superlative forms: *squarer, *squarest. When such forms do occur, there is a shift in meaning; in particular, the quality denoted becomes one which admits of intensification. For example, squarer means something like more closely resembling an ideal square.
6. Both Sylvain Bromberger and Noam Chomsky have brought to my attention such acceptable combinations as: royal marine biologist, musical lunar module.
7. See: Jackendoff (1977: Chapter 5), May (1977), and others.
8. The reason for the double occurrence of a will be brought out in 3.1.1 below.
9. There is only one apparent exception: all the men, all those men, all these men. But, as I shall show, all permits the elision of of in partitive constructions. (See 5.1 below.) There is also, of course, the idiom every

which way. It was brought to my attention by Sylvain Bromberger and Jeff Pelletier.

10. Of course, there is the option of treating cardinal numerals and quasi-cardinal numerals as being both adjectives and determiners.
11. This table is not complete. It is here for the reader's convenience and to convey the idea of just how many items are encompassed in this category.

CHAPTER THREE

THE SEMANTICS OF LEXICAL ITEMS

3.0 Introduction

I stated at the outset of the last chapter that two crucial assumptions are at work here. First, I assumed that the principles of syntax and those of semantics are to be stated in independent terms, though these principles interact in systematic ways. Second, I assumed that the principles of semantic interpretation apply in a recursive fashion to categories and structures provided by the syntactic principles. As I indicated before, the phrase markers at LF provide the structure to which the recursive semantic principles apply and the lexical items, which are the terminals of these phrase markers, provide the elements to which the basic semantic principles apply. In the next chapter, I shall state and illustrate the recursive semantic principles; in this chapter, I shall state only the basic semantic principles. Since the task is to state the principles of interpretation for simple sentences, in stating the principles interpreting lexical items I shall confine my attention to the (syntactic) lexical categories which enter into simple sentences: the determiner, the noun, and the verb. The

interpretation of some of the lexical items within each of these categories will be explored below.

3.1 Determiners Interpreted

Although the determiner is not a unified semantic category, each of its three subcategories -- the demonstrative, the interrogative, and the quantifier -- is. I shall leave it for another occasion to treat the semantics of interrogatives, instead I shall concentrate my attention on the semantics of demonstratives and quantifiers, in that order. The problem of stating their semantics is complex; to simplify, I shall give only a preliminary account here, leaving some questions open, pending further developments in the rest of this chapter.

3.1.1 Demonstratives Interpreted

As is well-known, demonstratives depend on the situation of their utterance for their complete interpretation. That is to say, the same demonstrative uttered in the same sentence, but in different circumstances, can have a different reference. The question naturally arises: what part of the interpretation of a demonstrative results from its lexical meaning and what part from the circumstances of its utterance? This question must be addressed, if a satisfactory characterization of the lexical

semantics of demonstratives is to be provided. And to answer this question, one must furnish an analysis, at least in broad outline, of the pragmatic and semantic facts, insofar as they impinge on the interpretation of demonstratives. So although the problem here is that of the semantic interpretation of demonstratives, nonetheless I must provide an analysis of those aspects of pragmatics which bear on the interpretation of demonstratives.

Essentially, a demonstrative, when used felicitously, supplies the addressee of the utterance in which it occurs with enough information so that the addressee, through that information and through his knowledge of the context, can settle on the denotation of the noun phrase, which is among the denotation of the head noun. The information provided through the utterance of the demonstrative can be modulated by paralinguistic means, for example, by pointing or nodding. This modulation, in effect, reduces the size of the context of utterance. In fact, just what has been said so far describes the deictic use of the definite article. The demonstrative adjectives this and that differ from the definite article insofar as the information provided by one is that the denotation of the noun phrase is near whereas that provided by the other is that the denotation is not near.

The foregoing needs to be made more precise. To that end, let me introduce the notion of a canonical situation of utterance (Lyons 1977: 637ff.). It is the situation taken to be embodied in typical occasions of utterance. There are one or more participants, one of whom is the utterer, the remainder of whom are addressees. The participants share a perceptible environment which includes a phonic medium for the vocal-auditory channel of the utterer. The utterer himself, at the moment of utterance, is at the origin of a spatiotemporal co-ordinate grid from which distance is measured. Although the canonical situation of utterance must involve much more than this, the description just given is sufficient to provide the definition of certain features, namely, the features +DEICTIC and the features +PROXIMATE. To be deictic is to be locatable in the situation of utterance by any of the participants in it. To be proximate is to be near the origin of the situation of utterance. These two properties, defined in terms of the canonical situation of utterance, are defined for any given situation of utterance insofar as the canonical situation is realized. Demonstratives have some of these features as part of their lexical meaning; but how these properties or relations, which interpret lexical features, fare on any given occasion of utterance, depends on how the canonical situation of utterance is instantiated.

How, then, are demonstratives to be interpreted? As a first step in the answer to this question, it is convenient to decompose the lexical entry of a demonstrative into semantic features. The definite article, the, has only one feature: +DEICTIC. The demonstrative adjective, this, has two: +DEICTIC, +PROXIMATE; and the demonstrative adjective, that, also has two: +DEICTIC, -PROXIMATE. The semantic interpretation of demonstratives is a Boolean function of the functions assigned to each feature. The functions assigned to the features have subsets of the domain of interpretation as their domains and subsets of objects in the situation of utterance as their ranges. As it will turn out, the interpretation of a demonstrative is essentially that of an adjective, except the range of the function assigned to a demonstrative is subsets of the objects in the situation of utterance, whereas the range of the function assigned to an adjective is subsets of the domain of interpretation. I shall defer further specification of the nature of such functions until a later chapter where I discuss the interpretation of adjectives (See 5.2.1 below).

I should point out that the things which can be deictic or proximate need not be restricted to physical things in the situation of utterance. The on-going utterance itself can be deictic and, as the utterance stretches over time, parts of it

can be more or less proximate to the origin of the situation of utterance. To see this, consider someone going through a proof by reductio ad absurdum. Arriving at the next to the last step, he says, referring to the previous thing expressed: but this claim is false. Moreover, objects and events can be considered deictic and proximate (or not) insofar as the utterance which expresses them are deictic and proximate (or not). For example, having just expressed some fact, one can refer to it by saying "this fact is of fundamental significance."

The decomposition of the demonstratives into features suggests the question: is there a demonstrative which has the feature -DEICTIC? I believe there is; it is the indefinite article a, which has no phonetically realized plural form. And, I believe, it is this indefinite article and its phonetically null plural form which account for so-called specific readings of the indefinite article and many cases of so-called bare plurals. The plausibility of the former view is suggested by the fact that the specific interpretation of a has resisted successful treatment as a quantifier (Ioup 1977). And indeed, this view has confirmation in recent research.<1> Assuming, then, that it is correct, the question of a phonetically null plural form of the indefinite article is re-opened. Greg Carlson (1977) has argued for the view that there is no such plural counterpart, but his

argument was based on the assumption that the indefinite article is a quantifier in all its occurrences.

3.1.2 Quantifiers Interpreted

Let me turn from the interpretation of demonstratives to that of quantifiers. It is generally agreed that the quantifiers of natural language are properly represented by restricted quantifiers. Restricted quantifiers, first introduced by Rosser (1953), and developed by Hailperin (1957), are a departure from the syntax of first order predicate logic. It was thought that their use would permit a closer correspondence between the parlance of mathematics and the formulae of logic. Thus, sentences like the ones in (1) were not thought to be properly paralleled by the formulae in (2):

(1)

1. Some prime number is even
2. Every prime number greater than two is odd
3. No prime number greater than two is even

(2)

1. $\exists x (Px \wedge Ex)$
2. $\forall x (Px \wedge x > 2 \rightarrow Ox)$

$$3. \quad \forall x (Px \wedge x > 2) \rightarrow \neg Ex$$

(where "E" means "even", "O" means "odd", and "P" means "prime number"). It was thought that just as the quantifiers in (1) are restricted to the domain circumscribed by the nouns in the subject, so the quantifier in the formula should be restricted to the domain circumscribed by logical predicates. To this end, the syntax of first order predicate logic was modified so as to permit open sentences in the quantifiers, and these open sentences restricted the domain of quantification of the quantifier to that part of the domain of interpretation satisfying the open sentence. The sentences of (1), then, are formulated in the syntax of restricted quantification as follows<2>:

(3)

1. $(\exists x: Px) Ex$
2. $(\forall x: Px \wedge x > 2) Ox$
3. $(\forall x: Px \wedge x > 2) \neg Ex.$

To see how this alteration in the syntax of first order predicate logic is handled by the semantics, recall that quantifiers in first order logic can be interpreted as two-place functions. The first place of the function takes its values in the domain of interpretation and the second place takes its values in the set of n-place propositional functions (i.e., the

n-place functions which are assigned to n-place predicates, taking n-tuples of individuals in the domain of interpretation and yielding one of the Boolean values $\{0,1\}$). And the range of the function assigned to the quantifier is the set of (n-1)-place propositional functions. Now when restricted quantifiers are permitted by the syntax, the values which the first place of the quantificational function takes are in a subset of the domain, namely, the one whose members satisfy the predicate in the restricted quantifier.

It was first suggested by Staal (1960), I believe, that the logical form of quantified noun phrases is that of a restricted quantifier. This has now become the general view. Typically, the function interpreting a quantifier in natural language takes values in a subset of the domain. This subset is furnished by the denotation of the balance of the noun phrase in which the quantifier occurs. It takes as its other value the propositional function which interprets the verb to which the quantified noun phrase is an argument. But this account fails to provide for the fact that quantifiers admit the syntactic feature +PL. With this shortcoming in mind, I suggest the following modification of the interpretation of quantifiers.

(4) Principle of Interpretation of Quantifiers

Let D be a domain of individuals. The power set of D

is the domain of interpretation. Let Q be a quantifier. Q^D is a two-place function. Its first place takes values in a subset of the domain of interpretation; its second place takes values in the set of n -place generalized propositional functions (i.e., n -place functions which take as values n -tuples of subsets of the domain and which yield as values one of the Boolean values $\{0,1\}$). Q^D yields values in the set of $(n-1)$ -place generalized propositional function.

The grounds for this approach to quantification in natural language will become clear when the interpretation of simple sentences themselves is addressed in the next chapter. (See 4.3 below.)

3.2 Nouns Interpreted

As was pointed out previously, nouns are of four kinds: proper names, pronouns, and common nouns which are either mass or count. I shall not treat here the principles of semantic interpretation pertaining to mass nouns.<3> Instead, I shall attend solely to those pertaining to proper names, pronouns, and count nouns.

3.2.1 Count Nouns and Proper Names Interpreted

The basic principle is this:

(5) Principle of Interpretation of (non-mass) Nouns

Let D be the domain of individuals. The power set of D is the domain of interpretation

1. If N is a proper name, then its interpretation in

D is a member of D (i.e., $N^D \in D$);

2. If N is a pronoun or count noun, then its interpretation in D is a subset of D (i.e., $N^D \subseteq D$), namely, its extension in D.

3.2.2 Pronouns Interpreted<4>

The foregoing encapsulates all that is germane to the semantic interpretation of proper names and count nouns. This is because all the information required for interpretation is encoded into their lexical entries. However, more needs to be said about pronouns: in addition to what is specified in their lexical entries, some of them require syntactic relations to other items in the same sentence to finally be interpreted, and others of them require conditions definable in terms of the situation of utterance to be met to finally be interpreted. Pronominals, trace, reflexive, reciprocal, and relative pronouns depend on their syntactic relations for interpretation; demonstrative and personal pronouns depend on the situation of utterance for interpretation; and quantifying and interrogative pronouns are fully interpretable through their lexical entries.

Let me begin my discussion of the principles governing the semantic interpretation of pronouns by setting forth those pertaining to anaphoric pronouns. By "anaphoric pronouns", I mean pronominals, trace, reflexive, reciprocal, and relative

pronouns. In referring to these as anaphoric pronouns, I depart somewhat from current usage and hark back to traditional usage. This term is used here to characterize semantically a subset of a syntactic class; that is, this term is used to refer to that subset of pronouns (a syntactic category) whose semantic interpretation depends on links they have with other elements in the sentences in which they occur.

The interpretation of anaphoric pronouns depends on the relation of antecedence, which is defined over phrase markers at SS and is modulated by certain general conditions. (See 1.2.2 above.) There, unlike here, no distinction is made between third person personal pronouns and pronominals. Under the syntactic taxonomy implicit there, it is necessary to stipulate that on any given use of the third person personal pronoun, only one of the principles of semantic interpretation applies. (See (33) of 1.2.3 above.) That is, one needs to pre-empt a personal pronoun from being given an interpretation through deixis and through its antecedent. However, under the syntactic taxonomy adopted now, no such stipulation is necessary since there is only one principle to apply to any given lexical item. In light of this reclassification, it will prove useful to restate the syntactic conditions on the relation of antecedence.

Recall that the relation of antecedence is the transitive closure of the relation of linking. (See (16) of 1.1.2 above.) Linking, one will remember, is a binary relation, which is asymmetric, and hence, also irreflexive. Nodes on a phrase marker are linked in accordance with the following.

(6) Rule of Linking

Every instance of movement assigns a link from the node from which there is movement to the node to which there is movement.

Thus the set of links on a phrase marker is augmented with each instance of movement. But anaphoric elements must be provided with an antecedent; and linking is the available device whereby one is provided. So, in addition, phrase markers at SS must meet the following condition:

(7)

Every anaphoric element whose immediately dominating noun phrase node is unlinked is to be linked to another noun phrase node.

This linking at SS is subject to three more conditions.

(8)

1. No anaphor c-commands its antecedent.
2. The syntactic features of an anaphor and its antecedent agree.<5>
3. No anaphor depends on itself.

Cases of sentences violating these conditions are provided

below:

(9)

1. * [_{NP} He] thinks [_{NP} Oscar] is terrific.
2. * [_{NP} Herself] likes [_{NP} Mary].
3. * [_{NP} Each other] want [_{NP} the friends] to succeed.
4. * [_{NP} He] thinks [_{NP} she] is terrific.
5. * [_{NP} Mary] likes [_{NP} himself].
6. * [_{NP} He] [_{NP} which] is without funds should come forward.
7. * The day [_{NP} [_{NP} her] husband] arrives is the day [_{NP} [_{NP} his] wife] leaves.

Finally, note that sentences like (9.1) to (9.3) can never be grammatical, for in each case there is no noun phrase node to which the noun phrase node of the anaphor can be properly linked. (9.1) has a counterpart which is grammatical: it is the sentence just like (9.1) except that it has a third person personal pronoun instead of a pronominal; in that event the third person personal pronoun is interpreted through deixis.

The anaphors of trace, relative pronouns, reflexive pronouns, and reciprocal pronouns are subject to a strengthened version of (8.1), namely,

- (10) The antecedent of a trace, relative, reflexive, or reciprocal pronoun c-commands it.

This condition is known to hold for trace: a phrase never moves to a position which does not c-command its trace. It is also clear that it holds for relative pronouns from the very structure of relative clauses. This is illustrated below:

(11)

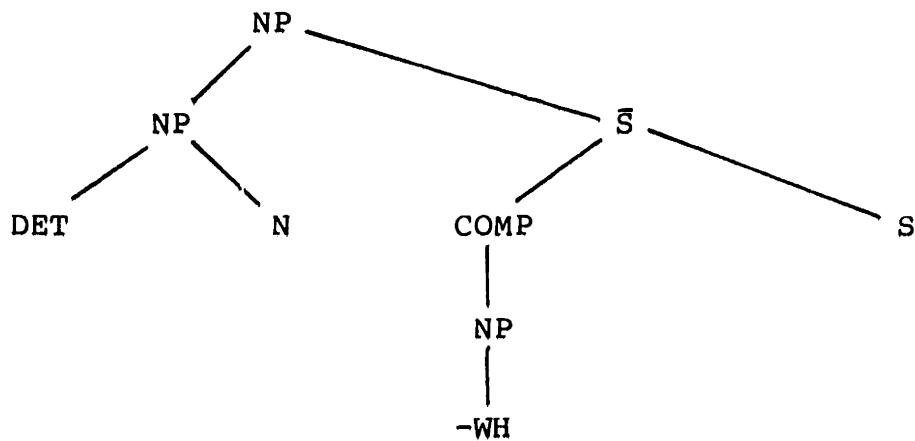

Moreover, under all current analyses of the extraposition of relative clauses, the antecedent still c-commands the WH phrase (Chomsky 1981: 56, n. 39).

In connection with this discussion of conditions on anaphors, it is appropriate to mention a lexical idiosyncrasy of reciprocal pronouns: they always have the syntactic feature of +PL. This lexical fact of reciprocal pronouns combines with (8.2) above to yield an account of the following distribution of

grammatical and ungrammatical sentences.

(12)

1. *Eliza saw each other.
2. The women saw each other.

Nor should this distribution be viewed as a matter of common sense, (that is, a non-grammatical matter) for collective nouns, nouns which denote collections of objects, are never antecedents of reciprocal pronouns, unless they bear the syntactic feature +PL.

(13)

1. *The army shot at each other.
2. *The swarm flew after one another.

And this understanding is further favored by the fact that even those count nouns whose morphology precludes the morphological realization of the contrast between the syntactic features of +PL or -PL are clearly interpreted as referring to a set whose cardinality is greater than one, when the noun phrases containing them are the antecedent of a reciprocal pronoun (Fiengo and Lasnik 1973: 452).<6>

(14) The binoculars are focussed differently from each other.

Having set forth the syntactic conditions on the basis of which anaphoric elements come to acquire their denotation, one

can now state the very simple principle governing their semantic interpretation: An anaphor is assigned the same denotation as its antecedent. More formally,

(15) The Principle of Interpretation for Anaphors:

Let D be a domain of individuals. Let the power set of D be the domain of interpretation. Let A be an anaphor and NP be its antecedent. Then $A^D = NP^D$.

The reader should bear in mind that the reciprocal pronoun has a still further condition imposed through its lexical entries. This will be explored in detail later. (See 4.3.2 below.)

Having completed this presentation of lexical interpretation of anaphors, I now turn to that of demonstrative and personal pronouns. It is generally held that the interpretation of demonstrative and personal pronouns depend, not wholly, but nonetheless to a great extent, on the situation of their utterance. And indeed, reverting to the notion of the canonical situation of utterance and using the device of features assigned to a lexical entry, one can provide an analysis of the lexical interpretation of these pronouns. The following table of correspondences between demonstrative pronouns and simple noun phrases which contain demonstratives as determiners provides the clues as to how the analysis should go in the case of demonstrative pronouns.

Simple Noun Phrases whose DET's are DEM's	Demonstrative Pronouns
this one these ones	this these
that one those ones	that those
the one the ones	*** ***
some one (thing); a one some ones (things)	someone (thing) some

Table 10

It seems, then, that demonstrative pronouns have, in their lexical entries, the (semantic) features which their corresponding demonstratives have, thereby determining properties defined within the situation of utterance, and that they are assigned sets, in accordance with the fact that they are nouns, whose extension is that of their lexically assigned semantic features insofar as these features are realized in the situation of their utterance. Hence, this (these) is assigned the set of objects in the situation of utterance which are locatable within the situation of utterance (i.e., deictic) and are near (i.e., proximate). That (those) is assigned the objects in the situation of utterance whose objects are locatable within the

situation of utterance (i.e., deictic) and need not be near (i.e., not proximate). Finally, some (some) is assigned a set of objects which may not be locatable within the situation of utterance (i.e., not deictic).<7>

The personal pronouns too can be analyzed in terms of semantic features defined over the canonical situation of utterance and whose extension is determined on any given occasion of utterance as a result of the realization of the canonical situation. The first person personal pronoun is assigned the singleton which contains the utterer<8> and the second personal pronoun is assigned the set which contains the addressees. The third person personal pronouns have different features, namely, GENDER and DEIXIS. In a sense, these pronouns fill the gap in the paradigm of the demonstrative pronouns where there is no demonstrative pronoun corresponding to the simple noun phrase whose determiner is the definite article. (See Table 10 in 2.1.2 above.) That the third person personal pronoun may be deictic is clear. It is easy to see that the situation of utterance determines the reference of the pronouns as used below.

(16)

1. I wonder where he is off to?
2. I am glad he's gone.

One can see that by suitably changing the situation of their utterance, the third person personal pronoun will find a denotation or will not; and if it does find a denotation, it can vary from situation of utterance to situation of utterance. It is also clear that the fact that these pronouns are marked for gender provides further information for the determination of denotation. Finally, it is obvious that through suitable paralinguistic modulation of their utterance (i.e., through nodding or pointing) their denotation may be isolated in a situation of utterance in which the pronoun would otherwise fail to have its lexically specified features satisfied.

I pointed out, in connection with my treatment of demonstratives, that the utterance itself forms part of the situation of utterance and objects or events can come to be deictic in virtue of the utterance which denotes them. It is this phenomenon which accounts for cases of so-called discourse anaphora. And it is the fact that both preceding utterances as well as preceding parts of an utterance are part of the situation of utterance which permits so-called discourse anaphora to obtrude into sentences. And this fact furnishes the basis for an important observation due to Evans (1980).

He points out that sentences like the following permit the

free interchange of the quantifiers some and no.

(17)

1. Some congressman admires only the people he knows.
2. No congressman admires only the people he knows.

But, he notes (1980: 340), other sentences do not.

(18)

1. Some congressman admires Kennedy and he is very junior.
2. *No congressman admires Kennedy and he is very junior.

As it turns out, the sentential structure embodied in the first pair permits a referential dependence by the (anaphoric) pronoun on the noun phrase which is the subject of the sentence; and the sentential structure embodied in the second pair does not permit such referential dependence. The fact that the third person personal pronoun in (18.1) may indeed denote what is posited by the subject of the first part of the sentence, accrues, not from any referential dependence, but from deixis: the first part of the utterance, which forms part of the situation of utterance, posits (through the assertion of a complete sentence) the existence of some congressman, and it is in virtue of the utterance of the phrase, which, in the first independent clause uttered, posits some congressman, that the deixis of the third person personal pronoun succeeds. In contrast, the utterance of

(18.2) does not lead to the positing of any such individual which can be singled out by the subsequent use of the deixis of the third person personal pronoun. To be sure, this is not an idiosyncrasy of the quantifier no; it is a fact about what is asserted. Thus, consider this sentence.

(19) Some congressman does not admire Kennedy,
and he is very junior.

The deixis of the pronoun succeeds only when the quantifier has wider scope than the adverb not. To verify this, compare (19) to a gloss where the negative adverb is given wide scope with respect to the first independent clause.

(20) It is not the case that some congressman admires Kennedy,
and he is very junior.

Once again, the utterance of the first independent clause posits no entity for deixis by the personal pronoun.

From personal pronouns, I turn to quantifying and interrogative pronouns. As I said earlier, the semantics of interrogative pronouns will not be treated in this thesis, so I need only concentrate here on the lexical interpretation of quantifying pronouns. As with demonstrative pronouns, so with quantifying pronouns, their counterparts among the determiners provide clues as to their lexical interpretation.

Simple Noun Phrases whose DET's are Q's	Quantifying Pronouns
some one (thing) some ones (things)	someone (thing) some
any one (thing) every one (thing) each one (thing) all things	any; anyone (thing) everyone (thing) each all
no one (thing) no ones (things)	none (nothing) none

Table 11

Quantifying pronouns are construed as quantifying functions, just like quantifiers, except that the value assigned to the first value of the function associated with the quantifier is lexically determined. In the unmarked case, its values are in a set of subsets of the objects in the domain of discourse; and in the marked cases, its values are in a set of subsets of objects in the domain of discourse which are regarded as animate, indeed human (someone, anyone, everyone) or its value is the set of objects which are regarded as non-human (something, anything, everything).

3.3 Verbs Interpreted

In turning to the interpretation of verbs, I must address an issue which I have so far managed to avoid: do lexical items have an argument-structure? If so, which lexical items? And if a lexical item has an argument-structure, how is it to be represented in its lexical entry? And what is the relation between argument-structure and positions in a phrase marker? Any general treatment of the sentences of natural language must come to grips with all these questions. Some of these questions will be addressed in a more general fashion in a later chapter, (see 5.2.2 below) at least to the extent that the generalization of results in this chapter require it. In this chapter, I shall confine myself to treating the issue only to the extent as is required by the results aimed at in it.

Now, within the linguistic framework of this thesis, it is generally thought that verbs have argument-structure. This is taken to mean that the lexical entry of a verb has an n-tuple, each co-ordinate of which corresponds to an argument-place of the verb. In addition, I shall assume that each verb must have exactly one distinguished argument-place; the remaining argument-places are undistinguished.<9> Intransitive verbs have one argument-place; transitive verbs have two. By way of illustration, one could think of a lexical entry's specification of argument to appear as follows:

(21)

row (1*)
hit (1*,2)

Since a verb is to be assessed with respect to the noun phrases which are its subject and object, one must ask how the argument-places in the argument-structure of the verb are to be mapped into a phrase marker. To this end, I propose to define two relations over phrase markers.

(22) Definition of an External Argument Position<l0>

Let X and Y be nodes in a phrase marker, and in particular, let Y be a lexical category (Y°). X is an external argument position of Y if and only if (i) Y has a maximal projection $M(Y^\circ)$, (ii) $M(Y^\circ)$ and X c-command each other, and (iii) no other node dominating X c-commands $M(Y^\circ)$.

Definition of an Internal Argument Position<l0>

Let X and Y be nodes in a phrase marker, and in particular, let Y be a lexical category (Y°). X is an internal argument position of Y iff (i) X is a maximal projection and (ii) X and Y c-command each other.

On the basis of these definitions, a function which maps argument-places onto argument-positions can be defined.

(23) The Assignment of Argument-Places to Argument-Positions.

Suppose A is a lexical item with n argument-places and a_i ($1 \leq i \leq n$) are its associated argument-places. If a_i is undistinguished, then it is assigned to the internal argument-position with respect to the node which immediately dominates A; if a_i is a distinguished argument-place, then it is assigned to the external argument-position with respect to the node which immediately dominates A.

To see how these definitions work, let me set out a simple example.<11>

(24)

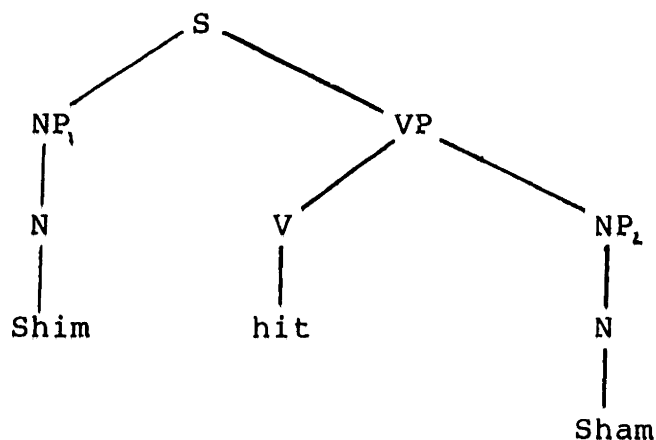

The external argument-position of the node V is the node NP_1 , since the maximal projection of the node V, namely the node VP, c-commands, and is c-commanded by NP_1 , and no other node dominating NP_1 c-commands VP. The internal argument-position of the node V is the node NP_2 , since NP_2 is a maximal projection,

and the nodes V and NP_2 c-command each other. If, then, hit is assigned to the node dominated by V , its distinguished argument is assigned to NP_1 and its undistinguished to NP_2 .

Given the syntax of the argument-structure of verbs and given how the argument-places in the structure is assigned to argument-positions in a phrase marker, one can formulate a semantic principle of lexical interpretation for a verb. A verb is to be interpreted as a "generalized propositional function". A generalized propositional function is simply a generalization of a propositional function familiar from first order predicate logic. To see what is meant by generalized propositional function, recall that n -place predicates of first order logic are interpreted as n -place (propositional) functions from n -tuples of individuals in the domain of interpretation into the Boolean values $\{0,1\}$. A generalized propositional function is an n -place function from n -tuples of sets of individuals in the domain of interpretation into the Boolean values $\{0,1\}$.<12>

(25) Principle of Interpretation for Verbs

Let D be a domain of individuals. Let the power set of D be the domain of interpretation. Let V be a verb with n argument-places. Then V^D is an n -place generalized propositional function into the Boolean values $\{0,1\}$ (1) which is defined over n -tuples of subsets of D , and

(2) whose i th place corresponds to the i th argument-place of V .

Thus, row is assigned a one-place function from subsets of the domain of interpretation into Boolean values $\{0,1\}$ and the argument-place of row corresponds with the argument-place of its function. Hit is assigned a two-place function from pairs of subsets of the domain of interpretation into Boolean values, the first argument-place of the verb corresponds to the first argument-place of the function, and the second argument-place of the verb corresponds to the second argument-place of the function.

3.4 Conclusion

The task which I undertook in the second chapter and I shall bring to a close in the next is the statement of the semantic principles of interpretation for simple sentences. The second chapter gave the syntactic analysis of simple sentences and this chapter gives the semantic principles of interpretation which apply to some of the lexical items in the lexical categories of determiner (namely, quantifiers and demonstratives), noun (namely, count nouns and proper names), and verb.

FOOTNOTES - CHAPTER THREE

1. Subsequent to the initial draft of this chapter, Peter Ludlow brought to my attention the article by Fodor and Sag (1982), which shows exactly this point: the indefinite article has both a quantificational interpretation, to be represented by a quantifier, and a referential interpretation, to be represented as a demonstrative.
2. It is well-known that for the quantifiers discussed here, the formulae in (3) can be defined in terms of those in (1).
3. For an overview of the problem, see: Pelletier and Schubert (1984).
4. There are a number of approaches to the syntax and semantics of these items within the linguistic framework adopted in this thesis. For discussion of this point, see Bouchard (1982). I have selected an approach conducive to my expository ends.
5. As Noam Chomsky pointed out to me, this condition must be refined to handle anaphors with split antecedents. (For example, in the sentence "Michael told Martha that they should get married", "Michael" and "Martha" are both antecedents of "they".)
6. Among such nouns are those which Jespersen (1909: Part II, Sect. 7) calls "composite objects". Typically, these nouns denote objects made up of two similar parts. Examples include: trousers, pants, glasses, and binoculars.
7. Though I shall not do so here, it is easy to provide the interpretation of demonstrative pronouns on the basis of the interpretation of their corresponding demonstrative adjective and the lexical rule connecting demonstrative adjectives with pronouns.
8. Notice that the first person personal pronoun, when plural, is assigned the appropriate non-singleton which includes the speaker.
9. The view here is a modification of that of Williams (1981). For a detailed exposition of this modification see Gillon (work in progress).

10. The maximal projection of a verb node is the first phrase node dominating it; and the maximal projection of a noun node is the first noun phrase node dominating it. $M(V) = VP$ and $M(N) = NP$.
11. The \bar{S} node has been omitted here and in subsequent phrase markers as its inclusion is a needless complication.
12. The reason for the use of generalized propositional functions in the interpretation of verbs will be made clear in the next chapter.

CHAPTER FOUR

THE SEMANTICS OF SIMPLE SENTENCES

4.0 Introduction

The task broached in the second chapter, namely, the interpretation of simple sentences, can be brought to a close. The principles introduced in the preceding two chapters and principles to be introduced below converge. As it happens, the point of convergence is the interaction of the interpretation of verbal structures (verbs or verb phrases) with the interpretation of nominal ones (noun phrases). To stave off unnecessary complication, I shall first address the recursive principles of interpretation which can be stated in relative isolation: the principle of interpretation for semantically vacuous branches of a phrase marker (at LF) and the principle of interpretation for simple noun phrases. Next I shall turn to the fact that plural noun phrases are liable to so-called "collective" and "distributive" readings. In particular, I shall address the question of the division of labor between the semantic component of the grammatical capacity and the conceptual and doxic capacities insofar as such readings are concerned. As it turns out, a proper division of labor, together with the principles of

interpretation urged here, provides a straightforward and natural account of these readings. This is shown in the discussion which brings this chapter to culmination: namely, the discussion of the treatment of the interpretation of simple sentences, in which is incorporated the treatment of the interpretation of the verb phrase as well. Finally, I turn to a bonus of the semantic principles argued for in these chapters: a simple treatment of the interpretation of simple reciprocal sentences (i.e., simple sentences with reciprocal pronouns), a treatment which seemed out of reach in light of the facts adduced by Langendoen (1978).

4.1.1 Miscellaneous Points at Interpretation

A number of preliminary points should be attended to. The most general is the point pertaining to semantically vacuous nodes. Such a configuration is where one node immediately dominates another but does not immediately dominate any other. This is illustrated below:

(1)



What one wants to say in such cases is that the interpretation assigned to the dominating node (X) is the same as the one assigned to the dominated node (Y).

(2) Principle of Interpretation for Vacuous Nodes

Let D be the domain of interpretation. Let X be a node which dominates exactly one other node Y . Then $X^D = Y^D$.

Another point concerns the semantic treatment of the syntactic features +PL and -PL assigned to the NP node. The next principle is addressed to that end.

(3) Principle of Interpretation of Syntactic Features

Let D be a domain of individuals whose power set is the domain of interpretation. Let NP be a noun phrase node.

1. If NP is assigned the syntactic feature -PL, then $|NP^D| = 1$;
2. If NP is assigned the syntactic feature +PL, then $|NP^D| > 1$.<1>

This principle needs supplementation by a convention which relates a member of the domain of interpretation with a subset of the domain containing just that member. To state it, though, I need a few terms. Let me distinguish non-empty sets into two sorts: singletons, which have exactly one member, and non-singletons, which have more than one member. On the basis of this distinction, one can discern three disjoint classes of sets: the empty set, singleton, and non-singletons. Following Higginbotham (1981), I adopt the convention that singletons are to be identified with their members.<2>

(4) Convention for the Interpretation of Noun Phrases

In a semantic interpretation, a singleton and its member (e.g., {x} and x) are equivalent.

4.1.2 Simple Noun Phrases Interpreted

Obviously, every simple noun phrase must have a noun. But simple noun phrases need not have determiners. Where the noun is a pronoun or a proper name, it cannot have a determiner. Where the noun is a common noun, it need not have a determiner, or so it appears in at least some cases. I said earlier that I shall not be addressing the semantics of mass nouns; and I warn here that I shall not be pursuing the semantics of so-called bare plurals. The cases of simple noun phrases to be considered, then, are either structures with just a proper name or a pronoun, or structures with a determiner and a count noun. The latter structures are of three kinds: demonstrative with a count noun, quantifier with a count noun, and interrogative with a count noun.

I shall begin my discussion of the interpretation of simple noun phrases by considering those which contain either a mere pronoun or a mere proper name. Every such case has the following structure (where L is a proper name or a pronoun)

(5)

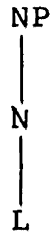

Now the principle in (4) (in 3.2.1 above) provides the interpretation of L. And principle (2) above provides the interpretation of N, namely that $N^0 = L^0$, and in turn of NP, namely that $NP^0 = N^0$. In short, (4) (of 3.2.1 above) and (2) combine to yield the result that $NP^0 = L^0$.

I now turn to the cases involving count nouns and determiners. Since interrogatives are not to be dealt with here, there remains only the cases of quantifiers and demonstratives with count nouns. Some of the analysis required must await further development of the ideas pertaining to the predicate-argument structure of lexical items. What remains to be said at this point follows from earlier remarks on the semantic principles governing quantifiers and demonstratives and the syntactic principles pertaining to syntactic features. I shall assume that syntactic features are assigned freely to all lexical items which admit them. In the case of the simple noun phrase, this means that syntactical features, in particular, those of singularity and plurality (i.e., +PL and -PL), are freely assigned to count nouns, demonstratives, and quantifiers.

Furthermore, the syntactic features of the noun are assigned to the noun phrase node itself. (See (24.1) of 2.1.3 above.) The specifiers, in this case, demonstratives and quantifiers, which in fact do admit features, must match those of the projection of the head to which they are specifiers. (See (24.3) of 2.1.3 above.) In this case, the assumption means that the features (syntactic) of demonstratives and quantifiers must match those of the noun phrase node, which receives its features from its head.

At this point, it is useful to return to some points made earlier (in 4.1.1 above) about syntactic features. To begin with, though, recall that proper names do not occur in simple noun phrases with determiners. (See Table 8 in 2.1.2 above.) So, in a simple noun phrase the noun phrase node does not branch and does not dominate any other node which branches. Hence, by the principle in (2) above, the interpretation of the noun phrase node dominating a proper name is the same as the interpretation of a proper name, namely, an individual. But remember that from the point of view of semantic interpretation, an individual and the singleton set containing it are equivalent. Therefore, the cardinality of the noun phrase node dominating the proper name is one. (See (4) in 4.1.1 above.)

Another important point to underscore is that simple noun

phrases containing singular count nouns must have a denotation whose cardinality is one. This requirement, stated in (1.1) above, applies even if the count noun in question is, conceptually speaking, plural. Such a class of nouns are the collective nouns (Jespersen 1909: Part II, Sect. 4.8). It includes such words as: forest, army, swarm, library, train. Forest picks out a collection of trees, army a collection of soldiers, swarm a collection of insects (of one kind), library a collection of books (as opposed to a building housing them), and train a collection of cars. Each of them admits the contrast of singular and plural (i.e., -PL and +PL).

4.2. Collective and Distributive Readings

This last issue is absolutely central to the semantics of even simple sentences. I shall consider it here only insofar as it pertains to the semantics of simple sentences. Here, the issue surfaces as the problem of how collective and distributive readings of sentences are to be treated. What is the difference between collective and distributive readings? Let me begin with an example of a sentence clearly susceptible to each of these readings.

(6) The men rowed.

It is read distributively, if the action of rowing is taken to

hold of each man denoted by "the men"; it is read collectively, if the action holds of the men taken as a collection. To see this more clearly, imagine that "the men" denotes Rick and Randy. Suppose that Rick was in one boat and rowed, while Randy was in another and rowed. Surely (6) can be used to express this fact. In such a case, row holds of Rick and Randy distributively. In contrast, suppose that Rick and Randy were in one boat, each pulling on one of two oars. This situation too is expressed by (6). But this time row holds of Rick and Randy collectively. It does not take much imagination to see that collective and distributive readings can get pretty complicated fast. As the next sentence can be true, even if no one servant is involved in carrying any one box all the way home.<3>

(7) The servants carried the boxes home.

Confronted with such data, one seems to have two options. One can decide that the data does not bear on the grammatical capacity at all. The semantic principles make available one interpretation, and further construal results from other considerations, including conceptual and doxic ones. Or, one can decide that the grammar provides each and every reading. The correct analysis is, I believe, to be had from both. The semantics provides all the collective and distributive readings; the conceptual system provides objects of interpretation and the

doxic system provides what sort of properties or relations hold of what sort of objects. The interaction of these systems account, at least in part, for judgments of acceptability of sentences liable to collective and distributive readings. (See 1.1 above.) Evidence for this comes from several sources. Let me discuss them each in turn.

First, it is evident that it is the human conceptual and doxic capacities, and not the human grammatical capacity, which are responsible for regarding certain sentences as odd. That is, one might be tempted to regard the oddity of the following sentence as a grammatical fact. (See Kroch 1974: Ch.5, Sect. 5.0.)

(8) The soldier surrounded the town.

Regarding it as ungrammatical, one might naturally suggest that surround subcategorizes for a plural feature on the subject noun phrase. This conjecture receives some support from sentences like the following:

(9) The soldiers surrounded the town.

But such a conjecture is belied by the fact that the verb in question goes well with singular noun phrases for subjects where the noun phrase contains a collective noun.

(10)

1. The army surrounded the town.
2. The swarm of bees surrounded the town.

One might think, in response to these examples, that the restriction on the subject noun phrase is not syntactic but semantic, requiring a selection restriction instead, perhaps that the subject noun phrase denote a collective object. But this revision too runs afoul of the facts.<4>

(11)

1. The river surrounded the town.
2. The amoeba surrounded the paramecium.

Indeed, is (8) truly odd, let alone ungrammatical? What if there were a man whose height exceeded the circumference of a town? What about an adult of normal height and a town which is a miniature model? Consider (8) in light of the following scenario. A soldier is home on leave. He has given his child a toy, a miniature town. He is playing with his child and in doing so has managed to encircle the miniature town with his body (perhaps hiding it from the child). Would not (8) express this situation? The oddity of (8), when felt, accrues not from a violation of the rules of the grammatical capacity, but from a failure of the conceptual system to dream up, without some prompting, suitable objects. Compare

(12) The hand surrounded the coin.

Second, it is evident that the human conceptual capacity is responsible for finding suitable objects for the semantic interpretation. This is already implied by the discussion in the previous paragraph. But it is also implied by the semantic principles adopted in the earlier part of this chapter. Recall the principle that noun phrases which have the syntactic features of +PL or -PL are interpreted as singletons, if they have the feature -PL, and as non-singletons, if they have the feature +PL. Collective nouns, it was observed, admit these features, hence singular collective phrases are to be interpreted as singletons. The semantics is thereby committed to collective objects. Given that this step has been taken, one has no reason to balk at bringing collective readings of plural noun phrases under the same rubric.

The strength of the foregoing consideration is only as strong as the plausibility of the view that collective objects are the product of the conceptual capacity, and not the grammatical capacity. The evidence is that, in general, it is hard to see how one can deny that the task of determining an object is a conceptual one. The negative evidence is that the determination of a collective object depends crucially on all

kinds of extra-grammatical factors, such as knowledge of the world and its customs. Consider an army. It is a large organized body of men armed and trained for war and destined chiefly for land service. Do these same men constitute an army once the organization has broken down? Probably not. But is ascertaining such a fact part of the grammatical capacity's task? I don't see how. Note that these kinds of problems about collective objects have their analogue with non-collective ones. Consider a car. It is certainly an individual (as opposed to a collective) object. Now, imagine that it has been disassembled completely and its parts are arranged in order of size on the floor of a garage. Does the individual object, a car, still exist? Maybe it does and maybe it does not; but surely the grammatical capacity does not decide that!

Let me draw out further the connection between denotation of singular collective nouns and the denotation of plural nouns read collectively.<5> Reflect upon this sentence.

(13) The soldiers saw the Indians.

Let "the soldiers" denote the soldiers of F troop and let "the Indians" denote a band of renegade Indians. Now, consider this sentence in light of two scenarios. In the first, the soldiers of F troop are out tracking the band which is fleeing to Mexico.

The soldiers are properly deployed and the soldier riding point spots the Indian riding rear guard, none of the other soldiers being able to see any of the Indians and the soldier riding point not being able to see any of the other Indians. So here, one soldier sees one Indian, yet it seems fair to say the soldiers saw the Indians. In the second scenario, the soldiers of F troop are all on furlough and each has gone his separate way. The Indians of the band are each roaming the plains separately. Now the same soldier as before just happens to catch a glimpse of the same Indian as before. Surely in such a case the assertion of (13) is inappropriate. Now, these same judgments, I think, hold of the next sentence considered in the light of the same pair of scenarios.

(14) The troop of soldiers saw the band of Indians.

Third, I want to show that the human doxic capacity is responsible for ascertaining when properties, usually thought to be true only of individual objects, are true of collective objects. This point can be raised with regard to the preceding pair of sentences. But let me, instead, pick a new pair.

(15)

1. The man is left-handed.
2. The men are left-handed.

Left-handedness is a property of human bodies. This fact might mislead one into thinking that (15.2) has only one reading, a distributive one, and that the grammar must guarantee that (15.2) has only one reading. But does it have only one reading? Could it not have a collective reading? One might balk at such a suggestion on the grounds that it is odd to speak of a collective object as having the property of left-handedness. But if that were so, then, under the assumptions adopted so far, there would be no accounting for the unimpeachability of this sentence:

(16) The team is left-handed.

So the view adopted here is that plural count nouns are liable to an array of collective and distributive readings, that the conceptual capacity provides both collective and individual objects for semantic interpretation, that the doxic capacity provides the means of construing properties and relations which hold paradigmatically of individual objects as properties and relations which hold of collections of such individual objects, and finally that the speaker's knowledge of the world is responsible for making some readings of plural noun phrases more salient than others. Because of the importance of this view, let me illustrate it further with a number of examples whose import will not be brought to bear until later in the chapter.

Usually, the relation of knowing (in the sense of being personally familiar with) obtains between pairs of individual persons. Thus, there is nothing odd about this sentence.

(17) The American knows the Russian.

At the same time, though, it is perfectly consistent to say that

(18) The American team knows the Russian team.

But surely the American team would be said to know the Russian team because at least one member of the American team, insofar as he is a member of the team, knows at least one member of the Russian team, also insofar as he is a member of the Russian team; for one would be loathe to admit the logical compatibility of (18) with the following example:

(19) No member of the American team knows any member of the Russian team.

However, it should not be concluded from this that every relation ascribed to collective objects is based on some relation between individuals in the collective objects; for the next pair of sentences fail to have the incompatibility of the pair of (18) and (19).

(20)

1. The American team endorses the Russian team.

2. No member of the American team endorses any member of the Russian team.

Indeed, there is no logical incompatibility between (20.1) and this sentence.

- (21) No member of the American team endorses the Russian team.

That is, no member of the American team would endorse the Russian team, though the American team, as a collective body, does.

As a final example, let me adduce some sentences whose main verb is displace. Displace, in the sense of one thing taking the place of another, is believed to be a relation between individual objects. Moreover, it seems to be not only an entrenched common sense belief that two (distinct) things cannot occupy the same place at the same time, but a belief sanctioned by physics.

Hence, when one hears the sentence

- (22) The boy displaced the girl.

one believes that the space occupied by the girl comes to be occupied by the boy -- the girl going to a different location. In addition, it is hard to believe that one displaces two girls, seated, say, ten meters apart, for no one believes a boy (or anything of a suitable size) can occupy two places (of suitable size and distance apart) at the same time. And yet, it is perfectly grammatical, both syntactically and semantically, to

say:

(23) The boy displaced the girls.

Indeed, imagine the situation in which there are several girls and one boy. Each child has a seat, and there are only enough to go around. The teacher for these children orders the boy to take another seat, thereby having to deprive some girl of her seat. And if, further, each girl displaces the one next to her, until eventually the boy's vacated seat is occupied, then, under these circumstances, it is perfectly appropriate to say (23). In terms of one's beliefs about the real world, only one child displaces another. But the boy did not displace the girls one by one; rather, he displaced one girl who was so related to others that her displacement caused their displacement. In other words, the girls can be read collectively and the relation taken to hold between the boy and the girls insofar as the relation holds between the boy and one girl.

4.3 Simple Sentences Interpreted

Since the interpretation of the verb phrase is essentially like that of the simple sentence, I now turn directly to the interpretation of simple sentences. In light of the limitations, adopted earlier in the thesis, on which items are to be treated in the lexical categories of determiner and noun, there are

basically four cases to be considered: those which arise depending on whether the noun phrases are quantified or not, and those which arise depending on whether the verb is transitive or not. Cases of noun phrases without quantifiers are simpler than those with; and case of sentences with intransitive verbs are simpler than those with transitive ones. So the discussion below will proceed as follows: (i) a sentence with an intransitive verb and no quantified noun phrase, (ii) a sentence with a transitive verb and no quantified noun phrases, (iii) a sentence with an intransitive verb and a quantified noun phrase, and (iv) a sentence with a transitive verb and quantified noun phrases.

Intimately bound up with the interpretation of (simple) sentences is the problem of the provenience of collective and distributive readings of (simple) noun phrases. For this reason, I broach this problem at the outset of the treatment of the simplest case, a sentence with an intransitive verb and no quantified noun phrase. Consider this pair of examples.

(24)

1. The man rowed.
2. The men rowed.

It is clear that (24.1) can be handled by an interpretation in which the man is assigned an individual from the domain of

interpretation and row is assigned a one-place propositional function. Even if one adopts the principle for interpreting nouns given earlier, in which nouns are assigned subsets of the domain of interpretation, one can still assign row a propositional function, since the convention was adopted that singletons, which are assigned to singular nouns, are equivalent in semantic interpretation to their members. But such a move is not possible in (24.2); and it is for this reason that generalized propositional functions are defined over subsets of the domain of interpretation (not over individuals). (See (4) in 3.3 above.)

But generalized propositional functions also permit a natural and straightforward treatment of the problem of collective and distributive readings. To see this, one should consider an interpretation of (24.2) in some detail. Let the men denote a set, say

(25) {Rick, Randy, Rod}

Now, consider these situations.

(26)

1. Rick, Randy, and Rod were in one boat and rowed, each pulling an oar.
2. Rick and Randy were in one boat and rowed, each pulling an oar; while Rod was in another boat and rowed.

3. Rick and Rod were in one boat and rowed, each pulling on an oar; while Randy was in another boat and rowed.
4. Randy and Rod were in one boat and rowed, each pulling on an oar; while Rick was in another boat and rowed.
5. Rick was in one boat and rowed; Randy was in another boat and rowed; and Rod was in still another boat and rowed.

It is clear that each situation in (26) makes (24.2) true. Note that (26.1) and (26.5) correspond to the collective and distributive readings of (24.2) respectively. But note also that (26.2) through (26.4) are other readings which fall between the collective and distributive ones. In a sense which is to be made rigorous, (26.1) and (26.5) are bounds on the readings of (24.2). To show that in this case, associate with each of the situations in (26) a family of sets, each member being the set of people in a boat of the given situation. That is to say, the following families of subsets of the set denoted by the men are respectively associated with each situation in (26).

(27)

1. {{Rick, Randy, Rod}}
2. {{Rick, Randy}, {Rod}}
3. {{Rick, Rod}, {Randy}}
4. {{Randy, Rod}, {Rick}}
5. {{Rick}, {Randy}, {Rod}}

Careful consideration of (24.2) reveals that (26) does not provide one with all its readings. Surely, (24.2) is true in the following situation.

(28) Rick and Randy were in one boat and rowed, each pulling on an oar; and later Rick and Rod were in one boat and rowed, each pulling on an oar.

Here the associated set is this family:

(29)

1. {{Rick, Randy}, {Rick, Rod}}.

Indeed, situations like (28) corresponding to each of the families of sets below can be seen to make (24.2) true.

2. {{Rick, Rod}, {Randy, Rod}}

3. {{Rick, Randy}, {Rod, Randy}}

4. {{Rick, Rod}, {Rick, Randy}, {Randy, Rod}}

Now, each member of each family in (27) and (29) is a subset of the set consisting in Rick, Randy, and Rod (i.e., of (25) above). But the families of (27) and (29) are not all of the families of subsets from (25). For example, there is this family:

(30) {{Rick, Randy, Rod}, {Rick, Randy}}

Given such a set, could one conceive of a reading of (24.2) such

as the following?

- (31) Rick, Randy, and Rod are in one boat and rowed, each pulling on an oar; while later Rick and Randy were in one boat and rowed, each pulling on an oar.

But this is not a reading. To see this, suppose that it were. If only the situation of (26.1) obtained, then (24.2) would be false on the reading associated with (30). But this is not so. It seems then that once a sentence like (24.2) is true in virtue of a situation like (26.1), then it remains true no matter how the situation is enriched. Thus, subsets of (25) in addition to (25) itself in a family of sets are superfluous in the interpretation of (24.2). So, which families of subsets of (25) are the ones which provide the subsets of the domain of interpretation whereby (24.2) could be true?

The answer to this question requires the introduction of some technical terminology. First, there is the term "cover". A cover of a set is any family of non-empty subsets of the set to be covered each of whose elements, when taken together, constitute the set to be covered.<6> This can be stated more precisely.

- (32) Definition of Cover

Let Y be a set. Let $P(Y)$ be the power set of Y . X , a subset of $P(Y)$, covers Y if and only if
(1) $\cup X = Y$ and (2) $\emptyset \notin X$.

The families in (27) and (29) each cover (25). And so do the families in (30) and the following:

(33)

1. $\{\{Rick, Rod, Randy\}, \{Rick, Rod\}, \{Rick\}\}$
2. $\{\{Rick, Rod, Randy\}, \{Rick\}, \{Rod\}, \{Randy\}\}$

A special kind of cover (i.e., a set which covers another set) is a partition. It is a cover none of whose members have any elements in common.

(34) Definition of Partition

Let Y be a set and $P(Y)$ the power set of Y .
 X , a subset of $P(Y)$, is a partition of Y if and only if (1) X covers Y and (2) for all distinct pairs in X , x and y , $x \cap y = \emptyset$.

The families in (27) are partitions of (25). Now, the families pertinent to semantic interpretation are what I shall call "plurality covers". A plurality cover is a cover none of whose members are subsets of any of the others.

(35) Definition of Plurality Cover

Let Y be a set and $P(Y)$ be the power set of Y .
 X , a subset of $P(Y)$, is a plurality cover of Y if and only if (1) X covers Y and (2) for all distinct pairs in X , x and y , $x \not\subseteq y$.

The only plurality covers of (25) are those in (27) and (29). In

fact, the set of plurality covers of a set is a superset of the set of its partitions and a subset of the set of its covers.

The set of plurality covers of a given set embody a certain amount of structure which it is important to note in the present context. In particular, the set of plurality covers of a given set can be partially ordered, having within that order a maximal and a minimal element. Now a partial ordering relation is a relation which is reflexive, antisymmetric, and transitive. The relation which partially orders the set of plurality covers is the relation borne by one plurality cover to another when every member of the former plurality cover is a subset of some member of the latter plurality cover. I make this precise as follows:

(36) Definition of Subplurality Cover

Let Y be a set. Let $PC_1(Y)$ and $PC_2(Y)$ be plurality covers of Y . $PC_1(Y)$ is a subplurality cover of $PC_2(Y)$ if and only if for all $x \in PC_1(Y)$ there is some $y \in PC_2(Y)$ such that x is a subset of y .

Below is the partially ordered set diagram of the set of plurality covers of a set consisting of three distinct elements. (Compare (25) above and the sets in (27) and (29).)

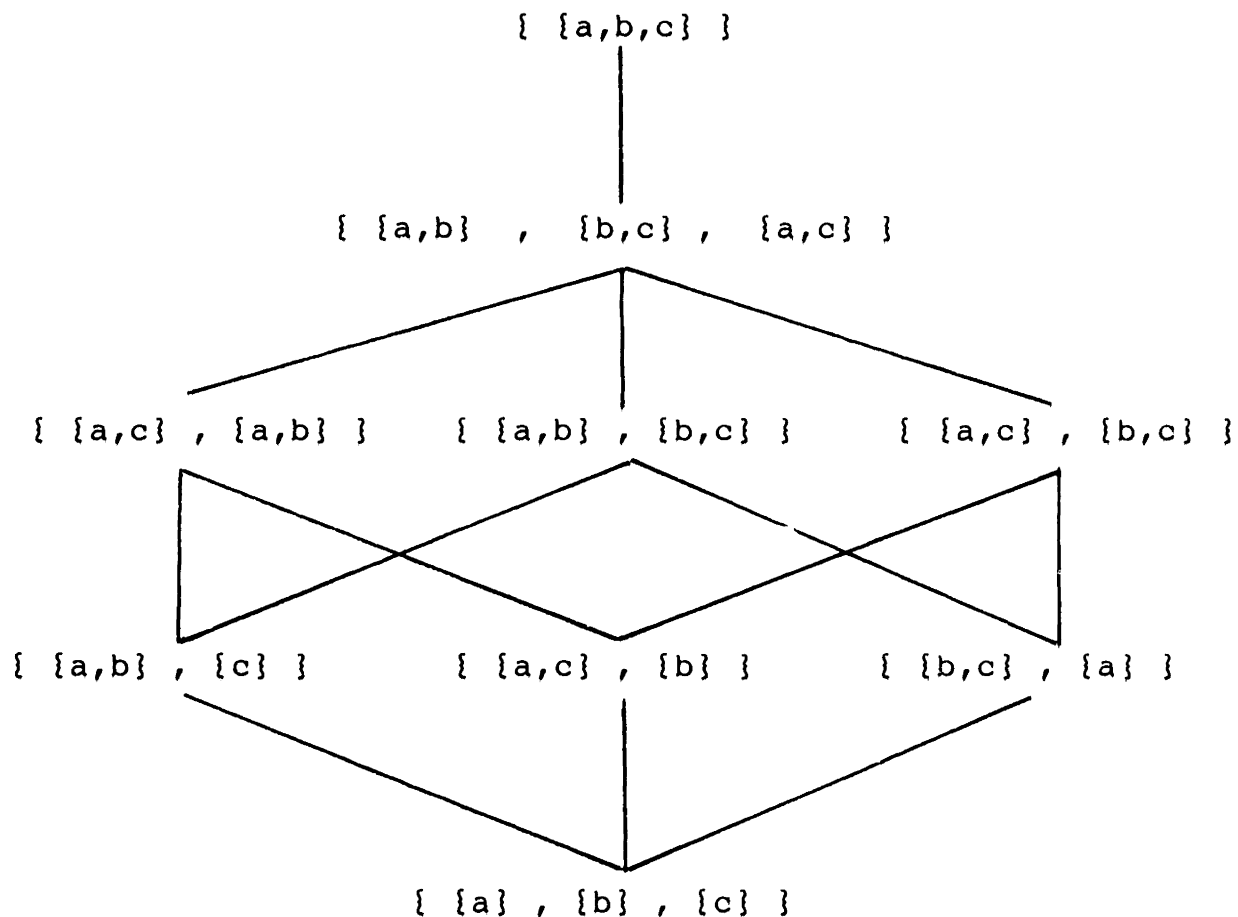

Figure 1

To see that the relation of being a subplurality cover is a partial ordering, one must see that it is reflexive, antisymmetric, and transitive. And it is to this task that I now turn. It is obvious that the relation is both reflexive and transitive, so I shall only set out a proof that it is

antisymmetric as well. If one plurality cover is a subplurality cover of another plurality cover and the second is a subplurality cover of the first, then the plurality covers are the same: in other words, the relation of being a subplurality cover is antisymmetric. Suppose that X and Y are subplurality covers of each other, but they are distinct. Then, because $X \neq Y$, there is some member of X , say x_1 , which is distinct from every member of Y . But x_1 is a subset of some set in Y , say y_1 , since X is a subplurality cover of Y . Therefore x_1 is a proper subset of y_1 . But y_1 is a subset of some set in X . This set cannot be x_1 , since x_1 is a proper subset of y_1 . So let this set be x_2 . But x_1 is a subset of x_2 , since x_1 is a subset of y_1 and y_1 is a subset of x_2 . But then X would not be a plurality cover, since it contains two distinct sets, x_1 and x_2 , such that one (x_1) is a subset of the other (x_2). The relation of being a subplurality cover is, therefore, antisymmetric. And so, I have shown that the relation is a partial order.

Finally, I wish to show that the plurality cover of a set which contains just the set itself is the maximal element of all the plurality covers of the set, and that the plurality cover which contains just singletons of each element member of the set covered is the minimal element of all the plurality covers of the set covered. Now, an element is a maximal element in a set of

partially ordered elements just in case every element in the partially ordered set bears the partial ordering relation to it. It should be clear that every plurality cover of a set X is a subplurality cover of the plurality cover $\{X\}$, for the members of any plurality cover of X are each subsets of X . Hence, for any plurality cover of X , every member of that plurality cover is a subset of X , hence that plurality cover is a subplurality cover of $\{X\}$. So $\{X\}$ is a maximal plurality cover of X . Next, consider the family which consists in all the singletons for each member of X . Call such a family Y . Y is a plurality cover of X and Y is a subplurality cover of every plurality cover of X . For let Z be a plurality cover of X , and let $\{y\}$ be a member of Y . If, $\{y\}$ is not a subset of any member of Z , then it is not a subset of the union of all the members of Z . In that case, y is not a member of such a union. But then the union does not cover X , since y is a member of X but not a member of the union of the elements of Z . Hence, Z does not cover X . But Z is a plurality cover of X . So the supposition that $\{y\}$ is not a subset of any member of Z is false. Hence, Y is a subplurality cover of every plurality cover of X , and so is the minimal plurality cover in the set of plurality covers (of X).

To sum up, then, one should observe that the set of plurality covers of a given set is a partially ordered set under

the relation of being a subplurality cover, whose greatest element is the plurality cover containing just the given set and whose least element is the plurality cover containing all and only the singletons of each element in the given set.

I began this section considering the collective and distributive readings of a simple sentence with an intransitive verb. Let me now consider one with a transitive verb.

(37) The men endorsed the women.

Suppose the men denotes Rick and Randy and the women denotes Diane and Lillian. Below are given the plurality coverings of the two doubletons, and below them, eight directed bipartite graphs are given, each depicting one of the readings of (37).

(38)

$M_1 : \{\{\text{Rick}, \text{Randy}\}\}$ $M_2 : \{\{\text{Rick}\}, \{\text{Randy}\}\}$	$W_1 : \{\{\text{Diane}, \text{Lillian}\}\}$ $W_2 : \{\{\text{Diane}\}, \{\text{Lillian}\}\}$
--	--

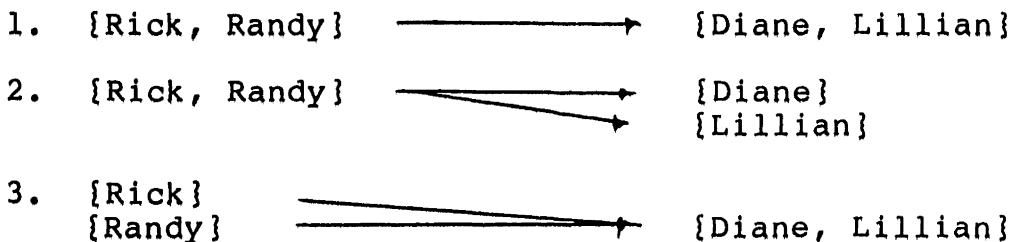

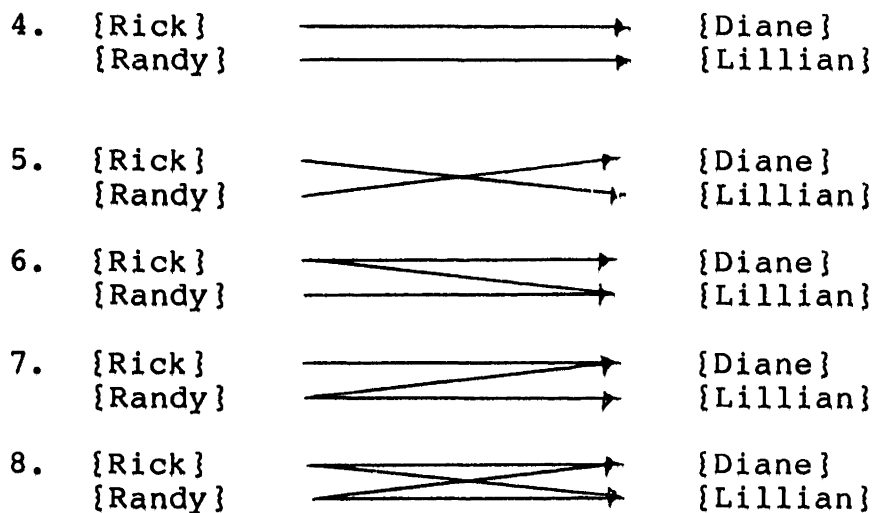

Figure 2

In general, then, how many readings (i.e., distinct ways to be true) are there for a simple sentence with a transitive verb? Let n be the number of plurality covers of the subject noun phrase and let M_i ($1 \leq i \leq n$) be one of its plurality covers. Let m be the number of plurality covers of the object noun phrase and let W_j ($1 \leq j \leq m$) be one of its plurality covers. Then the total number of readings is the sum of the number of bipartite directed graphs from members of M_i to members of W_j such that each member of M_i has a directed arc to some member of W_j and each member of W_j has a directed arc to it from some member in M_i .

I now come to the cases of simple sentences with quantified

(simple) noun phrases. Naturally, I begin with the case where the verb is intransitive. Examples of such a case are given below.

(39)

1. Some man rowed.
2. Each man rowed.
3. Some men rowed.
4. All men rowed.

To see how these sentences are to be interpreted, one needs to know the form of the phrase marker at LF, how the principles of interpretation apply to the phrase marker (in particular, the principles of interpretation for quantifiers), and what import the singularity or plurality of the noun phrase has (in particular, what import they have for the quantifiers in the noun phrases in which they occur).

I shall address each of these points in turn. First, there is the matter of the phrase marker at LF. One saw in the first chapter that phrase markers at LF are derived, in the non-trivial case, from phrase markers at SS by the rule QR. Now the phrase marker of each sentence in (39) at SS is identical to its phrase marker at DS. I give the phrase markers of all the sentences in (39) at SS as one below:

(40)

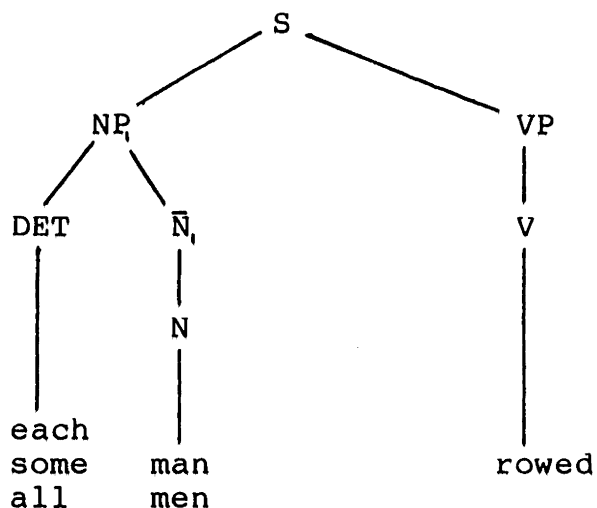

QR triggered by the quantifier in NP of (40) generates the following phrase markers at LF for the sentences in (39).

(41)

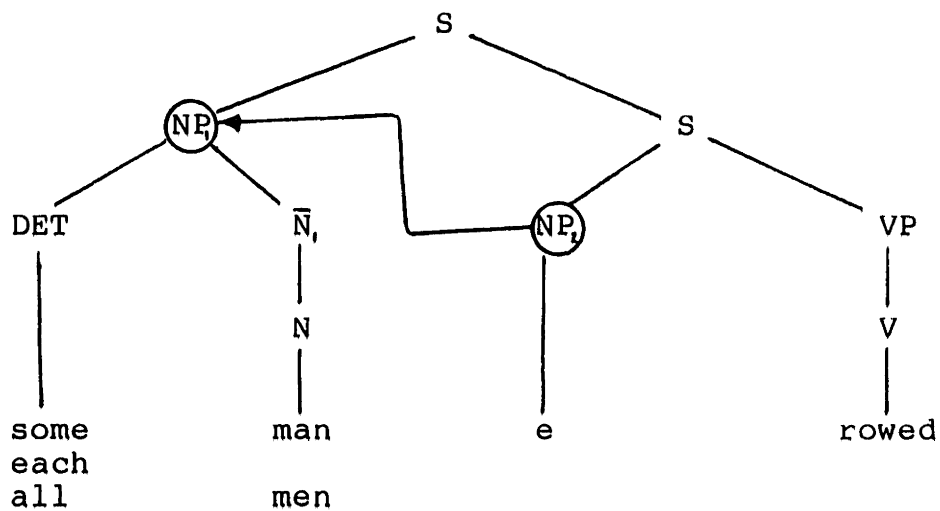

Recall that QR is a movement rule and movement creates links. In these cases, NP_2 is linked to NP_1 . So NP_1 binds NP_2 and NP_2 and NP_1 have the same features. In (39.1) and (39.2), NP has the

feature -PL; but in (39.3) and (39.4), NP has the feature +PL. Second, I maintained in chapter three that quantifiers are interpreted as two-place functions. The first place of the function (Q^0) takes values in the power set of the domain of interpretation; the second place of the function (Q^0) takes values in the set of n-place generalized propositional functions; and Q^0 yields values in the set of n-1 place propositional functions. More specifically, the first place of Q^0 takes as values any plurality cover of the set which is the extension of the balance of the noun phrase in which it occurs. In a simple noun phrase the values are any plurality cover of \bar{N}^0 . If the quantified noun phrase has the feature -PL, the plurality cover is the minimal one, that is, the one which consists in singletons of the members of the set covered. If the quantified noun phrase has the feature +PL, then the plurality cover is any one which does not contain a singleton member. The upshot, then, is that the NP node of a quantified noun phrase is interpreted as a one-place function mapping n-place generalized propositional functions into n-1 place generalized propositional functions. This function, QNP^0 , takes the generalized propositional function assigned to its sister S node as a value.<7>

The foregoing can be applied to the sentences in (39) in terms of their phrase markers in (41). Let the domain of

interpretation be the set consisting in Rick, Randy, and Rod ((25) above.) Let man denote this set. The nine plurality covers which can be associated with this set are given in (27) and (29) above. In the case of (39.1) and (39.2), the function assigned to the quantifier, Q^0 , takes the minimal plurality cover (27.5) as the value of its first place: $\{\{Rick\}, \{Randy\}, \{Rod\}\}$. In the case of (39.3) and (39.4), it takes as values members of plurality covers with no singletons: (27.1), (29.1)-(29.3). Next, rowed is interpreted as a one-place generalized propositional function. Since there are no nodes distinct from the nodes dominated by S_2 in the path from the node V to the node S_2 to which a value is assigned, $S_2^0 = V^0$, that is, the generalized propositional function assigned to rowed. Finally, the NP_1 node binds the NP_2 node which, in turn, is the argument position to which the argument place of row is assigned. So the interpretation of S_1 depends on NP_1^0 and S_2^0 : it is the zero place generalized propositional function, that is, one of the Boolean values 1 or 0, yielded when NP_1^0 takes S_2^0 as a value.

So, in example (38.1), the value is 1 just in case some singleton in the minimal plurality cover of the set (24) rowed. In example (38.2), the value is 1 just in case each such singleton rowed. In the last two examples, (38.3) and (38.4),

the value is 1, just in case some and every set in a plurality cover with no singletons rowed (respectively).

4.3.1 Simple Sentences with Reciprocal Pronoun Interpreted

The interpretation of simple sentences with transitive verbs and quantified noun phrases is a straightforward extension of the previous case. I shall close this chapter, showing how the principles of interpretation adduced so far provide a straightforward and intuitively satisfying account of the semantic interpretation of the reciprocal pronoun. Now, there is only one possible configuration, at SS, for phrase markers of simple sentences with reciprocal pronouns. This configuration is given below.

(42)

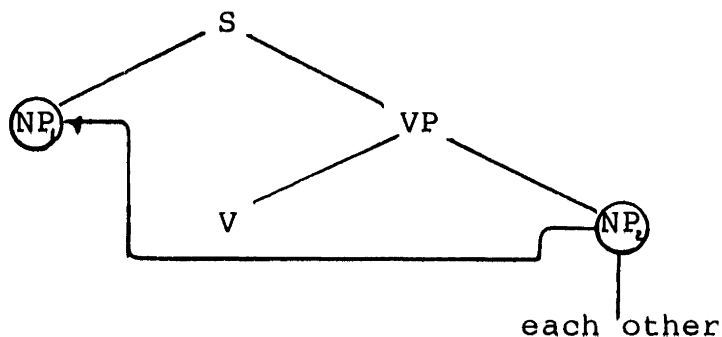

If a simple sentence contains no quantifiers, (42) is also the configuration of the simple sentence's phrase marker at LF. I

shall first confine my discussion to cases where NP_1 is not quantified. Now, the fact that NP_2 is linked to NP_1 means that each is assigned the same interpretation. But, this linking in the case of a reciprocal pronoun means something more, namely, that the reciprocal relation is to be defined on the same plurality covering, and, in particular, a partition. In other words, reciprocal pronouns do exactly what they purport to do: to help express reciprocal relations. But these relations are not defined on the set assigned to the antecedent of the pronoun, but on a partition of the set, which, as was noted, is a plurality covering of the set. The result of this shift in the locus of the definition of the relation is that all the sentences involving reciprocal pronouns fall to one principle of interpretation, namely,

(43)

Principle of Interpretation for Reciprocal Pronouns<8>

Consider a phrase marker at LF in which the noun phrase node NP_2 dominating a reciprocal pronoun has NP_1 as an antecedent. The values assumed by NP_1 and NP_2 when evaluated with respect to the function interpreting the predicate (of which NP_1 and NP_2 are argument positions) are distinct members of a partition of NP_1^0 .

To show that this is so, I shall consider a few examples. First, there is the example used to show that defining reciprocity over all non-identical pairs of the relevant set is

inadequate.

(44) Her grandparents hate each other.

As has been often pointed out, this sentence may be true even if the reciprocal hatred is only between the maternal grandparents on the one hand and the paternal ones on the other. But this is to imply reciprocity defined over a partition of the grandparents. Second, there are sentences where the reciprocal pronoun seems to help to express a cyclic relation. This is exemplified by the fact that the following sentence is made true by a situation in which the children are playing musical chairs but with enough chairs to go around and with everyone finding a seat.

(45) The children displaced one another.

In such a situation, what is being expressed is that one member of a bipartite partition of the children is displacing the other member, and vice versa. Further confirmation of this treatment of reflexive and reciprocal pronouns is forthcoming from two pairs of interesting sentences discussed by Lauri Carlson (1982: Part I, Sect. 9).

(46)

1. The men pulled themselves up.
2. The men pulled each other up.

(47)

1. The men killed themselves.
2. The men killed each other.

Carlson maintains that these sentences are true in the following circumstances. The first pair is true in the circumstances in which two window washers, who are standing on a window washing platform, pull on ropes on opposite sides of the platform thereby raising the platform. The second pair is true in the event that two men agree to drive their automobiles at each other, intending and succeeding in the death of each. Now these judgments, which I share, fall to the interpretation of reciprocal pronouns which I am proposing. With regard to the first sentence in each pair, the plurality cover is the set containing the pair of men. With regard to the second sentence in each pair, the plurality cover is the partition which is the pair of singletons.

To conclude this treatment of the interpretation of the reciprocal pronoun, I point out that nothing special need be said to handle cases where the antecedent of the reciprocal pronoun is a quantified noun phrase.<9>

(48)

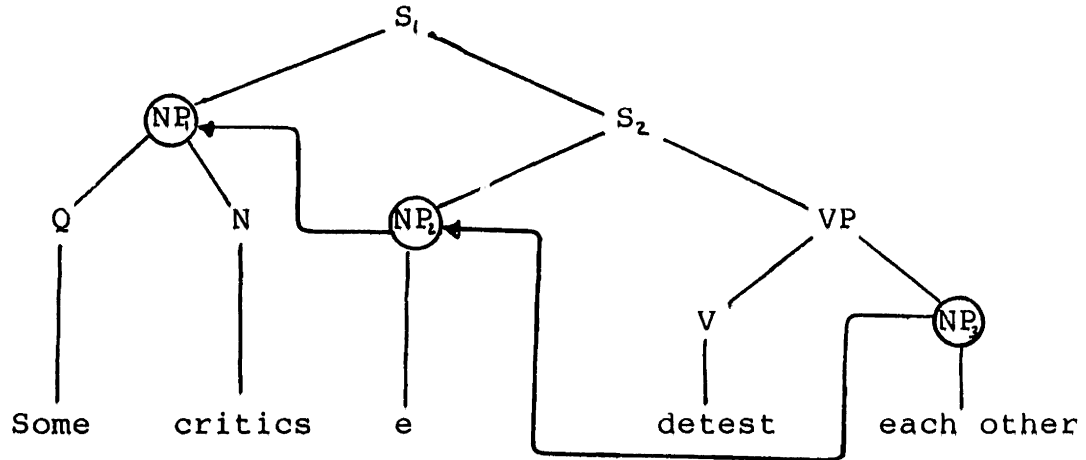

NP_3 is linked to NP_2 at SS (to meet condition (11) in 3.2.2 above) and NP_2 is linked to NP_1 through movement. Since NP_1 is a quantifier, it binds NP_2 . And since NP_2 has the feature +PL, the plurality cover which serves as the restricted domain of the quantifier some may contain no singletons (as was shown in 4.3 above). Hence, the two place function interpreting S can acquire its pairs of distinct values on some particular of the non-singletons furnished by the quantifier.

FOOTNOTES· CHAPTER FOUR

1. There is a use of the plural which is anomalous. Consider the following sentence in the context where someone is being disabused of the mistaken belief that Samuel Clemens and Mark Twain are different persons.

(i) These men are the same person.

Clearly the denotation of the noun phrase these men does not have a cardinality exceeding one.

2. This is an observation attributed to Hans Kamp by Lauri Carlson (1982: Part I, Sect. 2).
3. I owe this pair of examples to Rick Lathrop.
4. This observation is due Carlson (1982: Part I, Sect. 4 and 10).
5. Some definitions of "cover" do not exclude the empty set.
6. Remember that QR adjoins a QNP to an S node in such a way that each QNP, once moved, has an S node for a sister node.
7. This is essentially what is given by Higginbotham (1981). Notice that this principle is not a rule of truth.
8. This example was brought to my attention by Jim Higginbotham.

CHAPTER FIVE

THE SEMANTICS OF LESS SIMPLE SENTENCES

5.0 Introduction

In this chapter, I shall extend the results of the previous chapters to sentences more complex than simple ones. This extension serves two purposes: it lends substantiation to the results of the earlier chapters by showing their generality, and it paves the way for the examination in the next chapter of the claim made by Hintikka that there are sentences in natural language, and in particular English, whose semantic interpretation is properly represented only by branching quantifiers.

In what way are the sentences to be treated here more complex than those treated in the previous chapter? They are more complex in that the verb phrase or the noun phrase is more complex. In the case of the verb phrase, the complexity accrues to the admission into it of what I shall argue are adverbial modifiers. Here, what will be looked at are the so-called "Q-float phenomena". In the case of the noun phrase, the complexity accrues to the admission into it of conjunction, adjectives and prepositional phrases. More specifically, I shall

be examining sentences whose noun phrases consist either in a pair of conjoined simple noun phrases, or in a simple noun phrase with an adjectival modifier, or in a simple noun phrase with a prepositional phrase. I shall begin with the Q-float phenomena.

5.1 Q-Float

Both, all, and each, I claimed in the previous chapter, are quantifiers. Quantifiers, in that chapter, are a kind of determiner. Hence, these three words are determiners. Now no one disagrees that determiners occur at the beginning of noun phrases. But some sentences have both, all, or each in a position which is not the beginning of a noun phrase. Here are some examples.

(1)

1. The men all left.
2. The senators each resigned.
3. We both were arrested.
4. Harry saw them all.

Fiengo and Lasnik (1973: 447) attribute the observation and a treatment of such cases to Postal in his classes of 1971. The treatment, one gathers, is that such cases are derived by transformation from the usual configuration of [_{NP} DET N]. Sentences which are the same as the ones in (1) except that their

derivational history does not contain this postulated transformation would be these.

(2)

1. All of the men left.
2. Each of the senators resigned.
3. Both of us were arrested.
4. Harry saw all of them.

Subsequently, Postal (1974: Chapter 4, Sect. 5) draws attention to a disparity between cases where the noun in the underlying configuration is a pronoun and cases where it is not.

(3)

1. They all, it seems to me, have the same outlook.
2. ?*The visitors all, it seems to me, have the same outlook.
3. They, it seems to me, all have the same outlook.
4. The visitors, it seems to me, all have the same outlook.

According to Postal, once the quantifier is floated, so to speak -- in this case, postposed -- it has the option of forming a constituent with the preceding noun, only if it is a pronoun, and otherwise not. Postal, then, adopts the following structural analysis for the sentences They all left and The men all left.

(4)

1. [They all] left.

2. [They] all left.
3. *[The men all] left.
4. [The men] all left.

Even if the judgments in (3) and (4) are correct, the analysis, as it stands, leads to unequivocally incorrect results.<1> This is pointed out by Maling (1976: 711).

(5)

1. I like them all.
2. *I like the men all.

She suggests an alternative analysis based on the array of data in Table 1.

all of the men	all the men	*the men all<2>
both of the men	both the men	*the men both<2>
each of the men	*each the men	*the men each<2>
Q of the men	*Q the men	*the men Q
all of them	*all they/them	they/them all
both of them	*both they/them	they/them both
each of them	*each they/them	*they/them each
Q of them	*Q they/them	*they/them Q

Table 1

(Q is any quantifier other than all, both, or each.) She maintains that all and both are subject to a minor transformation in which the preposition of is deleted.

(6)

1. all of the men -----> all the men
2. both of the men -----> both the men
3. each of the men -----> *each the men
4. Q of the men -----> *Q the men

She also notes that such a transformation, when freely applied, yields incorrect results, if the noun in the prepositional phrase is a pronoun.

(7)

1. all of them -----> *all they/them
2. both of them -----> *both they/them
3. each of them -----> *each they/them
4. Q of them -----> *Q of they/them

However, pronouns do permit all and both to occur after them.

(8)

1. all of them -----> they/them all
2. both of them -----> they/them both
3. each of them -----> *they/them each <2>
4. Q of them -----> *they/them Q

In short, both and all find themselves before a noun, if it is not a pronoun, and after it, if it is one. Maling proposes,

then, that the deletion of the preposition of is optional, but if it results in a sequence of all or both and a pronoun then the sequence must be inverted. This pair of minor transformations, she holds, and Q-float together account for the occurrence of these three determiners in positions other than at the beginning of a noun phrase.

There are several considerations accruing from the linguistic theory adopted in this thesis which militate against any analysis of these cases as ones which result from movement in the syntax, that is, which result from mappings from DS to SS or from SS to LF. To see this, one need only reflect on sentences which clearly do not involve the so-called minor transformations and so only involve Q-float. Such sentences are just like those in (1), except the verb is paraphrastic and the word each, both, or all occurs between the auxiliary and main verb.

(9)

1. The men will all leave.
2. The senators have each resigned.
3. We were both arrested.

Now, were the occurrences of both, all and each to result from a transformation like Q-float, the transformation would be an utter

anomaly with respect to application of the rule move . First, movement in syntax typically applies to a uniform syntactic class. In the case of NP-movement, a noun phrase is moved, since otherwise it would not receive case. In the case of WH-movement, a noun phrase with a WH feature is moved in virtue of the fact that it has that feature. And in the case of Q-movement, a quantified noun phrase is moved in virtue of the fact that the noun phrase contains a quantifier. Q-float, in contrast, applies to just three of the quantifiers.<3>

(10)

1. *The men will some leave.
2. *The senators have none resigned.
3. *We were every arrested.

Second, the typical instances of move result in a whole phrase being moved; but Q-float results in only a lexical item being moved. Third, the positions to which phrases are moved by NP-movement, WH-movement, or Q-movement are uniquely characterizable. NP-movement moves a noun phrase to an argument position which is not theta-marked; WH-movement moves a noun phrase with a WH feature to COMP; and Q-movement moves a quantified noun phrase to a position adjoined to S. In contrast, Q-float does not move items to any uniquely characterizable position.

Abandoning a transformational account of the provenience of these configurations involving each, both and all, one might be tempted to invoke rules in the base as the source. But this will not do. Presumably, lexical items are freely inserted under the lexical nodes generated by the base. The question arises why quantifiers other than each, both and all cannot be inserted in the positions into which these three are inserted, as in (10) above or in the following example:

(11)

1. *The men some leave.
2. *The senators none resigned.
3. *We every were arrested.

Notice, however, that the positions in (1) and (9) in which each, both and all occurs are positions in which adverbs occur.

(12)

1. The men discretely leave.
2. The senators quietly resigned.
3. We frequently were arrested.

(13)

1. The men will discretely leave.
2. The senators have quietly resigned.

3. We were frequently arrested.

In light of this fact, I suggest that these three words have dual lexical entries, one as determiner and one as adverb.

This suggestion does not encompass the cases which fall under the purview of Maling's so-called minor transformations. However, within the linguistic theory adopted here, these minor transformations find their place, not in the mapping from DS to SS, but in the mapping from SS to PF. That is to say, the configurations handled by these so-called minor transformations are not syntactic, but phonological configurations idiosyncratic to all and both. This, then, bears out the claim of the previous chapter that determiners do not iterate, though phonological idiosyncracies of all and both, triggered in the mapping from SS to PF, create the illusion that all and both are exceptions to the claim.

For the sake of thoroughness, I should mention that there are occurrences of each, both, and all in positions other than the ones discussed above. These cases involve sentences of a complexity beyond those to be treated at in this thesis. Each, both, or all may occur with an indirect object in the double object construction (Maling 1976: 715-717).

(14)

1. I gave the kids all some candy.
2. *I gave some candy to the kids all.

(15)

1. The tooth fairy promised the kids each a quarter.
2. *The tooth fairy promised a quarter to the kids each.

(16)

1. Dad bought the boys both bicycles.
2. *Dad bought bicycles for the boys both.

In addition, each, all, or both may occur at the beginning of small clauses.

(17)

1. Mom found the boys both dirty.
2. We consider the Joneses all unbearably pompous.
3. The negotiator regards the parties as each an obstacle to peace.

Finally, each of these three words may occur at the beginning of prepositional phrases.

(18)

1. He looked the twins both in the eye.
2. The godmother turned the pumpkins all into handsome coaches.
3. She let the men each into the room.

The expectation is that these cases too will yield to an adverbial account; but I shall make no attempt to spell out such an account here.

I now turn to a semantic account of these three words insofar as they have been analyzed above. Nothing special has to be said about the construction where there is the phonological deletion of the preposition of, or where the noun is a pronoun and they have been postposed. As far as the structure at LF is concerned, the configuration for interpretation is still [_{NP} [_N all] [_{PP} of ...]] or [_{NP} [_N both] [_{PP} of ...]]; for recall that the alterations are phonological and not syntactic. The interpretation of these phrases is that of a partitive. At the same time, something special does need to be said for their occurrences as adverbs.

I maintained in the last chapter that verbs are interpreted as generalized propositional functions. The function takes values in some plurality cover of the set denoted by the main phrase in an argument position of the node to which the function

is assigned. The adverbs all, both, and each restrict the interpretation of the function interpreting the verb by restricting the kinds of sets it can take as values. All prohibits the function from taking singleton sets as values; each requires the function to take singleton sets as values. Both prohibits the function from taking singleton sets as values, but requires that the set covered has a cardinality of two. Reflection on a few examples will bear this interpretation out.

(19) The men all rowed.

This is true just in case every non-singleton set in some plurality cover of the set denoted by the men rowed. In particular, (19) can express the fact that a team of men were involved in a co-operative effort to row a boat.

(20) The men each rowed.

This is true if each singleton in the minimal plurality cover of the set denoted by the subject rowed. Note that whereas the collective interpretation permits a distributive construal, the distributive interpretation does not permit a collective construal. This asymmetry as to what construal the semantic interpretations are liable, it was argued in the previous chapter, is a fact about how humans conceive collective objects

and about how beliefs determine the relation which properties thought to hold of a collective object bear to objects in the collection. Finally,

(21) The men both rowed,

is true, just in case a doubleton of men is denoted by the men and they rowed.

Let me now turn to the interaction of the adverbs each, both and all with anaphoric pronouns. Consider first the cases where the anaphoric pronoun is reflexive.

(22)

1. The contestants each admire themselves.
2. The contestants both admire themselves.
3. The contestants all admire themselves.

As I stated above, the adverbs in their interpretation, force the function assigned to the verb to select a plurality cover of the set denoted by the subject noun phrase. Of course the denotation assigned to the position of the reflexive pronoun must be the same as that assigned to its antecedent, but the plurality covers associated with each position need not be the same. This is borne out by the availability of readings consistent with restrictions on the plurality covers. For example, (18.1) is true, even if each contestant fails to admire himself, but

admires only the group of which he is a member; and (18.3) is true, even if no contestant admires the group of which he is a member, and admires only himself.

Coming to the cases where the anaphoric pronoun is reciprocal, one finds the situation is no longer so simple. This is because there are now two conditions on the interpretation of the verb, one due to the reciprocal pronoun and one due to the adverb. That is to say, the reciprocal pronoun has the requirement that it and its antecedent be interpreted with respect to the same plurality cover (see (45) in 4.3.1 above); while the adverb specifies the kind of set on which the function assigned to the verb may compute.

(23)

1. *The contestants each endorsed one another.
2. The contestants both endorsed each other.
3. The contestants all endorsed one another.

In (23.1), the conditions which must be met for the interpretation of the reciprocal pronoun are pre-empted by the conditions placed on the interpretation by the adverb. The adverb each requires that the function assigned to the verb take singletons as values; but encoded into the same function through the interpretation of the reciprocal pronoun is the requirement

that the function take as values sets which can be partitioned into at least two distinct sets. Singletons, though, cannot be so partitioned. Such a conflict cannot arise for (23.2) and (23.3) since the adverbs require the function assigned to the verb to take non-singletons as values, and every non-singleton can be partitioned into at least two distinct sets.

There is a curiosity pertaining to the interpretation of (23.3). The adverb all, I said, requires the function assigned to the verb to take non-singletons as values; the reciprocal pronoun requires that the values be partitionable into at least two distinct sets. Yet the interpretation of sentences like (23.3) is that the partition is atomic (i.e., the partition is into singletons). The question arises: why should not an interpretation with a non-atomic partition be available? Perhaps the answer is that the adverb requires the function assigned to the verb to take its values in the maximal plurality cover, instead of in any plurality cover containing no singletons. The maximal plurality cover contains only one set, namely the set covered. What has been observed so far is that the choice of plurality cover is free, unless overtly constrained by a quantifying determiner or adverb. This means that, unless overtly constrained, the choice of plurality cover is open to extra-semantic determination. Quantifying determiners and

adverbs introduce constraints and preclude extra-semantic determination of the plurality cover. So, when the reciprocal pronoun required a partition of the sole set in the maximal plurality cover, there is no extra-semantically determined partition to adopt and so the function takes a default value of the atomic partition.

Let me pursue this analysis in terms of sentences formed from simple ones by replacing the subject noun phrase with one consisting in a pair of conjoined simple ones. Such a sentence is the one below.

(24) The man and the woman are rowing.

To begin with, one can ask: which syntactic feature, +PL or -PL, does the subject noun phrase have? The answer comes from the fact that verbs agree with their subjects in number; in other words, the form of the verb is sensitive to the syntactic feature +PL of its subject noun phrase. In the example above, the subject noun phrase is a conjunction of two noun phrases each of which has the syntactic feature -PL. Clearly the syntactic feature +PL of the subject is a function of the noun phrase as a conjunction. Notice that this feature assignment is independent of whether or not the constituent noun phrases have count or mass nouns as heads.

(25)

1. The gold and the water are on the counter.
2. Gold and water are on the counter.

The pertinent syntactic principle is this:

(26) Principle of Syntactic Plurality in Conjoined Noun Phrases

If NP_1 consists in the conjunction of two or more NP's, then NP_1 is assigned the syntactic feature +PL.

This principle sheds light on the judgments of the following examples.

(27)

1. *Chunka and Sho respect himself.
2. Chunka and Sho respect themselves.

These sentences have the same structure at SS.

(28)

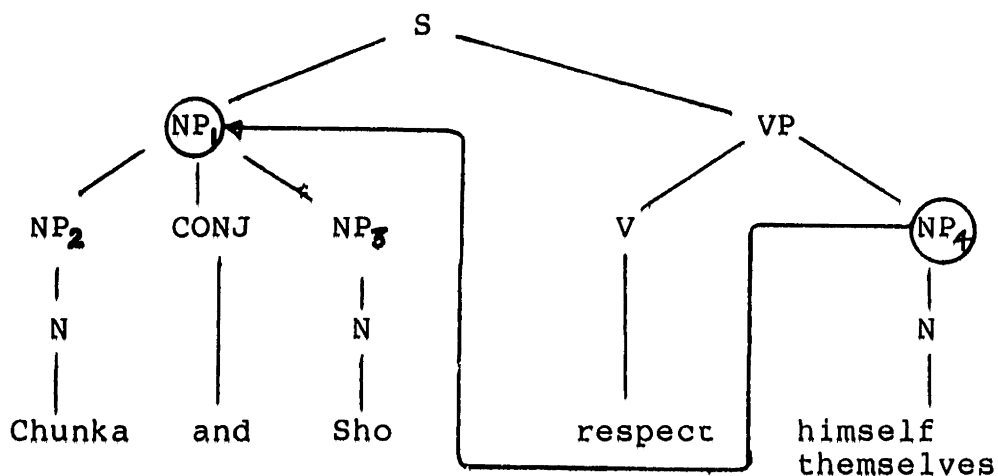

In the case of (27.1), there are only three noun phrases other than the one containing the reflexive pronoun. NP_1 , though it c-commands NP_4 , cannot be the antecedent of NP_4 , since NP_4 has the feature -PL and NP_1 has, in accordance with (26) above, the feature +PL. But, it was observed in a previous chapter, a noun phrase and its antecedent must have the same syntactic feature. (See (9.2) in 3.2.2 above.) Hence, one has an account for the ungrammaticality of (27.1). In the case of (27.2), the disparity in syntactic features between NP_2 and NP_4 and between NP_3 and NP_4 as well as the fact that neither NP_2 nor NP_3 c-commands NP_4 eliminates them from being antecedents of NP_4 . However, NP_1 c-commands NP_4 and its syntactic features agree with those of NP_4 , so that NP_1 may, and indeed must, be NP_4 's antecedent.

Turning from the reflexive to the reciprocal pronoun, one sees exactly what the structure and interpretation of the next sentence are.

(29) Chunka and Sho respect each other.

(30)

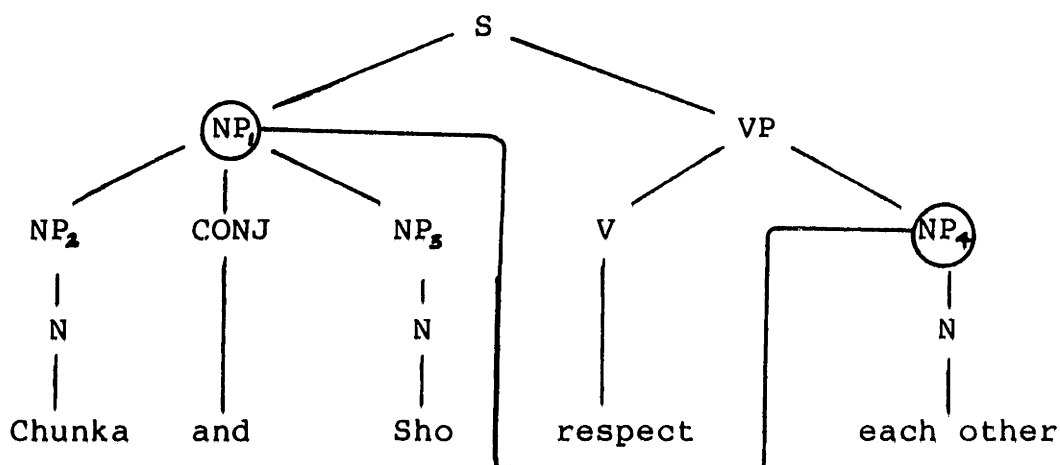

There is, of course, only one plurality cover of the set {Chunka, Sho} which forms a partition with at least two distinct elements, namely, {{Chunka}, {Sho}}. As one should expect, the adverbial modification by both of the verb in sentence (29) is acceptable.

(31) Chunka and Sho both respect each other.

The next sentence also has the structure which (29) has at SS.

(32) The men and the women admire each other.

Now (29) permits only one interpretation, since the interpretation of its NP₁ node must have a cardinality of two; (32) permits many interpretations. One reading which is made salient by the conjunction in NP₁, is one where the reciprocal

relation is defined over the pair in the binary partition of the set denoted by the men and the women, namely, the pair consisting in the set denoted by the men and the set denoted by the women. The grammar has a device by which to make this reading explicit.

(33) The men and the women both admire each other.

The only interpretation of (33) is that the men admire the women and the women admire the men. The adverb both, which requires that the subject noun phrase denote a set of cardinality of two, thereby insures that the men and the women are each collectively interpreted, that is, each denotes a collective object. Another interpretation available to (32) is the one in which the reciprocal relation is defined over every pair of members taken from the union of the sets denoted by the men and the women. The grammar also, as was seen earlier, has a device by which to make this reading explicit.

(34) The men and the women all admire one another.

In light of these results, one sees forthcoming further confirmation of the view held here, namely, that plural noun phrases are evaluated, as arguments, with respect to some plurality cover, the selection of which is constrained by extra-grammatical considerations. Consider a sentence discussed

by Langendoen (1978: 182):

(35) The men and the woman flirted with one another.

The interpretation ascribed to it is that the men flirted with the woman and she with the men. Of course, this is one interpretation, the analysis of which is essentially that of (32), except one element in the binary partition of the set denoted by the men and the woman is a singleton, namely, the singleton denoted by the woman. The interpretation is favored not only by the syntax, since the conjunction and makes salient this partition, but also by cultural attitudes, since non-heterosexual behavior is not usually expected. This reading can, of course, be made explicit.

(36) The men and the woman both flirted with each other.

However, there is the reading with the flirting taking place between each distinct pair in the set denoted by union of the set denoted by the men and the set denoted by the woman. This reading can be made explicit too.

(37) The men and the woman all flirted with one another.

5.2 The Noun Phrase Revisited

I turn from the analysis of the so-called Q-float phenomena to one of various enrichments of the simple noun phrase. In particular, I shall discuss noun phrases in which a simple noun phrase is augmented by an adjective preceding the noun or by a single prepositional phrase following the noun, the prepositional phrase consisting of the preposition of and a simple noun phrase. Examples of such noun phrases are these.

(38)

1. [_{NP} the [_{AP} long] march
2. [_{NP} this [_{AP} nuclear] explosion]
3. [_{NP} any governor [_{PP} of a state]]
4. [_{NP} the queen [_{PP} of Bhutan]]

Little has been done within the linguistic framework adopted in this thesis on the semantic interpretation of adjectives, and work on the structure and interpretation of prepositional phrases is still in its inception. The semantic analysis presented below is intended to be suggestive, not comprehensive.

5.2.1 Simple Noun Phrase with Prenominal Adjective Interpreted

As usual in this thesis, the treatment of semantics begins with an analysis of syntax. Adjectives may occur in a number of positions in a phrase marker.

(39)

1. The poem is [_{AP} long].
2. The apples were picked [_{AP} ripe].
3. The house [_{AP} ablaze] is next door.
4. A [_{AP} long] march took place in China.

Even within a noun phrase, as the examples above show, adjectives may occur before or after the noun. The interest here is adjectives in a noun phrase which precede the noun. Such adjectives received some attention in the second chapter (i.e., in 2.1.1) where prenominal adjectives were distinguished from determiners. I pointed out there that such adjectives were of a heterogeneous mix, including cardinality adjectives, predicating adjectives, and thematic adjectives. Although the semantic interpretation of adjectives must be sensitive to the differences among these types of adjectives, nonetheless they can all be interpreted by the same formal device. I shall concentrate only on the application of this formal device to predicating adjectives; but that it can be applied to the other types of adjectives is obvious.

Clearly adjectives take arguments. That is to say, a lexical entry for an adjective specifies that it has an argument. More specifically, I suggest that an adjective, like a verb, has a distinguished argument place, but unlike a verb, it

may not have any undistinguished argument places. This receives some substantiation from the fact that the complements of adjectives are never simple noun phrases but are rather prepositional phrases.

(40)

1. *proud Satish
2. proud of Satish

I suggest further that an adjective, like a verb, is interpreted as a function. The n-place function assigned to a verb with n-arguments has the Boolean values {0,1} for its range, while the one-place function assigned to an adjective has subsets of the domain for its range. Indeed, the set yielded from the one-place function assigned to an adjective is a subset of the set assigned to the noun it modifies. So, for example, the noun phrase the rich men denotes, modulo the deictic constraint imposed by the indefinite article, a subset of the set denoted by men such that they are rich. What, exactly, this function is is stated below.

(41) Principle of Interpretation of Adjectives

Let A be an adjective. Let D be a domain of individuals whose power set is the domain of interpretation. Let A_D be the extension of the adjective in the domain. $A^p(Y)$ is the one-place function, $A_D \cap Y$, where Y takes sets as values and A^D yields sets as values.

The principle has several attractive features. First, it accomodates the interpretation of iterated adjectives, be they co-ordinated or embedded. Co-ordinated adjectives are interpreted as the intersection of the functions assigned to each of the adjectives co-ordinated; adjectives within adjective phrases are interpreted as the composition of the functions assigned to each adjective in the embedding, the most embedded adjective corresponding to the left-most function in the composition of functions. Let me illustrate this point with a pair of examples.

(42)

1. these [_{AP} rich] [_{AP} handsome] lawyers
2. the [_{AP} [_{AP} happy] young] adults

Second, this principle also accomodates the fact that adjectival modification of a noun may eliminate, or interfere with, the denotation of the whole noun phrase. In (42.1), for example, the domain may have lawyers, but no rich and handsome ones, so that while lawyers will denote a non-singleton subset of the domain, the whole phrase will denote the null set. And, this principle interacts with the principles pertaining to the syntax and semantics of the feature +PL to interfere, in the way in which the facts require, with the denotation of the entire noun phrase. To see this, recall that the syntactic features of a

head noun are assigned to its phrasal node (i.e., maximal projection), that is, its noun phrase. (See (24.2) of 2.1.3 above.) Recall also that the interpretation of the features of +PL puts constraints on the cardinality of the set denoted by the associated node. (See (3) of 4.1.1 above.) This implies, in the case of (42.2), that the denotation of the entire phrase must have such a denotation. Yet the function assigned to the largest adjective phrase may, in a suitably chosen domain, return to a singleton subset of the domain. In such a situation, the noun phrase is clearly to be judged anomalous, and the principles adduced here reflect that judgement.

Finally, notice that (41) can be easily adapted to accomodate collective and distributive readings by modifying the functions in (41) to compute over plurality covers. Assuming that words such as swarming or rolling are not participles but adjectives, one might think the following examples warrant such a modification.<4>

(43)

1. *the swarming bee
2. the swarming bees
3. *the rolling hill
4. the rolling hills

It is clear that a bee does not swarm but that bees swarm, and that a hill does not roll (in the relevant sense) but that hills roll. This means that such expressions as rolling and swarming must have readings where they are true of plurality covers of the denotation of the nouns they modify which do not contain singletons from the domain. It is also clear that they may have to yield such plurality covers as values.

(45)

1. *the swarming bees each fly.
2. the swarming bees all fly.

Another enrichment of the simple noun phrase susceptible of interpretation on the basis of a straightforward extension of principles found in the earlier chapters is the simple noun phrase augmented by a prenominal cardinal adjective. Examples of such noun phrases are: two men, three women, seven archaeologists. The interpretation of the cardinal adjective is a cardinal number; and the interpretation of the augmented simple noun phrase in which the cardinal adjective occurs is the set denoted by the simple noun phrase itself such that its cardinality is the number denoted by the cardinal adjective. That is,

(46) Principle of Interpretation for Simple Noun Phrases

Let D be a domain of individuals whose power

set is the domain of interpretation. Let
 $[_{NP} [_{AP} A] [_{\bar{N}} N]]$ be a noun phrase. Let $A^D = n$.
 Then $NP^D = \bar{N}^D$ and $|\bar{N}^D| = n$.

Thus, two men denotes any set of two men, three women denotes any set of three women, etc.

With this principle and those of the last chapter, sentences like the following are easily interpreted.<5>

(47) Two men visited two women.

Now let two men denote the set consisting in Rick and Randy and let two women denote the set consisting in Diane and Lillian. There are eight readings (see Figure 2 in 4.3 above), one of which is that Rick visited Diane and Randy visited Lillian (see (4) in Figure 2 of 4.3 above). This reading cannot be captured if two is a quantifier and QR applies to all quantifiers, for one occurrence of two must then have wider scope than the other; but no one person visits or is visited by any two others. On the view here, cardinal adjectives are not determiners (see 2.1.1 above), hence not quantifiers, nor are they lexically derived from quantifiers, so they are not subject to QR. Moreover, on the view here, all readings are captured.<6>

Before adverting to simple noun phrases with prepositional phrases, I shall address a question raised, but not answered, in the third chapter (namely, in 3.1.1 above): the question of the

principle of interpretation for demonstratives. I suggested there that demonstratives can be assigned semantic features (e.g., +DEICTIC or -DEICTIC, and +PROXIMATE or -PROXIMATE) and that the interpretation of demonstratives is a Boolean function of functions interpreting these features. Left unresolved was the kind of function to be assigned to these semantic features. These functions have subsets of the domain of interpretation as their domain and subsets of the objects of the situation of utterance for their range. This can be formulated more precisely as follows:

(48) Principle of Interpretation for Demonstratives

Let D be a domain of individuals. And let the power set of D be the domain of interpretation. Let S be the objects in the situation of utterance. Let A be a demonstrative and a_1, \dots, a_n its associated features. a_{1D}, \dots, a_{nD} is the extension of these features in the situation of utterance. Let A^D be a Boolean function in a_{1D}, \dots, a_{nD} . Then $A^D(Y) = A_D \cap Y$.

So while demonstratives and adjectives fall into distinct syntactic categories, they are subject to the same kind of interpreting function, differentiated only by a difference in ranges and domains of the functions.

5.2.2 Simple Noun Phrases with Prepositional Phrases Interpreted

The interpretation of a noun phrase which consists in a simple noun phrase augmented by a prepositional phrase, which itself consists in the preposition of and a simple noun phrase, is a more involved task than the one just undertaken, for the results of earlier chapters have not prepared the way to the same degree. First, there is no discussion of prepositions and prepositional phrases in the earlier chapters. It turns out that there are different configurations into which a noun which is the head of a noun phrase and a prepositional phrase can enter. Second, no treatment of the argument structure of nouns was undertaken in earlier chapters. And, it turns out that there are count nouns, which are to be interpreted as sets. The sets which they are assigned are determined by their argument structure; and the determination is effected through the syntactic configuration in which the noun with the argument structure finds itself. Below, I shall examine first the syntax of prepositional phrases within noun phrases, isolating therein one configuration which will prove pertinent to the discussion in the next chapter. Then, I shall advert to the structure of the lexical entry of a noun, concentrating on the argument structure of a noun, and again isolating a class of nouns in terms of their argument structure which will later prove germane.

Since Jackendoff (1977: Chapter 4, Sect. 5), it has been

widely assumed that there are two positions in the phrase marker of a noun phrase for a prepositional phrase: one position is sister to the N node of the noun phrase, the other is sister to the \bar{N} node of the noun phrase. These positions are illustrated below as PP_1 and PP_2 , and will be referred to as N complement prepositional phrases and \bar{N} complement prepositional phrases, respectively.

(49)

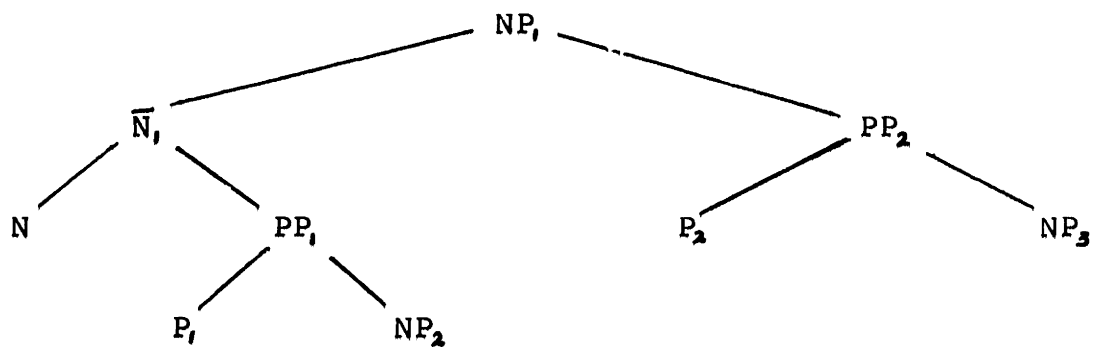

This distinction in syntactic configuration provides a basis for accounting for the following facts. First, while some prepositional phrases may not iterate, others may.

(50)

1. a student [*pp* with a scar] [*pp* from Canada]
2. a cottage [*pp* by a lake] [*pp* in a woods]

3. *the kind [pp of France] [pp of England]
4. *the dislike [pp of bathing] [pp of children]

Second, in some iterations of prepositional phrases, the prepositional phrases do not permute.

(51)

1. every relative [pp of my mother] [pp from Ireland]
2. ?*every relative [pp from Ireland] [pp of my mother]
3. the queen [pp of Bhutan] [pp from Manhattan]
4. *the queen [pp from Manhattan] [pp of Bhutan]

Finally, the antecedents of one, the pronoun, sometimes includes the prepositional phrase in the noun phrase, and sometimes does not.

(52)

1. Dave met the queen from Kensington, and Peter met the one from Manhattan.
2. *Dave met the queen of England, and Peter met the one of Bhutan.

Now these facts are implied on the basis of the syntax of (49) with the additional assumptions that the antecedent of one is an \bar{N} node and that only \bar{N} complement prepositional phrases iterate. Adopting, then, this analysis of prepositional phrases, I can now state more precisely the syntactic configuration, the semantic interpretation of which is the concern of the remainder of this

chapter: simple noun phrases augmented by N complement
prepositional phrases whose own noun phrases are simple ones.

If N complement prepositional phrases provide the relevant noun phrases, what kind of count noun provides the relevant kind of head noun? In the previous chapter, the principle for the interpretation of nouns took account of nouns with no argument structure in their lexical entries. And surely there are nouns with no argument structure: man, woman, elephant, bagpipe, chopstick, etc. But it also seems that there are nouns with argument structure: seduction, dislike, refusal, etc. It is through the ascription of argument structure to such nouns that some expect to capture the undeniable parallel between sentences and noun phrases.

(53)

1. Cleopatra seduced Julius Ceasar.
2. Cleopatra's seduction of Julius Ceasar

(54)

1. Every boy dislikes bathing.
2. Every boy's dislike of bathing

(55)

1. Nabil refused an offer.
2. Nabil's refusal of an offer

But the nouns with argument structure are not just those which are derived from verbs. Nouns such as relative, sister, friend, capital, king, etc., also have argument structure too; and it is these nouns, which I shall call "relational nouns", which are of interest here.

Having identified N complement prepositional phrases and the class of relational nouns, I can state more precisely the aim of the balance of this section of the chapter: to provide the principles of interpretation whereby the interpretation of \bar{N} can be given in terms of the interpretation of N and its complementary prepositional phrase, where N is a relational noun. But these principles are already in place, except for a slight enrichment of the principle for the interpretation of count nouns presented in the fourth chapter. So let me state how the principle is to be enriched, then I shall proceed to show how the principles stated so far provide an interpretation for the kind of N just identified.

The principle for the interpretation of count nouns given in the third chapter is simple: a count noun is assigned a subset

of the domain of interpretation, in particular, its extension in the domain. (See (5) in 3.2.1 above.) There seems to be no grounds to abrogate such a principle for the interpretation of relational count nouns. Consider these examples:

(56)

1. The relatives are visiting.
2. My friends like one another.

Yet, the set assigned to a relational count noun evidently depends on the set assigned to the noun phrase in its complementary prepositional phrase, for the denotation of the subject noun phrase in each of the next examples is different from that in the others.

(57)

1. The relatives of my father are visiting.
2. The relatives of my mother are visiting.
3. The relatives of my wife are visiting.

How, then, are relational count nouns to be interpreted? The answer, I believe, lies in the very description of the problem: a relational count noun is assigned a subset of the domain or a set provided by a function also assigned to the count noun, which has for its domain subsets of the domain of interpretation and has for its range subsets of the set assigned to the count noun

itself. The precise formulation is the following:

(58) Principle of Interpretation for Count Nouns:

Let C be a count noun. Let D be the domain of interpretation. Let C_D be the extension of C in D.

- (1) If C has no argument place, then $C^D = C_D$.
- (2) If C has an argument place, then C^D is a function of subsets of D into subsets of C_D .

How these principles work requires some explanation. Bear in mind that the interest here is only in count nouns. Above, I pointed out that some count nouns have arguments and others do not. Moreover, I adduced the view that the \bar{N} node has only two configurations:

(59)

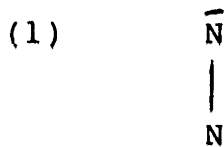

(2)

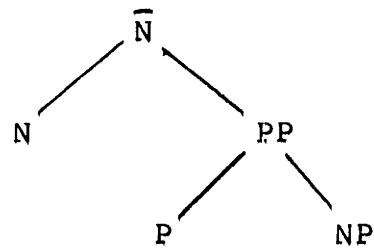

So, there are only four cases to consider. Suppose a count noun is inserted under N which has no argument. Then regardless of whether it is in one or the other of the configurations in (59), it does not have an argument to assign, so only clause (2) will

apply. Now suppose a count noun with an argument is inserted under an N node. Then the question arises: to what is the argument assigned? An answer to this question was proposed in a previous chapter: a distinguished argument is assigned to an external argument position and an undistinguished argument is assigned to an internal argument position. Nouns, I observed above, have only undistinguished arguments; and a relational count noun has only one undistinguished argument. So, in the first configuration in (59), there is no external argument position with respect to N within \bar{N} . Indeed, since \bar{N} immediately dominates only one other node, then the interpretation of the node \bar{N} is the same as that of N, according to the principle that non-branching nodes are essentially semantically vacuous. (See (2) in 4.1.1 above.) Now in the second configuration of (59), the NP node is the internal argument position of the node N, hence the count noun in question assigns its undistinguished argument to the NP node, so clause (1) of (58) will apply with the result that \bar{N}^D is the subset of C_D assigned by f_c at the value NP^D , that is to say,

$$(60) \quad [\bar{N} [N C] [pp [p \text{ of}] [NP A]]]^D = f_c(NP^D).$$

To insure that the application of these principles is clear, let me rehearse an example. Consider the noun phrase which is the subject of (57.1). It has the structure of (59.2). The noun

phrase my father is interpreted as a singleton in the domain of interpretation. The noun relatives, which has the syntactic feature +PL, is assigned a set in the same domain as well as a function from subsets of the domain into subsets of the non-singleton assigned to relatives. The feature +PL is assigned to the node NP by the rule that features of heads are assigned to their phrasal nodes. (See (24.2) in 2.1.3 above.) Now relatives has an argument, and by the rules of argument assignment, it is assigned to the NP node dominating my father. (See (24) of 3.3 above.) Hence, the first N node contained in the subject noun phrase will be assigned the set yielded by the function assigned to relatives at the value assigned to the NP node dominating my father. Presumably this set is all those related to my father. Were relatives replaced by sisters and the person denoted by my father an only child, then the noun phrase would fail to denote. And if the person denoted by my father had just one sister, then the interpretation of the NP node dominating the prepositional phrase would fail to meet the condition imposed by the feature of +PL, since the set assigned to the NP node would be a singleton but the feature requires that the set have a cardinality greater than one.

5.3 Conclusion

It should now be clear that one has the syntactic and semantic wherewithal to provide interpretations for fairly complex sentences, including ones like the following:

(61)

1. The sisters of my father and the brothers of my mother are rowing.
2. The boys and the girls respect one another.
3. Every governor of some state and every district attorney of some municipality met the president.
4. Every relative of some villager and every relative of some townsman hate each other.

It is precisely sentences like the last one which Hintikka claims to require branching quantification for their proper semantic representation. In the next chapter, I shall examine Hintikka's claims and evaluate his treatment of sentences like (61.4) in light of the results I have set out so far in this thesis.

FOOTNOTES - CHAPTER FIVE

1. This point is acknowledged by Postal (1976: 153, n. 11).
2. The claim is that this is not a constituent; it is not that this sequence cannot occur. For the time being, think of these judgments as made with respect to frame sentences like (5.2).
3. This point is acknowledged by Postal (1976: 153, n. 10).
4. Expressions of this kind were pointed out to me by Lenhart Schubert.
5. This problem and example was brought to my attention in lectures by Jim Higginbotham during his course in the Spring term of 1983.
6. In my judgment, phrases such as two men have specific and non-specific readings. If this is so, these facts would fall within the purview of the treatment of the indefinite article by Fodor and Sag (1982) to the effect that it is both a quantifier and a demonstrative, under the supplementary hypothesis that the plural form of the indefinite article is phonetically null, Greg Carlson (1977) notwithstanding (see 3.1.1 above). In this event, such phrase as two men would be subject to QR when they contain the plural form of the quantifier a. But this would in no way interfere with the readings above.

CHAPTER SIX

HINTIKKA AND BRANCHING QUANTIFIERS

6.0 Introduction

In a series of articles starting in 1973^{<1>}, Hintikka has argued for the view that there are sentences of English, quantificational aspects of which are properly represented by branching quantifiers. Among his examples are these:

(1)

1. Some book by every author is referred to in some essay by every critic.
2. Some relative of every villager and some relative of every townsman hate each other.

In this chapter, I shall scrutinize the view both in terms of the evidence he brings to bear and in terms of the syntactic and semantic analysis presented in the previous chapters. This scrutiny will reveal that what Hintikka alleges to be the truth conditions of these sentences is wrong and that they can receive a better, and different, analysis through the view adopted or developed above. As Hintikka's own proposal is based on the notion of branching quantifiers, let me first summarize the facts pertaining to this theory of logic.

6.1 Theory of Branching Quantification

The idea of branching quantification, or finite partially-ordered quantification, was first propounded by Leon Henkin (1961). This theory is a generalization of the syntax of quantifiers of first order predicate logic which are in prenex normal form. (A formula of first order logic is in prenex normal form, if every propositional connective is within the scope of every quantifier.) Thus, for example, " $\exists y$ " is within the scope of " $\forall x$ " in the formula below.

$$(2) \quad \forall x (Fx \text{ ----} \rightarrow \exists y Gy)$$

So it is not prenex normal form. On the other hand, the next formula is.

$$(3) \quad \forall x \exists y (Fx \text{ --} \rightarrow Gy)$$

Now it is a (meta-)theorem of first order logic that each formula has an equivalent in prenex normal form. So, a formula which is not in prenex normal form, like the following,

$$(4) \quad \exists x \forall y (Fxy \text{ ----} \rightarrow \forall y \exists x Gxy),$$

has a formula which is logically equivalent to it and in prenex

normal form^{<2>}, namely,

(5) $\exists x \forall y \forall v \exists w (Fxy \rightarrow Gwv)$.

A formula in prenex normal form can be thought to be made up of two parts, a prefix which consists in all the quantifiers, and a matrix which consists in all the formula but the prefix. So, in (5), " $\exists x \forall y \forall v \exists w$ " is the prefix and " $(Fxy \rightarrow Gwv)$ " is the matrix. Now, in first order logic, the elements of a formula are totally ordered. That is to say, for any two elements, if neither precedes the other then they are the same element. Formulae in prenex normal form, of course, are totally ordered. In particular, the quantifiers of the prefix are totally ordered: that is, for any two quantifiers, if neither precedes the other, then they are identical. This implies that the relation of scope between quantifiers (in the prefix of a formula in prenex normal form) is defined for any pair of quantifiers.

In the theory of finite partially-ordered quantification (i.e., the theory of branching quantification), the prefixes are permitted to be partially ordered (i.e., "branch"). That is, it is no longer the case that either two quantifiers are so arranged that one precedes the other or they are identical. So, they can

be unordered with respect to one another. This, in turn, implies that the relation of scope is not defined for every pair of quantifiers. For example, the quantifiers " $\forall x$ " and " $\exists y$ " are unordered with respect to one another in the next formula, and so the relation of scope is not defined between them.

(6)

$$\begin{array}{l} \forall x \\ \exists y \end{array} \rangle Fxy$$

In the next formula, " $\forall x$ " and " $\exists y$ " are ordered with respect to each other, as are " $\forall v$ " and " $\exists w$ "; but " $\forall x$ " and " $\forall v$ " are not ordered with respect to each other, as are not " $\exists w$ " and " $\exists y$ ".

(7)

$$\begin{array}{l} \forall x \exists y \\ \forall v \exists w \end{array} \rangle Fxyvw$$

Now, some observations about the theory of branching quantification are in order. First, since a total ordering is a special case of a partial ordering, formulae of first order predicate logic in prenex normal form are a special case of the formulae of the theory of branching quantification. It is convenient to designate any formula of the theory of branching

quantification which is not also a formula of first order predicate logic as "properly branching", and any which is a formula of both as "improperly branching". On this convention, (6) and (7) are properly branching formulae, whereas (5) is improperly branching. Second, Walkoe (1970: 542) has shown that every properly branching formula has an equivalent, both among formulae of the kind indicated by (8), and among the formulae of the kind indicated by (9).

(8)

$$\begin{array}{l}
 \forall x_1 \dots \forall x_i \exists y_1 \dots \exists y_j \\
 \forall v_1 \dots \forall v_k \exists w_1 \dots \exists w_l
 \end{array}
 \begin{array}{l}
 \diagup \\
 \diagdown
 \end{array}
 Fx_1 \dots x_i y_1 \dots y_j v_1 \dots v_k w_1 \dots w_l$$

(9)

$$\begin{array}{l}
 \forall x_i \forall y_i \exists z_i \\
 \cdot \quad \cdot \quad \cdot \\
 \cdot \quad \cdot \quad \cdot \\
 \forall x_i \forall y_i \exists z_i
 \end{array}
 \begin{array}{l}
 \diagup \\
 \diagdown
 \end{array}
 Fx_1 \dots x_i y_1 \dots y_i z_1 \dots z_i$$

Third, some properly branching formulae have first order equivalents, as shown in the table below (taken from Barwise 1979).

Properly Branching Formulae

Equivalent Non-Branching Formulae

(10)

$$\begin{matrix} \forall x \\ \forall y \end{matrix} \rangle Fxy$$

$$\forall x \forall y Fxy$$

(11)

$$\begin{matrix} \exists x \\ \exists y \end{matrix} \rangle Fxy$$

$$\exists y \exists x Fxy$$

(12)

$$\begin{matrix} \forall x \\ \exists y \end{matrix} \rangle Fxy$$

$$\exists y \forall x Fxy$$

(13)

$$\begin{matrix} \forall x \exists y \\ \forall w \exists v \end{matrix} \rangle Fxyvw$$

$$\exists f \exists g \forall x \forall v F x f(x) v g(v)$$

Table 1

But some properly branching formulae have no first order equivalent. The simplest such formula is (7), repeated as (13) in Table 1. However, as shown by Enderton (1970: 394), every properly branching formula does have a logically equivalent formula in a restricted class of formulae of second order predicate logic. The logical equivalent of (13) is this formula of second order logic.

$$(14) \quad \exists f \exists g \forall x \forall v \quad F x f(x) v g(v)$$

What is, intuitively, the relation between (7) and (14), that is, the pair of formulae in (13)? The properly branching formula of (13) tells one that the value of "y" is permitted to depend only on the value of "x" (in any event, it does not depend on the value of "v" or of "w") and that the value of "w" is permitted to depend only on the value of "v" (and again, in any event, it does not depend on the value of "x" or of "y"). And this was also asserted in the second order formula of (14); for it says that the value of "y", if it is a function of anything, is a function only of the value of "x" and that the value of "w", if it is a function of anything, is a function only of the value of "v".

In contrast, consider the simple formula of first order

logic whose parts are only " $\forall x \exists y$ ", " $\forall v \exists w$ ", and " $Fxyvw$ ", taken from (14).<3>

(15) $\forall x \exists y \forall v \exists w Fxyvw$

Returning to the intuitive conception of quantifier order mentioned above, one can see that in (15), as in (7), the value of "y" may depend only on the value of "x". But, in (15), the value of "w" may depend on the values of both "x" and of "v"; whereas, in (7), it may depend only on the values of "x". In other words, both in (7) and in (15), the value of "y" may be a function only of the value of "x"; but in (15), the value of "w" may be a function both of the value of "x" and the value of "v", while in (7) it may be only a function of the value of "v". Using the same function notation of second order logic which was used above, one can represent (15) as follows:

(16) $\exists f \exists g \forall x \forall v F x f(x) v g(x,v)$

This formula, which is logically equivalent to (15), differs from the one in (14), which is logically equivalent to (7), inasmuch as the fourth place of the predicate is a function of one variable, namely $g(v)$, in the case of (14), but is a function of two variables, namely $g(x,v)$, in the case of (15). Since

functions of two variables include, as degenerate cases, functions of one variable, it follows that the set of models satisfying (14) is a subset of those satisfying (16). Therefore, (14) implies (16), and so (7) implies (15). The converse implication, as will be shown, does not hold.

It is convenient to mention in passing that the formula

$$(17) \quad \forall x \forall v \exists y \exists w Fxyvw$$

is implied by (16). Following the same reasoning as above, one observes that (17) is logically equivalent to the second order formula

$$(18) \quad \exists f \exists g \forall x \forall v F x f(x,v) v g(x,v).$$

(16) is evidently a special case of (7), and hence has only a subset of the models satisfying (18) satisfying it.

6.2 Branching Quantifiers and Simple Sentences

Having said this much about the theory of branching quantification, let me turn to the theory of quantification in natural language. In Chapter One, I sketched a view of quantifiers in natural language which not only holds that relations of scope among quantifiers obtain but also shows how

these relations are defined on the basis of the syntactic structure of sentences. Hintikka's view is unclear on both of these points. While it is implicit in his discussion that quantifiers may enter into relations of scope, he is silent on the issue of how these relations are to be assigned. This silence is a persistent shortcoming of Hintikka's treatment of the sentences he scrutinizes; and this shortcoming is easily overlooked when one is embroiled in the details of the analysis of the more complex sentences he presents. To highlight its importance, let me turn first to a treatment of the relations of scope found in sentences syntactically simpler than those discussed by Hintikka. Hintikka does not explicitly propose to use branching quantifiers to represent their semantics; but to see why one ought not to use branching quantifiers in their treatment will bring into salience a point which carries over to the treatment of the syntactically more complex sentences actually discussed by Hintikka.

To begin with, reconsider these sentences of two quantifiers and one binary relation.

(19)

1. Every man admires every woman.
2. Some man admires some woman.

3. Every man admires some woman.
4. Some man admires every woman.

Now, how might branching quantifiers be used here? One might propose that the quantifiers of natural language (within a simple sentence) bear no relations of scope. This would be represented by having all the quantifiers in the sentence represented by a branching formula with as many branches as there are quantifiers in the sentence. This proposal does not run afoul of the facts, as evidenced by (19.1) and (19.2), for the two improperly branching representations on the one hand and the one properly branching representation on the other are equivalent for each sentence. (See Table 1.) But all other things being equal, the representation by properly branching quantification would be gratuitous. Now a representation by properly branching quantification can also capture the interpretation of (19.3) in which there is only one woman whom every man admires; but it cannot capture its other interpretation. (See 1.2.3 above.) Moreover, a properly branching representation of the next sentence implies that it has only an absurd reading.

(20) An oak grew from every acorn.

But, as was shown before, it has a perfectly sensible reading as well -- a reading properly branching quantifiers cannot

represent.

Of course, a theory of quantification in natural language which avails itself of properly branching quantifiers need not prohibit representations by improperly branching ones. But if such a theory permits both kinds of representation, then the redundancy of the branching quantifiers calls them into question. And more importantly, if properly branching quantifiers are sometimes assigned and sometimes not assigned, then the natural question is: what determines the assignment? And this is the question which Hintikka never addresses.

It is not easy to ascertain whether or not Hintikka is aware of this problem. His purpose is to find sentences in natural language which can be represented by branching quantifiers. At the same time, however, he seems unaware that his assignment of branching quantifiers to sentences has no basis in the structure of sentences. This is suggested in one brief passage (Hintikka 1973).⁴ Hintikka considers the sentence

(21) John has shown all his paintings to some of his friends.

And he points out that it has two construals, which he says can be represented as follows:

(22)

$\forall y ((y \text{ is a painting of John's}) \rightarrow \exists x (x \text{ is a friend of John's and John has shown } y \text{ to } x)).$

(23)

$\exists x (x \text{ is a friend of John's and } \forall y (y \text{ is a painting of John's} \rightarrow \text{John has shown } y \text{ to } x)).$

Hintikka claims the latter construal to be the more natural by far. He goes on to assert that (21)'s second construal is better represented by properly branching quantification, as follows:

(24)

$\exists x \begin{array}{l} \diagup \\ \diagdown \end{array} \left(\begin{array}{l} (x \text{ is a friend of John's and } (y \text{ is a painting of John's} \\ \rightarrow \text{John has shown } x \text{ to } y)) \end{array} \right)$

But this is just a more complex instance of the same issue raised with respect to (19.3). As with (21) so with (20), there is one interpretation which properly branching quantifiers cannot represent, namely, the one where the universal quantifier has wider scope than the existential one -- (22) in the case just mentioned.<5> Thus, improperly branching quantifiers are

required as well as properly branching ones. Hence, the question arises: when are properly branching ones required and when are improperly branching ones required? Hintikka does not provide a way to choose; instead, he simply asserts that "the most natural explanation of the actually preferred reading (23) of (21) here is to assume that the two quantifiers in (21) are independent".⁶ Here, what Hintikka means by "independent" is that the speaker, or hearer, does not have enough information to relate the quantifiers to each other, and hence, for him, the quantifiers are informationally independent. But this is no explanation at all: what information is available to a speaker, or hearer, is irrelevant to the question of the ambiguity here. Ask anyone whether sentence (19.3), or other sentences like it, is ambiguous, and he will make the judgement that it is, despite the fact that the sentence is completely out of context for him, and so despite the fact he has no information about the real world pertinent to the construal of the sentence in question.

This view of Hintikka's contrasts with the view of quantification in natural language presented here. The latter makes very specific predications about the relations of scope for quantifiers in sentences -- and, in particular, sentences in (19) -- on the basis of their syntactic structure. The former view does not.

6.3.1 A Case for Representation by Branching Quantification

Having anticipated one pervasive shortcoming of Hintikka's treatment of quantification in natural language, let me turn now to one of his candidates for representation by branching quantifiers:

- (25) Some book by every author is referred to in some essay by every critic.

According to Hintikka (1973), <6> this sentence is to be represented as follows:

(26)

$$\begin{array}{l} (\forall x: \text{author } x)(\exists y: \text{book } y) \\ (\forall v: \text{critic } v)(\exists w: \text{essay } w) \end{array} \left\{ \begin{array}{l} (y \text{ is by } x \wedge w \text{ is by } v \wedge \\ y \text{ is referred to in } w). \end{array} \right.$$

In contrast, QR assigns three logically distinct interpretations to (25): namely,

(27)

$$\begin{array}{l} (\forall x: \text{author } x)(\exists y: \text{book } y)(\forall v: \text{critic } v)(\exists w: \text{essay } w) \\ (y \text{ is by } x \wedge w \text{ is by } v \wedge y \text{ is referred to in } w). \end{array}$$

(28)

$(\forall v: \text{critic } v)(\exists w: \text{essay } w)(\forall x: \text{author } x)(\exists y: \text{book } y)$
(y is by x \wedge w is by v \wedge y is referred to in w).

(29)

$(\forall x: \text{author } x)(\forall v: \text{critic } v)(\exists y: \text{book } y)(\exists w: \text{essay } w)$
(y is by x \wedge w is by v \wedge y is referred to in w).

That is, derived from the phrase marker of (25) at SS, namely,

(30)

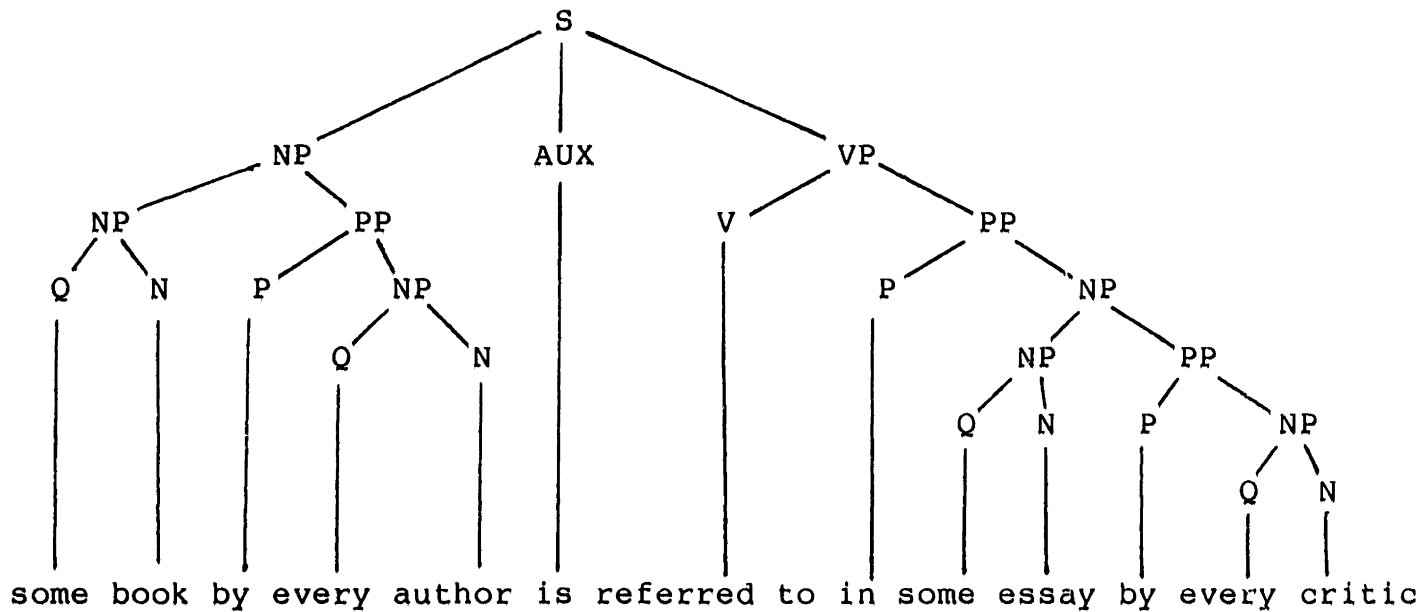

are from phrase markers equivalent to (29), one equivalent to (28) and one equivalent to (27).

Now what are the logical connections among the representations (26), (27), (28), and (29)? It is that (26) implies (27) and (28), neither (27) nor (28) implies the other, but both imply (29).

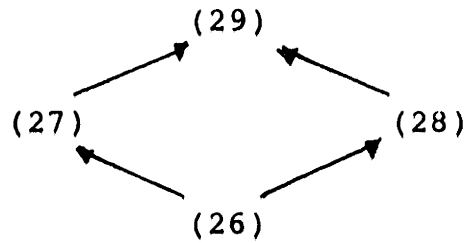

Figure 1

The easiest way to see what these implications are is to observe the kind of schemata in the formal language of the theory of finite, partially ordered quantification each of (26) through (29) instantiate:

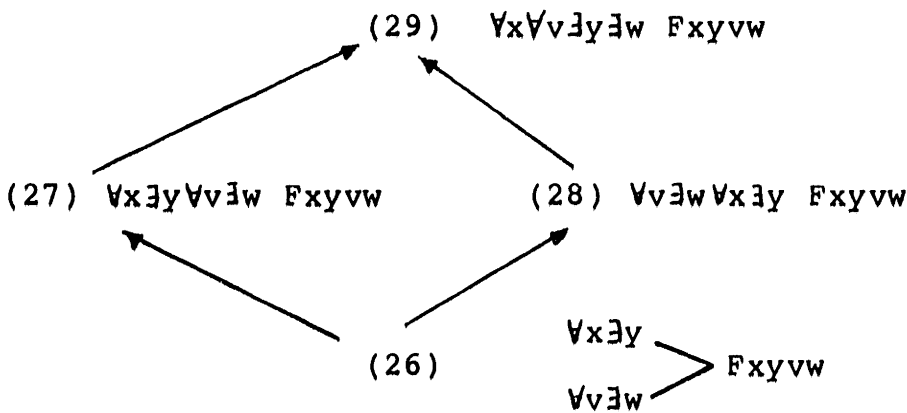

Figure 2

Next, recall what was shown at the end of section 6.1, namely, that each of these schemata have a second order equivalent.

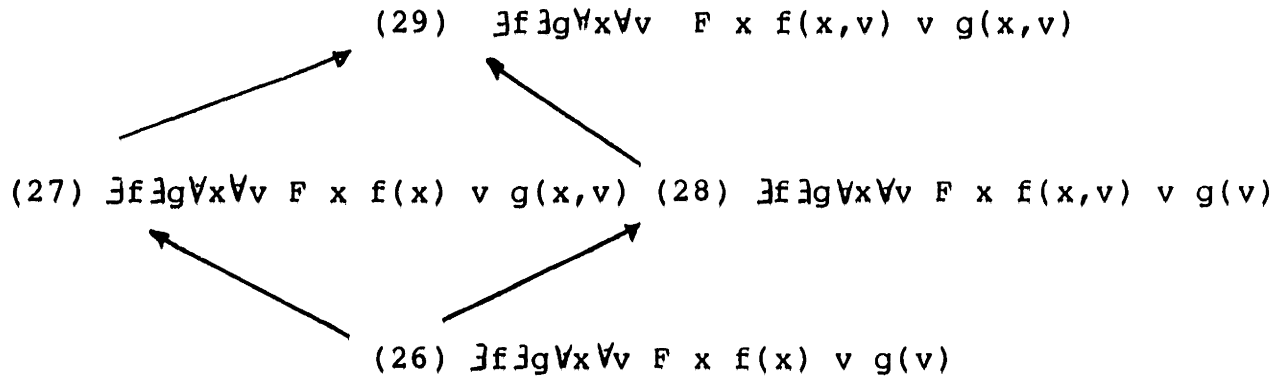

Figure 3

As was pointed out in the same place, every one-place function is a special case of a two-place function. One can see, in Figure 3 then, that (26) is a special case of both (27) and (28) and that they are both special cases of (29). So (27) and (28) are satisfied in all the models that (26) is satisfied in; and (29) is satisfied in all the models that either (27) or (28) are satisfied in.

Moreover, (26) through (29) are logically distinct. To see this, one merely needs to stipulate models so that for any pair of these formulae, one is satisfied in one of the models and the other is not. Since the relations expressed in the formulae are

all binary, one can turn to the diagrams of directed graphs for the representation of the models to be stipulated below. In these diagrams, nodes, which are labelled, represent individuals in the domain of the model, and directed arcs between individuals represent relations between individuals. "A" labels an individual author; "B", an individual book; "C", an individual critic; and "E", an individual essay.

The first model consists in two authors, two critics, two books and two essays. There are also two one-place functions: one maps authors into books, say the best selling book by _____; and the other maps critics into essays, say the longest essay by _____. Finally, there is a binary relation, namely referred to in, which books bear to essays. Using labelled circles to represent individuals and directed arrows to represent relations and functions, one can depict the model in the following diagram.

MODEL 1:

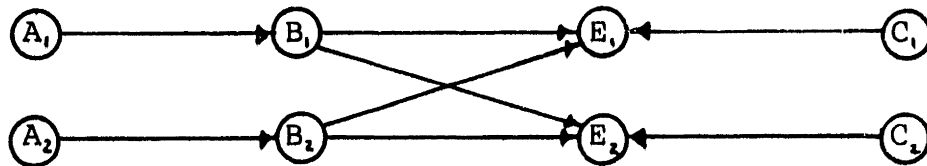

Figure 4

It is clear from how the model is set up that (26) is satisfied in it: a book relevant to an essay depends on the author alone, and similarly an essay relevant to a book depends on the critic alone. Naturally, (27), (28), and (29) are satisfied in it as well.

In the second model, there are two authors, two critics, two books and four essays. In this model, there are two functions. One is a one-place function, mapping authors onto books (the bestselling book by _____). The other is a two-place function, mapping a pair, consisting of a critic and an author, onto an essay (an obituary essay on _____ by _____). And finally, there is a binary relation, borne by books to obituary essays, the relation of being referred to in. Again, a diagram will represent the particulars.

MODEL 2

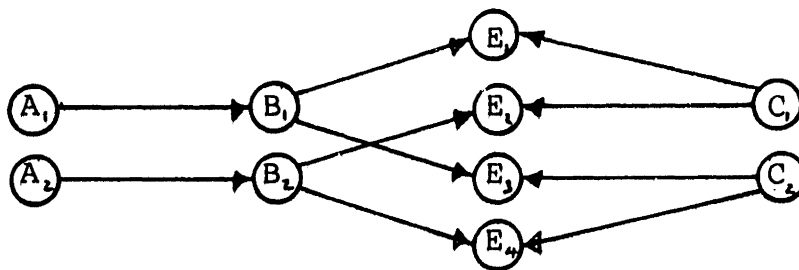

Figure 5

Now, (26) is not satisfied in the model depicted above precisely

because the appropriate essay for the relation to obtain with respect to a book depends on both the choice of critic and the choice of author. But this is exactly what is required by (27). So (27) is satisfied in this model. Again, since (27) implies (29), (29) is also satisfied in this model. However, (28) is not satisfied in it. Whereas the choice of both is vacuously a function of the choice of author and critic, since it is only a function of the choice of author; the choice of essay, in contrast, may depend both on the choice of author and the choice of critic. Indeed, this is shown in the next model.

Again, there are two authors and two critics; but instead of two books and four essays, as in the last model, there are four books and two essays. There is, once more, the binary relation of books to essays, the relation of being referred to in, and there are two functions: the one-place function of the first model which maps critics onto their essays (the longest essay by _____), and a two-place function which maps authors onto their books (authoring).

MODEL 3

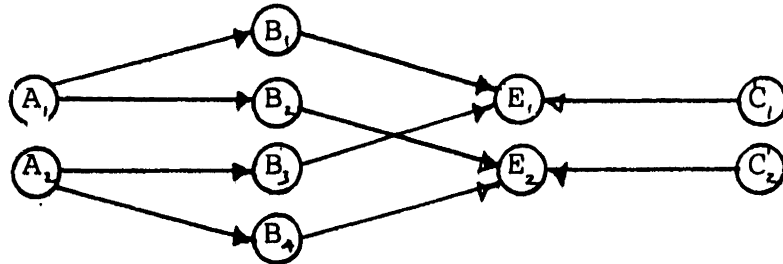

Figure 6

This model is the mirror image of Model 2, and analogous reasoning to that in the previous paragraph applies. (26) is not satisfied since the choice of the appropriate book for the relation to obtain with respect to the essay depends on both the choice of critic and the choice of author. But (26) cannot take account of both these choices. Neither can (27) take account of both these choices, so it too fails in the model. But (28) can accomodate both choices, as is reflected by its logical equivalent in second order logic in the assertion of the existence of a function of two variables mapping pairs of authors and critics into essays. Of course since (28) is satisfied in Model 3, then (29) is too.

It should be evident in the last model, given below, satisfies (29) but does not satisfy either (27) or (28) (and so, does not satisfy (26)).

MODEL 4

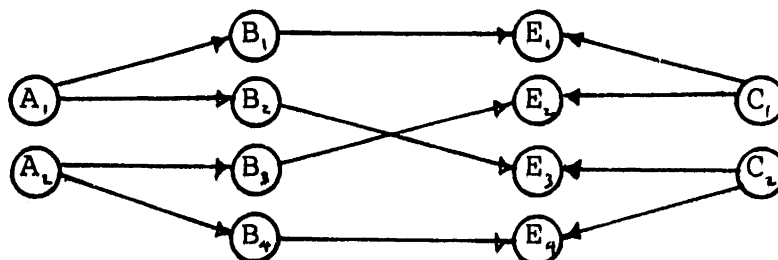

Figure 7

Now that the interpretations ascribed to Hintikka's sentence (25) by the two competing proposals are clear and differentiated, the question of which proposal is correct can be addressed. One obstacle, however, stands in the way. The data are difficult to pin down: judgments are frequently uncertain or unclear. There are two reasons for this. First, the sentence itself is rather complex. Second, the interpretation ascribed to (25) by Hintikka implies the interpretations ascribed to (25) by QR. These two reasons should not be taken as grounds to belittle the investigation into the issue as trivial or esoteric. It is a fact of scientific investigation that as a theory becomes more comprehensive, then the data needed to adjudicate between competing hypotheses formulated within the theory become more arcane and difficult to find. What this translates into in the physical sciences is the growing sophistication of

instrumentation (among other things). So, then, how is one to decide between the two proposals?

Fauconnier (1975) provides a way of eliciting judgments more clearly and in a way more telling of the basis for the judgment. Instead of asking for a judgment of a single sentence, such as (25), Fauconnier (1975: 559-560), in effect, asks for judgments concerning the consistency of sets of sentences. For example, are these sentences consistent?

(31)

1. A man loves only one woman at a time.
2. A dancer belongs to only one ballet troupe at a time.
3. Some player of every NFL team loves some dancer of every ballet troupe.

If Hintikka's reading is the only one, then this triplet can be satisfied only in models with one NFL team which has only one player and one ballet troupe which has only one dancer. But this is not the judgment of speakers. Similar considerations apply to another triplet.

(32)

1. A spy lives in only one house at a time.
2. A house is only in one city.
3. Some spy of every firm lives in some house of every major city.

What Fauconnier has shown, then, is that Hintikka's representation of (24), and sentences like it, imposes too narrow a range of interpretation. In contrast, QR provides a representation which accomodates the range of interpretation required for the judgments Fauconnier gets at with his examples, for these examples fall within the range of interpretation imposed by representations of the same form as (29) (the logically weakest of the representations generated by QR), and its analogues.

Finally, Fauconnier (1975: 560-561) suggests that one consider sentences like (24) framed in terms such that the background assumptions shared by speakers will determine the truth or falsity of the sentence. Mathematics, in particular elementary number theory, provides such a background. Taking "successor of", not in the sense of an immediate successor, but in the sense of being greater than, Fauconnier asks if the following sentence is true in the theory of natural numbers.

(33) Some successor of every even number is a multiple of some successor of every odd number.

To see that this is true, let \underline{e} be an even number and \underline{o} an odd number. $e(o+1)$, which is a successor of \underline{e} , is a multiple of $o+1$, which is a successor of \underline{o} . On Hintikka's interpretation \underline{e} and \underline{o}

can be picked independently of one another and the relation of being a multiple of will be satisfied. But this is false: if $f(e)$ is a successor of \underline{e} , it cannot be a multiple of any \underline{o} greater than $f(e)$. Hence whatever one picks as a function which yields successors for the denotation of the word "successor" in the phrase "some successor of every even number" must be a function of both the even and odd numbers picked; but the function one picks which yields successors for the denotation of the word "successor" in the phrase "some successor of every odd number" need be a function of only the odd numbers picked. But QR provides such a reading, namely the reading whose representation has the same form as (25) above. To see this, recall that the corresponding formulae in Figures 2 and 3 are logically equivalent; now, let the two-place successor function above correspond with "f" and the one-place successor function above correspond with "g" in the schema (25) of Figure 3. Finally, a reading which has a representation whose form is the same as that of (26) is easily got from (33):

(34) Some successor of every even number is
a factor of some successor of every odd number.

6.3.2 Another Case for Representation by Branching Quantifiers

The same considerations just adduced with regard to Hintikka's first sentence (1.1), apply, by parity of reasoning, to his second sentence (1.2), repeated below for the reader's convenience.

(35) Some relative of every villager and some relative of every townsman hate each other.

If the reading ascribed by Hintikka to (35) is correct, then each of the following analogues of (35) should be false.

(36)

1. Some son of every village-father and some daughter of every town-mother are married to each other.
2. Some chord of every circle and some chord of every ellipse are parallel to each other.

But, they are true. (36.1) is true when the form of its representation is the same as (29); and (27.2) is true when the form of its representation is the same as either (29) or (28). But these are the representations which are licensed by QR.

Moreover, it is not even clear how Hintikka expects to represent (35). The following will not do.

(37)

$$\begin{array}{l} (\forall x: \text{townsman } x)(\exists y: y \text{ relative of } x) \\ (\forall v: \text{villager } v)(\exists w: w \text{ relative of } v) \end{array} \bigg\rangle y \text{ hates } w$$

But this fails to express the fact that "w hates y" is true

whenever "w hates y". This lacuna can be filled:

(38)

$(\forall x: \text{townsman } x)(\exists y: y \text{ relative of } x) \bigg\rangle (y \text{ hates } w \wedge w \text{ hates } y)$
 $(\forall v: \text{villager } v)(\exists w: w \text{ relative of } v) \bigg\rangle$

But this won't work, for as Langendoen (1978) has shown, the effect of the interpretation of the reciprocal pronoun on the interpretation of the verb to which it is an argument cannot be cashed out as a reciprocal relation (i.e., a relation which holds for all distinct pairs) on a set of individuals. (See 4.3.2 above and the discussion of examples (19) - (34) in 5.1 above.)

In contrast, the semantic and syntactic principles adopted or developed in the earlier parts of the thesis provide a straightforward analysis of (35). A detail by detail presentation of such an analysis, though available, would be tedious, in light of the sheer complexity of the sentence. However, the sketch of such an analysis, which is to be given, should make evident how the details can be filled in. First, what is its syntactic structure? At DS, it has the following phrase marker.

(39)

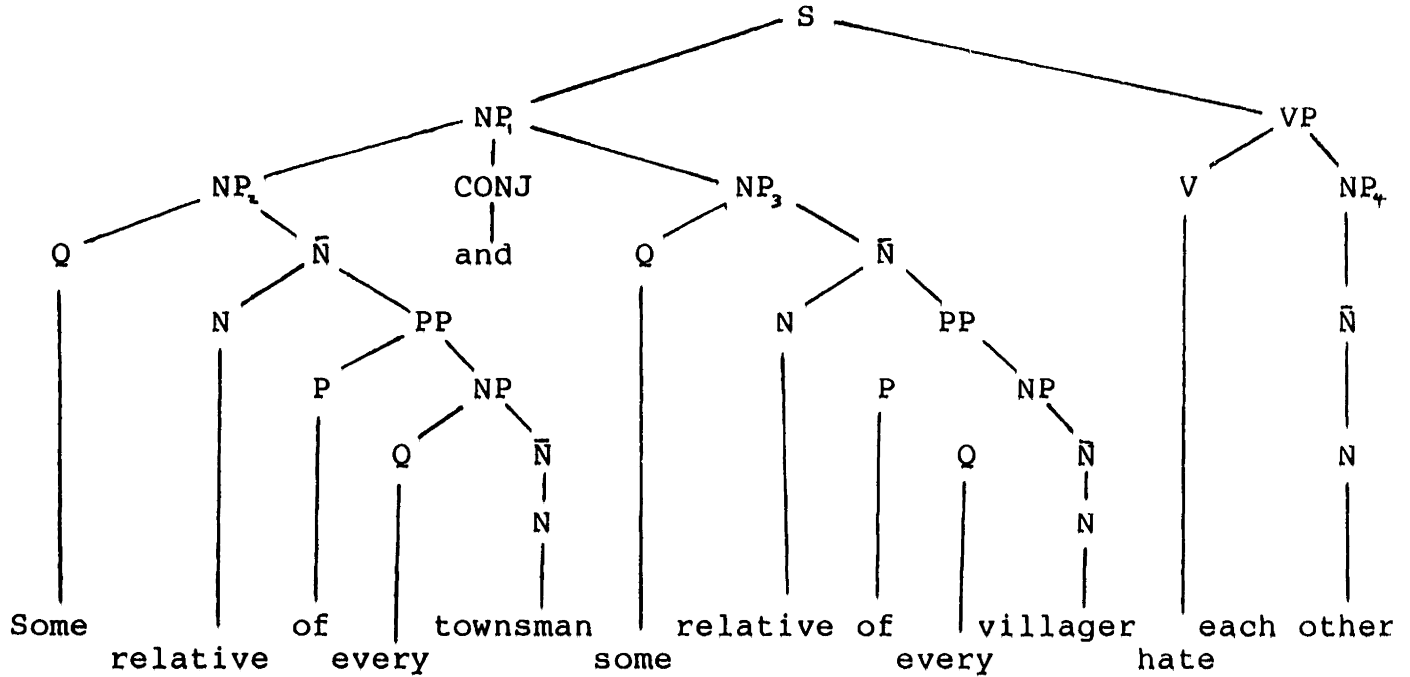

The mapping to SS is trivial, for there is nothing requiring movement. At SS, though, the node NP_4 must be linked. NP_4 can be linked to only one node, if the conditions at SS are to be met, namely, NP_1 . (For details, see the discussion of (26) in 5.1 above.) The mapping to LF is not trivial: there are six distinct configurations which can result from QR. I shall consider only one.

(40)

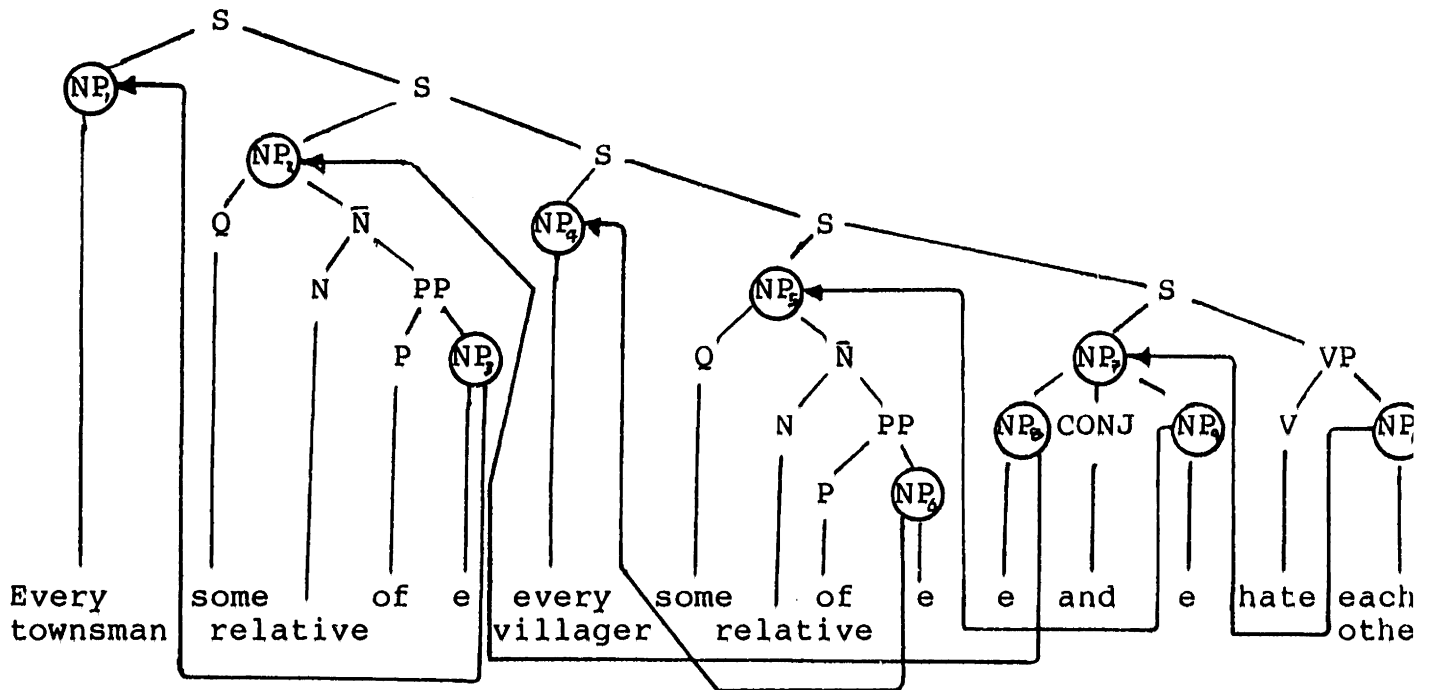

The interpretation of (40) requires the interpretation of quantifiers (some, every), non relational count nouns (townsman, villager), a relational count noun (relative), a reciprocal pronoun (each, other), and a verb (hate). Principles for the interpretation of each of these items have been stated. Thus relative is interpreted as a function from subsets of the domain into subsets of its extension. The function receives its values from the interpretation of its internal argument position. Each of these values is a singleton (if the function is well-defined in the domain), since the noun phrase nodes NP₃ and NP₂ (NP₆ and NP₇) have the feature -PL. The values which are the

interpretation of NP_3 (NP_3') are those assigned by the restricted quantifier NP_1 (NP_4) which binds it. Continuing from the bottom to the top of NP_2 (NP_5), one sees that the interpretation of Q in NP_1 (NP_5) takes each singleton assigned to its sister \bar{N} and assigns it to NP_3 (NP_4). Again these values will be singletons in view of the fact that NP_3 (NP_4) has the feature $-PL$. Finally, the interpretation of VP , which is essentially the characteristic function of the reciprocal relation of mutual hatred, is assigned exactly a pair of singletons. Each singleton in this pair is ultimately a function of each singleton assigned by the interpretation of the restricted quantifiers NP_1 and NP_5 respectively.

6.4 Conclusion

The upshot of this re-assessment of Hintikka's case for branching quantifiers as a proper representation for quantificational aspects of the sentences discussed above is this. First, he provides no grounds for determining the relation of scope among the quantifiers of a sentence containing more than one quantifier. Second, he fails to provide grounds for choosing branching representations of quantifiers over logically equivalent but non-branching representations, be they second order equivalents or first order ones. Moreover, as Fauconnier

has shown, there is good evidence to question Hintikka's judgements. And, as I showed above, this evidence is borne out by the rule for the assignment of scope to quantifiers (i.e., the mapping from SS to LF). Thus, while Hintikka provides one with a gloss of the sentences discussed in this chapter, a gloss which is doubtful, the theory developed or adopted here provides a complete syntactic and semantic analysis of them.

FOOTNOTES - CHAPTER SIX

1. See Saarinen (ed) 1979.
2. (5) is derived from (4) and, in general, a formula in prenex normal form is derived from one not in such a form -- by the meta-theoretical fact that formulae which are alphabetic variants of one another are logically equivalent and from the following theorems (where "p" is any formula not containing the variable "x").
 1. $(p \rightarrow \exists x Fx) \leftrightarrow \exists x (p \rightarrow Fx)$
 2. $(p \rightarrow \forall x Fx) \leftrightarrow \forall x (p \rightarrow Fx)$
 3. $(\forall x Fx \rightarrow p) \leftrightarrow \exists x (Fx \rightarrow p)$
 4. $(\exists x Fx \rightarrow p) \leftrightarrow \forall x (Fx \rightarrow p)$
3. Of course, " $\forall v \exists w \forall x \exists y Fxyvw$ " is the other possible formula made from the same parts. But for what I am about to say, it makes no difference which one is considered.
4. Saarinen (ed) 1979: 67.
5. There are some minor alterations of what Hintikka actually says which I have availed myself of but which do not affect the point I am making. First, in the citation, I have substituted my numbering for his. Second, Hintikka's example of (21) actually has "not shown any" instead of "shown all". However, in treating his actual example, he claims that the occurrence of "not" in his original example does not militate against his claim of ambiguity in the sentence, since the ambiguity obtains in sentences like my (21). The reader must conclude, then, that the point being made carries over, mutatis mutandis, to my (21).
6. Ibid. 69.
7. I have taken the liberty of using generalized quantifiers in Hintikka's representation. Since the quantifiers in this example are existential and universal, the representations are equivalent to those with simple universal and existential quantifiers.

CONCLUSION

What, then, may one conclude from the foregoing chapters about the form of representation for the quantificational aspects of the sentences in the class surveyed? One concludes: first, that the class of quantifiers in English is bounded, being limited to a dozen or so determiners and a few pronouns lexically derived from some of the determiners; second, that the quantifiers are restricted first order quantifiers; and third, that scope, which is defined in terms of c-command, is a total ordering of quantifier noun phrases in a phrase marker (of the sentences surveyed) at LF.

These results are at odds with those who claim that among the sentences surveyed there are ones requiring branching quantifiers and ones requiring second order quantifiers. The third result conflicts with Hintikka's claim that the two sentences treated in the last chapter have quantified noun phrases which are only partially ordered with respect to one another in their logical form. As was shown, however, Hintikka's construal of the pair of sentences adduced is persuasively impugned by Fauconnier (1975) and the construal of Fauconnier sustained by the rule of QR (i.e., the mapping from SS to LF), introduced by May (1977). The second result conflicts with the

claim, implicit in Langendoen (1978) and explicit in Lauri Carlson (1982), that plural noun phrases require second order quantifiers for their proper representation.

The type of argument used by Carlson (1982: Part I, Sect. 2 and Appendix 1) and others runs as follows. A sentence in English is represented by a formula of second order logic. The implicit claim is that the sentence and the second order formula are true in all and only the same models, hence they are logically equivalent. Then, the second order formula is shown to have no first order equivalent, in particular, that there is at least one model in which the second order formula is true but in which no first order formula is true. From this, it follows that the sentence has no first order formula logically equivalent to it. But the argument is misleading.

It is well known, for example, that set theory can be axiomatized either in a first order language or in a second order language. However, for the axiomatizations to be logically equivalent parameters of the formulation in a first order language must be set. Typically, this means that the quantifiers must range at least over classes (in the sense of Von Neumann) and that two distinct two-place predicates must be set as equality and membership. Similarly, elementary number theory can

be axiomatized either in a first order language or in a second order language. Again, logical equivalence can be attained only when some of the parameters of the first order language are set. (See Enderton 1972: 67-72.) The most the type of argument is entitled to conclude is that the formula of first order logic none of whose parameters are fixed is logically equivalent to the sentence in question.

But even this qualified conclusion may be too much. Notice that an essential step in the argument above is to find a second order formula which is logically equivalent to the sentence in question. The conclusion is persuasive only insofar as the gloss in second order logic is equivalent to the given sentence. But as was seen at several different points in the thesis, judgements of the range of interpretation of a sentence can result either from grammatical considerations (i.e., syntactic and semantic) or from conceptual or doxic considerations. Thus, it was argued that a sentence like "an oak grew from every acorn" has two, logically distinct phrase markers at LF, though it seems to have only one. (See the discussion of (39) in 1.2.3 above.) It was also argued that, contrary to appearances, sentences like "the man surrounded the town" are grammatical (i.e., syntactically and semantically well-formed), though conceptually and doxically odd. The upshot of these considerations is that the glossing of

a sentence by a formula, be it first, second, or whatever order, is just not compelling in the absence of a more comprehensive syntactic and semantic theory.

So, what would be compelling? What would be compelling would be to show that the very characteristic which distinguishes a second order language from a first order one is found in the proper representation of the logical form of a sentence in some language. (See 1.0 above.) But what is the characteristic? It is a syntactic one: in a first order language, positions in which bindable items occur are only argument positions; in a second order language, predicate positions are bindable too. Is there a sentence whose predicate can be bound? Surely, if anything is a predicate in natural language, it is the verb phrase. If verb phrases in English could be bound, one would expect, as Higginbotham has pointed out, to find sentences like:

1.1 The men somewhat

1.2 The entertainer everythings

(where "somewhat" is a verb meaning "does something" and "everything" is a verb meaning "does everything".) But no language is known to have such verbs, or verb phrases. In fact, on the view adopted or developed in this thesis for the class of sentences treated, there is a natural definition of "predicate":

it is any syntactic expression whose distinguished argument is unsaturated (i.e., unassigned within the expression). Such expressions are adjectives (as well as adjective phrases) and verbs (as well as verb phrases). But such expressions are never bound, and probably is for the class of sentences examined. One concludes, then, that these sentences do not, in any linguistically pertinent sense, have second order quantifiers.

BIBLIOGRAPHY

- Abbott, James C. 1969 Sets, Lattices, and Boolean Algebras. Boston, Massachusetts: Allan and Bacon, Inc.
- Barwise, Jon 1979 "On Branching Quantifiers in English". Journal of Philosophical Logic: vol. 8, pp. 47 - 80.
- Barwise, Jon and Cooper, Robin 1981 "Generalized Quantifiers and Natural Language". Linguistics and Philosophy: vol. 4, no. 2, pp. 159 - 220.
- Birkhoff, Garrett 1943 "What is a Lattice?" American Mathematical Monthly: vol. 50, pp. 484 - 487.
- Bouchard, Denis 1982 On the Content of Empty Categories. Massachusetts Institute of Technology: unpublished Ph.D. dissertation.
- Carlson, Greg N. 1977 "A Unified Analysis of the English Bare Plural". Linguistics and Philosophy: vol. 1, pp. 413 - 457.
- Carlson, Lauri 1982 Plural Quantification. Unpublished ms.
- Chomsky, Noam 1965 Aspects of the Theory of Syntax. Cambridge, Massachusetts: The MIT Press.
- Chomsky, Noam (ed) 1968 Language and Mind. New York, New York: Brace, Harcourt, and Jovanovich Inc., 2nd ed. (revised and enlarged) 1972.
- Chomsky, Noam 1976 Reflections on Language. New York, New York: Random House (Pantheon Books).
- Chomsky, Noam (ed) 1977 Essays on Form and Interpretation. Amsterdam, Holland: Elsevier North-Holland, Inc. (Studies in Linguistic Analysis).
- Chomsky, Noam 1980 Rules and Representations. New York, New York: Columbia University Press.
- Chomsky, Noam 1981 Lectures on Government and Binding. The Pisa Lectures. Dordrecht, Holland: Foris Publications (Studies in Generative Grammar), 2nd ed. (revised) 1982.

- Culicover, P. W., Wasow, T., Akmajian, Adrien (eds) 1977 Formal Syntax. New York, New York: Academic Press, Inc.
[Proceedings of the 1976 Mathematics and Social Science Board -- University of California at Irvine -- Conference on the Formal Syntax of Natural Language.]
- Enderton, Herbert B. 1970 "Finitely Partially-Ordered Quantifiers". Zeitschrift fur Mathematische Logik und Grundlagen der Mathematik: vol. 16, pp. 393 - 397.
- Enderton, Herbert B. 1972 A Mathematical Introduction to Logic. New York, New York: Academic Press, Inc.
- Evans, Gareth 1980 "Pronouns". Linguistic Inquiry: vol. 11, no. 2, pp. 337 - 362.
- Fauconnier, Gilles 1975 "Do Quantifiers Branch?" Linguistic Inquiry: vol. 6, no. 4, pp. 555 - 578.
- Fiengo, Robert and Lasnik, Howard 1973 "The Logical Structure of Reciprocal Sentences in English". Foundations of Language: vol. 9, pp. 447 - 468.
- Fodor, Janet Dean and Sag, Ivan A. 1982 "Referential and Quantificational Indefinites". Linguistics and Philosophy: vol. 5, pp. 335 - 398.
- Fiengo, Robert and Lasnik, Howard 1976 "Some Issues in the Theory of Transformations". Linguistic Inquiry: vol. 7, no. 1, pp. 182 - 191.
- Gabbay, Dov and Guenther, Franz (eds) 1985 Handbook of Philosophical Logic. Dordrecht, Holland: D. Reidel Publishing Co. (Synthese Language Library).
- Gericke, Helmuth 1963 Theorie der Verbände. Mannheim, West Germany: Bibliographisches Institut A. G. Mannheim.
- Hailperin, T. 1957 "A Theory of Restricted Quantification". The Journal of Symbolic Logic: vol. 22, no. 1, pp. 19 - 25; no. 2, pp. 113ff; vol. 25, no. 1 (1960), pp. 54 - 56.
- Harrap, George C. (tr) 1966 Lattice Theory. New York, New York: Fredrick Ungar Publishing Co. [Translation of: Gericke, Helmuth 1963.]

- Helke, Michael 1971 The Grammar of English Reflexives.
Massachusetts Institute of Technology: unpublished Ph.D.
dissertation.
- Henkin, Leon 1959 "Some Remarks on Infinitely Long Formulas".
In: Panstwowe Wyndawnictwo Naukowe (ed) 1961, pp. 167 -
183.
- Higginbotham, James 1981 "Reciprocal Interpretation". Linguistic
Research: vol. 3, no. 1, pp. 97 - 117.
- Higginbotham, James 1983 "LF, Binding, and Nominals". Linguistic
Inquiry: vol. 14, no. 3, pp. 395 - 420.
- Hintikka, Jaakko 1973 "Quantifiers Versus Quantification".
Dialectica: vol. 27, pp. 329 - 358. [Also in:
Linguistic Inquiry: vol. 5, no. 2 (Spring, 1974), pp.
153 - 177.] [Reprinted in: Saarinen (ed) 1979, pp. 49 -
81.]
- Huang, James Chang-Teh 1982 Logical Relations in Chinese and the
Theory of Grammar. Massachusetts Institute of
Technology: unpublished Ph.D. dissertation.
- Ioup, Georgette 1977 "Specificity and the Interpretation of
Quantifiers". Linguistics and Philosophy: vol. 1, pp.
233 - 245.
- Jackendoff, Ray 1977a "Constraints on Phrase Structure Rules".
In: Culicover, P. W., et al. (eds) 1977, pp. 249 - 283.
- Jackendoff, Ray 1977b X Syntax: A Study of Phrase Structure.
Cambridge, Massachusetts: The MIT Press (Linguistic
Inquiry: Monograph 2).
- Jespersen, Otto 1909 A Modern English Grammar on Historical
Principles. 7 vols. London, England: George Allen and
Unwin, Ltd. 1965.
- Kaplan, David 1966a "Rescher's Plurality-Quantification". The
Journal of Symbolic Logic: vol. 31, pp. 153 - 154.
- Kaplan, David 1966b "Generalized Plurality Quantification". The
Journal of Symbolic Logic: vol. 31, pp. 154 - 155.
- Kroch, Anthony 1974 The Semantics of Scope. Massachusetts
Institute of Technology: unpublished Ph.D.

dissertation.

- Langendoen, D. Terence 1978 "The Logic of Reciprocity".
Linguistic Inquiry: vol. 9, no. 2, pp. 117 - 197.
- Levi, Judith 1978 The Syntax and Semantics of Complex Nominals.
New York, New York: Academic Press, Inc.
- Lewis, Harry R. and Papadimitriou, Christos H. 1981 Elements of the Theory of Computation. Englewood Cliffs, New Jersey: Prentice-Hall, Inc. (Prentice-Hall Software Series).
- Lyons, John 1977 Semantics. 2 vols. Cambridge, England: Cambridge University Press.
- Maling, Joan 1976 "Notes on Quantifier Postposing". Linguistic Inquiry: vol. 7, no. 4, pp. 708 - 718.
- May, Robert C. 1977 The Grammar of Quantification. Massachusetts Institute of Technology: unpublished Ph.D. dissertation.
- Mostowski, Andrej 1957 "On a Generalization of Quantifiers".
Fundamenta Mathematica: vol. 44, pp. 12 - 36.
- Panstwowe Wydawnictwo Naukowe (ed) 1961 Infinitistic Methods.
Warsaw, Poland: Panstowowe Wydawnictwo Naukowe
(Proceedings of the Symposium on Foundations of Mathematics, Warsaw, 2-9 September 1959). [Also: London, England: Pergamon Press, 1961.]
- Pelletier, Francis Jeffrey and Schubert, Lenhart K. 1984 "Mass Expressions". To appear in: Gabbay, Dov and Guenther, Franz (eds) 1985.
- Postal, Paul 1974 On Raising One Rule of English Grammar and its Theoretical Implications. Cambridge, Massachusetts: The MIT Press (Current Studies in Linguistics: vol. 5) 1979.
- Postal, Paul 1976 "Avoiding Reference to Subject". Linguistic Inquiry: vol. 7, no. 1, pp. 151 - 191.
- Quirk, Randolph, Greenbaum, Sidney, Leech, Geoffrey, Svartik, Jan 1972 A Grammar of Contemporary English. London, England: The Longman Group, Ltd.

- Radford, Andrew 1981 Transformational Syntax. A Student's Guide to Chomsky's Extended Standard Theory. Cambridge, England: Cambridge University Press (Cambridge Textbooks in Linguistics) reprinted 1982.
- Reinhart, Tanya 1976 The Syntactic Domain of Anaphora. Massachusetts Institute of Technology: unpublished Ph.D. dissertation.
- Rescher, Nicholas 1962 "Plurality-Quantification". The Journal of Symbolic Logic: vol. 27, no. 3, pp. 373 - 374. [Reprinted in: Rescher (ed) 1968, pp. 170 - 172.]
- Rescher, Nicholas (ed) 1968 Studies in Logical Theory. Oxford, England: Basil Blackwell (American Philosophical Quarterly: Monograph Series no. 2).
- Rosser, J. Barkley 1953 Logic for Mathematicians. New York, New York: McGraw-Hill Book Co., Inc. (International Series in Pure and Applied Mathematics) 1953.
- Rutherford, Daniel E. 1965 Introduction to Lattice Theory. London, England: Oliver and Boyd (University Mathematical Monographs).
- Saarinen, Esa (ed) 1979 Game Theoretical Semantics: Essays on Semantics by Hintikka, Carlson, Peacocke, Rantala, and Saarinen. Dordrecht, Holland: D. Reidel Publishing Co. (Synthese Language Library; vol. 5).
- Selkirk, Elizabeth O. 1977 "Some Remarks on Noun Phrase Structure". In: Culicover, P. W. et al. (eds) 1977 pp. 285 - 316.
- Staal, J. F. 1960 "Contraposition in Indian Logic". Proceedings of the 1960 International Congress for Logic, Methodology, and Philosophy of Science: 1962 pp. 634 - 649.
- Stowell, Timothy Angus 1981 Origins of Phrase Structure. Massachusetts Institute of Technology: unpublished Ph.D. dissertation.
- Trudeau, Richard J. 1976 Dots and Lines. Kent, Ohio: Kent State University Press.

- Walkoe, Wilbur J. 1970 "Finitely Partially-Ordered Quantification". The Journal of Symbolic Logic: vol. 35, no. 4, pp. 535 - 555.
- Wall, Robert 1972 Introduction to Mathematical Linguistics. Englewood Cliffs, New Jersey: Prentice-Hall, Inc.
- Williams, Edwin 1981 "Argument Structure and Morphology". The Linguistic Review: vol. 1, pp. 81-114.
- Wilson, Robin J. 1972 Introduction to Graph Theory. London, England: Longman Group Ltd., 2nd ed. 1979.

BIOGRAPHICAL NOTE

Brendan S. Gillon was born in Boston, Massachusetts on May 16, 1950. While pursuing his B.A. at The University of Michigan, which he took in the area of Chinese Language and Literature in April of 1971, he developed interests in philosophy and language. Upon completion of course work for an M.A. in East Asian Studies, also at The University of Michigan, he spent two years in Taipei, Taiwan enhancing his competence in Mandarin and Classical Chinese and pursuing his interests in Classical Chinese philosophy and mathematics. He completed his M.A. in the summer of 1976, having embarked on a second in Sanskrit and Indian Studies at the University of Toronto. This second M.A. was acquired after he had spent a year at the University of Poona, improving his grasp of Sanskrit and pursuing his interests in Classical Indian philosophy and mathematics. In 1979 he entered the doctoral program in the Department of Linguistics and Philosophy at the Massachusetts Institute of Technology, which he completed in the summer of 1984. His publications up to that point include:

"Introduction, Translation, and Discussion of Chao Chün-ch'ing's 'Notes to the Diagrams of Short Legs and Long Legs of Squares and Circles'". Historia Mathematica: v. 4 (1977), 253-293.

(Joint author with Martha Lile Love) "Indian Logic Revisited" Nyāyapraveśa Reviewed". Journal of Indian Philosophy: v. 8 (1980), 349-384.

(Joint author with Richard P. Hayes) "The Role of the Particle eva in Logical Quantification in Sanskrit". Wiener Zeitschrift für die Kunde Südasiens: v. 26 (1982), 195-203.

"Dharmakīrti and his Theory of Inference". To appear in an anthology on Buddhist logic edited by Prof. Matilal.