

TONE IN LEXICAL PHONOLOGY

by

Douglas George Pulleyblank

B.A. University of Ibadan
(1977)

Submitted to the Department of
Linguistics and Philosophy
in Partial Fulfillment of the
Requirements of the
Degree of

DOCTOR OF PHILOSOPHY

at the

MASSACHUSETTS INSTITUTE OF TECHNOLOGY

May 1983

© Douglas Pulleyblank 1983

The author hereby grants to M.I.T. permission to reproduce and to
distribute copies of this thesis document in whole or in part.

Signature of Author _____
Department of Linguistics and Philosophy
May 27 1983

Certified by _____
Paul Kiparsky
Thesis Supervisor

Accepted by _____
Samuel Jay Keyser
Chairman, Departmental Committee
MASSACHUSETTS INSTITUTE OF TECHNOLOGY

AUG 1 1983 Hum.

LIBRARIES

TONE IN LEXICAL PHONOLOGY

by

Douglas Pulleyblank

Submitted to the Department of Linguistics and Philosophy
on 27 May 1983 in partial fulfillment of the requirements of
the Degree of Doctor of Philosophy

ABSTRACT

This thesis examines certain issues of tonal phonology within the theory of lexical phonology. Tonal phenomena require the enrichment of the lexical framework to include a post-lexical phonetic component. This component is shown to play a crucial role in accounting for the array of phenomena known as downdrift/downstep.

By separating phonological processes from phonetic processes, and by distinguishing between two classes of phonological processes -- namely, those that apply lexically and those that apply post-lexically -- we move towards an understanding of why particular tonal rules exhibit the properties that they do. For example, phonological constraints on autosegmental linkings may hold of rules applying lexically, but not of rules applying post-lexically -- or such constraints may hold of rules applying lexically and post-lexically, but not phonetically.

The role of underspecification in tonal phonology is investigated. It is proposed that when rules of linking, spreading, etc. have not supplied any given tone-bearing unit with a tone, then a tonal autosegment is assigned by universal default rules. It is proposed that such universal default rules cannot be extrinsically ordered with respect to language-specific phonological rules. Once their allocation to the lexical, syntactic or phonetic component has been determined, the ordering of default rules is predicted by general principles.

Central to the approach taken in this thesis is a revised set of tonal association conventions, where spreading of tones onto free tone-bearing units is not automatic. Spreading takes place by language-specific rule only. A number of the consequences of this revision are investigated. In particular, it is shown that accentual diacritics can be eliminated as a device for determining the location of tonal melodies.

As a final theoretical point, it is shown that the notion of 'extrametricality' is required for tone, as well as for stress. Moreover, it is shown that 'extrametrical' tonal constituents obey the same 'Peripherality Condition' that has been proposed as a constraint on extrametricality in stress systems.

The evidence presented in this dissertation is drawn from a number of languages, including the following: Dschang-Bamileke, Margi, Tiv, Tonga and Yoruba.

Thesis Supervisor: Paul Kiparsky

Title: Professor of Linguistics

ACKNOWLEDGEMENTS

Writing this thesis has been like living in the vortex of a whirlpool. Topics, ideas, analyses, criticisms have developed the unnerving habit of throwing themselves at me with ever increasing speed over the past four years. Perhaps the most important thing I have learned at MIT is how to duck.

To Paul Kiparsky, my advisor, and to Morris Halle, I owe a major debt. It has been a great privilege to work on phonology with both of them. They have put considerable time and effort into helping me figure out what Linguistics is all about, and hopefully that effort has (at least to some extent) paid off. A special thanks is also due to the third member of my committee, Ken Hale. He taught me to have a lot of respect for language -- and on the way, a fair bit about syntax.

Diana Archangeli and K.P. Mohanan deserve special recognition. Both submitted peacefully (on the whole) to my demands that they devote considerable time and attention to matters of tonal phonology. I am glad that they did.

One of the best things about MIT is the discussion that only rarely allows Building 20 to sleep. To the following people, I owe a lot: Joan Bresnan, Maggie Browning, Denis Bouchard, Noam Chomsky, Nigel Fabb, Mohand Guerssel, Mike Hammond, Jim Harris, Jim Huang, Jay Keyser, Mary Laughren, Juliette Levin, Lori Levin, Mario

Montalbetti, Bill Poser, Paula Pranka, Malka Rappaport, Anne Rochette, Susan Rothstein, Mamoru Saito, Jane Simpson, Lisa Travis, Jan Wager and Meg Withgott.

Special thanks also goes to a number of people who gave freely of their knowledge of a wide variety of tonal systems: Akin Akinlabi, Mary Clark, Nick Clements, Larry Hyman, Jonathan Kaye, Will Leben, David Odden, Martha Wright and Moira Yip.

For proofreading, thanks to Diana Archangeli, Jeri Kisala, Tara Mohanan, Tova Rapoport, Lisa Travis and Betsy Walli. And for the use of their Rapidograph pens, thanks to Diana and Dante Archangeli.

When I went to the University of Ibadan as an undergraduate, I was a long way from being sure that Linguistics was the right field for me. (And one wonders about the long-range implications of being the only student who did not speak a tone language ...) The professors both at the University of Ibadan and at the University of Ilorin played a major role in heading me down the road that has led to this dissertation. Thanks especially to Wale Adeniran, Dele Awobuluyi, 'Yiwola Awoyale, Ayo Bamgbose, Ben Elugbe, Carl Hoffmann, Mona Lindau-Webb, Yasuko Nagano, Bisi Ogunsina, Chief Olajubu, Klaus Schubert and Kay Williamson.

I owe a special debt to Sammy Chumbow, who refused to give me letters of recommendation into graduate school, unless I applied to MIT.

While at MIT, my work has been partially supported by a doctoral fellowship from the Social Sciences and Humanities Research Council of Canada.

Finally, thanks to my parents for always encouraging me even when what I was doing seemed a little unorthodox. And to Anne-Marie, Cato and Ingrid -- I'm sure glad you were there.

O sweet: spontaneous
earth how often have
the
doting

fingers of
prurient philosophers pinched
and
poked

thee
, has the naughty thumb
of science prodded
thy

beauty . how
often have religions taken
thee upon their scraggy knees
squeezing and

buffeting thee that thou mightest conceive
gods
(but
true

to the incomparable
couch of death thy
rhythmic
lover

thou answerest

them only with

spring)

e.e. cummings

TABLE OF CONTENTS

	<u>Page</u>
ABSTRACT	2
ACKNOWLEDGEMENTS	4
CHAPTER 1: INTRODUCTION	13
1. Lexical Phonology	13
1.1 Strata	15
1.2 The Cycle	17
1.3 Bracket Erasure	21
1.4 The Model	23
1.5 Stratum Domain Hypothesis	24
1.6 Lexical Exceptions	24
1.7 Structure Preservation	24
1.8 Summary	25
1.9 Phonetic Rules	25
2. Tiered Phonology	28
2.1 Association Conventions	28
2.2 When do the Conventions Apply?	32
2.3 Linking of Tiers	34
2.4 Default Values and the "Phonemic Core"	38
2.5 Extratonicity	44
2.6 Final Remarks	45
3. Tone and Lexical Phonology	45
3.1 Where are Tones Assigned?	46
3.2 Cyclic Tone Association	47
3.3 Constraints on Linkings	52
3.4 Lexical vs. Post-lexical	52
3.5 Underspecification	53
4. Layout of Chapters	54
5. Formal Notation	55
FOOTNOTES	57

CHAPTER 2: DOWNSTEP	60
1. The Phenomenon of Downstep	60
2. The Overall Model	63
3. Phonetic Variation	65
4. Phonetic Models	70
4.1 Constituency	70
4.2 Exponential Decay	72
4.3 Exponential Decay vs. Trees	73
5. Dschang-Bamileke	77
5.1 Background	78
5.2 Downstep in the Associative Construction	83
5.2.1 Associative Deletion	84
5.2.2 H-spread (Dschang)	87
5.3 Downstepped L-tones	88
5.4 L-deletion	91
5.4.1 A Problem Case	93
5.5 Summary of Rules	95
5.6 Post-lexical Application	96
5.7 Phrasal L-deletion	99
5.8 H-deletion	101
5.9 A Residual Problem	103
5.10 Other Analyses	104
5.11 Conclusions	108
FOOTNOTES	109
CHAPTER 3: UNDERSPECIFICATION	112
1. Default Rules	113
2. Yala Ikom Reduplication	117
3. Yoruba	120
3.1 L-tone Deletion	121
3.2 V-deletion	122
3.3 High Tone Concord	136
3.4 Conclusions	139
3.4.1 Default Value	140

3.4.2	Core Values vs. Autosegments	141
3.4.3	Association Conventions	141
3.4.4	Post-lexical Default Rules	142
4.	Three-way Contrasts with Two Tones	142
5.	Tonal Features	144
6.	Binary vs. Ternary Features	147
6.1	Tone is Not Ternary	151
6.2	Constraints on Underspecification	157
6.2.1	Referring to Unmarked Values	158
6.2.2	Constraints	160
6.3	Default <u>L</u> vs. Default <u>M</u>	165
7.	Conclusion	167
	FOOTNOTES	168
CHAPTER 4: ACCENT		172
1.	Diacritics	173
2.	Pre-linking	176
3.	"Culminative" Function	177
4.	Distributional Constraints	179
5.	Melodies	180
6.	Symmetry	184
7.	Luganda	185
8.	Tonga	189
8.1	Verb Bases	194
8.2	Initial H-deletion	195
8.3	Downstep Creation	196
8.4	Meeussen's Rule	197
8.4.1	Rule Application	204
8.5	Accent Shift	206
8.6	Hortative Affirmative	213
8.7	Remote Dependent Affirmative	221
8.8	Conclusion	224
	FOOTNOTES	226

CHAPTER 5: EXTRATONALITY	228
1. Background to Margi	229
2. Suffixed Object Pronouns	233
3. Genitive Constructions	237
4. Polarity	240
4.1 Present Tense	240
4.2 Past Tense	240
4.3 Subject Clitics	241
4.4 Analysis	243
4.5 Present and Past Tenses (Again)	252
4.6 Dissimilation and Polarization Rules	254
5. Association Conventions	257
6. The Cycle	260
7. Conclusion	263
FOOTNOTES	264
CHAPTER 6: TIV	266
1. Downstep	267
1.1 H-spread	269
1.2 Downstep (Continued)	272
2. The Cycle	274
3. Automatic Spreading	276
3.1 Past Tense Forms	282
3.2 H-spread	287
3.3 Habitual 3	288
3.4 The Association Conventions (Revised)	292
3.5 An Alternative	293
4. Lexical Constraints	295
4.1 Contour Tones	296
4.2 Lexical Constraints (Continued)	304
5. Ordering	307
6. Derived vs. Non-derived	315
7. Default Rules	317
8. Lexical Exceptions	325

8.1	The Future Tense	325
8.2	!-deletion	327
9.	Extratonicity	332
9.1	Imperative	332
9.2	Subjunctive	337
10.	Morphological Encoding	340
10.1	Boundary Symbols	340
10.2	Variables	344
	APPENDIX	347
	FOOTNOTES	351
	REFERENCES	357

CHAPTER 1: INTRODUCTION

The aim of this thesis is to investigate certain tonal problems within the framework of lexical phonology. The results bear primarily on two types of issues: 1) issues concerning the theory of lexical morphology and phonology. 2) issues concerning the theory of autosegmental phonology. In this chapter, I will present an overview of important aspects of the lexical and autosegmental theories. It will be shown that certain assumptions within one theory have direct consequences for the other theory. The basic results of this thesis -- which will be discussed in detail in subsequent chapters -- will be presented briefly in this chapter. In addition, a number of issues will be raised that bear directly on the topic of this dissertation, even though the evidence gathered has not been sufficient to resolve them.

1. Lexical phonology

In early generative treatments of phonology, such as that of Chomsky and Halle (1968) (henceforth SPE), the phonological component mapped surface syntactic structures onto a phonetic representation. This proposal was couched within a theory of syntax where word-formation was essentially a subset of the set of syntactic rules. That is, morphological operations could be performed by syntactic concatenations and transformations (see for

example, Chomsky 1957, Lees 1960). Since the morphological representation of a word was not determined until after the operation of syntactic rules, the phonology could not have access to a well-formed morphological string until after the syntactic component. So it was proposed in SPE that the set of phonological operations applied post-syntactically. With the (re-)emergence of a word-formation component (Chomsky 1970, Halle 1973, Aronoff 1976, etc.), it became necessary to re-evaluate the SPE position. One recent approach that has emerged from such a re-evaluation is the theory of lexical morphology and phonology proposed by Mohanan (1982) and Kiparsky (1982).

The theory of lexical phonology argues that there are two distinct types of phonological rule applications. The first is when rules apply within the lexicon (the 'lexical' phonology), while the second is when rules apply to the output of the syntactic component (the 'post-lexical', 'sentence-level' or 'phrasal' phonology). The reason for this bifurcation rests with the claim that the two types of phonological operations systematically differ in a number of interesting ways. That is, rules applying in one component of the grammar will manifest different properties than rules applying in another component. Following Mohanan (1982), I assume that there is a single set of phonological rules, but that any given rule in the set may be defined as applying lexically, post-lexically, or both lexically and post-lexically. Hence the same

rule might apply both lexically and post-lexically but manifest different properties in the two cases.

In the following sections, I will summarize briefly some of the properties that have been argued to hold of one or the other types of rule applications. Detailed non-tonal arguments for the various points mentioned are available in Mohanan (1982) and Kiparsky (1982) and in a number of references cited therein; arguments of a tonal nature for a number of the same points will be presented in this dissertation.

1.1 Strata

To propose that there is a close interdependency between certain phonological processes and certain morphological processes is not something new. Such an interdependency is discussed by many non-generative linguists such as Sapir (1921), Trubetzkoy (1929), Bloomfield (1933) and Martinet (1965). The problem has been how to represent such a dependency in a principled way. An important insight into this problem was made in the work of Siegel (1974, 1977) and Allen (1978). They showed that one could define the domain of certain phonological rules in terms of morphologically defined classes. They demonstrated moreover that the relevant classes of morphemes must be ordered in blocks.¹ That is, class 1 morphemes occur 'inside' (ie. closer to the stem than) class 2 morphemes, etc. Classes of morphemes triggering different sets of

rules do not occur arbitrarily interspersed amongst each other.

The observation that blocks of morphemes trigger particular sets of phonological rules can be encoded in a straightforward way, if we assume that phonological rules can actually apply inside the lexicon (Pesetsky 1979). Referring to the appropriate morpheme classes as 'levels' or 'strata', lexical phonology proposes that the output of a stratum of word-formation is submitted to the phonological rules assigned to the relevant stratum in the lexicon. This model can be represented schematically as follows (Mohanan 1982):

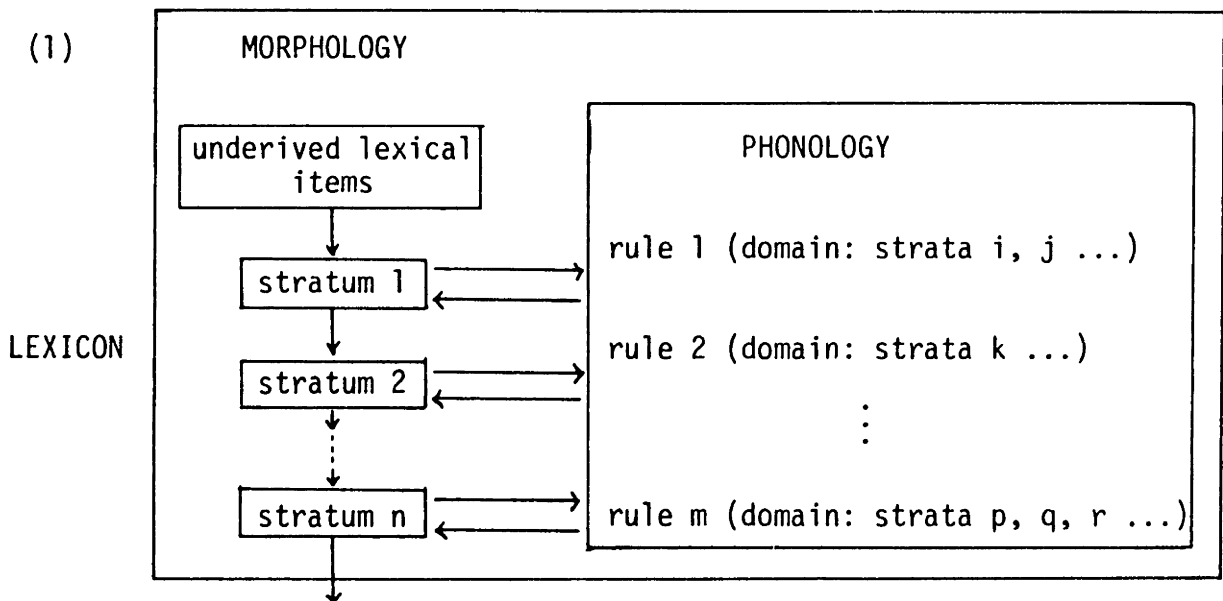

In the diagram in (1), we see that a lexical item can undergo affixation at any of a finite number of ordered strata defined for any given language. After affixation, the derived form is scanned by the phonological component, and all phonological rules applicable at the appropriate stratum (and whose structural descriptions are met) will apply to the derived string.

1.2 The Cycle

There are a number of ways in which rules could apply with respect to a particular stratum. In Pesetsky (1979), Mohanan (1982) and Kiparsky (1982), it was assumed that phonological rules apply to the output of every morphological process. And as noted in such work, this automatically encodes the phonological cycle into the structure of the lexicon. There is considerable evidence for the cyclic nature of lexical rules. In this thesis, for example, it is argued that lexical rules must apply cyclically in Tonga (chapter 4), Margi (chapter 5) and Tiv (chapter 6). It will be shown that cyclic rule application is crucial in such languages for an understanding of a variety of phenomena.

But while this thesis contributes to the evidence for the cycle, it should nevertheless be noted that recent work by Halle and Mohanan (in preparation) and Mohanan and Mohanan (1983) suggests that this may be an area of parametric variation. These papers raise the possibility that for some strata, phonological rules apply cyclically, while for other strata, all word-formation processes take place prior to a single application of the phonological rules defined for that stratum. Kiparsky (1983) suggests that such non-cyclic applications may be restricted to the last lexical stratum. He argues that a number of the properties observed for non-cyclic lexical rules fall out from the fact that the output of the last stratum is not itself re-entered into the lexicon.

The cyclic/non-cyclic parameter is argued to correlate with the applicability of the 'strict cycle' condition that has been proposed in earlier work on cyclic phonology (eg. Kiparsky 1974, Mascaro 1976, Halle 1978 and Rubach 1981). The notion of the 'strict cycle' is intuitively that a rule may only apply on any given cycle if its structural description has been derived on that cycle. Hence the English rule of Trisyllabic Shortening² will apply to the underlined vowel in (2a), while it will not apply to the underlined vowel of (2b).

- (2) a. opacity (cf. opaque)
 b. ivory

In opacity, the appropriate three-syllable sequence required by the rule of Trisyllabic Shortening is derived by the affixation of the suffix -ity] to the adjective opaque, hence the rule applies. In ivory, on the other hand, the structural description of Trisyllabic Shortening is met in the underlying representation, hence the rule does not apply.

While the precise formulation of the 'strict cycle' principle is not crucial here, examples such as the following are problematic.

- (3) a. column hymn
 [m] [m]
 b. columnar hymnal
 [mn] [mn]

- | | | |
|----|----------------------|------------------|
| c. | columns
[m] | hymn:
[m] |
| d. | column-shaped
[m] | hymn-book
[m] |

In such cases, we see that a rule of final n-deletion has applied to the (a), (c) and (d) cases. The rule of final n-deletion must apply after the stratum on which -al] and -ar] are added since otherwise * colu[m]ar and * hy[m]al would be derived.

- | | | |
|-----|----------------|------------|
| (4) | [colu[mn]] | Cycle 1: |
| | [colu[mφ]] | n-deletion |
| | [[colu[m]] ar] | Cycle 2: |
| | * colu[m]ar | |

On the other hand, final n-deletion must apply before morphological processes such as compounding and inflection since otherwise we would derive * hy[mn]-shaped and * hy[mn]s. These latter facts show that final n-deletion must be a lexical rule, since it applies prior to certain morphological processes. But the former facts show that final n-deletion cannot be on the same stratum as -al] and -ar] -- that is, the rule cannot (at least) be on the first stratum. Clearly, we are dealing with a lexical rule. And yet it appears that the rule applies on the appropriate stratum in a non-derived environment.

The solution proposed by Halle and Mohanan for such cases is that the stratum of English on which final n-deletion applies is a non-cyclic stratum. Consequently all affixes are added prior to the application of the relevant phonological rules, and such rules apply across-the-board.

Hence one class of rules applying within the lexicon in non-derived environments would be the class of rules applying in a non-cyclic stratum. There is also a second class of exceptions to the derived/non-derived distinction, namely the class of rules that 'build' structure. Kiparsky (1982) and Harris (1982) have shown that rules of syllabification and foot-assignment must apply even in non-derived environments on a cyclic stratum.

I have discussed the cyclic/non-cyclic distinction at some length for the following reason. It has been the general assumption in tonal phonology that tone association and tonal rules apply non-cyclically (CF: Goldsmith 1976, Clements and Ford 1979). In this thesis, I will show that tone association and tonal rules must be cyclic in a variety of languages. But if there exists in the lexicon a cyclic/non-cyclic parameter -- whether or not such a parameter is restricted to the last stratum -- then one would expect both cyclic and non-cyclic tone association. The crucial point is that this parameter would have nothing to do with tone per se. The adjustment of a single parameter -- whether phonological rules are scanned after every morphological process, or once only

after all morphological processes -- would affect all lexical phonological processes, including tone.

1.3 Bracket erasure

The theory of phonology sketched above allows a marked reduction in the power of phonological rules as concerns their ability to refer to morphological bracketing. Pesetsky (1979) proposes that inner morphological brackets are erased at the end of every pass through the lexical phonology. Although this is essentially the same convention proposed in SPE, its effect within lexical phonology is quite different. In SPE, morphology precedes phonology. Hence a convention of bracket erasure has a constraining effect only on the operation of phonological rules. Within lexical phonology, on the other hand, morphological processes at stratum n follow phonological processes at stratum n-1. Hence by erasing morphological brackets, we constrain not only the operation of phonological rules on subsequent strata, but also the operation of morphological rules. Following Mohanan (1982) and Kiparsky (1982), I will assume in this thesis that bracket erasure³ applies at the end of every stratum. I accept the arguments for weakening Pesetsky's position that are discussed in those papers, and refer the reader to them for details.

Note that an important result of bracket erasure is that any rule that refers to word-internal bracketing -- such as a rule

referring to a notion like 'stem', 'affix' or 'compound' -- must be a rule of the lexical phonology. Such bracketing will be unavailable to the post-lexical phonology since bracket erasure will apply at the end of the last stratum of the lexicon.

Also with respect to bracketing, note that any rule that applies across word-boundaries must be a post-lexical rule, since words are only concatenated into phrases at the point where post-lexically they are inserted into syntactic phrases. This follows from a theory of grammar along the following lines:

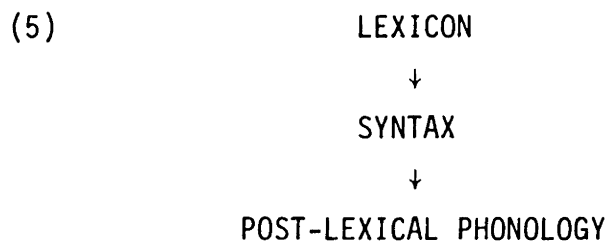

By assuming that phonological rules apply in either of two locations, pre-syntactically or post-syntactically, one need not stipulate that rules applying lexically may apply only word-internally and that rules applying post-lexically may apply across word-boundaries -- it follows from the organization of the grammar. It also follows from such a model that in any given derivation, all lexical applications of rules must precede all post-lexical applications of rules. For example, a rule applying across word-boundaries could never apply earlier in the derivation than a rule referring to sub-word constituents. ⁴

1.4 The Model

It should be stressed that the theory being summarized here does not prohibit a rule from applying both lexically and post-lexically. Rather, the claim is that when such cases arise, lexical applications of the rule will exhibit different properties than post-lexical applications of the same rule. Mohanan (1982) discusses a number of such cases. Hence a fuller picture of the relation between phonology, syntax and the lexicon is as in (6).

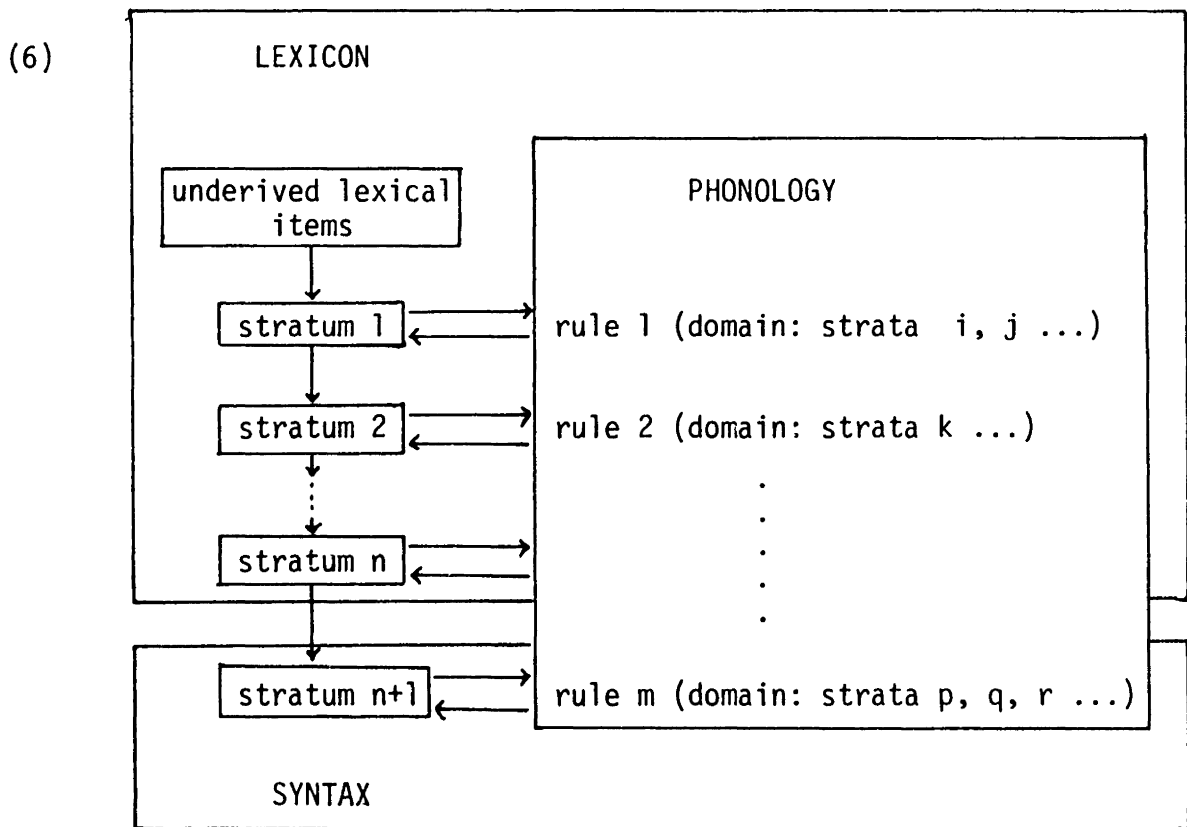

To the extent that the 'SYNTAX' in (6) is non-cyclic, this implies that the post-lexical phonology is also non-cyclic. ⁵

1.5 Stratum Domain Hypothesis

Rules may not apply on any arbitrary set of strata (including the post-lexical stratum) according to Mohanan. He argues for the following constraint:

(7) The domain of a rule is specified as a set of continuous strata.

Hence a rule could apply on all strata; on strata 1, 2, 3 and not, say, stratum 4; etc. A rule could not, however, apply on stratum 1 and stratum 3, but not stratum 2.

1.6 Lexical exceptions

It has been suggested by Mohanan (1982) that there is a correlation between a rule's making reference to word-internal structure, and its ability to have lexical exceptions. He proposes therefore that as a further feature distinguishing between lexical and post-lexical rule operations, only lexical rules may have exceptions.

1.7 Structure preservation

As a final important distinction between lexical and post-lexical rule operations, Kiparsky (1982) has shown that rules applying in the lexicon are subject to constraints on 'structure-preservation' that do not necessarily hold of post-lexical rules. For example, if a given language's syllabic inventory does not include

syllables with a branching rime, then a lexical rule of vowel deletion in such a language will not be able to create a branching rime. On the other hand, post-lexical application of rules may create a variety of syllables unattested in lexical representations.

1.8 Summary

Below is a summary of the properties discussed above, that distinguish between rules applying lexically and rules applying post-lexically:

(8)	<u>LEXICAL</u>	<u>POST-LEXICAL</u>
a.	may refer to word-internal structure	a. cannot refer to word-internal structure
b.	may not apply across words	b. may apply across words
c.	may be cyclic	c. cannot be cyclic
d.	if cyclic, then subject to strict cycle	d. non-cyclic, hence across-the-board
e.	structure-preserving	e. need not be structure-preserving
f.	may have lexical exceptions	f. cannot have lexical exceptions
g.	must precede all post-lexical rule applications	g. must follow all lexical rule applications

1.9 Phonetic rules

A last point, before leaving this brief outline of lexical phonology, concerns the role of 'phonetic' rules in the above model.

There is increasing evidence that rules of a strictly phonetic nature are nevertheless language-particular rules (Pierrehumbert 1980, Liberman and Pierrehumbert 1982). For example, if we compare the use of aspiration in different languages, we observe systematic differences between such languages as to the degree of phonetic aspiration present. Liberman and Pierrehumbert (1982) have suggested that an adequate model of grammar must contain a phonetic component. Such a phonetic component will contain language-specific rules that interpret the output of the phonology. They point out that many 'allophonic' rules may actually belong in such a phonetic component instead of in the phonological component where they are generally located. Liberman (1983) suggested, for example, that aspiration in English can profitably be looked on as a phonetic -- and not as a phonological -- rule.

Liberman (1983) even raises the possibility that such a phonetic component is in fact the post-lexical component as discussed above. Hence the phonology of a language would consist of a lexical 'phonological' component and a post-lexical 'phonetic' component. Evidence will be presented in this thesis suggesting that the 'post-lexical = phonetic' position is too strong. Nevertheless, the basic move of positing a phonetic component will be adopted, and incorporated into the grammar along the following lines:

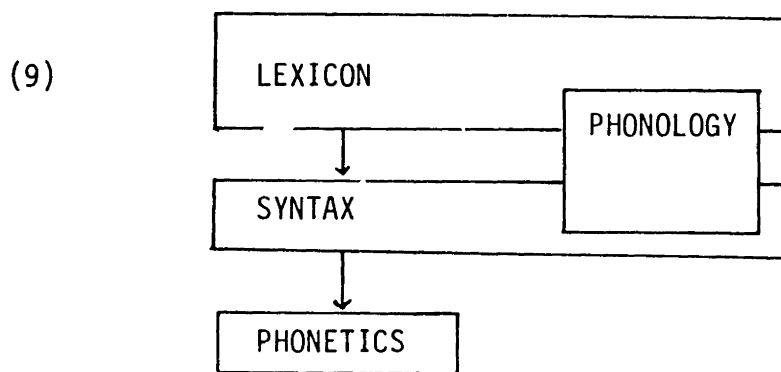

This model encodes the 'interpretive' function of the phonetic component by having its input be the final output of the post-lexical phonology.

While further research is required before we can clearly determine the properties that distinguish between the phonetic and phonological components, Liberman notes the following:

- 1) Phonological rules are restricted to binary use of features; phonetic rules involve gradient use of features.
- 2) The number of phonological entities is bounded; the number of phonetic entities is in principle unbounded.
- 3) The consequences of phonetic rules often involve matters of temporal structure and coordination.
- 4) Phonetic rules cannot have lexically-conditioned exceptions.
- 5) Liberman and Pierrehumbert propose, in addition, an 'accessibility' constraint on phonetic rules that will be discussed (and adopted) in chapter 2.

To summarize, I assume a model of lexical phonology that distinguishes between three levels of phonological representation: underlying, lexical and post-lexical. Formal and psychological

properties of the underlying and lexical levels have been discussed in work such as that of Mohanan (1982) and Kiparsky (1982). Formal properties of the third level, the post-lexical level, will receive some preliminary investigation in sections of this thesis; its psychological importance is left for further research.

2. Tiered phonology

Since Goldsmith's (1976) thesis on autosegmental phonology, there has been a wide range of research on a variety of phonological problems, all assuming some variety of tiered phonology. In this section, I will not review the autosegmental literature or attempt to motivate an autosegmental framework. I will, however, lay out certain issues that will be addressed in this thesis, and make clear certain assumptions about how a multi-tiered phonology is organized.

2.1 Association Conventions

The most basic -- and uncontroversial -- aspect of autosegmental phonology is that the phonological representation is broken up into a finite number of parallel tiers. Even though such tiers exhibit considerable independence -- for example, deletion on one tier does not entail deletion on another tier -- one can nevertheless only obtain a well-formed phonological representation once the various tiers are connected up. Hence a central issue in autosegmental theory concerns the principles ('association conventions') used for linking tiers in non-rule-governed situations.

One of the earliest proposals for relating tiers ⁶ was the Tone Mapping Rule of Williams (1971). Williams proposed a left-to-right mapping rule which linked tones to syllables. He assumed that if the mapping procedure ran out of tones before all syllables became linked to one, then the last remaining tone would automatically be spread to any remaining syllables in the relevant domain. On the other hand, if the procedure ran out of syllables before all tones had been assigned, Williams assumed that multiple linkings of tones to a single syllable could only result from a language-specific rule. Williams' position is outlined below:

- (10) a. It maps from left to right a sequence of tones onto a sequence of syllables.
- b. It assigns one tone per syllable, until it runs out of tones,
- c. then, it assigns the last tone that was specified to the remaining untoned syllables on the right, ...
- d. until it encounters the next syllable to the right belonging to a morpheme with specified tone.
- e. If the procedure above runs out of syllables, more than one tone may be assigned to the last vowel only if the grammar of the language includes a stipulation to that effect. ⁷

A rather different approach than that outlined above was proposed in Goldsmith (1976) where it was suggested that all stages

of a derivation were subject to the following Well-formedness Condition:

- (11) a. All vowels are associated with at least one tone.
 b. All tones are associated with at least one vowel.
 c. Association lines do not cross.

If a configuration violated the Well-formedness Condition, then association lines would be deleted or added until the representation was well-formed.

One crucial difference between the proposals of Williams and Goldsmith concerned contour tones: Goldsmith (1976) would automatically link more than one tone to a single tone-bearing unit, while Williams (1971) would not. Both approaches assumed automatic spreading of tones onto toneless vowels.

Looking basically at Kikuyu, Clements and Ford (1979) proposed a somewhat different set of association conventions, and argued for a position similar in many respects to that of Williams (1971). They still assumed automatic spreading of a single tone onto more than one vowel, but they returned to Williams' position that contour tones are only created by language-specific rules.

Halle and Vergnaud (1982), in yet a further development, proposed that the association conventions apply only to free ('floating') tones. Hence a configuration such as (12) will trigger the association conventions while (13) will not.

$$(12) \quad \begin{bmatrix} V & V & V \\ H \end{bmatrix} \rightarrow \begin{bmatrix} Y & V & V \\ H \end{bmatrix}$$

$$(13) \quad \begin{bmatrix} V & V & V \\ H \end{bmatrix}$$

In this thesis, I will argue that both the Tone Mapping Rule of Williams (1971) and the Well-formedness Condition of Goldsmith (1976) are too strong. Following Williams (1971), Clements and Ford (1979) and Halle and Vergnaud (1982), I will assume that multiple linkings of tones to a single tone-bearing unit come about only by language-specific rules. In addition, I will argue that multiple linkings of a single tone to more than one tone-bearing unit occur only as the result of language-specific rules as well.

I propose, therefore, that the universal aspects of the Well-formedness Condition and the Tone Mapping Rules are as follows:

(14) Association Conventions:

- Map a sequence of tones onto a sequence of tone-bearing units, a) from left to right
- b) in a one-to-one relation.

(15) Well-formedness Condition:

Association lines do not cross.

Note that the proposal given in (14) automatically derives Halle and Vergnaud's (1982) proposal that the association conventions apply only to floating tones. Since tones are linked to tone-bearing units only in a strict one-to-one relation, a linked tone can never be subject to further linking by convention.

Detailed arguments for the strictly one-to-one association conventions proposed in this thesis will be given in a number of sections for a variety of languages; this set of conventions will, however, be assumed throughout the text, even where no specific arguments are presented for the revised position.

2.2 When do the conventions apply?

Another issue that relates to the association conventions is not how they apply, but when they apply. The basic approach that has been adopted with respect to this issue since Goldsmith (1976) is that the conventions apply whenever possible throughout the derivation. This means that rules of vowel or tone epenthesis, vowel or tone deletion, etc. will automatically be followed by reapplication of the association conventions. One alternative approach would be to assume that the association conventions apply only at the beginning of a derivation, but not automatically elsewhere.⁸ Hence linkings even of floating tones to free tone-bearing units would be solely by stipulation if the relevant configuration has been derived by rule. For example, given a derivation such as in

(16), where a rule of vowel-deletion deletes \underline{v}_1 , a theory where the association conventions apply automatically would derive (17), while a theory where the conventions apply only at the beginning of the derivation would leave the output of (16) unaffected (unless by later rule).

$$(16) \quad \begin{bmatrix} v_1 & v_2 \\ | & \\ H & \end{bmatrix} \rightarrow \begin{bmatrix} \phi & v_2 \\ | & \\ H & \end{bmatrix}$$

$$(17) \quad \begin{bmatrix} \phi & v_2 \\ \text{---} & \\ H & \end{bmatrix}$$

Since the two approaches would have quite different results in a number of cases, the choice between such alternatives will depend on empirical considerations. Evidence will be discussed in this thesis that supports the more established view that the re-application of the Association Conventions is automatic. One class of counter-examples will be discussed, however, where automatic re-application of the Association Conventions appears to be blocked. The class of cases being referred to involves rules that specifically de-link tones and it will be proposed in chapter 3 that precisely in such cases, re-linking is not automatic.⁹

Another issue related to when the Association Conventions apply, concerns the class of 'Initial Tone Association Rules' discussed in work such as that of Clements and Ford (1979) and

Laughren (1983). They propose that prior to the initial application of the Association Conventions, certain language-specific rules may apply to link free tones in a manner other than the conventional left-to-right linking. Although I will not discuss such rules at any length in this thesis, some supporting evidence for such a class of rules will be presented in the discussion of Yoruba in section 3.3 of chapter 3.

Note that by developing a theory where spreading of autosegments is not automatic, we allow configurations to arise in which certain tone-bearing units remain toneless even after the Association Conventions and/or tonal rules have applied. An example would be the configuration seen in (13) above. In fact, the same issue of how to deal with toneless vowels arises even in a theory that posits automatic spreading of tones: what happens to vowels if there is no tone available for association?

$$(18) \quad \left[\begin{array}{c} V \quad V \quad V \\ \end{array} \right]$$

2.3 Linking of tiers

Before discussing possible answers to this question, I will turn briefly to certain additional issues relating to a multi-tiered representation.

If tone were the only feature that was 'autosegmentalized', there would be in effect two tiers -- the tone tier and the 'phonemic'

tier. But such is not the case. Nasality may be represented on a separate tier, vowel harmony features may be autosegmentalized, etc. This means that a language may require several independent (but parallel) tiers in its phonological representation. The question therefore arises as to which tiers any given tier can be linked to. That is, are there limitations on the relating of tiers? Could a tone tier, for example, link directly to a nasality tier? Or could a tone tier link directly to a vowel harmony tier?

Consider the following problems:

I. If three tiers are related as in (19), there is no way of non-arbitrarily determining how timing relations should be executed in such a case. How many 'segments' are we dealing with? two (tier p)? three (tier m)? four (tier n)? If all tiers are of equal status, then there is no way of telling.

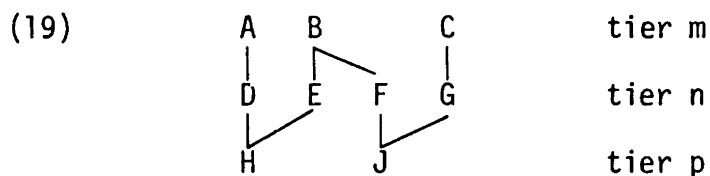

II. Look at (20) below:

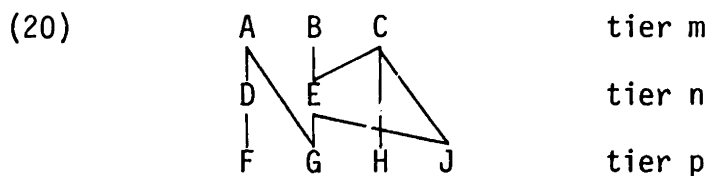

Such a case would seem to constitute a violation of the constraint

prohibiting crossed association lines (15). But if the tiers m, n and p are not on a single plane, then no association lines cross:

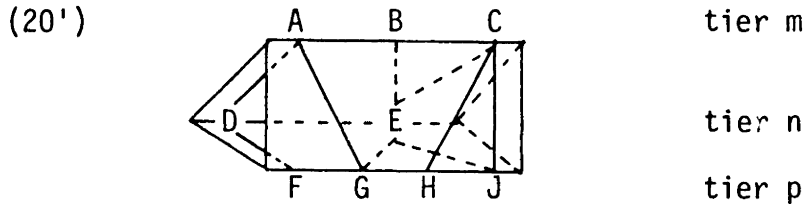

If such representations are well-formed, then one would need information as to the geometrical location of tiers on planes before being able to determine whether association lines cross.

III. Moreover, if we allow cases such as (20), then we end up with representations such as in (21).

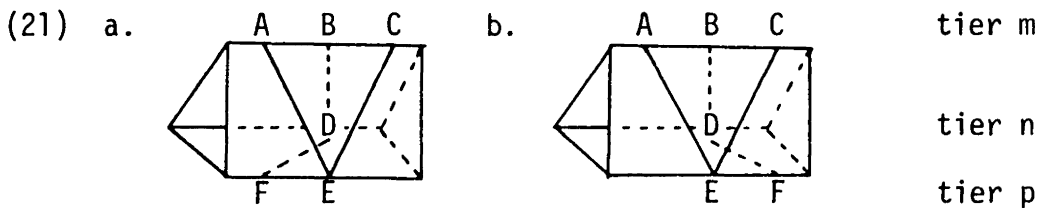

In (21), 'segments' A and C have the value E on tier p; segment B, on the other hand, has the value F by virtue of the transitive linking B - D - F. But note that F precedes E in (21a), while it follows E in (21b)! In other words, the representation in (21) has as a consequence that the temporally ordered sequence E F is non-distinct from the sequence F E.

With a bit of ingenuity, one can devise ever more unfortunate configurations -- all resulting from an unconstrained theory of multi-tiered phonology.

Problem I dissolves by recognizing the existence of a CV-skeleton that has a different status from autosegmental tiers (McCarthy 1979, Halle and Vergnaud 1982). In a representation such as (19), the CV-skeleton would determine timing relations. Hence if tier m is the skeleton, then (19) represents a three-segment sequence.

However, even if we have a skeletal tier in (20) and (21) -- which for purposes of discussion, I will assume to be tier m -- the problems raised as II and III still hold. They hold because in each case, we are allowing autosegmental tiers -- as distinct from the skeletal tier -- to link to each other. Hence in (20), tier n links to tier p, and in (21), similar inter-tier linkings occur.

A simple solution to the problems in II and III is to assume that part of the special nature of the skeletal tier is the following:

- (22) Autosegmental tiers can only link to slots in the skeletal tier.

The effect of the constraint in (22) is a considerably more restrictive multi-tiered theory. For example, it would rule out all of (19), (20) and (21) (with the exception of (19) if tier n was the skeletal tier).

A theory including (22) would allow tiers to radiate out from a central skeletal tier, more or less like the spokes of a wheel, as shown schematically in (23).

(23)

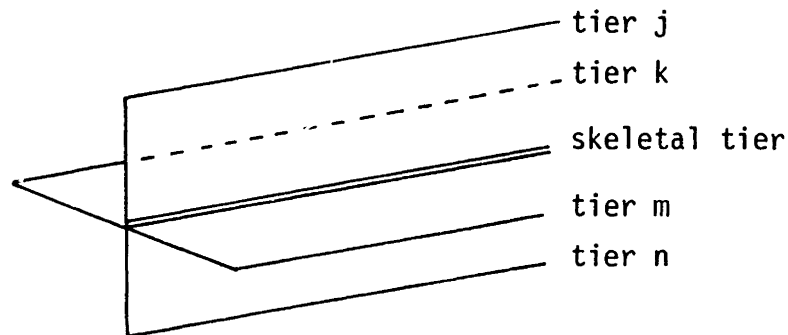

2.4 Default values and the 'phonemic core'

The final question that I wish to raise about such a representation concerns the existence of a 'phonemic core'. Is there a special 'phonemic' tier linked to the skeleton, whose properties are somewhat different than other autosegmental tiers? Can a feature be represented simultaneously in the 'phonemic core' and on an autosegmental tier? Does the phonemic core have an internal structure that is more than just an ordered set of feature matrices?

Concerning the issue of whether a tier can have internal structure, the reader is referred to Steriade (1982). The evidence of this thesis has no bearing on this issue. As for the representation of a feature on more than one tier -- for example, tone in the phonemic tier and on an autosegmental tier -- I will propose that such representations should be highly restricted.

The question of feature representations on more than one tier is particularly relevant for this thesis with respect to recent work involving redundant tone specifications. Halle and Vergnaud (1982) propose that a feature may be represented both autosegmentally

and in the phonemic core (ie. on a special phonemic tier). The autosegmental value takes precedence over the core value, so the core tonal value of \underline{V}_i will only surface if there is no tonal autosegment linked to \underline{V}_i . In Tonga, they assume that all vowels are redundantly specified as [+Low tone]. Hence a word with no tonal autosegment will surface with \underline{L} throughout.

- (24) a. \hat{i} - $\hat{b}\hat{u}$ - $\hat{s}\hat{u}$ ¹⁰ 'flour'
 [+L] [+L] [+L]
- b. \hat{i} - $\hat{b}\hat{a}$ - $\hat{s}\hat{a}\hat{n}\hat{k}\hat{w}\hat{a}$ 'men'
 [+L] [+L] [+L][+L]

A word that has certain vowels linked to tonal autosegments will surface with the core value on any unlinked vowels.

- (25) a. \hat{i} - $\hat{c}\hat{i}$ - $\hat{t}\hat{o}$ $\hat{n}\hat{g}\hat{a}$ 'the Tonga language'
 [+L] [+L] [+L][+L]
 H L
- b. $\hat{b}\hat{a}$ - $\hat{s}\hat{i}$ $\hat{l}\hat{u}$ $\hat{w}\hat{e}$ 'leopards'
 [+L] [+L][+L][+L]
 H L

An alternative approach, and the one that will be argued for in this thesis, is to assume that redundant tonal specifications are simply tonal autosegments supplied when a skeletal slot has not received any specification for tone. That is, no special status would be assigned to a 'phonemic' core; all tonal specifications in

such an approach would be on a single tier.

In Kiparsky (1982), it is proposed that lexical entries are underspecified and that unspecified values for features are filled in by rules that may be supplied either by universal grammar or by the grammar of the language in question. (Note also SPE.) Kiparsky proposes that all features are supplied minimally with a rule of the form $[] \rightarrow [\alpha F]$ (where α is either + or -), and that the set of such rules comprises a part of a theory of universal markedness.

Note however that the form of such default rules is appropriate for a theory where segments are represented as series of feature matrices, as in SPE. If a given matrix has no value for feature F , the the rule $[] \rightarrow [\alpha F]$ supplies the unmarked value. If, however, segments are represented as skeletal slots and features are specified by linking the skeletal slot to a sets of features on autosegmental tiers, then default rules must be of the form

$$(26) \quad \textcircled{X} \rightarrow \begin{array}{c} X \\ | \\ \alpha F \end{array}$$

That is, skeletal slots not linked to a value for $[F]$ are supplied with the specification $[\alpha F]$. Crucially, such default specifications are 'skeleton-driven'. That is, it is only by scanning skeletal slots that we determine whether every slot -- ie. every segment -- is linked to a complete set of features. For example, all slots in (27a) are specified for tone, although not all slots in (27b) are so specified.

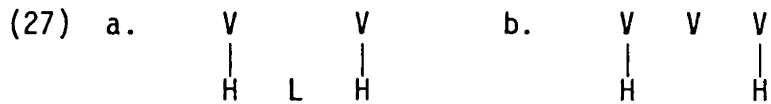

On the other hand, the fact there is an autosegment that is not linked to any skeletal slot in (27a) is irrelevant as far as determining whether the string in (27a) is completely specified for tone.

With respect to the Tonga examples, instead of a redundant core specification for tone, I assume a rule like the following:

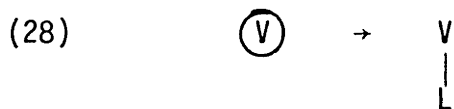

Under such an analysis, the examples in (24) and (25) above will be derived as follows:

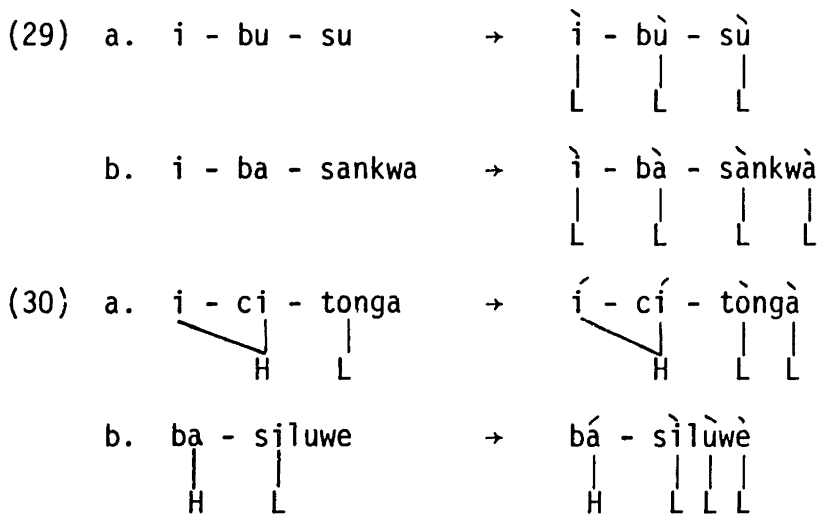

By assuming 1) that the skeleton is solely a sequence of slots, and 2) that the 'phonemic' tier has no special status with respect to

other tiers, we derive a theory where there is no formal difference in terms of tiers between 'segmental' features and 'autosegmental' features. 'Segmental' behaviour will basically result when each slot is linked to an autosegment prior to rule application:

$$(31) \quad \begin{array}{cccc} X & X & X & X \\ | & | & | & | \\ \left[\begin{array}{c} +F \\ -G \\ \vdots \end{array} \right] & \left[\begin{array}{c} +F \\ +G \\ \vdots \end{array} \right] & \left[\begin{array}{c} -F \\ -G \\ \vdots \end{array} \right] & \left[\begin{array}{c} +F \\ -G \\ \vdots \end{array} \right] \dots \end{array}$$

'Autosegmental' behaviour results when rules create multiple linkings or when linkings are incomplete prior to application of rules or conventions:

$$(32) \quad \begin{array}{cccc} X & X & X & X \\ \left[\begin{array}{c} +F \\ -G \\ \vdots \end{array} \right] & \left[\begin{array}{c} +F \\ +G \\ \vdots \end{array} \right] & \left[\begin{array}{c} -F \\ -G \\ \vdots \end{array} \right] & \left[\begin{array}{c} +F \\ -G \\ \vdots \end{array} \right] \dots \end{array}$$

I emphasize that the positing of default rules as in (26) and (28) is not an enrichment of the theory of underspecification and default rules proposed by Kiparsky (1982). It is an interpretation of Kiparsky's proposal within a theory with a CV-skeleton whose function is to coordinate the various tiers.

It will be shown in this thesis that in a number of languages, default tonal specifications must be autosegmental in nature, supporting the suggestions that such fill-in rules are of the form

given in (26). In the interest of a restrictive theory, it is therefore proposed that default tonal specifications must be autosegmental in general. To allow multiple possibilities for specifying redundant tonal values would create a needless enrichment of the theory. I propose the following constraint:

- (33) * [F] tier m
 |
 X skeletal tier
 |
 [F] tier n

This constraint rules out a representation where a skeletal slot is linked to the same feature on two different tiers. It rules out the supplying of redundant tonal features in the manner of Halle and Vergnaud (1982) since in a case like (25a), certain slots are simultaneously linked to a value of the feature [Low tone] on the phonemic tier and on the autosegmental tier.

Note that the constraint is formulated in terms of linkings and not as an absolute prohibition against the representation of a feature on more than one tier. This is because in certain languages like Arabic (McCarthy 1979), it is necessary to allow phonemic specifications on more than one tier. Note, however, that such cases do not violate the constraint in (33) since the specifications on one tier link to one class of skeletal slots, and the specifications on another tier link to a different class of skeletal slots.

The above position would be consistent with views of the

skeletal tier as either: 1) completely empty slots (X-slots), or 2) slots that are inherently [\pm syllabic] (CV-slots). While the first possibility pushes further the idea that the skeletal tier has no internal feature structure, the second possibility is logically possible and uses the feature [\pm syllabic] to define the otherwise unstructured nature of the skeleton. Work on interpreting the CV nature of the skeleton (that has been assumed in work such as that of McCarthy 1979, Halle and Vergnaud 1982, etc.) in terms of featureless X's has been emerging recently, for example in Kaye and Lowenstamm (1981) and Levin (1983). For expository reasons, I will assume a skeleton consisting of C's and V's in this thesis, but it should be kept in mind that if such labeling is derivative, this will not affect the issues discussed here.

2.5 Extratonicity

The final issue that I wish to raise concerning autosegmental representations concerns extrametricality. There has been work on stress systems recently (eg. Hayes 1980, 1982, Harris 1983) that has argued that certain constituents on the periphery of a stress domain should be excluded from consideration when applying stress rules, and such constituents have been labeled 'extrametrical'. In this thesis, I will argue that basically the same notion is applicable in tone systems. Tonal constituents that are marked as 'extratonic' lose their extratonicity if they cease to be on the periphery

of the relevant domain. That is, extratonal constituents are shown to be subject to the same Peripherality Condition proposed for extrametrical constituents by Harris.

2.6 Final remarks

In closing this section, I want to make it clear that the topics concerning tonal representations that I discuss in this thesis are merely a subset of important tonal issues. For example, there will be virtually no discussion of the relation between tone and syntax. There will be no investigation of the relation between tone and 'segmental' features such as vowel height, voicing, glottalization, etc. And there will be virtually no discussion of what constitutes a tone-bearing unit.

3. Tone and lexical phonology

In the above sections, we have seen that lexical phonology proposes an organization of the grammar where the phonology of a language interacts with its morphology and syntax in a particular set of ways; autosegmental phonology, on the other hand, proposes a particular type of organization for the phonological component itself. What then are the implications when autosegmental processes are examined within a lexical framework?

One can distinguish two ranges of implications. The first concerns the prediction that 'autosegmental' rules should manifest

properties comparable to 'segmental' rules with respect to lexical and post-lexical rule operations. Hence one would expect lexical autosegmental rules to exhibit the relevant LEXICAL properties listed in (8) above, while post-lexical rules would be expected to exhibit the relevant POST-LEXICAL properties. The second question concerns autosegmental constraints and conventions. Do they exhibit differences in their lexical and post-lexical behaviour?

3.1 Where are tones assigned?

Before getting into the question of how autosegmental rules and conventions work, one might consider the question of where autosegments are assigned. There are two basic possibilities: in the lexicon and post-lexically. With respect to tone, lexical vs. post-lexical assignment of tones may well correlate with what is commonly considered a tone vs. accent distinction. In a 'lexical tone' language like Yoruba, Tiv, etc., tones would be a part of the lexical entries; with 'stress' or 'pitch-accent' ¹¹ languages, such as English or Kijmatuumbi, tones would be assigned post-lexically to interpret accentual structures.

The principle of structure-preservation predicts that tone in its function of interpreting accentual structures could only be assigned post-lexically: if lexical entries do not include tone, but only accentual information, then rules of the lexicon cannot introduce tones without introducing new phonological categories. Hence if

lexical rules are structure-preserving, then the assignment of tones in such an accent language must be post-lexical. This predicts that tonal rules in such accentual languages must all be of the post-lexical variety. For example, they would not apply cyclically, they would not be morphologically conditioned -- but they could apply across word-boundaries. ¹²

In this dissertation, I will restrict my attention to languages which include tone as part of their underlying lexical entries. Accentual languages of the sort that use tone only to interpret metrical representations will not be discussed. ¹³

3.2 Cyclic tone association

Where tone is present in lexical entries, lexical theory makes a number of predictions. First, one would expect lexical tone association to depend on morphological bracketing, and one would expect to find cases where the association conventions apply cyclically. Cyclic tone association is predicted for the following reasons: 1) It has been hypothesized that the association conventions apply immediately whenever they can (Goldsmith 1976). 2) The output of word-formation processes is scanned by the phonology. 3) The Association Conventions are a part of 'universal phonology'.

The effect of these three assumptions is that the Association Conventions will apply after every morphological process. And this prediction is indeed borne out. It will be shown that in languages

like Margi (chapter 5) and Tiv (chapter 6), tone association does indeed respect morphological bracketing in precisely the way predicted by cyclic association and rule application. Moreover, it will be shown that cyclic tone association even plays a role in a language like Tonga -- traditionally viewed as 'accentual' (chapter 4).

But while the bulk of this thesis argues for cyclic association, I want to stress that such cyclic behaviour is the result of a cyclic morphology, and not a special property of tone per se. If tone was present in a language with a non-cyclic stratum, then tone association on such a stratum would be non-cyclic. Consider, for example, the case of Kikuyu. Clements and Ford (1979) propose that a morphological sequence such as (34a) will be associated as in (34b).

- (34) a. mo + e + rek + ang + er + i + ε
 L H L H
- b. mo + e + rek + ang + er + i + ε
 L H L H
-

Their proposal is one of non-cyclic association, and what is particularly interesting about such a case is that the tone of morpheme n often ends up linked to morpheme n+1. They propose that this shifting of tone to the right can be accounted for in the following way: 1) All morphemes (including their tones) are concatenated. 2) The first tone is linked to the second tone-bearing unit by an Initial Tone

Association Rule. 3) Normal left-to-right one-to-one linking takes place. 4) Tones spread onto left-over vowels. Within Clements and Ford's theory, the linking of the first tone is done by an Initial Tone Association Rule specific to Kikuyu, while the rest of the linkings are carried out by clauses of their version of the Well-formedness Condition.

This non-cyclic account of tone in Kikuyu would be possible within a lexical framework only if the stratum on which the various morphemes in (34) were added was non-cyclic. This would mean, therefore, that all lexical rules applying to such a sequence would also be non-cyclic. In this light consider the application of Dahl's Law in Kikuyu. Dahl's Law changes a k into ɣ 'when the next consonant sound is t, k, c or δ' (Armstrong 1940).¹⁴

Consider the following examples:

- (35) a. [ko [tɛ]] → ɣòtɛ̃ 'to throw away'
 b. [ko [oka]] → ɣoðká 'to come'
 c. [ko [ðaaka]] → ɣòðaàkà 'to play'

This rule must apply lexically for a number of reasons: 1) It applies stem internally as a 'morpheme structure constraint':

- (36) a. -ɣɛk- 'condemn'
 b. -ɣit- 'thatch a house'
 c. -ɣɔc- 'bend sharply'
 d. -ɣɛδ- 'beer flask'

2) It applies to prefixes, when the triggering consonant is in another prefix (39 below) or in the stem (35 above). 3) Suffixes neither trigger nor undergo the rule: 15, 16

- (37) a. [ñ [cɔk] eet] ε] → ñjɔkεεtε 'I had come back'
 b. [ko [hiŋ] ok] ek] a] → kohiŋokeka 'to be openable'

The above facts mean that the rule must be sensitive to word-internal morphological structure. It could not apply across-the-board in the manner of a post-lexical rule.

Supporting the rule's lexical status, one observes sporadic exceptions, such as with ideophones and loan words (Myers 1974):

- (38) a. kuku ~ γuku 'mocking interjection'
 b. mo + kekeñε 'Barbery (a plant)'
 c. kɔɔði 'course of study (English)'
 d. keki ~ γεki 'cake (English)'

Although by the criteria in (8), Dahl's Law must be lexical, Myers argues that it cannot be cyclic, on the basis of examples such as the following case discussed by Barlow (1951):

- (39) [ke [ke [ke [δok] a] → γεγεγεδoka 'and thus it was spoiled'

The multiple application of Dahl's Law in a case like (39) can be explained by non-cyclic rule application. In (39), the structural description of the rule is met by all three prefixal k's, and therefore all three k's undergo the rule.

non-cyclic analysis of tone.¹⁷ No stipulation would be required as to whether tone association was cyclic or non-cyclic -- the morphological stratum would be cyclic or non-cyclic, and all phonological rules operating lexically would then apply in the appropriate fashion. Hence one could not have a language like Kikuyu in that tone association was non-cyclic, but unlike Kikuyu in that other lexical rules would apply cyclically.¹⁸

3.3 Constraints on linkings

A second major question concerning autosegmental representations in lexical theory involves the issue of constraints on autosegmental linkings. It has been observed (CF: Halle and Vergnaud 1982) that languages differ as to the number of tones that can link to a single tone-bearing unit. It is proposed in this thesis that not only can different languages vary in this respect, but the same language can vary lexically and post-lexically. It will be shown that whereas multiple linkings of tones are ruled out completely in the lexical component of languages like Tiv, Dschang and Yoruba, in some cases post-lexical rules may extensively or restrictedly create contour tones.

3.4 Lexical vs. Post-lexical

Concerning autosegmental rule applications, it will be argued that the properties summarized in (8) above hold for the tonal rules examined. For example, cyclic rules apply before non-structure-

preserving rules; rules sensitive to morpheme structure apply cyclically, while rules oblivious to morpheme structure apply non-cyclically; etc. While there are many predictions of lexical phonology that have not been tested in this thesis, those that have been examined generally bear out the predictions.

3.5 Underspecification

As a last issue, I discuss the matter of underspecification of tonal entries with respect to the lexical model. It is suggested that default rules of tone assignment can occur lexically, post-lexically and phonetically. As the strongest hypothesis concerning such rules is that default tone-insertion rules are supplied by universal grammar, it will be suggested that the language-specific parameter concerning default insertion rules involves two aspects only: 1) a language may choose to implement the default values for one or both of the two tonal features supplied by universal grammar. 2) a language can select the component in which default tonal rules begin their application. These issues will be discussed in a number of places throughout the thesis, but the reader is referred especially to chapter 3 and to chapter 6, section 7. It is suggested that default rules cannot be extrinsically ordered with respect to phonological rules: where extrinsic orderings appear to exist, it is argued that such orderings can be derived by general principles.

This thesis shows that the lexical framework forces us to choose certain types of analyses that turn out to be preferred for empirical reasons. A number of ad hoc devices, such as tonal variables, accentual diacritics and morphological boundary symbols are shown to be unnecessary within this framework. By restricting the types of analyses available to a tonal grammar, we take a step towards a more explanatory theory of tone. And it is in this respect that the lexical framework offers a particularly interesting approach to tonal phonology.

4. Layout of chapters

Chapter 2 discusses the phenomenon of downstep and it is shown that downstepping requires the existence of a phonetic component. The rather complex case of downstep in Dschang-Bamileke is examined.

In Chapter 3, data from Yala Ikom and Yoruba is discussed with the aim of investigating the role of default rules in the lexical framework. Arguments for default tones are presented, some of the implications for tonal theory are considered, and some theoretical problems raised by underspecification are dealt with.

Chapter 4 looks at the notion of 'accent'. It is shown that the theory of tone presented in this thesis can account for the tonal properties of languages like Luganda and Tonga without recourse to accentual diacritics.





Problems of tonal polarity and morphologically conditioned tone lowering in Margi are examined in Chapter 5. It is shown that the relevant properties of Margi can be explained by incorporating into tonal theory the notion of 'extrametricality'

Finally, Chapter 6 tests the lexical framework by doing a case study of Tiv. Approaching Tiv within a lexical framework is shown to increase significantly our understanding of tonal processes in that language. The analysis is also shown to have a number of theoretical consequences.

5. Formal notation

Some of the important notational conventions assumed in this thesis are as follows:

V	:	linked slot
Ⓟ	:	free slot
V	:	ambiguously linked or free slot
T	:	linked tone
Ⓟ	:	floating ('free') tone
T	:	ambiguously linked or free tone

 : rightmost link
 : leftmost link
 : delink
 : link

FOOTNOTES: CHAPTER 1

1. This is not a new or recent observation. Pāṇini's grammar of Sanskrit recognized such a division. The difference between 'primary' and 'secondary' derivation was discussed in work such as Whitney (1879) and Bloomfield (1933).

2. This example is taken from Kiparsky (1982) where such cases are discussed in detail. The formulation of Trisyllabic Shortening given there is :

$$V \rightarrow [-\text{long}] / \text{--- } C_0 V_i C_0 V_j, \text{ where } V_i \text{ is not metrically strong.}$$

3. In Mohanan's work, an 'Opacity' condition is proposed instead of bracket erasure. The choice of conventions is not important for the purposes of this thesis.

4. Note that this ordering of rule applications is independent of the relative ordering of rules in a list. For example, if rule m is ordered prior to rule n in the list of phonological rules, but the domain of m is the post-lexical stratum and the domain of n is the lexical stratum, then application of n will precede application of m in a derivation.

5. But note Dresher (1983).

6. Technically, Williams did not speak of 'tiers' since he was working prior to the development of an explicit autosegmental framework.

7. Halle and Vergnaud (1982) make clause (10e) explicit.
8. The possible advantages of such an approach have been pointed out to me by Morris Halle with regards to Bamileke-Dschang and Akinbiyi Akinlabi with respect to Yoruba. Their arguments will be considered (although ultimately rejected) in sections of this thesis that discuss Dschang and Yoruba.
9. This possibility was pointed out to me by Paul Kiparsky.
10. Throughout this thesis, boundary symbols, dashes, etc. are employed as expository devices only -- they are held to have no theoretical status. Where morphological constituency is relevant to the process under discussion, bracketings will be employed.
11. It is suggested in this thesis that 'pitch-accent' languages fall into two categories: 1) those with lexical pre-linking of tones (see Chapter 4) and 2) those with post-lexical or phonetic assignment of tones.
12. It has been shown by Mohanan and Mohanan (1983) that there are problems with the strongest version of structure preservation, where it is assumed that any segment that is not present underlyingly cannot be introduced in the lexicon. It is conceivable therefore that a weaker version of structure preservation would allow a restricted class of cases where tones could be introduced into the lexicon even though they were not present underlyingly. This whole area requires detailed examination.
13. But see Pierrehumbert (1980), Pulleyblank (to appear) and Kiparsky (1982b, in preparation).

14. In the following discussion of Dahl's Law, I ignore questions about the precise formulation of the rule since it is not crucial to the point being discussed. Myers (1974), for example, suggests that $\underline{\delta}$ is underlyingly voiceless, allowing a simplification of the environment for the rule to 'voiceless segments'. Similarly, Myers suggests that the rule itself simply voices the velar stop and a general rule lenites velar stops.

15. These points are discussed in Myers (1970).

16. In the following Kikuyu cases, I leave open the question of whether prefixation precedes or follows suffixation since it does not crucially affect the point under discussion.

17. More detailed work on Dahl's Law and the relevant morphology is required before concluding positively that the morphological and phonological operations are non-cyclic. For example, in Armstrong (1940), one observes cases such as the following imperative form, where the alternating pattern $\underline{\gamma} - \underline{k} - \underline{\gamma}$ is exactly what one would expect with cyclic application of rules.

ndoyaakeeeyoteneera [---'---] 'Now don't on any account run.'

18. It is not clear whether more than one lexical stratum is required for Kikuyu. If not, then the non-cyclic stratum under discussion is of necessity the last lexical stratum. Further investigation will bear on the issue of whether non-cyclic lexical rules are restricted to the last lexical stratum. (See section 1.2 above.)

CHAPTER 2: DOWNSTEP

This chapter argues for a theoretical distinction between phonological and phonetic rules. A model for encoding this distinction is proposed and some of its implications are examined. The tonal phenomenon of downstep is discussed, and its particular relevance for the issue of phonological vs. phonetic rules is demonstrated.¹

The second half of the chapter is devoted to an analysis of the complicated system of tonal downstep in Dschang-Bamileke. It is shown that the distinction between phonological and phonetic rules is crucial for a proper understanding of the Dschang system.

1. The Phenomenon of Downstep

The phenomenon of downdrift/downstep is a paradigm example of an interpretive process that should take place in a phonetic component rather than in the phonology per se (see Liberman and Pierrehumbert 1982). The process of downdrift/downstep creates n-ary pitch contrasts out of a phonological representation using binary features -- there is in principle no limit to the number of pitch-levels that downstepping can create. Although I will often use the term 'downstep' to refer to both 'downdrift' and 'downstep', where it is necessary to make a distinction between the two terms this is what I assume it to be: 'downdrift' results when the tone that triggers a lowering of pitch is linked to a vowel and consequently is pronounced in the surface string; 'downstep' occurs when the tone that triggers pitch-lowering is not itself phonetically interpreted since it is unlinked to any vowel.

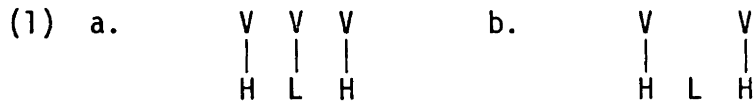

Hence the pattern in (1a) represents 'downdrift' while (1b) represents 'downstep'.

In a language such as Tiv, the lowering effect of the L-tones in (1a) and (1b) is the same. But in (1a) the L-tone receives a phonetic interpretation itself because it is linked to a core slot, while in (1b) the L-tone is not pronounced because it is not linked to such a slot. Given the independence of autosegmental tiers, a tone may either be: 1. linked 2. floating. It is proposed by Clements and Ford (1979) that there is no need for a special downstep entity in phonological theory -- downstep entities are simply floating tones. They are not pronounced because they are not linked to vowels. This proposal is interesting phonologically because it predicts that downstep entities will behave exactly like tones; that is, they will undergo and trigger tone rules. And phonetically, an unlinked tone will generally have the same pitch-lowering effect (if any) of a corresponding linked tone.

To illustrate the above points, consider the Igbo sentences below. In (2), the establishment of a new, and lower, 'ceiling' for following H-tones is triggered by a L-tone that surfaces in the phonetic string. In this particular example there are three successively lower pitch levels for H-tones. ²

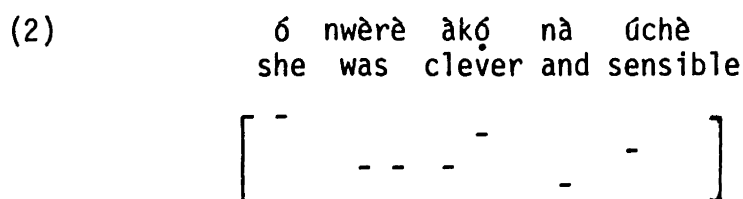

In (3), on the other hand -- a case where we happen to end up with four levels of H-tones -- H-tones are lowered twice without there being any surface L-tone to do the triggering (indicated in the transcription by an exclamation mark '!').

- (3) í!bú íbú !ébú sîlî íké
 carrying a load is difficult
- [- - - - - - - - -]

Since the phonetic downstepping of H-tones in (3) would be unpredictable if the phonological string contained nothing but H-tones, we must (following Clements and Ford) posit floating tones in the phonological string to account for the location of the phonetic downsteps. The existence of a phonetic downstep may be attributable to tense factors, syntactic factors, lexical factors, etc. In the present approach, such factors will condition the existence of a floating tone in the phonological representation. The downstep that ultimately occurs in the phonetic form is only the indirect result of such factors. Consider the following example from Tiv: ³

- (4) á !vá 'he came'
- [- -]

In this example, the verb stem va is lexically assigned a H-tone. The downstep is the result of being inflected for the General Past tense. If rules of phonetic interpretation could have access to tense information, then one might propose that the downstep in (4) is directly

assigned in the phonetic component. As such there would never need to be any phonological representation of such a downstep.

This is in contrast to an analysis where the General Past tense would trigger addition of a floating tone into the phonological representation of va. In the second analysis, the derived phonological representation would constitute the input to the phonetic component deriving the ultimate !H pattern.

As it turns out, there are reasons in Tiv for choosing the second alternative, where the General Past is indicated tonally in the phonology and the surface downstep is subsequently derived from the phonological representation. But this result is not sufficient. It would be undesirable for phonetic rules to have access to the type of tense information discussed above. For example, could a language contrast degrees of nasality on verbs as an indicator of tense? -- contrast degrees of aspiration on nouns to distinguish between nominative and accusative case? -- vary tonal amplitudes to distinguish agentive deverbal nouns from their verbal counterparts?

2. The Overall Model

A phonetic component in a restrictive theory would not interpret morphological or syntactic strings -- it would interpret phonological strings. The following model (discussed briefly in chapter 1) comes close to giving us this result.

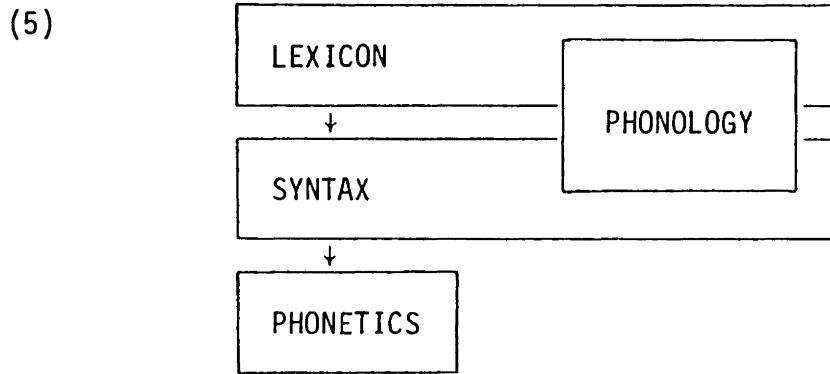

Given the model in (5), the input to the phonetic component is a phonological string that has undergone all relevant post-lexical rule operations. As represented in (5), however, there is nothing to prevent the phonetic component from having unlimited access to syntactic and perhaps some lexical properties of the phonological string. The desired result is obtained if we adopt some form of Accessibility Constraint, such as that proposed by Liberman and Pierrehumbert (1982), in addition to the model in (5).

(6) (Liberman and Pierrehumbert 1982: 54)

'... the computation of any parameter of object $Y[i]$ can only depend on the "accessible" properties of $Y[i]$ and $Y[i-1]$, where $Y[i-1]$ means the immediately previous object of the same type (if any). Thus, pitch accent can look back to previous pitch accent, phrase to previous phrase, etc. "Accessible" is taken to include a small set of intrinsic properties of the objects, and any relations between them; it is intended to exclude any properties of the constituents of these objects.'

If the intrinsic properties referred to above are restricted to distinctive feature values, temporal relations, etc., then reference

to syntactic and morphological features is ruled out in the phonetic component.⁴ I have dwelt on the above issue because the distinction between phonological and phonetic representations is not always made. The n-ary rules typical of the phonetic component must be constrained so as not to have access to morphological and syntactic properties of phrases. Similarly, phonological representations do not require access to details of phonetic interpretation. Both these claims are reflected in the model shown in (5). The proposal in Clements and Ford (1979) that downsteps be represented phonologically as floating tones only takes on its full importance if morphological and syntactic features cannot trigger downstepping directly in the phonetic representation without the intermediate stage of having a downstep entity present in the phonological string.

To sum up, downdrift/downstep clearly involves an n-ary process of the type assigned to the phonetic component of a grammar. Given the model in (5), as well as the Accessibility Constraint given in (6), all the information required to assign phonetic pitches to a phonological string must be present in that string. Adopting Clements and Ford's proposal about the nature of downstep entities, this means that morphologically and syntactically conditioned downsteps involve representations including floating tones.

3. Phonetic Variation

Comparable phonological sequences may be realized phonetically by different languages in quite distinct forms. For example, the configurations seen in (1) above (repeated below as 7) would be

and Ford (1979, 1981), there is no appreciable lowering of tones after a linked L-tone -- that is, there is no downdrift. But after a floating extra-low tone, both H and L tones are downstepped:

- (10) a. áhɛ̀ɪ̀rɛ́ moà̀yáhiɲá́ ! ɲjátá
 he-gave weakling star
 [- - - -]
 [- - -]
- b. áhɛ̀ɪ̀rɛ́ moánèkì ! ɲjátá
 he-gave Mwaniki star
 [- - -]
 [- - -]
- c. áhɛ̀ɪ̀rɛ́ moánèkì ! bìrìbìrì
 he-gave Mwaniki chillies
 [- - -]
 [- - - - - -]

Moreover, we see that the phonetic interval for downstep is different in Kikuyu than in Tiv and Igbo. In Kikuyu a downstepped H falls to the level of a preceding L, while in Tiv or Igbo a downstepped H is only slightly lower than a normal H.

Yet another pattern is observed in Nawdm, a Gur language of Togo described by Nicole (1980). Nicole shows that Nawdm, like Kikuyu, exhibits downstepping of both H and L tones.

- (11) a. fɛ́:gù ! jùlé mó:té
 sheep eats grass 'the sheep eats grass'
- b. ?à bá ñ ! fògá
 3sg be with wife 'he has a wife'
- c. ?à bá ñ ! má:rá
 3sg be with elder 'he has an elder brother'

In the above examples, (11a) illustrates a L!L sequence, (11b) illustrates H!L, and (11c) illustrates H!H. The examples in (11b) and (11c) are particularly interesting since they show that the downstep entity associated with the preposition ń! 'with' triggers downstepping of both H and L tones. As Nicole points out, this rules out the possibility of having different triggers for downstepping L and H tones since the downstep entity must be the same for both L and H tones.

I assume that in Nawdm, as in Kikuyu, the downstep trigger is a floating tone, and moreover that it is a floating L. Nicole himself refrains from making this assumption since, according to him, a floating L-tone could explain the lowering of a H-tone but not of a L-tone since L-tones in a sequence never drop. But we have already seen from the case of Dschang above (9) that in some languages linked tones must be distinguished from floating tones as far as their phonetic pitch lowering effect is concerned.

Moreover, there is an interesting form of support for the proposal that the downstep entity in Nawdm is a L-tone. In addition to patterns such as illustrated in (11), Nawdm exhibits downdrift:

- (12) ?à bá ?à bé: ?à tó 'she will be able to pound'
 3sg be 3sg can 3sg pound
 [- - - -]

That the lowering of H-tones is triggered by intervening L-tones is clear from examples such as (13) where there is no downdrift.

- (13) ?á má:rá há:rè 'his elder brother's house'
 3sg elder house
 [- - - -]

Hence the downstep system of Nawdm differs from that of Kikuyu in that Nawdm combines 'normal' downdrift with downstepping of both H and L tones; Kikuyu, on the other hand, downsteps H's and L's without exhibiting downdrift.

As two final examples, consider Kishambaa and Kĩmatuumbi. In Kishambaa, Odden (1983) observes that every H-tone is downdrifted. We therefore obtain phrases like the following:

- (14) a. ni ngoto du 'it is only a sheep'
 | | | |
 H H H H
 [- - - -]
- b. niwakome makui 'I killed the dogs'
 | | | | | |
 H L L L L HL
 [- - - - -]

In Kĩmatuumbi, H-tones on consecutive syllables are upstepped:

- (15) a. naatĩtuumbuká pandó yaángu 'I fell by my bucket'
 | | | | | | | |
 LL H LL L H L H LH L
 [- - - - -]

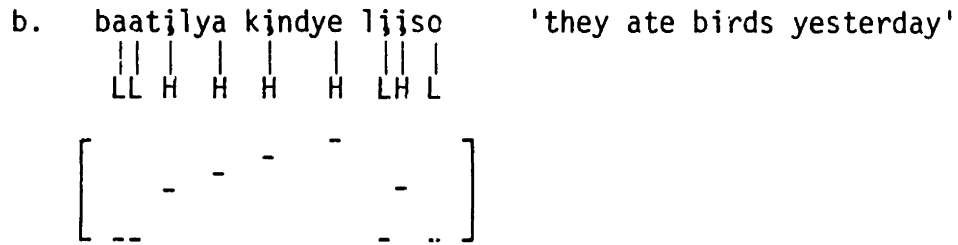

4. Phonetic models

It is not within the scope of this chapter to discuss all the types of ways that strings of tones can be phonetically interpreted. The reader is referred to Welmers (1973), Clements (1980), Huang (1980) and Odden (1983) for discussion of a number of attested possibilities. In this section, however, I will contrast briefly two types of proposals for encoding downdrift/downstep.

4.1 Constituency

Clements (1980), Huang (1980) and Odden (1983) propose theories where phonetic realization of tones involves the construction of tree structures erected over tones. As a simple illustration consider the following (from Clements 1980). First, sequences of H's and L's are grouped together into constituents: (In (16), Clements' h = H, l = L)

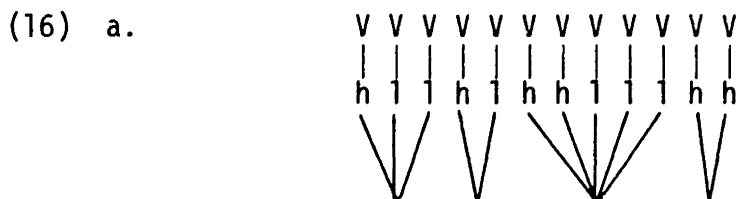

These constituents are then brought together into a right-dominant tree:

b.

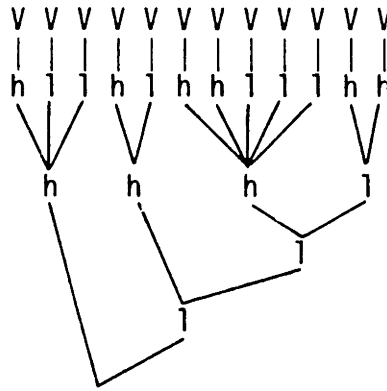

By interpreting the pitch of each successive foot as lower than the pitch of the preceding foot, the configuration in (16) would derive the pitch pattern in (17).

(17)

H			H			H H			H H
	L L		L			L L L			

Clements proposes the following set of rules to derive structures like those in (16).

(18) (= figure 13 in Clements 1980)

- a. Every tonal matrix containing l followed in the same row by h in the next column forms the right branch of a maximal n-ary branching tree.
- b. Any remaining tonal matrices are gathered into an n-ary branching tree.
- c. Sequences of trees constructed according to (a) and (b) are gathered into right-branching binary trees labelled by the labelling principle [h, l].

The structure in (16) would then be submitted to rules of pitch

interpretation. Such rules would differ for languages with 'partial' downstep such as Tiv and Igbo and for languages with 'total' downstep such as Kikuyu. That is, degree of phonetic lowering, etc. would be determined not by tree structure but by the phonetic rules that interpret such structure.

To summarize, this approach marks off sequences of tones into constituents. Such constituents are then grouped into larger constituents off of which phonetic pitch values will be interpreted by sets of language-specific rules.

4.2 Exponential decay

S.R. Anderson (1978), Liberman and Pierrehumbert (1982) and a number of earlier researchers propose a rather different approach for phonetically interpreting tonal strings. They suggest basically that phonetic interpretation of tones is a local process resulting from the scanning of tone sequences of a limited length. They have no notion of tonal constituent. The pattern in (17), for example, might be derived by rules such as the following:

- (19) a. T T - interpret the second T at the same level as
 the first tone
- b. H L - interpret L as one interval lower than H
- c. LH - interpret H as 3/4 as high as the immediately
 preceding H

With such a proposal, downdrift would result from interpreting the pitch of a H-tone after a L-tone as being a constant fraction of

the pitch of the previous H-tone. Hence sequences of the pattern LH will result in an exponentially decaying series.

For a detailed proposal along these lines, the reader is referred to the discussion of English in Liberman and Pierrehumbert (1982).

4.3 Exponential decay vs. trees

In this section I wish to briefly contrast the two approaches described above. It is not universally true that like tones are interpreted on the same pitch-level. Sequences of H-tones undergo downstepping in Kishambaa (14 above) while they undergo upstepping in Kijmatuumbi (15 above). In a theory without trees, such facts would be accounted for by appropriate modifications of the set of pitch interpretation rules. In a tree theory, such cases would be accounted for by adding to the rules of foot construction.

This would have a number of implications for tree theory. Presumably, the class of phonetic manipulations that includes downstepping and upstepping but excludes matters involving the degree of lowering or raising, etc. would have to be reflected in tree structure. If this were the case, then constraints on tree structure become constraints on the phonetic interpretation of tones.⁵ For example, Hayes (1980) argues that the only two possible types of metrical trees are binary trees and unbounded trees. While the well-known cases of downstep involve unbounded constituents, it appears to be the case that tones are grouped into binary constituents in Mahou, a language of the Ivory Coast (B. Moussa and J. Kaye personal communication). In Mahou, stretches of H-tones are realized phonetically as

High - Super High sequences. Given a theory that constrains phonetic interpretation by the use of trees, such cases are expected. One would not expect, however, to find a case where every third high tone was interpreted as a super high since such a pattern would require the construction of ternary feet -- ruled out in Hayes' metrical theory.

Creation of metrical feet also suggests a solution to a locality problem inherent in an approach relying solely on rules of the type given in (19). In order to assign a pitch value to \underline{H}_2 in (20), one must know the pitch value of \underline{H}_1 .

$$(20) \quad \begin{array}{ccc} V & V & V \\ | & | & | \\ H_1 & L & H_2 \end{array}$$

While a 'window' scanning three tones at a time could refer to both \underline{H}_1 and \underline{H}_2 in (20), it could not do so for (21).

$$(21) \quad \begin{array}{ccccc} V & V & V & V & V \\ | & | & | & | & | \\ H_1 & L & L & L & H_2 \end{array}$$

Nevertheless, \underline{H}_2 in (21) would typically be lowered in a manner completely analogous to \underline{H}_2 in (20). Moreover, there is in principle no limit to the number of L-tones that could intervene between the two relevant H-tones. So in terms of linear relations there is no finite number of tones that must be kept track of to allow a correct phonetic interpretation of two H-tones. But if tones are grouped into constituents, then the relevant relations are local. Assuming that (21) is organized into constituents as in (22), then one need merely define the pitch 'ceiling' for a given foot \underline{n} as a function of the

ceiling for the foot n-1.

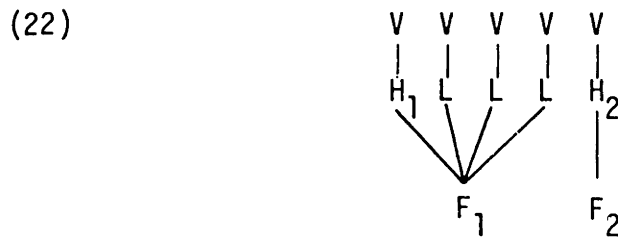

Note, moreover, that the Obligatory Contour Principle (Leben 1973) cannot be a principle of the phonetics.⁶ In cases such as Kishambaa and Kĩmatuumbi, sequences of like tones undergo downstepping and upstepping respectively. (See figures 14 and 15 above from Odden 1983) Hence one could not collapse sequences of like tones at the phonetic level as a mechanism for attaining the required locality conditions.

An additional issue that is relevant concerns the notion of pre-planning. Liberman and Pierrehumbert distinguish between 'hard' and 'soft' pre-planning. 'Hard' pre-planning refers to processing that is grammatically essential while 'soft' pre-planning refers to preparation that is optional and would result from performance factors of a number of sorts. For example, a speaker presented a cue-card with a sentence exhibiting seventeen levels of downdrift might well sigh deeply and begin her sentence in a falsetto. Such soft pre-planning need not be represented in the grammar of the language in question.

The issue of pre-planning is clearly an empirical one and further research is called for, especially in such areas as African downstep systems. Liberman and Pierrehumbert argue that the evidence that has been presented in favor of pre-planning can be accounted for with local models -- and clearly the assumption that there is no hard

pre-planning allows for a more restrictive theory of phonetics.

In this respect, it should be noted that the creation of tonal feet does not entail the grouping of such feet into larger constituents.⁷ The creation of tonal feet seems to imply only a minimal amount of pre-planning, if any at all. In fact, it was suggested above that tonal feet are required to keep downstep operations a local process. Grouping tonal feet into larger constituents, however, suggests hard pre-planning since it implies that the phonetic realization of a string of tones depends on a geometrical structure constructed over the entire string. Hence if Liberman and Pierrehumbert are correct that hard pre-planning is not attested, this is an argument for not grouping tonal feet into larger constituents.

To summarize, it is clear that an n-ary process such as downstep requires an implementational component with properties distinct from those of the strictly binary phonological component. It therefore becomes important to determine what the properties of such an implementational component are. While phonetic rules of the sort discussed in S.R. Anderson (1978) and Liberman and Pierrehumbert (1982) are clearly required, tree structures as proposed by Clements (1980) and Huang (1980) provide a method for constraining such rules. A number of questions are raised: Are all unbounded tonal feet left-dominant? Is it possible to construct constituents larger than the foot? -- While preliminary investigation suggests that the answer to both such questions is yes, further research in this area will be of considerable interest.

5. Dschang-Bamileke

In the remainder of this chapter I will discuss the case of downstep in the Dschang variety of Bamileke -- one of the Mbam-Nkam languages of Cameroon.

As mentioned in section 3., Dschang does not exhibit downdrift. So in a phrase such as (23), both H-tones are produced on the same pitch level.

$$(23) \quad \begin{array}{c} \left[\begin{array}{c} s\partial\eta \\ | \\ H \end{array} \right] \left[\begin{array}{c} e + s\partial\eta \\ | \\ L \quad | \\ H \end{array} \right] \quad \text{'bird of bird'} \\ \\ \left[\begin{array}{c} - \\ - \\ - \end{array} \right] \end{array}$$

Dschang does, however, exhibit downstep. Hence if the vowel of the associative prefix is deleted -- as normally happens in rapid speech --, then the result is that the second H is downstepped by the floating L that intervenes between the two H's.

$$(24) \quad \begin{array}{c} \left[\begin{array}{c} s\partial\eta \\ | \\ H \end{array} \right] \left[\begin{array}{c} s\partial\eta \\ | \\ L \quad | \\ H \end{array} \right] \quad \text{'bird of bird'} \\ \\ \left[\begin{array}{c} - \\ - \\ - \end{array} \right] \end{array}$$

While it is interesting that Dschang has downstep without exhibiting downdrift, it becomes even more interesting to try to account for the location of such downsteps. And not only does Dschang downstep H-tones, it also downsteps surface L-tones:

$$(25) \left[\begin{array}{c} n + dza \\ | \quad | \\ L \quad L \quad H \end{array} \right] \left[\begin{array}{c} e + n + dzwi \\ | \quad | \quad | \\ L \quad L \quad L \end{array} \right] \rightarrow \grave{n}dz\grave{a}^! \grave{a}\grave{n}dz\grave{w}\grave{i} \quad \text{'the axe of the thief'}^8$$

To provide an analysis for cases like (25) and to account for the location of downsteps in general is a central issue in Dschang tonology and will constitute a major part of the following discussion. It will be shown that the phonetic interpretation of downsteps follows in a straightforward manner from the derived phonological representation. The analysis is of interest because it requires a number of post-lexical phonological rules, as distinct from rules of phonetic interpretation. It therefore provides evidence for the distinction between post-lexical phonology and phonetics.

5.1 Background

Before dealing with the problem of how to represent downstep, I will present in this section certain relevant facts of the Dschang tonal system.

Monosyllabic and disyllabic nouns in Dschang exhibit the following surface tonal patterns in isolation:

(26) a.	<u>L+L</u>	$\grave{n}dz\grave{w}\grave{i}$ leopard	<u>L</u>	$n\grave{a}$ animal
b.	<u>L+L°</u>	$\grave{n}dz\grave{a}^\circ$ axe	<u>L°</u>	$k\grave{a}\eta^\circ$ squirrel
c.	<u>L+!H</u>	$\grave{m}^!bh\acute{u}$ dog	<u>!H</u>	$^!m\acute{o}$ ⁹ child
d.	<u>L+H</u>	$\grave{n}ts\acute{o}\eta$ thief	<u>H</u>	$s\acute{o}\eta$ bird

of the phonetic component. This predicts, correctly I believe, that final lowering cannot interact with any phonological rule of Dschang.

In addition, the falling tones created by final lowering in Dschang appear to be the only contour tones possible on a single mora. But as such contours are created only phonetically in the present analysis, one can formulate the following constraint on linkings: ¹⁰

(28) *

$$\begin{array}{c} \vee \\ \text{T} \quad \text{T} \end{array}$$

This constraint holds both lexically and post-lexically in Dschang, prohibiting linkings of more than one tone to a single tone-bearing unit. Following Halle and Vergnaud (1982), I assume that if a rule spreads a tone onto an already associated vowel, then the previous association line will automatically be deleted. We will see examples of this later on.

The !H pattern in (26c), m[!]bhú 'dog' for example, derives historically and synchronically from a HL sequence. To illustrate the proposed derivation, consider the following examples of singular imperative verb forms: ¹¹

(29) a. $\left[\left[\begin{array}{c} \text{t} \text{ɔ} \text{ŋ} \\ \vdots \\ \text{H} \end{array} \right] \text{ɔ} \right] \left[\begin{array}{c} \vdots \\ \text{H} \text{ L} \end{array} \right] \rightarrow \text{t} \text{ɔ} \text{ŋ} \text{ɔ} \quad \text{'call!'}$

b. $\left[\left[\begin{array}{c} \text{k} \text{ɔ} \text{ŋ} \\ \vdots \\ \text{L} \end{array} \right] \text{ɔ} \right] \left[\begin{array}{c} \vdots \\ \text{H} \text{ L} \end{array} \right] \rightarrow \text{k} \text{ɔ} \text{!} \text{ŋ} \text{ɔ} \quad \text{'like!'}$

Given the underlying forms in (29), the association conventions will correctly derive the surface HH sequence that we see in (29a).

On the other hand, the association conventions alone produce the following incorrect result for (29b):

$$(30) \quad \begin{array}{ccc} k\sigma\eta & + & \sigma \\ | & & | \\ L & & H L \end{array}$$

The way that I propose to obtain a downstepped H-tone in such a case is to perform an operation on the phonological string by the rule in (31).

$$(31) \text{ Metathesis: } \quad \begin{array}{ccc} L & H & \textcircled{L} \\ 1 & 2 & 3 \end{array} \rightarrow \begin{array}{ccc} & & \\ & & \\ 1 & 3 & 2 \end{array}$$

This rule -- which I will demonstrate below to apply post-lexically -- moves a floating L-tone to the left of an immediately preceding H-tone, provided that the H-tone itself is preceded by a L-tone. Note that the contextual L-tone is required to distinguish between cases (29a) and (29b). Metathesis will apply to (30) creating:

$$(32) \quad \begin{array}{ccc} k\sigma\eta & + & \sigma \\ | & & | \\ L & L & H \end{array}$$

Note that there is no clear way to derive the downstep in (29b) directly by means of phonetic interpretation. For example, if a H \textcircled{L} sequence were to be phonetically interpreted as !H, then we would predict *ḥ[!]ká s[!]ḥ 'the monkey of the bird' to be the result in a case such as the following:

$$(33) \quad \begin{bmatrix} \eta + ka \\ | \\ L \quad H \end{bmatrix} \begin{bmatrix} e + s\partial\eta \\ | \\ L \quad H \end{bmatrix} \rightarrow \begin{bmatrix} \eta + ka \\ | \\ L \quad H \end{bmatrix} \begin{bmatrix} \phi \quad s\partial\eta \\ | \\ L \quad H \end{bmatrix}$$

The actual result, however, is $\dot{\eta}k\acute{a} \quad \dot{s}\partial\eta$. Scanning left-to-right, the relevant input to the phonetic component is the same in (33) and (30). There would be no reason, therefore, to expect the phonetic component to distinguish between the two cases; there is, however, a phonological reason -- which will be discussed below -- for blocking Metathesis in (33) but not in (30). I conclude therefore that Metathesis is a rule of the phonology of Dschang.

Returning to nouns such as $\dot{m} \dot{b}h\acute{u}$ 'dog', Metathesis will apply if the stem $bh\acute{u}$ is synchronically assigned the HL melody from which it derives historically.

$$(34) \quad \text{Lexical:} \quad \begin{bmatrix} bh\acute{u} \\ | \\ H \quad L \end{bmatrix} \quad \text{Cycle 1: Association Conventions}$$

$$\begin{bmatrix} \dot{m} \\ | \\ L \end{bmatrix} \begin{bmatrix} bh\acute{u} \\ | \\ H \quad L \end{bmatrix} \quad \text{Cycle 2: Association Conventions}$$

$$\text{Post-lexical:} \quad \begin{bmatrix} \dot{m} + bh\acute{u} \\ | \\ L \quad L \quad H \end{bmatrix} \quad \text{Metathesis}$$

One problem with this approach is that the word $\dot{m}\acute{o}$ 'child' has a !H surface pattern even though it has no L-tone class prefix to trigger Metathesis. But as this is the only such lexical item in the language, I will simply assume that 'child' is lexically represented as follows:

(35) mɔ
 |
 L H

Tone association for this word is not by convention. Exceptionally, the second tone of its melody is lexically linked, thereby blocking association of the first tone. To summarize, Dschang nouns bear one of the following lexical tone melodies: L, LH, HL or H. One-to-one left-to-right association, in conjunction with the phonetic rule of Final Lowering and the phonological rule of Metathesis, go together to produce the correct surface forms for nouns in isolation.

5.2 Downstep in the Associative Construction

The question of how to represent downstep in Dschang becomes especially interesting when nouns are combined in the 'associative' (N_1 of N_2) construction. This construction consists of a head noun on the left with a genitive complement on the right. Both head nouns and genitive nouns consist of a noun stem and a class prefix, except certain class 1 nouns which consist of a noun stem alone. The genitive complement is formed by adding an 'associative' prefix to the [class prefix + noun stem] complex. The associative prefix is a form of agreement marker that agrees in class with the head noun. Tonally, it may be either H or L, while segmentally it is either e or a; the associative prefix generally deletes or else assimilates to a preceding segment in connected speech. ¹²

To illustrate the above morphology, I give below the underlying form ¹³ for ndzà ! àndzɔ̀ 'the axe of the thief'.

$$(36) \quad \begin{array}{c} \left[\begin{array}{c} \text{Class} \\ \text{Prefix} \end{array} \left[\begin{array}{c} \text{Noun} \\ \text{Stem} \end{array} \right] \right] \\ N_1 \end{array} \quad \begin{array}{c} \left[\begin{array}{c} \text{Assoc.} \\ \text{Prefix} \end{array} \left[\begin{array}{c} \text{Class} \\ \text{Prefix} \end{array} \left[\begin{array}{c} \text{Noun} \\ \text{Stem} \end{array} \right] \right] \right] \\ N_2 \end{array} \\ \\ \left[\begin{array}{c} n \\ L \end{array} \left[\begin{array}{c} \text{dza} \\ L \ H \end{array} \right] \right] \quad \left[\begin{array}{c} e \\ L \end{array} \left[\begin{array}{c} n \\ L \end{array} \left[\begin{array}{c} \text{dzwi} \\ L \end{array} \right] \right] \right] \end{array}$$

For reference during the following discussion, underlying and surface forms of associative phrases are illustrated in table 1 (taken from Hyman and Tadadjeu 1976). Bracketed numbers will be included with examples to refer the reader to the example number in table 1. Numbers 1 to 32 illustrate cases where N_2 has a class prefix; numbers 33 to 64 illustrate cases where N_2 has no class prefix. Examples 1 to 16 and 33 to 48 involve a L-tone associative prefix while the other examples involve a H-tone associative prefix. For the sake of 'compression', tones in underlying forms in table 1 will be indicated by diacritics; and following Hyman and Tadadjeu, divisions between class prefixes and stems will not be indicated. ¹⁴

5.2.1 Associative deletion

We have already seen strong evidence that a downstep entity before a H-tone should be analysed as a floating L-tone from an example illustrating the optional deletion of the vowel of the associative prefix:

$$(37) \quad \begin{array}{c} s\grave{a}\eta \quad e s\grave{a}\eta \quad \sim \quad s\grave{a}\eta \quad s\grave{a}\eta \\ \left| \quad \left| \quad \left| \quad \quad \left| \quad \left| \quad \left| \right. \right. \right. \\ \text{H} \quad \text{L} \quad \text{H} \quad \quad \text{H} \quad \text{L} \quad \text{H} \end{array} \quad \text{'bird of bird'}$$

$$\left[\begin{array}{c} - \\ - \end{array} \right] \quad \left[\begin{array}{c} - \\ - \end{array} \right]$$

TABLE 1

1.	/èfò	è + ñdzwì/	→	[èfò ñdzwì]	'chief of leopard'
2.	/èfò	è + ñkùò? /	→	[èfò ñkùò?°]	'chief of rooster'
3.	/èfò	è + mbhú /	→	[èfò m'bhú]	'chief of dog'
4.	/èfò	è + ñtsón/	→	[èfò ñtsón]	'chief of thief'
5.	/ñdzá	è + ñdzwì/	→	[ñdzá!à ñdzwì]	'axe of leopard'
6.	/ñdzá	è + ñkùò? /	→	[ñdzá!à ñkùò?°]	'axe of rooster'
7.	/ñdzá	è + mbhú /	→	[ñdzá!à m'bhú]	'axe of dog'
8.	/ñdzá	è + ñtsón/	→	[ñdzá!à ñtsón]	'axe of thief'
9.	/ñgyá	è + ñdzwì/	→	[ñ!gyá ñdzwì]	'house of leopard'
10.	/ñgyá	è + ñkùò? /	→	[ñ!gyá ñkùò?°]	'house of rooster'
11.	/ñgyá	è + mbhú /	→	[ñ!gyá m'bhú]	'house of dog'
12.	/ñgyá	è + ñtsón/	→	[ñ!gyá ñtsón]	'house of thief'
13.	/ñká	è + ñdzwì/	→	[ñká ñdzwì]	'monkey of leopard'
14.	/ñká	è + ñkùò? /	→	[ñká ñkùò?°]	'monkey of rooster'
15.	/ñká	è + mbhú /	→	[ñká m'bhú]	'monkey of dog'
16.	/ñká	è + ñtsón/	→	[ñká ñtsón]	'monkey of thief'
17.	/àpà	á + ñdzwì/	→	[àpà ñ!dzwì]	'bag of leopard'
18.	/àpà	á + ñkùò? /	→	[àpà ñ!kùò?°]	'bag of rooster'
19.	/àpà	á + mbhú /	→	[àpà!á mbhú]	'bag of dog'
20.	/àpà	á + ñtsón/	→	[àpà!á ñtsón]	'bag of thief'
21.	/làsòñ	é + ñdzwì/	→	[làsòñ ñ!dzwì]	'tooth of leopard'
22.	/làsòñ	é + ñkùò? /	→	[làsòñ ñ!kùò?°]	'tooth of rooster'
23.	/làsòñ	é + mbhú /	→	[làsòñ!ñ mbhú]	'tooth of dog'
24.	/làsòñ	é + ñtsón/	→	[làsòñ!ñ ñtsón]	'tooth of thief'
25.	/àpú	á + ñdzwì/	→	[à!pú ñdzwì]	'arm of leopard'
26.	/àpú	á + ñkùò? /	→	[à!pú ñkùò?°]	'arm of rooster'
27.	/àpú	á + mbhú /	→	[à!pú m'bhú]	'arm of dog'
28.	/àpú	á + ñtsón/	→	[à!pú ñ!tsón]	'arm of thief'
29.	/lâtón	é + ñdzwì/	→	[lâtón ñdzwì]	'feather of leopard'
30.	/lâtón	é + ñkùò? /	→	[lâtón ñkùò?°]	'feather of rooster'
31.	/lâtón	é + mbhú /	→	[lâtón m'bhú]	'feather of dog'
32.	/lâtón	é + ñtsón/	→	[lâtón ñ!tsón]	'feather of thief'

33.	/ɛfɔ̃	ɛ̃ + nā/	→	[ɛfɔ̃ nā]	'chief of animal'
34.	/ɛfɔ̃	ɛ̃ + kən̄ /	→	[ɛfɔ̃ kən̄°]	'chief of squirrel'
35.	/ɛfɔ̃	ɛ̃ + mɔ̃/	→	[ɛfɔ̃ mɔ̃]	'chief of child'
36.	/ɛfɔ̃	ɛ̃ + sən̄/	→	[ɛfɔ̃ sən̄]	'chief of bird'
37.	/ndzā	ɛ̃ + nā/	→	[ndzā nā]	'axe of animal'
38.	/ndzā	ɛ̃ + kən̄ /	→	[ndzā kən̄°]	'axe of squirrel'
39.	/ndzā	ɛ̃ + mɔ̃/	→	[ndzā a mɔ̃]	'axe of child'
40.	/ndzā	ɛ̃ + sən̄/	→	[ndzā a sən̄]	'axe of bird'
41.	/ŋgā	ɛ̃ + nā/	→	[ŋ gā nā]	'house of animal'
42.	/ŋgā	ɛ̃ + kən̄ /	→	[ŋ gā kən̄°]	'house of squirrel'
43.	/ŋgā	ɛ̃ + mɔ̃/	→	[ŋ gā mɔ̃]	'house of child'
44.	/ŋgā	ɛ̃ + sən̄/	→	[ŋ gā sən̄]	'house of bird'
45.	/ŋkā	ɛ̃ + nā/	→	[ŋkā nā]	'monkey of animal'
46.	/ŋkā	ɛ̃ + kən̄ /	→	[ŋkā kən̄°]	'monkey of squirrel'
47.	/ŋkā	ɛ̃ + mɔ̃/	→	[ŋkā mɔ̃]	'monkey of child'
48.	/ŋkā	ɛ̃ + sən̄/	→	[ŋkā sən̄]	'monkey of bird'
49.	/apā	á + nā/	→	[apā nā]	'bag of animal'
50.	/apā	á + kən̄ /	→	[apā kən̄°]	'bag of squirrel'
51.	/apā	á + mɔ̃/	→	[apā a mɔ̃]	'bag of child'
52.	/apā	á + sən̄/	→	[apā sən̄]	'bag of bird'
53.	/lāsɔ̃n̄	ɛ̃ + nā/	→	[lāsɔ̃n̄ nā]	'tooth of animal'
54.	/lāsɔ̃n̄	ɛ̃ + kən̄ /	→	[lāsɔ̃n̄ kən̄°]	'tooth of squirrel'
55.	/lāsɔ̃n̄	ɛ̃ + mɔ̃/	→	[lāsɔ̃n̄ n̄ mɔ̃]	'tooth of child'
56.	/lāsɔ̃n̄	ɛ̃ + sən̄/	→	[lāsɔ̃n̄ sən̄]	'tooth of bird'
57.	/apu	á + nā/	→	[a pu nā]	'arm of animal'
58.	/apu	á + kən̄ /	→	[a pu kən̄°]	'arm of squirrel'
59.	/apu	á + mɔ̃/	→	[a pu mɔ̃]	'arm of child'
60.	/apu	á + sən̄/	→	[a pu sən̄]	'arm of bird'
61.	/lātɔ̃n̄	ɛ̃ + nā/	→	[lātɔ̃n̄ nā]	'feather of animal'
62.	/lātɔ̃n̄	ɛ̃ + kən̄ /	→	[lātɔ̃n̄ kən̄°]	'feather of squirrel'
63.	/lātɔ̃n̄	ɛ̃ + mɔ̃/	→	[lātɔ̃n̄ mɔ̃]	'feather of child'
64.	/lātɔ̃n̄	ɛ̃ + sən̄/	→	[lātɔ̃n̄ sən̄]	'feather of bird'

Moreover, examples such as (32) and (34) show that a (L)H sequence results in a !H even when the preceding vowel is L. Note that the downstepped H after a L is in fact a downstepped High and not a Mid. Apart from evidence from alternations such as observed in (37), if such a !H is followed by a H, then the second H will be on the same pitch as the downstepped H -- not a higher one.

$$(38) \quad \begin{bmatrix} a & + & pu \\ | & & | \\ L & L & H \end{bmatrix} \begin{bmatrix} s\partial\eta \\ | \\ H \end{bmatrix} \rightarrow \text{a}^{\text{!}}\text{p}\acute{\text{u}} \text{ s}\acute{\partial}\eta \quad \text{'arm of bird'} \quad [60]$$

And if such a !H is followed by another !H, then we get a double downstep sequence.

$$(39) \quad \begin{bmatrix} a & + & pu \\ | & & | \\ L & L & H \end{bmatrix} \begin{bmatrix} m\text{ɔ} \\ | \\ L & H \end{bmatrix} \rightarrow \text{a}^{\text{!}}\text{p}\acute{\text{u}} \text{ !m}\text{ɔ} \quad \text{'arm of child'} \quad [59]$$

Both of the above facts are unexpected if such lowered tones are analysed as Mid-tones; both facts are expected if the lowered tones are downstepped High-tones.

5.2.2 H-spread (Dschang)

A second class of examples where the downstep trigger is a floating L before a H-tone can be observed as the result of a rule of H-tone spreading proposed by Hyman (1982).¹⁵

$$(40) \quad \text{H-spread (Dschang):} \quad \begin{array}{c} \text{V} \quad \text{V} \\ \diagdown \quad | \\ \text{H} \quad \text{L} \end{array}$$

This rule -- which like Metathesis applies post-lexically --

spreads a H-tone (either floating or linked) onto a following linked L-tone; the L-tone will automatically be de-linked since by constraint (28) Dschang does not allow more than one tone to be linked to a single tone-bearing unit. Consider the following example:

$$\begin{array}{l}
 (41) \quad \left[\begin{array}{c} 1\partial + t\text{ɔ}\eta \\ | \quad | \\ L \quad H \end{array} \right] \left[\begin{array}{c} e + n + ts\text{ɔ}\eta \\ | \quad | \quad | \\ H \quad L \quad H \end{array} \right] \quad [32] \\
 \\
 \left[\begin{array}{c} 1\partial + t\text{ɔ}\eta \\ | \quad | \\ L \quad H \end{array} \right] \left[\begin{array}{c} e + n + ts\text{ɔ}\eta \\ | \quad | \quad | \\ \text{H} \text{---} L \quad H \end{array} \right] \quad \text{H-spread (40)} \\
 \\
 \left[\begin{array}{c} 1\partial + t\text{ɔ}\eta \\ | \quad | \\ L \quad H \end{array} \right] \left[\begin{array}{c} n + ts\text{ɔ}\eta \\ | \quad | \\ \text{H} \text{---} L \quad H \end{array} \right] \quad \text{Assoc. V-deletion}^{16} \\
 \\
 \grave{1}\partial\acute{\text{t}}\text{ɔ}\eta \quad \acute{n}'\text{ts}\acute{\text{ɔ}}\eta \quad \text{'the feather of the thief'}
 \end{array}$$

The H of the associative prefix spreads onto the class prefix of $\acute{n}\text{ts}\acute{\text{ɔ}}\eta$, thereby delinking the L of the class prefix. The resulting $\textcircled{L}\text{H}$ sequence gives us a !H pattern on the surface.

In conclusion, we have seen that the $\textcircled{L}\text{H}$ configuration that results in a surface !H can result from: 1. deletion of the vowel of the associative prefix -- example (37). 2. Metathesis -- examples (32) and (34). 3. H-spread -- example (41).

5.3 Downstepped L-tones

I will now turn to representative examples of surface L!L sequences. First, consider the following:

$$(42) \quad \left[\begin{array}{c} \eta + \text{gya} \\ | \quad | \\ L \quad H \quad L \end{array} \right] \rightarrow \left[\begin{array}{c} \eta + \text{gya} \\ | \quad | \\ L \quad L \quad H \end{array} \right] \rightarrow \acute{n}'\text{gy}\acute{\text{a}} \quad \text{'house'}$$

$$(43) \quad \begin{array}{c} \left[\begin{array}{c} \eta + \text{gya} \\ | \quad | \\ \text{L} \quad \text{H L} \end{array} \right] \left[\begin{array}{c} \text{e} + \text{n} + \text{dzwi} \\ | \quad | \quad | \\ \text{L} \quad \text{L} \quad \text{L} \end{array} \right] \quad [9] \\ \\ \left[\begin{array}{c} \eta + \text{gya} \\ | \quad | \\ \text{L} \quad \text{L H} \end{array} \right] \left[\begin{array}{c} \text{e} + \text{n} + \text{dzwi} \\ | \quad | \quad | \\ \text{L} \quad \text{L} \quad \text{L} \end{array} \right] \quad \text{Metathesis (31)} \\ \\ \eta^! \text{gya} \quad \text{ndzwi} \quad \text{'the house of the leopard'}$$

After application of Metathesis and deletion of the associative vowel, one would expect that (43) would surface: * $\eta^! \text{gya} \text{ndzwi}$. In fact, however, the correct surface form is: $\eta^! \text{gya} \text{ndzwi}$. Clearly, none of the rules discussed so far will result in the lowering of the lexical H of $\eta^! \text{gya}$. I therefore propose a rule of assimilation as in (44).

$$(44) \quad \text{Lowering:} \quad \text{H} \rightarrow \text{L} \quad / \quad \text{L} \quad \underline{\quad} \quad \text{L}$$

Operating on the configuration in (43), this rule will produce:

$$(45) \quad \begin{array}{c} \left[\begin{array}{c} \eta + \text{gya} \\ | \quad | \\ \text{L} \quad \text{L L} \end{array} \right] \left[\begin{array}{c} \text{e} + \text{n} + \text{dzwi} \\ | \quad | \quad | \\ \text{L} \quad \text{L} \quad \text{L} \end{array} \right]$$

Note that since the structural description of Lowering is met in (43) by a tonal sequence that spans two words, Lowering must be a rule that applies post-lexically.

What is crucial about this example as far as the phonetic interpretation of downstep is concerned is that a floating L-tone must downstep both H and L tones. Hence in this respect Dschang resembles Kikuyu and Nawdm.

Before turning to a second type of case that results in a surface

L!L sequence, let us consider briefly the ordering of the three rules discussed so far. H-spread (40) must precede Metathesis (31): the structural description of Metathesis requires a floating tone and H-spread creates the required floating tone in cases such as (46).

$$\begin{array}{l}
 (46) \quad \left[\begin{array}{c} a + pa \\ | \quad | \\ L \quad L \end{array} \right] \left[\begin{array}{c} a + n + ts\grave{o}n \\ | \quad | \quad | \\ H \quad L \quad H \end{array} \right] \quad [20] \\
 \\
 \left[\begin{array}{c} a + pa \\ | \quad | \\ L \quad L \end{array} \right] \left[\begin{array}{c} a + n + ts\grave{o}n \\ | \quad | \quad | \\ H \quad L \quad H \end{array} \right] \quad \text{H-spread (40)} \\
 \\
 \left[\begin{array}{c} a + pa \\ | \quad | \\ L \quad L \end{array} \right] \left[\begin{array}{c} a + n + ts\grave{o}n \\ | \quad | \quad | \\ L \quad H \quad H \end{array} \right] \quad \text{Metathesis (31)} \\
 \\
 \grave{a}pa \quad !\grave{a} \quad n\acute{t}s\acute{o}n \quad \text{'the bag of the thief'}
 \end{array}$$

Moreover, the same example shows two additional facts: 1. Metathesis must apply post-lexically because its structural description is met in (46) over a word-boundary. 2. Metathesis must be ordered before Lowering (44) because the movement of the L in (46) correctly bleeds application of Lowering. Hence the correct order for the three rules is:

$$\begin{array}{l}
 (47) \quad \text{H-spread (40)} \\
 \quad \quad \text{Metathesis (31)} \\
 \quad \quad \text{Lowering (44)}
 \end{array}$$

With this in mind, let us turn to a second type of cases that results in a surface L!L sequence:

$$(48) \begin{bmatrix} n + dza \\ | \\ L \quad L \quad H \end{bmatrix} \begin{bmatrix} e + n + dzwi \\ | \\ L \quad L \quad L \end{bmatrix} \rightarrow \underset{\sim}{n} \underset{\sim}{d} \underset{\sim}{z} \underset{\sim}{a} \quad \underset{!}{\sim} \underset{\sim}{a} \quad \underset{\sim}{n} \underset{\sim}{d} \underset{\sim}{z} \underset{\sim}{w} \underset{\sim}{i} \quad \text{'axe of leopard'} \\ [5]$$

In such cases the surface downstep is in the same location as an underlying unlinked H. Hence on the face of it, such examples might seem to argue for allowing a floating H-tone to downstep a following L. But consider the effect of the rules discussed above on such a case:

$$(49) \begin{array}{l} \begin{bmatrix} n + dza \\ | \\ L \quad L \quad H \end{bmatrix} \begin{bmatrix} e + n + dzwi \\ | \\ L \quad L \quad L \end{bmatrix} \quad \text{H-spread (40)} \\ \begin{bmatrix} n + dza \\ | \\ L \quad L \quad H \end{bmatrix} \begin{bmatrix} e + n + dzwi \\ | \\ L \quad L \quad L \end{bmatrix} \quad \text{Metathesis (31)} \\ \begin{bmatrix} n + dza \\ | \\ L \quad L \quad L \end{bmatrix} \begin{bmatrix} e + n + dzwi \\ | \\ L \quad L \quad L \end{bmatrix} \quad \text{Lowering (44)} \end{array}$$

By applying the rules in the order given in (47) we correctly derive the surface form $\underset{\sim}{n} \underset{\sim}{d} \underset{\sim}{z} \underset{\sim}{a} \quad \underset{!}{\sim} \underset{\sim}{a} \quad \underset{\sim}{n} \underset{\sim}{d} \underset{\sim}{z} \underset{\sim}{w} \underset{\sim}{i}$ with no modification in the phonetic downstep rule. To maintain the hypothesis that a floating H triggers downstep, one would have to prevent these rules from applying to such cases in one way or the other.

5.4 L-deletion

In the preceding section it has been shown that a !L phonetic pattern results from a \textcircled{L} L phonological sequence. This position is not, however, trouble-free. Consider for example the contrast between (50) and (51).

(50)

$$\begin{array}{l} \left[\begin{array}{c} 1\grave{\alpha} + t\grave{\alpha}\eta \\ \underline{L} \quad \underline{H} \end{array} \right] \left[\begin{array}{c} e + n + dzwi \\ \underline{H} \quad \underline{L} \quad \underline{L} \end{array} \right] \quad [29] \\ \\ \left[\begin{array}{c} 1\grave{\alpha} + t\grave{\alpha}\eta \\ \underline{L} \quad \underline{H} \end{array} \right] \left[\begin{array}{c} e + n + dzwi \\ \underline{H} \quad \underline{L} \quad \underline{L} \end{array} \right] \quad \text{H-spread (40)} \\ \\ \left[\begin{array}{c} 1\grave{\alpha} + t\grave{\alpha}\eta \\ \underline{L} \quad \underline{H} \end{array} \right] \left[\begin{array}{c} n + dzwi \\ \underline{H} \quad \underline{L} \quad \underline{L} \end{array} \right] \quad \text{Associative V-deletion} \\ \\ \grave{1}\grave{\alpha}\acute{t}\grave{\alpha}\eta \acute{n}dzwi \quad \text{'the feather of the leopard'}$$

(51)

$$\begin{array}{l} \left[\begin{array}{c} 1\grave{\alpha} + t\grave{\alpha}\eta \\ \underline{L} \quad \underline{H} \end{array} \right] \left[\begin{array}{c} e + n + ts\grave{\alpha}\eta \\ \underline{H} \quad \underline{L} \quad \underline{H} \end{array} \right] \quad [32] \\ \\ \left[\begin{array}{c} 1\grave{\alpha} + t\grave{\alpha}\eta \\ \underline{L} \quad \underline{H} \end{array} \right] \left[\begin{array}{c} e + n + ts\grave{\alpha}\eta \\ \underline{H} \quad \underline{L} \quad \underline{H} \end{array} \right] \quad \text{H-spread (40)} \\ \\ \left[\begin{array}{c} 1\grave{\alpha} + t\grave{\alpha}\eta \\ \underline{L} \quad \underline{H} \end{array} \right] \left[\begin{array}{c} n + ts\grave{\alpha}\eta \\ \underline{H} \quad \underline{L} \quad \underline{H} \end{array} \right] \quad \text{Associative V-deletion} \\ \\ \grave{1}\grave{\alpha}\acute{t}\grave{\alpha}\eta \acute{n}'ts\grave{\alpha}\eta \quad \text{'the feather of the thief'}$$

The floating \underline{L} created by H-spread triggers downstepping when the following tone is \underline{H} (as in 51) but does not trigger downstep when the following tone is \underline{L} (as in 50). Hence we must distinguish two types of \textcircled{L} sequences, where one type triggers downstep and one type does not. This distinction can be captured by positing a rule that deletes floating L-tones before another L-tone:

(52) L-deletion: $\textcircled{L} \rightarrow \phi / \underline{\quad} \underline{L}$

This rule will correctly apply in examples like (50). It can be prevented from applying in cases such as (49) by ordering it before

Lowering. So in a \textcircled{L} HL sequence, L-deletion will be inapplicable; and subsequent lowering of the H to L will not feed L-deletion.

5.4.1 A Problem Case

Consider now the following problematic $\underline{L!L}$ sequence:

$$(53) \quad \begin{bmatrix} a + pa \\ | \\ L \quad L \end{bmatrix} \begin{bmatrix} a + n + dzwi \\ | \quad | \\ H \quad L \quad L \end{bmatrix} \rightarrow \hat{a} \hat{p} \hat{n} ! dzwi \quad \text{'bag of leopard'} \quad [17]$$

The rules discussed so far give us the following incorrect result in this case: $\hat{a} \hat{p} \hat{n} ! dzwi$. This is illustrated in the following derivation.

$$(54) \quad \begin{array}{l} \begin{bmatrix} a + pa \\ | \\ L \quad L \end{bmatrix} \begin{bmatrix} a + n + dzwi \\ | \quad | \\ H \quad L \quad L \end{bmatrix} \quad [17] \\ \\ \begin{bmatrix} a + pa \\ | \\ L \quad L \end{bmatrix} \begin{bmatrix} a + n + dzwi \\ | \quad | \\ H \quad L \quad L \end{bmatrix} \quad \text{H-spread (40)} \\ \\ \begin{bmatrix} a + pa \\ | \\ L \quad L \end{bmatrix} \begin{bmatrix} a + n + dzwi \\ | \quad | \\ L \quad H \quad L \end{bmatrix} \quad \text{Metathesis (31)} \\ \\ \begin{bmatrix} a + pa \\ | \\ L \quad L \end{bmatrix} \begin{bmatrix} a + n + dzwi \\ | \quad | \\ L \quad L \quad L \end{bmatrix} \quad \text{Lowering (44)} \\ \\ \begin{bmatrix} a + pa \\ | \\ L \quad L \end{bmatrix} \begin{bmatrix} n + dzwi \\ | \quad | \\ L \quad L \quad L \end{bmatrix} \quad \text{Associative V-deletion} \end{array}$$

If we review the derivation in (54), we note the following:

1. Since there is a downstep in the surface form of (53), it is likely that the required floating tone is derived by H-spread since no other

rule creates floating tones. 2. Metathesis presumably applies in the derivation of (53) since otherwise L-deletion (52) would delete the floating L-tone created by H-spread.

I propose therefore that the extra rule that such forms demand should apply after H-spread and Metathesis and be formulated as follows:

(55) L-spread:
$$\begin{array}{c} \text{V} \quad \text{V} \\ \text{---} \diagdown \quad | \\ \text{L} \quad \text{H} \quad \text{L} \end{array}$$

This rule is restricted to word-internal application, and applies iteratively from left to right. It requires that a L-tone be followed by a non-final linked H-tone. The H-tone is non-final in two senses: the vowel to which it is linked must not be final, and it must be followed by a L-tone. As formulated in (55), however, the second L may or may not be linked to the second vowel. Because of the one-to-one constraint (28), L-spread (like H-spread) will automatically trigger delinking of the H. L-spread will apply to the output of H-spread and Metathesis (that is, the third stage of the derivation in figure 54) as follows:

(56)
$$\begin{array}{l} \left[\begin{array}{c} \text{a} + \text{pa} \\ | \quad | \\ \text{L} \quad \text{L} \end{array} \right] \left[\begin{array}{c} \text{a} + \text{n} + \text{dzwi} \\ | \quad \diagup \quad | \\ \text{L} \quad \text{H} \quad \text{L} \end{array} \right] \\ \\ \left[\begin{array}{c} \text{a} + \text{pa} \\ | \quad | \\ \text{L} \quad \text{L} \end{array} \right] \left[\begin{array}{c} \text{a} + \text{n} + \text{dzwi} \\ \text{---} \diagdown \quad | \quad | \\ \text{L} \quad \text{H} \quad \text{L} \end{array} \right] \quad \text{L-spread} \\ \\ \left[\begin{array}{c} \text{a} + \text{pa} \\ | \quad | \\ \text{L} \quad \text{L} \end{array} \right] \left[\begin{array}{c} \text{a} + \text{n} + \text{dzwi} \\ | \quad \text{---} \diagdown \quad | \\ \text{L} \quad \text{L} \quad \text{L} \end{array} \right] \quad \text{L-spread} \end{array}$$

5.6 Post-lexical Application

Lowering was shown to apply post-lexically in examples (45) and (49); Metathesis was shown to apply post-lexically in example (46). Associative V-deletion must also apply post-lexically since its application depends on choice of speech styles -- it applies in rapid speech but not in careful speech.

- (59) a. Careful Speech: $\begin{bmatrix} s\partial\eta \\ | \\ H \end{bmatrix} \begin{bmatrix} e + s\partial\eta \\ | \\ L \quad | \\ H \end{bmatrix}$ 'bird of bird'
- b. Connected Speech: $\begin{bmatrix} s\partial\eta \\ | \\ H \end{bmatrix} \begin{bmatrix} s\partial\eta \\ | \\ L \quad | \\ H \end{bmatrix}$

But if we look closely at the rapid speech form we see that it should not in fact end up the way it does, given the formulation of Associative V-deletion in (58). Associative V-deletion should delete both vowel and tone of the associative prefix.

We require such a formulation for cases such as the following:

- (60) a. $\begin{bmatrix} a + pa \\ | \quad | \\ L \quad L \end{bmatrix} \begin{bmatrix} a + na \\ | \quad | \\ H \quad L \end{bmatrix} \rightarrow \grave{a}pa \grave{a}na$ 'bag of animal' [49]
- b. $\begin{bmatrix} e + f\partial \\ | \quad | \\ L \quad L \end{bmatrix} \begin{bmatrix} e + s\partial\eta \\ | \quad | \\ L \quad H \end{bmatrix} \rightarrow \grave{e}f\partial \acute{s}\partial\eta$ 'chief of bird' [36]

If Associative V-deletion deleted only the vowel of the associative prefix, then after application of Lowering we would expect (60a) to result in $\ast\grave{a}pa \acute{na}$. And in (60b), if only the vowel was deleted we would obtain $\ast\grave{e}f\partial \acute{s}\partial\eta$.

How then can we delete the tone of the associative prefixes in (60) but save it in (59)?

The answer lies in the application of H-spread. Consider (61).

$$(61) \begin{bmatrix} n + dza \\ | \\ L \quad L \quad H \end{bmatrix} \begin{bmatrix} e + s\partial\eta \\ | \\ L \quad H \end{bmatrix} \rightarrow \grave{n}d\grave{z}\grave{a} \acute{!} \acute{a} s\acute{\partial}\eta \quad \text{'axe of bird'} \quad [40]$$

In this example, the vowel of the associative prefix has not undergone Associative V-deletion; instead, it has assimilated to the preceding vowel. In order to get the vowel of the associative prefix to have a H-tone, H-spread must apply:

$$(62) \text{ a. } \begin{bmatrix} n + dza \\ | \\ L \quad L \quad H \end{bmatrix} \begin{bmatrix} e + s\partial\eta \\ | \\ L \quad H \end{bmatrix} \quad \text{H-spread (58)}$$

This application of H-spread will trigger Metathesis and we derive the desired result:

$$\text{b. } \begin{bmatrix} n + dza \\ | \\ L \quad L \quad L \quad H \end{bmatrix} \begin{bmatrix} e + s\partial\eta \\ | \\ L \quad H \end{bmatrix} \quad \text{Metathesis (58)}$$

This example shows that H-spread applies across word-boundaries, as does Metathesis. Both rules must therefore be applying post-lexically. We can now account for s^{acute}∂_η ^{acute}! s^{acute}∂_η. H-spread applies to derive (63b) from (63a).

$$(63) \text{ a. } \begin{bmatrix} s\partial\eta \\ | \\ H \end{bmatrix} \begin{bmatrix} e + s\partial\eta \\ | \\ L \quad H \end{bmatrix}$$

$$b. \quad \begin{array}{c} [s\partial\eta] \\ | \\ H \end{array} \begin{array}{c} [e + s\partial\eta] \\ | \\ L \quad H \end{array} \quad \text{H-spread}$$

Associative V-deletion will now apply subject to an interpretation convention for rules of the form $\begin{array}{c} X \\ | \\ F \end{array} \rightarrow \phi \dots$ proposed in Keyser and

Kiparsky (1982):

- (64) If the X and the F are "exhaustively linked to one another, then both elements are deleted. If however, either element is linked to some other element as well, then only that element which is not dually linked deletes."

If we assume this convention when applying Associative V-deletion then we correctly derive (65) from (63b):

$$(65) \quad \begin{array}{c} [s\partial\eta] \\ | \\ H \end{array} \begin{array}{c} [\phi \quad s\partial\eta] \\ | \\ L \quad H \end{array} \quad \text{Associative V-deletion}$$

So the floating tone in (65) is derived not by Associative V-deletion as suggested earlier in the discussion of Dschang; it is derived by a post-lexical application of H-spread.

Note that the form $\underline{s\acute{\partial}\eta} \ \acute{e}s\acute{\partial}\eta$ shows that H-spread is optional over word boundaries. Since both H-spread and Associative V-deletion are optional in their application -- depending on factors to do with speech style -- this analysis predicts forms such as $\underline{s\acute{\partial}\eta} \ \acute{e}'s\acute{\partial}\eta$ and $\underline{s\acute{\partial}\eta} \ s\acute{\partial}\eta$ if only H-spread or only Associative V-deletion applied. Hyman and Tadadjeu (1976) do not however mention such cases. If such forms are not attested then one might look to the effects of speech style on rule

application for an explanation of such gaps. In fact it is noteworthy in this respect that in almost all the cases in Hyman and Tadadjeu (1976), H-spread across word-boundaries and Associative V-deletion apply hand-in-hand.

5.7 Phrasal L-deletion

There is a specific class of cases involving the associative construction where Metathesis and Lowering are blocked from applying. Consider, for example, the phrase $\hat{n}k\acute{a} n\grave{a}$ 'the monkey of the animal'. Although we have seen above (figure 46) that H-spread must feed Metathesis, in example (66), such feeding must be blocked so as to prevent the form given in (67) from being created.

$$\begin{array}{l}
 (66) \quad \left[\begin{array}{c} \hat{n} + ka \\ \text{L} \quad \text{H} \end{array} \right] \left[\begin{array}{c} e + na \\ \text{L} \quad \text{L} \end{array} \right] \quad [45] \\
 \\
 \left[\begin{array}{c} \hat{n} + ka \\ \text{L} \quad \text{H} \end{array} \right] \left[\begin{array}{c} e + na \\ \text{L} \quad \text{L} \end{array} \right] \quad \text{H-spread (58)} \\
 \\
 (67) \quad \left[\begin{array}{c} \hat{n} + ka \\ \text{L} \quad \text{L} \quad \text{H} \end{array} \right] \left[\begin{array}{c} e + na \\ \quad \quad \text{L} \end{array} \right] \quad \text{Metathesis (58)} \\
 \\
 * \hat{n} \acute{k} \acute{a} n\grave{a}
 \end{array}$$

Before attempting an explanation of such cases, let us first take a look at the rule of Lowering. If, for the sake of discussion, we assume that Metathesis has been blocked in an example such as (66), we would now expect L-deletion (58) to give us the form in (68).

$$(68) \quad \begin{bmatrix} \eta + ka \\ | \\ L \end{bmatrix} \begin{bmatrix} | \\ H \\ | \end{bmatrix} \begin{bmatrix} e + na \\ | \\ \phi \\ | \\ L \end{bmatrix} \quad \text{L-deletion (58)}$$

We would now expect Lowering to apply, deriving the form in (69).

$$(69) \quad \begin{bmatrix} \eta + ka \\ | \\ L \end{bmatrix} \begin{bmatrix} | \\ L \\ | \end{bmatrix} \begin{bmatrix} e + na \\ | \\ L \end{bmatrix} \quad \text{Lowering (58)}$$

Hence after Associative V-deletion, we would incorrectly derive * $\underline{\eta}ka \underline{na}$.¹⁷ The problem, therefore, is to find a way to block both Metathesis and Lowering in cases such as (66). Essentially, what one needs to do is to remove the initial L-tone from consideration in such cases. And the obvious way of 'removing something from consideration' is a rule of deletion:¹⁸

$$(70) \quad \text{Phrasal L-deletion: } L \rightarrow \phi / \text{NP} [\text{---}]$$

This rule will delete the first \underline{L} of N_1 -- in the construction $\text{NP}[N_1 \text{ of } N_2]$ -- but will leave N_2 unaffected. It will correctly bleed application of Metathesis and Lowering in a case like (66) as the following derivation illustrates:

$$(71) \quad \begin{bmatrix} \eta + ka \\ | \\ L \end{bmatrix} \begin{bmatrix} | \\ H \\ | \end{bmatrix} \begin{bmatrix} e + na \\ | \\ L \\ | \\ L \end{bmatrix} \quad [45]$$

$$\begin{bmatrix} \eta + ka \\ | \\ L \end{bmatrix} \begin{bmatrix} | \\ H \\ | \end{bmatrix} \begin{bmatrix} e + na \\ | \\ L \\ | \\ L \end{bmatrix} \quad \text{H-spread (58)}$$

$$\begin{bmatrix} \eta + ka \\ | \\ \phi \\ | \\ L \end{bmatrix} \begin{bmatrix} | \\ H \\ | \end{bmatrix} \begin{bmatrix} e + na \\ | \\ L \\ | \\ L \end{bmatrix} \quad \text{Phrasal L-deletion (70)}$$

$$\begin{array}{l} \left[\begin{array}{c} \eta + ka \\ | \\ H \end{array} \right] \left[\begin{array}{c} \phi \quad \bar{na} \\ | \\ \phi \quad L \end{array} \right] \quad \begin{array}{l} \text{L-deletion \&} \\ \text{Associative V-deletion} \end{array} \end{array}$$

The prefix in such a case would then be assigned a L-tone by a default rule such as that discussed briefly for Tonga in chapter 1. ¹⁹

$$(72) \quad \textcircled{V} \rightarrow \begin{array}{c} V \\ | \\ L \end{array}$$

Hence the result of the derivation in (71), after default L-insertion, will be $\bar{\eta}k\acute{a} \bar{n}\grave{a}$.

As formulated in (70) however, Phrasal L-deletion is too general. With a noun like $\bar{m}^{\prime}bhu$ 'dog', or with an associative noun phrase with such a noun in head position, we do not want to block application of Metathesis:

$$(73) \quad \text{NP} \left[\left[\begin{array}{c} m + bh\bar{u} \\ | \\ L \end{array} \right] \left[\begin{array}{c} H \\ | \\ L \end{array} \right] \dots \right] \quad \text{Metathesis}$$

This can be accomplished by restricting the environment in which Phrasal L-deletion applies.

$$(74) \quad \text{Phrasal L-deletion (revised): } L \rightarrow \phi / \text{NP} \left[\begin{array}{c} [\text{---} H] \\ N \end{array} \right]$$

As revised in (74), the rule will not apply to a case like (73) but it will apply to a case like (71).

5.8 H-deletion

One final issue that must be discussed is a type of neutralization

that occurs when nouns of the L and LH classes are followed by a noun with a H-tone associative prefix.

- (75) a. $\begin{bmatrix} a + pa \\ | \\ L \quad L \end{bmatrix} \begin{bmatrix} a + n + dzwi \\ | \quad | \\ H \quad L \quad L \end{bmatrix} \rightarrow \grave{a}p\grave{a} \grave{n}!dzwi \quad \text{'bag of leopard'}$
[17]
- b. $\begin{bmatrix} \grave{1}\grave{\partial} + s\grave{o}\eta \\ | \quad | \\ L \quad L \quad H \end{bmatrix} \begin{bmatrix} e + n + dzwi \\ | \quad | \\ H \quad L \quad L \end{bmatrix} \rightarrow \grave{1}\grave{\partial}s\grave{o}\eta \grave{n}!dzwi \quad \text{'tooth of leopard'}$
[21]
- (76) a. $\begin{bmatrix} a + pa \\ | \\ L \quad L \end{bmatrix} \begin{bmatrix} a + n + ts\grave{o}\eta \\ | \quad | \\ H \quad L \quad H \end{bmatrix} \rightarrow \grave{a}p\grave{a} \acute{a} \acute{n}ts\acute{o}\eta \quad \text{'bag of thief'}$
[20]
- b. $\begin{bmatrix} \grave{1}\grave{\partial} + s\grave{o}\eta \\ | \quad | \\ L \quad L \quad H \end{bmatrix} \begin{bmatrix} e + n + ts\grave{o}\eta \\ | \quad | \\ H \quad L \quad H \end{bmatrix} \rightarrow \grave{1}\grave{\partial}s\grave{o}\eta \acute{n} \acute{n}ts\acute{o}\eta \quad \text{'tooth of thief'}$
[24]

H-spread (58) will apply within N_2 in all of the above cases, deriving (77a) for N_2 in examples (75a) and (75b), and deriving (77b) for N_2 in examples (76a) and (76b).

- (77) a. $\dots \begin{bmatrix} V + n + dzwi \\ | \quad | \\ H \quad L \quad L \end{bmatrix}$
- b. $\dots \begin{bmatrix} V + n + ts\grave{o}\eta \\ | \quad | \\ H \quad L \quad H \end{bmatrix}$

When we come to apply Metathesis, however, the structural description of the rule is met in (75a) and (76a) but not in (75b) and (76b). Nevertheless from the surface forms we can see that Metathesis has applied in all forms. The problem in the 'b' cases is that the floating H of the lexical LH pattern of N_1 prevents the

structural description of Metathesis (58) from being met.

A simple way of accounting for the neutralization that results in such cases is by a rule that deletes a floating H-tone whenever the H-tone in question is adjacent to another H-tone.

(78) H-deletion: $\textcircled{\text{H}} \rightarrow \phi / \text{H}$

If this rule is ordered before Metathesis and Lowering (see 58), then the derivations of the 'b' examples in (75) and (76) will proceed in the same way as the 'a' examples, yielding tonally comparable results.

While it may be the case that this rule must be stipulated for Dschang, it is also possible that it is a general convention. This possibility will be discussed in chapter 4 where it will be shown that the rule of H-deletion is important in explaining certain cases of tonal polarity.²⁰

5.9 A Residual Problem

While the analysis of Dschang presented here accounts for the bulk of the published data, there is nevertheless at least one unresolved question.

Hyman and Tadadjeu (1976) observe that there is a slow speech variant of $\text{[} \hat{\text{a}}\text{s} \hat{\text{o}}\eta \text{ s} \acute{\text{a}}\eta \text{]}$ 'the tooth of the bird' where the associative vowel surfaces with a L even though underlyingly it is H ($\text{[} \hat{\text{a}}\text{s} \hat{\text{o}}\eta \text{ } \grave{\text{e}} \text{ s} \acute{\text{a}}\eta \text{]}$). Although it is possible to formulate a rule that derives this particular form, Hyman and Tadadjeu have no explanation for why it is different. Subsequent researchers have also been unable to offer any explanation

as far as I am aware, and the present analysis is no exception.

5.10 Other Analyses

There have been a number of analyses of Dschang. The basic research on which subsequent work has been based is that of Hyman and Tadadjeu (1976). Other work includes preliminary research by Tadadjeu (1974) as well as a number of reanalyses of Hyman and Tadadjeu's work by S.C. Anderson (1980), Stewart (1982) and Hyman (1982).

The important distinction of phonological vs. phonetic rules was not made in any of the above references. Hence, for example, the rule of Final Lowering was treated as a phonological rule in the above works. This had particularly unfortunate results in the approach taken by S.C. Anderson where distinct feature representations were assigned for different phonetic pitches. Hence a downglided tone required a distinct feature representation. This approach becomes even more problematic when downstep is taken into account. Anderson specifies !H as M ([+high, +lowered]) and a !L as X ([-high, +lowered]). While it is possible to construct an analysis using such a system for phrases of extremely restricted length, such a phonological approach to downstep fails completely in longer phrases such as the following (Tadadjeu 1974):

- (79) a. sâŋ !sâŋ !sâŋ !sâŋ ... 'bird of bird of bird ...'
 b. kãŋŋ !kãŋŋ !kãŋŋ !kãŋŋ ... 'squirrel of squirrel of squirrel ...'

With such cases of recursion, it is in principle impossible to provide an account that will assign a distinct feature specification to every phonetic pitch level -- at least, if we assume that phonological features form a finite set.

Stewart's (1982) approach is not subject to the type of criticism just discussed for Anderson. In fact, in discussing Anderson's work Stewart notes that within an autosegmental account, it would be possible to analyse the downstep entity in Dschang as a floating L-tone -- precisely as has been done in this chapter. Stewart, however, does not adopt such an approach. Instead, he utilizes a phonological downstep ('key lowering') entity, where rules may insert, transpose, etc. such entities. By assuming such downstep entities, Stewart does not derive a theory devoid of floating tones (or their equivalent in his framework). Consequently, the positing of such downstep entities constitutes a powerful addition to tonal theory which is not required in the approach taken here. Stewart also requires a distinction between 'fluid' and 'solid' syllables. In part this simply encodes the floating tone/linked tone distinction since 'floating' tones are represented by Stewart as tones assigned to zero syllables. But while zero syllables are fluid, so are a number of other syllables, such as prefix syllables. No such distinction is required in the approach taken here.

Recent work by Hyman (1982) gives an analysis very similar in important respects to that given here. We assume basically the same underlying forms, I have adopted his rule of H-spread in the present analysis, the phonological/phonetic distinction is compatible with

his work, etc. There are two basic differences however: First, Hyman assumes that downstep is triggered by the following sequence:

$$(80) \quad \begin{array}{c} \text{y} \\ | \\ \text{αT} \\ \text{⊖αT} \end{array}$$

That is, a floating H downsteps a L; a floating L downsteps a H. In section 5.3 above, I gave one argument against this position. An additional argument concerns cases like the following:

- (81) a. \grave{a} $\grave{k}\grave{e}$ $\grave{!}k\grave{o}\eta\grave{o}$ $\grave{!!}m\grave{o}$ 'he liked a child'
 b. \grave{a} $\grave{k}\grave{e}$ $\grave{!}k\grave{o}\eta\grave{o}$ $\grave{!}\grave{o}$ $\grave{!}m\grave{o}$ 'he liked (only) a child'

In (81a) we observe a double downstepped sequence H!!H. Hyman and Tadadjeu show by means of examples such as (81b) that such sequences derive from a pattern like the following:²¹

$$(82) \quad \dots \begin{array}{c} V_1 \\ | \\ H \end{array} L_1 \begin{array}{c} V_2 \\ | \\ H \\ \text{V} \end{array} \left[\begin{array}{c} L_2 \\ | \\ V \end{array} \right] \begin{array}{c} V_3 \\ | \\ H \end{array} \dots$$

The pattern in (82) is that of the underlined portion of (81b). When V₂ is lost, the pattern in (83) results.

$$(83) \quad \dots \begin{array}{c} V_1 \\ | \\ H_1 \end{array} L_1 H_2 \left[\begin{array}{c} L_2 \\ | \\ V \end{array} \right] \begin{array}{c} V_3 \\ | \\ H_3 \end{array} \dots$$

According to the proposal for downstep interpretation made in this chapter, the configuration in (83) will create a double downstep

-- both L_1 and L_2 will have a downstepping effect. But with Hyman's proposal (80 above) the representation in (83) would only create a single downstep. Generalizing (80) would not improve matters.

(84) $\textcircled{-\alpha T} \quad \alpha T$

If the restriction about the downstepped tone being linked was removed, then the configuration in (83) should create a triple downstep: L_1 would downstep H_2 , H_2 would downstep L_2 and L_2 would downstep H_3 .

An alternative to modifying the downstep rule in (80) would be to allow the rule of downstep to precede the phonological or morphological rule that results in the tonal configuration in (83). But since the downstep rule must be a rule of the phonetics, such a proposal would be incompatible with the general model given in (5) above.

A second difference between Hyman's analysis and that given here concerns rule ordering. Hyman proposes a kind of 'local ordering' (NB: S.R. Anderson 1974) that he summarizes as follows:

(85) "What we have is a left-to-right free ordering situation...: one starts with the first tone of the phrase and asks, "can this tone serve as a focus for any tone rule?". If yes, then the rule applies. If no, then one moves on to the next tone and asks the same question, and so forth, on to the last tone of the tone phrase."

The analysis given here requires no such ordering principle. Rules are extrinsically ordered and apply in the order given. Left-to-right application is relevant -- Metathesis, for example, applies

iteratively from left-to-right -- but only with respect to the iteration of a single rule.

5.11 Conclusions

An analysis of Dschang has been presented above that proposes two phonetic rules and a number of phonological rules -- all of which apply post-lexically -- to derive surface tonal facts. The two types of rules are distinguished in a number of ways: 1) Post-lexical phonological rules utilize tonal features in strictly binary ways. For example, a + value becomes a - value in the rule of Lowering (58), a tone is deleted (not 'reduced') in L-deletion (58). Phonetic rules can create non-binary representations, as in downstepping. There is no definable finite number of possible pitch levels to be created. 2) Contour tones are impossible in the phonology of Dschang because of the multiple-linking constraint given in (28). Consequently, phonological rules such as H-spread and L-spread entail automatic delinking of tones. Phonetic contour tones are possible, however, as the result of a rule such as Final Lowering (downgliding) that applies in the phonetic component. 3) A phonological rule such as Phrasal L-deletion is conditioned by syntactic category information. Presumably, phonetic rules cannot be so conditioned. 4) All the phonological rules posited precede, and do not interact with, the phonetic rules.

FOOTNOTES: CHAPTER 2

1. The downdrift/downstep phenomenon has been widely discussed in the literature and I will not even attempt to provide a list of references here. Some early work includes Welmers (1959), Winston (1960), Arnott (1964) and Stewart (1965). For additional references see Clements (1980) and Huang (1980).
2. These examples from Igbo are taken from lecture notes from Kay Williamson.
3. This and other Tiv examples are discussed in detail in chapter 5.
4. Note that we must allow limited syntactic conditioning of an interpretive phonetic rule in cases such as the following: Downdrift is suspended in Hausa and Igbo in questions. This means that the phonetic rules are different in these languages in questions and in declarative sentences. Note, however, that such sentence operators do not require reference to constituents or sub-constituents of the sentence.
5. This point was made to me by Morris Halle.
6. In this respect, it is interesting that Leben (1983) argues that the Obligatory Contour Principle applies lexically and not post-lexically.
7. Thanks to Morris Halle for making this clear to me.
8. The assimilation of e to a in this example (and comparable assimilations in other examples) is predictable but will not be discussed here. See Tadadjeu (1977).
9. This is the only example of a prefixless monosyllabic noun with a

!H pattern. Hyman and Tadadjeu (1976) observe that it is optionally realized as H in isolation.

10. Note Hyman (1982).

11. Underlying forms are those proposed by Hyman and Tadadjeu (1976).

12. The conditions for assimilation and deletion will not be discussed here, but see Tadadjeu (1974, 1977) and Hyman and Tadadjeu (1976).

13. 'Underlying' form is a slight misnomer since the lexical form -- that is, the form of the word when it leaves the lexicon -- is built up morphologically and phonologically at the same time. Hence when I refer to the 'underlying' form in a case like (36), this is an expository device that separates out a morphological bracketing by factoring out the phonological effects.

14. Underlying forms in Table 1 differ in certain respects from those of Hyman and Tadadjeu (1976) since they reflect the analysis of this chapter. Surface forms are of course the same.

15. Hyman's formulation does not specify that a H will only spread onto a non-final L as he assumes that the required restriction has to do with a stem vowel vs. non-stem vowel distinction.

16. The precise conditions that trigger Associative V-deletion will not be discussed in this chapter, but see Tadadjeu (1977). A partial formulation of the rule is given in (58) below, and the rule is discussed briefly in section 5.6.

17. Even if H-spread did not apply in the above case (since it is optional across word boundaries) we would still expect Lowering.

18. This suggestion was made to me by Morris Halle.

19. For a detailed discussion of default rules, see Chapter 3.

20. Hyman (1982) has suggested a slightly different convention.

He suggests that H-spread might be generalized to apply to cases

such as (75b) and (76b); the $\begin{array}{c} V \\ / \quad \backslash \\ H \quad H \end{array}$ sequence that would result would



then be simplified to $\begin{array}{c} V \\ | \\ H \end{array}$ by a general convention. The problem with



this approach seems to lie in the optionality of H-spread over

word-boundaries. If H-spread did not take place -- say, in careful

speech -- then the prediction would be that Metathesis could not

apply.

21. Note that the final H of the verb must not undergo Lowering (58).

This is true whether or not the H in question remains linked; see

(81b), for example. This result can be obtained by restricting

Lowering to applying within noun phrases.

CHAPTER 3: UNDERSPECIFICATION

Evidence from tonal systems provides strong support for a theory of phonology that supplies 'unmarked' feature specifications by universal default rules. The role and nature of tonal default rules and how they are incorporated into the overall model of phonology will be examined in this chapter. Special attention will be paid to problems that could result from underspecification, such as the surreptitious replacement of a binary feature system with a ternary one.

In this chapter, I will first discuss evidence for tonal underspecification. Although the recognition that tone may be unspecified in lexical entries is not new, it will be shown that 'spreading' is not the only mechanism for assigning tonal values to unspecified tone-bearing units. Tonal phenomena, just like 'segmental' phenomena, are demonstrated to require the inclusion in phonological theory of default rules assigning unmarked feature specifications. The nature of tonal default specifications will be examined and it will be proposed that they consist of the insertion of a tonal autosegment. The question of how to order default rules with respect to other phonological rules will be discussed. This question is particularly interesting because there is evidence that tonal default rules must in some cases apply after a number of post-lexical rules. Hence one must address the issue of where default insertion of tones takes place -- lexically? -- post-lexically? -- phonetically?

After giving arguments for tonal default rules, I will try to show that the theoretical box that has been opened by allowing underspecification is not Pandora's. A constraint on the utilization of underspecification will be proposed and the possibility that the ordering of default rules can be predicted by universal principles will be discussed.

1. Default rules

The cornerstones of the approach of this chapter are that spreading of tones is not automatic and that tone-bearing units not assigned tones either by the morphology or by rule get tones by default. The idea that certain tonal specifications should be filled in by default rules is not a new idea. For example, an early proposal along these lines was made by Schachter (1969). It has, moreover, been recognised by virtually all scholars working on tone that certain syllables or morphemes have no inherent tone of their own but acquire tone as a function of the tonal properties of adjacent syllables or morphemes. Autosegmental theory (Goldsmith 1976, Clements and Ford 1979, etc.) makes fundamental use of the assumption that tone-bearing units may be unspecified for tone underlyingly. In the typical cases, it has been suggested, even when a morpheme includes tones underlyingly such tones are not pre-linked to vowels. On the contrary, the assignment of tones to vowels takes place as the result of conventions of association.

For example in Margi, a Chadic language of Nigeria, ¹ vowels

of stems and affixes are underlyingly unspecified for tone. In some cases the morphemes of which such vowels are a part may include tones and in other cases they do not. In all cases the tones (if any) are not pre-linked to particular vowels.

For example, in (1) tones are assigned by left-to-right linking of free tones to free vowels. In addition, the left-over tone in (1c) is linked to form a contour tone.

- (1) a. gha → ghā 'to shoot'
 |
 L
- b. ta → tá 'to cook'
 |
 H
- c. nu → nu → nǔ 'to mould (pottery)'
 | | |
 L H L H

In (2) and (3) we observe the effects of adding an inherently toneless suffix to the verb stems in (1). In (2), na receives a tonal specification by the spreading of a linked tone from left to right.

- (2) a. gha + na → ghānā 'to shoot away'
 | |
 L L
- b. ta + na → tánā 'to cook and put aside'
 | |
 H H

In (3), left-to-right linking as seen in (1) -- applying prior to the linking rule observed in (1c) -- assigns a tone to na.

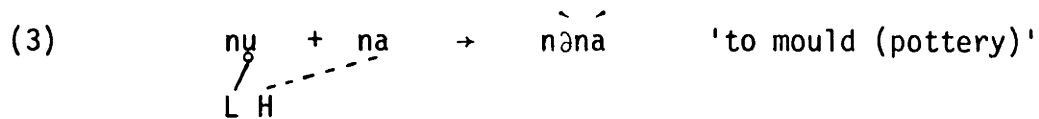

An important point to note about the above examples is that even though the stem morphemes include tones, the surface pattern of linkings is predictable without underlyingly assigning tones to vowels. In fact we will see in chapter 5 that to assume that vowels in Margi are underlyingly specified for tone (that is, linked to tones) creates a number of undesirable results.

The Margi case illustrated above is of interest because it represents a typical pattern attested in a considerable number of tone languages. It is important therefore to consider its implications carefully. The fact that assignment of tones to vowels is predictable means that a grammar of Margi will be missing a generalization unless, 1) it analyses vowels as inherently toneless and 2) it assigns tones to vowels in the phonological component of the grammar. The important question is whether the assignment of tones to vowels is by language-specific rule or by universal convention. In most autosegmental treatments of such questions (for example, Goldsmith 1976 and Clements and Ford 1979) it has been proposed that the types of associations observed in (1-3) are accomplished by universal convention. While statements of the precise conventions have varied somewhat ², it has generally been assumed that left-to-right linking of tones as well as spreading of tones occurs automatically.

To summarize, a central tenet of autosegmental theory is that

'P-units' (the class of slots to which autosegments are linked) may be underlyingly unspecified for (that is, unlinked to) a 'P-segment' (a member of the class of autosegments). Specification of P-units for P-segments is accomplished by a set of language-independent association conventions, which minimally include a left-to-right linking of free P-segments to free P-units and a convention for spreading P-segments onto left-over P-units.

The above proposal is interesting because of its marked difference from 'segmental' proposals. In dealing with 'segmental' features, it is not assumed that a segment unspecified for feature F will get its value for that feature as a function of an adjacent segment. Such may be the case but is not necessarily so. For example, the voicing of the first member of an obstruent cluster is predictable in English -- it agrees in voicing with the second consonant of the cluster -- and need not, therefore, be specified in the lexicon.³ Consider a[dz]e, Ma[zd]a, hu[kst]er, ca[ft]an, etc. In this case, the rule that specifies the value of voicing must refer to an adjacent segment, namely the following obstruent. But where no such special rule exists, a feature value may be assigned by a context-free fill-in rule, such as a general rule assigning the value [-Voice] to obstruents.

But whereas in the segmental realm feature values may or may not be contextually determined, it has generally been assumed that as far as autosegmental representations are concerned, feature values are always contextually determined -- that is, tonal values, for example, are determined by linking free tones or by extending the domain of a linked tone by spreading.

In the following sections, I will argue that such a distinction between 'segmental' and 'autosegmental' representations is incorrect. Autosegments do not spread automatically; context-free autosegmental fill-in rules exist. Spreading of tones is a widespread phenomenon -- just as voicing assimilation and homorganic nasal assimilation are common processes. Nevertheless, I will argue that such phenomena are rule governed and when, in a tonal system, some type of spreading or tone assignment by rule does not take place, then a tonal default value is assigned.

2. Yala Ikom Reduplication

The first case I wish to consider involves the formation of the verbal noun or gerund in Yala Ikom, a Kwa language of Nigeria. I will show that in Yala, a language that contrasts three tones, H, M and L, the M-tone should be underlyingly unspecified. Consequently toneless V-slots will be assigned a M by the following default rule:

$$(4) \quad \text{Default M-insertion: } \textcircled{V} \rightarrow \begin{array}{c} V \\ | \\ M \end{array}$$

Armstrong (1968) shows that in Yala there is a rule that turns a L-tone into a falling tone after a H-tone. For example, the L-tone verb lɛ 'have' becomes falling after the H-tone pronoun ɔ in the following example:

$$(5) \quad \begin{array}{ccccccc} \textcircled{\text{ɔ}} & + & \textcircled{\text{lɛ}} & + & \textcircled{\text{ɔ}} & \textcircled{\text{nyɑ}} & \\ | & & | & & | & | & \\ \text{H} & & \text{L} & & \text{L} & \text{M} & \\ \text{he} & & \text{have} & & \text{woman} & & \end{array} \rightarrow \begin{array}{ccc} \textcircled{\text{ɔ}} & \textcircled{\text{lɛ}} & \textcircled{\text{nyɑ}} \\ | & | & | \\ \text{H} & \text{L} & \text{M} \end{array} \rightarrow \begin{array}{ccc} \textcircled{\text{ɔ}} & \textcircled{\text{lɛ}} & \textcircled{\text{nyɑ}} \\ | & | & | \\ \text{H} & \text{L} & \text{M} \end{array}$$

The representation of (5) on the surface is therefore $\acute{o} \text{ l}^{\hat{a}}\text{ny}\bar{a}$ 'he is married'. Armstrong also shows that the rule that creates falling tones is blocked by the presence of a 'latent' (floating) tone intervening between the H and the linked L. For example, in $\acute{o} \text{ !}^{\hat{a}}\text{be}\bar{h}\bar{e}$ 'he called', the initial tone of the verb stem is level low, not falling (indicated in the Yala transcription by the '!').

$$(6) \quad \begin{array}{ccc} o + & \text{behe} & \rightarrow \quad \acute{o} \text{ !}^{\hat{a}}\text{be}\bar{h}\bar{e} \quad \text{'he called'} \\ | & | & \\ \text{H} & \text{L L M} & \end{array}$$

Let us now turn to the verbal nouns.

The formation of verbal nouns involves reduplicating the verb stem and prefixing \acute{o} or \acute{u} -- as dictated by vowel harmony considerations. When a L-tone or M-tone stem is reduplicated, Armstrong shows that the tones on the reduplicated portion of the word are M.⁴

$$(7) \quad \begin{array}{lll} \text{a. } \acute{o} + \text{ny}\bar{i} + \text{ny}\bar{i} & \text{'burying'} & \acute{a} \text{ ny}\bar{i} \quad \text{'you buried'} \\ \text{b. } \acute{o} + \text{b}\bar{i} + \text{b}\bar{i} & \text{'carrying'} & \acute{a} \text{ b}\bar{i} \quad \text{'you carried'} \\ \text{c. } \acute{u} + \text{h}\bar{a}\bar{r}\bar{a} + \text{h}\bar{a}\bar{r}\bar{a} & \text{'accompanying'} & \acute{a} \text{ h}\bar{a}\bar{r}\bar{a} \quad \text{'you accompanied'} \end{array}$$

Although the cases in (7) could be accounted for by assuming that the reduplicated syllables are prespecified as bearing a M-tone -- where M would be a fully specified autosegment -- consideration of the verbal nouns of stems such as in (6) shows that the M-tone reduplicated syllables must be unspecified for tone underlyingly. Such cases depart from the normal generalization for L-tone and M-tone stems in that the reduplicated stem bears a LM tone pattern.

Consider for example the verbal noun ɔgbɛhɛ̄gbɛhɛ̄ 'chopping'. The stem !gbɛhɛ̄ 'chop' is one of the stems that has an initial floating L-tone that blocks formation of a falling tone. If we assume that the mid tone in Yala is assigned by default then (8) shows the underlying form of !gbɛhɛ̄ .

$$(8) \quad \left[\begin{array}{c} \text{gbɛhɛ} \\ | \\ \text{L} \end{array} \right]$$

We saw in (7a) and (7c) that L-tones are not copied under reduplication. Hence the derivation of the verbal noun for !gbɛhɛ̄ will proceed as follows: First, the stem will undergo reduplication.

$$(9) \text{ a.} \quad \text{gbɛhɛ} + \text{gbɛhɛ} \\ \quad \quad \quad \quad \quad | \\ \quad \quad \quad \quad \quad \text{L} \quad \text{L}$$

After reduplication, normal left-to-right association conventions will apply.

$$\text{b.} \quad \text{gbɛhɛ} + \text{gbɛhɛ} \\ \quad \quad \quad \quad \quad \quad \quad | \\ \quad \quad \quad \quad \quad \quad \quad \text{L} \quad \text{L}$$

Prefixation takes place and the association conventions apply.

$$\text{c.} \quad \text{ɔ} + \text{gbɛhɛ} + \text{gbɛhɛ} \\ \quad \quad \quad \quad \quad | \quad \quad | \\ \quad \quad \quad \quad \quad \text{L} \quad \quad \text{L} \quad \quad \text{L}$$

Finally, M-tones are assigned by default to the left-over vowels.

d. ɔ + gbɛhɛ + gbɛhɛ
 | | | | |
 L L M L M

Hence we correctly derive ɔgbɛhɛgbɛhɛ.

By assuming that M-tones are unspecified in Yala and that spreading of tones is not automatic, we account for why it is precisely the class of verbs that blocks spreading of a H from a pronoun that also derives a L M sequence on the reduplicated stem of the verbal noun. If M-tones were lexically specified then some ad hoc rule would have to be added to the grammar of Yala to create the L M pattern on reduplicated stems in such cases.

3. Yoruba

The next language that I wish to look at is Yoruba, a Kwa language spoken primarily in Nigeria and Benin. Yoruba, like Yala, has a three-way tonal contrast, H, M, L and like Yala, I will argue that the M-tone in Yoruba is unspecified underlyingly and assigned by a default rule as in (4) above.

The canonical verb in Yoruba has a CV structure while the canonical noun is VCV. Verbs may bear any of the three possible tones (eg. H: kò 'build', M: kò 'sing', L: kò 'refuse') while nouns are restricted to bearing M or L on their initial vowel. H-tone initial nouns do exist but in non-native vocabulary such as tíṣà 'teacher' (from English) and tákàdà 'paper' (from Hausa) or in derived vocabulary such as dídun 'sweetness' derived from the verb dùn 'to be sweet'.

3.1 L-tone Deletion⁵

When a L-tone monosyllabic verb precedes an object, the verb will be realized on a M-tone.⁶

- (10) a. [rò]_V 'to be soft'
 b. ó [rò]_V [rírò èkò]_{NP} 'it feels soft like èkò'
- (11) a. [dùn]_V 'to be sweet'
 b. ó [dùn]_V [dídùn òyìn]_{NP} 'it tastes sweet like honey'

This L~M neutralization is accounted for by a rule of L-deletion:

- (12) L-deletion: L → φ / ___]_V [_{NP}

The derivation of (11b), for example, would proceed as follows. In the input to the post-lexical phonology, M-tones are not specified.

- (13) a. o [dun]_V [didun oyin]_{NP}
 | | | |
 H L H L

The L of the verb dun is deleted by L-deletion (12).

- b. o [dun]_V [didun oyin]_{NP}
 | | | |
 H φ H L

All vowels that do not bear a tone are subsequently assigned M.

- c. o dun didun oyin
 | | | | | |
 H M H L M M

Hence we correctly derive ó dūn dídùn òyīn.

In the above example I have assumed that M-tones are unspecified underlyingly although nothing in the facts of L-deletion so far presented would force us to this analysis. But with the facts of L-deletion established (if not the form of the rule), we are now in a position to discuss evidence for underspecification.

3.2 V-deletion

The basic word order in Yoruba is SVO, so typically a transitive sentence will contain a sequence $[..[CV]_V [VCV]_{NP}..]$. In connected speech, it is common that one of the abutting vowels in such a sequence is deleted. The precise determination of which vowel deletes is a complex issue that will not be discussed here.⁷ But independent of this issue, the tonal configuration that results after deletion can be predicted from the underlying tonal pattern.

In the following examples, I illustrate the effect of V-deletion on M-tone and L-tone initial nouns in combination with H-tone, M-tone and L-tone verbs. H-tone initial nouns are not relevant for considerations of V-deletion since they are consonant-initial. Concerning notation, the dot in the derived forms in (15) is the 'assimilated low tone' of Bamgboṣe (1966). Its significance will be discussed shortly.

- (14) H-tone verb + M-tone initial noun⁸
- a. rí ĩgbá → rígbá 'see a calabash'
- b. rí āşō → ráşō 'see cloth'
- c. rí ọ̀bẹ̀ → rọ̀bẹ̀ 'see soup'
- (15) H-tone verb + L-tone initial noun
- a. fẹ̀ ĩgbá → fẹ̀.gbá 'want a garden egg'
- b. rí ọ̀bẹ̀ → rọ̀.bẹ̀ 'see a knife'
- c. rí apò → rá.pò 'see a bag'
- (16) M-tone verb + M-tone initial noun
- a. şē ĩşé → şĩşé 'work (do work)'
- b. mū ēmū → mēmū 'drink palm-wine'
- c. pā ējò → pējò 'kill a snake'
- (17) M-tone verb + L-tone initial noun
- a. şē ọ̀rẹ̀ → şọ̀rẹ̀ 'to be friends'
- b. pā ọ̀bọ̀ → pọ̀bọ̀ 'kill a monkey'
- c. şē ọ̀fọ̀ → sọ̀fọ̀ 'mourn'
- (18) L-tone verb + M-tone initial noun
- a. dī ọ̀jú → dījú 'close eye'
- b. wọ̀ āşō → wọ̀şō 'wear cloth'
- c. jà ọ̀lẹ̀ → jālẹ̀ 'steal'
- (19) L-tone verb + L-tone initial noun
- a. kà iwé → kawé 'read'
- b. rá ọ̀bẹ̀ → rọ̀bẹ̀ 'buy a knife'
- c. là ọ̀nà → lana 'plan out'

The first fact to notice about the above examples is that the tonal forms that result when the verb is Mid are the same as when the verb is Low. This is accounted for by ordering the rule of L-deletion (12) before the rule of V-deletion presently under consideration.

Secondly, we observe that if the verb is lexically H, then no matter which vowel is deleted, the first vowel of the derived CVCV sequence will be H (examples 14 & 15). If the verb is M (either lexically or as a result of L-deletion (12)), then the tonal pattern of the CVCV output of deletion will be the same as the tonal pattern of the noun in isolation (examples 16 - 19). If the first vowel of the noun is M, then that M disappears completely in the form that has undergone deletion (example 14).

The above facts can be explained if we assume that M-tones are underlyingly unspecified in Yoruba. That is, M-toned vowels are underlyingly toneless and receive their tone by Default M-insertion (4). By simply assuming that Default M-insertion applies after the phrase-level rule of vowel deletion, we account completely for the 'loss' of the M-tone under vowel deletion. Consider the derivation of (14a):

(20) [=14a]

ri igba
| |
H H

r igba
| |
i H

rígba

V-deletion & Association Conventions

Since there is no tone lexically present on the first vowel of ĩgbá 'calabash', this vowel turns up on a M-tone in isolation. However, in a case such as (20), the deletion of a vowel results in the H of rí 'see' linking to the previously toneless vowel of ĩgbá. Consequently, default M-insertion (4) is not required and we obtain the surface pattern H H.

In (21), we observe that the relinking that occurs after vowel deletion is a strictly one-to-one linking. The H of rí does not spread onto the second vowel of āṣṓ 'cloth' in deriving rāṣṓ.

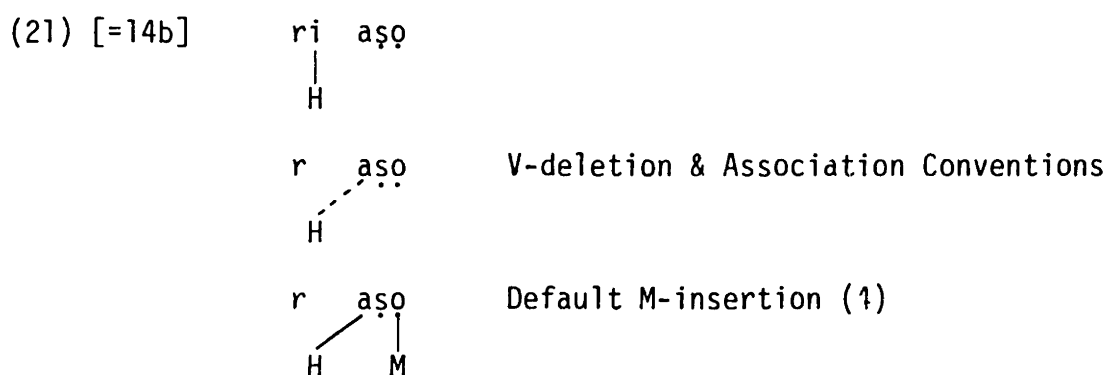

It is immaterial whether the vowel deleted is the first or the second one. Hence in an example like (22), we observe that one-to-one linking applying after V-deletion assigns the tone of the noun to the toneless vowel of the verb, whereas in (20) and (21) the tone of the verb is assigned to the first vowel of the noun in deriving kàwé.

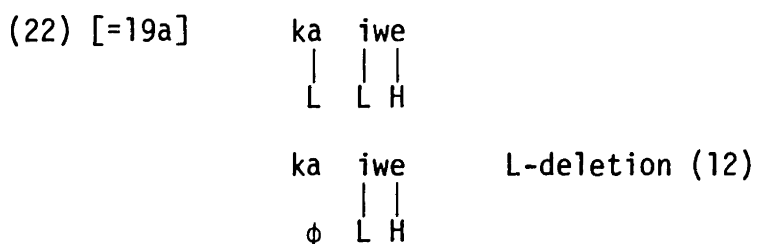

ka we
 - - -
 L H

V-deletion & Association Conventions

In (23), we see that if it is the toneless (ie., Mid) vowel itself that is deleted, then there is no effect on tonal linkings.

(23) [=17c] şe ofo
 | |
 L L

 ş ofo V-deletion
 | |
 L L

 ş̣ of̣
 ş̣of̣

This fact is true whether it is the vowel of the verb that is deleted (as in 23) or the first vowel of the noun (as in 24).

(24) wa igi 'look for firewood'
 |
 H

 wa gi V-deletion
 |
 H

 wa gi Default M-insertion (4)
 | |
 H M

 wāgī

Similarly, if two toneless vowels are adjacent and one is deleted, then the vowel that is left predictably surfaces as M.

- (25) [=16a] $\begin{array}{c} \text{ʃe} \quad \text{iʃe} \\ \quad \quad | \\ \quad \quad \text{H} \end{array}$
- $\begin{array}{c} \text{ʃ} \quad \text{iʃe} \\ \quad \quad | \\ \quad \quad \text{H} \end{array}$ V-deletion
- $\begin{array}{c} \text{ʃ} \quad \text{iʃe} \\ | \quad | \\ \text{M} \text{H} \end{array}$ Default M-insertion (4)
- $\begin{array}{c} \text{ʃiʃe} \\ \quad \quad \acute{} \end{array}$

By analysing M-tones as lexically toneless, we account for all of the above examples. Such cases argue for several things: 1. M-tones are supplied by a default rule. 2. Association conventions apply to the output of phonological rules. 3. The association conventions link tones to tone-bearing units in a strict one-to-one manner; spreading of tones is not automatic. 4. Default rules can apply to the output of phonological rules.

Before examining the cases in (15) that involve the 'assimilated low tone', I must motivate two additional rules. The first is a rule that creates rising tones. When a H-tone immediately follows a L-tone, the H-tone becomes rising. Hence underlying L H nouns such as the following are realized as L R (R = rising): iwe^v 'book', igba^v 'garden egg', ore^v 'friend'. This fact can be accounted for by the following rule that spreads a L-tone.

- (26) L-spread: ⁹
- $\begin{array}{c} \text{V} \\ \text{---} \diagup \\ \text{L} \quad \text{H} \end{array}$

Interestingly, the rule of L-spread does not trigger delinking of the linked H-tone, unlike the comparable spreading rules in Dschang (see chapter 2, sections 5.2.2 and 5.4.1). It appears to be the case that lexically in Yoruba there is a one-to-one constraint on tone/tone-bearing unit relations just as there is in Dschang. In Dschang, however, this constraint continues to hold post-lexically while in Yoruba, at the post-lexical stratum it is possible to create multiple linkings.¹⁰

A word such as iwé will be derived as follows:

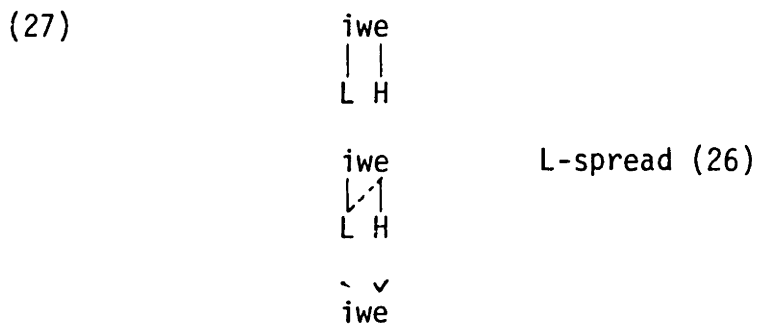

Note that L-spread applies to the output of V-deletion, so in a case like (22) above the surface form will have a rising tone:

kawé.

Turning to the cases in (15), we observe that the tonal patterns that result from V-deletion are somewhat more complicated. The reason for this turns out to be completely unsurprising -- in all the cases in (15), there is a lexical tone on both of the vowels that are the input to V-deletion. Consider the derivation of a phrase such as ké.kò 'to learn a lesson'.

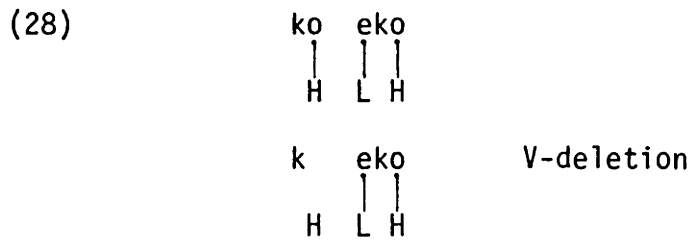

In such a case, V-deletion creates a situation where the H of the verb is floating. But to derive the correct surface form, the H must relink to the following vowel. This is accounted for by the rule of H-spread.

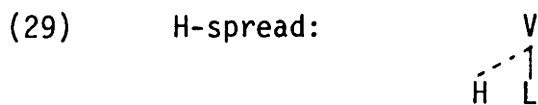

This rule is independently motivated in sequences like ó dún 'it is tasty' and ó pò 'it is plentiful', where there is a sharp falling tone on dún and pò. In fact, it may well be possible to collapse the rules of L-spread (26) and H-spread (29).¹¹

H-spread (29) will apply to the output of (28) to create (30a).



L-spread (26) will also apply to such a form giving the following result:

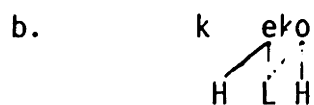

The configuration in (30b) corresponds basically to the form given in Abraham (1958): $\overset{\wedge}{\underset{\checkmark}{k\acute{e}k\grave{o}}}$ although Abraham transcribed such cases as having long vowels. Other scholars generally agree that the first vowel in such cases is not long (NB: Ward 1952, Bamgboṣe 1966, Courtenay 1971). What is not as clear however, is whether there is nevertheless a falling tone on the first vowel in such cases. Bamgboṣe observes that in a series of spectrograms made of such cases, "only one out of four shows a high-falling pitch for the vowels in contact". (Bamgboṣe 1966 p.4) There is some indication that the fall or lack of fall in such cases is attributable to dialect differences ¹², where the normal case for Standard Yoruba is for the rule of H-spread (29) to be followed by an additional rule that delinks the L.

(31) Delinking (Standard Yoruba):

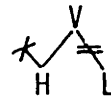

This rule states that a L is delinked from a falling tone sequence when the H of that sequence is not linked to a preceding tone-bearing unit. Note that delinking cannot be automatic since, a) there are dialects that do not delink and b) as we have seen above, contour tones are possible (and common) post-lexically in Yoruba.

With a case such as $\overset{\wedge}{\underset{\checkmark}{k\acute{e}.k\grave{o}}}$, Delinking (31) will apply to the output of (30b) as illustrated below:

(32) $k \quad \overset{\wedge}{\underset{\checkmark}{e k o}} \quad \rightarrow \quad \overset{\wedge}{\underset{\checkmark}{k\acute{e}k\grave{o}}}$

Bamgboṣe (1966) noted that when a H-tone displaces a L-tone in cases such as (32) that the following tone nevertheless continues to behave phonetically as though there is a preceding L-tone. He proposes that such an assimilated low tone be represented orthographically in cases such as ké.kò by a dot that indicates that the following H-tone will have the phonetic shape appropriate to a H-tone following a L-tone.

From the point of view of underspecification, the crucial aspect of the above discussion is the following: When a phrase of the character

$$\left. \begin{array}{c} \dots H \\ \downarrow \\ V_1 \end{array} \right] \left[\begin{array}{c} L \dots \\ \downarrow \\ V_2 \end{array} \right] \dots$$

V N

surface tonal pattern is a function of certain rules in conjunction with both the H and the L that are present underlyingly. When a M occurs in such a configuration on either V_1 or V_2 , it can have no effect on the tonal outcome since it has not yet been inserted at that stage of the derivation.

Turning to the two remaining cases of (15) involving the assimilated low tone, I will first look briefly at a case like ri.apò → ra.pò [=15c]. First of all V-deletion takes place.

- (33) a. ri apo
 | | |
 H L L
- b. r apo V-deletion
 | | |
 H L L

H-spread (29) is applicable, but L-spread (26) is not:

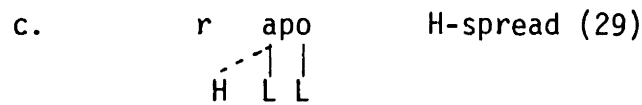

Delinking then applies to derive the following configuration:

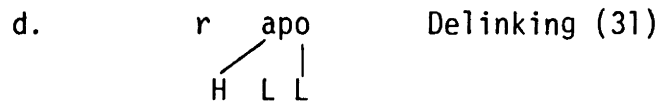

According to Bamgboṣe, the basic difference phonetically between a H L sequence and a H . L sequence is that the former is characterized by a sharp falling tone on the L-toned mora while in the latter case, there is either no fall on the second vowel or the fall is less sharp. This difference follows automatically from the analysis presented in this chapter. Compare the derivation in (33) with that of a phrase like ri oḃe → roḃe [=14c].

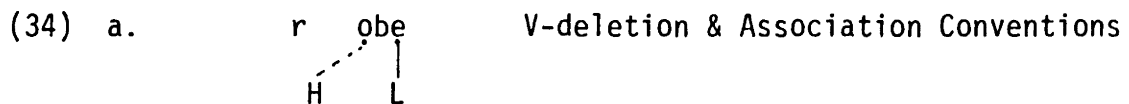

H-spread will apply creating a falling tone on the final syllable of oḃe.

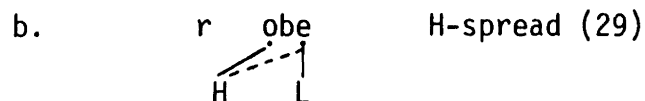

Delinking (31) is inapplicable in (34) since the H is multiply linked.

Consequently this analysis correctly predicts that the form in

(34) will be characterized by a falling tone on the final mora while the form in (33) will be characterized by a level low tone on the last mora. ¹³

The last case in (15) to be considered is an interesting one because it involves a mid-tone on the second vowel of the noun -- where such a mid-tone is lexically unspecified according to the hypothesis of this chapter. Consider the result of vowel deletion and H-spread in the derivation of r_o.b_e [=15b].

- (35) a. r i o b e
 | |
 H L
- b. r o b e V-deletion
 | |
 H L
- c. r o b e H-spread (29)
 | |
 H L

As is, the configuration in (35) would derive the non-standard form r_ob_e. To derive the standard form, Delinking (31) will apply to the output of (35) giving us the form in (36).

- (36) r o b e Delinking (31)
 | |
 H L

To derive the correct surface form, namely r_o¹.b_e, the floating L in (36) must not link to the free vowel e (*r_ob_e). There are two basic ways of achieving this result. The first would be to assign default values prior to the rule of Delinking. Under this approach,

Default M-insertion would apply to the output of (25) to give us (37a).

(37) a. r obe Default M-insertion (4)
 / | |
 H L M

Delinking would then derive (37b).

b. r obe Delinking (31)
 / | |
 H L M

While this seems like a straightforward solution, it has the undesirable consequence of extrinsically ordering a default rule with respect to language specific phonological rules. This issue will be discussed in section 6.2.2 of this chapter as well as section 7. of chapter 6.

An alternative approach would be to assume that the association conventions do not apply to the output of Delinking. Hence Delinking would apply as in the derivation of (36) from (35) above. Default M-insertion would then apply to derive (38) below.

(38) r obe
 / | |
 H L M

For this approach to work, one must impose a condition on the re-application of the association conventions. Such a condition could take various forms. One might, for example, propose that the association conventions apply only once per scanning of the

phonological rules. That is, the association conventions would apply only once per stratum.¹⁴ But this solution would require the addition of a new rule to the grammar to account for the linking in examples such as (20), (21) and (22) above. Moreover, this new rule would simply duplicate the effect of the association conventions. There is also evidence from other languages to suggest that reapplication of the association conventions is in some cases automatic. We will see one such case in the discussion of Tiv in chapter 6, and another case in the discussion of Margi in chapter 5.

An alternative possibility is to assume that when a rule specifically delinks an autosegment, then the association conventions do not apply to relink that segment.¹⁵

(39) Relinking condition: When a rule of the form $X \rightarrow F$ applies,

F is not subject to reassociation by convention on that stratum.

Some condition such as (39) would seem to be required in order to prevent cases from arising where an iterative rule would delink an autosegment, which would then relink to the same core slot, be delinked by the same rule, relink by convention, etc., etc.

Further research in this area is clearly required. One relevant case in Tonga will be discussed in chapter 4. For a discussion of additional Yoruba cases that are relevant for this issue, see Akinlabi (in preparation). Also for additional discussion of the downstepped M in Yoruba, see Bamgboṣe (1966) and Courtenay (1971).

3.3 High Tone Concord

The asymmetry between Mid tones on the one hand and Low and High tones on the other is not restricted to cases of V-deletion. Consider the tonal behaviour of the subject in sentences such as the following for example:

- (40) a. Ş̣egūn ò l̄õ 'Ş̣egun did not go'
 b. Ş̣egūn á l̄õ 'Ş̣egun will go'
- (41) a. Ş̣egún l̄õ 'Ş̣egun went'
 b. Ş̣egún tī l̄õ 'Ş̣egun has gone'
 c. Ş̣egún á l̄õ 'Ş̣egun will go'

In the sentences in (40), the H M pattern that is attested on the noun Ş̣egūn in isolation is also observed in subject position. In the sentences in (41), however, the isolation H M pattern has been replaced by a H H tonal shape. This type of alternation has received considerable attention in the literature, including Bamgboşe (1966, 1980), Fresco (1970), Stahlke (1974) and Awobuluyi (1975). It has been proposed that these alternations are the result of a H-tone marker that occurs/is inserted between the subject and the following verb phrase. Analyses differ as to whether this marker is to be assigned a segmental shape underlyingly or should be considered purely tonal. Analyses also differ considerably as to what the function of this H-tone marker is. In this section, I will be concerned solely with the effect of the H-tone marker on the preceding noun as its precise function is not crucial to the point at hand.

Following Akinlabi (in preparation) I will analyse the H-tone marker as a H-tone autosegment introduced in the syntax as the first element to the right of the subject noun phrase.¹⁶ By the rule of H-tone linking, this autosegment will be associated to the first vowel to the left of the H-tone marker.

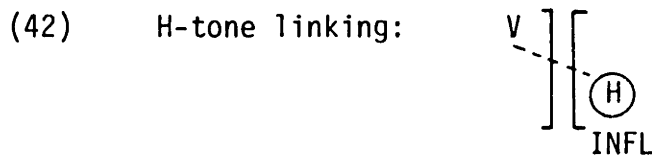

I will assume that the H-tone is present in the constituent INFL in a set of cases definable in terms of tense, polarity, etc. but the reader is referred to Akinlabi (in preparation) for discussion of a possibility that the H-tone marker is present even in some cases where it is not linked to the left. Hence for the purposes of this chapter, I will assume that the H-tone marker is present in (41) but absent in (40). (Note its optionality in (40b) as opposed to (41c))

Consider therefore the effect of the H-tone marker on nouns which end in the three possible tones of Yoruba:

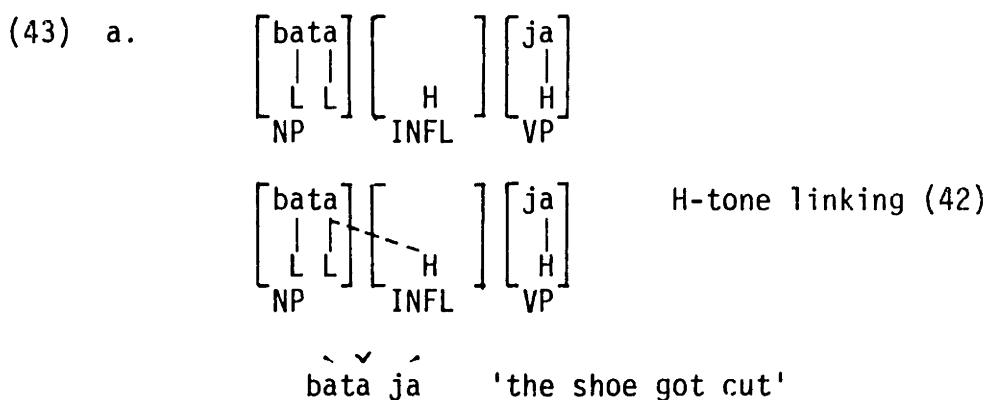

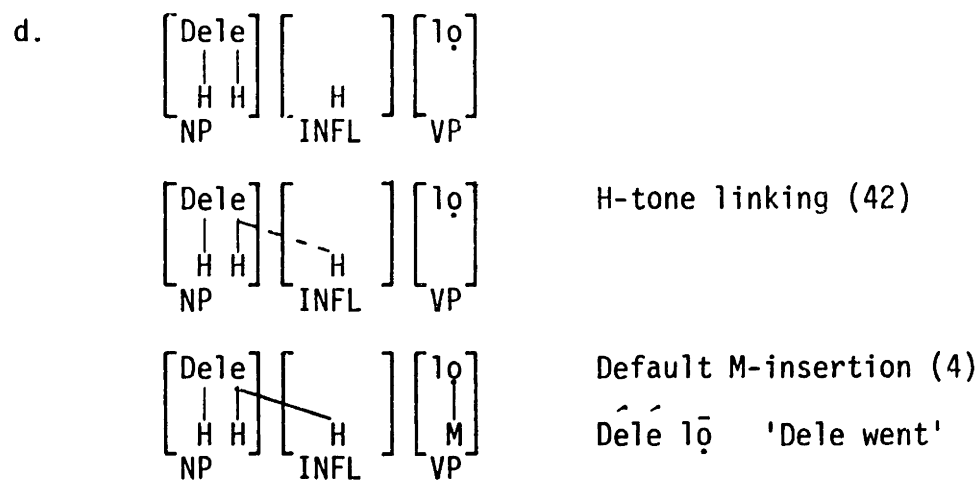
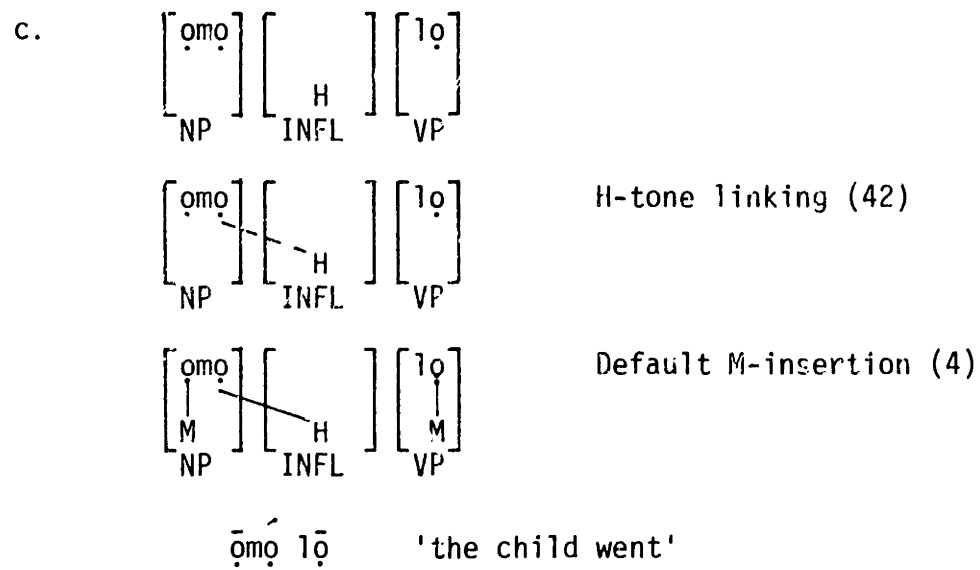
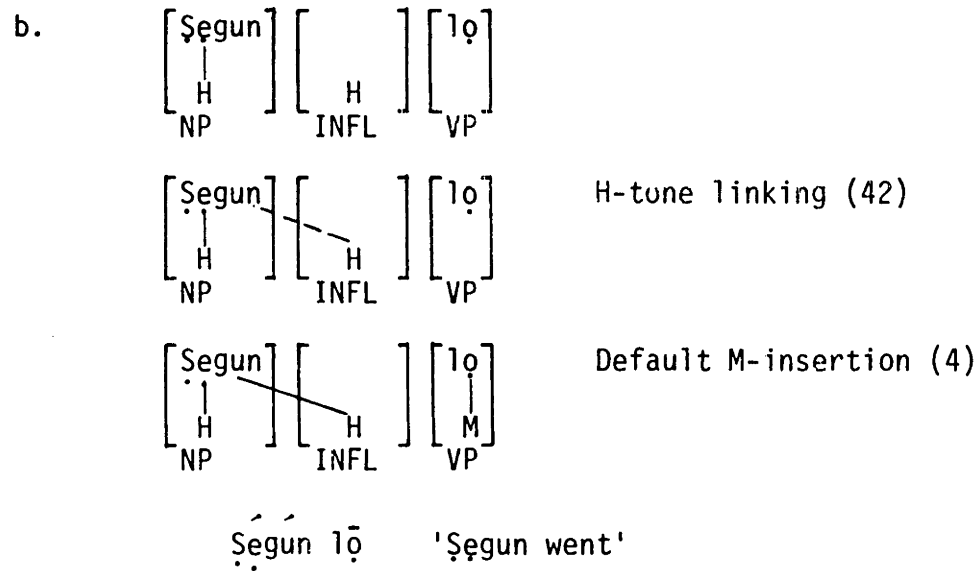

I assume that the H-tone linking rule (42) belongs to the class of 'Initial Tone Association Rules' discussed by Clements and Ford (1979), Laughren (1983), etc. Consequently, H-tone linking will apply prior to the Association Conventions.

Given the above analysis, we predict the correct surface forms in all cases. When the H-tone marker links to a H-tone vowel (43d), there is no tonal effect. When it links to a L-tone vowel, there is a rising tone (43a). And -- crucial to this chapter -- when the H-tone links to a 'mid'-tone vowel, (43b) and (43c), the 'mid' tone is lost completely. This follows automatically within an analysis where the M-tone is unspecified underlyingly.

3.4 Conclusions

The phenomena from Yoruba discussed above allow us to make a number of conclusions about rules of default. First of all, a couple of issues need to be made clear. The analysis of Yoruba and Yala presented above depends crucially on allowing certain tone-bearing units to be unspecified for tone underlyingly. This, in itself, is not an innovation. It has always been crucial for autosegmental theory that one possible type of underlying representation is a lexical entry where no tonal value is specified.

Where the present proposal differs from most earlier work is that tonal specifications can be assigned by default rules instead of always by linking and spreading conventions.

Two distinct claims are being made: 1) The theory of universal grammar supplies rules assigning default values for autosegmentally represented feature. 2) A substantive claim is being made about which values are the default values for tonal features.

3.4.1 Default value

The evidence from Yoruba supports the proposal made for Yala that the default tone in a three-tone system is Mid. It was shown that vowels that surface as Mid should be unspecified for tone underlyingly; only if such vowels do not become linked to an autosegment during the course of the derivation do they surface as M. This approach explains the asymmetry between H and L on the one hand, and M on the other, in terms of the presence vs. the absence of a tonal autosegment.

The proposal that M is the default value in a three-tone system receives support from Chinese languages as well as African. Wright (1983) has argued that in Chaozhcu and in Amoy Mid tones constitute the default case. And concerning a four-tone system, Kaye and Koopman (1982) argue that M is the default tone in Bete, a Kru language of the Ivory Coast.

3.4.2 Core values vs. autosegments

In chapter 1, the issue was raised as to whether default values are represented on a special phonemic tier or as autosegments on the tonal tier. The Yoruba examples of downstepped M-tones constitute a strong argument for viewing default tones as autosegments. In a case like r_o[!]b_e (34 - 38), downstep can be trivially derived from a representation where the M-tone is an autosegment:

(44) [=38]

r	o	b	e
		/	
		H	L M

However, if M-tones are assigned as a core value (as in 45), then it is not obvious how the phonetic downstepping could be derived.

(45)

r	o	b	e
	[M]	[M]	
	H	L	

3.4.3 Association Conventions

It has been suggested that the Association Conventions apply

wherever possible throughout the derivation. They would apply, for example, when an autosegment is set afloat as the result of a rule of vowel deletion. They do not apply, however, to an autosegment specifically delinked by rule.

The analysis of this chapter relies crucially on a version of the Association Conventions where tone-spreading is not automatic; otherwise nouns such as ile 'house' and obẹ 'knife' should surface as * ílẹ́ and * òbẹ̀, instead of īlẹ́ and òbẹ̀.

3.4.4 Post-lexical default rules

It has been shown in this section on Yoruba that insertion of default tones must follow post-lexical rules such as V-deletion and H-tone linking. Both rules are clearly post-lexical since they apply at the level of the syntactic phrase. V-deletion applies between verbs and their objects and H-tone linking applies between the inflectional element of a sentence and the subject noun phrase. Default M-insertion must apply after the post-lexical application of such rules and before the application of a phonetic rule such as the one that downsteps M-tones.

4. Three-way contrasts with two tones

According to the analysis of the preceding section, a verb in Yoruba may have any of three possible underlying representations. It may be linked to a H-tone (46a), it may be linked to a L-tone (46c), or it may be linked to no tone whatsoever in which case it will surface

with a M-tone by default (46b).

- (46) a. mo → m[́]o 'to be clean'
 |
 H
- b. mo → mo → m[̄]o 'to be limited'
 |
 M
- c. mo → m[̀]o 'to know'
 |
 L

This means that a V-slot in Yoruba has three possible lexical representations, all of which receive distinct feature specifications. But such a situation is quite different than that observed in languages like Margi and Tiv. In Margi, for example, verb stems may bear a lexical L, H, or LH pattern or they may be lexically toneless. But the default tone for a toneless vowel is not M but L.

In (47) we observe the various tonal possibilities for H and L tone stems and suffixes in Margi.

- (47) a. ta + ba → tábá 'to cook all'
 H H
 cook
- b. na + dá → nádá 'give me'
 H L
 give me
- c. mbu + ngàri → mbùngárí 'to sew on to'
 L H
 sew on to
- d. ptsá + 'ya → ptsá'ya 'roast us'
 L L
 roast us

internal composition.

Yip (1980) and Clements (1980) propose hierarchical systems of tonal features. Yip proposes that the feature [\pm Upper (Register)] functions to divide the overall pitch range into two 'registers'. Her second feature [\pm High Tone] divides each register into two sub-registers. Following a suggestion by Morris Halle, I will rename her second feature [\pm Raised] to distinguish it clearly from the segmental feature [\pm High] and to avoid any suggestion that [+High Tone] implies a H autosegment.

Yip's system identifies four basic pitch levels as shown in (50) below.

(50)	+ Upper	+ Raised	H
		- Raised	HM
	- Upper	+ Raised	M
		- Raised	L

Clements' proposal is quite similar to that of Yip's except that instead of the two features that Yip proposes, he assumes a single feature used more than once to create a tonal hierarchy. For basic arguments for this type of hierarchical tonal feature system, the reader is referred to Yip (1980) and Clements (1980).

Assuming the feature system in (50), how should default rules be

formulated? There are several important points to consider: 1. The strongest hypothesis concerning default rules is that they are supplied by universal grammar. 2. If default rules are supplied by universal grammar, then how do we get both L and M to emerge as default values for tone? 3. For a given language, can we predict whether the default tone will be M or L?

Both M and L are specified [-Upper]. I propose therefore that for the feature [Upper], the universally supplied default rule is as in (51).

$$(51) \quad \textcircled{V} \rightarrow \begin{array}{c} V \\ | \\ [-\text{Upper}] \end{array}$$

As for [Raised], I will assume that the default value assigned by universal grammar is M, so the appropriate value for [Raised] is assigned by the rule in (52). The problem of how to derive a default L-tone for languages like Margi and Tiv will be returned to shortly.

$$(52) \quad \textcircled{V} \rightarrow \begin{array}{c} V \\ | \\ [+ \text{Raised}] \end{array}$$

The two default rules given in (51) and (52) combine to make M the unmarked tone. To derive the four tones shown in (50), the minimum underlying specifications required and the effect of filling in features by the default rules are illustrated in (53).

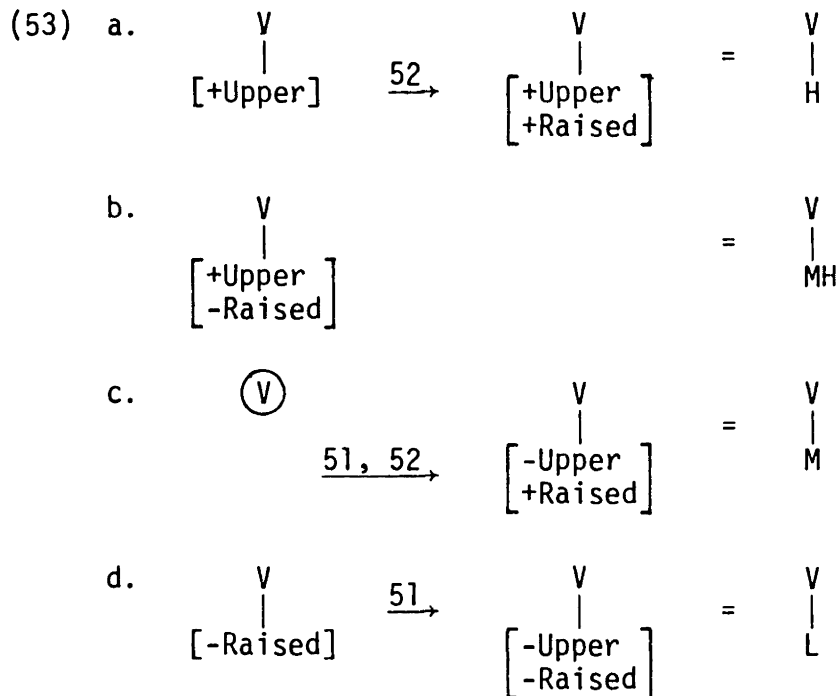

6. Binary vs. ternary features

With this much background, let me now address the problem of how to allow underspecification without ending up with a feature system that is actually ternary, not binary.

Kiparsky (1982) discusses a number of advantages inherent in a phonological theory that allows only 'marked' feature specifications to be entered into the lexicon. He was not the first to discuss such advantages (see for example Chomsky and Halle 1968), but since work by Lightner (1963) and Stanley (1967) it had generally been felt that the disadvantages of underspecification outweighed the advantages. In this section I will not review the various arguments for underspecified lexical entries -- for that the reader is referred to Kiparsky (1982). Some tonal arguments for underspecification have already been given in this chapter and others will be given in

chapters 4, 5 and 6. I will, however, discuss the major objection raised by Stanley and Lightner against underspecification as their objection is particularly relevant for analyses of some of the tonal systems examined in this thesis.

The basic argument against underspecification has been nicely summarized in Kiparsky (1982, p. 60-61):

(54) Lightner (1963) and Stanley (1967) argued that if you allow rules to apply to matrices containing unspecified features, then the standard notion of distinctness becomes incoherent and you end up in effect with a ternary feature system. Suppose that we have three segments A, B, and C, specified in the lexicon for the three features F_1 , F_2 , and F_3 as follows:

(2)		/A/	/B/	/C/
	F_1	+	0	-
	F_2	-	-	-
	F_3	-	-	-

In a binary feature system, two segments P and Q are distinct if they have opposite values + and - for some feature. This would make A and C distinct in (2) and B non-distinct from both. Yet, if rules are allowed to apply to the matrices in (2) they are inevitably capable of making all three mutually distinct. Suppose we have the rules

- (3) a. $[+F_1] \rightarrow [+F_2]$
 b. $[-F_1] \rightarrow [+F_3]$

If we assume the convention that [OF] is not analyzable as [+F] or as [-F], (3) applies to (2) to yield ¹⁸

(4)		/A/	/B/	/C/
	F ₁	+	0	-
	F ₂	+	-	-
	F ₃	-	-	+

and if we assume the convention that [OF] is analyzable as [+F] and as [-F], (3) applies to (2) to yield

(5)		/A/	/B/	/C/
	F ₁	+	0	-
	F ₂	+	+	-
	F ₃	-	+	+

In both (4) and (5), all three segments are technically distinct from each other. But we cannot allow rules to apply in such a way as to make nondistinct representations distinct. We then have to recognize "0" as a third feature value, so that B is distinct from A and C in (2). But this is unsatisfactory since we have no use for the extra feature value "0" in the operation of the phonological component. The theory in that form has expressive power which is not utilized in grammars, with resultant loss of explanatory adequacy.

Note that the problems raised by Lightner and Stanley apply equally well to autosegmental representations. Consider again the feature specifications given as (2) in the quotation from Kiparsky.

If F_1 was located on one tier, and F_2 and F_3 were represented on a different tier, then we could have a comparable autosegmental representation to (2) as follows:

$$(55) \quad \begin{array}{ccc} \begin{array}{c} [+F_1] \\ | \\ A \\ | \\ [-F_2] \\ [-F_3] \end{array} & \begin{array}{c} B \\ | \\ [-F_2] \\ [-F_3] \end{array} & \begin{array}{c} [-F_1] \\ | \\ C \\ | \\ [-F_2] \\ [-F_3] \end{array} \end{array}$$

Two autosegmental rules comparable to (3a) and (3b) are given in (56).

$$(56) \quad \begin{array}{l} \text{a.} \quad [-F_2] \rightarrow [+F_2] / \begin{array}{c} \text{---} \\ | \\ X \\ | \\ [+F_1] \end{array} \\ \text{b.} \quad [-F_3] \rightarrow [+F_3] / \begin{array}{c} \text{---} \\ | \\ X \\ | \\ [-F_1] \end{array} \end{array}$$

Assuming the normal autosegmental convention that a slot not linked to a feature F is not analyzable as $+F$ or as $-F$, (56) applies to (55) to give

$$(57) \quad \begin{array}{ccc} \begin{array}{c} [+F_1] \\ | \\ A \\ | \\ [+F_2] \\ [-F_3] \end{array} & \begin{array}{c} B \\ | \\ [-F_2] \\ [-F_3] \end{array} & \begin{array}{c} [-F_1] \\ | \\ C \\ | \\ [-F_2] \\ [+F_3] \end{array} \end{array}$$

Without belabouring the point, it should be evident from an examination of (57) that the shift to an autosegmental representation does not affect the argument against underspecification. Hence the issue of creating distinct representations from underlyingly non-distinct representations is independent of the type of representation, ie. segmental vs. autosegmental.

The crucial point to be examined with respect to the tonal analyses of this thesis is whether or not the expressive power of a ternary system is required. In examining this question, I will first show that a ternary system is not required for the tonal systems examined. Second, I will discuss the constraints required to prevent a ternary system from arising within a theory that employs underspecification.

6.1 Tone is not ternary

That a ternary distinction should arise in an area of the phonology that utilizes more than one feature is not surprising. For example, to find a vowel system that contrasts three heights of front vowels is hardly a matter for concern. We simply posit two features [High] and [Low] and specify the three vowels in the appropriate manner. Similarly for tone, when we observe a 'three-tone' language like Yoruba or a 'four-tone' language like Bete, we posit two tonal features and assign appropriate feature specifications. The problem arises when we encounter a language like Margi or

Tiv that requires three tonal possibilities for V-slots in the lexicon, but where two of the three possibilities are not distinguished phonetically.

Perhaps such cases constitute a ternary use of the feature $[\pm\text{Upper}]$. That is, H in Margi and Tiv would be represented as $[\text{+Upper}]$, L would be represented as $[\text{-Upper}]$ and the toneless vowels would be assigned $[\text{-Upper}]$ by default. The conclusion would then be that Lightner's and Stanley's criticisms of underspecification are to be disregarded not because there is a way to avoid the pitfalls they describe, but because the extra power of a ternary feature system is required. There are, however, several problems with such an approach. For example, it would predict that other features should exhibit the same ternary contrast observed in tonal systems. That is, if ternary power is required for tone, why not for other features? Such an approach would make the rather odd claim that a language like Tiv utilizes the feature $[\pm\text{Upper}]$ in a ternary fashion but does not use the feature $[\pm\text{Raised}]$ at all. And such an approach would predict the existence of languages accomplishing a six-way tonal contrast with two tone features, a six-way vowel height distinction with two features, etc.

Rather than conclude that phonological theory requires ternary power for distinctive features, I propose that the type of three-way tonal contrasts observed in languages like Tiv or Margi is accounted for by considering in more detail the notion of underspecification. In particular, it is important to consider why features

receive specifications. There are two obvious and important reasons. Feature specifications may be required in the formulation of the phonological rules of a language; feature specifications may be required for the phonetic implementation of a language. I would like to stress the use of the word 'may' in the preceding sentences. What requires specification of a given feature in any language is the phonetic and phonological facts of the particular language. For example, there is nothing about the phonology of English that requires specification of a feature like [\pm Suction] or [\pm Pressure] (Chomsky and Halle 1968 p.322-323). Even in the phonetics of English such features play no role. The most one can apparently say is that all sounds of English are produced without suction and without pressure. When a language does not even exhibit both values of a feature, it is extremely questionable that such a feature is actually represented in the grammar of an adult speaker of that language. For example, to consider some feature like [Pressure] as being active in speaker X's grammar of English, when speaker X is incapable of producing both + and - values of [Pressure] would seem to be trivializing the role of distinctive features in the sound system of a language like English.

With this much preamble, let me return to the question of tone. Consider the proposed lexical representation of the three tones of Yoruba.

$$\begin{aligned}
 (58) \quad H &= [+Upper] \\
 M &= \phi \\
 L &= [-Raised]
 \end{aligned}$$

When the default rules given above in (51) and (52) apply, the specifications of (58) will be filled out to

$$\begin{aligned}
 (59) \quad H &= \begin{bmatrix} +Upper \\ +Raised \end{bmatrix} \\
 M &= \begin{bmatrix} -Upper \\ +Raised \end{bmatrix} \\
 L &= \begin{bmatrix} -Upper \\ -Raised \end{bmatrix}
 \end{aligned}$$

This correctly predicts the H, M, L contrast attested on the surface.

Consider now what happens if only the default rule (51) applied, that is, only the rule that assigns [-Upper].

$$\begin{aligned}
 (60) \quad H &= [+Upper] \\
 M &= [-Upper] \\
 L &= \begin{bmatrix} -Upper \\ -Raised \end{bmatrix}
 \end{aligned}$$

The interesting point about such an assignment is that in (60), H is distinct from both M and L, while M and L are non-distinct with respect to each other. This is of course precisely the result that we are aiming to achieve for Margi and Tiv. So the only real question therefore is the following: Can we assume that H and L in a language

like Tiv are represented as in (58) and that only the default rule assigning [-Upper] applies in such a language?

As for representing H and L as [+Upper] and [-Raised] respectively, this is required if we wish to maintain binary features. Moreover, since both features are clearly motivated there is no obvious reason not to assume such a representation.

Can we therefore assume that a default value only for the feature [Upper] is assigned? Again, there is no obvious reason for not making such an assumption. There are clearly languages that only require a single tone feature in their phonological and phonetic components -- a few examples will be seen in chapter 4. As is the case with features such as [Suction] and [Pressure] in English, [Raised] plays no role in languages like Tonga and Japanese, as we will see in chapter 4. In those languages, pitch registers are not broken down into sub-registers either at the phonological level or at the phonetic level. Hence it would seem that there is no universal requirement to specify segments for the feature [Raised]. And the phonological and phonetic facts of languages like Margi and Tiv argue for not requiring the specification of the unmarked value of [Raised].

Two questions are appropriate. Would the above proposal allow a language where neither [Upper] nor [Raised] were assigned default values? And could a language assign the default value of [Raised] but not assign the default value of [Upper], where such assignment would produce the result illustrated in (61)?

- (61)
- | | | |
|---|---|---------------------|
| H | = | [+Upper
+Raised] |
| M | = | [+Raised] |
| L | = | [-Raised] |

The answer to both questions is no. If no default value were assigned then the toneless vowels would remain toneless. But all vowels require some tonal specification in such languages. Hence toneless vowels would be phonetically uninterpretable if no tonal feature were assigned to them. One might assume that random pitch values would be assigned to vowels unspecified for tone. But such a proposal would simply derive the wrong results, since the toneless vowels in Tiv and Margi are not produced on any random pitch. Hence phonetic facts of Tiv and Margi would require that a tonal value be assigned.

In Tiv and Margi, the appropriate value is [-Upper]. But could we then have a language that would only assign [+Raised] as a default value, producing a configuration as in (61) where the underlyingly toneless vowels (ie. M) were realized as non-distinct from H? Again the answer is no, because a representation like [+Raised] or [-Raised] is uninterpretable phonetically. One cannot assign a vowel to the top or bottom of a sub-register if the vowel has not been assigned to a register. That is, one cannot make fine distinctions in pitch without first making a gross distinction. Hence by virtue of the hierarchical organization of the features [Upper] and [Raised], if only one feature is assigned it must be [Upper]. 19

To conclude, I have argued in this section that the three-way underlying contrasts that are observed in certain languages that have only a H, L tonal distinction arise not from the ternary use of a single phonological feature but from the utilization of two tone features. Two tone features are independently required in any event to account for languages with three or four contrastive tones that all surface as distinct. In the above account, tone is only viewed as distinct from other features in terms of its hierarchical representation -- a position for which Clements (1980) and Yip (1980) have presented considerable evidence. By assuming that distinctive features are only assigned values when there is positive evidence for such specifications, we arrive at the above logical possibility. Both tonal features [Upper] and [Raised] are required by the phonological facts of Tiv and Margi -- but only [Upper] is required to account for the phonetic implementation of tones in these languages.

6.2 Constraints on underspecification

Up until now, I have shown that there are reasons for wanting certain tones to be underspecified underlyingly. I have also shown that cases of underspecification such as observed in Margi and Tiv do not require that a single tone feature be used in a ternary way. The question left to be addressed is whether in spite of trying to maintain a binary system, I have in fact through the use of underspecification derived a ternary system.

6.2.1 Referring to unmarked values

First of all, one point concerning the operation of default rules needs to be clarified. As long as all default rules applied in the lexicon, one could assume that default rules apply to all core slots and that the fact that they only fill in features but do not change features is a result of the Elsewhere Condition. By construing lexical entries as rules (Kiparsky 1982) then the lexical linking of a H-tone to V_i would prevent a default rule from assigning a M-tone to V_i since the more specific rule (in this case, the lexical entry itself) would block the application of the more general rule (in this case, the rule of Default M-insertion). But we have seen in a language like Yoruba that it is possible for Default M-insertion to apply post-lexically and not lexically. Hence the Elsewhere Condition could not prevent a rule of the form given in (62) from applying across-the-board to wipe out all lexical tones -- it could not prevent it because rules applying in different components (in this case, the lexical entry 'rule' applying lexically and the rule of Default M-insertion applying post-lexically) do not apply disjunctively.

$$(62) \quad V \quad \rightarrow \quad \begin{array}{c} V \\ | \\ M \end{array}$$

In order to prevent such a wiping out of tones by the default rule, we must constrain the application of rules such as (62). The approach that I will adopt is to recognize formally the distinction

between linked and free core slots, restricting the application of default rules to free core slots. Hence (62) would be reformulated as (63). (Actually (63) is shorthand for the two rules (51) and (52))

$$(63) \quad \textcircled{V} \rightarrow \begin{array}{c} V \\ | \\ M \end{array}$$

Other rules must have access to this distinction as well. For example, tone spreading rules commonly spread tones onto free V-slots but not onto a V-slot already linked to a tone. See for example rules (20) and (25) given in chapter 4 for Luganda and Tonga. Also, in chapter 6 I give an example where a rule of floating tone deletion in Tiv appears to be sensitive to the existence of a free core position.

I assume, however, that the core is special in this respect. That is, while a rule may refer to a free core position, it cannot refer to [OF]. By examining a core slot, one can determine whether or not such a slot is linked to a value for feature F; such linking, or lack thereof, can be referred to by rules. But if a feature has not been specified on some tier, then it simply does not exist. For example, if a word is completely toneless, then there is no tone present for some tonal rule to apply to. Hence a rule such as (64) is impossible.

$$(63) \quad [+F] \rightarrow [+G] / \text{---} [OF]$$

As a final point, the notion of free core slot is a relative one. A slot is 'free' for feature G if not linked to a value for feature G; it may of course be linked to some other feature.

6.2.2 Constraints

Kiparsky (1982) proposes that for any particular environment only the marked value of a feature may be specified. Hence for any environment Q, there is only a binary contrast possible underlyingly: $[\alpha F]$ or ϕ . Note that markedness must be contextually defined since marked and unmarked values differ in different contexts. For example, the unmarked value for [Round] is [+Round] for non-low back vowels while it is [-Round] for other vowels; the unmarked value for [Voice] in English obstruents is [+Voice] immediately before a voiced obstruent but [-Voice] elsewhere. See Kiparsky (1982).

But such contextually defined markedness creates a problem. Consider the following rules:

- (64) a.
- $$\textcircled{X} \rightarrow \begin{array}{c} X \\ | \\ [+F] \end{array} / \text{---} \begin{array}{c} P \\ | \\ X \end{array}$$
- b.
- $$\textcircled{X} \rightarrow \begin{array}{c} X \\ | \\ [-F] \end{array} / \text{---} \begin{array}{c} R \\ | \\ X \end{array}$$

The unmarked value for [F] is + in environment P, but - in environment R. This means that [-F] is an acceptable marked feature specification for [F] in certain underlying environments while [+F] is an acceptable specification in other environments. Hence if rules can refer to a core slot that is linked to [+F], a core slot that is linked to [-F], and also to core slots that are unspecified with respect to [F], then we have derived a ternary system.

To solve this problem we need a constraint on rule application.
Consider (65):

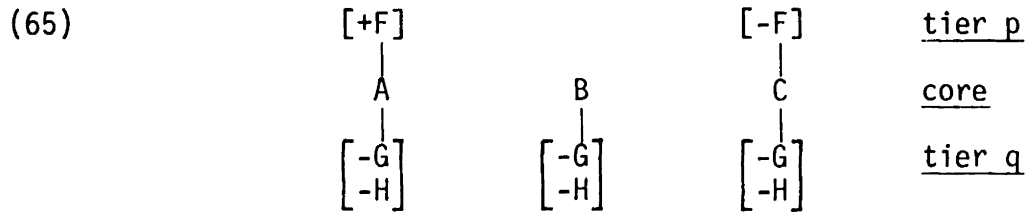

Let us assume that the minimal default rule for [F] is (66).

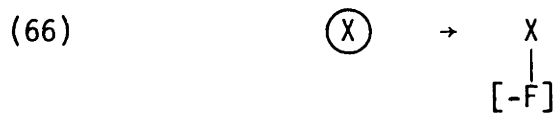

Given a situation such as represented in (65) and (66), there is evidence that we must allow a rule to spread [+F] prior to the default assignment of [-F] by rule (66). Such cases will be discussed for Luganda and Tonga in chapter 4, where the feature 'F' in such cases is [Upper].

It would seem therefore that whatever the appropriate constraint on rule application is, it must allow (67).

(67) A rule must be able to refer to [-αF] in its structural description prior to default assignment of [αF].

Let us now assume that in the representation in (65) all values of [G] and [H] have been assigned. This is to eliminate any possible problem about having feature changing rules involving [G] and [H]. Given this assumption, a rule like (68) should be well-formed.

$$(68) \quad [-G] \rightarrow [+G] \ / \ \begin{array}{c} \text{---} \\ | \\ X \\ | \\ [+F] \end{array}$$

Allowing rules like (68) does not in itself create any problem. But if either of the rules in (69) is possible, in addition to the rule in (68), then it will be possible to create distinct representations from underlyingly non-distinct ones.

$$(69) \text{ a.} \quad [-H] \rightarrow [+H] \ / \ \begin{array}{c} \text{---} \\ | \\ X \\ | \\ [-F] \end{array}$$

$$\text{b.} \quad [-H] \rightarrow [+H] \ / \ \begin{array}{c} \text{---} \\ | \\ X \end{array} \text{ , where } X \text{ is free with}$$

respect to [F].

An appropriate constraint on rule application must therefore block both (69a) and (69b):

- (70) a. A rule must not refer to $[\alpha F]$ in its structural description before a default rule assigns $[\alpha F]$.²⁰
- b. A rule must not refer to the fact that a slot is not linked to a value on tier n for purposes of affecting a feature value on tier m.

The constraint in (70a) will block a rule like (69a) from applying until after application of the default rule (66). Of course, once the

default rule has applied, there is no problem in allowing (69a) to apply since the phonological string on which (69a) will be operating will be completely specified. Concerning (69b), such a rule will be completely ruled out by (70b).

Note, however, that (70b) can be derived as a sub-case of (70a). To know whether a given X is free with respect to $[F]$, one must refer to both + and - values of F . There can only be free X -slots if the default rule assigning $[\alpha F]$ has not applied. By (70a), to refer to the value α of F , the default rule assigning α must have applied. Hence we are led to a contradiction: To refer to a free X -slot -- as opposed to an X -slot linked to $[\alpha F]$ -- one must be able to refer to $[\alpha F]$, the default value; but by (70a), to be able to refer to $[\alpha F]$, the default rule assigning $[\alpha F]$ must have applied, hence there can be no free slots to refer to. Hence given (70a), we do not need to stipulate (70b).

By the above argument, if a rule refers both to a free core slot and to a marked feature specification, then the reference to the core can only mean 'free with respect to a marked feature specification'. Hence a rule like (71), where $[-\alpha F]$ represents the marked value, should apply both to (72a) and to (72b) if because of context-sensitive redundancy rules both $[\alpha F]$ and $[-\alpha F]$ were possible underlying specifications.

(71)

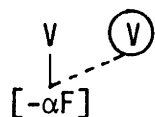

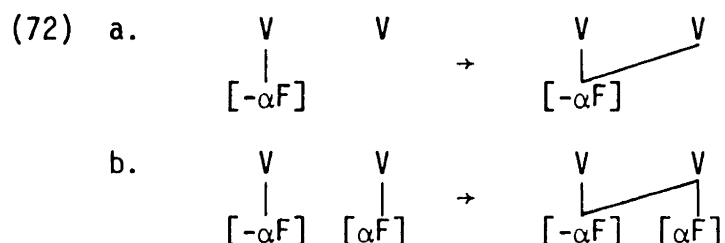

All the relevant cases examined in this thesis are of the type shown in (72a). Consequently, whether this prediction is correct will have to be left for further investigation.

The effect of the constraint given in (70a) is to impose an ordering strategy for rules that assign default feature specifications. Archangeli (in preparation) suggests that if some default rule Y applies in the grammar of language X , then it will apply as late in the grammar as possible. This suggestion will be considered in more detail in chapter 6. For the present, it is sufficient that if such a principle is combined with a constraint such as (70a), then all default rules will be ordered immediately before any rule that refers to the default value in its structural description. The effect of this ordering is that a binary feature system is preserved. A rule may refer to a marked feature value or the absence of such a marked feature value up until the point where default specifications take place. When default values have been supplied, rules may refer to the + and - values present in the string at that point. So both before and after assignment of default specifications, the possibilities for what rules may refer to are binary.

Note that the constraint in (70a) imposes certain ordering

restrictions even on language specific rules. While a language specific default rule is presumably subject to extrinsic ordering, by (70a) it could not be ordered after a rule referring to the feature value that it assigns. As for the relative ordering of default rules, I assume that they are subject to the Elsewhere Condition. Comparing rules such as (66) and (71), for example, if α was + in (71), then (71) would have to apply before (66) since it is the special rule -- that is, the structural description of (71) properly includes the structural description of (66).

6.3 Default L vs. default M

The last question that I will briefly address in this chapter is whether it is possible to predict whether a default tone will be L or M, that is can one predict whether default rules for both [Upper] and [Raised] will apply in a given language, or whether only the default rule for [Upper] will apply?

A possible correlation with this choice concerns the utilization of lexical linking. In Margi and Tiv, we will see in chapters 5 and 6 that there is a loss of generalization if tones are lexically linked to vowels. An analysis is required where tones are underlyingly unlinked and undergo association by convention. Hence apart from a few exceptions, tone-bearing units in Tiv and Margi are uniformly free in underlying representations.

In Yoruba, on the other hand, to require that tones be underlyingly unlinked introduces complications into the grammar. For example, one does not observe tonal melodies in Yoruba with more tones than

there are tone-bearing units in the word. This observation is accounted for straightforwardly by a one-to-one constraint on the number of tones that can be linked underlyingly to a single tone-bearing unit -- if tones are underlyingly linked. More serious is the distribution of M-tones in polysyllabic words. Consider examples like the following:

- | | | |
|---------|--------|-----------------|
| (73) a. | īlé | 'house' |
| b. | ōbẹ̀ | 'soup' |
| c. | àlāpà | 'type of food' |
| d. | tíótó | 'Grey Hornbill' |
| e. | ìgbōlé | 'type of plant' |

Since M-tones are underlyingly unspecified in Yoruba, none of the above tonal patterns can be accounted for by the use of unassociated lexical tone melodies. Hence in underlying lexical entries in Yoruba one is required to link H and L tones in order to derive the correct surface location of M-tones in words such as those in (73). This means that underlyingly in Yoruba, a tone-bearing unit may be linked to a H ([+Upper]), to a L ([-Raised]), or to nothing.

Hence the three-way tonal distinction for V-slots is present underlyingly in Yoruba, while in Tiv and Margi it is derived by the association conventions. Whether this difference actually correlates with the default L vs. default M distinction -- and if so, why -- will be left for further research.

7. Conclusion

In this chapter, I have examined certain tonal phenomena that require underspecification of features. The feature composition of tonal autosegments has been discussed and it has been proposed that the default value for 'Register' is [-Upper], while the default value for the feature that sub-divides registers is [+Raised]. The analyses provide strong support for a set of association conventions that link tones to tone-bearing units in a strict one-to-one fashion. Default tones have been argued to be autosegmental in nature and it has been shown that such autosegments may be assigned post-lexically. The problem of ternary use of binary features has been examined, with the conclusion that, as far as the languages that have been examined in this thesis are concerned, tone does not require ternary power.

FOOTNOTES: CHAPTER 3

1. Margi will be discussed in some detail in chapter 5.
2. For some discussion, see chapters 1 and 6.
3. See Kiparsky (1982).
4. H-tone stems behave somewhat differently since the H itself is reduplicated, and a downstep appears between the reduplicated portion and the verb stem: òjé!jé 'knowing', òré!ré 'eating'.
5. See Akinlabi (in preparation) for further discussion.
6. These examples are from Awobuluyi (1977). In Yoruba orthography, $\text{ɕ} = \text{ʃ}$, $\text{ɔ} = \text{ɔ}$, $\text{ɛ} = \text{ɛ}$, $\text{p} = \text{kp}$, $\text{Vn} = \tilde{\text{V}}$.
7. See, for example, Bamgboṣe (1964, 1965), Oyelaran (1971), Badejo (1979).
8. Examples are from Ward (1952), Bamgboṣe (1966) and Akin Akinlabi (personal communication).
9. This rule is an autosegmental formulation of a rule that has been acknowledged since the early writers on Yoruba tone. Ward (1952), for example, notes that a "low followed by high requires a glide up to the high tone". It is somewhat unclear whether this rule should be a phonological rule or a phonetic rule. While this is an interesting question, I will not address it here.
10. Note moreover that rising contours are not restricted to word-

final position:

apoti	→	$\begin{array}{c} \grave{\text{a}}\text{p}\acute{\text{o}}\text{t}\acute{\text{i}} \\ \diagdown \quad \diagup \\ \text{L} \quad \text{H} \quad \text{H} \end{array}$	→	'box'		
$\begin{array}{c} \quad \quad \\ \text{L} \quad \text{H} \quad \text{H} \end{array}$						
aronkṓn	→	$\begin{array}{c} \text{a}\text{r}\acute{\text{o}}\text{n}\text{k}\acute{\text{o}}\text{n} \\ \diagdown \quad \diagup \\ \text{L} \quad \text{H} \end{array}$	→	$\begin{array}{c} \text{a}\text{r}\acute{\text{o}}\text{n}\text{k}\acute{\text{o}}\text{n} \\ \diagdown \quad \diagup \quad \\ \text{L} \quad \text{H} \quad \text{M} \end{array}$	→	'obstinacy'
$\begin{array}{c} \quad \\ \text{L} \quad \text{H} \end{array}$						

11. There are a number of facts, both phonological and phonetic, that bear on this issue, but such facts will not be discussed here.
12. Bamgboṣe notes in a footnote that the fall/lack of fall contrast may be a dialectal difference. Akinlabi (in preparation) supports this idea, suggesting that in Standard Yoruba there is no fall in such cases, while in certain dialects there is systematically a fall.
13. The low may be realized as a fall (although not as sharp) even in (33) because of a phonetic rule that downglides final L-tones in Yoruba regardless of the preceding tone. See Hombert (1974) and La Velle (1974).
14. This possibility was suggested to me by Morris Halle and is being explored by Akinlabi (in preparation).
15. This suggestion was made to me by Paul Kiparsky.
16. Akinlabi assumes that the H-tone is a subject marker introduced within the verb phrase, whereas I assume that it is introduced in the inflectional constituent that precedes the verb phrase. This point is, however, irrelevant to the issue being discussed in this thesis.
17. The precise way this works will be discussed in chapter 5.
18. In (4), I have corrected what I assume to be typographical errors in Kiparsky (1982). (In Kiparsky (1982), (4) is identical to (5))
19. Both Clements (1980) and Yip (1980) assumed that in certain languages tones could be assigned by virtue of a single tonal feature. In Clements' system, it followed automatically that if only one 'feature' was assigned then it would be the equivalent to the [\pm Upper] distinction. Moreover, Clements allowed a language to divide one

register into sub-registers without sub-dividing the other register. But if the proposal of this thesis is correct that the two tone features are assigned different default values, then this constitutes a strong argument for Yip's proposal analysing the tonal hierarchy as being composed of two features -- not as multiple assignments of a single feature.

20. This proposal is made in Archangeli (in preparation). Note also Chomsky and Halle (1968 p. 384). Note that this constraint must be relative to the set of P-bearing units defined for the feature in question. That is, if tones are lexically assigned only to [+syllabic] segments, then default rules need only apply to [+syllabic] segments in order to satisfy (70a). That is, (70a) should be reformulated as:

A rule must not refer to [α F] in its structural description before a default rule assigns [α F] to all [F]-bearing units.

The P-bearing units for some language might differ lexically and post-lexically. It would be possible, therefore, for a rule to apply lexically and make reference to [α F], if the default rule had applied lexically to assign a value of [α F] to all lexically-defined [F]-bearing units. Post-lexically, if the class of [F]-bearing units was enlarged, then certain post-lexical [F]-bearing units might still be unspecified for [F], in spite of lexical application of the default rules.

The relevance of the notion of 'P-bearing' unit for default

rules was pointed out to me by Paul Kiparsky. He suggests that the case described above -- where lexical and post-lexical definitions of P-bearing units differ -- holds for Russian voicing assimilation.

Rules in this approach are of two types: 1) accentual rules 2) tone rules. Accentual rules move, delete and insert accentual diacritics; they apply before and potentially also after the assignment of tones. Tone rules in this approach must, of course, follow assignment of tonal melodies, and they may, in principle, refer to accentual properties of words. The last approach is that proposed for 'stress' systems. In stress languages, tones are introduced at a relatively late stage (if at all). Underlying representations may or may not include diacritic markings utilized in the construction of metrical trees or grids. Grids or trees are constructed, and tones are introduced during the interpretation of such metrical structures.

In this chapter, I will argue that the second of these three approaches should be abandoned. It will be argued that the properties that such languages exhibit do not justify the introduction into tonal theory of accentual diacritics. The types of phenomena that motivated such diacritics will be accounted for by independently motivated devices available within non-accentual tonal theory.

1. Diacritics

With regard to stress, it has been shown (eg. Hayes 1980) that syllable weight plays an important role in triggering the construction of metrical trees or grids. It has also been shown, however, that a representation of syllable structure alone is insufficient for the determination of stress. For example, Hayes (1980) shows that certain 'light' syllables in Aklan function with regard to stress assignment as though they were 'heavy'. He proposes that such syllables be

diacritically marked to trigger the same metrical rules triggered in a regular fashion by heavy syllables. The question for tonal accent systems is the following: Can we consider the evidence for diacritics in stress systems as motivation for the introduction of diacritics into tone systems? The answer to this question would appear to be no.

In a stress language, prominence relations are read off of metrical trees or grids.¹ Such metrical structure is created by general rules that determine types of feet, direction of foot assignment, etc. In many cases, the class of elements that trigger the creation of a new foot is completely predictable from their phonological make-up. For example, heavy syllables often trigger the creation of new feet. But in some cases, foot construction is not completely predictable. Diacritics have therefore been introduced with one specific object in mind -- to trigger the creation of a foot. Hence the property of an accentual diacritic is essentially that it marks a syllable as a 'head'; consequently, such a syllable cannot be dominated by a recessive metrical node, and the general rules of foot assignment will start a new foot at that point.²

This 'head-marking' function of diacritics in stress systems is not related in any obvious way to the use of diacritics in cases like (1) above. In (1), the diacritics do not trigger formation of any type of metrical structure. They determine the alignment of tones to core slots, since the linkings in cases like (1) are clearly not by left-to-right association conventions.

Several points are interesting in this regard. First, in stress

Such cases can be ruled out by some convention in an accentual approach but are inherently impossible if only using pre-linking. Similarly, an accentual approach to exceptional linkings allows the possibility of referring to accent in a language's tone rules. This additional power is unavailable if exceptional linkings are established by pre-linking.

To conclude this section, it would seem that the use of diacritic accents should be avoided unless it can be demonstrated that less powerful devices such as pre-linking are not sufficient to account for cases of unpredictably located tonal linkings.

2. Pre-linking

In this chapter, I argue that analyses of 'accentual' languages like Luganda and Tonga are possible by assuming pre-linking of tones as the indicator of 'accent'. In this section, I will briefly point out why this approach was problematic in earlier autosegmental accounts.

Consider the representation of a noun like àbàpákàsì 'porters' in Luganda. In order to derive the tonal form of this noun, we need a single piece of information, namely that the syllable pa is marked in some way. Let us assume that this marking is accomplished by pre-linking pa to a H-tone (Hyman 1982 b).

$$(3) \quad \left[a \left[ba \left[\begin{array}{c} \text{pakas} \\ | \\ \text{H} \end{array} \right] i \right] \right]^3$$

If we follow the proposal of chapter 3, and assume that H is in fact an assignment of [+Upper], then the default rule assigning [-Upper] will correctly assign L-tones to all syllables except pa in (3).

In an autosegmental theory that assumes automatic spreading, however, the representation in (3) would result in a * H H H H H sequence. Consequently, because of the assumption of automatic spreading, one would be forced to introduce L-tones on both sides of the H in (3). But it turns out that the introduction of such L-tones results in complications in the analysis of Luganda. Hence one was forced to look for some alternative way of indicating the special status of the syllables like pa, and a theory of accents was proposed.

In chapter 3, we saw that tones do not spread automatically in Yala and Yoruba, and additional evidence against automatic spreading will be presented in chapters 5 and 6. Hence given the theory of association conventions assumed in this thesis, there is no obvious reason for not representing 'accent' in languages like Luganda simply by the pre-linking of a H-tone.

3. 'Culminative' function

Typically in stress languages, there will only be one primary accent per accentual unit (NB.: Hyman 1978 and references there). In a metrical approach this follows from the representation. If feet are brought together into a word tree (Hayes 1980), then there will be a single node defined by the word tree as prosodic 'head' of the word. Hence a metrical approach correctly predicts this 'culminative'

property to be typical of stress systems. It also follows that the relative prominence of the heads of feet will be different, depending on their position in the word tree. Hence a metrical approach predicts 'accent subordination'.

In the accent-diacritic approach to tonal phenomena such as in (1) above for Tonga, however, there is no formal reason to expect a single 'accent' per accentual unit. Moreover, cases of more than one 'accent' are attested in some such languages -- we have already seen one example with tòmbélà 'lizard' (1).

Nevertheless, there do appear to be languages where a single tonal 'accent' is possible per 'accentual' unit. Do such cases constitute an argument for accent-diacritics and against pre-linking? The answer is no. In an analysis that assumes diacritics, but does not assume metrical structure, there is no reason for assuming 'one diacritic per accentual unit'. Hence the grammar must include a stipulation to that effect. Such stipulations are not uncommon in non-accentual 'tone' languages. For example, we saw in chapter 3 that Yoruba stipulates a maximum of one tone per tone-bearing unit underlyingly. And we will see in chapter 6 that Tiv stipulates one tone per verb. Hence discovery of limitations on the number of 'accents' or 'tones' that can be assigned to some prosodic unit, does not constitute an argument for an 'accentual' analysis.

Concerning accent subordination, it has been found that the tonal-accent languages like Tonga do not manifest this property. Again, therefore, we find a lack of evidence for a true accentual approach.

Both of these facts -- ie., multiple accents per word and lack of subordination -- have been pointed out by Goldsmith (1981). But, unlike Goldsmith, I interpret them as arguments against introducing the notion of 'accent' into the analysis of such languages.

4. Distributional constraints

Another argument for a language being 'accentual' as opposed to 'tonal' concerns the number of possible prosodic patterns for prosodic units of length n (NB.: Hyman 1978). In a tone language, if there were two tones, then one would expect 2^n possibilities for words of length n , while a languages with three tones would be expected to exhibit 3^n possibilities for words of length n . An accentual language, on the other hand, would be expected to exhibit n possibilities for a word of length n , or $n+1$ possibilities if words can be underlyingly accentless.

As Hyman points out, however, languages are rarely so straightforward. For example, Yoruba restricts the occurrence of tones on the first syllable of a disyllabic noun to M and L, although the second syllable can bear H, M or L. Hence for Yoruba, a three-tone language, disyllabic nouns have only six possible prosodic patterns. And as mentioned above, Tiv allows only a single tone per verb; hence, even for trisyllabic verbs, there are only two prosodic patterns.

On the other side of the coin, it has been proposed that accents in languages like Fasu (May and Loeweke 1964) and Igbo (Clark 1982), may be assigned more than one possible tonal melody, thereby multiplying the number of possible prosodic patterns in such an

'accent' system.

Consider a hypothetical language that exhibits two surface tones, H and L, and where the patterns L L, L H and H L are possible on disyllabic nouns, but not * H H. This distribution could be accounted for accentually by assuming that the three possible patterns are : V V, V ^{*}V and ^{*}V V, and that no word may bear two accents. The same distribution could be accounted for tonally, if we assume that the possible patterns are represented as: V V, V $\begin{array}{c} | \\ H \end{array}$ and V $\begin{array}{c} | \\ H \end{array}$ V ; L-tones are

assigned by default and no word may bear two lexical tones.

Hence one cannot conclude that a given language requires the notion 'accent' by determining the number of prosodic patterns for words of length n.

5. Melodies

One argument that has been advanced for analysing languages like Tonga as accentual is that the tonal representation "consists strictly of an integral number of copies of a fixed language-specific Basic Tone Melody" (Goldsmith 1982). For example in Tonga, Goldsmith (1981) and Halle and Vergnaud (1982) propose that the Basic Tone Melody is H ^{*}L. To the extent that such generalizations are valid -- since even in an accentual approach, such patterns can be masked by the operation of phonological rules -- I suggest that the relevant tonal 'melodies' are simply the result of applying rules and conventions to underlying representations that include pre-linked tones.

For example, in the Luganda example seen in (3), what might be construed as a $L \overset{\star}{H} L$ accentual melody is derived by the interaction of a pre-linked H-tone with the rule of default L-insertion discussed in chapter 3 (sections 5. and 6.1).

By proposing that such melodies are derived rather than basic, this approach can re-instate a constraint that has surreptitiously been by-passed by the melody approach. In Chomsky and Halle (1968), it is proposed that phonological rules of the type shown in (4) should be disallowed in the construction of grammars.

$$(4) \quad A \rightarrow B C \quad / \quad P \quad \underline{\quad} \quad Q$$

But the rules assigning tonal melodies are rules of precisely this sort. The structural description of tone melody assignment is an accented unit, and the structural change consists of assigning a sequence of tones to such a unit:

$$(5) \quad \overset{\star}{V} \rightarrow \begin{array}{c} \overset{\star}{V} \\ | \\ H \overset{\star}{L} \end{array}$$

Hence such rules should only be allowed in a grammar if it can be demonstrated that the tonal sequence constitutes some type of single unit. Such is, of course, the claim of the tonal accent approach, but there is, as far as I can tell, no evidence for such a claim.

Sequences of tones can constitute a unit. For example, one or more tones may constitute all (or part) of a morpheme in some language. But the relevant sequences of tones in a language like Tonga do not

constitute morphemes. One such sequence is assigned to every occurrence of an accent, irrespective of the morphological make-up of the relevant unit (NB.: figure (1) above).

To allow assignment of sequences of tones to a single element because such sequences constitute some sort of 'tonal melody' opens up the possibility of all manner of rules that would violate the condition prohibiting rules of the type shown in (4). For example, epenthesis rules could insert 'core melodies' as in (6).

$$(6) \quad \phi \rightarrow [VC / C _ V]$$

They could also insert 'harmony melodies' as in (7).

$$(7) \quad \overset{*}{C} \rightarrow \begin{array}{c} \overset{*}{C} \\ | \\ [+back] [-back] [+back] \end{array}$$

Without imposing severe constraints on the types of sequences that can legitimately constitute 'prosodic melodies', such a move results in a considerable weakening of phonological theory.

'Melodies' of the types shown in (8) can be derived by pre-linking a tone and assigning a second tone by a rule of epenthesis (assuming that default rules, etc. would not have derived the melody without special epenthesis rules).

$$(8) \quad \begin{array}{ll} \text{a.} & [\alpha \overset{*}{F}] \\ \text{b.} & [\beta F] [\alpha \overset{*}{F}] \end{array}$$

- c. $[\alpha^*F] [\beta F]$
 d. $[\beta F] [\alpha^*F] [\gamma F]$

For example, the pattern in (8c) could be derived by the rule in (9), where $[\alpha F]$ represents the pre-linked value.

$$(9) \quad \phi \rightarrow [\beta F] / [\alpha F] \text{ ___}$$

On the other hand, melodies like those in (10) could not be derived by any single rule of epenthesis, unless such a rule was of the prohibited type shown in (4).

- (10) a. $[\alpha^*F] [\beta F] [\gamma F] \dots$
 b. $\dots [\beta F] [\gamma F] [\alpha^*F]$
 c. $\dots [\beta F] [\gamma F] [\alpha^*F] [\beta F] [\psi F] \dots$

By assuming that complex melodies must be derived by rules, we predict that the melodies of (10) will be highly marked, compared to those in (8), since the melodies in (10) would require more than one rule in their derivation. And from the cases discussed in work by Goldsmith (1981, 1982), Clark (1982), Haile and Vergnaud (1982), Odden (1982), etc., this prediction seems to be correct, as there have been no melodies proposed in such work that would correspond to the cases in (10). Hence even if it becomes necessary to have tonal melodies in the grammar of some language, a restrictive theory should require that such melodies be derived by rules of epenthesis, rather than to allow them to appear cost-free as some

type of 'melodic unit'.

6. Symmetry

As a final point, Hyman (1978) suggests that in 'tone' languages, tones behave in a relatively symmetric fashion, whereas in 'accent' languages, one tone (generally the H-tone) has some special status. There are two points to be made about this suggestion. First, this thesis suggests that even in 'tone' languages like Yoruba, Tiv and Margi, one observes asymmetrical behaviour of different tones. Hence in Yoruba, H and L tones have a special status with respect to M; in Tiv, as I will show in chapter 6, the status of L-tones is different from that of H-tones. While this asymmetry is not fully explained in the present account, a partial explanation is supplied by the theory of underspecification. In Yoruba, for example, we saw that H and L tones were 'special' in that they are underlyingly represented -- unlike M-tones that are only assigned by default.

Underspecification also contributes to an explanation of the special status of the H-tone in 'accent' languages like Luganda and Japanese. It is proposed that such languages have been thought of as 'accentual' because only H-tones are represented underlyingly -- that is, vowels are underlyingly either linked to a H-tone or toneless. It follows that rules of spreading, etc. will treat H-tones differently from L-tones since rules affecting H-tones may apply prior to the assignment of L-tones, while rules affecting L-tones apply to a fully specified string.

7. Luganda

The proposal to represent tonal accents as lexically linked tones comes from work on Luganda by Hyman (1982). Hyman proposes that an 'accented' vowel in Luganda should be represented underlyingly as in (11).

$$(11) \quad \begin{array}{c} \text{V} \\ | \\ \text{H} \end{array}$$

As we saw in (3) above, this means that a noun like àbàpákàsì 'porters' will be represented as in (12).

$$(12) \text{ a. } \left[\text{a} \left[\text{ba} \left[\begin{array}{c} \text{pakas} \\ | \\ \text{H} \end{array} \right] \text{i} \right] \right]$$

Although Hyman assumed two separate mechanisms for assigning L-tones to a word like (12), I will assume here that their source is uniformly Default L-insertion.

$$\text{b. } \begin{array}{ccccccc} \text{a} & + & \text{ba} & + & \text{pakas} & + & \text{i} \\ | & & | & & | & | & | \\ \text{L} & & \text{L} & & \text{H} & \text{L} & \text{L} \end{array}$$

A crucial fact to be captured in an analysis of Luganda is that there are precisely two tonal/accental options available for underlying vowels. Hence the H in (11) refers in fact to a specification of [+Upper], as the feature [Raised] plays no role in Luganda. Similarly, the rule of Default L-insertion refers to the assignment of the default value for [Upper]:

(13) Default L-insertion: $\textcircled{V} \rightarrow \begin{array}{c} \check{V} \\ | \\ [-\text{Upper}] \end{array}$

Underlyingly, vowels may either be toneless or they may bear a H-tone.

Evidence that the vowels that surface as L in cases like (12) are really toneless, comes from consideration of phrases like:

àbàtālìlàbìlìlā ábápákàsì 'they who will not look after porters'.

According to Hyman, this phrase has the underlying representation given in (14).

(14) a + ba + ta + li + lab + il + il + a ## a + ba + pakas + i
 | | | | |
 H H H H H

Two rules are relevant for the derivation of the surface form of this phrase. First, a rule is required to change the second H into a L

in a V V sequence:

 | |
 H H

(15) Lowering: ⁴
 H → L / $\begin{array}{c} V \\ | \\ H \end{array}$ $\begin{array}{c} V \\ | \\ \text{---} \end{array}$

This rule must apply iteratively from right to left in order to derive (16) from (14).

(16) a + ba + ta + li + lab + i! + il + a ## a + ba + pakas + i
 | | | | |
 H L L L H

The second rule that is relevant spreads a H-tone onto any toneless

vowels to its left, provided that the sequence of toneless vowels is preceded by a vowel to which a tone is assigned.

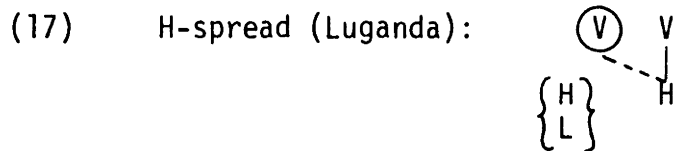

This rule, like Lowering, applies iteratively from right to left, deriving (18) from (16).

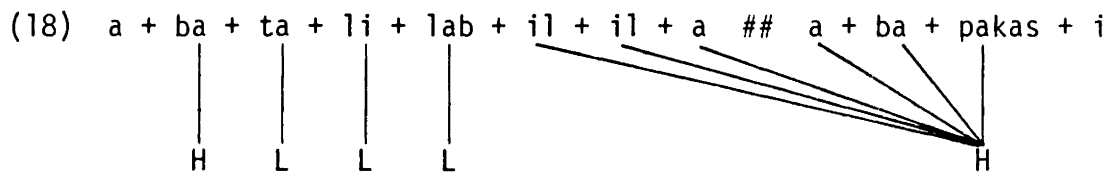

And as the final stage of the derivation, Default L-insertion assigns L-tones to any left-over vowels. The crucial point about the rule of H-spread is that it spreads only onto vowels that have not been assigned a tone. It does not spread a H onto a V-slot that is already linked to either a H-tone or a L-tone. This fact is easily accounted for if the vowels that are not 'accented' are underlyingly toneless, but becomes somewhat more difficult to explain if L-tones are present as part of the 'basic tone melody'.

There are several points that need to be made about the above analysis of Luganda. First, since Hyman did not view the default insertion of L-tones as a unified process, I must show why two mechanisms are not required. Hyman assumed that surface L-tones to the right of a H-tone are obtained by a rule that inserts a single L-tone that spreads onto any available vowels. L-tones to the left of a H-tone

are obtained in Hyman's analysis by linking a L 'boundary' tone. The reason that these rules could not be collapsed concerned basically their relationship with the rule of H-spread (17). For Hyman, if a single L-tone were inserted both before and after a H-tone, then a word like àbàpákàsì would have a derived representation like the following:

(19) a + ba + pakas + i
 | | |
 L H L

Hence, by the formulation of H-spread given in (17), we would incorrectly expect the H in (19) to spread onto the toneless syllable ba. This problem derives from the assumption that a single L is inserted. According to the proposal of this thesis, a L-tone is inserted for every toneless vowel, when default assignment of tones takes place. Hence there would never be a representation like (19) on which phonological rules could act.

Moreover, for the theory of underspecification outlined in the previous chapter, rule (17) as formulated is an impossible rule, since it refers to a L-tone ([-Upper]) before the default rule assigning L-tones has applied. That is, a rule cannot refer both to [-Upper] and to toneless vowels. This problem can be solved by simply ordering H-spread before Lowering instead of after it. This allows a theoretically acceptable formulation of H-spread, as in (20), and requires a slight reformulation of Lowering, as in (21).

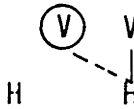
(20) H-spread (Luganda): (revised) 

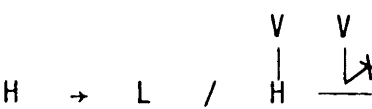
(21) Lowering: (revised) 

An interesting point about the rule of H-spread is that it applies across word-boundaries, and must therefore be a post-lexical rule. And since default insertion of L-tones takes place after the application of H-spread, this means that default tonal values are assigned post-lexically in Luganda, as they are in Yoruba. Hence lexical rules in Luganda are predicted to make reference only to H-tones but never to L-tones, since L-tones are not introduced in the lexicon.

In closing this brief discussion of Luganda, I wish to stress that by accounting for 'accent' in Luganda by pre-linking tones, rather than by introducing accentual diacritics, we derive a considerably more restrictive theory. Not only can rules not refer to accents (as distinct from tones), but they can only refer to H-tones until after default L-insertion has applied.

8. Tonga

Since Meeussen's (1963) analysis of Tonga, it seems to be generally agreed that syllables in Tonga belong to either of two tonal classes: a 'marked' class and an 'unmarked' class. What is not as clear is precisely how these tonal classes are to be characterized.

It should be stressed that no more than two classes appear to be necessary. In Goldsmith's (1981) account, it is proposed that autosegmental theory can characterize the two classes as 'accented' and 'unaccented'. As mentioned above, the accented class is distinguished by the inclusion in underlying representations of one or more accentual diacritics. The unaccented class is characterized underlyingly by the absence of such diacritics. For example, the stem si^{*} 'smoke' is lexically accented, while the stem su 'flour' is not. When two unaccented prefixes are added to these stems, we obtain results like the following: íbúsì 'smoke'; ìbùsù 'flour'. The accented form is accounted for in Goldsmith (1981) by assigning a H L^{*} tone melody, where the L is linked to the accented vowel and the H spreads onto any unaccented vowels to the left:

$$(22) \quad i + bu + s\overset{*}{i} \rightarrow \begin{array}{c} i + bu + s\overset{*}{i} \\ \quad \quad \quad \downarrow \quad \downarrow \\ \quad \quad \quad H \quad L \end{array}$$

Concerning the unaccented stems, Halle and Vergnaud propose that the L-tones that surface in such cases are default values. I will adopt this suggestion, but differ from Halle and Vergnaud's account in that I assume the default value to be an autosegment.⁵

$$(23) \quad i + bu + su \rightarrow \begin{array}{c} i + bu + su \\ \downarrow \quad \downarrow \quad \downarrow \\ L \quad L \quad L \end{array}$$

The issue to be addressed in this section is whether or not the intermediate step of 'accents' is required in the derivation of tonal

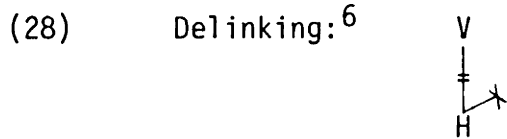

Since Delinking results in vowels that are toneless, Default L-insertion (13) will subsequently apply to give us a surface L on the underlyingly 'accented' vowel. For example, Delinking and Default L-insertion will apply to the representation in (27) as follows:

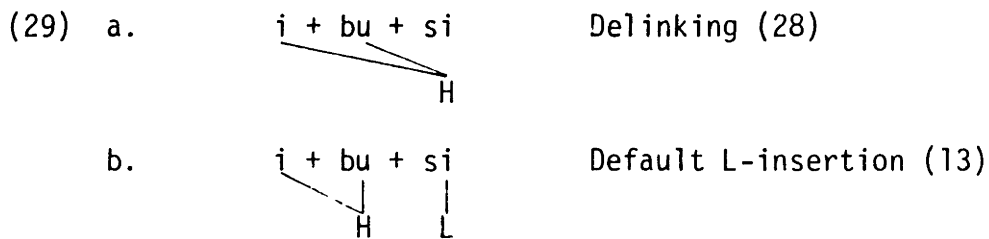

Before going on to examine more facts of Tonga, a number of points should be stressed. First, consider the rules of H-spread in Tonga and Luganda (25 & 26). Under the analysis of this chapter, the two rules are formally very similar. Both spread a linked H-tone onto any free tone-bearing units to the left. Under an accentual analysis, the rules become formally quite distinct because of assumptions about the nature of tone-spreading. In the case of Luganda, a rule is required to spread the accented H to its left; in Tonga, on the other hand, the floating H of the H L* melody spreads by convention. Apart from the fact that there are problems with allowing automatic spreading of tones, such an approach fails to capture the similarity of the phenomena in Tonga and Luganda, two closely related languages.

A second point concerns underlying representations of 'marked' syllables. In both 'accentual' and 'pre-linking' accounts, Tonga and Luganda are treated analogously. That is, in an accentual approach, 'marked' syllables in both languages are assigned an accentual diacritic; in a pre-linking approach, 'marked' syllables are assigned a lexical H-tone. The two approaches differ considerably, however, in their approach to deriving the surface L that appears on underlyingly 'marked' syllables in Tonga, as opposed to the H that appears on such syllables in Luganda. In an accentual approach, different Basic Tone Melodies are assigned in the two languages; in the pre-linking approach, a rule derives the L-tone in Tonga.

This difference is interesting for the following reason. In a number of verb tenses, 'marked' syllables do in fact surface in Tonga with a H. In the accentual approach of Goldsmith (1981) and Halle and Vergnaud (1982), such cases require the addition of rules of accent deletion and/or rules of tonal adjustment. In the approach taken here, such cases are suggested to result from the blocking of Delinking in certain cases. Hence, where in the accentual approach, such cases reflect departures from underlying accentual patterns, in the approach taken here, they represent a more transparent realization of the underlying pattern.

In the following sections, I will examine phenomena concerning two types of rules in Goldsmith's analysis of Tonga. First, I will consider cases where Goldsmith argued for accentual rules. Second, I will consider cases where a rule seems to refer to both tone and accent. In all cases, it will be shown that a purely tonal analysis is

at least as satisfactory as an accentual one, and in some cases, clearly to be preferred.

8.1 Verb bases

Verbs in Tonga are of two types. The first type bears a lexical 'accent' while the second does not. What is striking about the accented class, however, is that the accent is always on the first syllable of the verb base.

- (30) a. ^{*}bon 'see'
 b. ^{*}silik 'care for'
 c. ^{*}swiilil 'listen to'

Within an accentual framework, this can only be accounted for by stipulation. Within a tonal approach, on the other hand, such facts can be accounted for by assuming that the H-tones present in such verb forms are unlinked, and associated to the first vowel by the normal left-to-right association conventions. This is a strong argument for a tonal analysis of Tonga. In the standard autosegmental approach to tone, pre-linking of tones is resorted to only when linkings are not by convention. The fact that linkings are by convention in Tonga suggests that verb bases are of the form given in (31).

- (31)
$$\left[\begin{array}{l} \sigma (\sigma) (\sigma) \\ (H) \end{array} \right]$$

Verbs are of one or more syllables, with or without a lexical H-tone.

When the H-tone is present, it associates by left-to-right convention on the first cycle. Additional evidence for the cycle will be seen in sections 8.6 and 8.7 below; there will also be evidence for other free tones in Tonga.

8.2 Initial H-deletion

Before turning to the possible reasons for an accentual analysis of Tonga, I will briefly discuss two rules that will be necessary for an understanding of later cases.

In finite verbal forms, Goldsmith shows that there is a rule that deletes an initial H-tone.

(32) Initial H-deletion: $H \rightarrow \phi / \left[\begin{array}{l} \text{Verb} \text{ —} \\ \text{_____} \end{array} \right]$

For example, the difference between H-toned stems and toneless stems is neutralized in cases like the following:

(33) a. [tu [1a [[lang] a]]] 'we look for'
 b. [tu [1a [[[bon] a]]]] 'we see'
 [[[[H]]]]

In (33a), the verb stem lang is toneless, while in (33b), the stem bon bears a H-tone. But the H of bon is deleted by Initial H-deletion, so the surface forms of both cases have L-tones throughout: tùlàlàngà, tùlàbònà.

8.3 Downstep creation

The second important rule is one of downstep creation. Consider, for example, the contrast between the unprefix and prefixed forms for the word 'lizard', namely tòmbélà and bá!tòmbélà.⁷

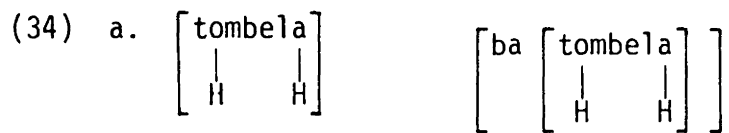

H-spread (25) applies in both cases producing the following result:



Post-lexically, Delinking (28) will apply:



Following the Relinking Condition proposed in chapter 3 (figure 39), the floating H-tone in (34c) will not relink. I assume that it therefore deletes, although nothing rests on this assumption. Default L-insertion (13) then applies, giving:



We have now correctly derived the unprefix form tòmbélà. To derive the prefixed form, Goldsmith proposes the following rule:

(35) Downstep creation:
$$\begin{array}{ccc} V & V & V \\ | & | & | \\ H & L & H \end{array}$$

This rule spreads a H onto the preceding L in a H L H sequence. The L will automatically be delinked (NB: Halle and Vergnaud 1982) since Tonga does not allow more than one tone to be linked to a single tone-bearing unit.

Downstep creation will apply to the form in (34d) to derive bá'tómbéà.

(36)
$$\left[\begin{array}{ccc} \text{batombela} \\ | \quad | \quad | \\ H \quad L \quad H \quad L \end{array} \right]$$

8.4 Meeussen's rule

The first 'accentual' rule of Goldsmith's analysis that I will examine is Meeussen's rule. According to Goldsmith, this rule deletes the second accent in a sequence of two accents prior to the insertion of tone melodies. By using $\overset{*}{V}$ to indicate an accented vowel and $\overset{\circ}{V}$ to indicate an unaccented vowel, this rule can be formalized as:

(37) Meeussen's rule: $\overset{*}{V} \rightarrow \overset{\circ}{V} / \overset{*}{V} C_0 _$

There are two types of cases that require Meeussen's rule. The first, I will only mention briefly since Halle and Vergnaud show that even within an accentual approach to Tonga, the rule is not required. Consider a verb such as bàlábàbônâ 'they are seeing them'. In Goldsmith's analysis, such a word will have an underlying form as in

(38a), Meeussen's Rule will derive the form in (38b), and assignment of Basic Tone Melodies will derive the form in (38c).

- (38) a. $\left[\overset{*}{b\grave{a}} \left[l\grave{a} \left[\overset{*}{b\grave{a}} \left[\overset{*}{b\acute{o}n} \right] a \right] \right] \right]$
- b. $\overset{*}{b\grave{a}} + l\grave{a} + \overset{*}{b\grave{a}} + \overset{\circ}{b\acute{o}n} + a$ Meeussen's Rule (37)
- c. $\overset{*}{b\grave{a}} + l\grave{a} + \overset{*}{b\grave{a}} + b\acute{o}n + a$ Basic Tone Melody
- $\begin{array}{c} | \\ H \quad L \end{array} \quad \begin{array}{c} | \\ H \quad L \end{array}$

Goldsmith's conventions of linking and spreading, in conjunction with the rule of Initial H-deletion (32), will correctly derive bàlá**á**bà**ò**à.

Halle and Vergnaud (1982) show that such cases do not require Meeussen's rule, however, if free tones do not link automatically when there is no available free tone-bearing unit. Hence under their assumptions, the form in (38) would be derived as follows:

- (39) a. $\overset{*}{b\grave{a}} + l\grave{a} + \overset{*}{b\grave{a}} + \overset{*}{b\acute{o}n} + a$ Basic Tone Melody
- $\begin{array}{c} | \\ H_1 \quad L \end{array} \quad \begin{array}{c} | \\ H_2 \quad L \end{array} \quad \begin{array}{c} | \\ H_3 \quad L \end{array}$

\underline{H}_1 will delete by Initial H-deletion (32); \underline{H}_2 will link to the vowel of la; \underline{H}_3 will remain in the string without linking, and consequently without phonetic effect. Hence, this approach also correctly derives bàlá**á**bà**ò**à.

In the tonal approach taken here, such forms are derived without requiring any new rules. As seen in (40), H-spread (25), Delinking (28) and Default L-insertion (13) give the correct surface form in such a case.

- (40) a. $\left[\begin{array}{c} \text{ba} \\ | \\ \text{H} \end{array} \left[\begin{array}{c} \text{la} \\ | \\ \text{H} \end{array} \left[\begin{array}{c} \text{ba} \\ | \\ \text{H} \end{array} \left[\begin{array}{c} \text{bon} \\ | \\ \text{H} \end{array} \text{a} \right] \right] \right] \right]$
- b. $\left[\begin{array}{c} \text{ba} \\ | \\ \text{H} \end{array} \left[\begin{array}{c} \text{la} \\ | \\ \text{H} \end{array} \left[\begin{array}{c} \text{ba} \\ | \\ \text{H} \end{array} \left[\begin{array}{c} \text{bon} \\ | \\ \text{H} \end{array} \text{a} \right] \right] \right] \right]$ H-spread (25)
- c. $\left[\begin{array}{c} \text{ba} \text{la} \text{ba} \text{bon} \text{a} \\ | \quad | \quad | \\ \text{H} \quad \text{H} \quad \text{H} \end{array} \right]$ Delinking (28)
- d. $\left[\begin{array}{c} \text{ba} \text{la} \text{ba} \text{bon} \text{a} \\ | \quad | \quad | \quad | \quad | \\ \text{L} \quad \text{H} \quad \text{L} \quad \text{L} \quad \text{L} \end{array} \right]$ Default L-insertion (13)

Hence in the tonal analysis of this chapter, as in the accentual analysis of Halle and Vergnaud, Meeussen's rule (37) is redundant in cases like bàlábàbònà 'they are seeing them'.

In the second class of cases, both Goldsmith and Halle and Vergnaud require application of Meeussen's rule. The cases in question are the 'weak' forms of verbs that result from assigning emphasis to a verb's object. Compare the following:

- (41) a. $\left[\begin{array}{c} \text{ndàkátòlà} \\ \text{V} \end{array} \right] \left[\begin{array}{c} \text{nyàmà} \\ \text{N} \end{array} \right]$ 'I TOOK meat' (strong)
- b. $\left[\begin{array}{c} \text{ndàká}^! \text{tòlá} \\ \text{V} \end{array} \right] \left[\begin{array}{c} \text{nyàmà} \\ \text{N} \end{array} \right]$ 'I took MEAT' (weak)

In accentual terms, the weak form is distinguished from the strong form by the presence of an 'accent' on the first syllable of a noun or particle immediately following the verb. That is, when the noun object is emphasized, it is assigned an initial accent. Hence in the strong form above (41a), the noun object is unaccented; in the

weak form (41b), nyama has been assigned an accent on its first syllable.

Without bothering to show how this proposal works in Goldsmith's and Halle and Vergnaud's accentual analyses, it is worthwhile demonstrating that the proposal to assign an accent to the object of the weak forms translates directly into the tonal approach taken here -- we simply assign a H-tone to the first syllable of the object.

- (42) a. $\left[\begin{array}{ccccccc} \text{ndi} & + & \text{a} & + & \text{ka} & + & \text{tol} & + & \text{a} \end{array} \right] \left[\begin{array}{c} \text{nyama} \\ | \\ \text{H} \end{array} \right]$ Strong
- b. $\left[\begin{array}{ccccccc} \text{ndi} & + & \text{a} & + & \text{ka} & + & \text{tol} & + & \text{a} \end{array} \right] \left[\begin{array}{c} \text{nyama} \\ | \\ \text{H} \end{array} \right]$ Weak

After the assignment of the H-tone in the weak forms, the two sentences in (42) are derived without complication. First, consider the strong form (42a):

- (43) $\left[\text{ndi} \left[\begin{array}{c} \text{a} \\ | \\ \text{H} \end{array} \left[\text{ka} \left[\begin{array}{c} \text{tol} \\ | \\ \text{H} \end{array} \right] \text{a} \right] \right] \right] \left[\begin{array}{c} \text{nyama} \\ | \\ \text{H} \end{array} \right]$ Strong
- $\left[\text{ndi} \left[\begin{array}{c} \text{a} \\ | \\ \text{H} \end{array} \left[\text{ka} \left[\begin{array}{c} \text{tol} \\ | \\ \text{H} \end{array} \right] \text{a} \right] \right] \right] \left[\begin{array}{c} \text{nyama} \\ | \\ \text{H} \end{array} \right]$ H-spread (25)⁸
- $\left[\begin{array}{c} \text{ndakatola} \\ | \\ \phi \quad \text{H} \end{array} \right]$ Initial H-deletion (32)
- $\left[\begin{array}{c} \text{ndakatola} \\ | \\ \text{H} \end{array} \right]$ Delinking (28)

Default L-insertion (13) applies to both words, correctly deriving:
ndàkátòlà nyàmà.

Turning to the weak form, we obtain the following derivation for
the sentence in (42b):

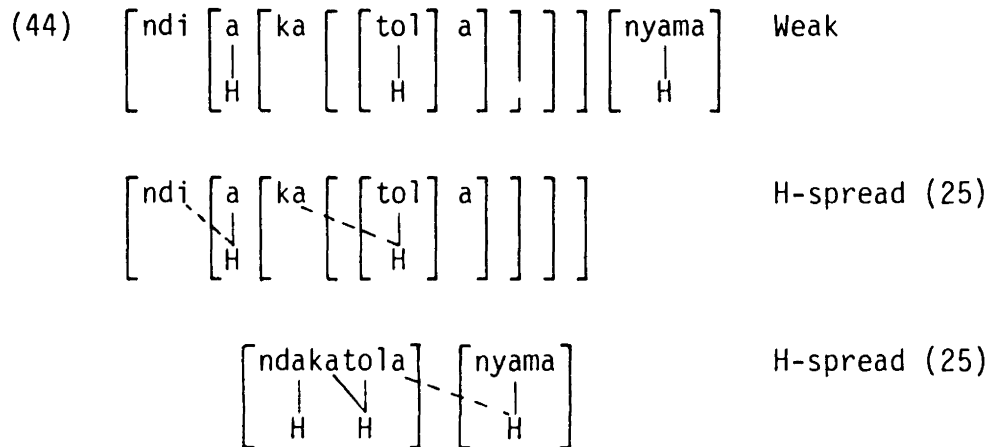

I assume that H-spread applies both lexically -- in the derivation
of the verb -- and post-lexically -- between the verb and its object.
Evidence for this position will be seen in section 8.6. The post-
lexical derivation then continues as follows:

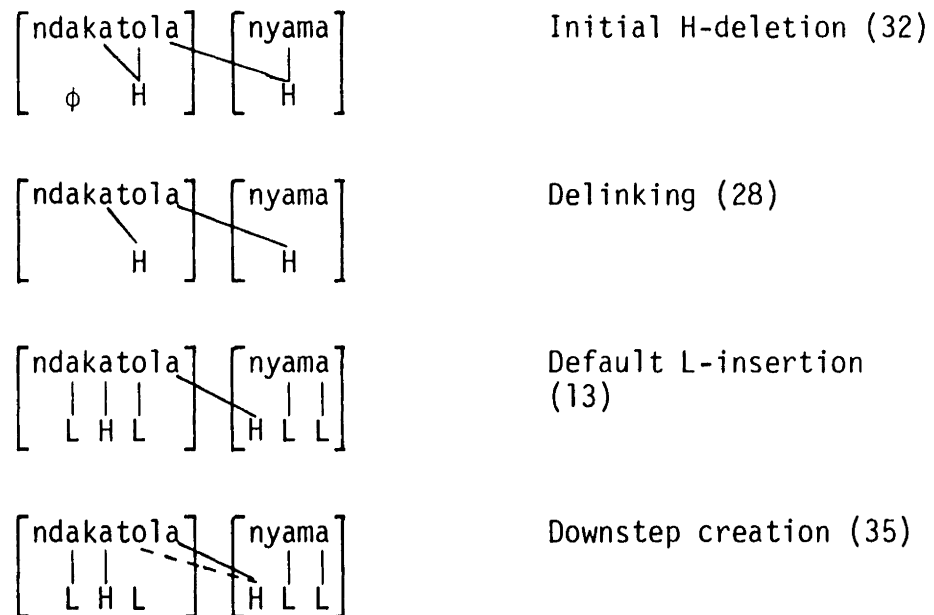

Hence, we derive the correct surface form, ndàká[!]tólá nyàmà.

Given this much discussion of 'strong' and 'weak' forms, we are now ready to turn to the cases that require Meeussen's rule in both Goldsmith's and Halle and Vergnaud's analyses. Consider, for example, the following cases reproduced from Halle and Vergnaud, where the letter 0 represents the initial accented syllable of the word following the verb.

- (45) a. $[ndi + \overset{*}{a} + b\overset{*}{o}n + a] [\overset{*}{0} \dots \rightarrow \underline{ndàbóná \grave{o}} \quad \text{Tense 16}$
- b. $[ndi + \overset{*}{a} + b\overset{*}{a} + b\overset{*}{o}n + a] [\overset{*}{0} \dots \rightarrow \underline{ndàbábóná \grave{o}} \quad \text{Tense 16}$
- c. $[ndi + \overset{*}{a} + ka + b\overset{*}{a} + b\overset{*}{o}n + a] [\overset{*}{0} \dots \rightarrow \underline{ndàká[!]bábóná \grave{o}} \quad \text{Tense 19}$

In all three cases, we obtain incorrect results if we assign tonal melodies and apply the tonal rules of Goldsmith or Halle and Vergnaud without first changing the accentual structure of such weak verbs. The solution adopted in both analyses, therefore, was to have Meeussen's rule (37) apply in such cases, changing the forms in (45) into those in (46).

- (46) a. $[ndi + \overset{*}{a} + b\overset{\circ}{o}n + a] [\overset{*}{0} \dots$
- b. $[ndi + \overset{*}{a} + b\overset{\circ}{a} + b\overset{\circ}{o}n + a] [\overset{*}{0} \dots$
- c. $[ndi + \overset{*}{a} + ka + b\overset{\circ}{a} + b\overset{\circ}{o}n + a] [\overset{*}{0} \dots$

The tonal rules as formulated will then derive the correct surface tonal

forms.

In contrast with the above approach, however, the analysis of this chapter requires no additional rules to account for the forms in (45). In (47) below, I give the forms for the three cases under discussion as they would appear after application of H-spread (25).

- (47) a. $\left[\begin{array}{cccc} \text{nd} & \grave{\text{a}} & \text{bón} & \acute{\text{a}} \\ | & | & | & | \\ \text{H}_1 & \text{H}_2 & & \text{H}_3 \end{array} \right] \left[\begin{array}{c} \hat{\text{O}} \dots \\ | \\ \text{H}_3 \end{array} \right]$
- b. $\left[\begin{array}{cccc} \text{nd} & \grave{\text{a}} & \text{bá} & \text{bón} & \acute{\text{a}} \\ | & | & | & | & | \\ \text{H}_1 & \text{H}_2 & \text{H}_3 & & \text{H}_4 \end{array} \right] \left[\begin{array}{c} \hat{\text{O}} \dots \\ | \\ \text{H}_4 \end{array} \right]$
- c. $\left[\begin{array}{cccc} \text{nd} & \grave{\text{a}} & \text{ká} & \text{bá} & \text{bón} & \acute{\text{a}} \\ | & | & | & | & | & | \\ \text{H}_1 & & \text{H}_2 & \text{H}_3 & & \text{H}_4 \end{array} \right] \left[\begin{array}{c} \hat{\text{O}} \dots \\ | \\ \text{H}_4 \end{array} \right]$

For purposes of exposition, I have numbered the H-tones in the examples in (47). H_1 in all three examples will ultimately undergo Initial H-deletion (32), so it is no surprise that the initial tone is always $\underline{\text{L}}$ in the above examples. What is surprising is that H-tones are retained on certain syllables in spite of the rule of Delinking (28). For example, the $\underline{\text{H}}$ of bon is apparently not delinked in all three cases. An interesting generalization emerges: Delinking applies to the cases in (47) only if the relevant H-tone is linked to more than one tone-bearing unit. That is, H_3 undergoes Delinking in (47a); H_4 undergoes Delinking in (47b); and in (47c), both H_2 and H_4 are subject to Delinking. Hence, under a tonal analysis of Tonga, no new rule is required for weak forms -- we need only impose a condition on the application of Delinking.

(48) Delinking (revised):

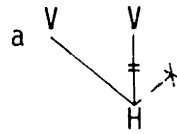

Condition: a = required in weak verb forms only

As formulated in (48), Delinking removes the rightmost association line from a multiply associated H-tone in all cases, and from a H-tone that is linked to a single tone-bearing unit, only in non-'weak' forms.

In conclusion, we see that there is nothing in the facts of such weak forms that requires the introduction of accents into an analysis of Tonga. Moreover, no tonal equivalent of Meeussen's rule is required in the analysis presented here. The correct forms are derived by imposing a condition on the independently motivated rule of Delinking.

8.4.1 Rule application

It is appropriate at this point to consider the question of where the various rules considered so far apply -- lexically or post-lexically.

The weak verb forms are particularly instructive on this issue. Consider the derivation in (44) above. There we have clear evidence that H-spread (25) applies across word-boundaries. This is a clear indication that H-spread applies post-lexically; I have also suggested that it applies lexically, but the crucial evidence will not come until section 8.6.

Since H-spread applies post-lexically, Initial H-deletion (32), Delinking (48) and Default L-insertion (13) must all apply post-lexically, and not lexically. Consider first the case of Default L-insertion. In the derivation of ndàkà[!]tólá nyàmà in (44), it was proposed that the output of the lexicon was the following:

$$(49) \quad \left[\begin{array}{c} \text{ndakatola} \\ | \quad \diagdown \\ \text{H} \quad \text{H} \end{array} \right] \left[\begin{array}{c} \text{nyama} \\ | \\ \text{H} \end{array} \right]$$

If Default L-insertion had applied in the lexicon, then instead of (49), we would have (50):

$$(50) \quad \left[\begin{array}{c} \text{ndakatola} \\ | \quad \diagdown \quad | \\ \text{H} \quad \text{H} \quad \text{L} \end{array} \right] \left[\begin{array}{c} \text{nyama} \\ | \quad | \\ \text{H} \quad \text{L} \end{array} \right]$$

But the structural description of H-spread is not met in (50), so after Delinking and Initial H-deletion had applied, we would incorrectly derive * ndàkátòlà nyàmà. Hence, Default L-insertion must not apply lexically in Tonga.

Looking at the same example, imagine that Initial H-deletion (32) had applied lexically. Then instead of the representation in (49), the output of the lexicon would be as in (51).

$$(51) \quad \text{a.} \quad \left[\begin{array}{c} \text{ndakatola} \\ \quad \quad \diagdown \\ \quad \quad \text{H} \end{array} \right] \left[\begin{array}{c} \text{nyama} \\ | \\ \text{H} \end{array} \right]$$

In this case, post-lexical application of H-spread would overgenerate.

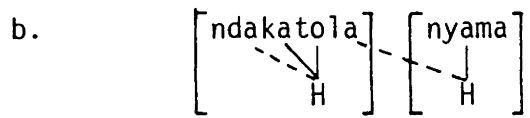

Application of Delinking (48), Default L-insertion (13) and Downstep creation (35) would incorrectly result in * ndáká!tólá nyàmà.

Hence, this example shows that Initial H-deletion (32) must apply post-lexically, and not lexically.

Turning to Delinking (48), the same example shows that Delinking -- like Default L-insertion and Initial L-insertion -- must only apply post-lexically. Lexical application of Delinking would again cause post-lexical application of H-spread to spread too far. (I will leave construction of the example to the doubting reader.)

Lastly, the structural description of Downstep Creation (35) requires the previous assignment of L-tones. Therefore, since Default L-insertion takes place only at the post-lexical stratum, Downstep creation, too, must apply post-lexically.

Hence, although the tone association within verb stems shows that tone association is cyclic (and therefore lexical), most of the rules examined so far must apply post-lexically. Note, however, that while H-spread must apply post-lexically, nothing goes wrong if it also applies lexically. And as we will see later, it does in fact apply at both lexical and post-lexical strata.

8.5 Accent shift

A second case of a putative accent rule concerns what Goldsmith

terms Accent Shift. The problem is how to derive certain Recent Past (strong) verb forms such as the following: ⁹

- (52)
- A. ndàbónà
 - B. ndàbábònà
 - C. wábònà
 - D. wábàbònà
 - E. ndàbálàngà
 - F. wábàlàngà
 - G. wàlàngà

The letters A - F correspond to the boxes on page 21 of Goldsmith (1981) and I include G as an additional example. In his article, Goldsmith argues that facts such as those found in the Recent Past forms above require an accent shift rule such as:

- (53) Accent Shift: a. $-a^* - \vec{V} V \rightarrow -a^* - V \vec{V}$ or,
- b. $a^* \vec{V} \rightarrow a^* \vec{V}$

The arrow in (53b) indicates a 'post-accent'. This means that the vowel following the post-accent will become accented. The rule in (53) is problematic for the account of this chapter in that it is formulated as applying to accents, but in addition it turns out that it only accounts for forms such as in (52) if major revisions are made in the Elsewhere Condition. Goldsmith proposes that the correct notion of disjunctivity is "one according to which the more GENERAL rule can be precluded from applying not only by the ACTUAL application

of the more specific rule, but the PRESENCE of the more specific rule -- that is, its potential application later in the derivation. Furthermore, this sensitivity of the rule-application algorithm extends to an 'awareness' as to whether the more specific rule ... may apply to that SPECIFIC form." (Goldsmith 1981 p.24)

Halle and Vergnaud argue that such a powerful version of the Elsewhere Condition is not in fact required for the facts of Tonga. Since the theoretical revisions that Goldsmith's analysis requires are neither independently motivated nor necessary for Tonga, they propose that his analysis of the Recent Past tense should be abandoned. They propose instead the following rule for the cases under discussion.

$$(54) \quad \text{SD: } \begin{bmatrix} C \overset{*}{V} C \overset{*}{V} \\ L H L \end{bmatrix} \quad \text{SC: link } \underline{H} \text{ to nearest accessible vowel on its right.}$$

Although this rule does not require as far-reaching a theoretical revision as the proposal of Goldsmith, it is nevertheless incompatible with the approach of this chapter, since it requires reference to diacritical accents as well as tone.

I wish to propose here that the facts in (49) should be accounted for by two rules. The first rule applies to all those cases that begin with a glide (ie. 49 C, D, F and G). Below are underlying and surface forms for these cases:

$$(55) \quad C. \quad \left[\begin{array}{c} u \\ | \\ H \end{array} \left[\begin{array}{c} a \\ | \\ H \end{array} \left[\left[\begin{array}{c} \text{bon} \\ | \\ H \end{array} \right] a \right] \right] \right] \rightarrow \text{wábò\`n\`a}$$

- D. $\left[\begin{array}{c} u \\ | \\ H \end{array} \left[\begin{array}{c} a \\ | \\ H \end{array} \left[\begin{array}{c} ba \\ | \\ H \end{array} \left[\begin{array}{c} [bon] \\ | \\ H \end{array} a \right] \right] \right] \right] \right] \rightarrow wábàbònâ$
- F. $\left[\begin{array}{c} u \\ | \\ H \end{array} \left[\begin{array}{c} a \\ | \\ H \end{array} \left[\begin{array}{c} ba \\ | \\ H \end{array} \left[\begin{array}{c} [lang] \\ | \\ H \end{array} a \right] \right] \right] \right] \right] \rightarrow wábàlàngâ$
- G. $\left[\begin{array}{c} u \\ | \\ H \end{array} \left[\begin{array}{c} a \\ | \\ H \end{array} \left[\begin{array}{c} [lang] \\ | \\ H \end{array} a \right] \right] \right] \right] \rightarrow wàlàngâ$

Given the representations in (55), we would expect Delinking (48) to dissociate all H-tones in all four cases, thereby resulting in L-tones throughout. Such a result would, of course, be incorrect. To derive the correct result, I propose a rule deleting the second H-tone in such cases.

$$(56) \text{ Second H-deletion: } H \rightarrow \phi / \left[\begin{array}{c} V \\ | \\ H \end{array} \begin{array}{c} V \\ | \\ \underline{\quad} \end{array} \right]$$

This rule has to apply before the post-lexical application of H-spread since Second H-deletion feeds H-spread in examples C, D and F of (55).¹⁰ Consider the following derivations:

$$(57) \text{ D: } \left[\begin{array}{c} u \\ | \\ H \end{array} \left[\begin{array}{c} a \\ | \\ H \end{array} \left[\begin{array}{c} ba \\ | \\ H \end{array} \left[\begin{array}{c} [bon] \\ | \\ H \end{array} a \right] \right] \right] \right] \right] \quad \text{G: } \left[\begin{array}{c} u \\ | \\ H \end{array} \left[\begin{array}{c} a \\ | \\ H \end{array} \left[\begin{array}{c} [lang] \\ | \\ H \end{array} a \right] \right] \right] \right]$$

First, Second H-deletion (56) applies to both cases:

$$\left[\begin{array}{c} u \\ | \\ H \end{array} \left[\begin{array}{c} \phi \\ | \\ H \end{array} \left[\begin{array}{c} ba \\ | \\ H \end{array} \left[\begin{array}{c} [bon] \\ | \\ H \end{array} a \right] \right] \right] \right] \right] \quad \left[\begin{array}{c} u \\ | \\ H \end{array} \left[\begin{array}{c} \phi \\ | \\ H \end{array} \left[\begin{array}{c} [lang] \\ | \\ H \end{array} a \right] \right] \right] \right]$$

Post-lexically, H-spread applies to example D:

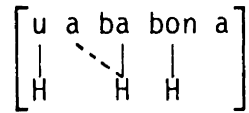

Initial H-deletion (32) applies to both cases:

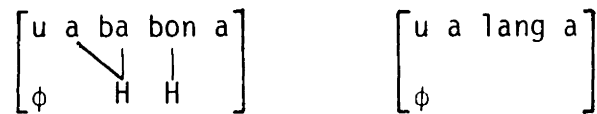

Delinking (48) and Default L-insertion then apply:

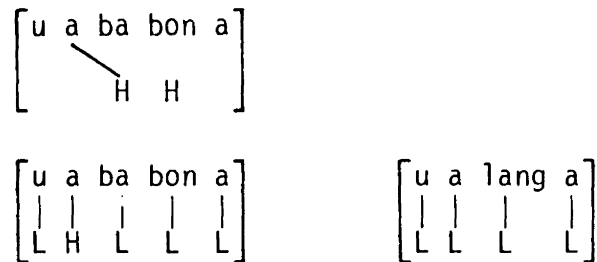

After glide formation, the correct forms are derived for such cases, namely wábàbònà and wàlàngà.

The second class of cases in (52) have the following underlying forms:

- (58) A. $\left[\text{ndi} \left[\begin{array}{c} \text{a} \\ | \\ \text{H} \end{array} \left[\begin{array}{c} \text{bon} \\ | \\ \text{H} \end{array} \right] \text{a} \right] \right] \rightarrow \text{ndàbónà}$
- B. $\left[\text{ndi} \left[\begin{array}{c} \text{a} \\ | \\ \text{H} \end{array} \left[\begin{array}{c} \text{ba} \\ | \\ \text{H} \end{array} \left[\begin{array}{c} \text{bon} \\ | \\ \text{H} \end{array} \right] \text{a} \right] \right] \right] \rightarrow \text{ndàbábònà}$
- E. $\left[\text{ndi} \left[\begin{array}{c} \text{a} \\ | \\ \text{H} \end{array} \left[\begin{array}{c} \text{ba} \\ | \\ \text{H} \end{array} \left[\begin{array}{c} \text{lang} \\ | \\ \text{H} \end{array} \right] \text{a} \right] \right] \right] \rightarrow \text{ndàbálàngà}$

As a first point about the cases in (58), it does not seem that the rule that deletes the i of ndi can be collapsed with the glide formation rule required for the forms in (55). This is because in other cases of an i a sequence, a glide is attested. Consider, for example the following case:

$$(59) \left[\text{ka} \left[\underset{\text{H}}{\text{mu}} \left[\left[\underset{\text{H}}{\text{ti}} \right] \underset{\text{H}}{\text{a}} \right] \right] \right] \rightarrow \text{kàmùtyá} \text{ 'pour (hortative affirmative)'}'$$

This is important because the vowel of ndi blocks Second H-deletion (56) from applying to the cases in (58). I assume that the rule that deletes the i is a morphologically conditioned rule, and therefore that it must apply lexically. Since Second H-deletion must precede the i-deletion rule, this means that Second H-deletion must also apply lexically. On the other hand, the fact that cyclic application of Second H-deletion would yield incorrect results in a case like D in (57), suggests that Second H-deletion is a word-level rule.

After Second H-deletion has had a chance to apply, and the i of ndi has been deleted, I propose that the following rule applies:

$$(60) \text{ Recent Past Spread: } ^{11} \left[\begin{array}{ccc} \text{V} & \text{V} & \text{V} \\ | & | & \text{---} \\ \text{H} & \text{H} & \end{array} \right]$$

Consider the following sample derivations.

$$(61) \text{ A. } \left[\text{ndi} \left[\underset{\text{H}}{\text{a}} \left[\left[\underset{\text{H}}{\text{bon}} \right] \underset{\text{H}}{\text{a}} \right] \right] \right] \quad \text{B. } \left[\text{ndi} \left[\underset{\text{H}}{\text{a}} \left[\underset{\text{H}}{\text{ba}} \left[\left[\underset{\text{H}}{\text{bon}} \right] \underset{\text{H}}{\text{a}} \right] \right] \right] \right]$$

First, the i of ndi is deleted:

$$\left[\text{nd}\phi \left[\underset{\text{H}}{\text{a}} \left[\left[\underset{\text{H}}{\text{bon}} \right] \text{a} \right] \right] \right] \quad \left[\text{nd}\phi \left[\underset{\text{H}}{\text{a}} \left[\underset{\text{H}}{\text{ba}} \left[\left[\underset{\text{H}}{\text{bon}} \right] \text{a} \right] \right] \right] \right] \right]$$

Recent Past Spread (60) then applies:

$$\left[\text{nd} \left[\underset{\text{H}}{\text{a}} \left[\left[\underset{\text{H}}{\text{bon}} \right] \text{a} \right] \right] \right] \quad \left[\text{nd} \left[\underset{\text{H}}{\text{a}} \left[\underset{\text{H}}{\text{ba}} \left[\left[\underset{\text{H}}{\text{bon}} \right] \text{a} \right] \right] \right] \right] \right]$$

Note that as formulated, Recent Past Spread will automatically delink the third H in ndàbábònà, since Tonga does not allow multiple linkings of tones. However, since Recent Past Spread does not specifically delink the H, the Relinking Condition discussed in chapter 3 (figure 39) will allow the association conventions to relink the free H-tone. I point this out for the sake of clarity, but nothing hinges the the reassociation -- or lack thereof -- in this case.

Post-lexically, Initial H-deletion (32), Delinking (48) and Default L-insertion (13) will then apply:

$$\begin{array}{ll} \left[\text{nd} \text{ a } \text{bon} \text{ a} \right] & \left[\text{nd} \text{ a } \text{ba} \text{bon} \text{ a} \right] & \text{Initial H-del. (32)} \\ \left[\begin{array}{c} \phi \\ \text{H} \end{array} \right] & \left[\begin{array}{c} \phi \\ \text{H} \text{ H} \end{array} \right] & \text{\& Delinking (48)} \\ \\ \left[\text{nd} \text{ a } \text{bon} \text{ a} \right] & \left[\text{nd} \text{ a } \text{ba} \text{bon} \text{ a} \right] & \text{Def. L-insertion} \\ \left[\begin{array}{c} \text{L} \\ \text{H} \\ \text{L} \end{array} \right] & \left[\begin{array}{c} \text{L} \\ \text{H} \\ \text{L} \\ \text{L} \end{array} \right] & \text{(13)} \end{array}$$

Hence we correctly derive ndàbónà and ndàbábònà.

To conclude the discussion of this tense, it has been shown that

no enrichment of tonal theory is required to derive the forms in (52). There is no need to invoke a powerful and otherwise unmotivated version of the Elsewhere Condition, nor is it necessary to make reference to diacritical accents in tonal rules. Although the analysis that I have presented requires two rules instead of the one rule proposed by either Goldsmith or Halle and Vergnaud, it is questionable that the cases discussed really motivate the type of enrichment of the theory that the inclusion of accents would entail. Moreover, there is evidence that the processes in the Recent Past tense forms should be distinguished as resulting from two separate rules since one of the rules -- namely Second H-deletion (56) -- applies in another tense discussed by Goldsmith.

8.6 Hortative Affirmative

The Hortative Affirmative is interesting for two reasons. First, it illustrates a case where Goldsmith proposed a rule referring to both accent and tone. Second, the rule of Second H-deletion -- proposed for the cases discussed in the previous section -- also applies in this tense.

Consider forms such as the following:

- | | | | |
|------|-------------------------|----|-------------------------|
| (62) | I | II | |
| a. | kàmù ̀ bónà | d. | kàmù ̀ lángà |
| b. | kàmùs ̀ íííkà | e. | kàmù ̀ tóbélà |
| c. | kàmùs ̀ wííííílà | f. | kàmù ̀ yándáúílà |

The H-tones throughout the stems -- which I have underlined in (62) -- indicate that the final vowel is 'accented' in this tense. This fact alone allows us to correctly derive the forms in column II of (62).

Consider kàmùtóbélà (62e), for example:

$$(63) \text{ a. } \left[\text{ka} \left[\text{mu} \left[\left[\text{tobel} \right] \text{a} \right] \right] \right]$$

H-spread (25) applies cyclically to derive:

$$\text{b. } \left[\text{ka} \left[\text{mu} \left[\left[\text{tobel} \right] \text{a} \right] \right] \right]$$

Post-lexically, Initial H-deletion (32), Delinking (48) and Default L-insertion (13) will then derive:

$$\text{c. } \left[\text{ka} \text{ mu} \text{ tobel} \text{ a} \right]$$

Hence the rules already discussed give us the desired result, kàmùtóbélà.

Consider now a form such as kàmùbátóbélà.

$$(64) \text{ a. } \left[\text{ka} \left[\text{mu} \left[\text{ba} \left[\left[\text{tobel} \right] \text{a} \right] \right] \right] \right]$$

H-spread (25) would apply to this form, deriving:

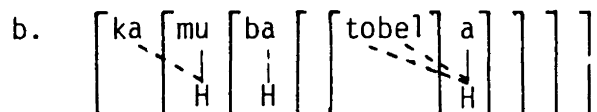

After the application of Initial H-deletion (32), Delinking (48) and Default L-insertion (13), we would expect the tone of ba to be L, whereas in fact it is H. I propose, therefore, that the Hortative Affirmative, like weak verb forms, blocks Delinking from applying to H-tones that are not multiply linked. That is, the condition on Delinking given in (48), also applies to the Hortative Affirmative. Hence Initial H-deletion (32) and Delinking (48) will derive (64c), and the application of Default L-insertion (13) will give (64d).

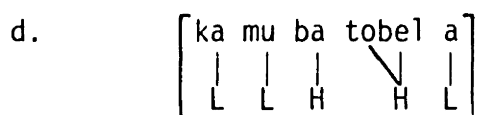
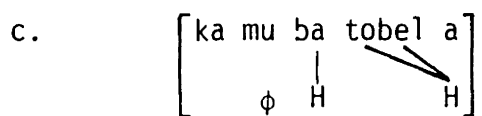

Given this approach, consider now a form like kàmùbónà (62a).

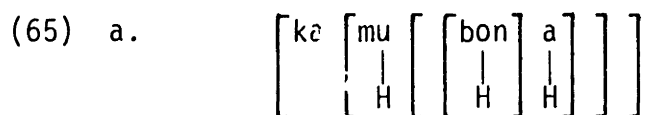

First, H-spread (25) will apply:

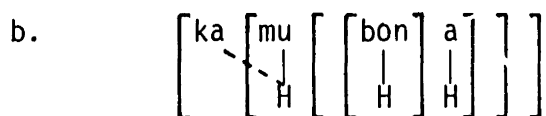

The initial H will then be deleted by Initial H-deletion (32):

$$c. \quad \begin{bmatrix} \text{ka} & \text{mu} & \text{bon} & \text{a} \\ & & | & | \\ & & \phi & \text{H} & \text{H} \end{bmatrix}$$

Delinking (48) should not affect either H-tone left in (65c) since in this tense, the rule of Delinking only delinks the rightmost association line of a multiply linked tone. Incorrectly, therefore, we would expect to derive *kàmùbóná.

To obtain the correct result in such cases, we need to apply Second H-deletion (56). Consider again the underlying form of kàmùbónà given in (65a). If Second H-deletion is revised to apply as a mirror image rule, then its structural description is met in a case like (65a), where the final vowel has been assigned an accent. The result of its application in such a case is shown in (66).

$$(66) \quad \begin{bmatrix} \text{ka} & \begin{bmatrix} \text{mu} & \begin{bmatrix} \text{bon} & \text{a} \end{bmatrix} \end{bmatrix} \\ & | & | \\ & \text{H} & \begin{bmatrix} \phi & \text{H} \end{bmatrix} \end{bmatrix}$$

Regular application of H-spread (25), Initial H-deletion (32), Delinking (48) and Default L-insertion (13) will then correctly derive kàmùbónà.

To summarize, I propose that the condition on Delinking shown earlier to be required for weak verb forms, also applies in the Hortative Affirmative. Also, the rule of Second H-deletion (56) -- reformulated as a mirror image rule -- applies in this tense.

Now consider the following form:

$$(67) \left[\text{ka} \left[\underset{\text{H}}{\text{mu}} \left[\text{ndi} \left[\left[\underset{\text{H}}{\text{bon}} \right] \underset{\text{H}}{\text{a}} \right] \right] \right] \right] \rightarrow \text{kàmùndí}^1 \text{bóná}^1$$

This form is problematic for an accentual account because the final accented vowel surfaces with a H instead of a L. To account for such a case, Goldsmith proposed the following rule:

$$(68) \text{ Double-Accent Flop: }^{12} \begin{array}{c} \star \quad \quad \quad \star \\ \text{V} \quad \text{C}_o \quad \text{V} \\ \diagdown \quad \quad \diagup \\ \text{L} \quad \text{H} \quad \text{L} \end{array}$$

In the approach taken here, the form in (67) does not require any new rules, if we assume the following: 1. the H deleted by Second H-deletion must not be multiply linked: ¹³

$$(69) \text{ Second H-deletion (revised): } \text{H} \rightarrow \phi \quad \% \quad \begin{array}{c} \text{V} \quad \text{V} \\ | \quad | \\ \text{H} \quad \text{L} \end{array} \rightarrow$$

2. H-spread (25) applies both lexically and post-lexically.

Given these two assumptions, a case like kàmùndí¹bóná¹ is derived as follows:

$$(70) \text{ a. } \begin{array}{c} \left[\text{bon} \right] \\ \vdots \\ \text{H} \end{array} \quad 1^{\text{st}} \text{ cycle: Assoc. Conv.}$$

$$\text{ b. } \left[\left[\underset{\text{H}}{\text{bon}} \right] \underset{\text{H}}{\text{a}} \right] \quad 2^{\text{nd}} \text{ cycle}$$

- c. $\left[\text{ndi} \left[\left[\text{bon} \right] \text{a} \right] \right]$ 3rd cycle: H-spread (25)
- d. $\left[\text{mu} \left[\text{ndi} \left[\left[\text{bon} \right] \text{a} \right] \right] \right]$ 4th cycle: Assoc. Conv. (13)
- e. $\left[\text{ka} \left[\text{mu} \left[\text{ndi} \left[\left[\text{bon} \right] \text{a} \right] \right] \right] \right]$ 5th cycle: H-spread (25)

Before giving the post-lexical derivation of this example, I will first make a couple of points. First, by assuming that the association of tones is cyclic, there is no need to pre-link the tones of the various prefix morphemes. Second, I have assumed that Second H-deletion (69) is a word-level rule for reasons given in section 8.5. Hence even though its structural description is met on the second cycle, it does not apply until the word has been fully derived. Note that it is crucial that Second H-deletion not apply on the second cycle, since deletion of the H of bon would derive incorrect results in (70). Finally, as formulated in (69), Second H-deletion cannot apply to (70e) since the H of bon is multiply linked. Consequently, no rule like Double-Accent Flop is required in the present analysis.

The post-lexical derivation of (70) will proceed as follows.

Initial H-deletion applies:

- (71) a. $\left[\text{ka} \text{ mu} \text{ ndi} \text{ bon} \text{ a} \right]$
 $\left[\quad \phi \quad \quad \text{H} \quad \text{H} \right]$

Delinking (48) applies to the multiply linked H.

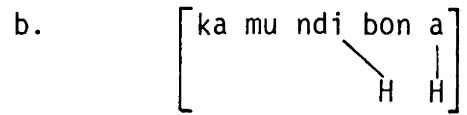

L-tones are inserted by default (13).

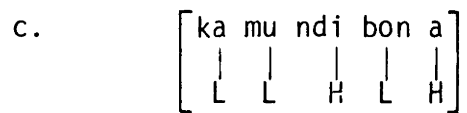

And finally, Downstep creation (35) applies.

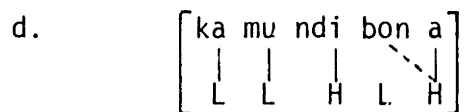

Hence we correctly derive kàmùndí[!]bóná.

There are a number of conclusions that can be drawn from the Hortative Affirmative. First, H-spread (25) applies both lexically and post-lexically. Second, the rule of Second H-deletion (69) is correctly distinguished from Recent Past Spread (60), since the former, but not the latter, also applies in the Hortative Affirmative. Third, Delinking (48) can be conditioned to apply only to multiply-linked H-tones in more than the 'weak' verb forms discussed in section 8.4, ie. the condition on (48) applies in various verb forms.

The rule of Second H-deletion is interesting with respect to rule ordering. In the derivation of kàmùndí[!]bóná (70), it was shown that the rule of H-spread must apply prior to Second H-deletion. The effect of this order is that H-spread bleeds Second H-deletion.

In an earlier example, however, we required exactly the opposite order for these two rules. In the derivation of wábàbònà (57), it was crucial that Second H-deletion be ordered first, thereby feeding H-spread. Hence, we have an apparent ordering paradox. Within the framework of lexical phonology, however, there is in fact no problem. In the derivation of wábàbònà, a lexical application of Second H-deletion precedes a post-lexical application of H-spread; in the derivation of kàmùndí[!]bóná, a lexical application of H-spread precedes a lexical application of Second H-deletion. Hence the relevant orderings are as shown in (72), where A represents the ordering required for kàmùndí[!]bóná and B represents the ordering required for wábàbònà.

(72)	A	{	H-spread (lexical application)
	B		Second H-deletion (lexical application)
		{	H-spread (post-lexical application)

Such orderings are predicted by a theory of phonology where rule applications are assigned to particular strata, and where a rule can be assigned to more than one stratum. This case of ordering relations is interesting because it could not be accounted for by a notion such as 'local ordering' (Anderson 1974). This is because we are dealing here with the same two rules, ordered in opposite sequences for different cases. Moreover, notions of 'feeding' and 'bleeding' do not account for such cases since Second H-deletion potentially feeds H-spread in both examples being discussed.

To close off this section, I wish to pose a question. If prefixes

Consider the derivation of tùkátóbèlè (73b). On the stem cycle, there is no tone available for association.

(75) a. [tobel]

The problem is that if a suffix with a free H-tone is added to the stem in (75a), the free H should link by left-to-right convention to the first vowel of tobel.

b. * $\left[\left[\begin{array}{l} \text{tobel} \\ \text{H} \end{array} \right] e \right]$

In fact, it links to the second vowel. This can be accounted for if the first vowel of the stem in (75) is not available for tone association. In the next chapter, I argue that precisely such a notion is required for tonal grammars. As in stress systems where certain constituents can be marked 'extrametrical', in tone systems, certain peripheral constituents can be marked 'extratonal'.

Hence the peculiarity of the Remote Dependent Affirmative is a rule that marks the first syllable of a toneless verb stem as extratonal. Hence the correct representation prior to tone association would be as in (76).

(76) a. $\left[\left[\begin{array}{l} \text{to} \text{ bel} \\ [+ex] \end{array} \right] e \right]$

Association conventions will then apply, linking the H to the second vowel of tobel, since the first vowel is unavailable for tone

association.



On the third cycle, the syllable to ceases to be on the periphery of its domain. By the Peripherality Condition discussed in chapter 5, it therefore automatically loses its extratonicity.

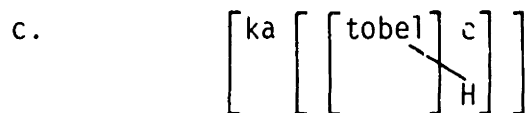

H-spread (25) can now apply:

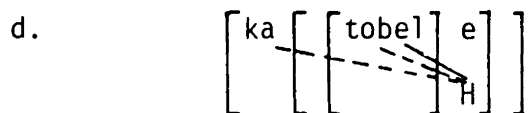

On the last cycle, the association conventions will link the H of tu.

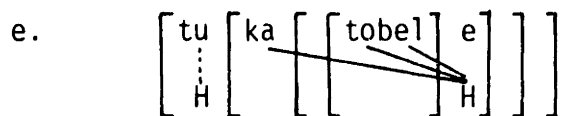

Finally, the regular post-lexical rules will then derive tùkátóbèlè.

The important point about such cases is that there is again no reason to posit special accentual rules. The accentual rule required in the analysis of Goldsmith (1981) needs reference to variables, it shifts an accent, and it changes the nature of the accent that it shifts (from accent to post-accent). Under a tonal analysis, the only

rule required is one that excludes the first stem vowel from consideration. Association of the free H of the final vowel is then by normal association conventions.

8.8 Conclusion

In this section, I have argued at some length that as far as Tonga is concerned, there is no need for the introduction into tonal theory of accentual diacritics. Although many 'accents' in Tonga are shown to be pre-linked H-tones --notably in nouns -- it is also shown that a number of H-tones are underlyingly free, becoming associated by convention. Such cases provide striking support for a tonal analysis of Tonga, since in accentual theory, there is nothing like a 'free' accent that gets linked by left-to-right convention.

In this analysis, only H-tones are present in the lexical derivation; L-tones are introduced post-lexically. It is crucial to the approach taken here that spreading of tones not be automatic, arguing for the restricted set of association conventions discussed in chapter 1. Finally, the facts of the rule of Second H-deletion support the proposal that there is a category of 'word-level' rules.

It should be noted that the idea of treating languages like Tonga as manifesting a H vs. ϕ underlying contrast is not new. Apart from the recent work by Hyman (1982) on Luganda discussed briefly in section 7, Hyman and Valinande (1983) propose such an analysis for Kinande. Moreover, Stevick (1969) proposed that Proto-Bantu should be reconstructed as a one-tone language underlyingly, with the underlying tone being

realized as a high pitch. Toneless vowels would be realized as H if an underlying tone was 'spread' onto them; otherwise they would be realized as L.

FOOTNOTES: CHAPTER 4

1. In the exposition, I generally assume metrical trees. Nothing, however, hinges on this assumption for the points being made.
2. This 'head-marking' property of diacritics was pointed out to me by Morris Halle.
3. In this and a number of similar examples, I beg the question of whether prefixation takes place prior to or after suffixation.
4. I assume that Lowering, H-spread, etc. are formulated on a 'V-projection', that is, they only refer to tones and tone-bearing units.
5. See chapter 1, section 2.4 ; chapter 3, sections 3.4.2 and 5.; and chapter 6, section 7.
6. Note that Delinking must not apply iteratively.
7. In the derivations in (34), I assume that H-spread (25) applies lexically (and cyclically), while Delinking (28) and Default L-insertion (13) apply post-lexically. Why this is the case will become clear later.
8. I assume that H-spread applies cyclically in this case. Also, as part of the lexical derivation, the i of ndi is deleted.
9. For the full set of facts under consideration, see Goldsmith (1981) and references therein.
10. The ordering of this rule with respect to H-spread will be discussed in more detail later.

11. I have not got any evidence to determine whether Recent Past Spread applies lexically or post-lexically.
12. Goldsmith points out that the rule could be sufficiently specified as either:

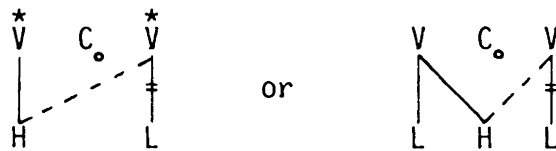

The rising tone on the first vowel would be simplified by a general contour simplification rule. For the purposes of discussion, I assume the fully specified version of the rule.

13. Note that this revision of Second H-deletion has no effect on the cases discussed for the Recent Past (strong) forms (52), since all the H-tones deleted in those examples were linked to a single tone-bearing unit.
14. For a discussion of the complete set of relevant forms, see Goldsmith (1981).

CHAPTER 5: EXTRATONALITY

Recent work on stress systems (eg. Hayes 1980, 1982, Harris 1983) has argued that certain constituents on the periphery of a stress domain should be excluded from consideration when applying stress rules. Such constituents have been labeled "extrametrical" and it has been proposed by Harris that they are subject to the following condition:

- (1) Peripherality Condition:
$$[\overset{X}{+ex}] \rightarrow [-ex] / \text{--- } Y]_D ,$$

where $Y \neq \phi$ and D is the domain of the stress rules.

In this chapter, it will be argued that basically the same notion is applicable in tone systems. That is, a constituent at the edge of a tonal domain may be "invisible" for the purposes of tonal rules. Such constituents, which I will refer to as "extratonal", are subject to a generalized version of the Peripherality Condition. Hence extrametricality and extratinality are subcases of a more general notion of "peripherality".

Extratinality will be demonstrated to play an important role in the analysis of certain cases of tonal polarity -- that is, cases where a particular syllable or morpheme is H adjacent to a L-tone and L adjacent to a H-tone. In the cases of polarity examined here, the notion of extratinality allows an analysis without any morphologically conditioned rules of polarization or dissimilation.

1. Background to Margi

The data for this chapter will be drawn almost entirely from work done by Hoffmann (1963) on Margi, a Chadic language of Nigeria. Some additional discussion of extratonicity is found in chapter 4, section 8.7, where it is suggested that extratonicity plays a role in Tonga verbs, and in chapter 6, it will be shown that extratonicity plays a role in the determination of the Imperative and Subjunctive tenses of Tiv. In this section, I will present certain facts of Margi that will be crucial to understanding the subsequent discussion of extratonicity.

Verbs, nouns, affixes, etc. can be classified according to their tonal properties. In this section, I will be concerned with how verbs of the "L-tone", "H-tone" and "toneless" classes interact with "L-tone", "H-tone" and "toneless" suffixes. Following Williams (1971), I analyse Hoffmann's "changing" tone verbs as inherently toneless, and account for their tonal behaviour in ways that will be outlined below.

The first set of cases to be examined consists of concatenations of stems and suffixes where both stems and suffixes bear lexical tones.

(2) a. H-verb stem and H-suffix

tá	+	bá	→	tábá	'to cook all'
cook					

b. H-verb stem and L-suffix ¹

ná	+	dâ	→	nádâ	'give me'
give		me			

c. L-verb stem and H-suffix

mbù + ngârí → mbùngârí 'to sew on to'
 sew on to

d. L-verb stem and L-suffix ¹

ptsâ + 'yâ → ptsâ'yâ 'roast us'
 roast us

In such cases, the stem tone has no effect on the suffix and suffix tone has no effect on the stem. When we look at lexically toneless stems, however, we see that the surface tone depends on such a stem's tonal environment. For example, if a toneless suffix is added to a H-tone stem, then it too will be H. If, on the other hand, such a suffix is added to a L-tone stem, then the suffix will be L.

(3) H-verb stem and toneless suffix

a. tsá + ri → tsárí 'to knock at'
 beat

b. tá + nya → tányá 'to use all in cooking'
 cook

(4) L-verb and toneless suffix

a. nâ + ri → nâr² 'to tell a person'
 say

b. fâfâ + na → fâfânâ 'to wipe off'
 wipe

Similarly, if a H or L suffix is added to a toneless verb stem, then the resulting complex will bear the tone of the suffix.

(5) Toneless verb stem and H-tone suffix

- a. məl + ía → mǎlíá 'to make (ready)'
 make
- b. ɲəl + bá → ɲǎlbá 'to bite a hole'
 bite

(6) Toneless verb stem and L-tone suffix

- a. hār + dǎ → hǎrdǎ 'bring me'
 bring me
- b. skə + dǎ → skǎdǎ 'wait for me'
 wait me

If we assumed an autosegmental theory such as proposed in Goldsmith (1976) or Clements and Ford (1979), then the tonal facts illustrated in (3 - 6) would be accounted for by assuming that universal conventions spread tones onto abutting toneless vowels. We will see in section 4.5 below, however, that this assumption derives incorrect results in Margi. Consequently, I will continue to assume the universal association conventions are as presented in chapter 1:

- (7) Map a sequence of tones onto a sequence of tone-bearing units,
 a) from left to right, b) in a one-to-one relation.

Any multiple linkings of a single tone to more than one tone-bearing unit, or of a single tone-bearing unit to more than one tone, must be accomplished by language-specific rules.

In Margi, we will see that spreading of tones takes place only from left to right. I therefore propose the following rule:

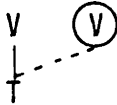
(8) Tone-spreading: 

This rule will apply iteratively from left to right, spreading a tone onto any toneless vowels to its right. In examples like those in (9), rule (8) spreads the lexical tone of the stem onto a toneless suffix. ²

(9) a.	$\left[\begin{array}{c} \text{tsa} \\ \vdots \\ \text{H} \end{array} \right]$	b.	$\left[\begin{array}{c} \text{nə} \\ \vdots \\ \text{L} \end{array} \right]$	Cycle 1: Association Conventions (7)
	$\left[\left[\begin{array}{c} \text{tsa} \\ \vdots \\ \text{H} \end{array} \right] \text{rj} \right]$		$\left[\left[\begin{array}{c} \text{nə} \\ \vdots \\ \text{L} \end{array} \right] \text{rj} \right]$	Cycle 2: Tone-spreading (8)
	tsárí 'to knock at'		nàrí 'to tell a person'	

In the examples of (10), on the other hand, the left-to-right association conventions first apply, to link the tone of the suffix onto the first vowel of the toneless stem. Tone-spreading then spreads the linked tone onto the suffix vowel. Note that such cases do not constitute the spreading of a linked tone from right to left.

(10) a.	$\left[\text{nal} \right]$	b.	$\left[\text{skə} \right]$	Cycle 1
	$\left[\left[\text{nal} \right] \text{ba} \right]$		$\left[\left[\text{skə} \right] \text{da} \right]$	Cycle 2: Association Conventions (7)
	$\left[\left[\text{nal} \right] \text{ba} \right]$		$\left[\left[\text{skə} \right] \text{da} \right]$	Tone-spreading (8)

$\eta\acute{a}lb\acute{a}$ $sk\grave{\partial}\acute{d}\acute{a}$
 'to bite a hole' 'wait for me'

In some tenses, no affixes are added to the verb stem. Consequently, if the verb stem is toneless and any derivational affixes are also toneless, then such a complex has no lexically assigned tone. In such cases, the toneless vowels are assigned L-tone autosegments according to the principles discussed in chapter 3.

- (11) a. $sa \rightarrow sa \rightarrow s\grave{a}$ 'drink!'
- $\begin{array}{c} | \\ L \end{array}$
- b. $hya + ani \rightarrow hya + ani \rightarrow hy\grave{a}n\grave{i}$ 'raise!, wake!'
- $\begin{array}{c} | \\ L \end{array}$ $\begin{array}{c} | \\ L \end{array}$ $\begin{array}{c} | \\ L \end{array}$

2. Suffixed object pronouns

We are now in a position to address the issue of extratonicity. Consider first the following paradigm for the suffixed object pronouns (Hoffmann p. 75):

(12)	Sing.	Dual	Plural
A	1st p.: $-d\acute{a}$	excl.: —	$-y\grave{a}$
		incl.: $-m\grave{a}$	$-m\grave{a}r$
B	2nd p.: $-\eta\upsilon, -(\partial)\eta$ $(-\eta\partial-)$		$-ny\grave{i}$
	3rd p.: $-ny\grave{i}, -(\partial)ny$		$-nd\grave{a}$

The segmental variation observed in the second and third persons singular will not be discussed here. Of interest, however, is the

- (14) a. 2nd person sing. object: ~ $\begin{array}{c} \text{ny} \\ [+ex] \end{array}$]
- b. 3rd person sing. object: - $\begin{array}{c} \text{nyi} \\ [+ex] \end{array}$]

In (13b), Tone-spreading (8) is inapplicable because nyi is extratonal -- that is, nyi is invisible with respect to the tone rules. In (13a), on the other hand, nyi is immediately followed by another suffix. Hence by the Peripherality Condition (1), the [+ex] marking of nyi will be changed to [-ex]. As a result of this change, nyi becomes visible to the tone rules and Tone-spreading (8) applies, linking the H of l`àbá' onto nyi. Note that such examples show that the Peripherality Condition must apply prior to the application of Tone-spreading (8).

In the stress examples that have been used to motivate the Peripherality Condition, it has been shown that the Condition applies cyclically -- that is, as soon as a morpheme causes an extrametrical constituent to be non-peripheral, such a constituent ceases to be extrametrical. In Margi, the association conventions (7) and Tone-spreading (8) must apply cyclically. Consider the derivation of a word such as dzà'ùbá 'to pound well'. On the stem cycle, the lexical L is linked to the first vowel by the normal association conventions:

- (15) a. $\begin{array}{c} [dza'u] \\ \vdots \\ L \end{array}$

Tone-spreading (8) will then apply to give:



Then on the second cycle, the suffix ba is added, and the association conventions apply to link the H of the suffix:



Cyclic tone association, in conjunction with cyclic application of Tone-spreading (8), correctly derives dzà'ùbá. If, on the other hand, the association conventions and tonal rules were to apply non-cyclically, then we would obtain the wrong results in such a case:

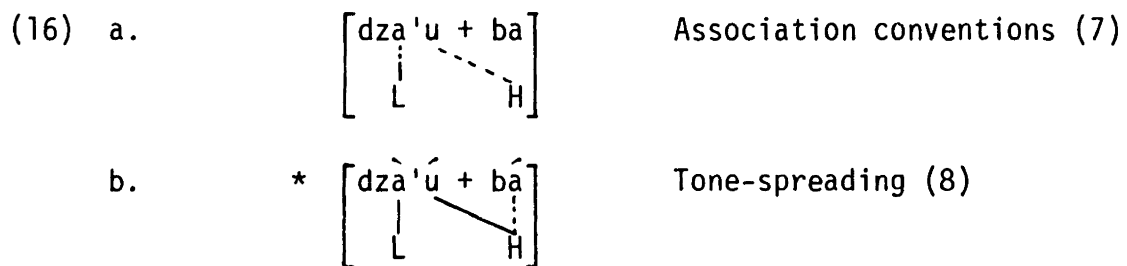

Since the rule of Tone-spreading (8) applies cyclically, and since the Peripherality Condition must apply prior to Tone-spreading, the Peripherality Condition must apply cyclically in tonal derivations just as it does for stress.

With this in mind, consider now the example in (17).

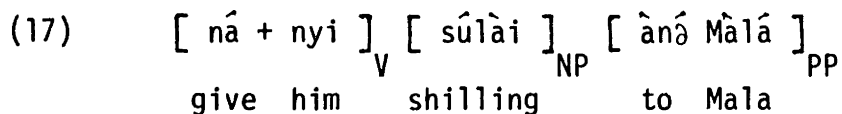

The output of (17) is nányí sùlài ànâ Málá 'give Mala a shilling'. What is interesting about this case is that nyi is H even though it is word-final. This means that Tone-spreading must have taken place, spreading the H of ná onto nyi. But we know that Tone-spreading could not have applied cyclically in the derivation of nányí since nyi is extratonal. (Note example (13b)) The solution to this problem is straightforward if we simply assume that Tone-spreading and the Peripherality condition both apply post-lexically at the phrasal level, in addition to their lexical application during the derivation of words. Where the domain D of the Peripherality Condition (1) is the phrase, nyi retains its extratonicity in (13b) but loses it in (17). Hence Tone-spreading (8) is applicable in (17) but inapplicable in (13).

3. Genitive constructions

In Margi, genitive constructions are basically of the form $\left[\begin{array}{c} N + X \text{ NP} \\ \text{NP} \end{array} \right]$, where N = head noun, X = ϕ or genitive marker, and NP = qualifying NP. Choice of genitive marker (position X) determines differences between inalienable possession, ordinary possession, etc.

Of interest to the present discussion is a form of the "short r-possessive construction" where singular object pronouns are suffixed directly to the head NP -- as illustrated in (18).

- | | | | | |
|------|---------|--------------|----------|---------------------|
| (18) | mwáí | 'friend' | sàlkù | 'father-in-law' |
| | mwáldà | 'my friend' | sàlkùdà | 'my father-in-law' |
| | mwáínyî | 'his friend' | sàlkùnyî | 'his father-in-law' |

The tonal behaviour of such singular pronouns in this construction is the same as observed for second and third person singular object pronouns when suffixed to a verb. In phrase-final position, as in (18) above, they bear a L-tone. In non-phrase-final position, however, the pronoun will bear the tone of the preceding syllable -- a fact that can be explained by marking the suffixes in question as extratonal. Consider the sample derivations below: ³

- (19) a.
- | | | | |
|--|---|--|--------------------------------|
| $\left[\begin{array}{c} \text{zam} + \text{d}\acute{\text{a}} \\ \\ \text{L} \end{array} \right]$ | $\left[\begin{array}{c} \text{d}\acute{\text{a}} \\ [+ex] \end{array} \right]$ | $\left[\begin{array}{c} \text{'yar} \\ \\ \text{L} \end{array} \right]$ | |
| brother | my | plural | |
| $\left[\begin{array}{c} \text{zam} + \text{d}\acute{\text{a}} \\ \\ \text{L} \end{array} \right]$ | $\left[\begin{array}{c} \text{d}\acute{\text{a}} \\ [-ex] \end{array} \right]$ | $\left[\begin{array}{c} \text{'yar} \\ \\ \text{L} \end{array} \right]$ | Peripherality Condition
(1) |
| $\left[\begin{array}{c} \text{zam} + \text{d}\acute{\text{a}} \\ \\ \text{L} \end{array} \right]$ | $\left[\begin{array}{c} \text{'yar} \\ \\ \text{L} \end{array} \right]$ | | Tone-spreading (8) |
| $\text{z}\grave{\text{a}}\text{m}\text{d}\grave{\text{a}} \text{'y}\grave{\text{a}}\text{r}$ | | | 'my brothers' |
- b.
- | | | | |
|---|---|--|--------------------------------|
| $\left[\begin{array}{c} \text{\eta wam} + \text{d}\acute{\text{a}} \\ \\ \text{H} \end{array} \right]$ | $\left[\begin{array}{c} \text{d}\acute{\text{a}} \\ [+ex] \end{array} \right]$ | $\left[\begin{array}{c} \text{'yar} \\ \\ \text{L} \end{array} \right]$ | |
| sister | my | plural | |
| $\left[\begin{array}{c} \text{\eta wam} + \text{d}\acute{\text{a}} \\ \\ \text{H} \end{array} \right]$ | $\left[\begin{array}{c} \text{d}\acute{\text{a}} \\ [-ex] \end{array} \right]$ | $\left[\begin{array}{c} \text{'yar} \\ \\ \text{L} \end{array} \right]$ | Peripherality Condition
(1) |
| $\left[\begin{array}{c} \text{\eta wam} + \text{d}\acute{\text{a}} \\ \\ \text{H} \end{array} \right]$ | $\left[\begin{array}{c} \text{'yar} \\ \\ \text{L} \end{array} \right]$ | | Tone-spreading (8) |
| $\text{\eta w}\acute{\text{a}}\text{m}\text{d}\acute{\text{a}} \text{'y}\grave{\text{a}}\text{r}$ | | | 'my sisters' |

At the phrase level, dá loses its extratonicity because it is not at the edge of its phrasal domain. Consequently Tone-spreading applies and we correctly derive the forms in (19a) and (19b).

In summary, we have seen two constructions in Margi where the notion of extratonicity explains in a straightforward manner a number of interesting tonal alternations. When a syllable remains extratonic up to the phrasal level, it is assigned a L-tone by the default rules. If, however, it loses its extratonicity by virtue of being non-peripheral, then the rule of Tone-spreading applies, assigning it the tone of the syllable to its left.

A possible alternative to the extratonicity approach would be to assume a rule of phrase-final lowering or delinking for such cases. For such an analysis to work, however, it would be necessary to allow phrase-level rules to be sensitive to the internal morphological structure of a word, since only certain morphemes could be allowed to trigger the rule. This means either of two things: 1) the principle of bracket erasure would be violated, by allowing a post-lexical rule to refer to morphological properties, or 2) one would allow post-lexical rules to make reference to 'syntactic' information that plays no role in the syntax of the language in question -- in Margi, a language without syntactic agreement, this means referring to features like 'first person singular' at the phrasal level although there is no syntactic evidence for so doing.

4. Polarity

4.1 Present tense

Hoffmann observes (p.190) that "the present tense is characterized by an a- which is prefixed to the verb stem... The prefix a- has contrast tone, ie. it is high, if the first syllable of the verb is low or rising, but it is low, if the first syllable of the verb is high". In (20), I give examples with L and H verbs.

- (20) a. wì 'to run' áwì yú 'I run'
 b. sá 'to err' àsá yú 'I err'

4.2 Past tense

Before proposing an analysis for the present tense cases, it is interesting to note that there is also polarization in the past tense. Like the present tense, the past is characterized by an a- prefix, but in addition, the past tense has a L-tone suffix -(ə)rì, whose non-final form is -(ə)r. The verb stems in (20) will appear in the past tense as follows:

- (21) a. áwìr yú 'I ran'
 b. àsár yú 'I erred'

Note that the polarizing behaviour observed in the past and present tenses is not a general feature attested in the formation of tenses in Margi. For example, to form the Narrative tense, a prefix gà is attached to the verb and this prefix always bears a L-tone. ⁴

- (22) a. nì gà wì 'I ran'
 b. nì gà sá 'I erred'

The occurrence of polarization in two tenses where there is an a-prefix can only be explained by assigning the polarization property to the a-morpheme. In other words, polarity in Margi appears to be morphologically triggered -- not syntactically triggered by certain tenses.

4.3 Subject clitics

The forms of what Hoffmann calls the "suffixed subject pronouns" are given in (23):

(23)	Sing.	Dual	Plural
1st p.:	yú (yí)	excl.: — incl.: ma	'ya mār
2nd p.:	gụ (gə)		nyi
3rd p.:	já		nda

The parenthesized forms in (23) are those that occur in non-final position, when such a form is different than the form that occurs in final position. For subject clitics, the tone of the first and third persons singular is always H; but for all other persons, the tone of the clitic polarizes with respect to the preceding syllable. Hence if the preceding syllable is H, then the clitic is L, and if the preceding syllable is L, then the clitic is H.

Subject clitics support the observation made in the previous section that polarity is a property of morphemes. It is not all subject clitics that polarize, but only specific morphemes.

Examples of polarization involving subject clitics are given below:

- (24) a. áwì ndá 'they run'
 H̀̀gyì gù 'you are a Higi'
 b. àsá ndà 'they err'
 M̀̀rgyí gù 'you are a Margi'

Whereas the suffixed object discussed earlier (section 2.) attaches only to verb stems, the 'suffixed subjects' attach to a variety of categorial types. In (24), for example, we have examples of subject clitics with verbs and with predicative nouns. Cases where clitics are attached to predicative adverbs are given in (25).

- (25) àdà já 'he is up'
 àbá já 'he is outside'
 ív̀̀à já 'he is at home'

It is also possible to attach subject clitics to certain interrogatives:

- (26) àbár ndà 'how are they?'
 úmwár ndà rá? 'where are they?'

Lastly, the 'suffixed subjects' can attach to a complementizer such as d̀̀à, which introduces both main and subordinate clauses.

- (27) a. d í gà hâr kâmár 'then I was patient'
 b. sâtá dá gè gà kùdn(à) ùzà ... 'when you have finished hoeing ...'

Although Hoffmann notes that there are restrictions on the types of predicates that these subject pronouns can attach to, it nevertheless seems that the basic defining property of the categories that they attach to (complementizers aside) is that they are syntactic predicates. The fact that the categories to which suffixed subjects attach is definable syntactically, and not morphologically, argues that clitics are introduced in the syntax and not in the lexicon.

If subject clitics are attached at the syntactic level, another fact is explained. Suffixed subjects come outside of all derivational and inflectional morphology, unlike object suffixes that can occur inside certain tense morphemes. By assigning subject cliticization to the syntax, this automatically orders it after all morphological processes of derivation and inflection.

4.4 Analysis

All of the above cases of polarization can be accounted for in a straightforward way if we assume that the polarizing morphemes have the following underlying representation:

(28)
$$\begin{bmatrix} \sigma \\ [+ex] \\ H \end{bmatrix}$$

Such morphemes include a H-tone but are lexically marked as extratonal. Consider first the case of the polarizing subject clitics. Subjects in Margi are generated in a position before the predicate. I assume therefore that the post-predicate position of the subject clitics is derived by a rule of cliticization such as the following:

(29) Subject Cliticization:

$$\left[\begin{array}{c} \text{SCL} \\ \text{X}^0 \end{array} \right] \left[\begin{array}{c} \text{Y} \\ \text{X}^0 \end{array} \right] \rightarrow \left[\begin{array}{c} \bar{\text{X}} \\ \text{X}^0 \end{array} \right] \left[\begin{array}{c} \text{Y} \\ \text{X}^0 \end{array} \right] \left[\begin{array}{c} \text{SCL} \\ \text{X}^0 \end{array} \right]$$

Consider the following examples, shown in the configuration that results from Subject Cliticization.

(30) a. $\left[\begin{array}{c} \left[\begin{array}{c} \text{margyi} \\ | \quad | \\ \text{L} \quad \text{H} \end{array} \right] \left[\begin{array}{c} \text{gu} \\ [+ex] \\ \text{H} \end{array} \right] \\ \bar{\text{X}} \quad \text{X}^0 \end{array} \right]$ b. $\left[\begin{array}{c} \left[\begin{array}{c} \text{h\`agyi} \\ | \quad | \\ \text{L} \quad \text{L} \end{array} \right] \left[\begin{array}{c} \text{gu} \\ [+ex] \\ \text{H} \end{array} \right] \\ \bar{\text{X}} \quad \text{X}^0 \end{array} \right]$

m\`argy\`i gu h\`agyi gu
'you are a Margi' 'you are a Higi'

I will derive these forms by positing a general rule that deletes floating H-tones next to a H-tone:

(31) Floating H-deletion: $\textcircled{\text{H}} \rightarrow \phi / \text{H}$

In the cases of (30), Floating H-deletion will apply to (30a) but will not apply to (30b):

(32) a. $\left[\begin{array}{c} \left[\begin{array}{c} \text{margyi} \\ | \quad | \\ \text{L} \quad \text{H} \end{array} \right] \left[\begin{array}{c} \text{gu} \\ [+ex] \\ \phi \end{array} \right] \\ \bar{\text{X}} \quad \text{X}^0 \end{array} \right]$ b. $\left[\begin{array}{c} \left[\begin{array}{c} \text{h\`agyi} \\ | \quad | \\ \text{L} \quad \text{L} \end{array} \right] \left[\begin{array}{c} \text{gu} \\ [+ex] \\ \text{H} \end{array} \right] \\ \bar{\text{X}} \quad \text{X}^0 \end{array} \right]$

y surfaces with a default L-tone.

$$(34) \quad \begin{array}{c} \text{H} \\ \text{k}\hat{\text{a}}\text{r} \end{array} + \begin{array}{c} \text{H} \\ \text{a} \end{array} \quad \begin{array}{c} \text{H} \\ \text{y}\hat{\text{u}} \\ [+ex] \end{array} \quad \rightarrow \quad \text{k}\hat{\text{a}}\text{r}\hat{\text{a}}\text{y}\hat{\text{u}} \quad \text{'my head'}$$

Moreover, in such genitive constructions, there is strong evidence that the attested polarity involves extratonicity. If a demonstrative follows the sequence in (34) -- which has already undergone cliticization and Floating H-deletion -- then the morpheme y will lose its extratonicity by virtue of the Peripherality Condition. As a result, Tone-spreading (8) will apply, and y will receive the tone of the preceding syllable.

$$(35) \quad \text{a.} \quad \begin{array}{c} \left[\begin{array}{c} \left[\begin{array}{c} \text{k}\hat{\text{a}}\text{r} + \text{a} \\ \text{H} \quad \text{H} \end{array} \right] \left[\begin{array}{c} \text{y}\hat{\text{u}} \\ [+ex] \end{array} \right] \right] \left[\begin{array}{c} \text{ku} \\ \text{L} \end{array} \right] \\ \alpha \end{array} \\ \text{b.} \quad \begin{array}{c} \left[\begin{array}{c} \left[\begin{array}{c} \text{k}\hat{\text{a}}\text{r} + \text{a} \\ \text{H} \quad \text{H} \end{array} \right] \left[\begin{array}{c} \text{y}\hat{\text{u}} \\ \text{---} \end{array} \right] \right] \left[\begin{array}{c} \text{ku} \\ \text{L} \end{array} \right] \\ \alpha \end{array} \end{array}$$

After the rule that affects the vowel quality of the y in y, we therefore end up with káráyí kù 'this my head'.

Since the special property of the first and third person singular clitics cannot be simply the absence of extratonicity, I suggest that the key to their behaviour lies in the nature of α in the representation in (35). I propose that when these two pronouns are cliticized, the result is an X^0 and not an \bar{X} . Underlyingly, y and ja will have the same representation as other subject clitics, ie. the representation shown in (28). But these two pronouns will

undergo a special rule of cliticization:

(36) Subject Cliticization (1st & 3rd persons singular): ⁵

$$[_{X^0} \text{SCL 1\&3}] [_{X^0} Y] \rightarrow [_{X^0} [_{X^0} Y] [_{X^0} \text{SCL 1\&3}]]$$

By analysing the output of the special rule of cliticization as being an X^0 (rule 36), and the output of the general rule as being an \bar{X} (rule 29), it is possible to account for a number of differences between the two sets of clitics. First, I propose that the process of cliticization in Margi involves looping the derived constituent back into the lexicon (Note Mohanan 1982). That is, the constituent that is derived by the syntactic rule of cliticization is sent to the lexicon, where any relevant phonological rules will then apply.

(37)

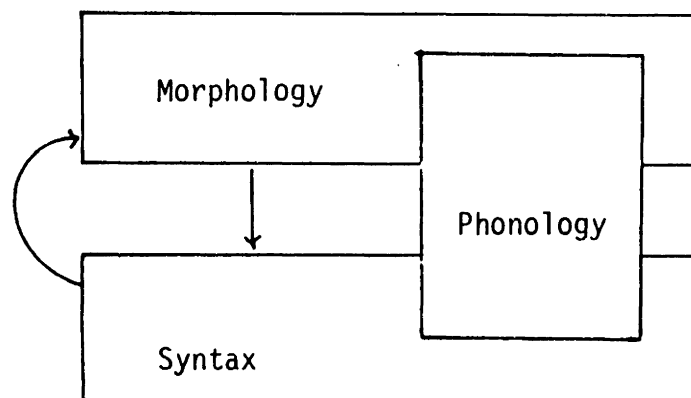

I suggest further that the rule of Tone-spreading (8) is restricted to applying within the domain of X^0 . This means that Tone-spreading will potentially apply between the two component constituents of the X^0 created by the cliticization rule in (36), whereas it will not apply between the two constituents that make up the \bar{X} that results from the rule in (29).

Finally, I assume that the rule of Floating H-deletion (31) applies lexically.

Let us now consider the different effects of the two cliticization rules.⁶ When the clitic occurs in phrase-final position as the subject of a noun phrase, we observe the following:

$$(38) \quad \text{a. } \left[\bar{X} \left[\begin{array}{cc} [k\partial r + a] \\ | \quad | \\ H \quad H \end{array} \right] \left[\begin{array}{c} gu \\ [+ex] \\ H \end{array} \right] \right] \quad \text{b. } \left[X^0 \left[\begin{array}{cc} [k\partial r + a] \\ | \quad | \\ H \quad H \end{array} \right] \left[\begin{array}{c} ja \\ [+ex] \\ H \end{array} \right] \right]$$

The rule of cliticization in (29) creates the configuration in (38a) -- the \bar{X} case -- while the rule in (36) creates the configuration in (38b) -- the X^0 case. By assuming that Floating H-deletion applies both at the domain of \bar{X} and X^0 , we predict its application in both (38a) and (38b):

$$(39) \quad \text{a. } \left[\bar{X} \left[\begin{array}{cc} [k\partial r + a] \\ | \quad | \\ H \quad H \end{array} \right] \left[\begin{array}{c} gu \\ [+ex] \\ \phi \end{array} \right] \right] \quad \text{b. } \left[X^0 \left[\begin{array}{cc} [k\partial r + a] \\ | \quad | \\ H \quad H \end{array} \right] \left[\begin{array}{c} ja \\ [+ex] \\ \phi \end{array} \right] \right]$$

In phrase-final position, the morphemes gu and ja will retain their extratonicity since they are at the periphery of the phrasal domain. As a result Tone-spreading will be unable to apply, and the two morphemes will ultimately get L-tones by default, resulting in kárágù 'your head' and kárájà 'his head'. Hence in phrase-final position in noun phrases, the two cliticization rules have the same effect.

Consider what happens, however, if the configurations shown in (39) occur in a non-phrase-final position. In the case of \bar{X} cliticization, the clitic will surface on a L-tone -- as in phrase-final position: kārágà kù 'this your head'. With the X^0 clitics, on the other hand, the clitic will surface on a H-tone: kárájá kù 'this his head'. Both of these facts follow automatically from the assumption that Tone-spreading applies only within the domain of X^0 . Consider first the case of \bar{X} cliticization:

$$(40) \quad \left[\bar{X} \left[X^0 \begin{array}{c} k\partial r + a \\ | \quad | \\ H \quad H \end{array} \right] \left[X^0 \begin{array}{c} g\underset{\cdot}{u} \\ [+ex] \end{array} \right] \right] \left[X^0 \begin{array}{c} ku \\ | \\ L \end{array} \right]$$

The result of cliticization in such a case was seen above in (39a). The effect of adding a demonstrative such as kù at the phrasal level is to make the clitic non-peripheral. Because of this, the Peripherality Condition (1) will remove the extratonicity of gù. Tone-spreading (8) is not applicable in such a case, because its domain is restricted to X^0 . And the only place where Tone-spreading would be potentially applicable in (40) is between two X^0 constituents of an \bar{X} . So the clitic in a case like (40) will get a L-tone by default and we end up with kārágà kù.

Turning to the case of X^0 cliticization, the situation is quite different.

$$(41) \quad \left[X^0 \left[X^0 \begin{array}{c} k\partial r + a \\ | \quad | \\ H \quad H \end{array} \right] \left[X^0 \begin{array}{c} ja \\ [+ex] \end{array} \right] \right] \left[X^0 \begin{array}{c} ku \\ | \\ L \end{array} \right]$$

Just as in (40), the Peripherality Condition (1) will apply to remove the extratonicity of the clitic. Unlike (40), however, Tone-spreading (8) is applicable since the X + CL constituent is an X⁰:

- (42) a.
$$\left[\begin{array}{c} \left[\begin{array}{c} k\bar{a}r + a \\ | \\ H \end{array} \right] \left[\begin{array}{c} ja \\ | \\ [-ex] \end{array} \right] \\ \left[\begin{array}{c} X^0 \\ | \\ X^0 \end{array} \right] \end{array} \right] \left[\begin{array}{c} ku \\ | \\ L \\ \left[\begin{array}{c} X^0 \end{array} \right] \end{array} \right] \quad \text{Peripherality Condition (1)}$$
- b.
$$\left[\begin{array}{c} \left[\begin{array}{c} k\bar{a}r + a \\ | \\ H \end{array} \right] \left[\begin{array}{c} ja \\ | \\ H \end{array} \right] \\ \left[\begin{array}{c} X^0 \\ | \\ X^0 \end{array} \right] \end{array} \right] \left[\begin{array}{c} ja \\ | \\ X^0 \end{array} \right] \left[\begin{array}{c} ku \\ | \\ L \\ \left[\begin{array}{c} X^0 \end{array} \right] \end{array} \right] \quad \text{Tone-spreading (8)}$$

The result of Tone-spreading is the surface form kārājá kù.

By assuming that the output of the general cliticization rule is an \bar{X} , and by assuming that the output of the special cliticization rule for first and third persons singular is an X⁰, we can account for the tonal behaviour of clitics in noun phrases, both in phrase-final and non-phrase-final position. Concerning the subject clitic of an S, we would predict the same set of facts as in an NP. For the \bar{X} clitics, we would predict L-tones to be assigned by default in both phrase-final and non-phrase-final position (still restricting our attention to heads with final H-tones). This prediction is correct.

- (43) a. phrase-final:
$$\left[\begin{array}{c} \bar{X} \\ | \\ X^0 \end{array} \right] \left[\begin{array}{c} m\bar{a}r\bar{g}y\bar{i} \\ | \\ X^0 \end{array} \right] \left[\begin{array}{c} nd\bar{a} \\ | \\ X^0 \end{array} \right]]$$

'they are Margis'
- b. non-phrase-final:
$$\left[\begin{array}{c} \bar{X} \\ | \\ X^0 \end{array} \right] \left[\begin{array}{c} \acute{u}m\bar{w}\bar{a}r \\ | \\ X^0 \end{array} \right] \left[\begin{array}{c} nd\bar{a} \\ | \\ X^0 \end{array} \right]] \left[\begin{array}{c} r\bar{a} \\ | \\ X^0 \end{array} \right]$$

'where are they?'

lexically. This suggests that when the $\left[\begin{array}{c} _ \\ X \end{array} \left[\begin{array}{c} X \\ X^0 \end{array} \right] \left[\begin{array}{c} CL \\ X^0 \end{array} \right] \right]$ constituent leaves the lexicon, its brackets must not be erased. These facts support Simpson's (1983) claim that bracket erasure in the lexicon is restricted to within X^0 constituents.

To summarize, polarity in subject clitics results from a combination of factors. When extratonicity prevents the \underline{H} of a subject clitic from associating, then the \underline{H} will delete or not delete depending on the tonal context. If the \underline{H} deletes, then in phrase-final position, the clitic will get a \underline{L} by default. Hence such clitics surface as \underline{H} or \underline{L} depending on their tonal context. In non-phrase-final position, the situation is rendered more complex since, after triggering Floating H-deletion, the extratonicity of the clitic is lost. Tone-spreading in such cases will be applicable if the $X + CL$ constituent forms an X^0 -- the case of the first and third persons singular. The case of the first and third persons singular is also special in that they lose their extratonicity when attached to the head of an S.

4.5 Present and past tenses (again)

The approach to polarity taken for subject clitics also applies to the \underline{a} - morpheme of the present and past tenses. I assume that this morpheme is represented as in (47):

$$(47) \quad \left[\begin{array}{c} a \\ [+εx] \\ H \end{array} \right]$$

When this morpheme is attached to L and H tone verbs, then we obtain configurations like in (48) for áwî 'runs' and àsá 'errs':

$$(48) \text{ a. } \left[\begin{array}{c} a \\ [+ex] \\ H \end{array} \left[\begin{array}{c} wi \\ | \\ L \end{array} \right] \right] \quad \text{b. } \left[\begin{array}{c} a \\ [+ex] \\ H \end{array} \left[\begin{array}{c} sa \\ | \\ H \end{array} \right] \right]$$

In (48a), Floating H-deletion is not applicable; so when extratonicity is lost, prior to phonetic implementation, the H will link correctly deriving áwî. Floating H-deletion (31) is applicable, however, in (48b); hence when extratonicity is lost, a default L-tone will be assigned, deriving àsá.

This analysis requires that the Peripherality Condition be reformulated to allow extratonicity at both right and left edges of a domain, as shown in (49).

(49) Peripherality Condition (revised):

$$\overset{X}{[+ex]} \rightarrow [-ex] / \left[\begin{array}{c} Y \quad _ \quad Z \\ D \end{array} \right], \text{ where } Y \neq \phi$$

and $Z \neq \phi$, and D is the domain of the stress/tone rules.

The above approach makes an immediate prediction concerning the form that should result in the present and past tenses of a toneless verb stem. Consider (50). Since the H of the prefix cannot link to the a- prefix, it should automatically link to the verb stem by normal left-to-right conventions.

$$(50) \left[\begin{array}{c} a \\ [+ex] \\ H \end{array} \left[\begin{array}{c} (C) V \dots \end{array} \right] \right]$$

Since the prefix vowel has no associated tone, it should therefore be assigned a L by default, and we predict a L H surface pattern. This turns out to be exactly the results that Margi requires:

- (51) a. $\left[\begin{array}{c} a \\ [+ex] \\ H \end{array} \left\{ \begin{array}{c} sa \\ \end{array} \right. \right] \rightarrow \grave{a}s\acute{a} \text{ 'drink (present)'}$
- b. $\left[\begin{array}{c} a \\ [+ex] \\ H \end{array} \left\{ \begin{array}{c} h\grave{a}r \\ \end{array} \right. \right] \rightarrow \grave{a}h\acute{a}r \text{ 'take (present)'}$

4.6 Dissimilation and polarization rules

As a first point concerning alternative approaches to the polarity phenomena of Margi, it should be stressed that cases such as those in (51) fall out automatically from the approach taken in this chapter. An account that creates polarity by means of a rule of polarization or dissimilation would have no obvious explanation for such cases.

Nevertheless, I will consider briefly what such accounts would require. Consider first a possible rule of 'polarization':

- (52) Polarization: $\textcircled{V} \rightarrow \begin{array}{c} V \\ | \\ -\alpha H \end{array} / \left[\begin{array}{c} \text{---} \\ | \\ Q \end{array} \begin{array}{c} V \\ | \\ \alpha H \end{array} \right]$

Under this approach, one would assume that polarizing morphemes are underlyingly toneless, and that their tone is assigned by the rule in (52). Although there are a number of problems inherent in such

an approach, the most crucial point is simply that such rules are ruled out by the theory of underspecification proposed in chapter 3. In chapter 3, it was proposed that a rule may not refer to $[\alpha F]$ in its structural description before a default rule applies to assign $[\alpha F]$. What this means is that an alpha rule like that in (52) cannot apply prior to the assignment of default values, since the α in its structural description includes the value assigned by tonal default rules. That is, an alpha rule could function to change feature values according to the theory of underspecification presented in this thesis, but it could not function to fill in values. This case is an illustration of the fact that by constraining the possible uses of underspecification, the theory narrows down the number of possible analyses of phenomena like polarity.

Let us turn to a dissimilation approach. Two possible rules present themselves:

- (53) Dissimilation: a. $L \rightarrow H \text{ \% } [\underset{Q}{\text{---}}] L$
 b. $H \rightarrow L \text{ \% } [\underset{Q}{\text{---}}] H$

Under the approach in (53a), we would assume that the polarizing morphemes are underlyingly L, while in (53b), we assume that the polarizing morphemes are underlyingly H. First of all, neither of these two rules could apply in an unconditioned way. Consider, for example, the L + L sequence seen in (2d) and the H + H sequence in (2a). Hence it is crucial for such an approach that the "Q" in the

5. Association conventions

Typically, derivational and inflectional suffixes are of two types: 1) toneless 2) H-toned. H-toned suffixes are always H (see examples (2a), (2c) and (5) above), while toneless suffixes will be H after a H-tone syllable and L after a L-tone syllable (see examples (3) and (4) above). In some special cases, it is also necessary to mark a suffix with a L. For example, the plural Imperative is indicated by the following suffix: ⁷

(55) amu
 |
 L

The first vowel -- which is underlyingly toneless -- assumes the tone of the preceding syllable, but the second tone is always L.

(56) a. fál fálámù 'dance! sg. & pl.'
 b. wì wìámù 'run! sg. & pl.'

On the face of it, this set of tonal patterns for suffixes is quite different than that for prefixes. With prefixes, one finds prefixes bearing H-tones, and prefixes bearing L-tones -- but no prefixes that are H before a H-tone syllable and L before a L-tone syllable.

(57) H-toned prefix

a. ská + wì 'lest (I) run (Exclusive II)'
b. ská + sá 'lest (I) go astray (Exclusive II)'

(58) L-toned prefix

- a. gâ + wî 'ran (Narrative)'
 b. gâ + sâ 'erred (Narrative)'

In a theory that assumes automatic bidirectional spreading of tones, this difference between prefixes and suffixes is a curious asymmetry. There is no reason in such a theory not to expect toneless prefixes, and one would expect toneless prefixes to behave in a manner comparable to toneless suffixes -- that is, their tone would be assigned as a function of the tone of adjacent syllables.

In a theory where spreading of tones is only by rule, this asymmetry disappears. Given the rule of Tone-spreading (8), we would expect a toneless suffix to be assigned the tone of the syllable to its left; but since there is no rule spreading tones from right to left, toneless prefixes will end up getting a L by default.

- (59) a. Toneless suffix: $\left[\left[\begin{array}{c} V \\ | \\ T \end{array} \right] V \right] \xrightarrow{(8)} \left[\left[\begin{array}{c} V \\ | \\ T \end{array} \right] \overset{V}{-} \right]$
- b. Toneless prefix: $\left[V \left[\begin{array}{c} V \\ | \\ T \end{array} \right] \right] \rightarrow \left[\begin{array}{c} V \\ | \\ L \end{array} \left[\begin{array}{c} V \\ | \\ T \end{array} \right] \right]$

Hence the same underlying possibilities are attested for prefixes and suffixes. The surface asymmetry is the result of the application of a rightward tone-spreading rule. Notice, moreover, that as with suffixes, the typical pattern for prefixes in this approach is to be either H or toneless, although L-tones are required in a tense like

the Progressive:

- (60) a. $\begin{array}{c} \grave{a}v\grave{a}r + wi \\ \text{H} \quad \text{L} \quad \quad \text{L} \end{array} \rightarrow \hat{a}\hat{v}\hat{a}r \hat{w}\hat{i} \quad \text{'am running (Progressive)'} \\$
- b. $\begin{array}{c} \grave{a}v\grave{a}r + sa \\ \text{H} \quad \text{L} \quad \quad \text{L} \end{array} \rightarrow \hat{a}\hat{v}\hat{a}r \hat{s}\hat{a} \quad \text{'am erring (Progressive)'} \\$

A strong argument for this approach to the association conventions comes from considering cases of toneless stems in the present tense. It was seen in (51a) that the H of the present tense prefix links to the stem in a case like àsá 'drink (Present)', and the prefix gets a L by default:

- (61) $\left[\begin{array}{c} a \\ [+ex] \\ \acute{H} \end{array} \left[\begin{array}{c} sa \end{array} \right] \right]$

If such a verbal complex is preceded by a noun, then the prefix will automatically lose its extratonicity by the Peripherality Condition (1). In such a case, if tone-spreading were bidirectional and automatic, then we would expect the prefix to get a H-tone by spreading of the 'stem' tone; if spreading is only by rule, however, then we correctly predict that such cases will surface with a default L-tone, since there is no rule in Margi to spread tones from right to left.⁸ Consider the post-lexical derivation of the phrase nì àsá 'I drink', where the lexical derivation of the verb was illustrated in (61).

- (62) a. $\left[\begin{array}{c} ni \\ | \\ L \end{array} \right] \left[\begin{array}{cc} a & sa \\ [+ex] & | \\ & H \end{array} \right]$
- b. $\left[\begin{array}{c} ni \\ | \\ L \end{array} \right] \left[\begin{array}{cc} a & sa \\ [-ex] & | \\ & H \end{array} \right]$ Peripherality Condition (1)
- c. $\left[\begin{array}{c} ni \\ | \\ L \end{array} \right] \left[\begin{array}{cc} a & sa \\ | & | \\ L & H \end{array} \right]$ Default L-insertion

The above arguments for having only rule-governed spreading of tones in Margi are interesting because of the wide-spread occurrence of rightward spreading. The frequency of rightward tone spreading led to the proposal of automatic spreading in work such as that of Williams (1971). But we see that even in Margi -- where spreading is so common -- the assumption of automatic spreading would lead us to a number of problems.

6. The cycle

It was seen in section 2 above that tone association and tonal rules like Tone-spreading (8) apply cyclically in Margi. A word like dza'ùbá 'to pound well' is derived as in (63) and not as in (64).

- (63) $\left[\begin{array}{c} dza'u \\ | \\ L \end{array} \right]$ Cycle 1: Association Conventions (7)
- $\left[\begin{array}{c} dza'u \\ | \\ L \end{array} \right]$ Tone-spreading (8)

$$\left[\left[\begin{array}{c} \text{dza}'\text{u} \\ \swarrow \\ \text{L} \end{array} \right] \text{ba} \right] \quad \text{Cycle 2: Association Conventions} \\ (7)$$

$$(64) \quad \left[\begin{array}{c} \text{dza}'\text{u} + \text{ba} \\ \vdots \quad \text{---} \\ \text{L} \quad \quad \text{H} \end{array} \right] \quad \text{Association Conventions (non-cyclic)} \\ (7)$$

$$\left[\begin{array}{c} \text{dza}'\text{u} + \text{ba} \\ \vdots \quad \text{---} \\ \text{L} \quad \quad \text{H} \end{array} \right] \quad \text{Tone-spreading (8)}$$

One might suggest, however, that the correct surface form could be derived non-cyclically by pre-linking the L of dza'û to the second vowel:

$$(65) \quad \begin{array}{c} \text{dza}'\text{u} \\ | \\ \text{L} \end{array}$$

While such a representation could be used in correctly deriving dza'ûbá, it would make the incorrect prediction -- as far as I know -- that some disyllabic stems would have a H-tone on the first mora in the past or present tenses. That is, a pre-linking approach would predict cases like that shown in (66).

$$(66) \quad \left[\begin{array}{c} \text{a} \\ [+ex] \\ \text{H} \end{array} \right] \left[\begin{array}{c} \text{C} \text{V} \text{C} \text{V} \\ \text{---} \\ \text{L} \end{array} \right] \rightarrow \text{`aC'CV}$$

Since such cases do not exist, a pre-linking approach would have to completely link a stem like dza'û in a non-cyclic analysis.

(67) dza'u
 ↙
 L

But pre-linked representations like those in (65) and (67) fail to capture the fact that linking of tones to tone-bearing units in Margi is predictable in such cases. Verb stems in Margi have four possible underlying tonal representations:

- (68) a. Toneless: 1 syllable: [fa] → fâ 'to take (many)'
 2 syllables: [t̄ara] → t̄arà 'to go away'
- b. L-tone: 1 syllable: $\begin{bmatrix} \text{gha} \\ \text{L} \end{bmatrix}$ → ghà 'to reach'
 2 syllables: $\begin{bmatrix} \text{dza'u} \\ \text{L} \end{bmatrix}$ → dzà'ù 'to pound'
- c. H-tone: 1 syllable: $\begin{bmatrix} \text{ta} \\ \text{H} \end{bmatrix}$ → tá 'to cook'
 2 syllables: $\begin{bmatrix} \text{nguli} \\ \text{H} \end{bmatrix}$ → ngúlí 'to roar'
- d. LH tones: 1 syllable: $\begin{bmatrix} \text{fi} \\ \text{L H} \end{bmatrix}$ → fǐ 'to swell'
 2 syllables: $\begin{bmatrix} \text{zədu} \\ \text{L H} \end{bmatrix}$ → zə́dú 'to take off'

The crucial point is that melodies in Margi are independent of the segmental make-up of the verb stem (NB: Leben 1973, Goldsmith 1976).

It is not the case, for example, that there are more tonal possibilities for disyllabic verb stems than for monosyllabic verb stems. To allow tones to be pre-linked as in (65) or (67) would incorrectly predict Low - Rising sequences to be possible for disyllabic stems. So, since pre-linking makes the wrong predictions in Margi, we are forced into a cyclic account to properly derive the various patterns seen in this chapter.

7. Conclusion

By incorporating the notion of 'extratonicity' into the theory of tone, a formal similarity is established between the related phenomena of stress and tone. Accounts of 'lowering' and 'polarity' are accounted for within an extratonic account without requiring morphologically triggered rules. And by analysing lowering and polarity in terms of the phonological marking of extratonicity on certain morphemes, the peripheral nature of such phenomena is automatically accounted for.

Although the argumentation in this chapter has been drawn exclusively from Margi, we saw in chapter 4 that extratonicity plays a role in the Remote Dependent Affirmative tense of Tonga. In the next chapter, it will also be shown that extratonicity plays an important role in understanding the Imperative and Subjunctive tenses of Tiv.

FOOTNOTES: CHAPTER 5

1. There are no L-tone derivational suffixes in Margi, but there are certain pronominal suffixes that are L-tone, and certain inflectional suffixes that include a L-tone. That the pronominal elements in question are suffixes is clear from the fact that they occur inside certain plural and tense suffixes.
2. Evidence for cyclic tone association in Margi will be given in sections 2. and 6. below.
3. I assume that the plural marker in these cases is a word or particle and not a suffix, since it can pluralize the head of a noun phrase: for example, ndàr gá Íjù 'the word of God' vs. ndàr gá Íjí 'yàr kù 'these words of God'; íjìnyá Mádù 'Madu's grandparent' vs. íjìnyá Mádà 'yàr 'Madu's grandparents'.
4. Hoffmann describes gà and other similar prefixes as 'particles' creating verbal complexes (ga + verb, etc.). Whether he had some reason for distinguishing between 'prefixes' and 'particles' is not clear.
5. While the output of (29) and (36) is as desired, the input of both rules requires some modification to account for both 'subject of S' and 'subject of NP'. The generalization is that subject clitics are attached to the right of the head of their category, S or NP. Note also that both X^0 and \bar{X} representations have been proposed for clitics. See Rivas (1977) and Jaeggli (1980) for the

\bar{X} approach, and Borer (1981) for the X^0 approach. I have not got enough data to test for the syntactic implications of the dual X^0/\bar{X} analysis presented in this chapter.

6. I will restrict my examples to where the X of the X + CL constituent ends in a H-tone. Where X ends in a L, Floating H-deletion is inapplicable, and the lexical H of the clitic will always surface.

7. Williams (1971) commented that there were no L-tone suffixes in Margi -- such a gap being unexplained in his account. It would appear that he was correct in not explaining the gap since the gap itself does not appear to exist. It is, however, true that the marking of L-tones on affixes appears to be the exception rather than the rule.

8. Note that the tone of ɲi could not be involved in spreading because spreading does not take place over word-boundaries in Margi.

CHAPTER 6: TIV

Since Arnott (1964), verb tenses in Tiv have largely been analysed as involving a basic dichotomy between tonal and segmental features. Tonal formulas representing tense/aspect information combine with segmental lexical entries to derive tensed verbs. Various versions of this approach are to be found in Arnott (1964), McCawley (1970), Leben (1973) and Goldsmith (1976).

This chapter will depart from such 'tonal formula' accounts. Tensed verbs will be derived by the concatenation of verb stems with tense affixes, where both stems and affixes may consist of segments and tones. An understanding of the phonology of such [stem, affix] combinations is possible within the lexical framework. Tone association conventions apply cyclically, as do phonological rules assigned to the lexicon. Lexical and post-lexical constraints on rule application are shown to differ. The restricted distribution of contour tones in Tiv is also explained within an approach that distinguishes between lexical and post-lexical processes.

Crucial to the account given, is a formulation of the association conventions where spreading of tones is not automatic. Tones are linked to tone-bearing units in a strict one-to-one fashion unless some language-specific rule applies to modify such linkings. Consequently, many words will be left partially unspecified at the end of their lexical derivation, making it necessary for tonal default rules to apply.

1. Downstep

There are a number of reasons for analysing downstep in Tiv as being triggered by a floating L-tone. First, it was proposed in chapter 2 that the phonetic component that creates downdrift/downstep is extremely restricted in terms of what it can refer to. The location of phonetic downsteps must be predictable from the composition of the phonological string. Where there is no surface tone to trigger downstepping, I follow Clements and Ford (1979) in assuming that an unassociated tone is present in the tonal string to trigger downstep.

As a general rule in Tiv, H-tones undergo downdrifting after L-tones. Consider for example the pitch-level of gá 'not' in the following examples:

- (1) a. á vé gá [ˉ ˉ ˉ] 'he did not come (recently)'
 b. á dzà gá [ˉ ˉ -] 'he did not go'

In (1a), gá is on the same pitch-level as á, but in (1b), gá is lower than á because of the intervening L-toned verb dzà. Looking at the interval between a H and a following !H, we observe that it is the same as between the two H-tones in a H L H sequence, where the intervening L is linked. Compare, for example, (2a) and (2b) with the forms given in (1).

- (2) a. á vé [ˉ ˉ] 'he came (recently)'
 b. á !vá [ˉ -] 'he came'

By analysing 'downstep entities' as floating L-tones, we correctly predict that the extent of pitch lowering will be the same whether the trigger is a downstep entity or a linked L-tone.

Another argument comes from Arnott (1964, 1968) where it is shown that downsteps in Tiv alternate with L-tones under certain circumstances. Consider the following examples:

- | | | | |
|-----|----|--|---------------------------|
| (3) | a. | ûnyînyâ mbâ
horses copula | 'there are horses' |
| | b. | mbâ [!] vâ
cop. coming | 'they are coming' |
| (4) | a. | káséví mbâ
women copula | 'there are women' |
| | b. | káséví mbâ [!] gá
women cop. NEG | 'there are not any women' |
| (5) | a. | íwá ngî
dogs copula | 'there are dogs' |
| | b. | íwá ngî [!] yévèsè
dogs cop. fleeing | 'the dogs are fleeing' |

The copulas in (3-5) have a falling tone on a short vowel pre-pausally, but occur as H! in non-pre-pausal position. Assuming that a falling tone is created by a H L sequence mapped onto a single vowel, this means that a pre-pausal L is alternating with a non-pre-pausal !. Moreover, this tonal behaviour is not restricted to any particular class of lexical items; Arnott gives examples with copulas, verbs (Habitual 2) and nouns. If the downstep entity is not analysed as a floating tone, then there is no obvious explanation

for alternations such as those seen above.¹

In order to make two final arguments for representing downstep as a floating L in Tiv, I will side-track to motivate a general rule of H-spread.

1.1 H-spread

Consider pairs of nouns such as those given in (6):

(6)	<u>stem</u>	<u>sing.</u>	<u>plural</u>	
a.	daka H	dákà	ùdákà	'type of gun'
b.	dari L H	dàrí	ùdàrí	'half-penny'

We observe that in the singular, such nouns do not have a noun-class prefix, while in the plural, there is a L-tone ù- prefix. These examples are included merely to illustrate the rather bland observation that the addition of a L-tone prefix to a noun has no effect on the tonal pattern of a stem.

In marked contrast, consider below what happens when it is a H-tone prefix that is added to a noun stem:²

(7)	<u>stem</u>	<u>sing.</u>	<u>plural</u>	
a.	bagu L	bàgù	íbá!gú	'red monkey'
b.	kagha L	ìkàgh	áká!gh	'bundle'
c.	keghe L H	ìkègh	íké!gh	'chicken'

ákaàndé 'type of shellfish (pl)' (7e), where each noun consists of a stem, a class suffix, and a class prefix.

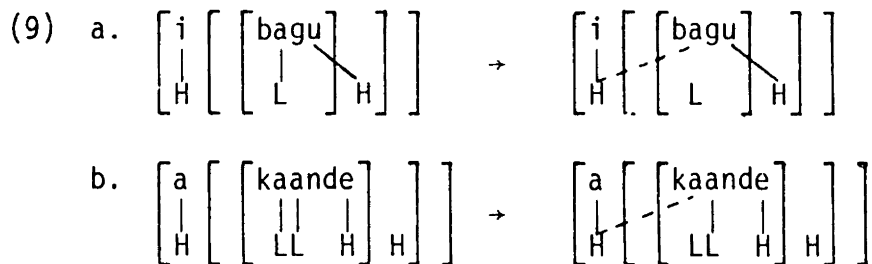

It is important to note that H-spread (8) is a rule that applies not only to nouns, but to verbs as well. For example, the Present Continuous tense consists of a H-tone prefix marking the 'present' tense and a segmental suffix -n marking the 'continuous' aspect. In (10), I give a partial (and simplified) derivation of a form such as mbá[!]véndà̀n 'they are refusing', illustrating the application of H-spread in a Present Continuous form.

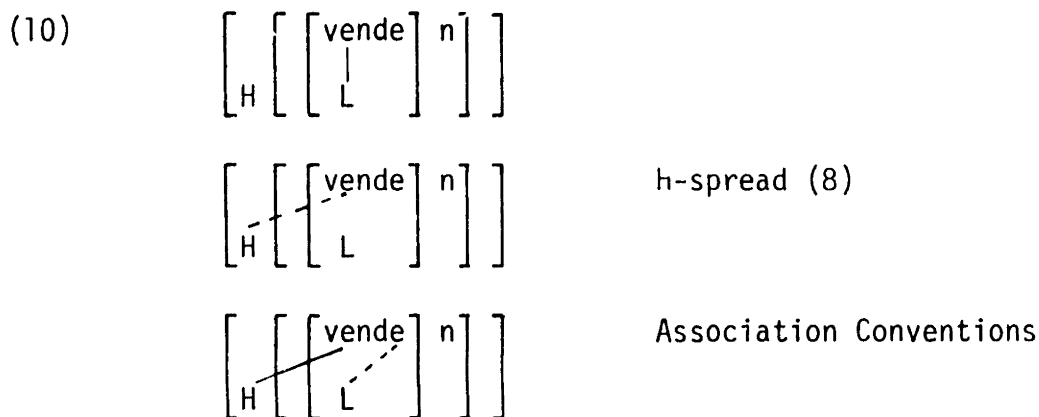

As a final example, I will give a case of H-spread triggered by the addition of a H-tone subject prefix to a L-tone verb stem. The particular example in (11) involves the Recent Past tense which is

marked be a H-tone suffix.

- (11)
$$\left[\begin{array}{c} \text{ve} \\ | \\ \text{H} \end{array} \left[\left[\begin{array}{c} \text{vende} \\ | \\ \text{L} \end{array} \right] \text{H} \right] \right]$$
- $$\left[\begin{array}{c} \text{ve} \\ | \\ \text{H} \end{array} \left[\begin{array}{c} \text{vende} \\ | \\ \text{L} \end{array} \right] \text{H} \right]$$
 H-spread (8)
- $$\text{vé vé}^{\text{!}}\text{ndé} \quad \text{'they refused (recently)'}^{\text{'}}$$

From all of the examples given in this section, it is clear that H-spread is a general and productive rule of Tiv, applying in both nouns and verbs.

1.2 Downstep (continued)

All of the alternations discussed in section 1.1 are explained by assuming that when a L is caused to float by the rule of H-spread, the delinked L automatically triggers downstepping of a following H. If the downstep entity is not viewed as a floating L, then these alternations are left unexplained.

As a final point, there is evidence for the existence of a floating L-tone even in configurations where there is no downstep. Consider a tense like the General Past. In an example like á [!]vá 'he came' (2b), we see that this tense is marked by an initial downstep. If this downstep must be marked by a floating L-tone, then we are forced to assume a L-tone prefix for the General Past. Hence because of the downstepping before H-tone verbs, we are forced to represent L-tone verbs in the General Past as in (12).

$$(12) \quad \left[\begin{array}{c} \sigma \ (\sigma) \ (\sigma) \\ | \\ \underline{L} \end{array} \right] \left[\begin{array}{c} \sigma \ (\sigma) \ (\sigma) \\ | \\ \underline{L} \end{array} \right]$$

Although the floating \underline{L} is not pronounced in such a configuration, there is evidence for its existence. Consider a General Past form such as vé vèndè 'they refused'. Under the hypothesis that the General Past is marked by a L-tone prefix, we will have the configuration in (13a); if there were no L-tone prefix, we would have (13b).

$$(13) \quad \text{a.} \quad \left[\begin{array}{c} \text{ve} \\ | \\ \underline{H} \end{array} \left[\begin{array}{c} \underline{L} \left[\begin{array}{c} \text{vende} \\ | \\ \underline{L} \end{array} \right] \end{array} \right] \right] \quad \text{b.} \quad \left[\begin{array}{c} \text{ve} \\ | \\ \underline{H} \end{array} \left[\begin{array}{c} \text{vende} \\ | \\ \underline{L} \end{array} \right] \right]$$

In (13a), H-spread is not applicable; in (13b) H-spread is applicable:

$$\left[\begin{array}{c} \text{ve} \\ | \\ \underline{H} \end{array} \left[\begin{array}{c} \text{vende} \\ | \\ \underline{L} \end{array} \right] \right]$$

From the representation in (13a), we therefore correctly predict the surface form vé vèndè, while from (13b), we incorrectly predict *vé véndè. We see therefore that the \underline{L} - prefix -- postulated in order to account for the downsteps that occur with H-stem verbs -- provides an automatic explanation for why H-spread does not apply to cases like (13a). In such cases, the structural description of H-spread is simply not met since the rule only spreads a \underline{H} onto an immediately following linked \underline{L} .

To conclude, I have shown that by analysing downstep in Tiv as

being triggered by a floating L-tone, an account is provided for downsteps alternating with contour tones (3-5), for downsteps being created by spreading rules (7-11), and for 'downsteps' preventing spreading rules (13).

2. The Cycle

We have already seen in section 1 that in a language like Tiv, tone can constitute part or all of any given lexical entry. Let us consider the effect, therefore, of the following two assumptions:

- (14) i. The association conventions apply automatically at all stages of a derivation (NB: Goldsmith 1976), subject to the Relinking Condition (see chapter 3, figure 39).
 ii. The output of every word-formation process in Tiv is scanned by the phonological component.

The effect of the the two statements of (14) is that tone association in Tiv will be cyclic.

Consider a configuration like the following:

$$(15) \quad \left[\begin{array}{c} \left[\begin{array}{ccc} V & V & V \end{array} \right] \\ L \left[\begin{array}{c} H \end{array} \right] \end{array} \right]$$

Assuming that the association conventions assign tones to tone-bearing units one-to-one from left to right, then a theory with cyclic tone association would predict the tonal pattern given in (16a), while a non-cyclic approach would give the pattern in (16b).

$$(16) \quad \text{a.} \quad \left[\begin{array}{c} \left[\begin{array}{c} V \quad V \quad V \\ \vdots \\ H \end{array} \right] \\ L \end{array} \right] \quad \text{b.} \quad \left[\begin{array}{c} \left[\begin{array}{c} V \quad V \quad V \\ \vdots \\ H \end{array} \right] \\ L \end{array} \right]$$

In the absence of any special rule, the left-over vowels in (16a) and (16b) would be assigned default tones.

Consider now the following forms from the General Past tense:

(17) General Past

	<u>H-stem</u>		<u>L-stem</u>	
1 syllable:	!vá came	!H	dzà went	L
2 syllable:	!úngwà heard	!HL	vèndè refused	LL
3 syllable:	!yévesè fled	!HLL	ngòhòrò ³ accepted	LLL

An example like !yévesè -- which combines a H-tone trisyllabic stem with a L-tone prefix -- provides us with precisely the configuration seen in (15):

$$(18) \quad \left[\begin{array}{c} \left[\text{yevese} \right] \\ L \quad \left[\begin{array}{c} H \end{array} \right] \end{array} \right]$$

Cyclic tone association will derive the correct result in this case.

On the first cycle, the tone of the stem will associate:

$$(19) \quad \text{a.} \quad \left[\begin{array}{c} \text{yevese} \\ \vdots \\ H \end{array} \right]$$

On the second cycle, the L-tone of the prefix has nowhere to link -- and therefore remains floating.

$$b. \quad \left[\begin{array}{c} L \\ \left[\begin{array}{c} \text{yevese} \\ | \\ H \end{array} \right] \end{array} \right]$$

We see that the assumptions in (14) give us exactly the right results in a tense like the General Past. I have assumed the minimal amount of tonal information possible for verb stems -- namely that they are monosyllabic, disyllabic or trisyllabic and bear either a H or a L:

(20) a. H-stem verbs

b. L-stem verbs

$$\left[\begin{array}{c} V (V) (V) \\ H \end{array} \right]$$

$$\left[\begin{array}{c} V (V) (V) \\ L \end{array} \right]$$

I have also assumed what is presumably the minimal amount of information required for the General Past tense, namely that it consists of a L-tone prefix: [L - . And following the argument of section 1., I have assumed that a floating L-tone triggers downstep.

It appears, therefore, that within the cyclic approach derived by (14i) and (14ii), one can account for a tense like the General Past without any unmotivated stipulations or rules.

3. Automatic spreading

In section 2., we saw that tone association must be cyclic in order to account for facts involving downstep. But if tone

association is cyclic, then consider the derivation of a Recent Past verb such as seen in (11). In (21a) I give the form that would result if spreading of a linked tone onto toneless vowels were considered to be automatic; in (21b) I give the form that would result without automatic spreading.

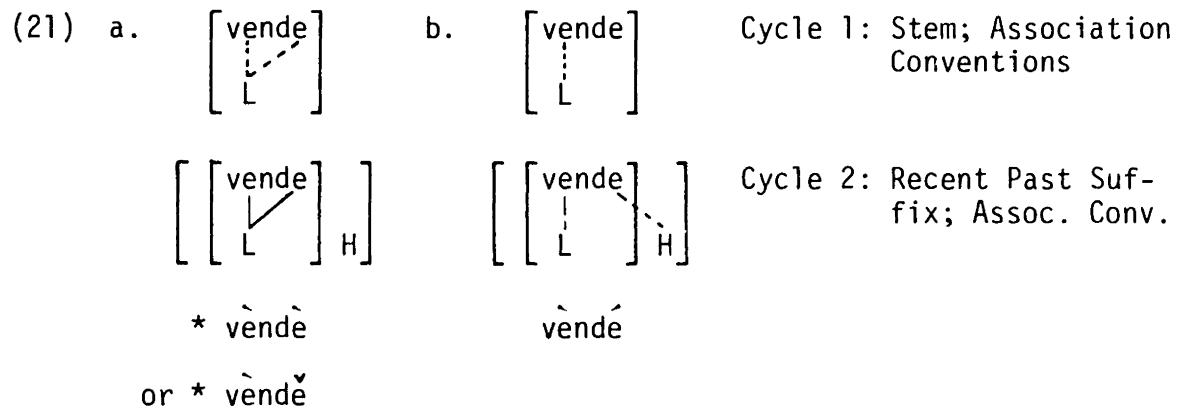

We see that the inclusion of the cycle in the tonal phonology of Tiv requires that we abandon the convention of spreading tones automatically.⁴ Automatic spreading would require that a case such as (11) be derived non-cyclically; and a non-cyclic approach would make it impossible to maintain the unified account of downstep presented above, without adding ad hoc stipulations to account for a tense such as the General Past.

Since the revised set of association conventions is crucial for an understanding of tone in Tiv, I will review briefly here what is at issue.⁵ The principles for relating autosegmental tiers are of two types. The 'Association Conventions' constitute an algorithm for mapping tones onto tone-bearing units; the 'Well-formedness Condition' constitutes a constraint on what is a well-formed

representation. Consider (22) and (23) below:

(22) Association Conventions:

- a. Map a sequence of tones onto a sequence of tone-bearing units, i. from left to right
 - ii. in a one-to-one relation.
- (b. Left-over tones are assigned to the last tone-bearing unit.)
- (c. Last tone spreads to remaining untoned tone-bearing units on right.)
- (d. Association conventions only apply to floating tones.)

(23) Well-formedness Condition:

- a. Association lines do not cross.
- (b. All tone-bearing units are associated with at least one tone.)
- (c. All tones are associated with at least one tone-bearing unit.)

Clauses (22a) and (23a) are relatively uncontroversial -- and they are the only clauses that are considered in this thesis to be universal. But consider a representation like (24), shown after clause (a) of the Association Conventions in (22) has applied.

(24)
$$\left[\begin{array}{ccccc} V & V & V & & \\ | & | & | & & \\ H & L & H & L & H \end{array} \right]$$

Although Goldsmith (1976) proposed that the free tones in such a

case should be automatically linked, Williams (1971), Clements and Ford (1979) and Halle and Vergnaud (1982) have suggested that the linking (if any) in such a case should be by language-specific rule. The latter position is supported by numerous examples in this thesis. In Dschang (chapter 2, section 5.1), we saw that the free tone in sequences like those in (25) did not link.

- (25) a. kan 'squirrel'
 |
 L H
- b. mɔ 'child'
 |
 L H

In Yala (chapter 3, section 2.), it was crucial that the initial floating L in a case like (26) did not link automatically.

- (26) [gbɛhɛ]
 |
 L L

For Yoruba (chapter 3, section 3.2), downstepped M-tones were accounted for by a representation where a free L-tone did not link. And in Tiv, if the L-tone in a case like (19b) were to link automatically, then a special (and otherwise unnecessary) rule would be required to delink the L in question.⁶ Lastly, Margi shows that language-specific constraints on the linking of tones to tone-bearing units would not be sufficient to block multiple linkings in the appropriate instances. That is, we cannot assume that (22b) is a universal convention, but that it is blocked in certain languages by constraints such as that in (27).



In Margi, multiple linkings such as prohibited by (27) are possible. Rising tones are attested on verbs such as the following:

- (28) a. bdiǎ 'to forge'
 b. hǎ 'to grow up'

Nevertheless, the second tone of such contours must not be linked until the word-level -- that is, it must not link automatically. If stems such as those in (28) are followed by a toneless suffix, then the derivation is as follows:

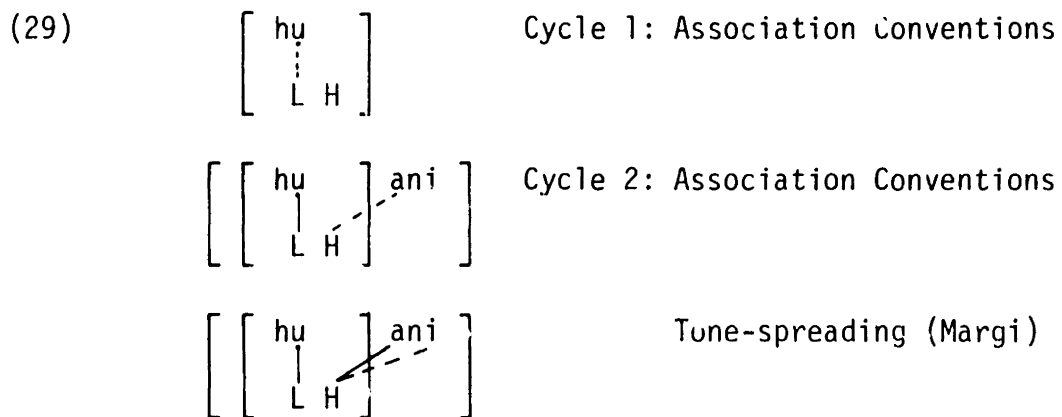

After a rule of vowel deletion, the surface form hání 'to blow up with pride' is attested. The crucial point is the following: If the H of the stem had automatically linked on the first cycle, then a special rule would be required to de-link it after adding the derivational suffix -ani.

If clause (b) of the Association Conventions in (22) is not a language-universal, then clause (c) of the Well-formedness Condition cannot be correct. That is, if conventions do not apply to change the representations in examples like (24-26), then surely we do not want our theory to rule them out as ill-formed. Hence rejection of the (b) clause in (22) entails rejection of the (c) clause in (23).

Concerning the spreading of a tone onto toneless tone-bearing units, this thesis argues that such spreading is by rule only -- and not by convention. This point has been argued explicitly in earlier chapters , and is the main point of this section. Clause (c) of the Association Conventions in (22) is not held to be a universal of human language. Note that the rejection of the 'spreading' clause of the Association Conventions affects the formulation of the Well-formedness Condition in (23). While it may be true at the phonetic level that all tone-bearing units must be associated with a tone, this cannot be true in the phonological derivation, if the approach taken by this thesis is correct. Hence clause (23b) cannot be a condition on phonological derivations.

Lastly, concerning clause (d) of (22), I have bracketed it not because it is incorrect, but because it can be derived from (22a). If the associations performed by convention are strictly one-to-one, then the conventions cannot perform the type of multiple linking that would result from further association of a linked tone.

As stated in chapter 1, therefore, I assume that the universal Association Conventions consist of clause (a) in (22); and the

universal Well-formedness Condition on phonological derivations consists of clause (a) of (23).

3.1 Past tense forms

We saw in section 2. that the General Past is marked by a [L - prefix. This prefix triggers downstep with the H-stem verbs and prevents H-spread (8) from applying between subject prefixes and L-stem verbs. Concerning the tones that surface on the verb stem itself, an inspection of the forms in (17) shows that the lexical tone (note figure 20) appears on the first vowel of the stem, exactly as it should given left-to-right association. Any additional stem vowels surface as L. In the preceding section, it was argued that if tone association is cyclic (as it must be in Tiv), then spreading cannot be automatic. This allows a treatment of the General Past where the sole tense marker is a [L - prefix; the second and/or third vowel of a disyllabic or trisyllabic verb stem is assigned a L-tone by the theory of default rules developed in chapter 3.

- (30) $\left[\begin{array}{c} \text{yevese} \\ \vdots \\ \text{H} \end{array} \right]$ Cycle 1: Stem; Association Conventions
- $\left[\text{L} \left[\begin{array}{c} \text{yevese} \\ | \\ \text{H} \end{array} \right] \right]$ Cycle 2: General Past Prefix
- $\left[\begin{array}{c} \text{yevese} \\ | \quad | \quad | \\ \text{L} \quad \text{H} \quad \text{L} \quad \text{L} \end{array} \right]$ Default L-insertion
- !yévèsè

Hence a theory that assigns L as a default value, and that does not have automatic spreading, can account for the General Past in a maximally simple way, that is, as marked by a [L - prefix.

Consider now the forms of the Recent Past: ⁷

(31) Recent Past

	<u>H-stem</u>		<u>L-stem</u>	
1 syllable:	vé came (rec.)	H	dzé went (rec.)	H
2 syllable:	óngó heard (rec.)	HH	v̀ndé refused (rec.)	LH
3 syllable:	yévesè fled (rec.)	HHL	ngòhòrò ⁸ accepted (rec.)	LHL

Segmentally, the Recent Past tense involves a process of ablaut. However, as the ablaut rule does not affect tonal representations, it will not be discussed here. ⁹ Concerning its tonal forms, it was suggested above (see figure 11) that this tense is marked by a -H] suffix. Assuming that spreading is not automatic, this -H] will link to the second vowel of the stem, when there is such a second vowel, producing configurations such as the following:

(32) a.	[yevese] H	b.	[ngohoro] L	Cycle 1: Stem; Assoc. Conv.
	[[yevese] H - - - -] H]		[[ngohoro] L - - - -] H]	Cycle 2: Rec. Past; Assoc. Conv.

The left-over vowel in such cases will be assigned L by default,

correctly resulting in the surface forms yévésè and ngòhòr after late rules of vowel deletion and tone attachment.

There is one residual problem concerning the derivation of a form such as dzé 'went (recently)'. The expected derivation of such a form would result in a configuration such as in (33).

$$(33) \quad \left[\left[\begin{array}{c} \text{dze} \\ | \\ \underline{L} \end{array} \right] \text{H} \right]$$

Clearly, some rule is required to change the lexical L of the verb stem into a H in such cases. Note, moreover, that the stem L cannot simply be delinked by the -H] suffix since that would incorrectly predict a downstep in a form such as vé dzé 'they went', where the verb stem is preceded by a H-tone subject prefix. To account for forms like dzé, I propose a rule that raises a L to H when it is followed by a floating H.

$$(34) \text{ Raising: } \quad \underline{L} \quad \rightarrow \quad \text{H} \quad / \quad \text{---} \quad \textcircled{\text{H}}$$

This rule applies generally and its effect will be seen in a number of tenses, such as the Imperative, the Habitual and the Subjunctive. The rule will also be shown to play a role in accounting for the surface distribution of contour tones in Tiv.

In summary, we see that a theory of tone that does not include automatic spreading can account for the Recent Past forms in Tiv by simply positing a -H] suffix. Hence both the General Past and the Recent Past are given tonal representations that make no reference

to the segmental composition of verb stems.

In contrast to the straightforward account for these tenses given above, a theory postulating automatic spreading requires a number of complications. First, such a theory cannot assume cyclic association and consequently must find an alternative account for the initial downstep in tenses such as the General Past. Secondly, it cannot be maintained in the General Past, for example, that there is no tone following the lexical tone of the stem, since were such to be the case, the lexical H-tone of the H-stem class would automatically (and incorrectly) spread to all vowels of the stem. Hence one must posit a L-tone following the lexical tone in this tense.¹⁰ This in itself is problematic since such a putative L-tone does not appear when the verb stem is monosyllabic, as in vé [!]vá 'they came'. Leben (1973) and Goldsmith (1976) suggest that this problem can be solved by a rule that Leben calls Tone Simplification (Tiv) and that I reproduce as (35).

- (35) Delete any L that occurs in sequence with H on a [+syllabic] segment.

We have already seen in (3-5) above, however, that there are H L sequences on short vowels in Tiv, and (35) cannot, therefore, be a general rule. Hence Leben's Tone Simplification (Tiv) (and Goldsmith's 'Fall-Simplification') cannot be maintained except perhaps as a minor rule restricted to a tense such as the General Past. Hence in a theory that postulates automatic spreading, one is forced to

assume an ad hoc rule for the General Past or to assume different forms for the General Past morpheme depending on the number of syllables in a verbal stem.

Looking at the Recent Past, the automatic spreading solution encounters a similar problem since the final \underline{L} of the trisyllabic forms requires that a \underline{L} be present in the representation of the tense for such forms in order to prevent spreading of the $-H$] suffix. And yet this putative \underline{L} does not surface with monosyllabic and disyllabic stems. We are again forced to assume that there is more than one Recent Past morpheme, and that the correct choice of tense melodies depends on the number of syllables in a verb stem.

(36) Tense representations in a theory with automatic spreading:

General Past affixes:	Representative stems:	Recent Past affixes:
[L-	{ [va] _H , [dza] _L }	-H]
[L-, -L]	{ [ungwa] _H , [vende] _L }	
	{ [yevese] _H , [ngohoro] _L }	-H L]

In conclusion, we see that a theory that assumes automatic spreading, and lexical representations for verbs as in (20), is forced to posit non-uniform underlying representations for tense morphemes such as the General Past and Recent Past. In addition to a [L- prefix, the automatic spreading approach is forced to posit a -L] suffix for

disyllabic and trisyllabic verb stems in the General Past. And for the Recent Past, the automatic spreading approach must assume a -H] suffix for monosyllabic and disyllabic stems, but a -H L] suffix for trisyllabic stems. In fact, it is accidental in such an approach that the various melodies constituting a particular tense are as similar as they are, and that the 'extra' tones are required only for 'extra' syllables, after the assignment of the basic part of the tense melody. I argue, therefore that inclusion of automatic spreading in tonal theory results in a considerable loss of generalization with tenses such as the General Past and the Recent Past.

3.2 H-spread

Let us return to the General Past form of a H-stem trisyllabic verb such as yevese. As was argued in section 3.1, a theory with automatic spreading would have to assign a representation to ˈyévèsè as in (37a), while a theory without automatic spreading could assign a representation as in (37b). I ignore the question of how a theory with automatic spreading would represent the initial downstep in such a case.

$$(37) \quad \text{a.} \quad \left[\begin{array}{c} \text{yevese} \\ | \quad | \\ \text{!} \quad \text{H} \quad \text{L} \end{array} \right] \quad \text{b.} \quad \left[\begin{array}{c} \left[\begin{array}{c} \text{yevese} \\ | \\ \text{H} \end{array} \right] \\ \text{L} \end{array} \right]$$

Although (37a) meets the structural description of H-spread (which I repeat below as (38)), (37b) does not.

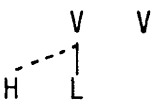
(38) H-spread: 

Hence a theory with automatic spreading incorrectly predicts that the rule of H-spread should apply to such cases, giving an incorrect surface form such as *!yévésè. A theory without automatic spreading can correctly block H-spread in such cases by simply ordering the assignment of default values after H-spread.

3.3 Habitual 3

As a final argument against automatic spreading, I wish to consider a case which, on the face of it, seems to argue for automatic spreading. I will argue, however, that the spreading involved is in fact yet another case of H-spread, and that attributing it to universal conventions entails a loss of generalization. Consider the forms below:

(39) Habitual 3

	<u>H-stem</u>		<u>L-stem</u>	
1 syllable:	!váán come	!HHH	!dzáán go	!HHH
2 syllable:	!úngwán hear	!HHH	vèndán refuse	LHH
3 syllable:	!yévésén flee	!HHHH	ngòhóron accept	LHHH

It would seem, at least superficially, that this tense involves a H-tone suffix that has spread to all tone-bearing units of the verb.

But consider the following forms, which correspond to the Habitual 1 tense:

(40) Habitual 1

	<u>H-stem</u>		<u>L-stem</u>	
1 syllable:	!vá come	!H	!dzá go	!H
2 syllable:	!úngwá hear	!HH	vëndá refuse	LH
3 syllable:	yévése ¹¹ flee	HHL	ngòhòrò ¹² accept	LHL

Apart from the initial downstep, tonal forms in the Habitual 1 are identical to forms in the Recent Past. I assume therefore that there is a H-tone suffix in the Habitual 1 tense just as there is in the Recent Past. It turns out to be the case, moreover, that this habitual -H] occurs in all forms of the habitual. (See Appendix)

There are two important differences between the Habitual 1 and the Habitual 3. In the Habitual 1, we observe a H-tone suffix and no spreading; in the Habitual 3, we observe a H-tone suffix, a segmental -n] suffix, and we get spreading. Hence the presence of the -n] suffix correlates with spreading. Why this should be the case becomes clear when we examine yet another habitual tense form, such as the Past Habitual:

(41) Past Habitual

	<u>H-stem</u>		<u>L-stem</u>	
1 syllable:	!vaân !HHL used to come		!dzaân !HHL used to go	
2 syllable:	!úngwân !HHL used to hear		vèndân LHL used to refuse	
3 syllable:	!yévéсэн !HHHL used to flee		ngòhórôn LHHL used to accept	

The Past Habitual is marked by the L-tone prefix of the General Past and two habitual suffixes: the -H] suffix observed in the Habitual 1, and a segmental -n] suffix that bears a L-tone. The surface form of a L-stem such as ngohoro in the Past Habitual is therefore derived with no trouble:

(42)

[ngohoro]	Cycle 1: Stem; Association Conventions
[[ngohoro]]	Cycle 2: Habitual suffix; Assoc. Conventions
[[[ngohoro]] n]	Cycle 3: Habitual suffix; Assoc. Conventions
[[[ngohoro]] n]	H-spread (38); Assoc. Conventions
[L [[[ngohoro]] n]]	Cycle 4: General Past prefix

which appears on the surface to be produced by context-free spreading, there is in fact a loss of generalization unless we attribute the spreading to the Tiv-particular rule of H-spread.

3.4 The Association Conventions (revised)

In the preceding section, four arguments have been presented to show that tone spreading cannot be automatic in Tiv. First, it was shown that automatic spreading is impossible if tone association is cyclic. Second, it was shown that automatic spreading results in a loss of generalization in the formulation of tenses such as the General Past and the Recent Past. Third, because of the melody required for a tense such as the General Past in a theory with automatic spreading, such a tense would have to be marked as an exception to an otherwise general rule of H-spread. Fourth, it was shown that an apparent case of context-free spreading in the Habitual 3 tense is actually a case of H-spread.

Since spreading is not automatic in Tiv, it cannot be a universal property of human language.

I conclude therefore that the universal aspects of the Association Conventions and the Well-formedness Condition are as follows:

- (44) Association Conventions: Map a sequence of tones onto a sequence of tone-bearing units, a) from left to right
 b) in a one-to-one relation.

(45) Well-formedness Condition: Association lines cannot cross.

3.5 An alternative

Before concluding this section, I will discuss briefly an alternative analysis suggested by John Goldsmith which would preserve automatic spreading as a language universal. His suggestion depends crucially on the interpretation of the Elsewhere Condition discussed briefly in chapter 4, section 8.5 in connection with Tonga.¹³ I repeat the proposal here: '[T]he more GENERAL rule can be precluded from applying not only by the ACTUAL application of the more specific rule, but the PRESENCE of the more specific rule -- that is, its potential application later in the derivation.' (Goldsmith 1982 p.24)

Given this version of the Elsewhere Condition, one might propose the following: Assume that automatic spreading is a part of universal grammar and therefore constitutes the 'GENERAL' rule for purposes of the Elsewhere Condition. Assume further that as a part of its grammar, Tiv includes a language-specific rule of L-insertion. If we consider L-insertion to be the more specific rule, then the application of automatic spreading will be precluded by the existence of L-insertion.

Note especially that automatic spreading could not be blocked merely by the application of L-insertion. Examples like the one seen in (37) above show that L-insertion must apply after H-spread:

(46)	$\begin{array}{c} \text{yevese} \\ \\ \text{L H} \end{array}$	General Past
	N/A	H-spread (38)
	$\begin{array}{c} \text{yevese} \\ \quad \quad \\ \text{L H L L} \end{array}$	L-insertion
	$! \text{yévèsè}$	

If L-insertion is a language-specific rule of Tiv, then it must be extrinsically ordered to apply after H-spread. This means that at early stages of the derivation, automatic spreading is blocked not because L-insertion has applied, but because ultimately it will apply.

The above position is problematic for a number of reasons. First, it depends on a rather powerful interpretation of the Elsewhere Condition that is not clearly required independently. For example, the evidence from Tonga that Goldsmith proposes as motivation for the revised Elsewhere Condition receives alternative analyses in Halle and Vergnaud (1982) and in this thesis -- and neither of these alternatives requires such a principle.

In any event, even if the revised form of the Elsewhere Condition is correct, it cannot account for the lack of spreading in Tiv. According to both the revised and unrevised versions of the Elsewhere Condition, it is the 'specific' rule that blocks the application of the 'general' rule. Crucially, one must distinguish between the 'general' rule and the 'specific' rule on formal grounds --

not by a priori assignment of one of the rules to universal grammar. The special rule is defined as that whose structural description properly includes the structural description of the general rule. But when we consider the structural description of the two rules of Default L-insertion and Spreading, we see that it is the structural description of Spreading that properly includes that of Default L-insertion; on formal grounds, it is L-insertion and not Spreading that is the general rule:

(47) a. Default L-insertion:

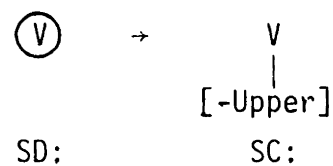

b. Spreading (mirror image):

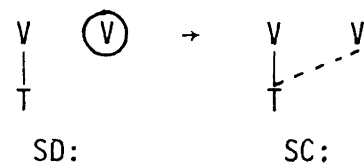

Were Spreading to be universal -- and subject to the Elsewhere Condition -- then it would preclude application of L-insertion. Consequently, even for a theory including Goldsmith's version of the Elsewhere Condition, spreading cannot be universal.

4. Lexical constraints

In this section, I wish to propose two constraints that hold of rules applying in the lexicon, but not of rules applying post-lexically. In order to motivate these constraints, I must discuss

the distribution of contour tones and motivate the rule of vowel deletion that has been referred to in a number of footnotes.

4.1 Contour tones

To the best of my knowledge, the following are correct generalizations about falling and rising tones in Tiv.

- (48) a. Contour tones occur only in word-final position.
 b. Falling tones are possible on surface syllables of the forms (C)V and (C)VC.
 c. Rising tones are possible only on surface syllables of the form (C)VC.

We saw a number of examples of falling tones on CV syllables in (3-5):

- (49) a. ùnyìnyà mbâ 'there are horses' (=3a)
 b. kásé'í mbâ 'there are women' (=4a)
 c. íwá ngî 'there are dogs' (=5a)

Examples of falling tones on CVC syllables can be seen with words like the following:

- (50) a. ngòhôr 'accepted (recently)'
 b. swâm 'wild boar'
 c. kêr 'seek!'

Finally, some examples of rising tones are given in (51).

- (51) a. bǎr 'pond'
 b. ànyàm ngǔn 'this leopard'
 c. ìnyǒn 'bird'

There are two basic issues to be kept in mind regarding contour-toned syllables. First, we must explain why rising tones never occur on (C)V syllables. Second, we must explain why a (C)VC syllable counts as two tone-bearing units for purposes of tense assignment. For example, ngòhòr (50a) gets the LHL tonal pattern of a trisyllabic Recent Past form, not the LH pattern we would expect for a disyllabic form (see 31).

One obvious approach to the latter problem would be to define tone-bearing units in Tiv as any segment in a syllable-rime. Hence rising tones would be derived by associating one tone to the nucleus and one tone to the coda. Unfortunately, such a solution creates as many problems as it solves. We saw in (49) that a falling contour is possible on a CV syllable. In other words, a HL sequence can be mapped onto a single tone-bearing unit. It would follow that if a CVC syllable contains two tone-bearing units, we should be able to get the types of tone patterns illustrated in (52).

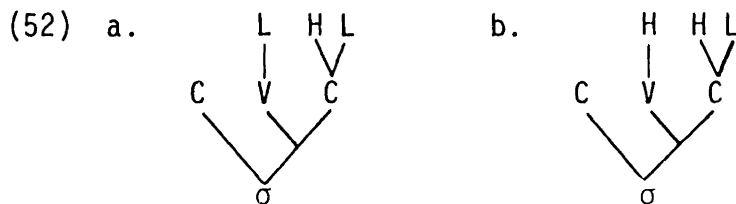

While this approach gives an explanation for why a CVC syllable

counts as two tone-bearing units, it does so at the expense of increasing the number of possible, but unattested, surface contours.

An alternative solution to the problem is possible along the following lines:

- (53) a. In the lexicon, there are no (C)VC syllables.
 b. Surface (C)VC syllables are derived from lexical (C)VCV sequences.
 c. All contour tones are derived by a rule of T-attachment.
 d. T-attachment is ordered after a rule deleting V_2 in appropriate ... $V_1 C V_2$] sequences.

The rule of T-attachment creates contour tones by linking a final floating tone to the last vowel of a word in pre-pausal position.

(54) T-attachment: $\left[\begin{array}{c} V \\ \vdots \\ \textcircled{T} \end{array} (C) \right] //$

In a case like ùnyìnyà mbâ (49a), T-attachment will apply as follows:

(55) $\left[\begin{array}{c} \text{unyinya} \\ | \quad | \quad | \\ L \quad L \quad L \end{array} \right] \left[\begin{array}{c} \text{mba} \\ | \\ H \quad L \end{array} \right]$
 $\left[\begin{array}{c} \text{unyinya} \\ | \quad | \quad | \\ L \quad L \quad L \end{array} \right] \left[\begin{array}{c} \text{mba} \\ | \quad \diagdown \\ H \quad L \end{array} \right] \quad \text{T-attachment (54)}$

Consider now the following cases, that illustrate the segmental rule of ablaut that occurs in certain tenses such as the Recent Past: (from Arnott 1964, p.24)

(56)	<u>Stem form</u>	<u>Ablaut form</u>	<u>Gloss</u>
	venda	vende	'refuse'
	hide	hidi	'return'
	tɔŋgo	tenge	'blow (eg. a flute)'
	dzɔhɔ	dzehe	'wrangle'
	ungwa	ongo	'hear'
	unde	undu	'mount'

Ablaut forms are predictable from the stem forms while the converse is not true. The rule of ablaut will not be discussed or formulated here¹⁴, as it is only its effect on stems such as those below that is relevant here.

(57)	<u>Stem form</u>	<u>Ablaut form</u>	<u>Gloss</u>
	gema	gem	'change'
	yira	yer	'summon'
	pine	pin	'ask'
	hura	hor	'weed'
	tsume	tsum	'make a mistake'

We observe that the second vowel in the ablaut forms given in (57) has been lost. Ablaut in (57) has triggered a vowel deletion rule while ablaut in (56) has not triggered vowel deletion. The reason for this difference between (56) and (57) lies in the nature of the final consonant involved. Vowel deletion is only possible when the C of the VCV sequence is one of the following: m, n, l, r, v, gh.

And yet while this is a necessary condition for vowel deletion, it is not a sufficient condition since we do not get vowel deletion in the stem forms of (57). We must put a second condition on vowel deletion: V_1 and V_2 of the $V_1 C V_2$ sequence may differ in terms of tenseness but must agree for all other features determining vowel quality. This condition on vowel sequences is met in all the ablaut forms of (56), but vowel deletion does not take place because the intervening consonant is not [+sonorant].¹⁵ On the other hand, ablaut feeds vowel deletion in (57) since it creates $V_i \begin{matrix} C \\ [+son] \end{matrix} V_i$ sequences.

I formulate the rule of vowel deletion as follows:

$$(58) \text{ V-deletion: } \left[\begin{array}{c} [+son] \\ | \\ V \quad C \quad V \\ \diagdown \quad \diagup \\ [\alpha F] \end{array} \right] \rightarrow \left[\begin{array}{c} [+son] \\ | \\ V \quad C \\ | \\ [\alpha F] \end{array} \right]$$

The rule of V-deletion is illustrated in the derivation of pin 'ask'. In the appropriate tense, the stem pine will undergo ablaut, (for the purposes of this illustration, tone is being ignored) and V-deletion:

(59)	[pine]	
	[pini]	Ablaut (CF: hide ~ hidi 'return')
	[pin]	V-deletion (58)

In light of the above, consider the following characteristics of CVC syllables in general:

- (60) a. (C)VC syllables occur word-finally.
 b. The C of the coda is always a [+sonorant].
 c. A word of n syllables behaves tonally like a word of n+1 syllables, when the final syllable is (C)VC.

All of these observations are easily explained if we assume that lexically, there are no (C)VC syllables. That is, the lexical inventory of syllables is only V and CV. Words ending in closed syllables must therefore be derived by positing an underlying final vowel that is deleted by V-deletion (58).

I assume, therefore, that verbs have underlying forms as in column A of (61) even when they appear in non-ablaut tenses (such as the General Past) as in column B; note that although V-deletion has deleted the final stem vowel in column B, the form of such a vowel is recoverable from forms such as those in column C, where a suffix has been added.

(61)	A	B	C	
	yeme	yem	yemen	'accept'
	ɔro	ɔr	ɔron	'say'
	kere	ker	keren	'seek'
	ngohoro	ngohor	ngohoron	'accept'

It is now possible to account for the generalizations in (48); First, contour tones occur only in word-final position because the language specific rule (T-attachment) that creates them is restricted

to applying in word-final position. Second, falling and rising tones are possible on CVC syllables because V-deletion (58) feeds T-attachment (54). Consider the derivations of kêr 'seek!' and bě̃r 'pond':

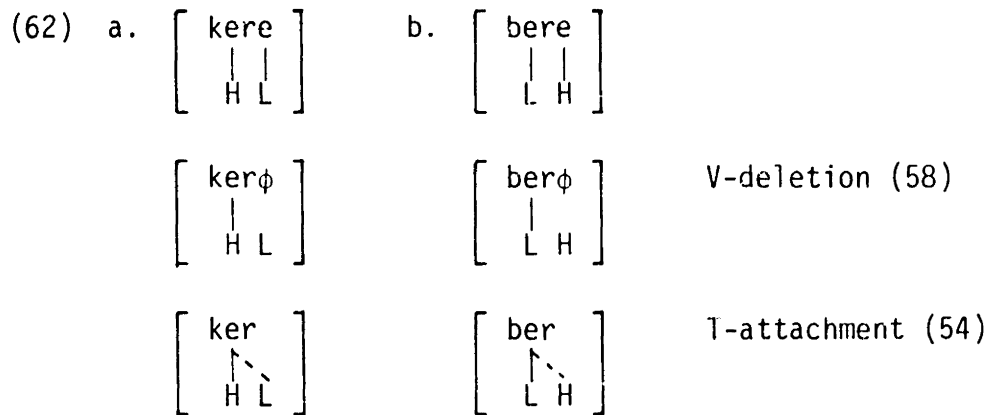

We are left only with the problem of allowing falling tones -- but blocking rising tones -- on CV syllables. This problem receives a simple explanation when we consider the rule of Raising (34), repeated here as (63):

(63) Raising: $L \rightarrow H / \text{ ___ } \textcircled{H}$

We saw above that in the Recent Past, a configuration such as in (64a) will be changed into (64b) by the rule of Raising.

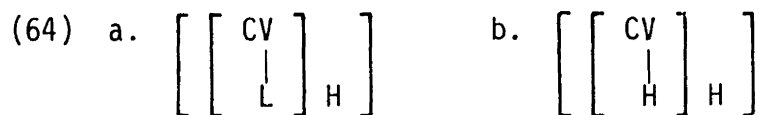

If Raising is ordered before T-attachment, we correctly predict that

rising tones are impossible on CV syllables. This is because the application of T-attachment to a configuration like in (64b) -- the output of Raising -- will be a level H-tone. Notice that there is no rule comparable to Raising that would affect a H(L) sequence. This correctly predicts that T-attachment will derive falling tones on CV syllables in such cases.

As a final point, Raising must be ordered before V-deletion to keep it from wiping out potential rising tones on CVC syllables. Consider, for example, the derivation of the Recent Past form kũm 'roared (recently)'. On the stem cycle, the Association Conventions (44) apply:

(65) a. $\left[\begin{array}{c} \text{kume} \\ \vdots \\ \text{L} \end{array} \right]$ Cycle 1: Association Conventions (44)

When the Recent Past suffix is added, the Association Conventions (44) and Ablaut apply:

b. $\left[\left[\begin{array}{c} \text{kume} \\ | \\ \text{L} \end{array} \right] \text{H} \right]$ Cycle 2: Association Conventions (44)

c. $\left[\left[\begin{array}{c} \text{kumu} \\ | \\ \text{L} \end{array} \right] \text{H} \right]$ Ablaut

Crucially, if Raising is ordered so as to apply at this point of the derivation, it will be inapplicable in a case like (65). Subsequently, in what we will see later to be part of the post-lexical derivation, V-deletion and T-attachment apply:

d. $\left[\begin{array}{c} \text{kum}\phi \\ | \\ \text{L H} \end{array} \right]$ V-deletion (58)

e. $\left[\begin{array}{c} \text{kum} \\ | \quad \diagdown \\ \text{L H} \end{array} \right]$ T-attachment (54)

If Raising (34) was ordered after V-deletion, then *kúm would incorrectly be derived.

In conclusion, I have proposed that contour tones in Tiv are the result of a late rule of T-attachment. By ordering T-attachment after V-deletion, and V-deletion after Raising, we correctly account for the appearance of rising tones on CVC syllables but not on CV syllables. Falling tones are possible on both CV and CVC syllables since no rule comparable to Raising exists to affect a H-tone before a floating L-tone. And the above analysis means that the tone-bearing unit in Tiv is simply the V-slot -- or equivalently, the core slot that is the syllable nucleus.

4.2 Lexical constraints (continued)

Returning to the main topic of this section, I wish to propose two lexical constraints for Tiv -- the first concerning possible syllables, and the second concerning possible linkings of tones.

- (66) Syllables of Tiv: 1. A rime may not branch.
 2. An onset may not branch. ¹⁶

The effect of (66) is that syllables in the lexicon may only be V or CV. Any rule whose effect is to create a syllable other than those allowed by (66) must therefore be a post-lexical rule.

This means that the rule of V-deletion (58) must apply post-lexically. Note that this predicts that V-deletion will also exhibit other properties of post-lexical rules, and we will see below that this is the case.

Next, I proposed the following constraint on tone association.

(67) Tones of Tiv: $\begin{array}{c} * \\ \text{V} \\ \diagup \quad \diagdown \\ \text{T} \quad \text{T} \end{array}$

This constraint states that no more than one tone can be linked to a single tone-bearing unit in Tiv. As has been assumed elsewhere in this thesis, I follow Goldsmith (1976) in assuming that such constraints do not prevent a rule from applying if its output would be ill-formed; rather, association lines are added or deleted in the minimal way that will create a well-formed representation.

The constraint in (67) requires that T-attachment (54) apply post-lexically. This is because the contour tone that T-attachment creates is in violation of the lexical constraint on one-to-one linkings.

Constraint (67) also suggests that the rule of H-spread operates lexically. The delinking of a L-tone that results from H-spread (38) follows automatically if the rule applies lexically, since a multiple association would violate the one-to-one constraint. On the other hand,

if H-spread were to apply post-lexically, then the delinking of the L-tone would have to be stipulated in the rule.

The status of constraints such as (66) and (67) is an interesting question. Can they, for example, be derived from a principle of 'structure preservation' (Kiparsky 1982) in the lexicon? To exploit the notion of structure preservation in deriving (67), for example, one could propose the following: In underived lexical entries in Tiv, there are no tone-bearing units linked to more than one tone. Consequently, no rule applying in the Tiv lexicon could create such a linking.¹⁷ Some degree of unpredictability does appear to exist however. In Tiv, the one-to-one constraint holds lexically but not post-lexically. In Dschang, on the other hand, a one-to-one constraint was seen in chapter 2 to hold both lexically and post-lexically. The difference in post-lexical behaviour could not follow from a principle of structure preservation. Moreover, Mohanan and Mohanan (1983) have shown that there are problems with the notion of structure preservation. In Malayalam, they argue that the inventory of segments at the output of the lexicon includes certain segments not present in underived lexical entries.

This thesis will not attempt to resolve the issue of structure preservation. It is noteworthy, however, that the underlying inventory of linkings (ie. one-to-one) is the same as the inventory of linkings at the output of the lexicon.

assignment to strata are correct for the rules concerned.

The rules that I will discuss are the following:

$$(69) \text{ a. Raising: } L \rightarrow H / \text{ ___ } \textcircled{H} \quad (34)$$

$$\text{b. H-spread: } \begin{array}{c} \text{V} \quad \text{V} \\ | \quad | \\ \text{H} \text{---} \text{L} \end{array} \quad (38)$$

$$\text{c. T-attachment: } \left[\begin{array}{c} \text{V} \quad (\text{C}) \\ \vdots \\ \textcircled{\text{T}} \end{array} \right] // \quad (54)$$

$$\text{d. V-deletion: } \left[\begin{array}{c} [+son] \\ | \\ \text{C} \\ / \quad \backslash \\ \text{V} \quad \text{V} \\ \backslash \quad / \\ [\alpha F] \end{array} \right] \rightarrow \left[\begin{array}{c} [+son] \\ | \\ \text{C} \\ | \\ \text{V} \\ | \\ [\alpha F] \end{array} \right] \quad (58)$$

First, look at Raising. Consideration of a Past Habitual form such as !dzaân 'used to go' shows that Raising must apply cyclically.

On the stem cycle, the lexical L of dza associates:

$$(70) \text{ a. } \left[\begin{array}{c} \text{dza} \\ \vdots \\ \text{L} \end{array} \right]$$

On the second cycle, the habitual -H suffix is added:

$$\text{b. } \left[\left[\begin{array}{c} \text{dza} \\ | \\ \text{L} \end{array} \right] \text{H} \right]$$

Since the H of the suffix cannot link, Raising is triggered:

$$c. \quad \left[\left[\left[\begin{array}{c} dza \\ | \\ H \end{array} \right] H \right] \right]$$

Subsequently, a second habitual suffix is added, namely $\left[\begin{array}{c} n \\ | \\ L \end{array} \right]$. The allomorph of this suffix for a monosyllabic stem is $\left[\begin{array}{c} -Vn \\ | \\ L \end{array} \right]$: (for the sake of clarity, I assume the full three-dimensional representation here that includes the core.)

$$d. \quad \left[\left[\left[\left[\begin{array}{c} dza \\ | \\ C \quad V \\ | \\ H \end{array} \right] H \right] \left[\begin{array}{c} n \\ | \\ V \\ | \\ L \end{array} \right] \right] \right]$$

In (70d), the Association Conventions have applied to link the free tones to the free V-slots. In (70e), we see the application of a rule that is not discussed in this thesis, namely a rule that spreads the features of the stem vowel onto the empty V-slot of the suffix. ¹⁸

$$e. \quad \left[\left[\left[\left[\begin{array}{c} dza \\ | \\ C \quad V \\ | \\ H \end{array} \right] H \right] \left[\begin{array}{c} n \\ | \\ V \\ | \\ L \end{array} \right] \right] \right]$$

Lastly, the [L- prefix of the General Past is added, creating an initial downstep:

$$f. \quad \left[L \left[\left[\left[\left[\begin{array}{c} dza \\ | \\ H \end{array} \right] H \right] a \right] \left[\begin{array}{c} n \\ | \\ L \end{array} \right] \right] \right]$$

The crucial aspect of the above derivation is the cycle on which the -H] suffix is added. Raising (34) will only be triggered if the H cannot link. Under a cyclic analysis, this is in fact the situation found on the second cycle since the $- \begin{matrix} Vn \\ L \end{matrix}]$ suffix is not yet present. The -H] of the habitual floats and Raising is triggered.

If Raising were only to apply post-lexically, then we would predict * dzaân for such a case:

$$(71) \quad \left[\begin{matrix} L \\ \left[\left[\left[\begin{matrix} dza \\ L \end{matrix} \right] H \right] \begin{matrix} V \\ n \end{matrix} \right] \right] \right]$$

Note also that if tone association were non-cyclic, then we would have a comparable problem.

Since Raising applies cyclically, it must apply lexically. There is a further question, however. If Raising applies lexically, can it also apply post-lexically? The relevant cases are those discussed in section 4.1, concerning the derivation of rising tones. In example (65), it was shown that V-deletion must not feed Raising. While this could be accounted for by assigning Raising to the lexical stratum, and V-deletion to the post-lexical stratum, it would also be possible to assume that Raising applied at both strata but was ordered in the list of phonological rules to apply before V-deletion:

Conventions apply to give the configuration in (73a).

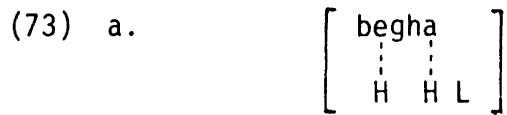

If T-attachment (54) were to apply lexically, then the one-to-one constraint (67) would automatically delink the H-tone, giving us:



Incorrectly, lexical application of T-attachment would derive *béghà. On the other hand, if T-attachment only applies post-lexically, then the correct results are obtained in such a case, because the one-to-one constraint does not hold post-lexically:



Finally, as far as V-deletion is concerned, it must apply post-lexically since it creates a syllable violating the lexical constraint prohibiting branching rimes (66).²⁰ Note, however, that there is no particular reason to restrict the domain of V-deletion to the post-lexical stratum, since the constraint on branching rimes will block its application lexically, independent of a domain specification.

To summarize, the principles of lexical phonology, in conjunction with the two lexical constraints given in (66) and (67), combine to require the following assignment to strata of the four rules considered in this section:

(74)	Lexical	Post-lexical
Raising	yes	??
H-spread	yes	no
T-attachment	no	yes
V-deletion	??	yes

The question marks in (74) indicate cases where there is no evidence for the application of the rule in question in that component; but allowing the rule to be assigned to that domain would not necessarily create undesirable results.

The assignment of rules to domains given in (74) makes a number of predictions. In the derivation of some word, if two rules apply, and one has been determined by the principles of lexical phonology to apply lexically, and the other has been determined to apply post-lexically, then the rule applying lexically must apply first.

Consider, for example, the interaction of H-spread and V-deletion in the derivation of a verb such as vé k á v 'they've understood'. This form consists of a third person plural subject prefix, a verb stem, and a Recent Past suffix:

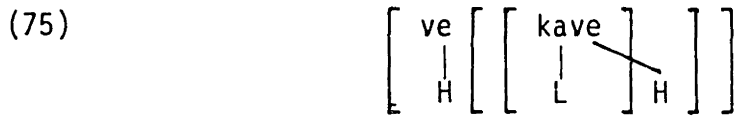

In (76), I illustrate the results of applying H-spread and V-deletion, in both possible orders:

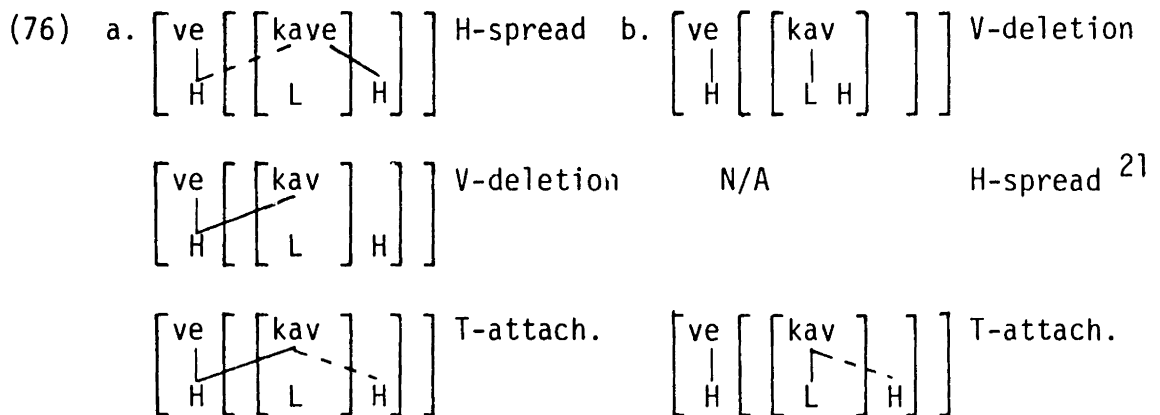

Clearly, the correct results are obtained by ordering H-spread before V-deletion, as predicted in (74). The derivation assuming this order correctly derives a H-to-downstepped-H contour on kav. If, on the other hand, V-deletion were to precede H-spread (as in 76b), then we would derive either * vé káv or * vé kǎv, depending on whether Raising applied.

A case such as vé k^áv constitutes a strong argument for the approach being taken here since the complex H-to-!H contour is derived with no special rules or stipulations.

As a second case, let us consider the relation between Raising and T-attachment. In a linked-L floating-H sequence such as in (77), both Raising and T-attachment are applicable -- as far as the

structural descriptions of the two rules are concerned.

$$(77) \quad \left[\left[\begin{array}{c} \text{dze} \\ | \\ \text{L} \end{array} \right] \text{H} \right]$$

If Raising applies before T-attachment -- the order forced upon us by the assignment of domains given in (74) -- then we derive the correct result, namely dzé. On the other hand, if T-attachment were to apply first, then its application would bleed Raising, and we would incorrectly end up with dzě.

To conclude this section, I have shown that the ordering of a number of rules required for the tonal grammar of Tiv falls out automatically from their assignment to strata. Extrinsic ordering of rules is not eliminated by the theory of lexical phonology, but the role that extrinsic ordering must play is reduced considerably. This result has obvious implications for the learnability of a grammar. By determining certain properties of a rule that would assign it to a given stratum, a learner is already determining its relative ordering with respect to rules assigned to other strata.

6. Derived vs. nonderived

Consistent with the assignment of Raising and H-spread to the lexical stratum is the fact that in all cases where they have applied above, the structural description was derived on the cycle on which the rule applied. Some typical cases include examples (9-11), (33), (42-43), (70) and (76).

The derived vs. nonderived distinction also provides additional evidence that V-deletion is post-lexical, since that rule applies in a non-derived environment. In (78a) and (78b), for example, the addition of a suffix in (78b) blocks V-deletion (58), while in (78a), the absence of any suffix results in the application of V-deletion.

- (78) a. ká tɔl 'it is a pestle'
 b. ká tɔlɔ̀ 'is it a pestle?'

In order for suffixation to block V-deletion from applying to the stem tɔlɔ̀ in (78b), V-deletion must apply after affixation processes -- that is, V-deletion must apply post-lexically.

Although I will not discuss in detail the problems inherent in requiring all rules applying lexically to apply only in derived environments, it is worth pointing out that all the rules discussed in this thesis that crucially apply lexically, do in fact apply in derived environments. In most cases, what constitutes a derived environment is definable morphologically in the cases seen in this thesis. For example, Raising becomes applicable in (77) because of the addition of an affix. In a number of cases, however, the environment of a rule is derived by the application of the Association Conventions. For example, in Margi, the rule of Tone-spreading is triggered by the application of the Association Conventions in a case like dzà'ùbá 'to pound well'. If we compare the underlying form of the stem, with the rule of Tone-spreading, we see that the structural description of Tone-spreading is not met underlyingly:

(79) $\left[\begin{array}{c} \text{dza}'\text{u} \\ \text{L} \end{array} \right]$

(80) Tone-spreading: $\begin{array}{c} \text{V} \quad \textcircled{\text{V}} \\ | \quad \text{---} \\ \text{T} \end{array}$

However, once the Association Conventions have applied on the first cycle, the derived representation meets the structural description of Tone-spreading:

(81) $\left[\begin{array}{c} \text{dza}'\text{u} \\ | \\ \text{L} \end{array} \right]$

7. Default rules

It has been proposed that toneless vowels in Tiv are assigned default L-tones according to the theory of underspecification discussed in some detail in chapter 3. In this section, I will discuss two issues related to such default rules. The first concerns the status of default tones as autosegments. The second concerns the determination of where default rules apply.

In chapter 1, I discussed briefly an alternative to viewing default tones as autosegments. In the approach of Halle and Vergnaud (1982), default tones consisted of a 'core' specification, where such a core specification would only surface if no tonal autosegment had been assigned.

In Tiv, there is evidence that supports the autosegment approach proposed in chapter 3 of this thesis. Consider a Recent Past form such as ngòhòr 'accepted (recently)':

- (82) $\left[\begin{array}{c} \text{ngohoro} \\ \vdots \\ \underline{L} \end{array} \right]$ Cycle 1: Stem; Association Conventions
- $\left[\left[\begin{array}{c} \text{ngohoro} \\ \vdots \\ \underline{L} \end{array} \right] \text{H} \right]$ Cycle 2: Recent Past Suffix; Association Conventions

The form in (83a) shows what the input to V-deletion would be if we assume the default L is a core specification; (83b) shows the form that would result if default autosegments were assigned.

- (83) a. $\left[\begin{array}{cc} \text{ngoho} & \text{ro} \\ | & | \\ \underline{L} & \text{H} \end{array} \right] \begin{array}{l} \\ \\ \text{[+L]} \end{array}$ b. $\left[\begin{array}{ccc} \text{ngohoro} \\ | \quad | \quad | \\ \underline{L} \quad \text{H} \quad \underline{L} \end{array} \right]$

In (83a), deletion of the final vowel would entail deletion of the core tonal specification; in (83b), on the other hand, deletion of the final vowel would simply result in a floating L-tone. Clearly, (83b) correctly predicts the configuration that will result in a falling contour on the last syllable of ngòhòr (after T-attachment); equally clearly, (83a) predicts a level H-tone after V-deletion.

I conclude therefore that default values of autosegmentally represented features are themselves autosegments. And if all features are in effect autosegmental, as suggested in chapter 1, then all default feature values are autosegmental in nature.

The last issue concerning default rules is where they apply. Clearly, the most restrictive position that one could take would be to assume that a) default rules cannot be extrinsically ordered among language-specific phonological rules, and b) the component in which default rules apply is predictable.

I will begin addressing these questions by summarizing the basic results of this thesis. In Tiv, it is crucial that Default L-insertion does not apply cyclically. The whole analysis of this chapter depends on delaying the insertion of default L-tones until after all process of affixation. Consider the example in (82). Default tones must not be inserted until after the addition of the Recent Past suffix. It is also crucial for an example like (82) that Default L-tones be inserted prior to the post-lexical application of V-deletion and T-attachment. In general, it can be established for Tiv that Default L-insertion applies after all lexical rules and before all post-lexical rules.

Turning to a language like Yoruba, discussed in chapter 3, we find a situation that is somewhat different. As in Tiv, the rules that insert default tones must not apply lexically. But unlike Tiv, certain post-lexical rules must apply prior to the insertion of default M-tones. What is striking about the Yoruba case is that no post-lexical rule makes reference to the default tone; the only rules that refer to M-tones are rules of the phonetic component, for example, the rule creating downstepped M-tones. Hence it would be possible to characterize Default M-insertion in Yoruba as

applying after all post-lexical rules but before all phonetic rules.

Margi employs default tone-insertion to a more limited extent than either Tiv or Yoruba. It was shown in chapter 5 that Default L-insertion applies principally on two occasions: 1) when no tone has been assigned to a word by the lexical morphology and phonology 2) when a constituent loses its extratonicity at a late stage of the post-lexical derivation. As in Yoruba, it is crucial that Default L-insertion does not apply lexically (since in Margi, suffix tones link cyclically to toneless stems), but strikingly, no post-lexical rules crucially involve default tones. There are two basic ways to capture the Margi facts. One would be to say that Default L-insertion applies at the beginning of the post-lexical derivation and that it reapplies when extratonicity is lost. That is, within a single derivation, default tones can be assigned at more than one point. Alternatively, default tones in Margi could be assigned after all post-lexical rules but before phonetic rules (as in Yoruba). Under this view, one could analyse loss of extratonicity and assignment of default L-tones as rules of the phonetics.

In Dschang, no particular case was made in chapter 2 for default tones. It would be perfectly conceivable for Dschang, however, that Default L-insertion applies lexically. Since no lexical rules affecting tone were discussed in the section on Dschang, there is no conclusive way of showing that certain 'lexical' L-tones either are, or are not, assigned by default rules.

In the above paragraphs, I have narrowed default tone assignment down to applying 'after component X' but 'before component Y'. For example, in Tiv, the default rules apply after the lexical derivation but before the post-lexical derivation. This type of distribution could be accounted for in two ways: 1) default rules could be assigned to the end of a stratum 2) default rules could be assigned to the beginning of a stratum. Consider again the case of Tiv. Two strata have been motivated in this chapter, a lexical stratum and a post-lexical stratum. If default rules were assigned to the beginning of the post-lexical stratum, then the correct results would be obtained without problem. On the other hand, assigning default rules to the end of the lexical stratum creates some complications. It has been seen above that phonological rules assigned to the lexical stratum of Tiv apply cyclically. Consider, for example, the case of Raising in the derivation in (70). But it is crucial that Default L-insertion not apply cyclically in Tiv. So if default rules are assigned to the end of strata, then some additional stipulation will be required for Tiv. For example, one might assume an otherwise unmotivated additional stratum. Or one might assume a 'word-level' application of rules. However, since no complications result from assuming that default rules are assigned at the beginning of the post-lexical stratum, I will opt for that solution here.

Given the assumption that default rules apply at the beginning of the stratum to which they are assigned, I summarize in (84) the results discussed so far:

(84)	Yoruba	Margi	Tiv	Dschang
Lexical:	X	X	X	↓
Post-lexical:	X	(↓)	↓	(↓)
Phonetic:	↓	↓	(↓)	(↓)

An arrow in (84) indicates that default tones are assigned at that level. Brackets indicate that default tones could be assigned at that level without ill effects, although there is no particular evidence for such assignment. One interesting point about (84) is that I have found no strong evidence for default rules applying at more than one level. But the facts are perfectly consistent with a proposal where the parameter for default rules would be to set the earliest point where they can apply, allowing free application of default rules at all points after that.

To conclude this section, I will discuss briefly the somewhat more complex situation seen in chapter 5 to hold for Tonga. Default L-insertion must not apply lexically in Tonga, since lexical application of Default L-insertion would bleed the post-lexical application of H-spread (see, for example, figure 44 in chapter 4). The same example demonstrates that Default L-insertion must apply post-lexically, since it feeds post-lexical application of Downstep Creation. Hence it is established that default tones are assigned post-lexically. Note, however, that if default tones are assigned at the very beginning of the post-lexical derivation, such application would bleed post-lexical application of H-spread just as much as

if default tones had been assigned lexically. Hence, even though Default L-insertion must apply post-lexically, it must be ordered to apply after H-spread.

It turns out, however, that this result can be obtained without extrinsic ordering of the two rules. With regards to the Elsewhere Condition, the structural description of H-spread properly contains the structural description of Default L-insertion.

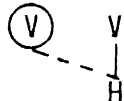
(85) H-spread (Tonga): 

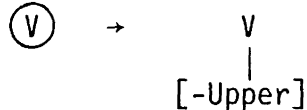
(86) Default L-insertion: 

Following a suggestion by Paul Kiparsky, I assume therefore that default rules are subject to the Elsewhere Condition. This means that in the case of the two rules in (85) and (86), H-spread will be ordered before Default L-insertion by the principles of disjunctivity.

There is still one problem for Tonga, however. The same derivation referred to above shows that Default L-insertion must apply after the post-lexical rule of Delinking -- but in this case, the two rules are not in an Elsewhere relationship, and therefore disjunctivity cannot derive the required ordering. It is still possible, however, to avoid extrinsic ordering of default rules.

The relationship between Default L-insertion and Delinking is quite different than the relationship between Default L-insertion and H-spread. While in both cases, Default L-insertion must apply after application of the other rule, in the case of Delinking, it makes no difference whether L-insertion also takes place before Delinking. I take this as evidence, therefore, that once default rules begin to apply, they apply throughout the derivation wherever they can. In Tonga, this means that Default L-insertion begins its application at the post-lexical stratum; the Elsewhere Condition requires that assignment of default tones be held off until after the application of H-spread, but once H-spread has applied, Default L-insertion applies everywhere that it can.

The final question about default rules concerns the predictability of the component in which they apply. On the basis of the results summarized in (84), it is not clear that one can predict completely where such rules will apply. There appear to be two important considerations. First, the constraint on underspecification given in figure (70) of chapter 3 requires that default rules be assigned to any stratum on which rules refer to the feature value assigned by the default rule. For example, default tones can be assigned in the phonetic component of Yoruba because no post-lexical rules refer to the default value. In Tonga, on the other hand, default tones must be assigned post-lexically because the post-lexical rule of Downstep Creation refers to the default value. Such considerations

define a point in the grammar after which representations will be ill-formed if default rules have not applied. On the other side of the coin, if a language specifies only one value of a feature in its lexical representations -- that is, there are no environments in which the second value is underlyingly specified -- then lexical constraints might prevent the assignment of the default value until the post-lexical stratum or later. Considerations of this nature would determine a point in the grammar before which default rules could not apply.²²

By defining points in the grammar before which default rules could not apply, and after which default rules must have applied, one does not uniquely define the stratum on which default rules apply. On the other hand, one does restrict the possibilities to a small subset of the possible strata.

8. Lexical exceptions

As mentioned in chapter 1, Mohanan (1982) proposes that the existence of lexical exceptions to a rule suggests that the rule in question is lexical. In this section, I will discuss two such cases.

8.1 The Future Tense

The Future tense morpheme constitutes a case that violates left-to-right association of tones. The marker of the Future is an

[a- prefix that bears a LHL tonal pattern. Contrary to expectation, however, the initial L of the LHL pattern does not link to the vowel a -- rather, it is the H that links, resulting in the surface form given in (87b) for a representation such as that in (87a).

- (87) a.
$$\left[\begin{array}{c} \text{ve} \\ | \\ \text{H} \\ \text{3rd pl.} \\ \text{subject} \end{array} \left[\begin{array}{c} \text{a} \\ | \\ \text{L H L} \\ \text{future} \end{array} \left[\begin{array}{c} \text{va} \\ | \\ \text{H} \\ \text{stem} \end{array} \right] \right] \right]$$
- b. vé !á! vá 'they will come'

Clearly, the linking shown in (87a) cannot be the result of conventions. I propose therefore that the lexical representation of the future morpheme is as in (88).

- (88) Future:
$$\left[\begin{array}{c} \text{a} \\ | \\ \text{L H L} \end{array} \right]$$

As discussed extensively in chapter 4, lexical linking is being used to encode exceptions to the general association conventions.

Note that in order for tones to be prelinked in the lexicon, they must be present in the lexicon. Hence tenses like the Future provide an additional argument for the lexical representation of tone in a language like Tiv. In a stress-type language, where tones are only assigned post-lexically or phonetically, it would be impossible to assign an unusual tone pattern like !H! in the underlying representation of a morpheme.

8.2 !-deletion

There is a problem with the above, however, when we consider the complete set of Future forms:

(89) Future

	<u>H-stem</u>		<u>L-stem</u>	
1 syllable:	!á vá !H!H will come		!á dzà !HL will go	
2 syllable:	!á úngwà !HHL will hear		!á vèndè !HLL will refuse	
3 syllable:	!á yévèsè !HLLL will flee		!á ngòhòrò !HLLL ²³ will accept	

Looking first at the L-stem forms, we see that the second L of the Future prefix -- posited to account for the downstepping in (87) -- correctly blocks H-spread from applying in the L-stem forms:

(90)	$\left[\begin{array}{c} \text{vende} \\ \vdots \\ \underline{L} \end{array} \right]$	Cycle 1: Stem; Association Conventions
	$\left[\begin{array}{c} \text{a} \\ \\ \underline{L} \text{ H } \underline{L} \end{array} \left[\begin{array}{c} \text{vende} \\ \\ \underline{L} \end{array} \right] \right]$	Cycle 2: Future Prefix

As in the General Past (see section 1.2), H-spread does not apply because it only spreads a H onto an immediately adjacent linked L.

But turning to the H-stem forms, we observe that the downstep occurring between the a and the stem has been lost in disyllabic and trisyllabic forms. I propose that these cases be looked after

by a rule of downstep deletion, but I will postpone formulating the rule until after consideration of a second class of problems concerning the effect of H-spread.

We have seen above that because of H-spread, the H of a subject prefix will spread onto the first vowel of a L-stem verb such as vende in a tense like the Recent Past:

- (91) $\left[\begin{array}{c} \text{vende} \\ \vdots \\ \text{L} \end{array} \right]$ Cycle 1: Stem; Association Conventions
- $\left[\left[\begin{array}{c} \text{vende} \\ | \quad \diagdown \\ \text{L} \quad \text{H} \end{array} \right] \right]$ Cycle 2: Recent Past Suffix; Association Conventions
- $\left[\begin{array}{c} \text{ve} \\ \vdots \\ \text{H} \end{array} \left[\left[\begin{array}{c} \text{vende} \\ | \quad \diagdown \\ \text{L} \quad \text{H} \end{array} \right] \right] \right]$ Cycle 3: 3rd pl. subject prefix; Association Conventions
- $\left[\begin{array}{c} \text{ve} \\ | \\ \text{H} \end{array} \left[\left[\begin{array}{c} \text{vende} \\ | \quad \diagdown \\ \text{L} \quad \text{H} \end{array} \right] \right] \right]$ H-spread (8)

The reader may have noticed that this particular type of spreading example has always been with a disyllabic verb stem. There are two reasons for this: 1) H-spread could not apply to a monosyllabic, unsuffixed verb stem, since it only spreads a H onto a non-final L-tone. (See footnote 21) 2) There is a complication in the trisyllabic forms. I now turn to this complication.

Consider the Recent Past form vê ngôhôr 'they accepted (recently)':

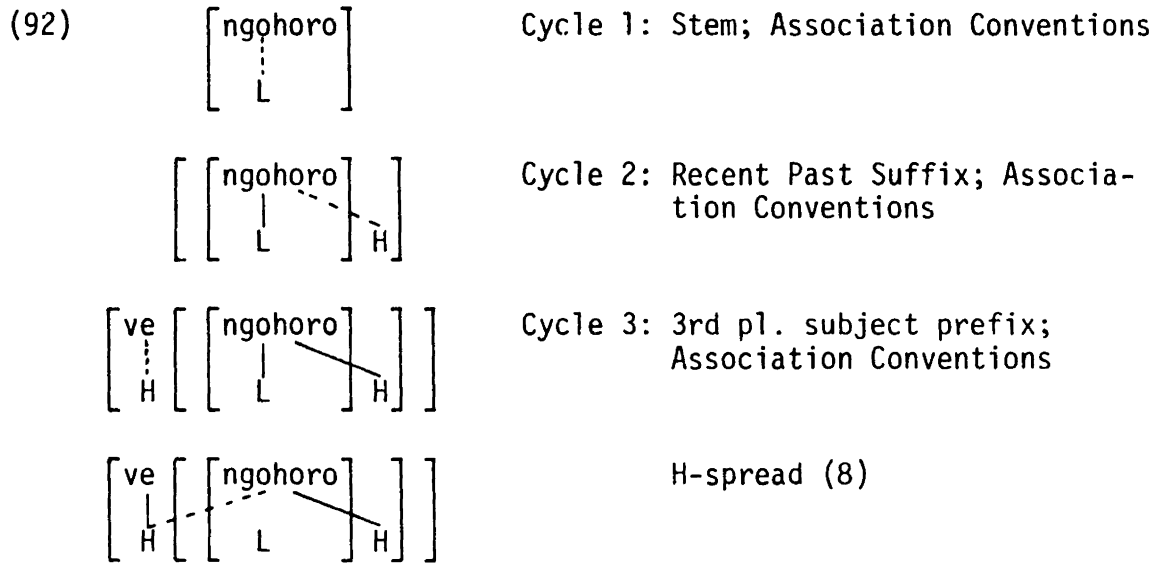

Given the representation in (92), we would predict that after V-deletion (58) and T-attachment (54), we would get the surface form * vé ngó[!]hôr instead of the correct vé ngóhôr.

This example is interesting for two reasons: 1) The fact that the initial stem vowel of ngohoro -- a L-stem verb -- is H shows clearly that H-spread has taken place. 2) The fact that there is no downstep -- unlike with vé vé[!]ndé -- shows that a rule must have deleted the floating L in such a case.

By comparing the forms that trigger downstep-deletion with those that do not, we observe the following.



The forms that do not trigger downstep-deletion (vé vé[!]ndé (91) and vé[!]á[!]vá (87)) have the configuration given in (93a); the forms that

do trigger downstep-deletion (vé ngóhôr (92) and vé!á úngwà, vé!á yévèsè (89)) have the configuration given in (93b). The circle in (93b) indicates that the V-slot has no tone linked to it.

I therefore propose to formulate a rule of downstep-deletion as in (94).

(94) !-deletion (first formulation):

$$\textcircled{L} \rightarrow \phi / \text{---} \begin{array}{c} \text{V} \\ | \\ \text{H} \end{array} \textcircled{V}$$

This rule will take a configuration such as in (95a) and create the form in (95b):

(95) a.
$$\left[\begin{array}{c} a \\ | \\ L \ H \ L \end{array} \left[\begin{array}{c} \text{yevese} \\ | \\ H \end{array} \right] \right]$$

b.
$$\left[\begin{array}{c} a \\ | \\ L \ H \end{array} \left[\begin{array}{c} \text{yevese} \\ | \\ H \end{array} \right] \right]$$

Default L-insertion will then apply to give the correct surface form.

This approach can in fact be extended to account for an additional, and previously unexplained, fact about the Habitual 1. It was observed earlier (footnote 11) that in the Habitual 1, the floating [L- prefix of that tense is lost before a trisyllabic H-stem verb. I will not give detailed derivations here, but in (96), the various H-stem forms that we would have in the Habitual 1 just prior to the rule of !-deletion are illustrated.

- (96) a. $\left[\begin{array}{c} L \left[\left[\begin{array}{c} va \\ | \\ H \end{array} \right] H \right] \end{array} \right]$
- b. $\left[\begin{array}{c} L \left[\left[\begin{array}{c} ungwa \\ | \\ H \end{array} \right] H \end{array} \right] \right]$
- c. $\left[\begin{array}{c} L \left[\left[\begin{array}{c} yevese \\ | \\ H \end{array} \right] H \end{array} \right] \right]$

By generalizing (94), !-deletion can be reformulated so as to delete the downstep in (96c) while leaving intact the downsteps in (96a) and (96b):

- (97) !-deletion:
- $$\textcircled{L} \rightarrow \phi / \text{---} \begin{array}{c} V \\ | \\ H \end{array} \left(\begin{array}{c} V \\ | \\ H \end{array} \right) \textcircled{V}$$

To summarize, I propose that the rule of !-deletion accounts for a number of morphologically unrelated cases where floating L-tones are deleted. And this brings me to the problem: Why does !-deletion not delete the floating [L- prefix of the General Past? Both !úngwà 'heard' and !yévéèè 'fled' meet the structural description of the rule.

- (98) a. $\left[\begin{array}{c} L \left[\begin{array}{c} ungwa \\ | \\ H \end{array} \right] \end{array} \right]$ b. $\left[\begin{array}{c} L \left[\begin{array}{c} yevese \\ | \\ H \end{array} \right] \end{array} \right]$

I propose that the General Past prefix [L- be lexically marked as an exception to !-deletion. This means that !-deletion must itself

be lexical since it has lexical exceptions, and it means that tone association must be lexical since !-deletion must crucially distinguish between linked and floating tones.

9. Extratonicity

The Imperative tense and the Subjunctive tense are somewhat problematic. In the case of the Imperative, we observe what appears to be tonal polarity in cases like úngwà 'hear!' and vèndá 'refuse!'. In the case of úngwà, the stem is H and the final stem vowel is L in the Imperative; in the case of vèndá, the stem is L and the final stem vowel is H in the Imperative. Turning to the Subjunctive, we observe what appears to be the effect of H-spread in a case like vè vé!ndá 'they are to refuse', but the subject prefix is unexpectedly on a L-tone. The tonal behaviour of both these tenses can be explained in terms of extratonicity.

9.1 Imperative

The full set of Imperative forms is given in (99) below:

(99) Imperative

	<u>H-stem</u>		<u>L-stem</u>	
1 syllable:	vá come!	H	dzá go!	H
2 syllable:	úngwà hear!	HL	vèndá refuse!	LH
3 syllable:	yévésè flee!	HHL	ngòhórò ²⁴ accept!	LHL

This tense has been problematic for all earlier analyses of Tiv. First of all, there is some question as to what the facts are. The forms given in (99) are those found in Arnott (1964). The forms found in Abraham (1940b) are somewhat different for the trisyllabic verb stems. Abraham distinguishes between two distinct patterns, depending on whether the stem undergoes V-deletion or not. For the stems that undergo V-deletion, Abraham gives the same tonal forms as Arnott. But where V-deletion is inapplicable, Abraham lists forms like the following:

- (100) a. H-stem: yévé^è 'flee!' HLL
 b. L-stem: kèngè^é 'chew cud!' LLH

If such forms are correct, I have no explanation for them.

Secondly, even for those forms given by Arnott, finding a satisfactory solution has proven difficult. For example, the solution proposed by Arnott was the following:

- (101) monosyllabic stem: H
 disyllabic stem: V + opp
 trisyllabic stem: V H L

Given in (101) are the tonal formulas for the Imperative tense, where the 'V' refers to the lexical tone, whether H or L. The unfortunate aspect of Arnott's analysis is that he was forced to posit three distinct tonal formulas for a single tense, where the choice of formulas depended on counting the number of syllables in the verb stem.

Goldsmith (1976) offered two possible analyses. The first was that of Arnott, and the second collapsed the three melodies into two, and required a patch-up rule. Clearly, something is happening in this tense that is not captured in a melody approach.

What I wish to propose here is that the basic marker of the Imperative is a -H] suffix. In fact, given the analysis of this chapter, that is all we need to say for all but the disyllabic H-stem verbs. For example, with trisyllabic stems, the lexical tone will link to the first vowel, the -H] suffix will link to the second vowel, and the third vowel will receive a L-tone by default. We therefore correctly derive HHL and LHL patterns for trisyllabic verb stems. As for the monosyllabic L-stem verbs that surface as H, Raising will account for the H in the Imperative just as it does in tenses like the Recent Past. (See section 3.1)

A solution to the disyllabic H-stem cases is possible if we assume a rule assigning extratonicity to the final vowel of an imperative form:

(102) Extratonicity (Imperative):

$$V \rightarrow \begin{matrix} V \\ [+ex] \end{matrix} / \text{ — IMPERATIVE]}$$

Consider the application of this rule in the derivations of úngwà and vèndá. On the first cycle, the stem tone will associate by convention in each case; on the second cycle, the H of the Imperative suffix will also link by convention.

- (103) a. $\left[\begin{array}{c} \text{ungwa} \\ \vdots \\ \text{H} \end{array} \right]$ b. $\left[\begin{array}{c} \text{venda} \\ \vdots \\ \text{L} \end{array} \right]$ Cycle 1: Stem; Association Conventions
- $\left[\left[\begin{array}{c} \text{ungwa} \\ \vdots \\ \text{H} \end{array} \right] \text{H} \right]$ $\left[\left[\begin{array}{c} \text{venda} \\ \vdots \\ \text{L} \end{array} \right] \text{H} \right]$ Cycle 2: Imperative Suffix; Assoc. Conv.

On the second cycle, the final vowel in each case will be marked extratonal by rule (102). I assume that such marking automatically entails the dissociation of the extratonal vowel from any tone to which it had been previously linked, since an association line to an 'invisible' core slot would seem to contradict the intention of extratonicity: ²⁵

- (104) Dissociation Convention:
$$\begin{array}{c} \text{V} \\ [+ex] \\ \neq \\ \text{T} \end{array}$$

Hence after marking of extratonicity, we derive the representations in (105):

- (105) a. $\left[\left[\begin{array}{c} \text{un} \\ \vdots \\ \text{H} \end{array} \right] \left[\begin{array}{c} \text{gwa} \\ [+ex] \end{array} \right] \right] \text{H}$ b. $\left[\left[\begin{array}{c} \text{ve} \\ \vdots \\ \text{L} \end{array} \right] \left[\begin{array}{c} \text{nda} \\ [+ex] \end{array} \right] \right] \text{H}$

At this point, I propose that the same rule of Floating H-deletion that we saw in chapter 5 to apply in Margi, also applies in Tiv.

- (106) Floating H-deletion: $\textcircled{\text{H}} \rightarrow \phi / \text{H}$

Floating H-deletion will delete the H suffix of úngwà but will not affect the H suffix of vèndá, giving us the following representations:

$$(107) \quad \text{a.} \quad \left[\left[\begin{array}{c} \text{un} \quad \text{gwa} \\ | \\ \text{H} \end{array} \right] \right] \quad \text{b.} \quad \left[\left[\begin{array}{c} \text{ve} \quad \text{nda} \\ | \\ \text{L} \end{array} \right] \right] \text{H}$$

At the post-lexical stratum, extratonicity will be lost. Since the final vowel of ungwa is toneless, it will receive a L-tone by default, deriving úngwà. As for venda, when extratonicity is lost, the free H-tone of the suffix will link to the final vowel of the stem, deriving vèndá.

Note that the rule assigning extratonicity must crucially be ordered after Raising. Otherwise we would erroneously expect marking of Extratonicity (102) to feed Raising (34) in a case like vèndá.

The rule of Extratonicity will have no appreciable effect on the trisyllabic verb stems. The -H] suffix will link to the second stem vowel by left-to-right linking conventions; the third stem vowel will ultimately receive a L-tone by default, whether or not it has gone through a stage of being marked extratonal.

Concerning the monosyllabic stems, it would not seem unreasonable to assume a convention whereby an entire domain cannot be marked extratonal: ²⁶

$$(108) \quad * \left[\begin{array}{c} \text{X} \\ [+ex] \end{array} \right]_{\text{D}}$$

Given this convention, the derivation of the monosyllabic Imperative forms would proceed exactly as seen above for the monosyllabic Recent Past forms. If the convention in (108) is not adopted, however, a mechanical operation of all the rules discussed for Tiv will in fact derive the correct results in such cases.

To summarize, I propose that the Imperative is marked by a -H] suffix. In addition, a special phonological rule assigning extratonicity to the final vowel of a verb applies in the Imperative. As for the rule of Floating H-deletion, there is no reason not to assume that this is a general rule of Tiv. No ill effects result from such an assumption, and it turns out, in fact, that the rule is required to apply elsewhere.

9.2 Subjunctive

In (109), I give the complete set of forms for the Subjunctive.

(109) Subjunctive

	<u>H-stem</u>		<u>L-stem</u>	
1 syllable:	vè vá	L H	vè dzá	L H
	they are to come		they are to go	
2 syllable:	vè úngwá	L HH	vè vé [!] ndá	L H!H
	they are to hear		they are to refuse	
3 syllable:	vè yévésè	L HHL	vè ngóhórò	L HHL 27
	they are to flee		they are to accept	

As in the Recent Past and the Imperative, the basic marker of the Subjunctive is a -H] suffix. The tonal forms observed on the verb

stems in (109) are exactly as we would expect, given a -H] suffix and a H-tone subject prefix. The problem is that the subject prefixes -- which are normally H -- surface in the Subjunctive with a L-tone. This lowering of the subject prefixes can be accounted for by positing a phonological rule that assigns the marking [+ex] to the subject prefix in the Subjunctive.

(110) Extratonicity (Subjunctive):

$$\sigma \rightarrow [+ex] / \left[\begin{array}{c} \text{SUBJUNCTIVE} \text{ ---} \\ \text{---} \end{array} \right]$$

As an example, consider the derivation of vè vé[!]ndá 'they are to refuse'. On the third cycle, we will have a representation as in (111a).

(111) a.
$$\left[\begin{array}{c} \text{ve} \\ | \\ \text{H} \end{array} \left[\begin{array}{c} \left[\begin{array}{c} \text{venda} \\ | \\ \text{L} \end{array} \right] \text{H} \end{array} \right] \right]$$

H-spread (8) will apply to derive: ²⁸

b.
$$\left[\begin{array}{c} \text{ve} \\ | \\ \text{H} \end{array} \left[\begin{array}{c} \left[\begin{array}{c} \text{venda} \\ | \\ \text{L} \end{array} \right] \text{H} \end{array} \right] \right]$$

When extratonicity is assigned by rule (110), the first syllable will automatically be delinked by the Dissociation Convention (104):

c.
$$\left[\begin{array}{c} \text{ve} \\ [+ex] \\ | \\ \text{H} \end{array} \left[\begin{array}{c} \left[\begin{array}{c} \text{venda} \\ | \\ \text{L} \end{array} \right] \text{H} \end{array} \right] \right]$$

When extratonicity is lost post-lexically, a L-tone will be assigned to the vowel of the subject prefix by default, correctly deriving vè vé'ndá.

As in the extratonicity cases in the Imperative, it is important that the rule of Floating H-deletion applies in the appropriate cases. Consider, for example, vè úngwá 'they are to hear'. After assignment of extratonicity on the third cycle, we will have the following representation:

$$(112) \text{ a. } \left[\begin{array}{c} \text{ve} \\ [+ex] \\ \text{H} \end{array} \left[\left[\begin{array}{c} \text{ungwa} \\ \text{H} \end{array} \right] \text{H} \right] \right]$$

The point to notice about this case is that H-spread is not applicable. So if there was no rule to delete the free H-tone of the prefix, we would expect it to link post-lexically when extratonicity is lost, incorrectly deriving vé úngwá́. The correct result is obtained by deleting the free H-tone (Floating H-deletion) so that the vowel of the prefix will end up being assigned a default L-tone.

Concerning the status of Floating H-deletion, it is interesting to note that the same rule was required in Dschang (chapter 2), Margi (chapter 5) and Tiv. The rule was also implicitly assumed in the analysis of Tonga in chapter 4, although in that case its application was not crucial. It would appear at the very least that this rule is a very common one, and perhaps there is a general convention that

deletes free H-tones when adjacent to linked H-tones. Whatever the answer to this question is, it can only come from the consideration of more languages.

10. Morphological encoding

This thesis began by presenting an outline of a phonological theory that integrates morphological and phonological representations in a fundamental way. And it has been argued throughout this chapter that the predictions of this theory for Tiv are in fact borne out by the facts. In this last section, I will briefly review some of the alternative approaches to encoding morphological information that have been used in previous analyses of Tiv, and I will show that the approach taken in this paper is to be preferred for both conceptual and empirical reasons.

10.1 Boundary symbols

There has been considerable work done in the last several years whose aim has been to eliminate the use of boundary symbols in favour of more direct ways of encoding morphological constituency relations (CF: Rotenberg 1978, Pesetsky 1979, Selkirk 1980, 1982, Mohanan 1982 and Kiparsky 1982). In this section, I will point out a number of conceptual problems resulting from the use of boundary symbols in autosegmental representations. I will also show that the cases requiring such symbols in previous analyses are explained by

the more direct encoding of morphological relations assumed in this thesis.

Consider the theory of boundaries proposed in Goldsmith (1976). Basically, it was suggested that +-boundaries behave differently than #-boundaries in that #-boundaries undergo association while +-boundaries do not:

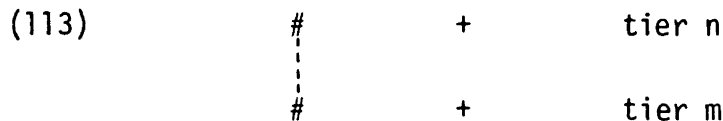

This means that autosegments can be linked across a +-boundary without violating the crossing constraint (45), while they cannot be linked across # boundaries. One could therefore have a representation such as in (114).

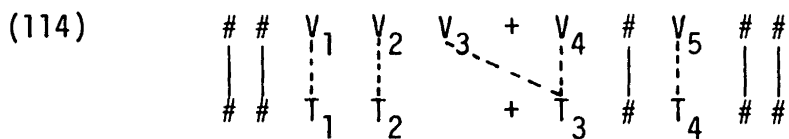

T_3 can link across a +-boundary to V_3 , but T_4 cannot link across a #-boundary to V_4 .²⁹

One of the properties that Tiv displays most vividly is that a morpheme may be: 1) only segmental (for example, the Continuous suffix (10)); 2) only tonal (for example, the Recent Past suffix (section 3.1)); 3) both tonal and segmental (for example, the Future prefix (section 8.1)). If an autosegmental theory uses the notion

of boundary symbols, one predicts the existence of morphemes represented on a single tier, but that include #-boundaries. The General Past morpheme, for example, might be considered just such a morpheme (although it is not by Goldsmith).

(115) General Past: L #

But if the boundary symbol for this tense were to be represented only on the tier where the tonal morpheme itself is represented, then division of a word into domains for tone association would be thrown out of kilter. Take as an example the Past Habitual. In boundary terms, the Past Habitual is marked by the General Past prefix (115), a +H habitual suffix, and a $\begin{matrix} \# \\ \# \end{matrix} \begin{matrix} n \\ L \end{matrix}$ suffix, giving a representation as in (116) for a H-stem verb such as ungwa. (The surface form in this case is !úngwáñ.)

(116) Past Habitual

a. # # ungwa # n # #
 # # L # H + H # L # #

Association of boundaries gives us the representation below:

b. # # ungwa # n # #
 | | / / /
 # # L # H + H # L # #

Without going any further, it is obvious that (116b) is not the desired result. For example, the linking as shown makes it impossible

for the stem tone to link to the stem.

The problem in such a case has been introduced by allowing a morpheme such as the General Past to put a #-boundary on a single tier. What we clearly require is that for every boundary introduced by a morpheme on tier n, there must be a corresponding boundary on tier m. In other words, boundaries do not behave autosegmentally. Boundaries do not link to other boundaries by a left-to-right mapping principle. They do not spread. They do not get deleted on one tier while remaining on another, etcetera.

Essentially, the point is that boundaries have been introduced onto autosegmental tiers not because they exhibit some sort of autosegmental behaviour, but because some device was required to encode morphological constituency. It is preferable, therefore, to encode morphological relations in a direct manner -- such as the manner proposed in lexical phonology -- and to restrict autosegmental tiers to the expression of phonological features.

I will not dwell on the cases for which Goldsmith (1976) actually included #-boundaries in the melodies, namely

- (117) a. Habitual 3: B* H # H
 b. Habitual 4: H # L
 c. Past Habitual: B* H # L

The Habitual 3 and the Past Habitual have already been discussed above (section 3.3), and the Habitual 4 is comparable to the Past

Habitual except that it has the [H- prefix of the 'present' tense (see (10)) instead of the [L- prefix of the 'general past'. (See the appendix for the forms of the Habitual 4) The analysis given in this chapter provides straightforward accounts for these tenses without recourse to boundaries over which linking is impossible.

10.2 Variables

Ever since Arnott's important work on Tiv, researchers have adopted Arnott's suggestion of representing Tiv tenses with a series of tonal melodies. While the details of analyses have varied, the essential intuition has remained that the segmental melody represents the basic lexical entry of a given verb, while the tonal melody represents the tense. So in order to encode a verb's 'lexical' tone into the appropriate melody, variables were introduced. Taking Goldsmith's version of this system as an example, a B variable in a melody means in effect that there are two melodies -- one with a H in the B slot, and one with a L. A B* variable also means that there are two melodies -- one with a !H and the other with a L. H-stem verbs select the melody with a H or a !H in the variable slot, while L-stem verbs select the melody with a L.³⁰ Moreover, nothing requires a tense to have a variable, hence a number of tense melodies consist solely of tones.

This variable approach also predicts cases where a variable might range over different tonal values, for example H and !H.

And it raises a problem as to how to encode on a verb stem the fact that it selects a certain set of values from the tonal variables of the language in question.

Given the variable approach, verbs do not have a unified underlying representation. The same verb may appear with no 'lexical' tone (in the case where there is no variable), with a !H as the 'lexical' tone (when the melody has a B* variable) and with a H as a 'lexical' tone (when the melody contains a B variable). Presumably some tense might even include different melodies in the same tense expression, creating a situation where a verb stem had more than one 'lexical' tone.

Another consequence of such an approach is that 'neutralization' of 'lexical' contrasts -- by the elimination of variables from the tense melody -- is achieved at no cost. In fact, neutralization is to be formally preferred since a variable-less melody is formally simpler than a melody with variables since it generates only a single melody. A melody with a variable generates two melodies -- one with each value of the variable. This is quite a suspect result -- especially because neutralization takes place in only two of the tenses in Tiv discussed in Arnott (1964). Moreover, the two tenses that manifest neutralization are both present tense forms (the 'Present Continuous' and the 'Habitual 4') and the variable approach has no way of accounting for this fact. ³¹

If this approach had resulted in unified tense expressions, it

might have warranted the departure from unified lexical entries for verb stems. But unfortunately, the variable approach to representing tenses has had to resort to the specification of different melodies for stems of differing numbers of syllables. Hence the approach is one where variables allow different expressions of 'lexical' tones (that is, B, B* or no variable for the same stem) and then different variables may even be used in the expression of the same tense, depending on the shape of the stem. For example, the Habitual 1 tense assigns a B* H melody for monosyllabic and disyllabic stems and a B H L melody for trisyllabic stems.

In contrast, the approach taken in this paper has not required the notion of tonal variable at all. Uniform underlying representations of verb stems have been proposed:

- (118) a. H-stem verbs:
$$\begin{bmatrix} \sigma & (\sigma) & (\sigma) \\ H & & \end{bmatrix}$$
- b. L-stem verbs:
$$\begin{bmatrix} \sigma & (\sigma) & (\sigma) \\ L & & \end{bmatrix}$$

The expressions of tenses are uniform in that they do not depend on the number of syllables in a verb base. These results constitute strong evidence for the lexical approach to Tiv argued for in this chapter, as opposed to the melody approach assumed by many earlier researchers.

APPENDIX

Eight of the eleven Tiv tenses discussed in Arnott (1964) have been examined above. In this appendix, I will give the forms for the three remaining tenses.

Habitual 2

	<u>H-stem</u>	<u>L-stem</u>
1 syllable:	mbá' vé' !H! they come	mbá' dzé' !H! they go
2 syllable:	mbá' óngó' !HH! they hear	mbá' vèndé' LH! they refuse
3 syllable:	???	???

This tense is marked by the -H] suffix that is present in all five habitual tenses. In addition there is a -L] suffix, and ablaut applies to the stems. Finally, the 'present' tense is marked by the 'General Past' [L- prefix. (See below the discussion of the Habitual 4.)

Arnott notes that there does not seem to be any Habitual 2 form for L-stem trisyllabic verbs. And the form he gives for the H-stem trisyllabic case is identical to the Habitual 3 form. I propose therefore that there are no forms for trisyllabic stems in this tense. While I have no explanation for this gap, it is noteworthy that this is a tense that requires ablaut, and in general ablaut does not apply to trisyllabic stems. Hence the failure of ablaut to apply and the absence of Habitual 2 forms seem to correlate.

Habitual 4

	<u>H-stem</u>		<u>L-stem</u>	
1 syllable:	ká [!] vé váân HHL they come		ká [!] vé dzáân HHL they go	
2 syllable:	ká [!] vé úngwân HHL they hear		ká [!] vé véndân HHL they refuse	
3 syllable:	ká [!] vé yévéсэн hHHL they flee		ká [!] vé ngóhôr HHL they accept	

As with all other habitual tenses, the Habitual 4 has a -n] suffix. Like the Habitual 3 and the Past Habitual, it has a L-tone -n] suffix that has a L-tone -Vn] allomorph after monosyllabic stems. The -n] suffix appears to be optional for trisyllabic verb stems in the three tenses in which it occurs. Arnott implies that it is obligatory in the Past Habitual, but Abraham seems to give cases where the L-tone -n] suffix is not present with trisyllabic verbs. Further research is required in this area. 'Present' tense is marked in the Habitual 4 by the present tense prefix [H- that also occurs in the (?present) Continuous.

Habituals (summarized)

Since five 'habitual' tenses have been described in this chapter, it may be useful to give a brief summary at this point. There are four suffixes that occur in the various habitual tenses. In Table 1, I indicate which of these suffixes are selected for each tense.

TABLE 1

<u>Habitual suffixes:</u>	-H]	- ⁿ]	-H]	-L]
Habitual 1 (40):	X	-	-	-
Habitual 4 (Appendix):	X	X	-	-
Past Habitual (41):	X	X	-	-
Habitual 3 (39):	X	X	X	-
Habitual 2 (Appendix):	X	-	-	X

As for tense prefixes, all but the Habitual 4 take the [L- prefix that up until now I have been calling the 'General Past' prefix. It is not really surprising that 'present' habitual forms should use a 'past' tense marker. Abraham (1940b) observes that in some cases, verbs in the 'General Past' are interpreted with a 'present' tense meaning, and in other cases are interpreted as 'past'. Probably the [L- morpheme would be better labeled as 'non-future'.

The actual tense interpretation seems to depend therefore on the prefix - suffix combination that makes up the form. The 'non-future' prefix will indicate 'present' habitual or 'past' habitual depending on the specific habitual morphemes. Note that the Habitual 4 is special in that it takes the unambiguously 'present' [H- prefix. And the Habitual 2 is distinct in that ablaut applies.

As a final point, there are what appear to be typographical

errors in certain examples of habitual forms in Table I of Arnott (1964). For example, in the Habitual 3 example álóm váán 'Hare is coming', there is no downstep between the subject noun phrase and the verb. But in Table III and Table IV, as well as in the text, Arnott specifically describes a downstep in such forms. I assume therefore that the correct form is actually álóm[!] váán[!]. In this and other cases where there is a discrepancy between what appears in Table III and Table IV, as opposed to Table I, the forms that I have given in this chapter are those of Table III and Table IV.

(Present) Continuous

	<u>H-stem</u>		<u>L-stem</u>	
1 syllable:	mbá [!] vâñ HL		mbá [!] dzâñ HL	
	they are coming		they are going	
2 syllable:	mbá [!] úngwàñ HLL		mbá [!] véndàñ HLL	
	they are hearing		they are refusing	
3 syllable:	mbá [!] yévèsè HLL		mbá [!] ngóhòr HLL	
	they are fleeing		they are accepting	

This tense, which is called 'Continuous' by Arnott and 'Present' by Abraham, is marked by a present tense [H- prefix and a continuous aspect -n] suffix. In fact, we saw one derivation of a Continuous tense form in section 1.1 above. Note that the -n] suffix is not added to trisyllabic stems. As noted in footnote 31, the neutralization that takes place in this tense between L-stem and H-stem verbs is the result of the effect of H-spread (8) on stems with an initial L-tone.

FOOTNOTES: CHAPTER 6

1. For discussion and formulation of the rule creating contour tones in examples such as (3-5), see section 4.1 below.
2. Hoffmann (1976) showed that there is a H suffix present in those classes which take a H-tone prefix. This H-tone suffix is purely tonal in some noun classes, while in other classes, it is both segmental and tonal. For relevant forms, see Abraham (1940b).
3. This form undergoes a late rule of vowel deletion, deriving ngòhòr. See section 4.1.
4. Thanks to K.P. Mohanan for pointing this out to me.
5. See chapter 1, section 2.1.
6. Note, moreover, that even an analysis that interpreted a $\begin{array}{c} V \\ \swarrow \searrow \\ L \quad H \end{array}$ sequence phonetically as !H would require complications: 1) The lowering effect of a L on a H in Tiv is independent of whether the L is linked or free. 2) There are $\begin{array}{c} V \\ \swarrow \searrow \\ L \quad H \end{array}$ sequences in Tiv that are phonetically interpreted as rising tones. See section 4.1.
7. The forms given in (31) indicate the Recent Past forms after a subject prefix that ends in a L-tone, that is, a subject prefix with the pattern L or HL. Such prefixes are found in the Class 1 indefinite and Class 3 (the L tone pattern) and in Class 1, 1st and 2nd persons (the HL pattern). All other classes (eleven in all) have H prefixes. Where the subject prefix is H, H-spread will be triggered in the L-stem disyllabic and trisyllabic cases where the first stem

vowel is L. The resulting forms will be discussed in section 8.2. This analysis of noun class subject prefixes is essentially that of Carl Hoffmann. Arnott (1964) observed the relevant distinctions but assigned the '!' of the HL prefixes (eg. m' yévése 'I fled') to the tense melody.

The reason that the HL Class 1 prefixes do not trigger downstep in tenses other than the Recent Past is a phonological one. In the other tenses where these same prefixes occur, there is a L-tone prefix anyway -- so the [HL] [L] pattern becomes indistinguishable from the [H] [L] pattern of the H-tone prefixes.

8. After vowel deletion, this form will become ngòhôr.
9. For discussion of ablaut in Tiv, see Archangeli and Pulleyblank (in preparation).
10. One could not assume a lexical pattern HL for stems such as yevese to solve this problem, since that would predict the pattern * yévèsé instead of yévése in the Recent Past.
11. For an explanation of the loss of the initial downstep in this form, see section 8.2.
12. After vowel deletion, this form will become ngòhôr.
13. For a discussion of the Elsewhere Condition, see, for example, Kiparsky (1973, 1982).
14. See Archangeli and Pulleyblank (in preparation).
15. I assume that m, n, l, r, v and gh are all [+son]; whatever the feature specification, however, the point is the same.

16. The segments transcribed 'NC...' in this chapter are prenasalized, and the segments transcribed 'Cy...' or 'Cw...' are palatalized and labialized respectively.

17. Note that such a constraint would prevent application of the Association Conventions unless some lexical entries included tones linked to tone-bearing units. Interestingly, such is the case in the languages examined in this thesis. For example, in Tiv, the Future tense prefix requires pre-association:

$$\left[\begin{array}{c} a \\ | \\ L \ H \ L \end{array} \right]$$

In Dschang, the word for child requires pre-association:

$$\left[\begin{array}{c} m\text{ɔ} \\ | \\ L \ H \end{array} \right]$$

Similarly, Yoruba, Yala, Luganda and Tonga have all been seen to require varying amounts of pre-association. And it can also be demonstrated that pre-linking is necessary in Margi for certain morphemes.

18. See Archangeli and Pulleyblank (in preparation).

19. Application of default rules will be delayed by the existence of language-specific rules with which the default rule are in an Elsewhere relationship. See section 7. This is not relevant in this

case, however, since H-spread is not in an Elsewhere relationship with Default L-insertion.

20. It is interesting to note the different ways of reacting to violations of syllable structure and to violations of tone linking. Following McCarthy (1979), it is generally assumed that if a rule would violate a constraint on syllable structure, then the rule is blocked from applying. On the other hand, following Goldsmith (1976), it is generally assumed in tone that if a rule creates a prohibited tonal linking, this does not block the rule -- the output is fixed up. The difference in conventions seems conceptually undesirable. One might propose, for example, that if a rule would violate either a tonal constraint or a syllable structure constraint, then it would be blocked from applying. In tone, this would mean that the one-to-one constraint would become largely a constraint on rules. For example, H-spread as formulated for Tiv in (8) would be an impossible lexical rule since it creates contour tones. Delinking would have to be indicated in the structural change in order for H-spread to be a permissible lexical rule. This whole issue will be left for further study.

21. H-spread could not apply in a case like this because it will not spread a H onto a L that is linked to the final tone-bearing unit of the word. Consider, for example, the Past Habitual form of ungwa 'to hear':

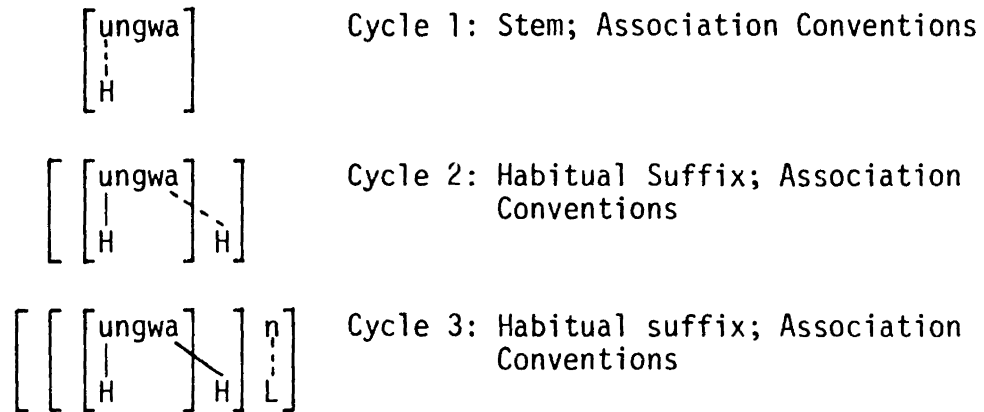

After prefixation of the General Past prefix and a subject prefix, we obtain the form vé [!]úngwân 'they used to hear'. The crucial aspect of the above derivation is that H-spread does not apply on the third cycle to displace the L of habitual suffix. If it did, we would incorrectly predict a falling pattern on the -n] pre-pausally and a H! pattern non-pre-pausally. For reasons such as this, H-spread must be restricted to applying to a L linked to a non-final vowel.

22. This possibility was suggested to me by Paul Kiparsky.

23 After V-deletion and T-attachment, this form will surface as !á ngòhòr.

24. After V-deletion and T-attachment, this form will surface as ngòhòr.

25. This convention was suggested to me by Morris Halle.

26. Note that this would not affect cases like Margi where morphemes are underlyingly marked [+ex]. Such morphemes are not scanned by the phonology until after having been added to something else, at which point the entire relevant domain is not [+ex].

27. After V-deletion and T-attachment, this form will surface as vè ngóhôr.

28. There is no crucial reason to order H-spread (8) before Extratonicity (Subjunctive) (110). The other order would produce the same results.

29. Note how similar this proposal is in spirit to the convention in Chomsky and Halle (1968) that allows rules to apply across +-boundaries automatically but only across #-boundaries if stipulated by rule. This similarity was pointed out to me by K.P. Mohanan.

30. Note that by allowing a variable to encode !H, one is weakening the theory of downstep by treating a downstepped H as though it constituted a single unit, instead of treating it as a LH sequence.

31. This fact is accounted for in the approach of this chapter because the marker of the 'present' tense is a [H- prefix that occurs in both the Present Continuous and the Habitual 4. This [H- prefix triggers H-spread (8), thereby replacing the initial L of a L-stem verb with a H.

REFERENCES

- Abraham, R.C. (1940) a. A Dictionary of the Tiv Language. Gregg International Publishers Ltd.
- (1940) b. The Principles of Tiv. Gregg International Publishers Ltd.
- (1940) c. A Tiv Reader for European Students. Gregg International Publishers Ltd.
- (1958) Dictionary of Modern Yoruba. London: Hodder and Stoughton.
- Akinlabi, A. (1982) "The Phonological Nature of Yoruba Tone", paper presented at the Third Annual Conference of the Linguistic Association of Nigeria.
- (in preparation) Yoruba Tonal Phonology. Ph.D dissertation, University of Ibadan.
- Allen, M. (1978) Morphological Investigations. Ph.D dissertation, University of Connecticut.
- Anderson, S.C. (1980) "An Autosegmental Account of Bamileke-Dschang Tonology", Journal of Linguistic Research 1:4, 74-94.
- Anderson, S.R. (1974) The Organization of Phonology. Academic Press.
- (1978) "Tone Features", in V. Fromkin (ed.) Tone: A Linguistic Survey. Academic Press.
- Archangeli, D. (in preparation) "Yokuts Vowels and Underspecification".
- and D. Pulleyblank (in preparation) "Underspecification".
- Armstrong, L.F. (1940) The Phonetic and Tonal Structure of Kikuyu. London: Oxford University Press.
- Armstrong, R.G. (1968) "Yala (Ikom): A terraced-level language with three tones", The Journal of West African Languages 5:1, 49-58.
- Arnott, D.W. (1964) "Downstep in the Tiv Verbal System", African Language Studies 5, 34-51, BSOAS.
- (1968) "Introduction" to Abraham, R.C. (1940) b. The Principles of Tiv. Gregg International Publishers Ltd.

Aronoff, M. (1976) Word Formation in Generative Grammar. Cambridge, Mass.: MIT Press.

Awobuluyi, O. (1975) "On 'the Subject Concord Prefix' in Yoruba", Studies in African Linguistics 6:3.

----- (1977) Essentials of Yoruba Grammar. Ibadan: Oxford University Press Nigeria.

----- (1982) "Vowel Assimilation in Yoruba", paper presented at the Fifteenth African Language Conference, Port Harcourt.

Badejo, B.R. (1979) L'Elision des Voyelles Orales du Yoruba. Master's thesis, University of Montreal.

Bamgbose, A. (1965) "Assimilation and Contraction in Yoruba", Journal of West African Languages 1:1, 21-27.

----- (1965) A Grammar of Yoruba. Cambridge, Eng.: Cambridge University Press.

----- (1966) "The Assimilated Low Tone in Yoruba", Lingua, 1-13.

----- (1980) "Pronouns, Concord and Pronominalization", Afrika und Ubersee, Band LXIII, 189-198.

Barlow, A.R. (1951) Studies in Kikuyu Grammar and Idiom. Edinburgh: William Blackwood & Sons, Ltd.

Bloomfield, L. (1933) Language. London: George Allen & Unwin, Ltd.

Borer, H. (1981) Parametric Variation in Clitic Constructions. Ph.D dissertation, MIT.

Chomsky, N. (1957) Syntactic Structures. The Hague: Mouton.

----- (1970) "Remarks on Nominalization", in R.A. Jacobs and P.S. Rosenbaum (eds.) Readings in English Transformational Grammar. Waltham, Mass.: Ginn & Co.

----- (1982) Lectures on Government and Binding: The Pisa Lectures. Dordrecht: Foris.

----- and M. Halle (1968) The Sound Pattern of English. New York: Harper and Row.

Clark, M. (1982) "An Accentual Analysis of the Igbo Verb", paper presented at the Thirteenth Annual Conference on African Linguistics, Montreal.

Clements, G.N. (1981) "The Hierarchical Representation of Tone", in G.N. Clements (ed.) Harvard Studies in Phonology, Vol. II, 50-108.

----- and K. Ford (1979) "Kikuyu Tone Shift and its Synchronic Consequences", Linguistic Inquiry 10:2, 179-210.

----- (1981) "On the Phonological Status of Downstep in Kikuyu", in D. Goyvaerts (ed.) Phonology in the 1980's. Gent.

----- and J. Goldsmith (1983) "Introduction" to G.N. Clements and J. Goldsmith (eds.) Autosegmental Studies in Bantu Tone. Dordrecht: Foris.

Courtenay, K. (1969) A Generative Phonology of Yoruba. Ph.D dissertation, UCLA.

Courtenay, K. (1971) "Yoruba: a 'Terraced-level' Language with Three Tonemes", Studies in African Linguistics 2, 239-56.

Dresher, B.E. (1983) "Postlexical Phonology in Tiberian Hebrew", paper presented at WCCFL II, USC.

Dwyer, D. (1978) "What sort of tone language is Mende?", Studies in African Linguistics 9:2, 167-208.

Fresco, E.M. (1970) "Topics in Yoruba Dialect Phonology", Studies in African Linguistics, supplement to Volume 1.

Fromkin, V. (ed.) (1978) Tone: A Linguistic Survey. Academic Press.

Goldsmith, J. (1976) Autosegmental Phonology. Indiana University Linguistics Club. [Published by Garland Press, 1979]

----- (1981) "Towards an Autosegmental Theory of Accent: The Case of Tonga", Indiana University Linguistics Club.

----- (1982) "Accent Systems", ms. Indiana University.

Halle, M. (1973) "Prolegomena to a Theory of Word Formation", Linguistic Inquiry 4:1, 3-16.

----- (1978) "Formal vs. Functional Considerations in Phonology", Indiana University Linguistics Club.

----- and P. Kiparsky (1982) "Tone Languages and Pitch Accent Languages", paper presented at IRCAM.

----- and K.P. Mohanan (in preparation) "Issues in the Segmental Phonology of Modern English".

----- and J.R. Vergnaud (1982) "On the Framework of Autosegmental Phonology", in H. van der Hulst and N. Smith (eds.) The Structure of Phonological Representations (Part I). Dordrecht: Foris.

Harris, J. (1983) Syllable Structure and Stress in Spanish: A Nonlinear Analysis. Cambridge, Mass.: MIT Press.

Hayes, B. (1980) A Metrical Theory of Stress Rules. Ph.D dissertation, MIT. [Revised version distributed by Indiana University Linguistics Club, 1981]

----- (1982) "Extrametricity and English Stress", Linguistic Inquiry 13:2, 227-276.

Hoffmann, C. (1963) A Grammar of the Margi Language. London: Oxford University Press.

----- (1973) "The vowel system of the Okpe monosyllabic verb", Research Notes 6 (nos. 1-3), 79-112. Department of Linguistics, University of Ibadan.

----- (1976) lecture notes, University of Ibadan.

Hombert, J.M. (1974) "Universals of Downdrift: Their Phonetic Basis and Significance for a Theory of Tone", Studies in African Linguistics Supplement 5, 169-183.

Huang, C.T.J. (1980) "The Metrical Structure of Terraced-level Tones", in the proceedings of NELS 10, 257-270.

Hyman, L. (ed.) (1976) Studies in Bantu Tonology. Southern California Occasional Papers in Linguistics, no. 3.

----- (1978) "Tone and/or accent", in D.J. Napoli (ed.) Elements of Tone, Stress and Intonation. Washington: Georgetown University Press.

----- (1982) a. "Globality and the Accentual Analysis of Luganda Tone", ms. USC.

----- (1982) b. "Against Asterisks in Luganda and Bantu Tonology: a reply to Hyman (1982a)", ms. USC.

----- (1982) c. "Dschang Tonology", paper presented at the University of Texas.

- and P. Schuh (1974) "Universals of Tone Rules: Evidence from West Africa", Linguistic Inquiry 5:1, 81-115.
- and M. Tadadjeu (1976) "Floating Tones in Mbam-Nkam", in L. Hyman (ed.) Studies in Bantu Tonology. Southern California Occasional Papers in Linguistics, no. 3.
- and N. Valinande (to appear) "Globality in the Kinande Tone System", in D. Goyvaerts (ed.) Studies in African Linguistics.
- Jackendoff, R. (1977) X̄ Syntax: A study of phrase structure. Cambridge, Mass.: MIT Press.
- Jaeggli, O. (1980) On Some Phonologically-Null Elements in Syntax. Ph.D dissertation, MIT.
- Kaye, J. and H. Koopman (1982) "Les tons du système verbal en bété (gbadi)", paper presented at the Thirteenth Annual Conference on African Linguistics, Montreal.
- and J. Lowenstamm (1981) "De la syllabicité", ms. UQAM.
- Keyser, S.J. and P. Kiparsky (1982) "Finnish Syllable Structure", ms. MIT.
- Kiparsky, P. (1973) "Elsewhere in Phonology", in S.R. Anderson and P. Kiparsky (eds.) A Festschrift for Morris Halle. New York: Holt, Rinehart and Winston.
- (1974) "Phonological Representations", in O. Fujimura (ed.) Three Dimensions of Linguistic Theory. Paishukan, Tokyo.
- (1982) "Lexical Morphology and Phonology", in The Linguistic Society of Korea (ed.) Linguistics in the Morning Calm. Seoul: Hanshin Publishing Co.
- (1982) "The Vedic and Pāṇinian Accent Systems", in P. Kiparsky Some Theoretical Problems in Pāṇini's Grammar. Poona: Bhandarkar Oriental Research Institute.
- (1983) "Word-level rules in Icelandic", paper presented at Stanford Workshop on Lexical Phonology and Morphology.
- (in preparation) "The Lexical Phonology of Vedic Accent", ms. MIT
- Koopman, H. and D. Sportiche (1982) "Le ton abstrait du Kagwe", in J. Kaye, H. Koopman and D. Sportiche (eds.) Projet sur les langues Kru. UQAM.

Laughren, M. (1983) "Tone in Zulu Nouns", in G.N. Clements and J. Goldsmith (eds.) Autosegmental Studies in Bantu Tone. Dordrecht: Foris.

La Velle, C.R. (1974) "An experimental study of Yoruba tone", Studies in African Linguistics, Supplement 5, 185-194.

Leben, W. (1973) Suprasegmental Phonology. Indiana University Linguistics Club.

Lees, R.B. (1960) The Grammar of English Nominalizations. The Hague: Mouton & Co.

Levin, J. (1983) "Reduplication and Prosodic Structure", paper presented at GLOW.

Lieberman, M. (1983) "Phonetic representations", paper presented at Stanford Workshop on Lexical Phonology and Morphology.

----- and J. Pierrehumbert (1982) "Intonational Invariance under Changes in Pitch Range and Length", ms. Bell Labs.

Lightner, T.M. (1963) "A Note on the Formulation of Phonological Rules", Quarterly Progress Report of the Research Laboratory of Electronics, MIT no. 68, 187-189

Martinet, A. (1965) "De la morphonologie", La Linguistique no. 1, 16-31.

Mascaro, J. (1976) Catalan Phonology and the Phonological Cycle. Indiana University Linguistics Club.

May, J. and E. Loeweke (1964) "The phonological hierarchy in Fasu", Anthropological Linguistics 7.5, 89-97.

McCarthy, J. (1979) Formal Problems in Semitic Phonology and Morphology. Ph.D dissertation, MIT.

McCawley, J. (1970) "A Note on Tiv Conjugation", Studies in African Linguistics 1:2, 123-129.

Meeussen, A.E. (1963) "Morphotonology of the Tonga Verb", Journal of African Linguistics Vol.2, Part I.

Mohanan, K.P. (1982) Lexical Phonology. Indiana University Linguistics Club.

----- and T. Mohanan (1983) "Lexical Phonology of the Consonant System in Malayalam", ms. MIT.

Myers, A. (1974) "Phonology of Kikuyu", ms. MIT.

Nicole, J. (1980) "Downstepped Low Tone in Nawdm", Journal of African Languages and Linguistics 2: 133-139.

Odden, D. (1982) "An Accentual Approach to Tone in Kimatuumbi", paper presented at the Thirteenth Annual Conference on African Linguistics, Montreal.

----- (1983) "A metrical theory of tone register", paper given at Harvard University.

Oyelaran, O. (1971) Yoruba Phonology. Ph.D dissertation, Stanford University.

Pesetsky, D. (1979) "Russian Morphology and Lexical Theory", ms. MIT.

Pierrehumbert, J. (1980) The Phonology and Phonetics of English Intonation. Ph.D dissertation, MIT. [Forthcoming from MIT Press]

Poser, W. (1980) "On Some Topics in Non-linear Phonology", ms. MIT.

Pulleyblank, D. (to appear) "Accent in Kimatuumbi", in J. Kaye (ed.) Current Approaches to African Linguistics, Vol. II. Dordrecht: Foris.

Rivas, A. (1977) A Theory of Clitics. Ph.D dissertation, MIT.

Rotenberg, J. (1978) The Syntax of Phonology. Ph.D dissertation, MIT.

Rubach, J. (1981) Cyclic Phonology and Palatalization in Polish and English. Warsaw: Wydawnictwa Uniwersytetu Warszawskiego.

Sapir, E. (1921) Language. New York: Harcourt, Brace & World, Inc.

Schachter, P. (1969) "Natural assimilation rules in Akan", International Journal of American Linguistics 35:4, 342-355.

Selkirk, E. (1980) "Prosodic Domains in Phonology: Sanskrit Revisited", in M. Aronoff and M.L. Kean (eds.) Juncture. Anna Libri, Sarasota, California.

----- (1982) The Syntax of Words. Cambridge, Mass.; MIT Press.

Siegel, D. (1974) Topics in English Morphology. Ph.D dissertation, MIT.

----- (1977) "The Adjacency Condition and the Theory of Morphology", in Proceedings of the Eighth Annual Meeting of the North East Linguistic Society, Amherst, Mass.

Simpson, J. (1983) "Interaction of morphology and syntax in Warlpiri", paper presented at WCCFL II, USC.

Stahlke, H. (1974) "The Development of the Three-Way Tonal Contrast in Yoruba", in E. Voeltz (ed.) Third Annual Conference on African Linguistics. Indiana University, Bloomington.

Stanley, R. (1967) "Redundancy Rules in Phonology", Language 43:1.

Steriade, D. (1982) Greek Prosodies and the Nature of Syllabification. Ph.D dissertation, MIT.

Stevick, E.W. (1969) "Tone in Bantu", International Journal of American Linguistics, 35:4, 330-341.

Stewart, J.M. (1965) "The Typology of the Twi Tone System", Bulletin of the Institute of African Studies, University of Ghana, Legon, no. 1, 1-27.

----- (1981) "Key Lowering (Downstep/Downglide) in Dschang", Journal of African Languages and Linguistics 3:2, 113-138.

Tadadjeu, M. (1974) "Floating Tones, Shifting Rules, and Downstep in Dschang-Bamileke", Studies in African Linguistics, Supplement 5, 283-290.

----- (1977) "Le Dschang".

Trubetzkoy, N.S. (1929) "Sur la 'morphoclogie'", Travaux du Cercle Linguistique de Prague, Vol. 1. 85-88. [Reproduced in J. Vachek (ed.) (1964) A Prague School Reader in Linguistics. Indiana University Press.

Ward, I.C. (1952) An Introduction to the Yoruba Language. Cambridge: W. Heffer & Sons Ltd.

Welmers, W.E. (1959) "Tonemics, morphotonemics, and tonal morphemes", General Linguistics 4, 1-9.

----- (1973) African Language Structures. Berkeley & Los Angeles: University of California Press.

Whitney, W.D. (1879) A Sanskrit Grammar. Leipzig: Breitkopf and Hartel.

Williams, E.S. (1971) "Underlying Tone in Margi and Igbo", published in Linguistic Inquiry (1976), Vol.7, no.3.

Winston, F.D.D. (1960) "The 'mid tone' in Efik", African Language Studies, 1, 185-92.

Wright, M.S. (1983) A Metrical Approach to Tone Sandhi in Chinese Dialects. Ph.D dissertation, University of Massachusetts, Amherst.

Yip, M. (1980) The Tonal Phonology of Chinese. Ph.D dissertation, MIT.